

Efficiency Improvements Of A Thermal Power Plant By Making Use Of The Waste Heat Of Large Datacenters Using Two-Phase On-Chip Cooling.

N. Lamaison¹, J. Marcinichen¹, J. Thome¹

¹Laboratory of Heat and Mass Transfer (LTCM), École Polytechnique Fédérale de Lausanne (EPFL), Lausanne, Switzerland.

Abstract: Cooling of datacenters is estimated to have an annual electricity cost of 1.4 billion dollars in the United States and 3.6 billion dollars worldwide. Currently, refrigerated air is the most widely used means of cooling datacenter's servers. Modern datacenters require a heat dissipation rate in the order of 5 to 15 MW and current air cooling technology represents around 45% of the total energy consumed. Based on the above issues, thermal designers of datacenters and server manufacturers now seem to agree that there is an immediate need to improve the server cooling process. On-chip cooling research is being developed in this context to propose a new, more efficient cooling technology. This also allows the recovery of the heat rejected by the servers in a proper way, making it possible to reuse elsewhere, in another application. The present investigation develops a case study considering two different cooling systems applied on a datacenter and exploring the application of energy recovered in the condenser on a feedwater heater of a coal power plant. The effects of the evaporating and condensing temperatures on the cooling cycle performance and the potential to recover energy, and consequently the effect on the power plant efficiency, are evaluated. The analyses consider the main objective function to be the minimization of energy consumption, the corresponding CO₂ footprint and operating costs. From the datacenter's point of view, when compared with traditional air-cooling systems, energy consumption, without considering energy recovery, can be reduced by as much as 45 % when using a liquid pumping cycle and 35 % when using a vapour compression cycle. From the power plant point of view, the results showed that, when the pressure of the feedwater heater is optimized, an increase of up to 6.5 % of the overall power plant efficiency can be obtained when using a vapour compression cycle to cool the datacenter. Considering the vapour compression cycle and a datacenter of 100000 blades, overall savings (considering the power plant and the datacenter as a whole system) of 2170 tons of CO₂ and \$0.34 million per MW of electricity production were obtained. Additional investigation was developed considering the effects of partial operation of the datacenter and/or the power utility on the parameters mentioned beforehand. For such an investigation the start-up was the ideal match between a datacenter of 100000 blades and a power plant, both with 100 % of operational uptime. It has been shown that some cases could lead to impossible thermodynamic operations, meaning that special attention must be given when the design of such integrated utilities (datacenter and power plant) is made.

Keywords: Datacenter, Power Plant, Energy Recovery, Vapour Compression And Liquid Pumping Cooling Cycles, Microevaporator, Two-Phase Flow.

1. Introduction

Reduction of electrical energy consumption is imperative to mitigate global warming caused by fossil fuel consumption. To achieve this objective, technologies requiring less electricity need to be developed (while still increasing performance) and the waste heat should be recovered. Notably, the cleanest energy is that which was never wastefully consumed. In particular, under current efficiency trends, the energy usage of datacenters in the US is estimated to reach 100 billion kWh by 2011, which represents an annual cost of approximately \$7.4 billion [1]. It is projected that with the current growth and energy consumption rate of datacenters, while also taking into account that the energy production increases by 1% each year, datacenters will consume all the available electrical energy in the US by 2050 [2]. Amazingly, this crisis in the making is so far not even on the "radar screen" of policy makers or the media.

Cooling of datacenters can represent up to 45% [3] of this total consumption using current cooling technologies (air cooling). This means an estimated 45 billion kWh usage by 2011 in the US, with an annual cost of \$3.3 billion, just for cooling. Moreover, the limitations of air cooling are currently being approached due to the performance increase in microprocessors. These new microprocessors will effectively have heat fluxes in the order of 100 W/cm^2 and Saini and Webb [4] proved that the maximum heat removal capacity of air cooling technology is 37 W/cm^2 . Hence, these issues highlight the need for alternative solutions to air cooling.

One solution is to make use of on-chip cooling. Recent publications show the development of primarily four competing technologies for the cooling of chips [5]: microchannel single-phase flow, porous media flow, jet impingement cooling and microchannel two-phase flow. Leonard and Philips [6] showed that the use of such new technologies for cooling of chips could produce savings in energy consumption of over 60%. Agostini *et al.*[5] emphasised that the most promising of the four technologies was microchannel two-phase cooling. Advantages of two-phase cooling over other cooling technologies have been addressed by Marcinichen *et al.*[7], such as the use of the latent heat instead of the sensible heat, the better uniformity of the chip temperature, the low pressure drop and pumping power and the higher attainable heat fluxes (300 W/cm^2 , [8])

In comparison with air cooling, one important advantage of on-chip cooling is that the heat gained from cooling the chips can be easily reused elsewhere. The heat removal process is local to the server in on-chip cooling, thus minimizing any losses to the environment and making it possible to reuse the datacenter's waste heat in a secondary application. A problem with recovering the heat of the datacenter is not in the quantity but rather in the quality of heat available. Currently, heat is being ejected into the atmosphere at temperatures of about 40°C when using traditional air cooling methods. Due to the effective cooling of chips when using on-chip cooling, fluid approach temperatures of about 60°C can be realized, while removing high heat fluxes and keeping chip temperatures below 85°C [9].

Although the exergy is much greater than when cooling the chips at room temperature, its use is still very limited since the recovered heat would be mostly suitable for district heating. This, of course, is also seasonal, implying that the heat would need to be used elsewhere or dumped in the atmosphere half of the year. This is where the advantages of a two phase system becomes clearer, as the system could be used in the form of a vapour compression cycle, with condenser temperatures of 90°C being feasible. The potential of reusing this energy is thus much greater. One potential market for selling this recovered heat is to the companies, i.e. the power utilities, who generate it in the first place.

The present study aims mainly to demonstrate the potential of two-phase on-chip cooling of datacenters regarding energy recovery through a power plant. Two different cooling cycles are investigated; one using a liquid pump as the fluid driver (LP cycle, maximum condensing temperature of 60°C) and the other using a compressor (VC cycle, condensing temperature up to 100°C). A coal fired thermal power plant was selected to be analysed, since more than 80% of the world's energy is produced from this type of utility. The work of Cullen [10], which affirms that a coal-fired power plant is the conversion device that would deliver the most savings in the upstream fuel conversion and electricity generation processes if efficiency is increased by 1%, helps to support such a selection to be evaluated.

This study is a continuation of the previous investigation developed by Olivier *et al.*[11], which evaluated the same cooling cycles and observed the influence of the condensing temperature on the performances of datacenters and power plants. The CO₂ footprint and monetary savings were also evaluated when integrating the cooling cycle of the datacenter with the boiler feedwater heater of the coal fired power plant. Thus, the purpose here is to continue with such an analysis by also evaluating the effects of the evaporating temperature as well as the datacenter and power plant's partial operation on the thermodynamic, environment and economic parameters mentioned beforehand.

2. Case study

2.1. Overall presentation

The case study is performed with a datacenter that uses on-chip cooling to cool the blade servers. The removed heat is then redistributed to a power plant to increase its efficiency. The power utility is a thermal regenerative Rankine cycle consisting of a boiler, a high and low pressure turbine, a condenser, a low pressure and high pressure feedwater pump and a feedwater heater. The feedwater heater receives heat from steam tapped after the high pressure turbine. The optimal pressure for tapping the steam will be calculated to obtain maximum thermal efficiency in each simulation. The datacenter waste heat will be injected into the Rankine cycle after the condenser and prior to the feedwater heater through a main heat exchanger (MHE). The effectiveness of this heat exchanger (ϵ) will be defined later.

The cooling cycles have been completely described by Marcinichen *et al.*[12]. In summary, the simulated LP cycle is composed of a pump, which drives the refrigerant through the blade. The flow then passes through the MHE where heat is removed. Finally, a subcooler to prevent cavitation in the pump (guarantees subcooling at the pump inlet) is used, as can be seen in Figure 1 (red line cycle). The flow in the simulated VC cycle (green line cycle) is driven by a variable speed compressor (VSC). After the VSC, the flow passes through three heat exchangers, the MHE, an internal heat exchanger (iHEX) and the low pressure receiver (LPR). The idea is to guarantee subcooling and superheating respectively at the inlet of the blades and VSC. This is also an indirect way to increase the overall performance of the cycle since the thermodynamic conditions are well defined. The expansion is insured thanks to an electric expansion valve (EEV) before the flow goes through the blade. In this cycle, the condensing temperature is much higher than the evaporating temperature due to the compression, which is not the case for the LP cycle where evaporation and condensation temperatures were here considered the same due to the low pressure drop in such a system. In both cycles, the cooling of the IT (information technology) equipment is taking place in what was defined as blades. These blades are separated into two heat load parts. The first is the heat load associated with the chips, where the microevaporator is installed, and the second is the heat load of the additional electronic components presented in such blades (memories, converters, hard drives etc.), which will be cooled by heat spreaders (HS). The two cycles and the power plant can be seen schematically in Figure 1.

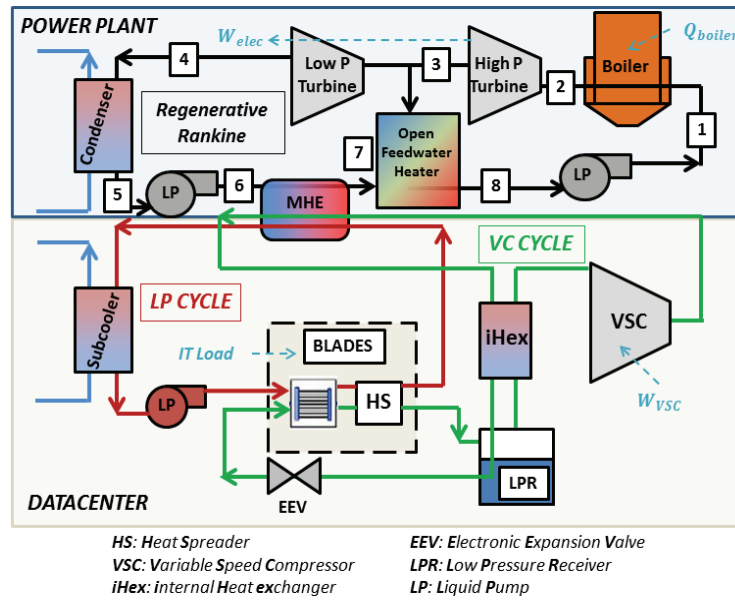

Figure 1: Coupling of the datacenter with a coal fired power plant

For the simulations, the working pressures in the power plant are taken as the average of those found in the literature [13]. The pressure at the boiler exit is 16550 kPa and at the exit of the condenser is 10 kPa. The outlet temperature of the boiler is 800 K. The temperature after the low pressure pump (T_6) is 319K (46°C). Any heat added through the main heat exchanger would then result in an increase of temperature from T_6 to T_7 (viz. Figure 2). The evaporating temperature (microevaporator and HS in the blades) will vary between 298K and 333K (25°C and 60°C) and the condensing temperature (in the MHE) between 320K and 363K (47°C and 90°C). For the evaluation of partial operation of utilities, the operation/load of the datacenter and power plant will vary between 50% and 100% of the maximum load.

2.2. Assumptions

The analyses were performed considering an overall energy balance (first thermodynamic law) in the circuits showed in Figure 1. The main parameters evaluated are presented in Table 1 and the following assumptions are made to perform the simulations:

- no pressure drop in the components and piping;
- no heat loss in the piping;
- 60% isentropic efficiency of the compressor;
- isentropic pumping;
- isenthalpic expansion;
- 1 K of subcooling at the inlet of pumps;
- heat load equally shared between chip and additional electronic components in the blade (150 W each);
- 95 % effectiveness for LPR and iHex;
- output of the MHE in the datacenter side is saturated liquid.

The simulations were performed with the power plant coupled either with the vapour compression cycle or the liquid pumping cycle, both using HFC134a as a working fluid, one of the best fluids regarding datacenter performances [14].

Table 1: Main variables used in the study

| | |
|---------------|--|
| T_{cond} | Condensing temperature |
| T_{evap} | Evaporating temperature |
| N_{blade}^o | Number of blades in the datacenter |
| ϵ | Effectiveness of the main heat exchanger |
| η | Efficiency of the power plant |
| W_{elec} | Electrical power produced by the power plant |

It is also important to define the effectiveness (ϵ) of the main heat exchanger, which is given by Equation 1. The temperatures T_6 , T_7 and T_{in} , are inlet and outlet temperatures at the power plant side and inlet temperature at the cooling cycle side, respectively (*viz.* Figure 1). For the cooling cycle side, the inlet flow can be either two-phase (LP cycle) or superheated vapour (VC cycle). The temperature T_7 is obtained from the enthalpy h_7 , which is determined from an energy balance in the MHE.

$$\epsilon = \frac{m_{pp} \times cp_{pp} \times (T_7 - T_6)}{(m \times cp)_{min} \times (\Delta T)_{max}} = \frac{T_7 - T_6}{T_{in} - T_6} \quad (1)$$

In this equation, m_{pp} and cp_{pp} are respectively the mass flow rate and the average specific heat on the power plant side. The equation can be simplified, as can be seen after the second equality, because the term $m_{pp} \cdot cp_{pp}$ is equal to $(m \cdot cp)_{min}$ in the simulations considered.

2.3. Simulations

For the simulations two possible scenarios were considered, as described below and highlighted in the flowchart of Figure 2.

- **“Perfect match”** simulation (dashed line in Figure 2). For fixed operating temperatures (T_{cond} and T_{evap}), fixing the value of N°_{blade} will lead to the value of W_{elec} and vice versa. In this option the maximum potential benefits from coupling the power plant/datacenter cooling system is obtained, since the effectiveness of MHE is fixed to 100%.

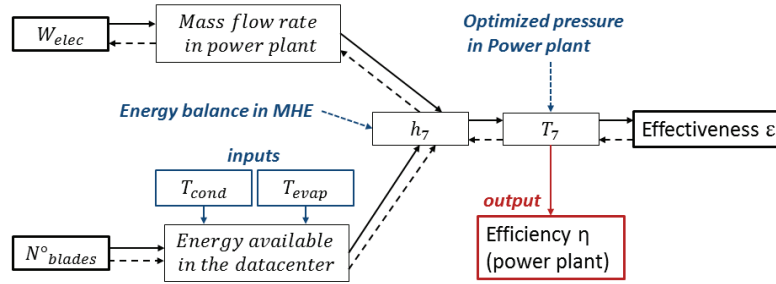

Figure 2: Simulation possibilities

- **“Practical case”** simulation (solid line in Figure 2). Starting from a predetermined size of the power plant (maximum electricity production) and datacenter (number of blades) and fixed operating conditions (T_{cond} and T_{evap}), the effect of partial operation of either power plant or datacenter is evaluated on the performance parameters (heat exchanger effectiveness, overall utilities efficiencies, CO₂ footprint, monetary savings).

The next section will consider such possibilities for the simulations and analyses.

3. Effects of evaporating and condensing temperatures

3.1. Datacenter cooling cycle

Olivier *et al.*[11] showed that the cycle using a vapour compressor is a strong function of the compressor’s overall efficiency, up to a value of approximately 35% after which it becomes less dependent. Typically, compressors have an overall efficiency of about 60%. The liquid pumping cycle hardly shows any dependence on the pump efficiency. This was justified due to the power required to drive the pump being very low [14].

In the following simulations, the values of the compressor and pump overall efficiencies are fixed at 60% and 100% respectively. In this work, the effects of the condensing and evaporating temperatures on the datacenter power supply requirements are investigated for a datacenter of 100 000 blade servers (300W per blade server). It is important to notice that due to datacenter growth, it is more than likely to see datacenters in excess of 100 000 blade servers (Olivier *et al.*, 2010).

Figures 3 and 4 present the results obtained considering the two cooling cycles (VC and LP) and the current air cooling technology (AC). Condensing temperatures from 320K to 363K for an evaporating

temperature in the VC cycle of 363K (viz. Figure 3) and evaporating temperatures from 298K to 333K for a condensing temperature of 363K in the VC cycle (viz. Figure 4) were considered. It is assumed that the power consumption of air cooling technology is 45% of the whole consumption of the datacenter [3]. The simulation is considered as a “*perfect match*” ($\epsilon=100\%$) since the size of the datacenter and operating temperatures are input variables.

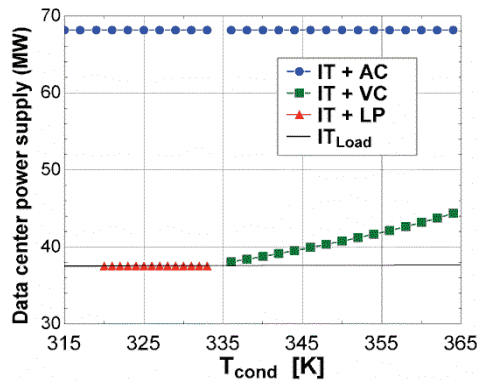

Figure 3: Influence of condensing temperature
(VC: Evaporating temperature = 60°C)

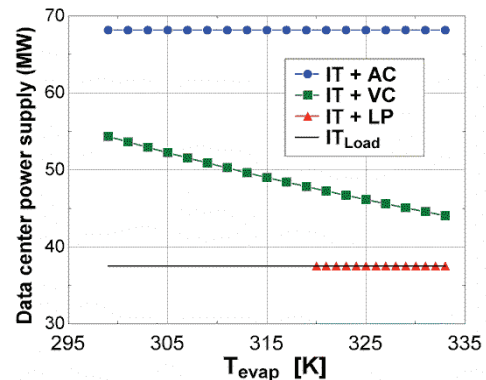

Figure 4: Influence of evaporating temperature
(VC: Condensing temperature = 90°C)

For the LP cycle, the condensing and evaporating temperatures seem to have negligible effects on the datacenter power supply. Such a result is associated with the very low power required to drive the pump. The total power supply (IT + LP), in this case, has a huge reduction (about 45%) when compared with the air cooling technology (IT + AC). For the VC cycle, the datacenter power supply requirement decreases when T_{evap} increases and T_{cond} decreases. This result was expected since the higher the temperature difference, the higher the pressure difference becomes, resulting in more work required from the compressor (far from the ideal cycle, i.e. Carnot cycle). The savings in power supply, for an evaporating temperature of 60°C (333K) and a condensing temperature of 90°C (363K), are of about 35% when compared to air cooling technology.

In summary, the results show that when energy recovery is not taken into consideration, the LP cycle is the better solution for cooling datacenters.

3.2. Power utility

Heat captured in the datacenter can be reused by a power plant. Since the waste heat of the datacenter is of a low quality, it can only be inserted after the condenser of the power plant. This would then increase the temperature of the water leaving the condenser to a maximum temperature as defined by the condensing temperature of the datacenter cycle. Therefore, any additional heat added to the power plant’s cycle will result in less fuel being burnt, thus saving fuel and reducing the CO₂ footprint of the power plant.

At this point in stage, it would appear that the use of a liquid pumping cycle far outweighs the vapour compression cycle. This is true when only considering the datacenter, but when it comes to energy recovery through the power plant, the higher outlet exergy of the VC cycle leads to more benefits for the power plant. This is shown in Figures 5 and 6 where the effects of the condensing temperature and evaporating temperature on the power plant efficiency are presented, respectively. The simulation is a “*perfect match*” ($\epsilon=100\%$), where the size of the datacenter (100000 blade servers) and operating temperatures are input variables. The efficiency of the power plant, without considering the energy recovered from the datacenter, is 45.5%.

Figure 5 shows that a higher condensing temperature results in higher power plant (PP) efficiency. The PP efficiency can be improved by up to 3.7% if the datacenter’s waste heat is reused in the power plant. By using a liquid pumping cycle in the datacenter, a maximum of 60°C (333K) of condensing temperature can be reached (limit used to avoid the maximum chip temperature of 85°C [9]). For higher condensing temperatures, a vapour compression cycle would be required. When looking the effect of the evaporating temperature, the improvements can be much higher as can be seen in Figure 6.

Improvements of up to 6.5% are obtained when considering the VC cycle and 298K and 363K of evaporating and condensing temperatures, respectively.

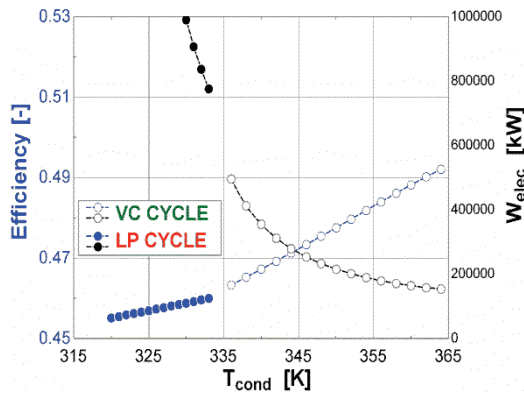

Figure 5: Influence of condensing temperature on power plant efficiency ($T_{evap} = 60^{\circ}C$)

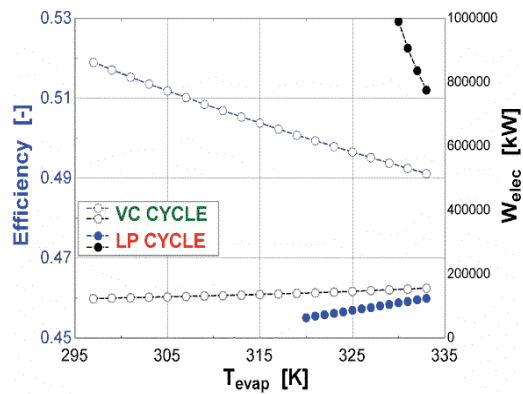

Figure 6: Influence of evaporating temperature on power plant efficiency ($T_{cond} = 90^{\circ}C$)

The ideal case for using a LP cycle would be to couple a datacenter with 100000 blade servers to a 770 MW power plant, with a power plant efficiency increase from 45.5% to 46%. This is for a condensing temperature of 333K. For the VC cycle the maximum efficiency obtained would be 52%, when condensing and evaporating temperatures of the 298K and 363K respectively are considered. For such a cycle, a 130 MW power plant size is necessary.

It can also be observed that the VC cycle exhibits more benefits when it comes to energy recovery. A higher improvement in efficiency was obtained for a smaller power plant size. This result reflects the higher exergy available in the heat recovered when using a VC cycle. In other words, it can be said that to use all the available exergy of the datacenter in the condenser when using a liquid pump as a driver, it is necessary to couple the datacenter cooling system to a much bigger power plant than when using a vapor compressor. And the biggest drawback is that the improvement in efficiency is lower (*viz.* Figures 5 and 6).

The next two sections will evaluate the benefits of the power plant / data center cooling system synergy in terms of carbon footprint and monetary savings. The same inputs will be considered, i.e. datacenter size and condensing and evaporating temperatures (“*perfect match*” simulation).

3.3. Carbon footprint

For the calculation of the carbon footprint, only the contribution of the electricity used is considered. The effect of greenhouse gases (GHG) being formed by the manufacturing, transporting, storage and disposal of the components of the datacenter, as well as the datacenter building, fall under the Life Cycle Assessment, which falls outside the scope of the current paper. Further, of the greenhouse gases, only CO₂ will be considered as it contributes to more than 75% of all the greenhouse gases and contributes the most to the greenhouse effect.

With the same inputs as for the “*perfect match*” simulations performed beforehand, the carbon footprint of both datacenter and power plant was investigated. Again, evaporating and condensing temperature effects were evaluated. For the datacenter, the results are plotted in terms of CO₂ savings in comparison with air cooling technology. For the power plant, as its size is changing with the operating temperatures, the results are plotted in terms of mass of CO₂ consumed per kWh produced (*viz.* Figures 7 and 8). The specific consumption of the power plant without considering the energy recovered of the datacenter is 0.8435 kg CO₂ per kWh.

The quantity of CO₂ is calculated with the assumption that the datacenter purchases its electricity from a power plant running on coal and that it is selling waste heat back to the power plant, as discussed earlier. The graphs, therefore, take into consideration the efficiency increase of the power plant, since the amount of CO₂ released is in accordance with the power plant’s efficiency, which in itself is a function of the efficiency with which energy is recovered.

Since the power plant’s thermal efficiency improves with an increase of the condenser temperature, the amount of CO₂ saved by the power plant increases (*viz.* Figure 7). However, when using a LP cycle

for the datacenter, the potential savings in CO₂ that can be achieved in the power plant are always smaller than when using a VC cycle. Therefore, although the liquid pumping cycle was the better performing cooling cycle regarding energy usage (viz. Figures 3 and 4) and CO₂ reduction, the higher achievable temperatures of the VC cycle have a larger impact on the secondary application making use of the waste heat. A similar analysis can be performed when looking for the evaporating temperature variation (viz. Figure 8), where a lower evaporating temperature, when using a VC cycle, showed a much higher potential savings in CO₂ in the power plant size.

Therefore, at a condensing temperature of 333K, the LP cycle exhibits savings of 230 000 tons of CO₂ for the datacenter and 65 500 tons of CO₂ for a 770 MW power plant per year. For the VC cycle (condensing temperature of 363K and evaporating temperature of 333K), the savings are about 210 000 tons of CO₂ for the datacenter and 72 000 tons of CO₂ for a 130 MW power plant. Such results show, when looking from the power plant's perspective, that the potential savings of CO₂ are much higher when using a VC cycle. For the example above, if we consider the total savings of CO₂ (PP and DC) per MW of electricity production we would have 384 tons of CO₂ per MW when using the LP cycle against 2170 tons of CO₂ per MW when using the VC cycle.

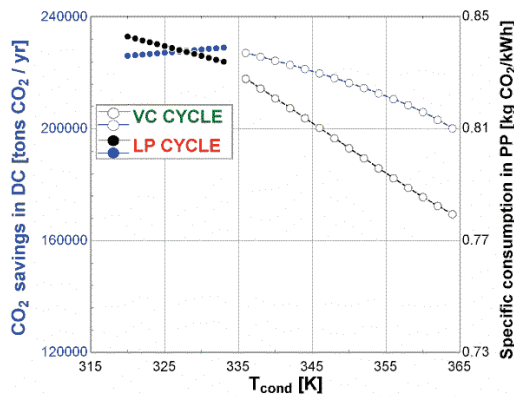

Figure 7: Influence of condensing temperature on carbon footprint

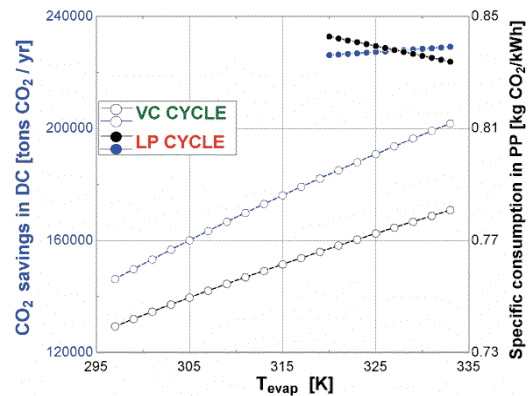

Figure 8: Influence of evaporating temperature on carbon footprint

3.4. Monetary savings

Global warming is having a huge impact on the environment and on people's livelihoods regarding food production and natural resources. To counter this, a carbon tax is being introduced, which is aimed at helping the environment by not only reducing carbon emissions by forcing people and organizations to become more energy efficient, but also by raising funds to be used for clean energy research. The tax is levied on the carbon content of fuels, increasing the competitiveness of non-carbon technologies such as solar, wind or nuclear energy sources. Therefore, organizations using electricity produced from the burning of fossil fuels will pay a higher tax than those produced from non-carbon burning fuels. The probability also exists for taxing the utility generating the electricity. Carbon taxes have only been introduced in a few countries, with most European nations taking the lead, even though the way organizations are being taxed vary from country to country. In the United States the introduction of carbon tax has been made in California and the city of Boulder, Colorado, with taxes being in the order of 4 cents/ton of CO₂. Europe has been much more stringent with taxes in some countries, such as Sweden, being as high as \$100 per ton of CO₂. The Larson Bill [15] proposes to introduce a nationwide tax (US) of \$15/ton CO₂ starting in 2012, increasing by \$10/ton CO₂ every year. It also proposes to increase this increment to \$15/ton CO₂ after 5 years if the US emissions stray from the Environmental Protection Agency's (EPA) glide-path prediction, which proposes to cut emissions to 80% that of 2005 levels by 2050 [1].

With a recommended price of \$30/ton, CO₂ [16] could cost industries millions if efficiencies are not improved. Datacenters are also not exempt from these taxes, which will be introduced in the years to come [17]. Figures 9 and 10 present the savings of the datacenter in comparison with the air cooling technology and the specific price to produce 1 kWh of electricity for the power plant. The specific price of the power plant without considering the energy recovered of the datacenter is 0.0545 \$ per kWh.

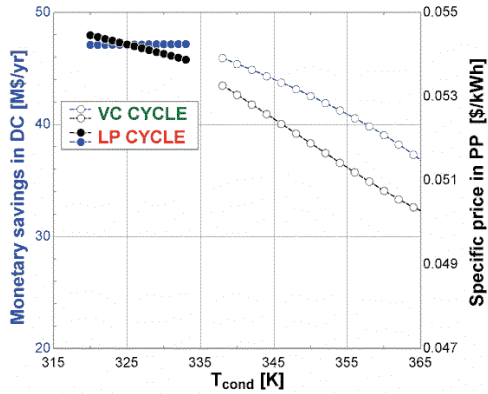

Figure 9: Influence of condensing temperature on monetary savings

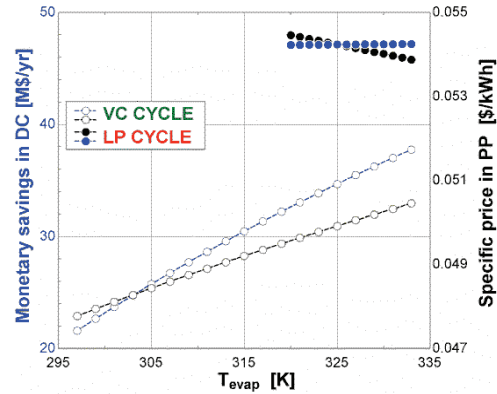

Figure 10: Influence of evaporating temperature on monetary savings

For fuel costs, a value of \$90/ton of coal was used. The savings not only include what has been saved in energy costs by implementing a liquid pumping or vapour compression cycle instead of a traditional air cooling cycle, but also what has been saved in carbon tax. The cost of electricity production in the power plant considers the fuel saved and the savings made in carbon tax. The same conditions used in sections 3.1 to 3.3 are considered here, i.e. “perfect match” simulations.

From the datacenter’s point of view, Figures 9 and 10 show that higher savings can be obtained when considering the LP cycle, which is expected due to the lower input power for the driver (pump). However, the cost of electricity production in the power plant is much higher. From the power plant’s point of view, the figures show that it is better to work with the VC cycle and consider high condensing temperature and low evaporating temperature.

For the same temperatures considered in the previous item, the savings are about \$47 million for the datacenter (using the LP cycle) and \$4.2 million for the 770 MW power plant. When using the VC cycle (condensing temperature of 363K and evaporating temperature of 333K) and the 130 MW power plant, the savings are about \$38 million for the datacenter and \$6.5 million for the power plant. Computing the overall savings (PP and DC) per MW of electricity production the results show an increase of more than 4 times in monetary savings when using the VC cycle, i.e. \$0.07 million/MW when using the LP cycle against \$0.34 million/MW when using the VC cycle.

Therefore, although the liquid pumping cycle was the better performing cooling cycle regarding energy usage and CO₂ reduction, due to the higher temperatures achievable, the vapour compression cycle has a larger impact on the secondary application making use of the waste heat. It can also be said that the incentive for a power plant to cooperate with a datacenter would be greater if a vapour compression cycle was used.

4. Utilities partial operation effects

To evaluate the effect of the partial operation of the utilities (PP and DC) on the PP efficiency and MHE effectiveness, the “practical case” simulation described in the section 2.3 will be used. An ideal match between datacenter size (100 000 blades) and power plant (130 MW) was defined from the previous analysis as a starting point. The VC cycle was used for such simulation considering 333K and 363K as evaporating and condensing temperatures respectively.

Two cases were evaluated: first the power plant electricity production was kept constant and the datacenter heat load (computing power requirement) was progressively decreased from 100% to 50% of the maximum. To represent the partial operation of the datacenter, a reduction of the datacenter size, i.e. number of blades, was considered. The second case investigated was for the datacenter operating at full load and the power plant electricity production being reduced from 100% to 50% of the maximum production. Figure 11 shows the behaviour of the PP efficiency and MHE effectiveness when the two cases are simulated. It is important to mention that similar results were also obtained with the LP cycle.

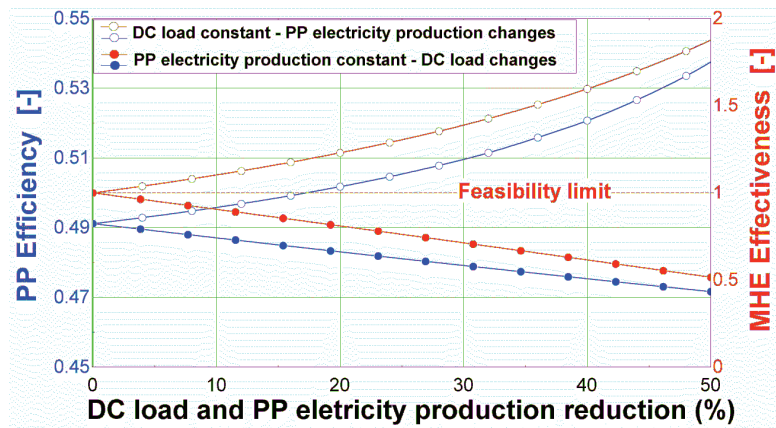

Figure 11: Partial operation effects

For the first case, where the datacenter load is reduced at a constant power plant electricity production, it can be seen that there is a decrease of the PP efficiency and MHE effectiveness. This means that the MHE is not working at its optimized operating conditions but the coupled system (PP + DC) continues working properly.

For the second case, it can be observed that PP efficiency and MHE effectiveness increase when the PP electricity production is reduced. However, a thermodynamic inconsistency is observed as the MHE effectiveness becomes higher than 100%, i.e. an unfeasible operation. This means that the power plant is not large enough to remove all the heat from the condenser of the DC cooling cycle. In a real operation, the consequence on the cooling cycle due to the limitation in the heat transfer in the condenser will be an increase of condensing and evaporating temperatures, a reduction of cooling cycle performance, and possibly an increase of chip temperature (undesirable due to reliability criteria). Thus, this result shows that for safe operation, the matching between PP and DC (coupled system) must be such that the MHE effectiveness is lower than 100%. An alternative solution could be the implementation of a secondary loop with cold water to remove the extra heat that was not transferred to the PP. However, such a decision (design for MHE effectiveness lower than 100%, alternative solution ...) is very specific, normally associated with local economic and environment aspects.

Figure 12 presents a feasibility map for the coupled system, i.e. DC and PP sizes. The LP and VC drivers were considered in the construction of the map. For the LP cycle, condensing temperatures of 323K and 333K are shown and for the VC cycle two pairs of evaporating and condensing temperatures are considered, i.e. (298K, 363K) and (333K, 353K). To summarize, the map needs to take into account the sizes of the datacenter and power plant, the types of cooling cycle operating in the datacenter (VC or LP) and the operating temperatures. The plotted curves represent the perfect matching between the datacenter and the power plant, i.e. MHE effectiveness of 100%.

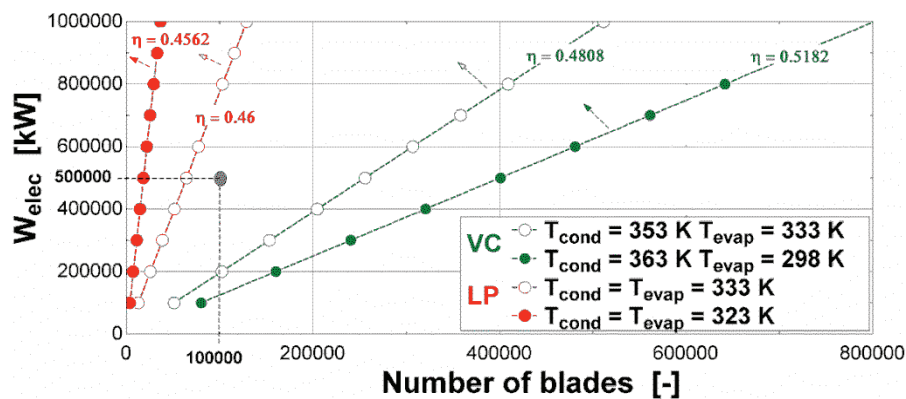

Figure 12: Validity domain for different operating temperatures

The curves plotted in Figure 12 represent the limit of operation for the coupled system and operating temperatures considered. If a coupling between power plant (electricity production) and datacenter (number of blades) is such that it falls to the right side of the curves, it means that the MHE effectiveness is greater than 100%, i.e. the power plant is not large enough for the given size of the datacenter and it is not possible for the coupled system to operate at these operating temperatures. In the figure, the arrows indicate the region on the map where the coupled system is feasible for the operating temperatures considered. The map can be used to show the advantages of the VC cycle over the LP cycle when considering energy recovery through a coal-fired power plant. For usual sizes of 500 MW PP and 100 000 blades DC (*viz.* grey point on Figure 12), the LP cycle cannot operate independently of the operating temperatures considered. Contrarily, the VC cycle operates for both operating temperatures considered in the present map, in this case for MHE effectiveness lower than 100 %. Finally, it is observed that the map, besides helping to decide on the best coupling and operating condition, also shows that when using a VC cycle to cool the datacenter the range of feasibility is larger and the PP efficiency is much higher than when using a LP cycle.

5. Conclusion

This paper investigated the potential savings in energy a datacenter can make by implementing on-chip cooling with waste heat recovery as an alternative to traditional air-cooling. The investigation considered on-chip cooling cycles making use of a liquid pump and a vapour compressor as the main fluid driver. As an application for the waste heat, a coal-fired power plant was analysed. Aspects such as energy consumption, energy recovery, carbon footprint and power plant efficiency were investigated.

The results showed that, when compared with traditional air-cooling systems, the energy consumption of the datacenter, without considering energy recovery, can be reduced by as much as 45% when using a liquid pumping cycle and 35% when using a vapour compression cycle. In the previous work, Olivier et al. [11] showed that with the energy recovered this value could be reduced even further (potential to sell the heat recovered).

When the waste heat from the datacenter was recovered by a thermal coal-fired power plant, better results were obtained when a vapour compression cycle was considered. Improvements of up to 6.5% for the PP efficiency were observed when the “perfect match” between the power plant and datacenter and the VC cycle were considered. The liquid pump cycle showed that a much larger power plant is necessary for the same datacenter size and that it exhibits much less efficiency improvements.

Additionally, it was shown that higher carbon footprint and monetary savings are obtained when the vapour compression cycle is considered. The total savings (PP and DC) were 2170 tons of CO₂/MW and \$0.34 million/MW of electricity production when using the VC cycle and 384 tons of CO₂/MW and \$0.07 million/MW when using the LP cycle. The total savings include the reduction in energy (DC) and fuel (PP) consumption and the savings associated with the reduction in the carbon footprint.

A feasibility map was constructed to show the region of feasible application for the coupled system (DC and PP). It highlighted the importance of not only the correct matching between PP and DC, but also the importance of the cooling cycle operating conditions, condensing and evaporating temperatures, so that the coupling can be thermodynamically possible and the improvements in efficiency can be maximized.

To summarize, when the energy recovery was taken into account, it was proven that the VC cycle applied on the datacenter shows better overall improvements of the PP efficiency, monetary savings and minimization of CO₂ footprint. It was also shown that when energy recovery is not considered, the better driver for the DC cooling cycle is the liquid pump. Finally, it is important to mention that the incentive for a secondary application to use the waste heat from datacenters will be greater when a vapour compression cycle is used due to the quality of its energy being higher.

The future perspective of this work is to study different secondary applications such as district heating and cooling and test the influence of other refrigerants in the cooling cycles. The use, for example, of working fluids with a higher supercritical point than HFC134a would lead to even higher condensing temperatures when using the vapour compression cycle, with higher efficiency improvements.

References

- [1] EPA, 2007. "Report to Congress on Server and Data Center Energy Efficiency Public Law", 109-431, U.S. Environmental Protection Agency.
- [2] Utsler, J., Chips in 3D, in IBM Systems Magazine, in press. 2010.
- [3] Koomey, J.G., 2007. "Estimating Total Power Consumption by Servers in the U.S. and the World", Analytics Press, Oakland, CA, February 15 (<http://enterprise.amd.com/us-en/AMD-Business/Technology-Home/Power-Management.aspx>).
- [4] Saini, M. and Webb, R.L., 2003. "Heat Rejection Limits of Air Cooled Plane Fin Heat Sinks for Computer Cooling", *IEEE Transactions on Components and Packaging Technologies*, 26(1): p. 71-79.
- [5] Agostini, B., Fabbri, M., Park, J.E., Wojtan, L., Thome, J.R. and Michel, B., 2007. "State-of-the-art of High Heat Flux Cooling Technologies", *Heat Transfer Engineering*, 28: p. 258-281.
- [6] Leonard, P.L. and Phillips, A.L., 2005. "The Thermal Bus Opportunity – A Quantum Leap in Data Center Cooling Potential", in *ASHRAE Transactions*, Denver, CO.
- [7] Marcinichen, J.B., Olivier, J.A. and Thome, J.R., 2011. "Reasons to use two-phase refrigerant cooling", *Electronics Cooling*.
- [8] Park, J.E., 2008. "Critical Heat Flux in Multi-Microchannel Copper Elements with Low Pressure Refrigerants", PhD Thesis, École Polytechnique Fédérale de Lausanne, Switzerland.
- [9] Madhour, Y., Olivier, J.A., Costa-Patry, E., Paredes, S., Michel, B. and Thome, J.R., 2010. "Flow Boiling of R134a in a Multi-Microchannel Heat Sink with Hotspot Heaters for Energy-Efficient Microelectronic CPU Cooling Applications", *IEEE Transactions on Components and Packaging Technologies*, Accepted for publication.
- [10] Cullen J.M. and Allwood J.M., 2010. "Theoretical efficiency limits for energy conversion devices", *Journal of Energy*, 35: p.2059-2069.
- [11] Olivier, J.A., Marcinichen, J.B. and Thome, J.R., 2010. "Two-phase cooling of Datacenters: Reduction in Energy Costs and Improved efficiencies", *Proceeding of ENCIT 2010*.
- [12] Marcinichen, J.B., Thome, J.R. and Michel, B., 2010. "Cooling of Microprocessors with Micro-Evaporation: A Novel Two-Phase Cooling Cycle", *International Journal of Refrigeration*.
- [13] EPRI, 2011. "Development of innovative technologies for cooling, waste heat utilization, water treatment, and water resource expansion to reduce power sector water use". EPRI's Office of Innovation. Available from <http://my.epri.com/portal/server.pt>.
- [14] Marcinichen, J.B. and Thome, J.R., 2010. "New Novel Green Computer Two-Phase Cooling Cycle: A Model for Its Steady-State Simulation", in *Proceedings of the 23rd International Conference on Efficiency, Cost, Optimization, Simulation and Environmental Impact of Energy Systems - ECOS2010*, Lausanne, Switzerland.
- [15] Larson J.B., 2009. "America's Energy Security Trust Fund Act of 2009", H.R. 1337.
- [16] Nordhaus, W., 2008. "A Question of Balance – Weighing the Options of Global Warming Policies", Yale University Press, New Haven.
- [17] Mitchel, R.L., 2010. "Carbon Tax could Whack Data Centers", *Computerworld*,