



# Spatial echogram analysis of a small auditorium with observations on the dispersion of early reflections.

Xavier Falourd<sup>1</sup>; Lukas Rohr<sup>1</sup>; Mario Rossi<sup>1</sup>; Hervé Lissek<sup>1</sup>

<sup>1</sup>EPFL – STI - LEMA, CH-1015 Lausanne, Switzerland  
e-mail: [xavier.falourd@epfl.ch](mailto:xavier.falourd@epfl.ch)

## Abstract

Classical room acoustics are based on the interpretation of different sound attributes such as reverberation time, clarity and spatial decay. Based on echograms calculated from a microphone array, the dispersion of early reflections is measured and the reflections are identified. In small auditoriums, the method delivers some comprehensive information of the acoustic paths between the source and the microphone array qualifying global and local characteristics of the room boundaries. Results validate the process and highlight its contributions, but also the difficulties of implementation.

**Keywords:** Microphone Array, Acoustic Source Localization, Time Difference Of Arrival, Direction Of Arrival, Spatial Echogram, Room Acoustics, Early Reflection.

## 1 Introduction

To offer listeners optimal listening conditions in rooms or small auditoria, the acoustician uses indices which describe the sound field. These methods, usually based on the impulse response evaluated between one source and one microphone following geometric acoustic principles, allow the calculation of the room acoustic parameters: reverberation time, clarity, early decay time, signal-to-noise ratio, etc. To allow an objective comparison between rooms these indices have been standardized and are set out by the standards ISO 3382-1 [1] and 3382-2 [2]. These standards require different measurement points depending on the studied rooms. However, indices such as EDT (Early Decay Time) or clarity strongly depend on early reflections usually contained in the first fifty milliseconds after the first wave front, which follows the direct path between the source and the microphone.

Current tools estimate with great accuracy the different temporal dispersions of early reflections, but knowledge of their spatial distribution is more difficult to obtain even though it is a major asset for the qualification of a room or of architectural changes aimed at improving listening quality listening (Figure 1).

## 2 Localization of early reflections

Previous work demonstrates the possibility of simultaneous localization of several early reflections by chrono-goniometry [3]. The main strategy to discriminate early reflections in time and space is based on the ability to measure the time of arrival (TOA) of wave fronts impacting an array of microphones. The algorithm relies on TOA estimation to retrieve through geometrical assumption the direction of arrival (DOA) of each detected wave front. Under the far-field assumption, the analysis of the echograms and their combinations allows detection of all reflections on the walls of the room as well as assigning them to a particular wall. A preliminary study on early reflections was conducted in two large spaces: the Cathedral in Lausanne and the Stravinsky auditorium in Montreux. The large sizes of both of these rooms induce a low temporal density of early reflections, which facilitates their identification.

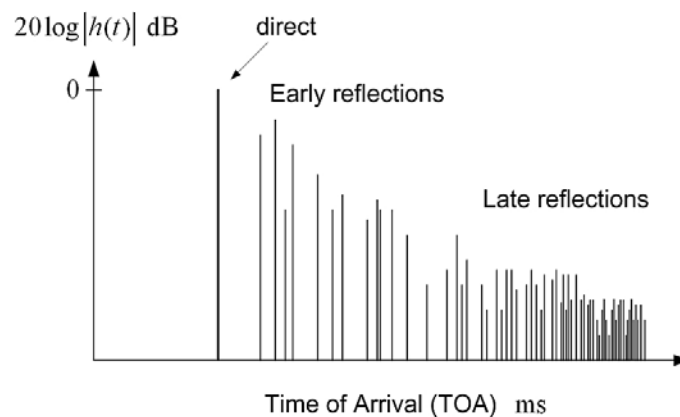

Figure 1 – Echogram and ray arrivals

The method of measurement however should not only be applicable to large spaces, but should be extended to smaller rooms and auditorium presenting a large number of reflections in the first 50 milliseconds. The existing algorithm has therefore to be adapted for small rooms requiring several improvements in the calculation modules.

Finally the inverse interpretation of the detected wave fronts based on their acoustic paths, should provide some overall information on room properties such as geometry and global or local characteristics of the identified reflecting surfaces.

## 3 Validation of the use of an image source method

One of the first simulation models for propagation and reflection was proposed by Allen & Berkley in 1979 [4]. The image source model assumes that all reflections are specular, which limits its use to the frequency band of geometric acoustics. A coupling of this model with the proposed chrono-goniometer could be of interest by increasing its resolution and giving additional information about in situ measurements.

### 3.1 Spatial scanning

To validate the calculations based on assumption of image sources, the impulse response of a rectangular room was measured by a linear array of microphones on a transverse line corresponding to the width of the room. The impulse response is estimated at each measurement point by correlation between white noise emitted by the source and collected sound on each microphone. It provides a synthesis of the generated sound field by analysis of the first wave fronts due to the early reflections on the walls. Impulse responses found on the room width are then concatenated forming the multi-trace impulse response (MTIR) of the room for a given source position [5]. The incident wave fronts can thus be viewed and analyzed by comparison with the image source model.

The experience is conducted in a small room similar in dimensions to a mobile broadcasting studio. It is built in wood panels and its size is 3.40 x 2.15 x 2.10 m (Figure 2). The homogeneity of the walls provides an average absorption factor allowing the overall analysis of the room. Furthermore, the small size of the room gives rise to a great temporal density of the early reflections which are visible on the echogram.

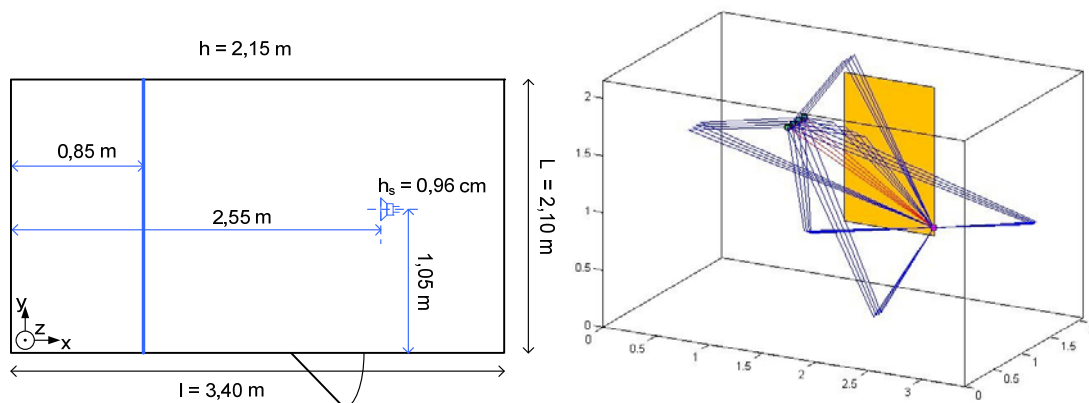

Figure 2: left, room geometry and location of the source; right, potential acoustic paths between the source and four microphones.

### 3.2 First wave fronts – early reflections scanning

Under conditions of homogeneity of each room wall surfaces, temporal characteristics of all detected front waves are of interest to evaluate the MTIR shown on Figure 3 (left).

The direct path is easily identifiable by its arrival time and energy along the width of the room. Following the first ray, a low number of reflections wave fronts are also identifiable considering their curvature and their spatio-temporal distributions. One denotes quiet easily the measured arrival times associated to reflections on the walls and ceiling and floor room.

It has been observed a short delay of approximately  $600\ \mu\text{s}$  found between the simulated response and measured response; this delay can be attributed to different latency times present in the processing chain: impulse response, delays of source filters, etc.

The comparison between model from MTIR and measure emphasizes their good consistency for the first wave fronts. But for large number of reflections, it illustrates the need for an adjustment of geometrical and physical parameters. The simulated paths associated to the detected TOA of early reflections are then fully in accordance with the initial hypothesis : the detection of the different ray paths in the room can be fully describe by a spatial and temporal description.

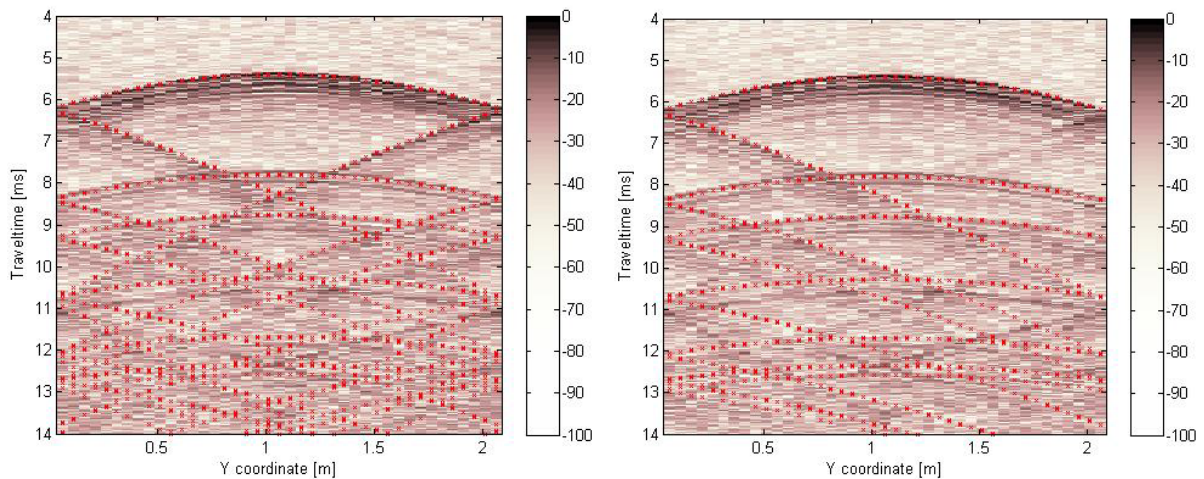

Figure 1 : left, MTIR of the homogeneous room; right, MTIR with one heterogeneous wall. Color scale is relative to amplitude, red dots are simulated rays.

### 3.3 Early reflections amplitudes, simple

Interest is focused on the measurement of the amplitudes of the early reflections between source and microphone. Under the same conditions as previous measurements except a local treatment by a panel of mineral wool on a wall of the room, the interest is focused on the change of amplitude for early reflections impacting the panel (Figure 3, right).

The extent of the MTIR again demonstrates good consistency between simulated data and measured data regarding the loss of amplitude due to an absorbing surface on early reflections. However as the finite width panel determines a small surface compared to the wall and since the simulation engine assumes the wall homogeneous, some reflections are observed in opposite to the simulated MTIR.

### 3.4 Comments

These experiences helped to highlight several points of importance in improving the characterization of early reflections algorithm using an array of microphones; the main points of importance are:

- MTIR has to be spherical model based in the localization module of early reflections.
- MTIR reveal a remarkable symmetry and indicate polling places enhancing the temporal discrimination of the different wave fronts; locations of microphones are based on the room geometry and the location of the source.
- Measurements made with absorbent panel clearly indicate the importance of controlling the qualification and the quantification of energy estimated in the echogram.
- The direct problem based on source images model is of relevance to enhance significantly performance of the chrono-goniometer when coupled to real measurements.

## 4 The cubic array

### 4.1 Description

The laboratory has developed a cubic antenna composed of eight microphones which has been used in previous studies (Figure 4). Coupled with a localization algorithm, this cubic arrangement allows measuring the impact of a front wave with an angular resolution less than five degrees [3, 6]. The existing algorithm based on difference time of arrival (DTOA) of planar waves impacting microphones is not suitable for small rooms since of far-field assumptions.

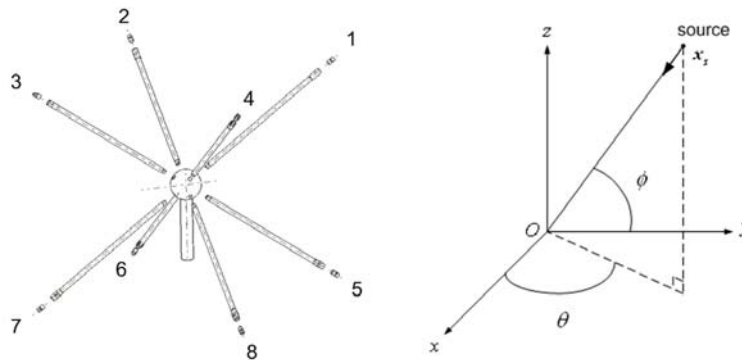

Figure 4: Cubic microphone array and its coordinate system

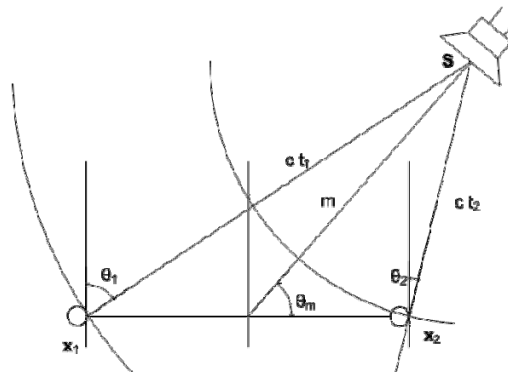

Figure 5: Stewart theorem geometry

### 4.2 Algorithm renewal: the spherical approach

Following the theorem of Stewart, a new wording is defined in module localization to formulate the spherical propagation model available for any source outside of the cubic arrangement. More robustness is enhanced by optimizing a geometric constraint checking relationship (1). Thus a criterion on the relationship between arrival angles relative to four pairs of microphones along the diagonals of the cube allows effective combinatorial treatment of TOA extracted in the echograms. Indeed, the geometry of the antenna stipulates the following relation [7]:

$$\sum_{n=1}^4 \cos^2(\theta_{mp}) = \frac{4}{3} \quad (1)$$

Despite the obtained theoretical robustness, certain set of solutions are always rejected by the algorithm, some settings such as the threshold in the detection of rays and one geometric tolerance have to be adjusted within certain physical or user defined bounds. This need for adjustment resulted in integration algorithm in a graphical interface for the user immediate visualization results measurement for decision-making in situ.

### 4.3 Interfacing

The Matlab interface (Figure 6) developed in the framework of the project calculates:

- echograms associated to the eight microphones,
- azimuths and elevations of detected wave fronts,
- spatio-temporal diagrams,
- usual acoustic indices.

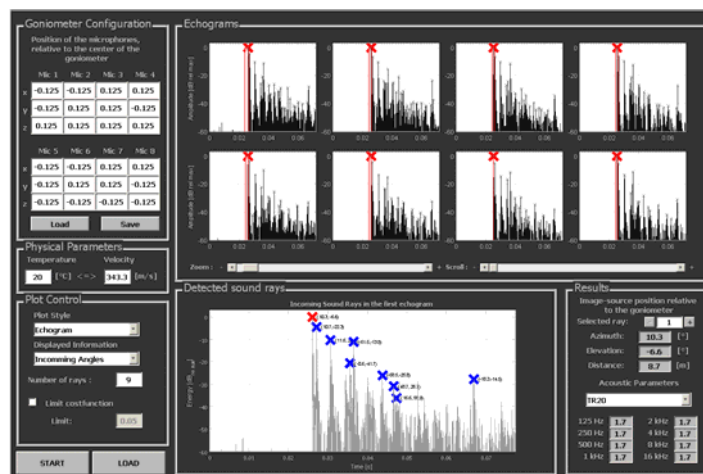

Figure 2 : matlab interface associated to the cube array

### 4.4 Synchronization and calibration

In order to characterize otherwise compensate the impulse response of all the devices, a speaker is located in the center of the antenna. It beeps MLS for synchronization of different acquisition and generation audio devices, but too for the self-calibration of electro-acoustic materials.

### 4.5 Preliminary test in the small room

Measurements were made in the small room (Figure 2) to test the interface. According to previous MTIR the cubic array of microphones was placed outside of all planes of symmetry of the room to get some large differences of TOA for early reflections. Finally, detected rays in the echogram and their associated DOA calculated by the new module are indicated on the figure 9. These locations correspond in part to direct path and the early reflections expected by the model, but also to false rays. Moreover some energetic rays are not identified in the echogram then not treated as a physical wave front. But this drastic scenario, because of very small distance between source and microphone and large number of reflections, presents some good potential to measure and locate in situ early reflections in the first 50 ms of an echogram.

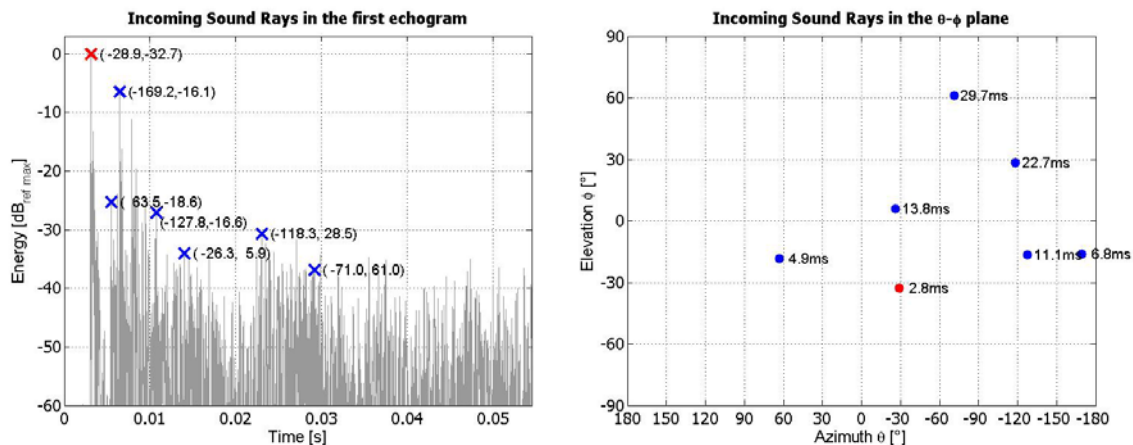

Figure 3 : Left, echogram and identified rays – red cross the direct ray, blue ones reflected rays. Right, spatio-temporal diagram of detected rays.

#### 4.6 Montreux auditorium measurements

Despite a room geometry not ideal for the purposes of modelling, the Visinand House in Montreux was the measure to assess acoustic impact on early reflections of curtains located on one side and at the back of the room. The analysis of the echogram at different locations has been done to validate the spatio-temporal discrimination of the algorithm in situ.

The figure 10 and figure 11 illustrate respectively echograms measured on one location for the different conditions : without curtains and with curtains. Finally the residual echogram (figure 12) calculated by the difference of the two echograms permits to observe the contribution of curtains and to locate and to qualify the impact of curtains. It is remarkable in figure 12 that the residue of the echograms with no curtains consists mainly of reflections on the wall and the full room. Therefore, the influence of these curtains in the calculation of acoustic indices can be estimated on site.

The results highlight the expected influence of curtains on the reverberation time. This measurement principle could be generalized to measure any absorbent material in normal and oblique impact site. But some more investigations have to be undertaken to defined resolution and accuracy of the proposed instruments. One has to care during the interpretation of such a measurement base on interpretation by relative comparison on two different echograms.

## 5 Conclusions

In small auditoriums, the method delivers some comprehensive spatio-temporal information of the acoustic paths between the source and the microphone array enabling the qualification of global and local characteristics of the room boundaries. Some experimental results validate the process and highlight its contributions, but also the difficulties of implementation.

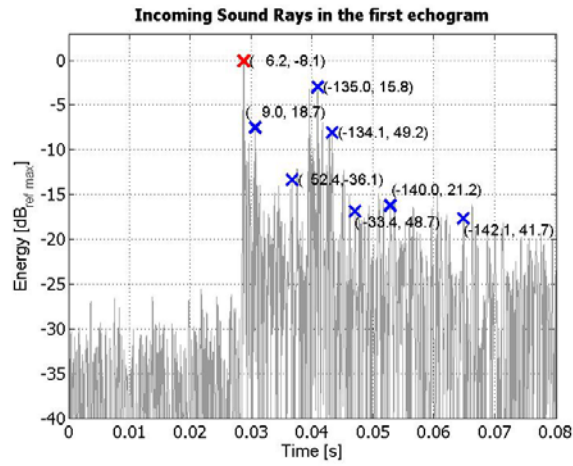

Figure 10: Echogram without curtains - Maison Visinand.

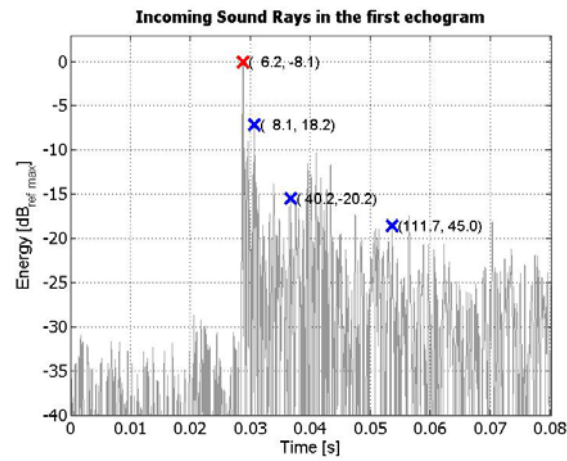

Figure 11: Echogram with curtains - Maison Visinand.

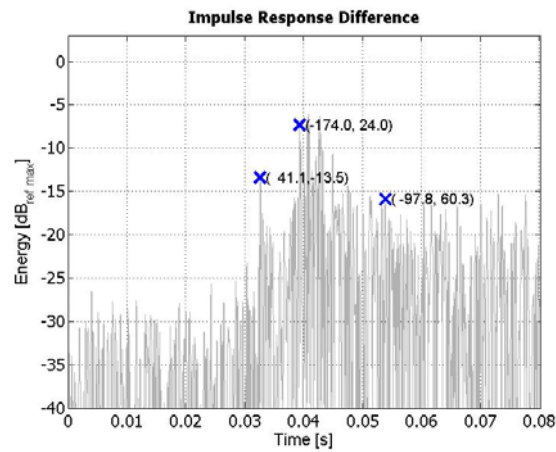

Figure 12: Residual echogram



## 6 Remarks

This work has been undertaken during a master project of four months in the Laboratory of Electromagnetics and Acoustics.

### References

- [1] ISO 3382-1:2009 "Acoustique -- Mesurage des paramètres acoustiques des salles -- Partie 1: Salles de spectacles"
- [2] ISO 3382-1:2008 "Acoustique -- Mesurage des paramètres acoustiques des salles -- Partie 2: Durée de réverbération des salles ordinaires"
- [3] Boulandet, R., "Localisation des premières réflexions dans une salle par chronogoniométrie acoustique", in 10ème Congrès Français d'Acoustique. (2010): Lyon, France.
- [4] Allen, J.B. and Berkley, D.A., "Image method for efficiently simulating small-room acoustics". The Journal of the Acoustical Society of America, 65 (4), p. 943-950, (1979)
- [5] deVries, D. and Hulsebos, E.M., "Auralization of room acoustics by wave field synthesis based on array measurements of impulse responses", in EUSIPCO 2004 XII. European Signal Processing Conference, W. Technische Universität, (2004), Vienna. p. 1377 - 1380.
- [6] Van Lancker, E., "Acoustic goniometry", in LEMA. (2001), EPFL: Lausanne. p. 108.
- [7] Marmaroli, P., "Solutions analytiques de localisation pour le goniomètre cubique", rapport interne, EPFL-LEMA (2009).