

Time-domain distributed sensor with 1 cm spatial resolution based on Brillouin dynamic gratings

Kwang-Yong Song*, Sanghoon Chin, Nikolay Primerov, and Luc Thévenaz

Ecole Polytechnique Fédérale de Lausanne, Institute of Electrical Engineering, 1015 Lausanne, Switzerland.

*Permanent address: Chung-Ang University, 156-756 Seoul, Korea.

songky@cau.ac.kr luc.thevenaz@epfl.ch

ABSTRACT

We propose and experimentally demonstrate the highest-resolution BOTDA system ever reported using Brillouin dynamic grating in a polarization-maintaining fiber (PMF). Acoustic waves containing the information of local Brillouin frequency are generated by a long pump pulse in one polarization, and read out by a short probe pulse in the orthogonal polarization at a clearly distinct optical frequency from the pump. In the experiment, a distributed strain measurement with 1 cm spatial resolution is performed over a 20 m fiber.

KEYWORDS LIST: Optical fiber sensor, Distributed measurement, Stimulated Brillouin scattering, Gratings, Polarization.

1. INTRODUCTION

In recent studies [1-5], the concept of Brillouin dynamic grating (BDG) has been newly implemented in polarization-maintaining fibers (PMF), where acoustic waves generated during the process of stimulated Brillouin scattering (SBS) by optical waves (pump waves) in one polarization are used to reflect an orthogonally-polarized wave (probe wave) at a different optical frequency from the pump. As shown in the conceptual scheme in Fig. 1, the frequency separation Δf between the pump and the probe waves in the BDG operation is determined by the birefringence of the PMF and lies in the several ten's of GHz in usual cases. As a potential application, a novel type of birefringence-based distributed sensor has been proposed using the BDG with an order-of-magnitude higher sensitivity in the temperature measurement compared to ordinary Brillouin sensors [3-5]. In this paper, we propose and experimentally show that the BDG can be applied to enhance the spatial resolution of an ordinary Brillouin optical time-domain analysis (BOTDA) system by replacing the Brillouin probe with the reflection from the BDG. We explain how to acquire a narrowband Brillouin gain spectrum (BGS) with a broadband pulse using the BDG, and demonstrate BOTDA measurements with a 1 cm spatial resolution, which is the best result ever reported using a time-domain Brillouin sensor, as confirmed experimentally.

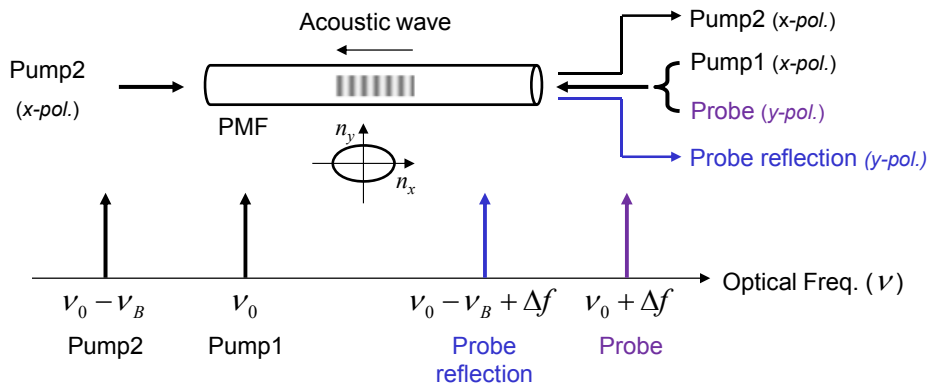

Fig. 1. Description of the concept for the generation and the reading of Brillouin dynamic grating

2. PRINCIPLE

In BOTDA systems the spatial resolution is determined by the duration of the pump pulse. Although improvements have been reported [6-7], the measurement with a very short pulse (< 10 ns) is generally followed by the broadening of the effective BGS as depicted by Fig. 2(a), which degrades the accuracy of the measurement. The origin of the BGS-broadening can be explained by the fact that the broadband pump wave creates a broad Brillouin gain by generating acoustic waves spanning over a wide frequency range, so the shape of the effective BGS - the intrinsic bandwidth of which is about 30 MHz in optical fibers - follows that of the pump spectrum.

Figure 2(b) shows our scheme where the pump waves (Pump 1 and Pump 2) in the x-polarization and a probe pulse in the y-polarization are applied for the generation of the BDG (i.e. acoustic wave) and its readout, respectively. In this scheme, we use a relatively long pulse (30 ns) for pump1 to maintain a narrowband Brillouin gain (also narrowband BDG), meanwhile adopt a ultra-short probe pulse (~ 110 ps) to realize a high-resolution acquisition of the local BGS. When the broadband probe pulse is reflected by the local BDG, the reflectance, which is determined by the spectral overlap between the BDG and the probe pulse, is proportional to the strength of the BDG. It means that the time trace of the probe reflection shows the local strength of the BDG, which depends on the Brillouin gain in the process of SBS between two pump waves. Thus, the shape of the BGS can be retrieved from the probe reflection by sweeping the frequency offset between Pump 1 and Pump 2. Since the spatial resolution of this measurement is determined by the duration of the probe pulse while the bandwidth of the Brillouin gain is related to the duration of Pump 1, a high spatial resolution BOTDA can be achieved while keeping a narrow effective Brillouin gain spectrum. It must be pointed out that the probe frequency is not scanned, since its spectrum covers a much broader spectrum than any reasonable change of the BDG frequency due to environment, as shown in Fig. 2(b).

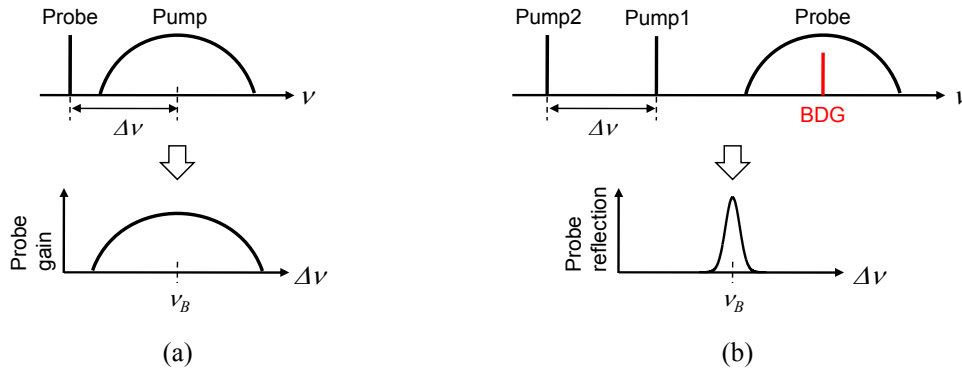

Fig. 2. Acquisition of a local Brillouin gain spectrum (BGS) with a short pulse in (a) standard BOTDA system by way of probe-gain variation, and (b) BDG-based BOTDA system by way of BDG-strength variation.

3. EXPERIMENTS

We carried out a distributed measurement along a 20 m PMF with a spatial resolution of ~ 1 cm. The experimental setup is shown in Fig. 3, where two 1550 nm DFB LDs were used for the pump and the probe waves, respectively. The output from the pump LD was divided by a 50/50 coupler, and Pump 1 was shaped as a 30 ns square pulse at a 1 MHz repetition rate using a pulse generator and an electro-optic modulator (EOM1). Pump 2 was simply a continuous wave (CW) with the optical frequency down-shifted from Pump 1 to lie in the vicinity of ν_B (~ 10.89 GHz) in the PMF using a sideband-generation by another EOM (EOM2) and a microwave generator. Pump 1 and Pump 2 were prepared to counter-propagate along the slow axis (x-pol.) of the PMF using a polarizer (Pol.) and polarization beam splitters (PBS1 & PBS2) after being amplified by Er-doped fiber amplifiers (EDFAs) to 26 dBm and 14 dBm, respectively.

For the readout of the BDG, a 110 ps bell-shaped pulse was prepared as a probe wave using gain switching of the probe LD by direct current modulation using a pulse generator. The probe pulse was amplified by an EDFA and propagated in the same direction as Pump 1 along the fast axis (y-pol.) of the PMF through a polarization-maintaining (PM) circulator, a polarizer and PBS1 while the pump waves were propagated along the slow axis. The launch of the probe was synchronized to Pump 1 pulse so that the time delay between the probe and Pump 1 was set to 30 ns (Pump 1 precedes). In this way, a strong BDG showing a narrow bandwidth was generated at the pumps crossing point and was always well-positioned to reflect the probe pulse along the fiber. The timing and the shapes of the pulses are depicted in

Fig. 4(a) which were measured by PD2 in Fig. 3. The reflected signal from the BDG was extracted using a PM circulator and a tunable grating filter, and pre-amplified by another EDFA prior to the detection by a 12 GHz photo diode (PD1) and a fast data acquisition (DAQ). Figure 4(b) shows the optical spectrum measured in front of PD1 by an optical spectrum analyzer, where a strong reflection from the BDG is clearly observed with a frequency offset Δf of 44 GHz.

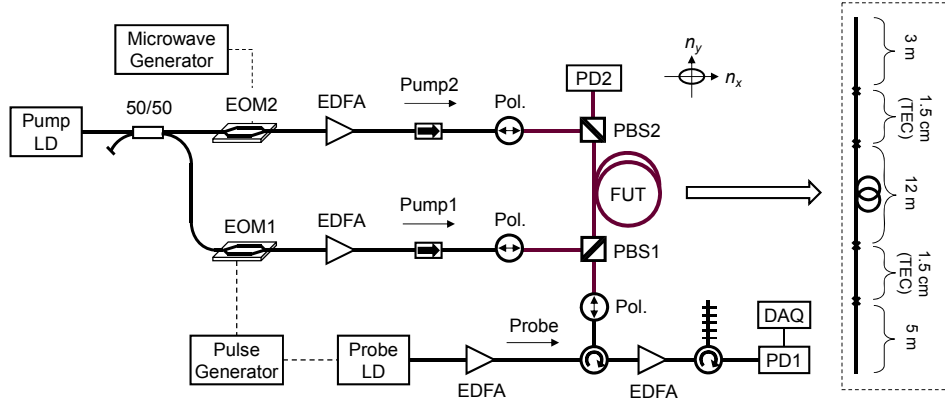

Fig. 3. Experimental setup: LD, laser diode; EDFA, Er-doped fiber amplifier; PBS, polarization beam splitter; Pol., fiber polarizer; EOM, electro-optic modulator; FUT, fiber under test; TEC, thermo-electric controller. The inset shows the structure of the FUT where two 1.5 cm sections were temperature-controlled by TECs.

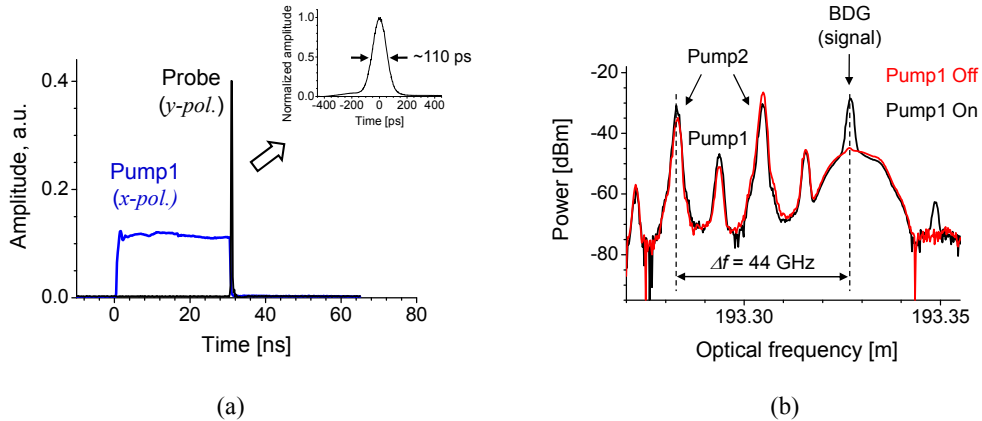

Fig. 4. (a) Timing and shape of Pump 1 and probe pulses. (b) Optical spectra measured in front of PD2 with Pump 1 on (black) and off (red).

The structure of the fiber under test (FUT) is shown in the inset of Fig. 3, where two 1.5 cm sections within a 20 m PMF were temperature-controlled by a TEC. We applied temperature variations of about -5, +25, +50 K, and performed distributed measurements by collecting the BDG reflection signal using PD2 while sweeping the frequency offset $\Delta\nu$ between Pump 1 and Pump 2 from 10.77 to 10.92 GHz. The data were averaged 30 times and the accuracy on the measured $\Delta\nu_B$ was typically ± 1 MHz.

The measurement results are shown in Fig. 5 where the distribution of the ν_B along the fiber is presented, showing clear shifts of ν_B at the positions of the TEC (center). The zoomed views of the temperature-controlled sections are depicted at both sides of Fig. 5, where the shifts of ν_B at the 1.5 cm sections were clearly detected, confirming the high resolution (~ 1 cm) of our scheme. Note that the discreteness of the data points is due to the limited sampling rate of the DAQ (~ 2 pts/cm).

The local BGS in one of the TEC sections (near position 14.7 m) is depicted in Fig. 6(a). It is observed that the central frequency of the BGS is clearly shifted while the temperature is incremented without apparent broadening of its spectrum, the width (FWHM) of which is remarkably maintained around 40 ~ 50 MHz. Figure 6(b) shows the 3-D plot of Brillouin gain spectra near a TEC section with $\Delta T = +50$ K, where the local shift of the gain peak is clearly observed.

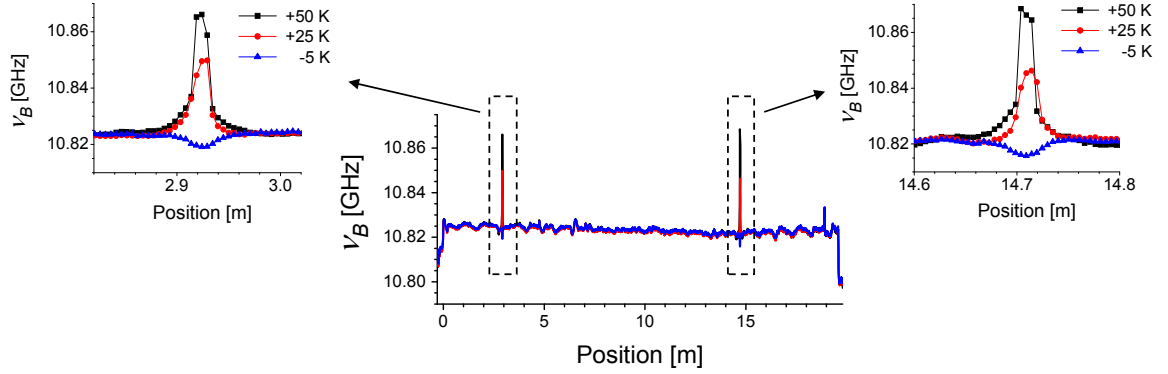

Fig. 5. Distribution of the Brillouin shift ν_B along the fiber subject to 1.5 cm short temperature controlled sections acquired by the BDG-based BOTDA system (center) with the zoomed views of the dashed boxes (sides).

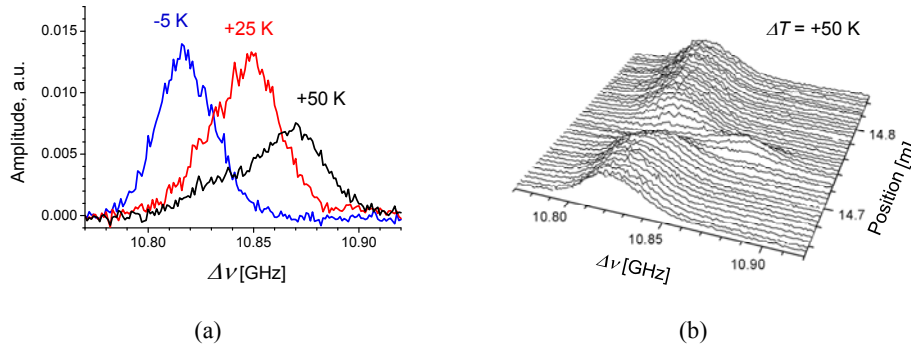

Fig. 6. (a) Local BGS at one of the temperature-controlled sections for different temperature variations. (b) 3-D plot of distributed Brillouin gain spectra near the temperature-controlled section with $\Delta T = +50$ K.

4. CONCLUSION

We have proposed and demonstrated a high resolution BOTDA system based on the BDG in a PMF, where the local BDG is exploited to reflect the probe waves. To the best of our knowledge, 1 cm spatial resolution was for the first time realized in a pulse-based Brillouin sensor. This result is certainly not the ultimate limit since there is no fundamental obstacle to achieve a higher resolution using a shorter probe pulse.

REFERENCES

- [1] K. Y. Song, W. Zou, Z. He, and K. Hotate, "All-optical dynamic grating generation based on Brillouin scattering in polarization maintaining fiber," *Opt. Lett.* **33**, 926-928 (2008).
- [2] V. P. Kalosha, W. Li, F. Wang, L. Chen, and X. Bao, "Frequency-shifted light storage via stimulated Brillouin scattering in optical fibers," *Opt. Lett.* **33**, 2848-2850 (2008).
- [3] W. Zou, Z. He, K. Y. Song, and K. Hotate, "Correlation-based distributed measurement of a dynamic grating spectrum generated in stimulated Brillouin scattering in a polarization-maintaining optical fiber," *Opt. Lett.* **34**, 1126-1128 (2009).
- [4] K. Y. Song, W. Zou, Z. He, and K. Hotate, "Optical time-domain measurement of Brillouin dynamic grating spectrum in a polarization maintaining fiber," *Opt. Lett.* **34**, 1381-1383 (2009).
- [5] Y. Dong, X. Bao, and L. Chen, "Distributed temperature sensing based on birefringence effect on transient Brillouin grating in a polarization-maintaining photonic crystal fiber," *Opt. Lett.* **34**, 2590-2592 (2009).
- [6] V. P. Kalosha, E. A. Ponomarev, L. Chen, and X. Bao, "How to obtain high spectral resolution of SBS-based distributed sensing by using nanosecond pulses," *Opt. Express* **14**, 2071-2078 (2006).
- [7] W. Li, X. Bao, Y. Li, and L. Chen, "Differential pulse-width pair BOTDA for high spatial resolution sensing," *Opt. Express* **16**, 21616-21625 (2008).