

Thick-film multi-DOF force / torque sensor for wrist rehabilitation

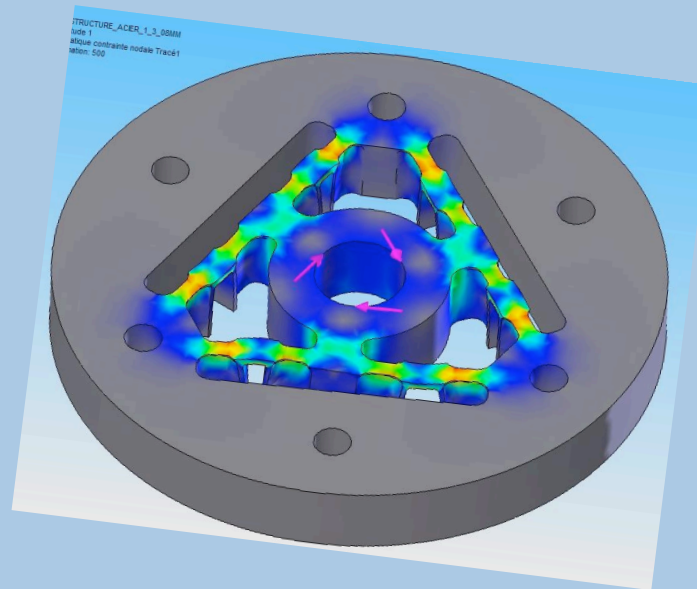

B. Lüthi, Dr T. Maeder, C. Jacq, Prof P.Ryser
Laboratoire de Production Microtechnique, EPFL
Caroline.jacq@epfl.ch <http://lpm.epfl.ch>

Aim of this study

Wrist rehabilitation:



- To increase muscle strength
- To reduce abnormal muscle synergies



Force / Torque Sensor

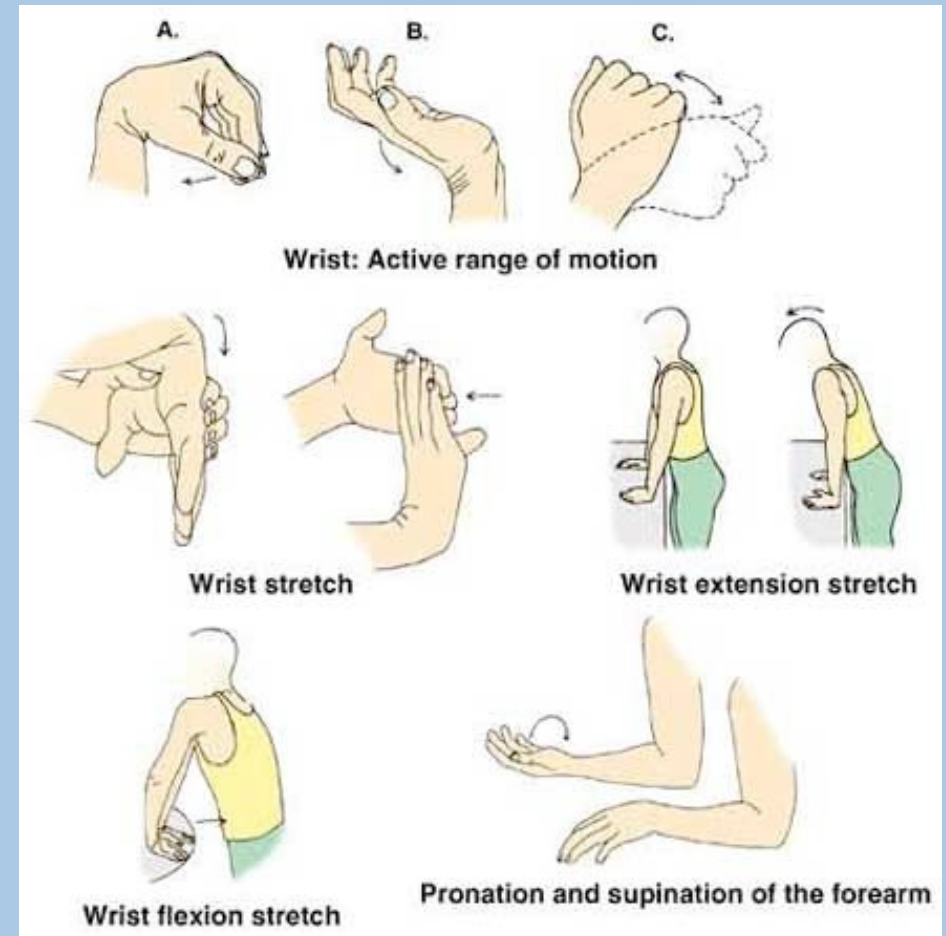

Force / Torque Sensor



→ Sensor compatible with 3-axis milling

→ Thick-film technology on steel = rugged and low cost

→ Specifications

- Force x, y: 100 N
- Force z : 200 N
- Moment z: 5 Nm

Mechanical concept

3 forces + 3 torques



3 modules in a triangular configuration

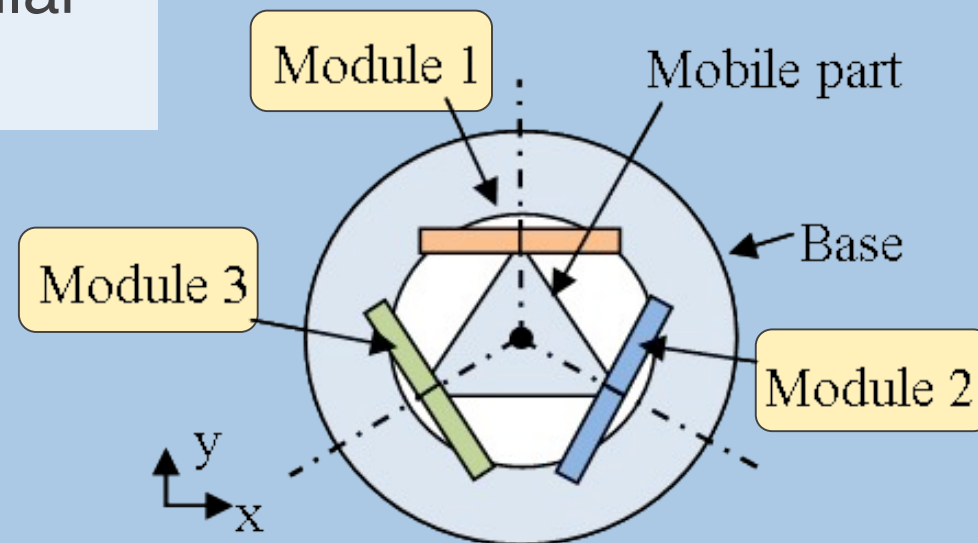

Mechanical concept

Section of module

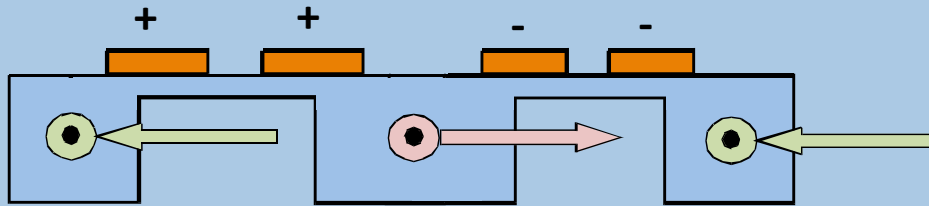

Module working in tension/compression

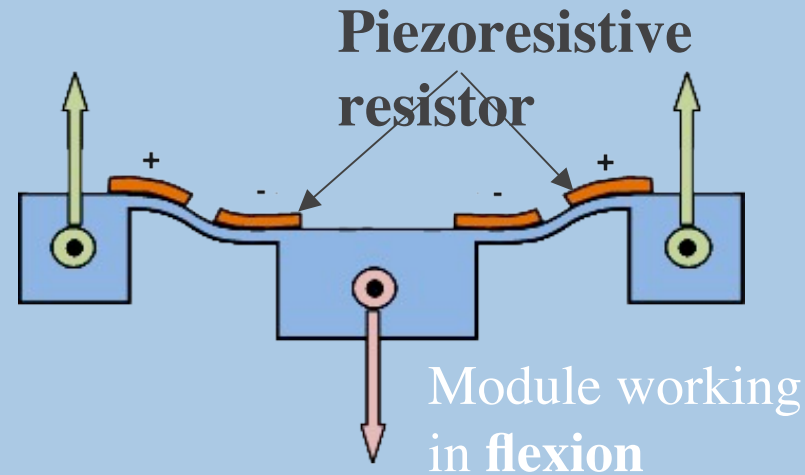

Module working in flexion

Each Wheatstone bridge

↓
2 forces:

- Tension/compression force
- Vertical force

X 3 → 6 DOF

Dimensioning of the sensor

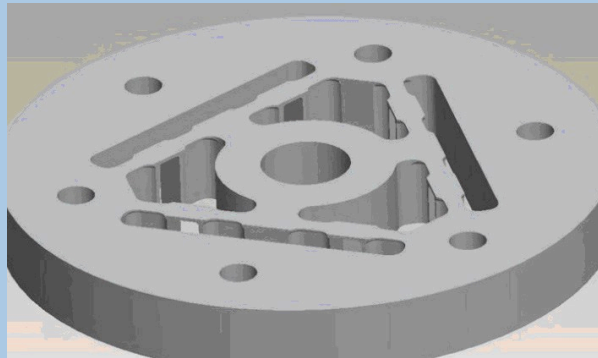

Top view

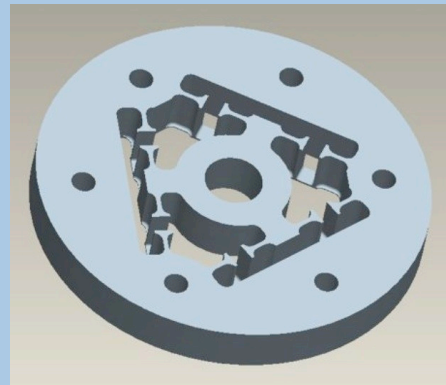

Bottom view

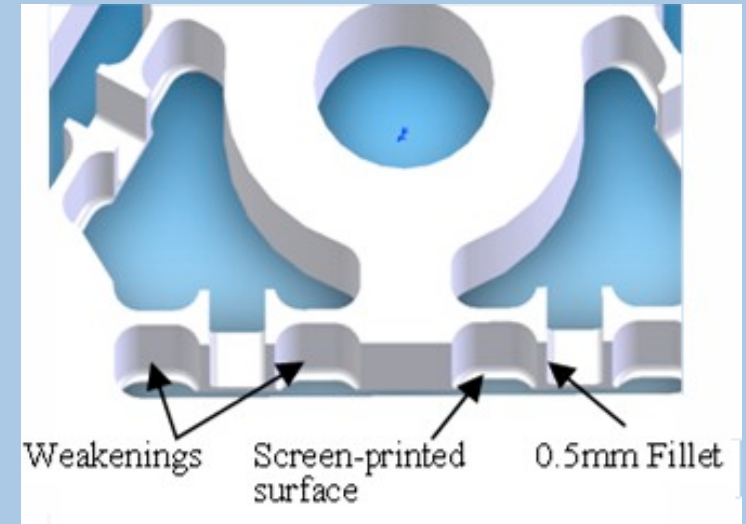

Zoom of the bottom view on the weakened zones

Axis	Nominal	Design	
F_z	200	200	[N]
F_x, F_y	100	1'000	[N]
M_z	5	20	[N·m]
M_x, M_y	(not specified)	3	[N·m]

3D-Modelling

FEM analysis (Von Mises stress)

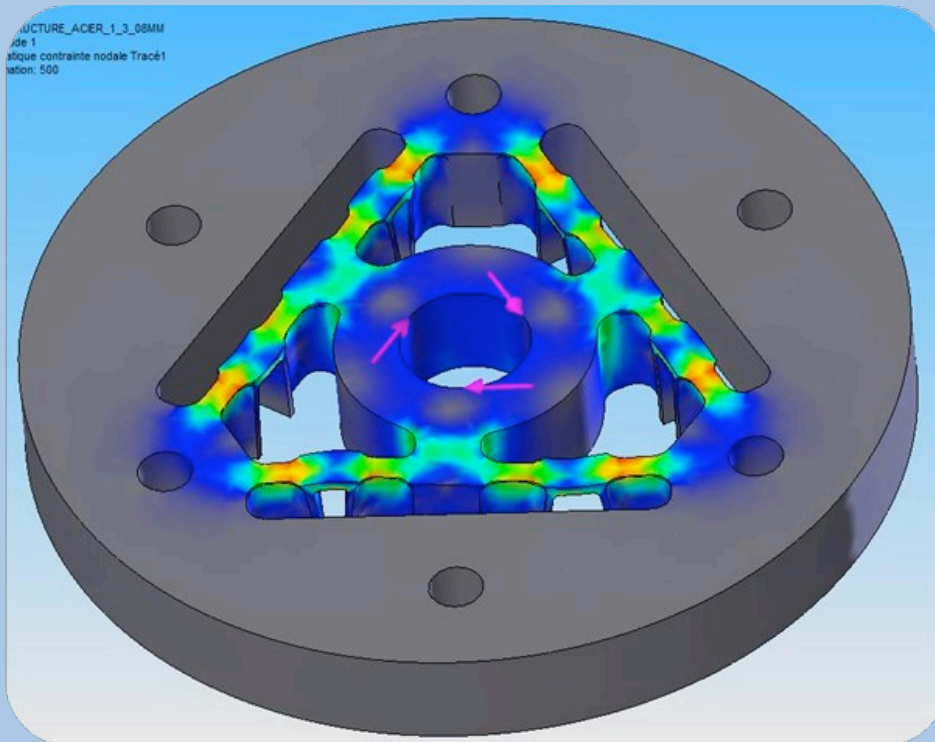

5 N · m M_z torque

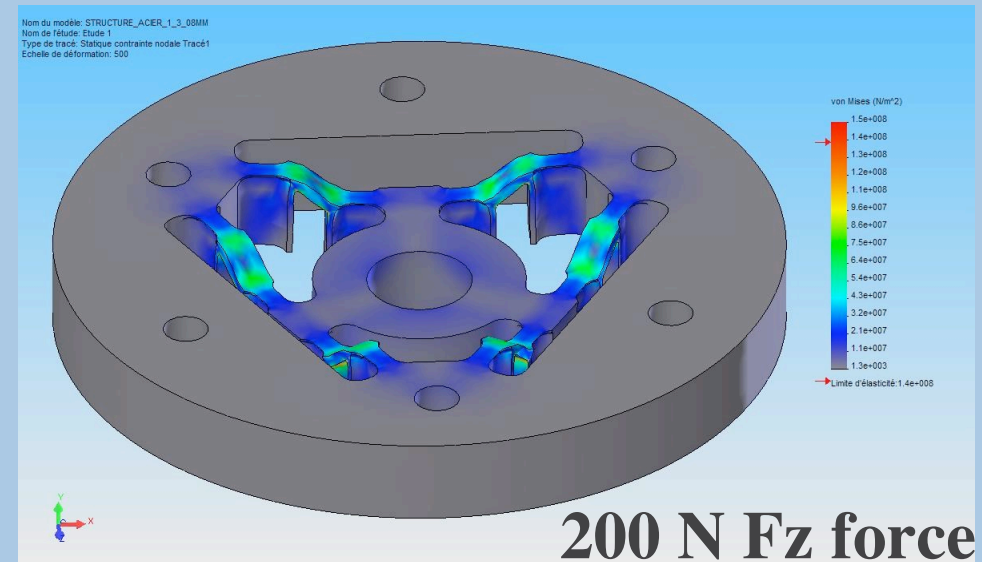

Manufacture: Thick-film process

850°C

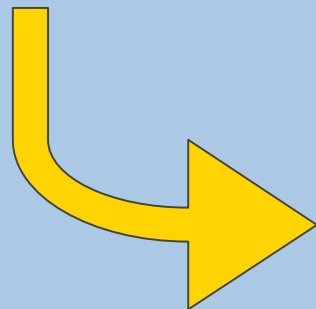
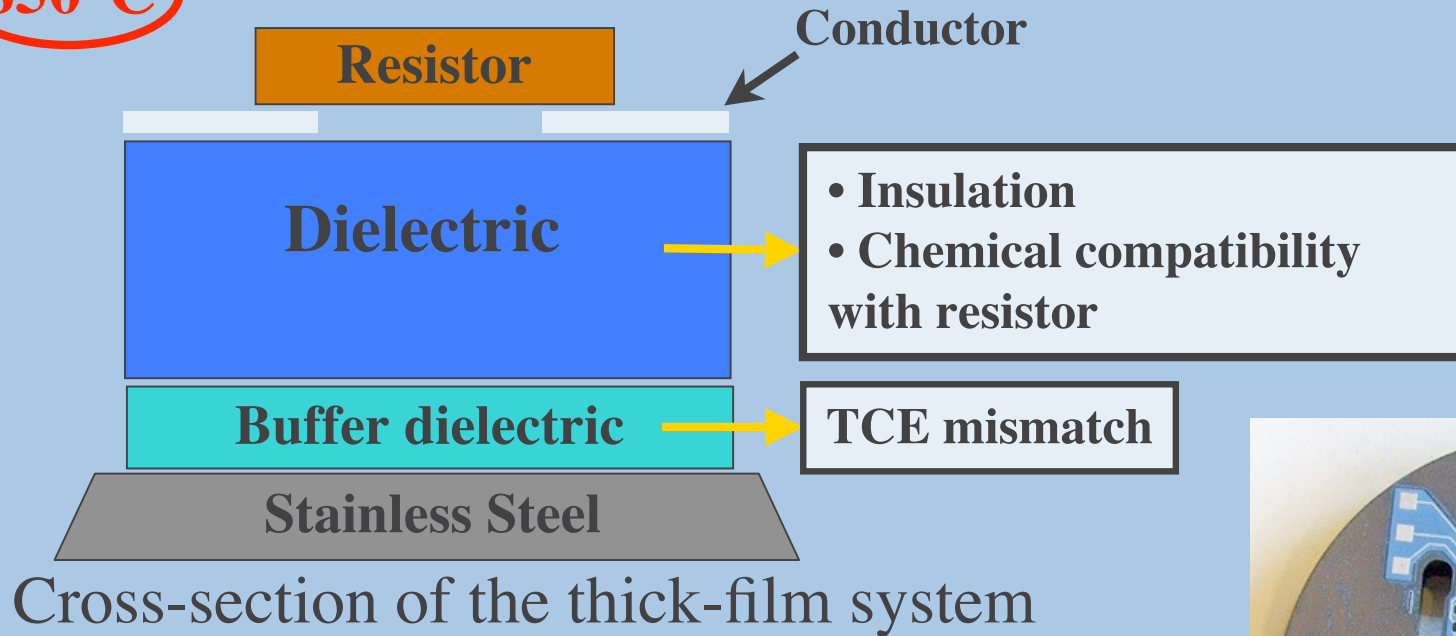

6 DOF sensor

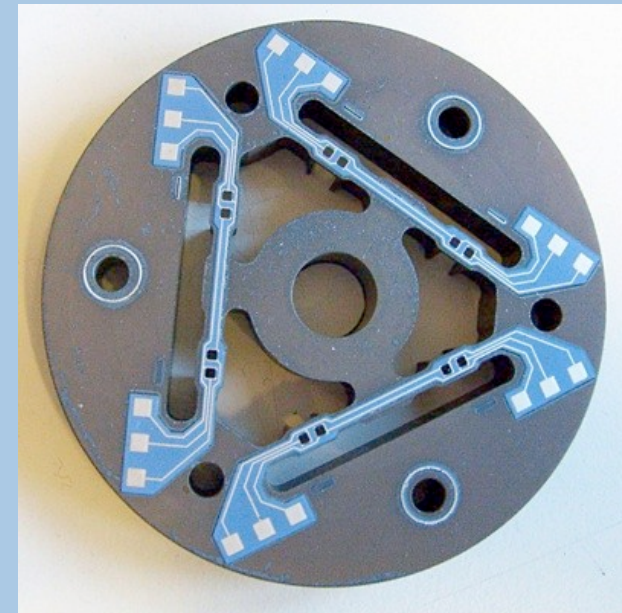

Characterisation

- Set up of characterisation

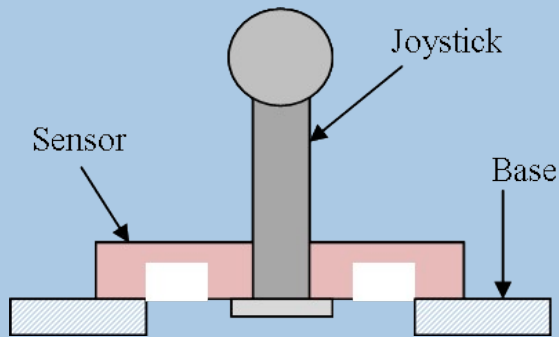

Precision:

- F_x, F_y, F_z : 3-4 %
- M_z : 5-10 %

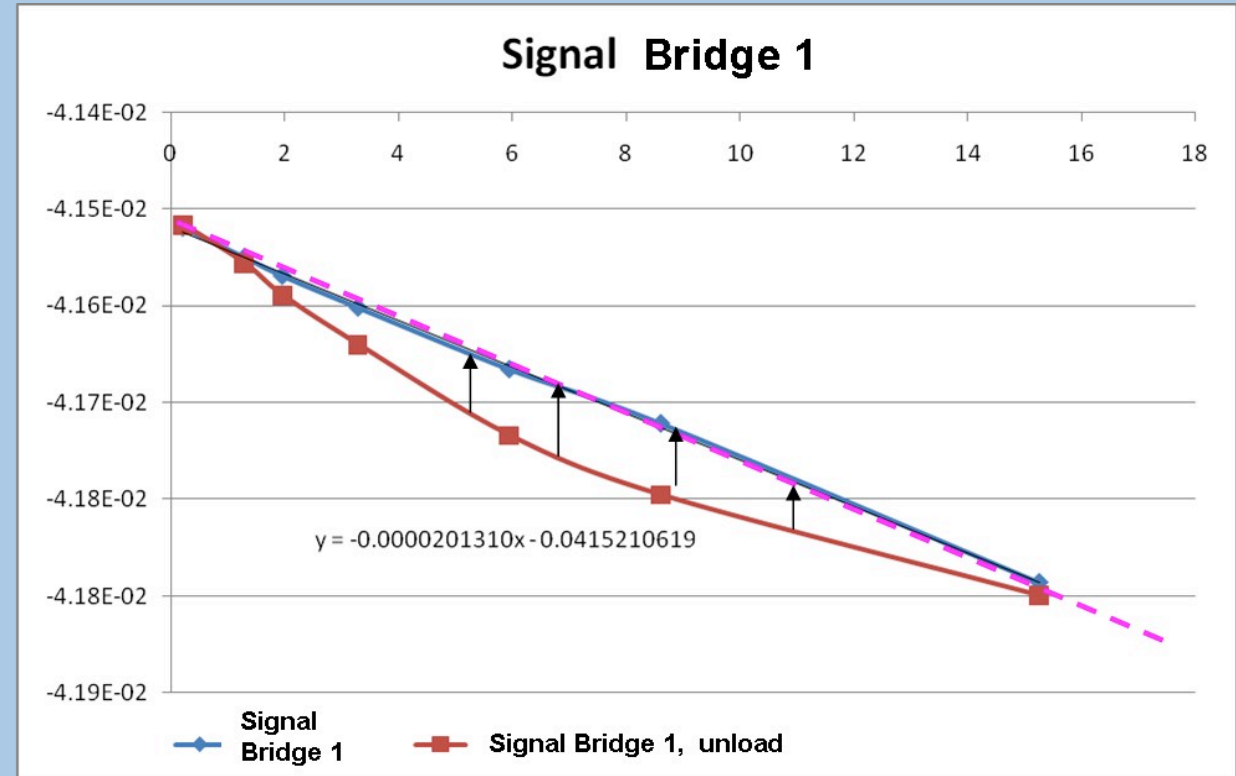

- Result for M_z torque

Conclusion & Outlook



- 6 DOF force / torque sensor
- Lead-free, low-firing TF system
- High strength martensitic steel
- Aluminium alloys

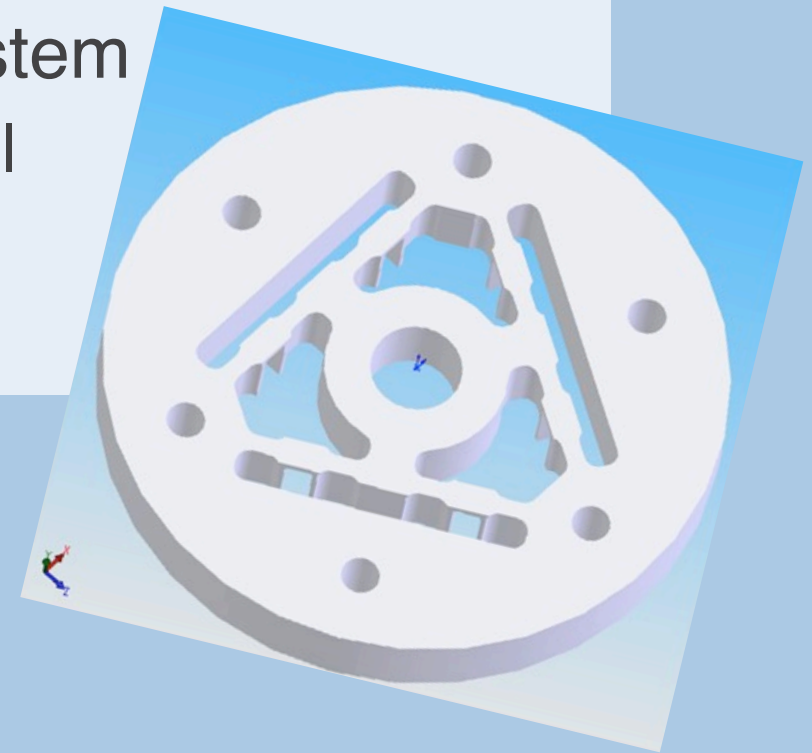

Thick-film multi-DOF force / torque sensor for wrist rehabilitation



Thank you for
your attention!