

Expected benefits of adjustable speed pumped storage in the European network

Prof. Jean-Jacques Simond, Dr. Alain Sapin

Electrical Engineering Department
Swiss Federal Institute of Technology
EPFL-DE-LEME
1015 Lausanne

Daniel Schafer

R&D Manager
ABB Power Generation Ltd.
(ABB-Alstom-Power Company)
5242 Birr

Switzerland

Summary

In the context of a sustainable development the optimal use of the electrical energy will require advanced networks allowing interconnections on very long distances and addressing the storage challenge. These requirements are essentially due to the following reasons:

- Electrical energy, contrary to most other kind of energies, must be simultaneously produced and consumed, because it is not possible to store directly large amounts of it.
- Electrical energy is generated to a large extent by thermal power plants or by run-of-river stations operating as base load units at nearby constant power.

Therefore it is not possible to cover a power demand strongly variable in space and time, without non electrical wide auxiliary storage capacities and also without network interconnections on very long distances.

A comparative assessment of existing storage systems shows that, with an overall efficiency of more than 85%, the conventional pumped storage systems are the most adequate solution for large scale electrical storage in off-peak demand periods. However, the efficiency and the operation flexibility of these conventional pumped storage running at constant speed can be noticeably increased by using variable speed groups.

This modern variable speed technology require an electronic power conversion system, a high performance control equipment and a special design of the motor-generator and of the pump-turbine. Among the different possible solutions, the system with a doubly fed wound rotor asynchronous machine (DASM-solution) fed on the rotor side either by cycloconverter or by a GTO-converter offers the best electrical and hydraulic performances in terms of: active power control in pumping mode with optimal efficiency – reactive power control at the grid interconnection point – fast response of active power (flywheel effect, frequency control) – no supplementary need of pump starting up equipment – improvement of the hydraulic efficiency – extended partial load operating range and head operating range in generation mode.

The main objective of this contribution is to illustrate the benefits which can be expected in terms of network performances and stability by using adjustable speed pumped storage schemes. These benefits have to be considered and evaluated when comparing the respective investment cost of a conventional or of an adjustable speed pumped storage group.

1. Large adjustable speed motor-generators

In comparison with a conventional motor-generator operating at constant speed, an adjustable speed pumped storage group has not only the advantage of an increased overall efficiency, it offers also the following benefits for the electrical network :

- Possibility of active power control in pumping mode.

- Possibility of reactive power control at the interconnection point.
- Possibility of instantaneous active power injection into the grid by reduction of the speed set value and using the kinetic energy stored in the rotating mass.

These possibilities lead to a very appreciable improvement of the network quality in terms of performances and stability. Basically, a large adjustable speed motor-generator can be realized by using either a synchronous machine with a static frequency converter connected between the stator and the grid [1], or a doubly fed asynchronous machine (DASM) with a cycloconverter or a GTO converter in its rotor circuit [2,3,4] according to Figure 1. The solution using a synchronous machine is not economically attractive for large units (> 250 MVA) because the static frequency converter has to be sized for the rated power. The maximum unit power output with a DASM is about 500 MVA for a speed range of $\pm 10\%$ of the synchronous speed, which corresponds to a power variation of $\pm 30\%$. Those speed and power ranges allow the utility to pump and to generate with partial load but with optimum efficiency.

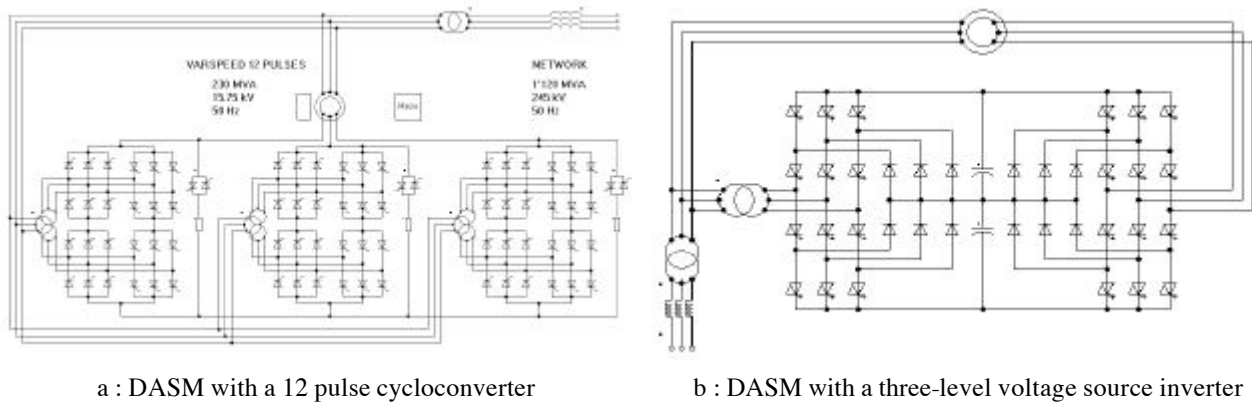

Figure 1 : DASM pumped storage groups

In the following, this contribution will focus on the DASM by illustrating the benefits obtained for the electrical network in terms of performances and stability. The constructive aspects of a DSAM are not presented here, they are described in [5,6].

2. Contributions of an adjustable speed pumped storage DASM group to the network performances and stability

The following numerical simulations illustrate the possibilities offered by an adjustable speed pumped storage group of DASM type (with a 12 pulse cycloconverter in the rotor circuit according to fig. 1a), whose rated values are :

- Rated apparent power :	230	MVA
- Rated voltage :	15,75	KV
- Synchronous speed :	333,3	rpm
- Speed range :	300 – 366	rpm
- Frequency :	50	Hz
- Inertia :	1120	tm ²
- Grid voltage :	15,75	KV
- Grid short circuit power :	1120	MVA

The numerical simulations have been carried out with the simulation program SIMSEN developed at the Swiss Federal Institute of Technology in Lausanne. This program is in use with success at different ABB companies since many years, a brief description of it is given in the appendix of this paper or at : <http://simсен.epfl.ch>

2.1. Steady state operation

A motor-generator of DASM type can operate in the four quadrants of a P-Q diagram within a given speed range around the synchronous speed. The limits of the operating power and speed ranges are given by the maximum apparent stator power and by the maximum cycloconverter output. The different active power flows are schematically represented in Figure 2 for motor and generator operation at sub- and supersynchronous speed.

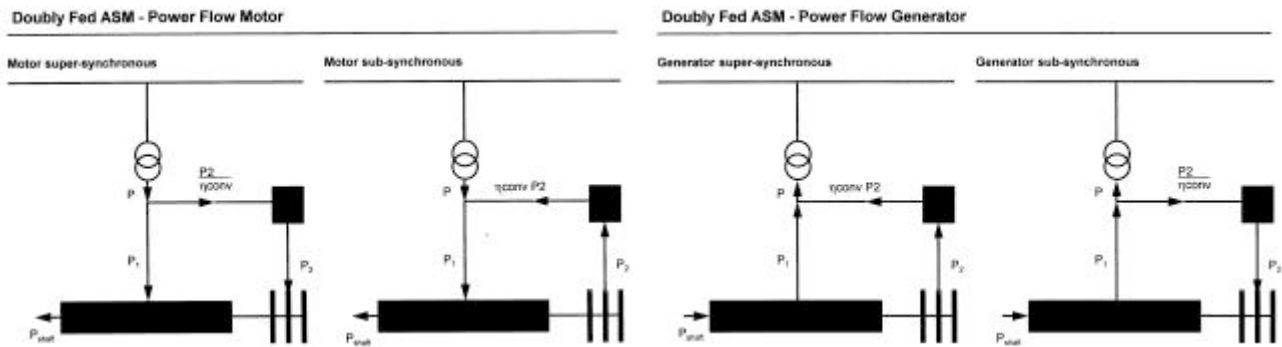

Figure 2 : power flows

Figure 3 illustrates a steady state operation at partial load in generation mode with a turbine torque of 0,95 p.u., a speed of 0,95 p.u. and a stator reactive power equal to zero. According to Figure 2, the stator active power is 0,95 p.u. and the transformer active power is 0,90 p.u. On the grid side we can see a very low harmonics content in the current and voltage curves even without using filters. All quantities are given in p.u. in the motor-generator reference system (230 MVA ; 15,75 KV ; 333,33 rpm).

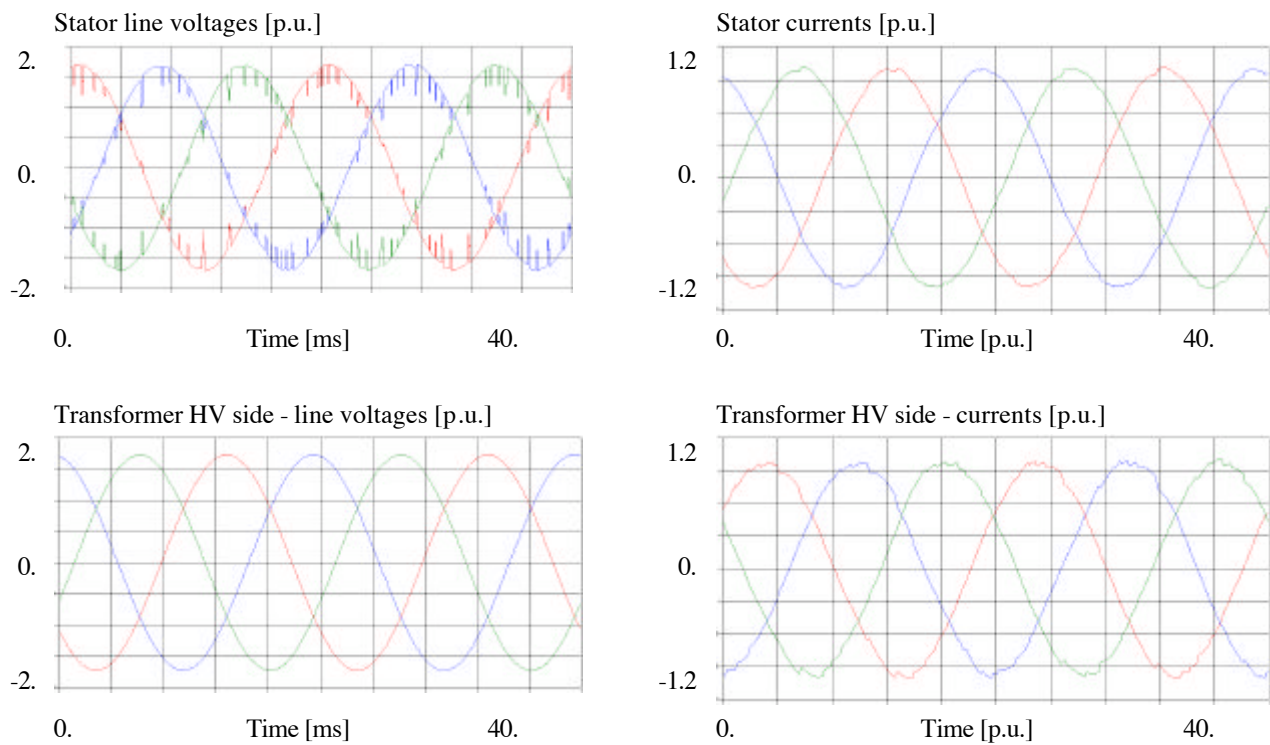

Figure 3 : steady state operation

2.2. Reactive power control at the interconnection point

This first example of a transient behaviour concerns two successive modifications of the stator reactive power set value under rated voltage. The initial conditions correspond to the operating point of Figure 3. The stator reactive power set value is then changed from zero to + 0,2 p.u. (i.e. + 46 MVar) and 600 ms later to - 0,2 p.u. (i.e. - 46 MVar). The simulation results in Figure 4 show that a DASM motor-generator is able to absorb or to produce large amounts of

reactive power within a very short response time. *This performance is absolutely comparable to a static voltage compensator of Statcon type.*

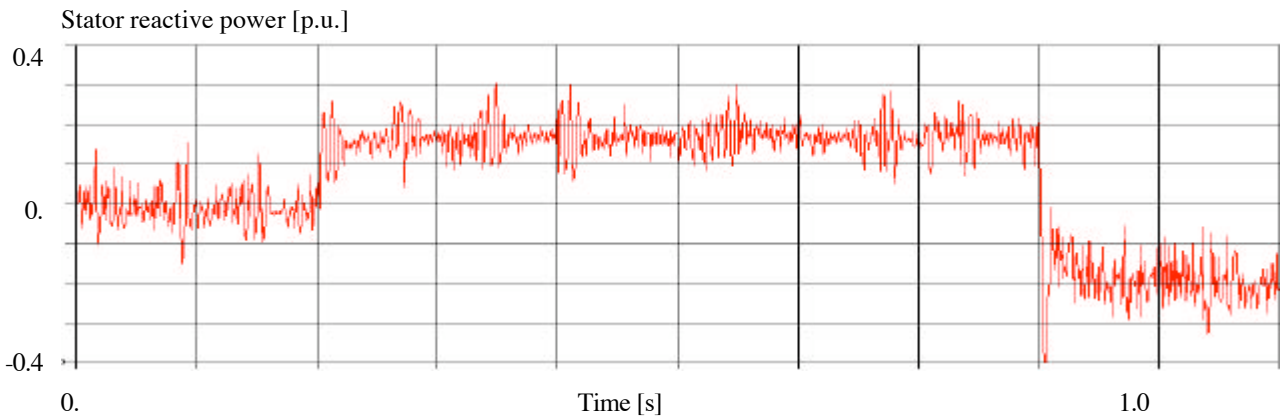

Figure 4 : reactive power control

2.3. Instantaneous active power injection

The initial conditions for this second example correspond also to the operating point of Figure 3. The speed set value is then decreased from 0,95 p.u. to 0,90 p.u. and a part of the kinetic energy is instantaneously extracted and injected into the grid as represented in Figure 5. After this operation the machine stabilizes at the new steady state speed of 0,90 p.u. The amount of energy injected into the grid depends of course also on the inertia of the group, the maximum power is depending on the limitation value chosen for the stator current during the injection (in this case 1,15 p.u.). *In this simulated example, it is possible to inject about 20 MW more into the grid during 4 s.*

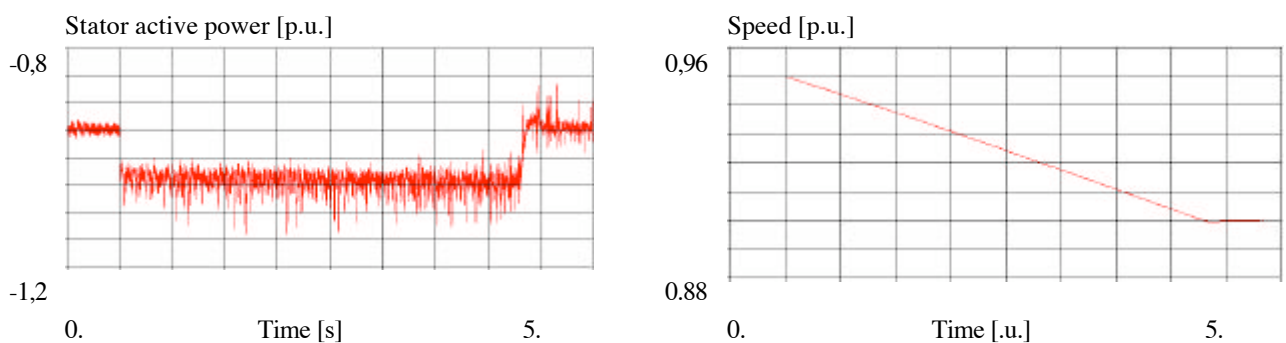

Figure 5 : instantaneous active power injection

2.4. Voltage dip during 100 ms on the grid side

In case of a voltage dip of 50 % occurring during 100 ms on the HV side of the transformer, Figure 6 shows that the DASM motor-generator stabilizes very quickly after the voltage drop. *Therefore the grid is not disturbed by a strong oscillation of the machine as it would be the case during a few seconds with a classical synchronous machine.*

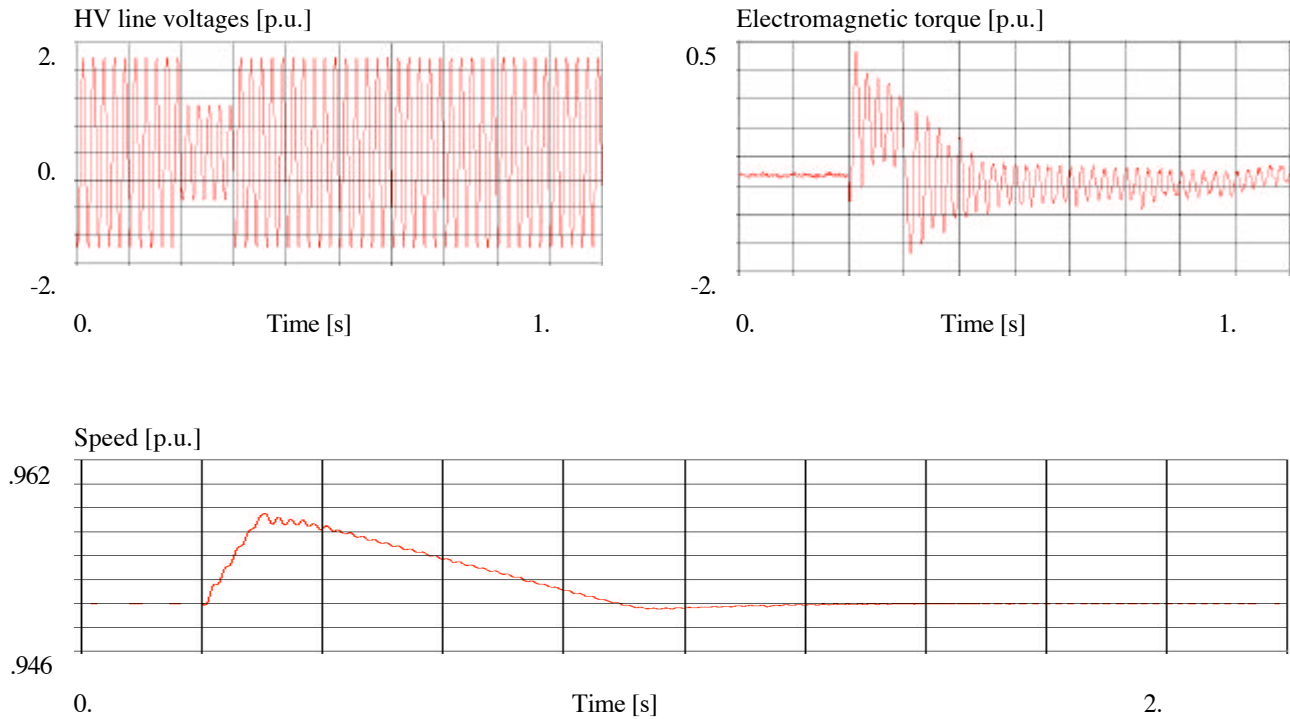

Figure 6 : voltage dip

3. Conclusions

The behaviour of a 230 MVA DASM pumped storage group has been simulated in steady state as well in transient operation. The results of the different simulations illustrate the benefits for the grid stability obtained by this modern adjustable speed technology in comparison with a conventional synchronous motor-generator operating at constant speed. These benefits could be increased in terms of dynamic performances by using a multi-level GTO-converter instead of a cycloconverter in the rotor circuit of the DASM.

In comparison with a conventional constant speed unit, the supplementary investment needed for an adjustable speed pumped storage group must be evaluated by taking into account the above mentioned benefits.

References

1. L. Terens, R. Schäfer: Variable speed in hydro power generation utilizing static frequency converters, Nashville Tennessee, Waterpower 93.
2. J. M. Merino, A. Lopez: ABB Varspeed generator boosts efficiency and operating flexibility of hydropower plant, ABB Review 3/1996, p. 33-38.
3. T. Yanagisawa, T. Kageyama, K. Okamura, K. Kusunoki, T. Taguchi, M. Abe, H. Kaneko: Transient Analysis of a Converter-Fed Adjustable Speed Generator-Motor for the Pumped Storage Power Plant, Electrical Engineering in Japan, Vol 116. No. 2 1996, p. 63-76.
4. E. Kita, A. Bando, T. Kuwabara: 400 MW Adjustable-Speed Pumped Storage Hydraulic Power Plant, Hitachi Review Vol. 44 (1995), No. 1, p.55-62.
5. D. Schafer, J. J. Simond: Advantages for the electric grid using a doubly fed asynchronous machine – Numerical simulations, Hydropower into the next century, Portoroz, Slovenia, September 97.

6. D. Schafer, J.-J. Simond : Adjustable Speed asynchronous Machine in Hydro Power Plants and its Advantages for the Electric Grid Stability, CIGRE report, Paris 1998.
7. J. J. Simond, A. Sapin, B. Kawkabani, D. Schafer, M. Tu Xuan, B. Willy: Optimized Design of Variable Speed Drives based on Numerical Simulation, EPE Trondheim, 1997.

Appendix : SIMSEN general presentation

***SIMSEN*: General presentation**

A modular software package for the numerical simulation and analysis of power networks and adjustable speed drives

SIMSEN has been developed at the Laboratory of Electromechanics and Electrical Machines of the Swiss Federal Institute of Technology in Lausanne. It is designed to provide not only excellent performance, but also to offer a maximum of comfort to the user.

Main features of *SIMSEN*:

- The program runs on PC with Windows NT.
- It is based on a modular structure that enables the numerical simulation of the behavior in transient or steady-state conditions of power networks or adjustable speed drives with arbitrary topology.
- The user builds a network or system directly on screen by choosing, connecting and setting the parameters of the required elements.
- The list of available units includes not only classical components of electrical networks (machines, transformers, lines, loads, circuit-breakers, aso), but also components with semiconductors (rectifiers, converters, aso) as well as regulators, transfer functions, mathematical functions, logical tables and digital devices.
- Each unit implements a specific element based on the differential equations derived from the units model.
- Once the user is over with the building and setup of the structure, an algorithm generates automatically the main set of differential equations for the whole system.
- A transient mode of operation may include several simultaneous or successive disturbances. The numerical integration works with a variable step size, it is therefore possible to detect exactly all the events in time (for example: disturbances or state changes of the semiconductors).
- The open structure of *SIMSEN* allows newly developed units to be easily implemented. An existing unit can also be readily modified. It is thus possible to further widen the application field.
- The available memory on the microcomputer is the only constraint restricting the size of the power network or system to simulate. Dynamic use of the memory allows simulation of large networks or power systems.
- A graphical output permits the visualization of the results and the harmonics analysis.

SIMSEN: List of available units

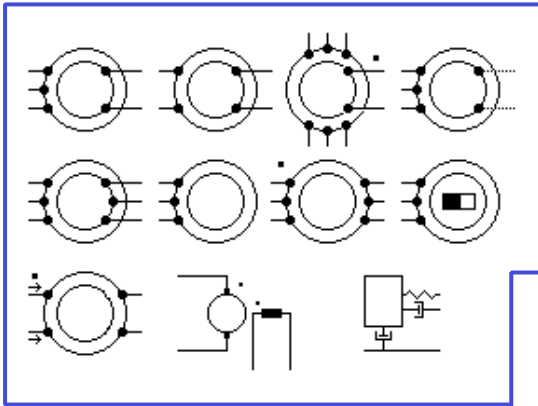

Electrical machines

Three-phase synchronous, single-phase synchronous, 6-phase synchronous, three-phase generalized, three-phase induction with wound rotor, three-phase induction with squirrel cage rotor, two-phase induction, three-phase permanent magnet, DC motor, mechanical mass

Three-phase elements

Voltage supply, transmission lines, circuit breaker, phase shifting transformer, transformer with three windings, load

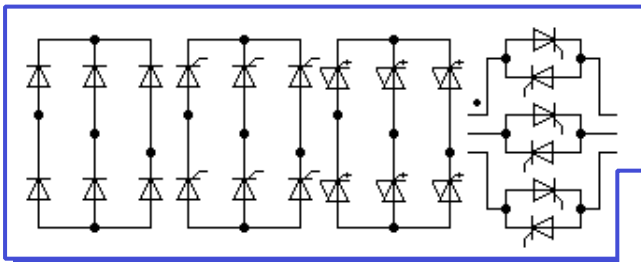
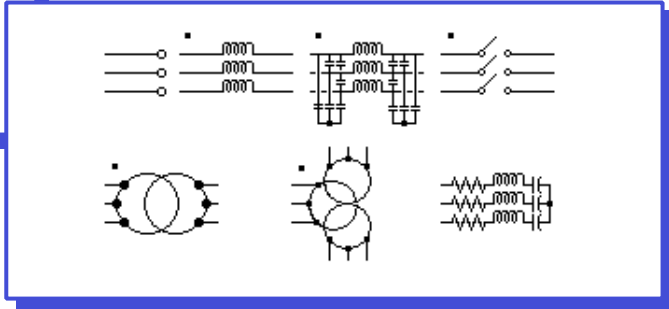

Three-phase converters

Rectifier (diode), current converter (thyristor), voltage inverter (thyristor GTO), current variator (thyristor)

Semiconductors

Diode, thyristor, thyristor GTO, thyristor GTO + diode, triac

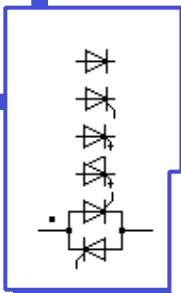

Single-phase elements

Voltage supply, R-L-C, varistor, circuit breaker, linked inductor, transformer

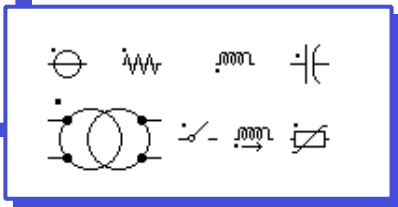

Analog function units

Equation, S-transfer function, regulator, logical table

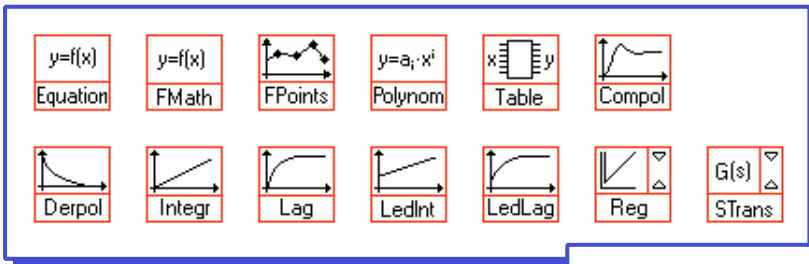

Digital function units

Averager, sample, limiter, pulse generator, Z-transfer function

