

Optical fibre sensing of strain in synthetic fibre tension members: recent results

D Uttamchandani^{**}, A Sass, B Culshaw

Dept of Electronic and Electrical Engineering, University of Strathclyde, Glasgow, UK

M S Overington, M Parsey

Tension Technology International Ltd, Arbroath, Scotland, UK

M Facchini, L Thévenaz

EPFL, Lausanne, Switzerland

*** corresponding author*

ABSTRACT

Strain measurements on synthetic fibre rope constructions of the type used in marine applications are reported. The ropes are of a novel construction by virtue of incorporation of fibre-optic sensors for strain measurement. Two instrumentation approaches - a Brillouin strain measuring system and a RF sub-carrier strain measuring system - have been utilised to interrogate the fibre sensors.

1. INTRODUCTION

Load bearing structures such as ropes and cables used in marine, civil and structural engineering applications are increasingly being manufactured from fibres made from synthetic materials. During their use, such ropes are subject to high strains which can lead to internal damage, for example through breakage of individual rope fibres. This may compromise the designed load bearing capacity of the rope. Detection of such damage is important, but has proven to be difficult and unreliable, even during laboratory testing of such ropes. We have initiated a project concerned with developing a "smart" rope with in-built sensors for measuring the strain distribution in the rope. Abnormal strain readings from the sensors would be indicative of possible damage to the rope compromising its load bearing capacity. The key requirement of a "smart" rope is the ability to measure the strain distribution along its entire working length. This requirement can be met by the integration of a distributed fibre optic sensor array within the structure. Fibre optic strain sensors are suitable candidates for integration into load bearing ropes in view of:

- (a) their electrical passivity at the sensing point
- (b) their high sensitivity to strain
- (c) their long gauge lengths
- (d) their ability to be incorporated into quasi- and fully-distributed sensor systems

The aim of the work reported here has been to determine the technical feasibility of using long gauge length optical fibre sensors for measuring strain along load bearing members, specifically synthetic fibre ropes, with a view to detecting local modulus changes. The approach investigated has involved the incorporation of optical fibres strain sensors into samples of rope, which were subsequently subjected to tensile loading. The fibre sensors

were interrogated using two different types of optoelectronic measuring systems. These were a Brillouin distributed strain measuring system [1] and a pulsed RF sub-carrier modulation quasi-distributed strain measuring system [2].

The University of Strathclyde has been responsible for assembling the RF sub-carrier based quasi-distributed strain measuring system. In partnership with TTL Ltd, the system has been evaluated on polyester parallel strand ropes incorporating a fibre optic sensor. EPFL has developed a fully distributed and portable strain measuring system based on Brillouin gain in optical fibres. In collaboration with Strathclyde and TTI Ltd, the Brillouin system has been evaluated on parallel yarn Kevlar ropes. Preliminary results obtained from the experimental work are reported.

2. RF SUB-CARRIER SYSTEM

Figure 1 shows the basic experimental setup used for multiplexing two optical fibre sensors. It involves gating and scanning over a range of sub-carrier frequencies. In order to measure length and length changes of a single optical fibre sensor, we detect the frequencies of two successive zeros which appear in the response of a sub-carrier interferometer of which the fibre-optic sensor is one arm. The difference between the frequencies of two successive zeros (first and second null frequencies) provide the initial calibration. The values of the null frequencies can then be used to accurately measure the length of the single sensor. Thus, an RF source with frequency tunability is required in the system, but the frequency excursions are quite narrow.

The same approach can be implemented for demultiplexing and measuring the response from several sensors, except that the RF is now pulse modulated at the source (using a RF switch), whilst a variable delay pulse operates a second RF switch at the receiver in order to select the sensor of interest. The pulse duration is determined by the separation in distance (and therefore time) between the sensors. The method is accurate, has very low crosstalk between sensors due to the high signal rejection of the gating switch, whilst length determination is straight-forward using the same null-frequency procedure described above.

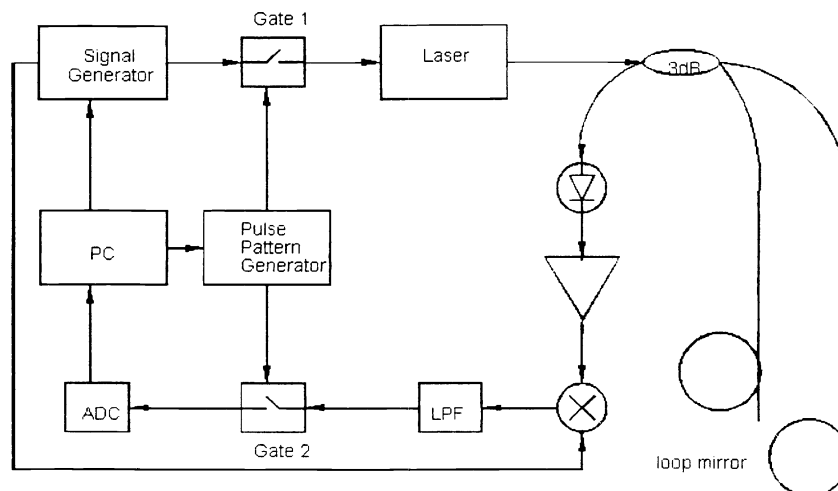

Figure 1. Sensor multiplexing system using gated RF signal

3. BRILLOUIN SYSTEM

Figure 2 shows the schematic of the Brillouin system. A strong light pulse, the pump, is launched into the fibre. It crosses a weak CW signal called the probe that propagates in the opposite direction. Stimulated Brillouin scattering occurs when the two signals overlap resulting in the amplification of the probe signal. The electro-optic modulator (EOM) is the key element in the setup since it is used, on the one hand, for pulsing the CW light from a single frequency laser to form the pump pulse, and on the other hand for the generation and frequency tuning of the probe signal. The frequency shift on the probe laser light is achieved by applying a microwave signal to the electro-optic modulator. This creates sidebands in the laser spectrum of the probe signal. When the microwave frequency is close to the Brillouin frequency shift, one of the sidebands of the probe light lies under the Brillouin gain spectrum and is amplified, as explained previously. The Brillouin gain spectrum, modified by the fibre strain, is determined by simply sweeping the microwave frequency applied to the modulator and recording the probe intensity.

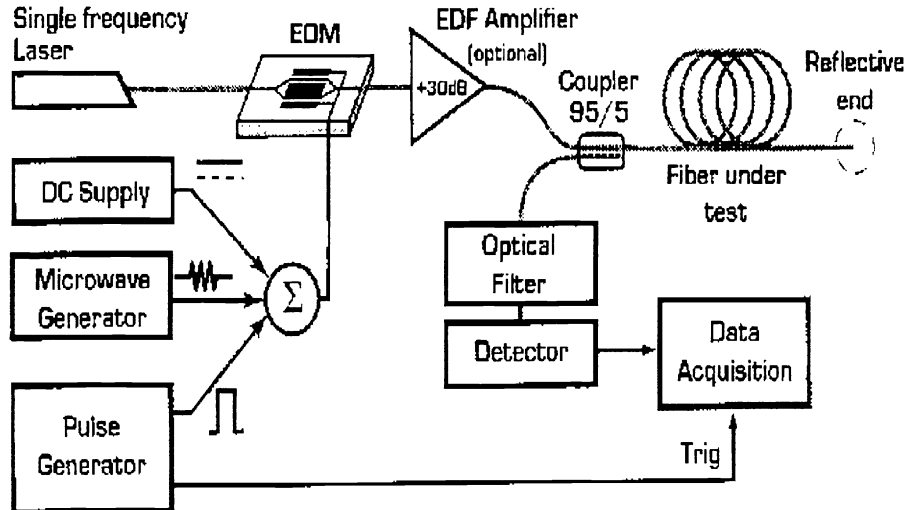

Figure 2. Schematic of Brillouin strain measuring system

4. RESULTS FROM RF SUB-CARRIER SYSTEM

A fibre optic sensor was glued to the surface of a single polyester strand of a four strand rope at an angle of 30 degrees. The rope was loaded (54kN maximum load on the first run, 44 kN maximum load on the second run), and for each run the applied strain was noted while the measured fibre strain (determined from readings from the fibre sensor) was calculated. The applied vs. measured strain is shown in Figure 3, noting that the fibre does not experience the same strain as the rope because of the effect of the winding angle.

5. RESULTS FROM BRILLOUIN SYSTEM

A length of parallel yarn (Kevlar) rope with a continuous length of optical fibre embedded at the core (laid parallel to the yarns, i.e. at 0° lay) was used for the experimental work. The rope had a calculated break strength (CBS) of 60kN. This rope was used for the Brillouin instrument based tests. Figure 4 presents the post-processed data from a series of straining test. The fibre was monitored using the EPFL Brillouin strain sensing system. The first half of the trace of Figure 4 shows results from a length of reference fibre which always remained unstrained. Loading was applied to the rope incorporating the fibre sensor which, in Figure 4, begins after the 21 metres point.

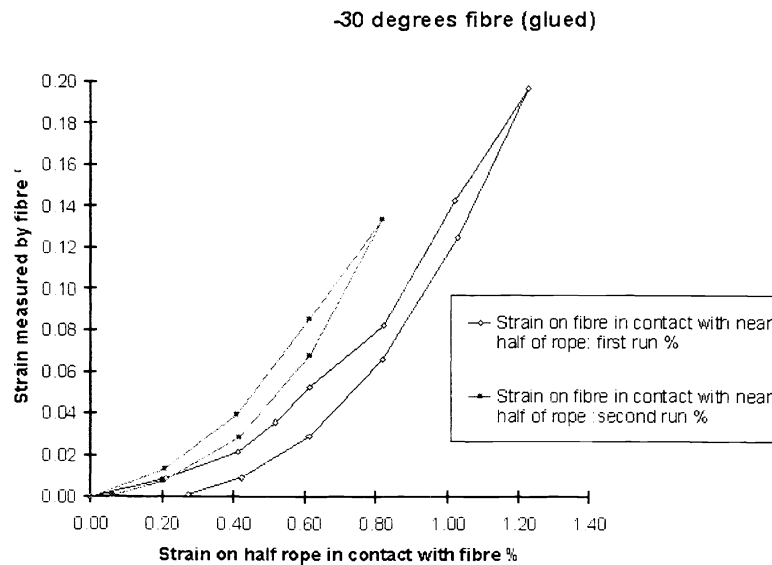

Figure 3. Measurement on polyester strand during loading/unloading

The load tests followed the following sequence - the corresponding results are also described:

- The initial bias trace (annotated as 3kN) shows that the optical fibre incorporated in the rope was initially in compression.
- The second trace (annotated as 10kN) shows that the unbonded optical fibre was able to pick up virtually all the rope strain - an extension of 58.8mm on a reference length of 15.3m is equivalent to 0.38% strain and the Brillouin system reported an increase from -0.13% to +0.22%.

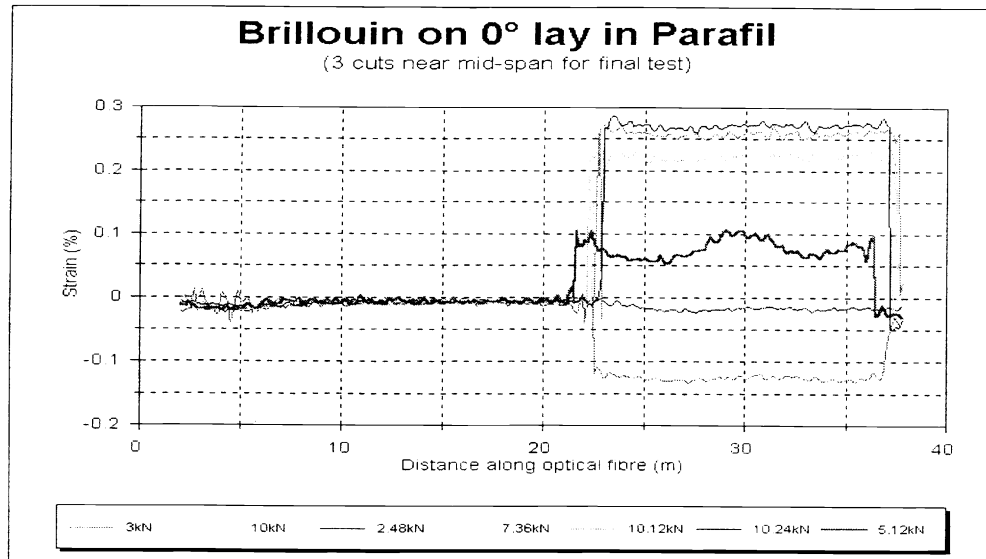

Figure 4. Conclusive monitoring of strain on small parallel yarn sample

- The third trace (annotated as 2.48kN) clearly shows that simply applying and removing the 16% CBS load once has removed most of the initial optical fibre compression.
- The fourth trace (annotated as 7.36kN) again shows that the unbonded optical fibre was able to pick up virtually all the rope strain - an extension of 24mm on a reference length of 15.3m is equivalent to 0.16% strain and the Brillouin system reported an increase from -0.02% to +0.13%.
- The fifth trace (annotated as 10.12kN) still shows that the unbonded optical fibre was able to pick up virtually all the rope strain - an extension of 47mm on a reference length of 15.3m is equivalent to 0.31% strain and the Brillouin system reported an increase from -0.02% to +0.27%.
- The sixth trace (annotated as 10.24kN) still shows that the unbonded optical fibre was able to pick up virtually all the rope strain - an extension of 51mm on a reference length of 15.3m is equivalent to 0.34% strain and the Brillouin system reported an increase from -0.02% to +0.28%.
- The final trace (annotated as 5.12kN) shows beyond any doubt that the Brillouin system can detect localised loss of strength (localised increase in strain) after the rope was deliberately damaged at its centre. This last result demonstrated the capabilities of the Brillouin system, in that it was able to clearly identify that the central portion of the rope was significantly weaker than the remainder.

6. CONCLUSION

Both optoelectronic sensing systems have been shown to successfully measure strain in rope samples incorporating fibre optic sensors. Considerable further research must still be undertaken to develop these systems into viable engineering solutions.

7. REFERENCES

1. T Kurashima, T Horiguchi, H Izumita, S Furukawa and Y Koyamada, "Brillouin optical fibre time domain reflectometry", *IEICE Trans. On Comms.*, 1993, vol E76B, pp382-390
2. M Volanthen, H Geiger and J P Dakin, "Time division multiplexing of multiplexed optical fibre strain sensors using sub-carrier interferometry", *Electronics Letters*, 1995, vol 31, pp1943-1944