

INTERFEROMETRY FOR POLARIZATION MODE DISPERSION MEASUREMENTS IN SINGLE-MODE FIBERS

N. Gisin*, L. Thévenaz**, J.-P. Pellaux***, R. Passy*, G. Bernasconi*

* University of Geneva, Group of Applied Physics, Rue Ecole-de-Médecine 20, CH-1211 Geneva 4, Switzerland.

** EPFL, Swiss Federal Institute of Technology, Laboratory of Metrology, CH-1015 Lausanne, Switzerland.

*** Orbisphere Laboratories, Puits-Godet 20, CH-2000 Neuchatel, Switzerland.

SUMMARY

We present two interferometric techniques for the measurements of the polarization mode dispersion of standard (ie circular) single-mode fibers. The first method uses an interferometric loop and works in the frequency domain. The second one uses a polarization maintaining Michelson interferometer and works in the time domain. Their output are related by a Fourier transformation. Both techniques provide information about the entire statistical distribution of polarization mode delays. Also, both techniques can be applied to the characterization of installed lines. The setups are presented, the principle of the measurements are discussed and examples of results are shown.

1. INTRODUCTION

The evolution of single-mode fiber systems has been driven essentially by the requirements of low attenuation and of increasing the transmission bandwidth through the reduction of dispersion effects. This article concentrates on the second requirement. If the chromatic dispersion problem got good solutions in the fiber design and characterization technology, it is not the case for the polarization mode dispersion metrology. Presently, mode number reduction is incomplete because the fabrication defects break the circular symmetry and the fundamental mode splits in two submodes, orthogonally polarized and propagating with different group velocities. The request for fiber characterizations, under this aspect, leads to polarization dispersion measurements.

A number of experimental techniques have been proposed to measure the polarization mode dispersion¹⁻⁸, most of them requiring discrete optics and polarization controllers. Also, most of them provide the polarization mode delay at a single

wavelength, which is insufficient to characterize a statistical phenomenon like random polarization mode coupling. The purpose of this paper is to show the potential of the interferometric methods applied to field characterizations of single-mode fiber lines. Two different configurations are proposed according to coherent and, respectively, incoherent interferometry techniques. The first configuration is an interferometric loop⁶ running with a tunable light source of high enough coherence for the existence of principal states of polarization², the test fiber being inside the interferometer. The second configuration is a polarization maintaining Michelson interferometer⁷ where the light source is a broad spectrum LED diode, the test fiber being between the source and the interferometer. In both these configurations the dispersion time is deduced from the fringes visibility variations given by the interferences between the different propagation paths in polarization state space. However, the scanned interferometer parameters, in order to vary the interference amplitudes, are different according to the configuration. In the Michelson interferometer case, the wavelength is fixed and the optical reference path is scanned giving directly the time separating the possible paths in (the polarization state space of) the test fiber, by the determination of the interference fringes packet position. In the loop interferometer, the configuration geometry is fixed and the light wavelength is scanned in order to obtain the phase variation between both the orthogonal principal polarization states and the time dispersion is obtained by Fourier transform of the interference amplitude as a function of light frequency.

Finally, we like to emphasize that the two interferometric approach of dispersion measurements that we present use the time domain and the frequency

domain, similarly to the well known attenuation measurements using the OTDR and OFDR techniques.

2. EXPERIMENTAL SETUPS

2.1 The Polarization maintaining Michelson interferometer is schematically shown in Figure 1 and corresponds to a modified version of a previously reported combined air-path, single-mode fibre interferometer⁹. In this scheme, the polarization maintaining single-mode coupler replaces the beam splitter and the entrance polarizer of the conventional Michelson interferometer¹, with the advantage of preserving polarization. The reference arm is the polarization maintaining pigtail coupled to a mirror at its end face⁷. The optical delay line is a variable air path controlled by a movable mirror. The measurements of the interferences' envelope is obtained by a synchronous detection of fringes passing over the detector. This interferometer is placed at one extremity of the optical fiber line under test. The light source consisting in a broad spectral LED diode pigtailed by a polarising optical fiber is placed at the other extremity.

When partially coherent light is launched at the Michelson interferometer, the output signal gives the Fourier transform of the input light spectrum centered at the position corresponding to equal group delays between the two arms of the interferometer. Because the fast and slow modes of the interferometer are completely separated, the system can be considered as a polarization analyzer. A single polarization can be selected by an appropriate choice of time delay in the variable air path. Therefore, the interferometer can be used to analyze the polarization mode delays of a single mode fiber. Notice that a normal single mode coupler could as well be used, provided the polarization modes of the test fiber are mixed - by a polarizer or simple by some mode scrambler - in order to allow them to interfere with each other.

When different group delays are introduced between the light source and the interferometer, these modes are able to interfere by projection over the same mode of the interferometer. The output signal results from the autocorrelation of the light entering the interferometer. The polarising optical fiber following the LED source is necessary because the phase of these fringes depend on the polarization state of the source. In particular the phase difference is π for orthogonal states, for unpolarized sources the fringes thus cancel.

Fig 1. Schematic diagram of the experimental setup using the Michelson interferometer configuration.

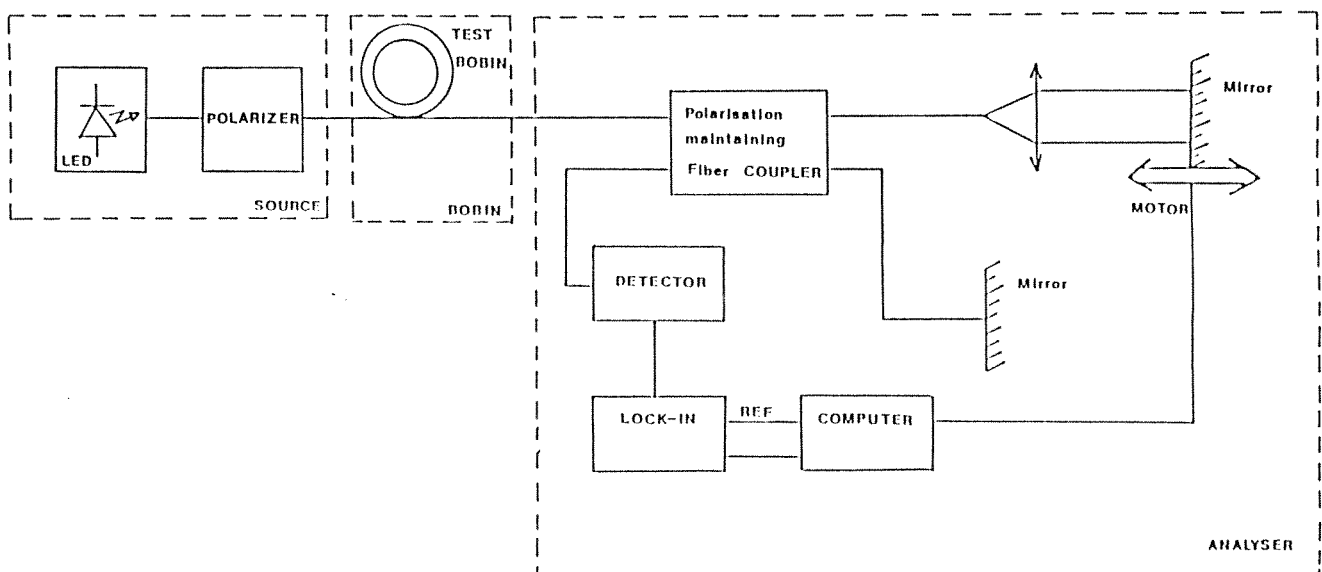

2.2. The interferometric loop shown in Figure 2 consists of a chopped white-light source spectrally filtered by a monochromator, a wavelength-independent single-mode coupler connects this source with the output of the optical fiber line and the input of the detector. The signal coming from the detector is amplified by means of a lock-in amplifier. At one extremity of the fiber loop the reciprocity of the interferometer is broken by a topological $\frac{\pi}{2}$ rotation¹⁰ of the orthogonal polarization modes in order to obtain interferences between the counterpropagating slow and fast principal polarization modes. In this case, the resulting interferences are independent of the state of polarization of the source. The light source coherence, however, must be sufficient in order to observe the interferences between the polarization modes given by the two principal states of the fundamental mode, ie the coherence length of the light must be long enough for the existence of two orthogonal privilege polarization states, the slow and the fast mode. When the source spectrum is scanned, the delay between the principal states gives rise to different phase differences between the interfering counterpropagating waves, resulting in a succession of constructive and destructive interferences, so that a wavelength scan results in a variation of the interference intensity. The polarization dispersion can then be evaluated by performing a Fourier transform.

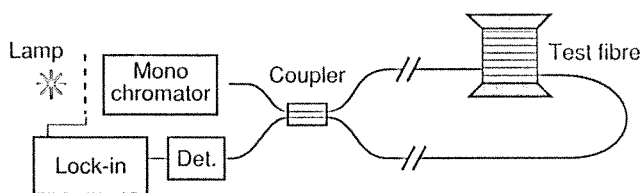

Fig 2. Schematic diagram of the experimental setup using the interferometer loop configuration.

3. RESULTS

3.1. Measure of High Birefringence Fiber

3.1. a) In the Michelson interferometer procedure, the light input signal consists of two coherent peaks delayed by the polarization mode dispersion of the

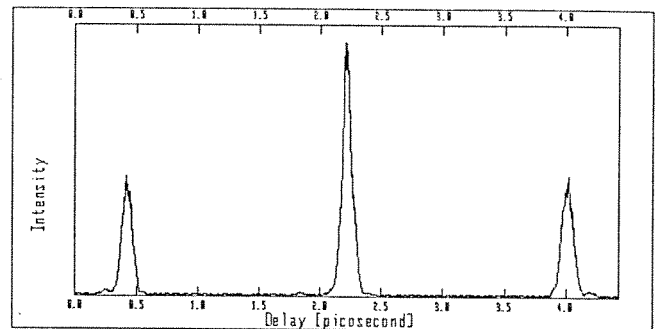

Fig 3. Envelope of the fringes when a polarization maintaining fiber is placed between the source and the Michelson interferometer. Only the interference of the slow mode of the interferometer is shown, a second triplet structures exists for the fast mode.

hi-bi fiber under test. The autocorrelation function gives rise to a triple structure, as shown in Figure 3. The amplitude of the satellite peaks depend on the coupling angle of the test fiber's and interferometer's axes and, finally, the polarization mode dispersion of the test fiber is given by the distance (time) between one of the two satellite peaks to the central one. If the angle between the birefringence axes of the test fiber and the interferometer's axes is 45° , then each polarization mode of the interferometer displays the same structure 1:2:1, but for the polarization mode dispersion measurement it is enough that this angle is different from 0° and 90° .

3.1. b) In the loop interferometer procedure, by wavelength scanning, the phase variation between the two polarization modes produce an intensity variation over the detector as shown in Figure 4. The intensity oscillation increases as the birefringence increases. Note that in this case the principal states of the fiber coincide with the birefringence axes.

The intensity variation frequency as a function of the wavenumber $\frac{2\pi}{\lambda}$ is equal to $\Delta\beta \cdot L$. This last value is deduced by Fourier transform as shown in Figure 5.

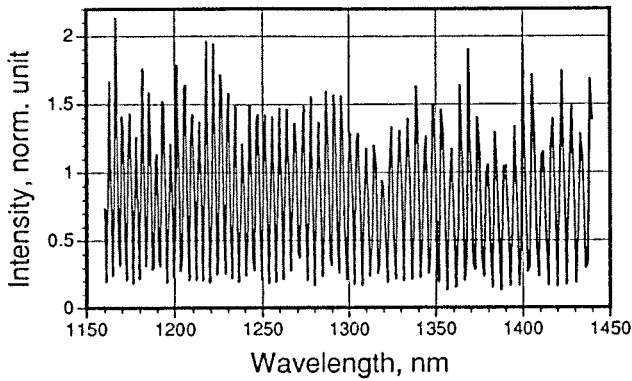

Fig 4. Intensity variation in function of wavelength when a polarization maintaining fiber is placed inside the interferometric loop.

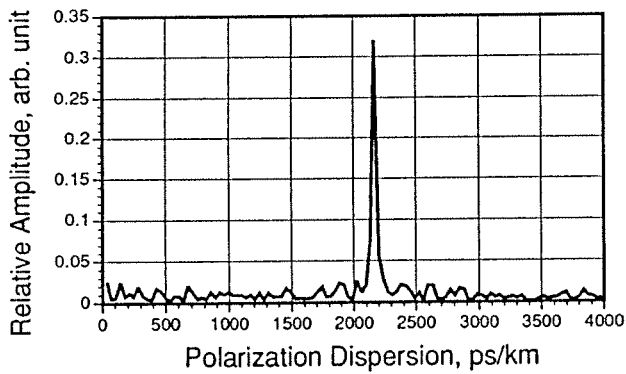

Fig 5. Fourier transform of Figure 4.

3.2. Measure of low (standard) birefringence fiber

We consider the single mode optical fibers with birefringence too weak to maintain the polarization, so that the fast mode and the slow mode easily couple. The analysis depends on whether the coherence time is shorter or longer than the polarization mode delay. For an arbitrary concatenation of polarization maintaining fibers an explicit computation, both for high coherent and low coherent sources, is presented in ref. 11.

In the Michelson interferometer approach the source is low coherent, we must thus consider a statistical distribution of the dispersion times because for wide wavelength spectra no principal polarization state exist. This is best understood if one thinks of a low birefringence fiber as a concatenation of homogenous polarization maintaining fibers of random length and (low) birefringence, the mode coupling taking place only at the junction between two trunks. The different propagation paths correspond then to the different combinations of polarization states in each trunk. If the coherence time is shorter than the polarization delays induced by some of the trunks, then a light pulse is split several times. The Figure 6 directly shows the time distribution after some coupling lengths as it accumulates around the mean time of flight in a gaussian like distribution. The spreading of this distribution grows with the square root of the fiber length. After subtraction of the central peak, the polarization mode dispersion is computed as the second moment. The solid curve is a numerical fit over the experimental points.

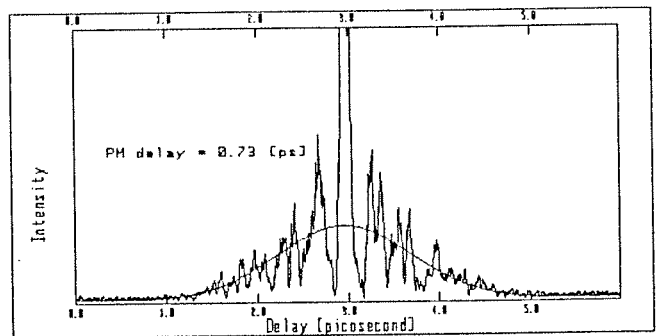

Fig 6. Example of the envelope of the fringes when a standard fiber is placed between the source and the Michelson interferometer. The lateral spread is the polarization mode delays distribution. The horizontal scale is directly related to the mirror's position in the reference arm.

In the loop interferometer approach the source is high coherent, we can thus use the formalism of principal states² which says that Δn vary to second order in λ so that the rate of change of the intensity with λ , shown in Figure 7, is a statistical measurement of Δn . The Fourier transform given in Figure 8 directly gives a representation of the probability density function polarization dispersion. The solid curve is a numerical fit over the Fourier transformed experimental points.

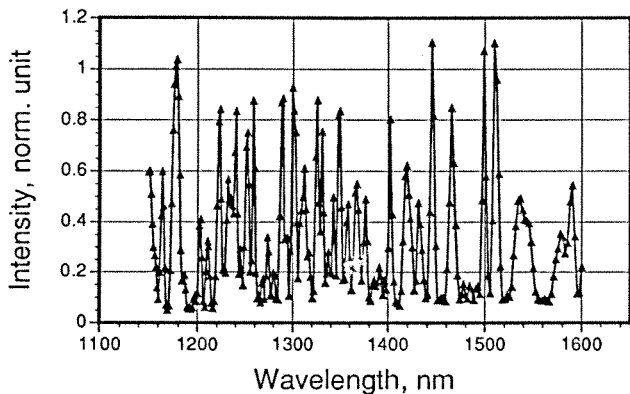

Fig 7. Intensity variation in function of wavelength when a standard fiber is placed inside the interferometric loop.

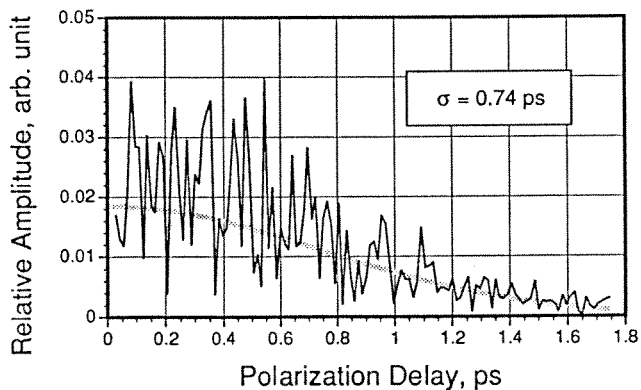

Fig 8. Fourier transform of Figure 7.

4. CONCLUSIONS

The applications of the interferometry techniques permits the polarization mode dispersion measurements in the time, respectively frequency domain with a high time resolution. Moreover these methods provide information about the distribution of polarization mode delays with respect to wavelength. Assuming that polarization mode dispersion variations in function of wavelength are representative of other variations, due to temperature and mechanical fluctuations, we conclude that the interferometric techniques provide much more and useful informations than techniques based on the measurement of the delay between the two principal states at a fixed wavelength and in a fixed environment.

The presented interferometric techniques can easily be implanted in field measurements for the characterization of the installed lines. The Michelson interferometer has a much higher dynamics, however both techniques are presently under further evaluations and comparisons. The next article of these proceeding¹² presents results obtained with both techniques.

Acknowledgment

It is a pleasure to acknowledge financial support from the Swiss PTT.

References

1. C. Edge, W.J. Stewart and I. Bennion, "Interferometric measurements of polarization mode dispersion of single-mode optical fibers", in Proceedings of ECOC'86, pp 271-274, 1986.
2. C.D. Poole, "Statistical treatment of polarization dispersion in single-mode fiber", Opt. Lett. **13**, pp 687-689, 1988.
3. C.D. Poole, "Measurement of polarization mode dispersion in single mode fibers with random mode coupling", Optics Lett. **14**, 523, 1989.
4. D. Andresciani, F. Curti, F. Matera and B. Daino, "Measurement of group-delay difference between the principal states of polarization on a low birefringence terrestrial fiber cable", Optics Lett. **12**, 844, 1987.
5. J. Pelayo, F. Lopez and F. Villuendas, ECOC'89, pp 510-513, 1989.

6. L. Thévenaz and Ph. Robert, ECOC'90, 1990.
7. N. Gisin, J.P. Pellaux and J.P. Von Der Weid, "Polarization mode dispersion of short and long single-mode fibers", accepted for publication, J. Lightwave Tech., 1991.
8. N. Gisin, J.P. Pellaux and J.P. Von Der Weid, Symposium on Optical Fiber Measurements, Boulder 1990.
9. L. Thévenaz, J.P. Pellaux, N. Gisin and J.P. Von der Weid, "Birefringence measurements in fibers without polarizer", J. Lightwave Technol., vol LT-7, pp 1207-1212, 1989.
10. O.J. Kwon, H.T. Lee, S.B. Lee and S.S. Choi, "Observation of a topological phase in a noncyclic case by use of a half-turn optical fiber", Opt. Lett. 16, 223, 1991.
11. N. Gisin and J.P. Pellaux, "Polarization mode dispersion: completely coherent versus completely incoherent sources", preprint, University of Geneva, 1990.
12. L. Thévenaz, ... EFOC/LAN 1991.