

September 1987

LRP 332/87

CONTROL SYSTEMS FOR THE TCV TOKAMAK

J.B.Lister, Ph. Mammillo and J.-M. Moret

Papers presented to the

**Europhysics Conference on Control Systems
for Experimental Physics**

Villars-sur-Ollon (VD)

September 28 - October 2, 1987

A FAST RESPONSE HYBRID LINEARISED CONTROL SYSTEM

J.B. Lister, Ph. Marmillod and J.-M. Moret
Centre de Recherches en Physique des Plasmas
Association Euratom - Confédération Suisse
Ecole Polytechnique Fédérale de Lausanne
21, Av. des Bains, CH-1007 Lausanne, Switzerland

Abstract: The TCV tokamak will require a fast control system capable of handling up to 126 input signals for synthesising 18 voltage signals as inputs to high power amplifiers. The synthesis algorithm must also vary rapidly during the 1 second tokamak discharge. This paper presents a locally linearised matrix operation solution to the problem, using hybrid digitally-controlled analogue techniques. The full transfer function, consisting of 2970 matrix elements, can be reloaded in 203 μ sec. Interfacing with the tokamak control system is simple, due to the lack of real-time constraints.

Introduction: The TCV tokamak, under construction in Lausanne, aims to study highly non-circular plasma equilibria, shaped by a total of 18 closely coupled poloidal field and transformer linkage coils. Such elongated plasmas are positionally unstable, and the equilibrium must be maintained by active feedback control. The time constant necessary is of the order of a millisecond due to the image currents induced in the conducting vacuum vessel shell between the plasma and the equilibrium coils. Nonetheless the coil power supplies will have to be as fast as possible.

The plasma shape is mainly derived from magnetic input signals, measuring magnetic fluxes and fields, although other measurements are imagined. The problem posed is to reduce up to 126 of these input signals in order to produce 18 separate voltage demand signals for the amplifiers, allowing us to maintain a predetermined plasma shape and position under active feedback control. Control must be provided from the breakdown phase, when the plasma current is started up, up to a full circular plasma of the order of 200 kA. Up to this point the plasma is positionally stable and the control is simple. When we elongate the plasma to fill the rectangular vacuum vessel we must also specify the desired plasma shape as well as its current and position. At any moment the stability of the control loops must be optimised, depending on the precise configuration.

Different algorithms have been studied [1,2], showing that the control can be locally linearised, but that the operating point must be varied smoothly. Such a local linearisation can be considered as a least-squares fit to the input signals, or to a moments weighting together with a transformation between different control spaces. Full proportional, integral and derivative (PID) dynamic responses must be provided, ideally separately for each control space variable.

Two approaches can be considered: (a) a fully digital system between the input and output signals and (b) a hybrid digitally-controlled analogue system. The fully digital solution might seem conceptually simpler at first sight, however, we have estimated that the approximately 3000 matrix cell operations will require 6000 floating point operations per cycle. If the bandwidth required is 1 kHz (a minimum tolerable value) and we only calculate 4 steps per period, then we need a calculation throughput of close to 100 MFLOPS. It seems to us that such a solution, although technically imagin-

able, would always be at the limit of what is required. In order to fight this limit the digital solution would have to be extremely well optimised for any one algorithm, losing the original advantage of the inherent simplicity of the digital design. This paper discusses the advantages and the conception of the alternative hybrid solution.

Philosophy: As a result of these general considerations, the chosen system must fulfill all the following requirements: (a) reduction of 126 input signals to 18 output signals, (b) provision of the response dynamics in the chosen control space, (c) bandwidth much greater than the power supplies to avoid high frequency phase errors within the control loop, (d) coefficients of the transfer function must vary rapidly, but smoothly, during a plasma cycle, and (e) the configuration must englobe all conceived algorithms for controlling the plasma shape.

If we restrict ourselves to locally linearised control algorithms, we can rewrite the combinations of all the input signals into the chosen control variables as a (126 \times 18) matrix multiplication, true for any of the control algorithms. The reference values in the control space, which define the desired plasma boundary shape and current, can also be composed by a similar matrix operation on a restricted set of the input signals plus a constant necessary to preprogram the reference signals for the plasma current. The control space error signals are therefore simply generated by a multiplication of the matrix difference (Matrix A of Fig. 1) with all the input signals.

Any particular control algorithm will define its 18-dimensional control space. The feedback dynamics, a full set of 18 PID operators, are imposed in this control space. In this way we can independently optimise the dynamics in each dimension, which is not the case if we attempt to incorporate the dynamics directly in the amplifier control voltages, as proposed in [1]. In that case any imbalance in the control space dynamics will lead to an excessively oscillating plasma response.

The control space response must now be transformed into the individual coil current responses, using a time-varying transformation (M^{-1} of Fig. 1). In general, each coil current response is summed over all the control space responses. When we redefine the control space we will inevitably have to redefine the individual coil current response, as well as the dynamics. For this reason the matrices A, PID and M^{-1} will be changed together each time we change the operating point about which the control is currently locally linearised.

Finally, since the coil currents are electromagnetically coupled, the coil voltage signals are obtained by multiplying the individual coil current responses by the inductance matrix. Since this matrix does not depend on the control algorithm it will not have to change at the same rate. However, it does represent the status of the poloidal coil supplies, and will be modified when one or more of the 18 supplies are open-circuited. In such a case

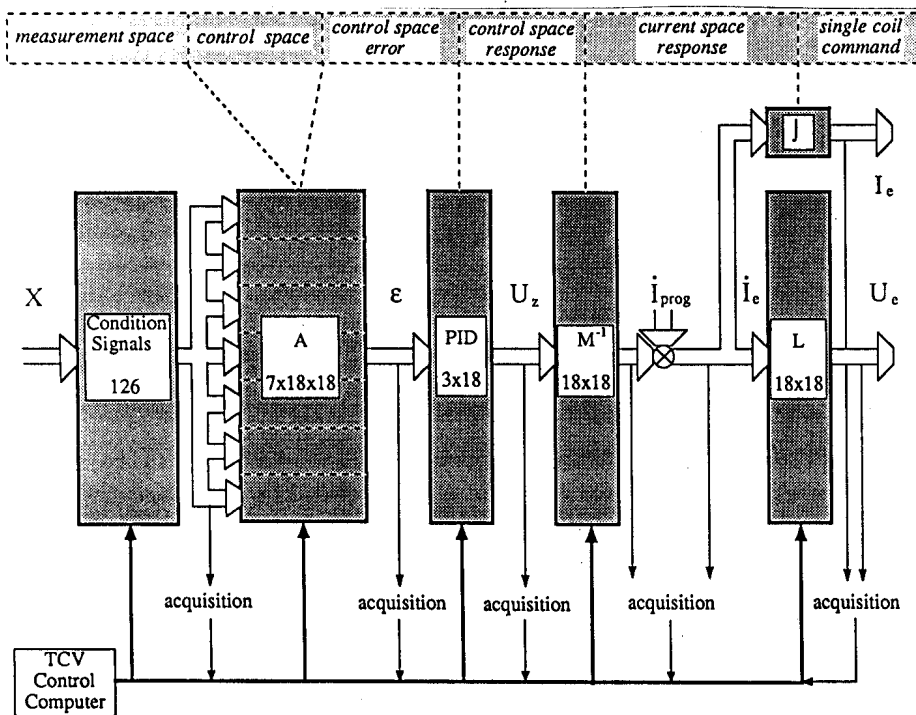

Fig. 1. Layout of the full system data flow.

it is clear that the control space dimension must also be reduced. If we operate with a control space which has a smaller number of dimensions than the number of power supplies, then the matrix M^{-1} can be modified to add the additional constraints necessary to define the individual coil current response signals.

The coil voltages U_e are purely inductive, and no compensation is made for the resistive voltage. A second feedback loop will be placed between the demand signals U_e and the thyristor supplies. This loop will take as input the demand voltages U_e and the demand currents I_e , also shown on Fig. 1, and will compensate the resistive voltage drop as well as any error between the demand signals and the coil voltages provided by the power supplies. This second loop is shown in Fig. 2.

We also provide for preprogramming the coil currents by injecting an external I_e demand signal vector as shown in Fig. 1. This vector is used essentially to preprogram the full set of 18 coil currents before the plasma discharge is initiated. In addition we provide a single coil test input for each of the 18 single coil feedback loops in Fig. 2.

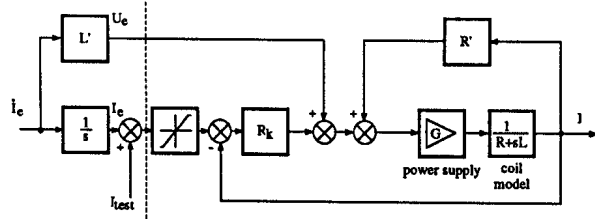

Fig. 2 Second control loop to compensate for errors and coil resistance.

This full system appears somewhat complex. We can imagine a control algorithm in which there are only 18 input signals and all matrices are diagonal. Such a system, in which only one input signal controls any one amplifier, has been successfully used for weaker shaping experiments on the DI-II tokamak. It is our opinion that the successful operation of such strongly shaped plasmas as are proposed for TCV, will require an extremely flexible approach, and that we should not attempt the experiment with a simplified system. The tendency will also inevitably be towards more complex algorithms as the experiment develops.

Technical solution: The proposed hybrid system layout keeps the sequential matrix operations physically separate. The 90 intermediate signals are acquired as routine diagnostic signals, to simplify the post-shot analysis of the feedback loop performance. Since the signals between matrices are in analogue form, they can be filtered, limited or amplified by using conventional signal processing cards.

The hardware proposed is centred around a single unit, the Base-cell, which performs an analogue multiply with a digitally controlled gain (Fig. 3). A typical example is the National Semiconductor MICRO-DAC (Trademark) which multiplies a voltage in the range ± 10 V by a 12-bit number yielding an output in the range ± 10 V. The unit is already double-buffered, and provides direct interfacing to microprocessors. The analogue bandwidth can easily be 100 kHz, satisfying our speed requirement admirably. The refresh time, using DMA from a 68070 microprocessor, is 0.6 μ sec. The buffered input data are read into the DAC on receipt of an external transfer signal. Quad versions of the same unit are also becoming available, reducing the board complexity.

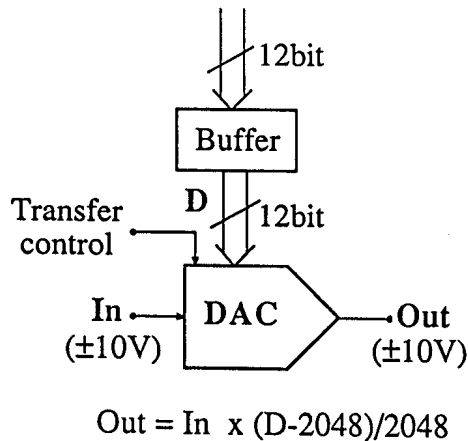

Fig. 3. Concept of the Base-cell.

Figure 1 shows that an 18x18 base-module matrix multiply is a judicious choice for modularising the system. A total of 7 such sub-matrices would be required for the full system. Figure 4

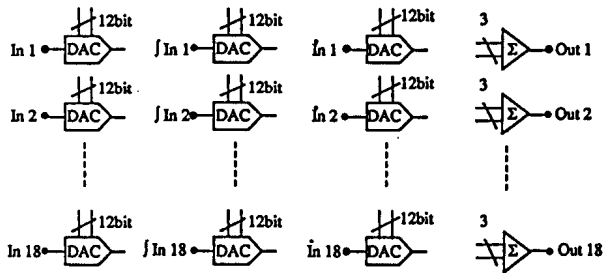

Fig 4. Construction of the 18-dimension PID.

illustrates a simple column and row arrangement of the 324 base-cells in the base-module. Each base-module can store up to 650 kBytes locally, providing real-time autonomy during the plasma shot. The sequencing of the matrices through the double-buffering is under program control, and takes ~200 μ sec per matrix refresh. Since the base modules are autonomous, the whole system can be refreshed in parallel in this same delay. The switching is rapid and is synchronised for the full system on receipt of a distributed external transfer control signal. The row and column addressing is by partial decomposition of the microprocessor address bus, and the 12 bit Base-cell input data are taken from the data bus.

The PID unit will be created out of a 3-column modified version of the base-module, as illustrated in Fig. 5. The integration and differentiation of the signals will be performed by analogue circuitry. The digital generation of the differential term is inherently noisy, and is thereby avoided using this hybrid system.

During operation, up to 500 individual matrices will be stored locally in each base-module, available for use in the subsequent shot. A minimum switching time of 200 μ seconds should easily allow us to fulfill the requirement that the changes in the matrix should not produce a significant step in the control error, which would lead to spikes on the voltage demand signals. The sequencing of the matrices will be by external triggering of the transfer control signal. This leaves us the option of preprogramming the evolution of the matrices, by predetermining the timing of these signals, or, alternatively, allowing the plasma evolution itself to determine the rate of sequencing. The latter seems more realistic, in that unless the shape and current have been correctly achieved for a given set of matrices, advancing the shaping would make little sense. In this way a condition on the error signals could prompt the next step.

The total data per Base-module will be 500x324 words, giving a system total of ~1.5 MBytes. (The final matrix L does not normally vary in time as it represents the coil and vessel configuration). Since this large quantity of data is not transferred in real-time on the TCV network [3], an RS232 serial link at 19.2 kBaud might be an adequate communications link, since we shall rarely refresh the complete set of 500 matrices between shots. This data rate corresponds to reloading 4-5 matrices per second between shots. During operation it is possible that the full set of

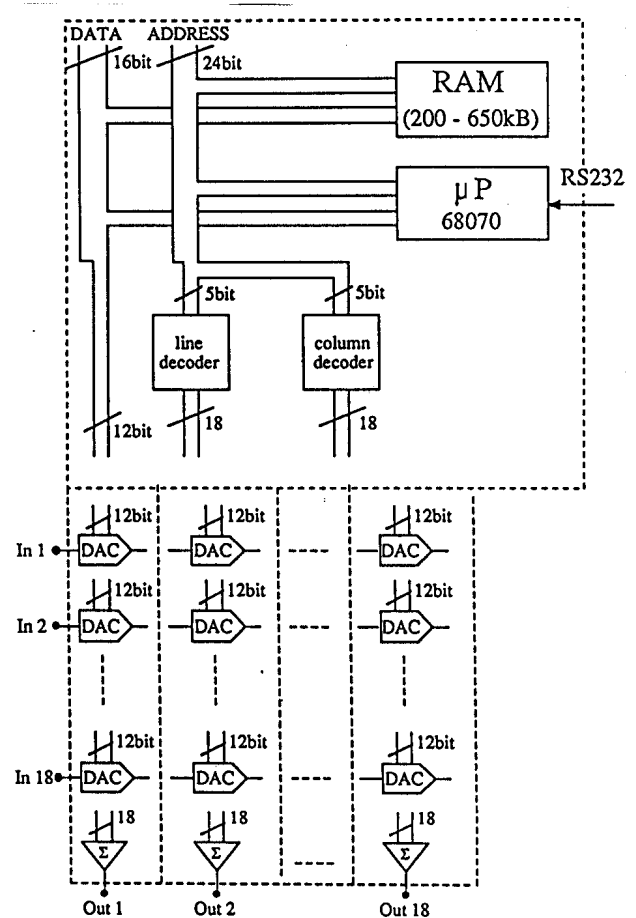

Fig 5. Integration of a full Base-module.

matrices will not be used in one shot. This would allow us to shuffle a library of matrices within the base modules, reducing the amount of reloading necessary. If this delay is considered too long, a standard parallel interface could be used. The data will be managed by a central microVAX control computer. It will store the libraries of matrices used, together with references to their use. For any particular plasma discharge, the full sequence of matrices used will be archived as part of the data file. This allows us to replay any particular discharge under identical conditions. The actual matrices will be calculated on a powerful local analysis computer.

Finally we mention that this proposed hardware solution to the complex control problem does not attack the difficulty of optimising the control algorithm or the dynamic response. The first problem is already under study using numerical simulations [1,2] and the second question of optimising the control on the device itself will also require a considerable effort.

Discussion: Are there any hidden problems? Since the system is fairly complex, effort will be devoted to developing simple self-test features. The intermediate signals will help in maintaining the system. The dynamic range of 12-bits is considered adequate, although we may need to redistribute the gains through the matrices to maintain full use of this dynamic range. Again, the intermediate signals will allow us to check on the LSB error propagation.

To summarize, we recapitulate the advantages of this proposed hybrid control unit:

- it provides a very large bandwidth, impossible with a digital system without reducing the generality of the solution
- it is conveniently modular
- diagnostic signals are available inside the control loop for performance analysis
- a general PID optimisation is possible by placing the PID in the control space.
- the system is trivially reprogrammed for testing any algorithm by reloading the linearised matrices.

References

- [1] F.B. Marcus, S.C. Jardin and F. Hofmann, Phys. Rev. Lett. 55, 2289 (1985).
- [2] F. Hofmann, private communication.
- [3] J.B. Lister, Ph. Marmillod, this Conference.

CONTROL OF THE TCV TOKAMAK

J.B. Lister and Ph. Marmillod
Centre de Recherches en Physique des Plasmas
Association Euratom - Confédération Suisse
Ecole Polytechnique Fédérale de Lausanne
21, Av. des Bains, CH-1007 Lausanne, Switzerland

Abstract: The TCV Tokamak will explore the possibilities offered by extremely shaped cross-section fusion plasmas. In this paper we shall discuss the network-distributed experimental control system which will operate the device. Real-time synchronous control is removed from the network, and is provided by intelligent externally synchronised slave modules. Such a philosophy was successfully implemented, at a reduced level of complexity, on the existing TCA Tokamak. Organisational control is provided, via DECNET and local PDP/VAX computers, around a centralised database for both machine control and configuration of the data acquisition.

Introduction: The TCV tokamak under construction in Lausanne will be a powerful and complex experimental system. Powers up to 250 MW must be handled for pulses lasting up to 1 second. A large variety of monitoring and experimental signals must be acquired at speeds from 1 Hz - 20 MHz. The equipment must be controlled with an acceptable range of synchronisation jitter varying from 1 second (e.g. valve opening) to 5 nsec (e.g. laser timing). Operation of the complete system relies heavily on operator interaction for the preparation of the experimental pulse, which occurs every 5 minutes, requiring simple man-machine interfacing.

During the pulse itself there can be no operator interaction and the experiment is controlled by a mixture of preprogramming and feedback loops. The full control and data treatment system is, therefore, extremely heterogeneous, differentiating it from other, may be larger, more homogeneous environments. Its geographical extent will cover 600 m² over 4 floors.

With the control and acquisition system we must:

- define and modify the pulse operating conditions
- survey and display the experiment status
- look for non-fatal fault conditions
- prepare all equipment for the following pulse
- define the data acquisition configuration for the following pulse
- archive all data relevant to an experimental pulse
- be indefinitely upgradable.

We have excluded, a priori, machine and personnel safety from this centralised system, imposing a rigid requirement that this be performed locally. Each subsystem is therefore responsible for its own safety and must protect itself against faults in other equipment. Once a major fault is diagnosed in any subsystem, a general ABORT is signalled to all equipment, starting a crash sequence which is obeyed independently. In addition to this major abort, a soft pulse termination will be automatically started on receipt of any soft fault condition. This is more of an operation condition than a safety feature. As a result of the exclusion of prompt safety actions from the control system, we can accept a much slower response time in the control network, which will significantly simplify the design.

Many different philosophies have evolved for controlling tokamak experiments, depending on

available budget and manpower. The present solution is proposed as being as simple as possible while fulfilling the cited requirements. Simplicity is in fact considered to be a major virtue from the point of view of the operation teams. The system must be functional by the end of 1989.

Integration: The first decision is to integrate the above functions, not separating the flow of control data and acquisition data. We must control the data acquisition process just as any other equipment, and we must also acquire much of the control equipment data, rendering any separation artificial. On the other hand, a monolithic solution would be unmanageable. A network-integrated system has been chosen, based on DECNET using thin-wire Ethernet between a mixture of PDP and microVAX computers, also compatible with the Ethernet network on the EPFL site (EPNET). It is hoped that restriction of network traffic to the equipment and software of one manufacturer will avoid many problems, and will reduce the effort required. A schematic layout of the whole system is shown in Fig. 1.

Local Controller: Since controlling the full experimental installation using PDPs would be prohibitively expensive as well as unnecessary, a second layer of distribution is provided by simple autonomous programmed controllers (SLAVES) which are cheap, simple to programme and to interface. The full system will have up to 50 SLAVE units. They will perform such menial tasks as activating relays, reading/setting voltages, reading temperatures, checking mains voltages and providing simple preprogrammed sequences of such operations. Typically they will be integrated in, and control, one piece of equipment. It is planned that the large majority of the control actions will be passed through these SLAVE modules.

The SLAVE will typically be controlled through a PDP (MASTER) unit which relays DECNET traffic to it via an RS232 fibre-optic serial link at 19.2 kBaud. The layout of a MASTER+SLAVE is shown in Fig. 2. The commands will typically originate from a centralised control programme in a microVAX computer. It is not yet clear whether autonomy of a MASTER+SLAVE subsystem would be worth the extra software involved. The 5-6 MASTERS will be distributed geographically to reduce the total cabling. A rigid protocol will be imposed on the MASTER-SLAVE communication. Transmission will be in ASCII code, with an evident syntactic sense where possible, such that the module can also be controlled locally from a directly connected terminal, or transparently from any network terminal. This restriction will slightly increase the data flow necessary to control the SLAVES. On the other hand switching from terminal-local to MASTER-remote operation involves only a change of signal routing, with no change in software. A terminal can also emulate a SLAVE module for testing the software, or can be inserted in the link to spy on the MASTER-SLAVE traffic.

The protocols and syntax of the communication will be independent of the particular SLAVE function, allowing the MASTER to read or write any data blocks to its SLAVES. Only within the SLAVE itself and at the forms interface at the operator consoles

will there be any module dependence. Usually this module dependent information will be in the form of a syntax table for both the operator display and the same table with branching lists within the SLAVE programme. This protocol restriction will allow us to add or modify any SLAVE module without rewriting any of the control software.

Timing: The SLAVE modules can execute sequences triggered by software commands when a jitter of 0.5 second is tolerable. This is typically acceptable during the whole of the pulse preparation cycle. Once the plasma discharge cycle is launched, the synchronisation must be much better. During the discharge, the SLAVE can be controlled by an external hardware trigger, leading to a jitter of typically 1 msec within the pulse, for even more precise synchronisation, a distributed timer will be used, constructed as special SLAVE modules, giving a jitter of less than 1 μ sec. To synchronise the distributed timers, a master clock will be sent out by fibre-optic. The clock frequency will be varied during the cycle, increasing progressively, to decrease the 1-bit timing interval to the precision required. A total of 65535 clock pulses will allow a one-second timing interval with a 100 μ sec clock interval whereas during the countdown the timing unit can be 10 milliseconds.

Coordination: As far as the SLAVE is concerned, the MASTER is only a local postbox, transparently relaying messages prompted from a central node (MANAGER) which will be a microVAX. Only the MANAGER will contain full details of the experimental configuration. These details will include the status of all remote modules, their data settings, their syntax tables, their physical location in the network, their software image category and so on. It handles these data interacting with the operator via its own workstation consoles or remote terminals, and will distribute brief instructions to the SLAVE and acquisition modules. The MANAGER-MASTER communication will be via permanently open channels for high-level task-to-task communication. In this way the MASTER has access to the central data bases in shared common memory in the MANAGER, eliminating disk I/O at all levels other than regular backup every minute.

Hierarchy: We impose a severe simplifying restraint on the communication: a SLAVE cannot interrupt its MASTER and a MASTER cannot interrupt the MANAGER. This forces the MANAGER to poll its MASTERS which in turn must poll their SLAVES. The two polling levels can cycle asynchronously, the MASTER retransmitting the data from its SLAVES upon request by the MANAGER. In order to minimise the extra cost of the polling, we shall reduce the response traffic to change-of-state information, and so very few extra overheads are consumed as a result of this simplification. Since safety is locally handled, the lack of an interrupt is not dangerous. We estimate that with 5-6 MASTERS and up to 50 SLAVES the full polling cycle will be less than 500 msec, compatible with the operator's reaction time.

Data Acquisition: The integration of control and acquisition functions allows SLAVE modules to perform slow and low volume acquisition (< 2kBytes/shot/SLAVE). This form of acquisition will be ideal for recording strain gauges, vacuum pressures, temperatures, position encoders etc. Above a rate of 100 Hz we shall use either existing in-house 12-bit 4 μ sec 16 channel ADC's or CAMAC ADCs. Since there will inevitably be a considerable quantity of CAMAC for data acquisition, the MASTER PDP 11/73 processor will often be inside the CAMAC controller itself (CES-STARBURST) with its peripherals in an ad-

acent Q-bus rack.

As well as a CAMAC interface, and the RS232 MUX interfaces, there will probably be several GPIB interfaces to control commercial instrumentation. It is not yet clear whether the use of CAMAC, GPIB bus and SLAVE equipment will fulfill all our requirements, or whether VME bus will also prove necessary, due to the large number of modules available commercially.

Due to the heterogeneous composition of the acquisition system, a similar transparent data base and communication will be used to configure the system and to retrieve the data. Unit-specific data will only appear in the user image and in the remote modules. We shall typically acquire up to 5 MB/shot. The MASTERS will be responsible for the retrieval of data from their modules, and the formatting and archiving on the distant storage disk. The MANAGER will only have to interrogate the MASTER for its data volume, and communicate a starting block to it, as well as provide a minimal amount of book-keeping. Since the data quantity is high compared with the organisational traffic, the bottleneck is not yet obvious. Since up to 15 seconds to archive the data after a shot is considered to be reasonable, the simple system proposed should be adequate.

Replay: An important role of the centralised data management is the archiving of all conditions of the plasma discharge, including especially all the equipment settings. Any archived discharge can then, in principle, be reloaded to be repeated exactly, or with minor modifications. This facility will simplify the work of the operating physicists.

Verification: Although the individual items of equipment must be locally protected against operator errors, a pre-discharge verification will be performed on the proposed settings, to check that they are within predetermined limits. As well as this, a pulse simulation will be run to predict the performance of the discharge to verify the compatibility of the accepted settings.

Preprogramming: Since many of the TCV subsystems function within feedback loops, we must provide pre-programmed reference waveforms. These will be generated by several means: a) by digitising pad, b) by reference to an old archived waveform, c) by modifying an old waveform or d) by software calculation.

Language: Both control and acquisition will be written in a high level language due to the simple access to the system services needed. Although the existing software from the TCA tokamak is written in FORTRAN, we are considering PASCAL in addition. The throughput efficiency is defined by only a minute portion of the total software, which can be optimised in the light of run-time performance tests.

Post Shot Analysis: The data will be centrally archived on mass-storage associated with a powerful local computer. Analysis of these data will be performed on 7-8 workstations clustered around this node, which will act as a data server. The removal of graphics work to the workstations will particularly reduce the heavily interactive workload, typical of such an experiment.

Summary: The proposed TCV control and data acquisition system is based on the following principles:

- Minimum hardware dependence due to the heterogeneous nature of the systems
- DECNET to distribute communication at high level throughout the site
- No real-time functions on the network more precise than 0.5 sec
- Hardware distributed safety and timing networks
- 3-level hierarchy to distribute the control functions down to simple autonomous programmable modules
- No interrupts upwards in the hierarchy, for simplicity
- Transparent data transmission at the highest level
- Availability of 4 local communication systems: RS232, CAMAC, IEEE, VME
- Written in a high-level language, FORTRAN or PASCAL.

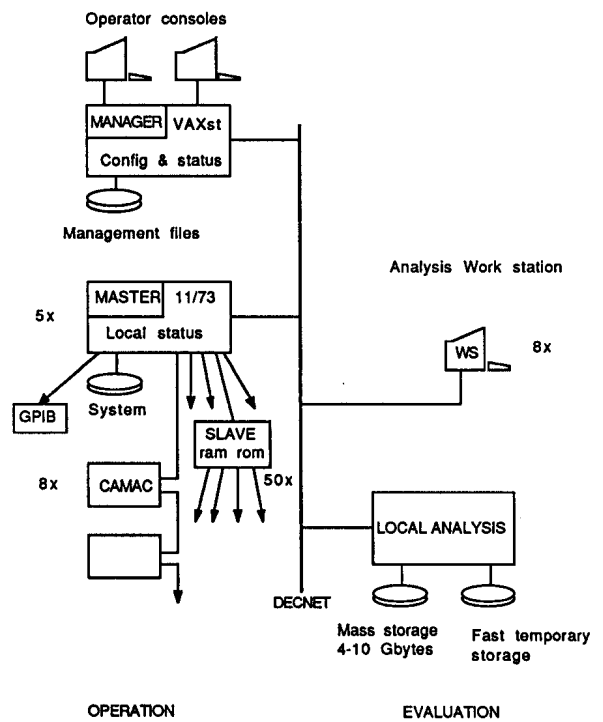

Fig 1. Total data flow layout.

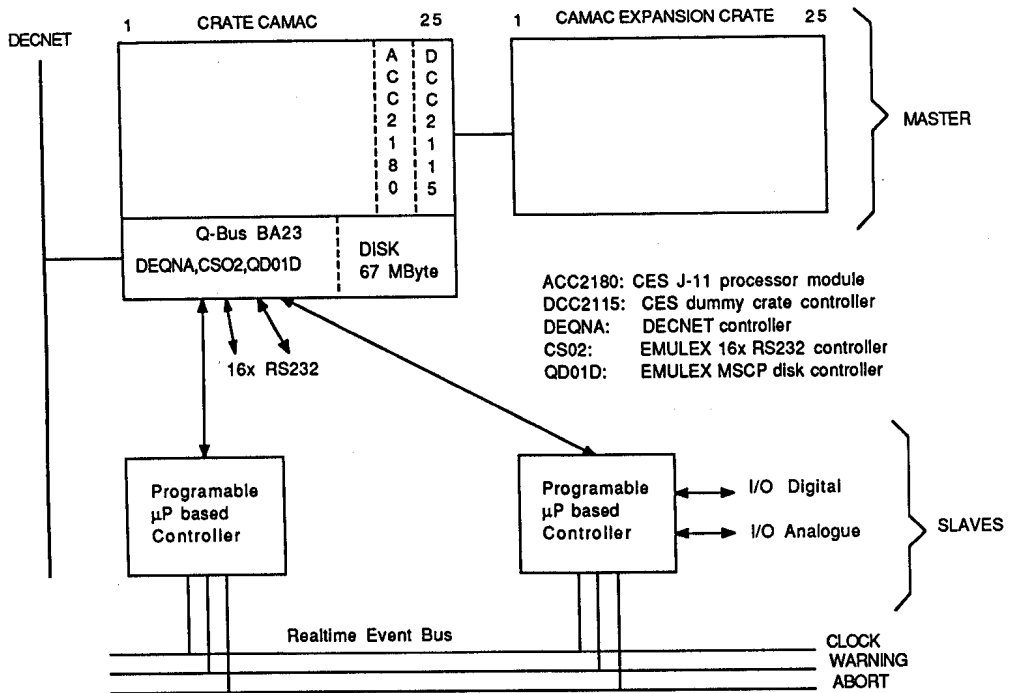

Fig 2. Schematic of a decentralised MASTER.