



Models and Tests of Anchorage Zones of Post-Tensioning Tendons

Modèles et essais de zones d'ancrage des câbles de précontrainte

Modelle und Versuche von Verankerungszonen von Vorspannkabeln

Olivier L. BURDET

Scientific Associate
Fed. Inst. of Technology
Lausanne, Switzerland

Carin L. ROBERTS

Ph. D. candidate
Univ. of Texas
Austin, TX, USA

Gregory L. FENVES

Prof. of Civil Eng.
Univ. of California
Berkeley, CA, USA

David H. SANDERS

Prof. of Civil Eng.
Univ. of Nevada
Reno, NV, USA

John E. BREEN

Prof. of Eng.
Univ. of Texas at Austin
Austin, TX, USA

SUMMARY

This paper presents the results of an investigation of the behaviour and the design of anchorage zones of post-tensioning tendons. The analytical component is a combination of Finite Element Analysis and Strut-and-Tie Models. A total of more than 60 tests of anchorage zones are included in discussion and practical guidelines for the design proposed for incorporation in the AASHTO Bridge Design Specification are outlined.

RÉSUMÉ

Cet article présente les résultats d'un projet de recherche sur le comportement et le dimensionnement des zones d'ancrage des câbles de précontrainte. La partie analytique comprend à la fois une analyse par la méthode des éléments finis et des modèles de treillis. Au total, cet article inclut les résultats de plus de 60 tests expérimentaux de zones d'ancrage et inclut des directives pratiques qui ont été proposées pour être incluses dans la norme américaine de ponts routiers AASHTO.

ZUSAMMENFASSUNG

Im vorliegenden Bericht werden die Resultate eines Forschungsprojektes über das Verhalten und die Bemessung von Verankerungszonen von Vorspannkabeln beschrieben. Der analytische Teil beinhaltet sowohl Finite Element Berechnungen als auch Fachwerkmodelle. Die Resultate von mehr als 60 Versuchen an Verankerungszonen werden aufgeführt. Weiter enthält dieser Bericht praktische Richtlinien, die für die Aufnahme in die amerikanische Strassenbrücken-Norm AASHTO vorgeschlagen wurden.



1. Introduction

The quest for development of a consistent approach to structural concrete clearly requires a hierarchy of highly transparent design oriented analysis tools [2]. These will range from relatively traditional section mechanics principles suitable for use in B-regions to the more intuitive strut-and-tie models (STM) or more formal elastic or non-linear finite element analyses (FEA) required for the D-regions. Scordelis [12] indicates that while the latter are extremely useful, "... it is imperative that experienced and qualified structural engineers be involved in the interpretation of the results using their judgement and knowledge of structural behavior..." MacGregor [5] reiterates this need but gives special emphasis in the D-regions saying "... the details of the reinforcement in the discontinuities control the strength of these regions and hence must be considered by the structural engineer." Marti [6] suggests that in usual applications of STM, the design is rather insensitive to the assessment of the effective concrete stress, f_c . While this is true in many applications, it is clearly not true in design of post-tensioned anchorage zones. In such discontinuity zones, the very large forces transmitted to the concrete by the tendon anchorages cause very high local stresses on the concrete. The spreading of these forces through the member causes substantial transverse

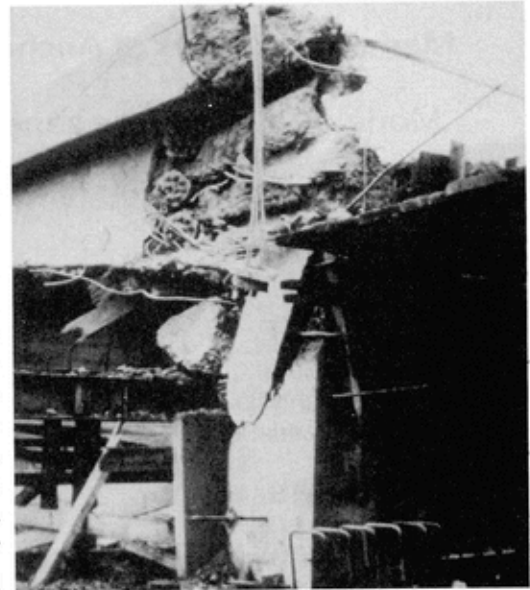

Figure 1: Failure of an Anchorage Zone in a Pedestrian Bridge during Construction

stresses and forces. Problems both at the serviceability limit state, with undesirable cracking, and at ultimate, with possible brittle and explosive failure of the anchorage zone need to be prevented.

Test results and failures during construction (See Figure 1) indicate that compressive stresses in unconfined nodes or at the intersection of confined nodes and unconfined struts often govern actual capacity of anchorage zones. This particular detailing application thus poses much more of a challenge to the development of detailing methods since assessing node and strut capacity is far more difficult than providing proper tie capacity through dimensioning of reinforcement.

This paper describes current progress on an on-going NCHRP sponsored study at the University of Texas at Austin to investigate the behavior of post-tensioning tendons anchorage zones, to provide guidance and to suggest specific provisions for anchorage zone design for the AASHTO Bridge Specification [1].

2. State of Stresses in an Anchorage Zone

The state of stresses in the anchorage zone of a post-tensioning tendon is very complex. Within very short distances, the stresses parallel to the tendon vary from very high compressions (often in excess of the uniaxial compressive strength of the concrete) ahead of the anchorage device to the average compressive stress induced by the post-tensioning, usually in the vicinity of $0.45f_c'$. Perpendicular to the axis, the stresses vary from very high compressive stresses under the device to tensile stresses which often exceed the tensile capacity of the concrete at a certain distance from the anchorage. Figure 2 identifies the major areas of tensile stresses in a simple anchorage zone. The tensile force caused by the lateral spreading of the tendon force from the anchorage device to the entire cross section is often called bursting force in the literature. The force parallel to the concrete surface has in the past often been called spalling force. Because this term implies that this force can cause spalling of the concrete, which is not the case because the force acts parallel to the face of the concrete, and not perpendicular to it, it is more appropriate to call it *edge tension force*. Edge tension forces also occur between anchorages acting on the same concrete surface, and on faces parallel to the axis of the tendon.

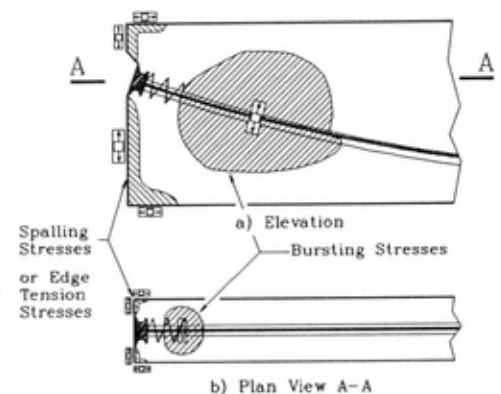

Figure 2: Tensile Stresses in the Anchorage Zone

3. Local Zone - General Zone Concept and Modes of Failure

As a consequence of the complex state of stresses, various modes of failure have been observed for anchorage zones. Aside from failures caused by insufficient material properties or lack of equilibrium, the failures of anchorage zones can be categorized as follows:

- **Local compression failure**, in which the failure occurs at a very short distance from the anchorage device, and is caused by lack of confinement in the area immediately surrounding the anchorage device.
- **Compression failure**, similar to the previous mode failure, but with the difference that the failure occurs at a larger distance from the anchorage device, which is itself sufficiently confined.
- **Tension failure**, in which the reinforcement provided to resist the tensile force induced by the spreading of the concentrated tendon load is insufficient.

Figure 3 shows two regions in the anchorage zone. The *local zone*, in the immediate vicinity of the anchorage device, is highly dependant on the post-tensioning system and is the responsibility of the supplier of the anchorage device. The *general zone* is more remote from the anchorage device and is less influenced by the post-tensioning system. It is the responsibility of the structural engineer. Of the three modes of failure described above, the first one occurs in the local zone, the second mode of failure occurs in the general zone, most often at the interface with the local zone, and the third mode of failure occurs in the general zone.

In order for anchorage devices to be deemed satisfactory, they need to either meet maximum bearing stress and minimum stiffness requirements or to be tested following a prescribed testing procedure described in Section 4. The distinction between local and general zone gives flexibility to the constructor, who can choose the anchorage device and the post-tensioning system, without jeopardizing the integrity of the structure, and without unduly complicating the work of the design engineer.

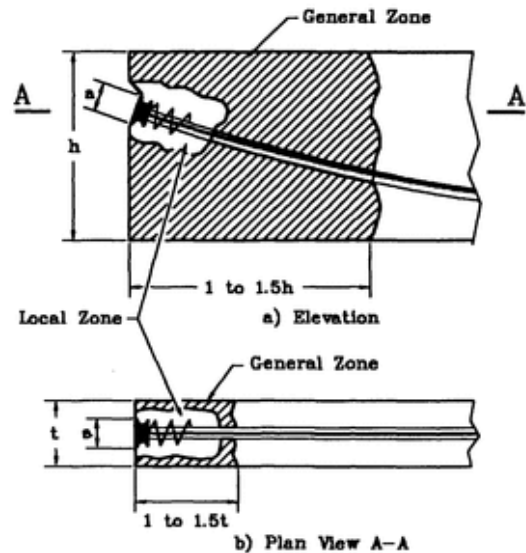

Figure 3: Local Zone and General Zone

4. Local Zone Tests by Roberts

A part of the NCHRP Anchorage Zone research project consisted in an investigation focusing on the behavior of local anchorage zones both at service state and at ultimate. The purpose of this study by Roberts [9] was to define the test procedures and compliance criteria for the testing of anchorage devices. Roberts tested 31 local zone test specimens. The behavior of local anchorage zones was found to be sensitive to the type and amount of confining reinforcement, as well as to the cover provided around the anchorage device. Existing formulae by Richart [8] and Nyogi [7] were enhanced to give a better prediction of the strength of a local zone. Cyclic testing of local zones gives results similar to extended (48 hours) testing, and is more representative of the behavior of anchorage zones under field conditions than monotonic testing. A standardized testing procedure for the local zone was proposed by Roberts for introduction in the AASHTO Bridge Specification.

5. Finite Element Analysis and Strut-and-Tie Models

It is not practical to test all possible general zone configurations, therefore the design of the general zone must be approached in a different manner than the local zone. The number of variables affecting the design of the anchorage zone remains large even though the local zone has been addressed. A survey of the current design practice in the United States by Sanders [10] showed that the post-tensioning industry is very creative. Tendons often present an eccentricity, an inclination and a curvature in the anchorage zone. Multiple tendons are commonly used, in groups of two to six tendons. Transverse post-tensioning and transverse reactions are often present in the anchorage zone. Special geometries are used to introduce the post-tensioning force to the section, using for example blisters or ribs. The first phase did not consider the expanding field of external post-tensioning.

The project was set up to use a combination of elastic finite element analysis, strut-and-tie models and physical tests. Linear elastic finite element analysis offers the advantage of being a well known method of obtaining the internal state of stresses in a body. As pointed out by

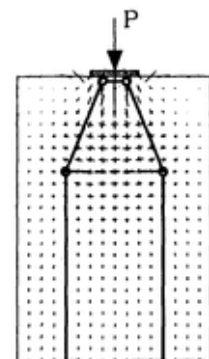

Figure 4: Simple Strut-and-Tie Model with Elastic Stress Vectors

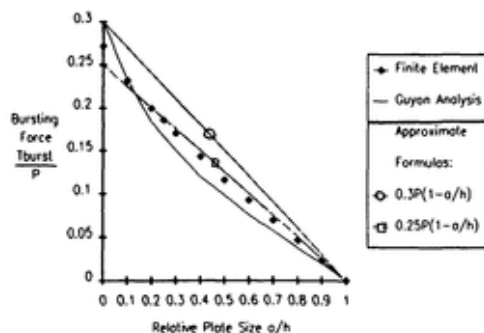

Figure 5: Bursting Force for Concentric Tendons

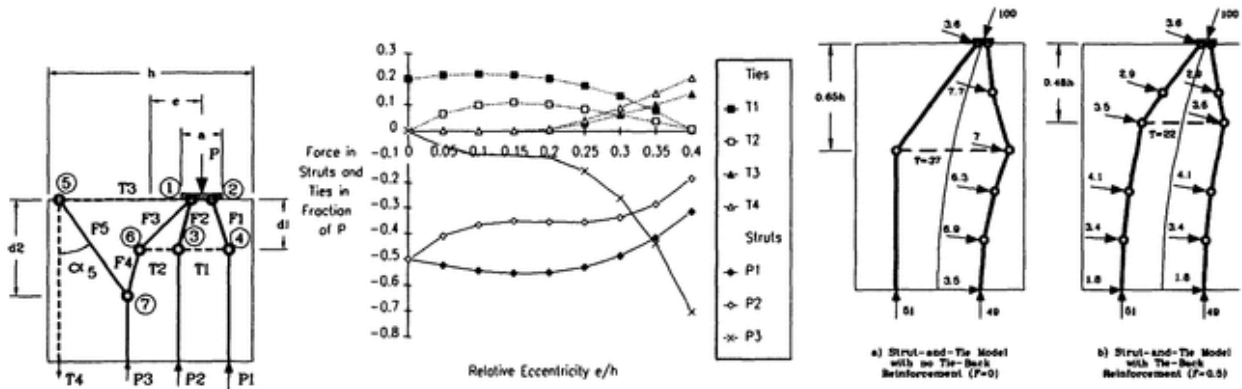

Figure 6: Strut-and-Tie Model of an Eccentric Function of the Anchorage Zone
 Figure 7: Forces in the Struts and Ties as a Function of the Eccentricity
 Figure 8: Strut-and-Tie Model of an Anchorage Zone with a Curved Tendon, Eccentricity 0.25h and Initial Inclination 20 degrees

Schlaich [11], the elastic state of stresses constitutes a good starting point for the development of strut-and-tie models. Of special interest is the representation of the principal stress vectors shown in Figure 4. These vectors give a good idea of the flow of forces through the anchorage zone and are helpful in assessing the adequacy of a strut-and-tie model. The physical test specimens by Sanders [10] were used to demonstrate the validity of the models and to calibrate the design formulae.

Figure 5 shows the bursting force obtained by integrating the elastic stresses perpendicular to the tendon path, along with the force obtained from the simple strut-and-tie model shown in Figure 4. As can be observed, the correlation is quite good. The figure also shows Guyon's equation [4] for the same force.

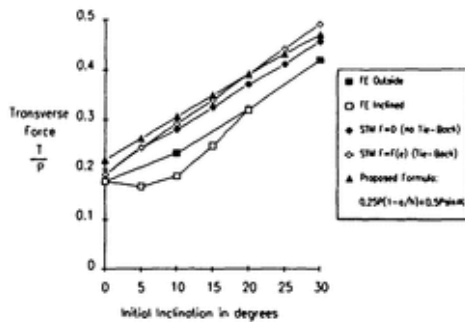

Figure 9: Transverse Bursting Force as a Function of the Initial Inclination for an Initial Eccentricity of 0.25h

Figure 5 shows the results obtained from the finite element analysis and the values predicted by an approximate formula as outlined in Section 6. In a simplified fashion, the increase in tensile force caused by the inclination of the tendon can be approximated as one half of the net shear on the general zone summing the effect of external loads and the transverse component of the post-tensioning force. This corresponds to the intuitive idea that roughly half of the force is resisted by each compression strut.

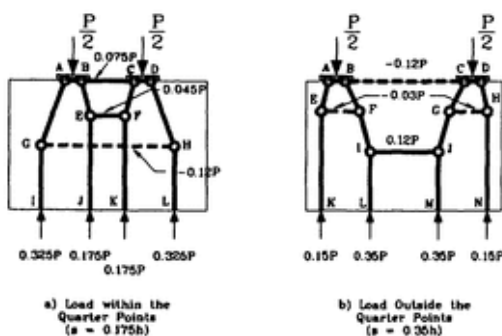

Figure 10: Examples of Strut-and-Tie Models with two Tendons

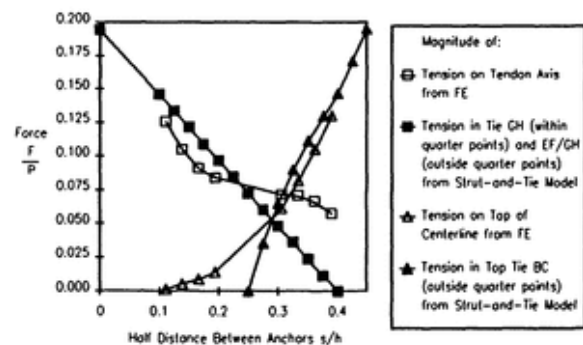

Figure 11: Tension Forces in an Anchorage Zone with Two Tendons

The effect of groups of tendons was investigated, and it was found that, for rectangular sections with straight tendons, the largest tensile forces are induced when only two tendons are used. Figure 10 shows the two basic configurations for two anchorages. If both tendons act within the kern of the section, the state of stresses is similar to that induced by a single anchorage device. As the tendons move outside the kern, an increasingly large edge tension force is induced between the anchorage devices close to the surface of the concrete. Figure 11 shows the edge tension force between the anchorages as a function of the spacing of the anchorages.

Because the compressive stresses in the immediate vicinity of the anchorage device are usually higher than the uniaxial compressive strength of the concrete f'_c , the verification of the capacity of the concrete compression struts is critical. Most authors assume that the limiting stress in the concrete struts is some fraction of f'_c , which is too constraining for anchorage zones. Sanders [10] incorporated the effect of confining reinforcement in a strut-and-tie model. For most practical cases, however, the checks involved in such calculations are beyond the capabilities of the engineer. Therefore, the local zone acceptance tests are relied on for determining the adequacy of the confined node. The critical section for the verification of the compressive stresses in the concrete struts is defined at a certain distance from the anchorage device (in general at one times the lateral dimension of the anchorage device). This allows one to check the compressive stresses in the concrete against the conventional value of $0.70f'_c$, which is commonly accepted for strut-and-tie models.

6. Design Method for Anchorage Zones

The goal of the NCHRP Anchorage Zones research project is the elaboration of a clear, consistent and easily applicable method for the design of anchorage zones of post-tensioning cables. Assuming that the engineer has a good knowledge of the location and magnitude of the force for each tendon, some idea of the size of the anchorage device that will be required to transmit the force and the assurance that the anchorage device used satisfies the testing requirements of Section 4, guidelines for the design of the general anchorage zone are needed. A number of procedures are suggested in the proposed AASHTO revisions. Two general procedures are allowed. One is a detailed elastic analysis such as a valid finite element analysis (FEA). Rules are provided for integrating tensile stresses and selecting appropriate limiting stress values. The second procedure allowed is the strut-and-tie model (STM). Since this equilibrium based procedure is not sensitive to compatibility induced stresses at service load levels, such as edge tension, or spalling stresses around anchorages, certain guidelines are provided requiring supplemental spalling crack control reinforcement. Recognizing that either FEA or STM solutions may require considerable extra effort for the design of some relatively simple but common applications, an approximate procedure is also included. This procedure was developed from the results of FEA and STM parametric studies [3]. It uses relatively simple formulae to determine the magnitude and location of the bursting force and to check the compressive stress at the interface between the local zone and the general zone. It is limited to the case of a single anchorage, or of a single group of closely spaced anchorages acting on a rectangular cross section.

7. Evaluation of the Methodology based on Test Results by Sanders

Sanders [10] conducted a series of 36 tests of anchorage zones. In the specimens modelling single tendon anchorage zones, the reinforcement patterns and the tendon eccentricity, inclination and curvature were varied. Tests of anchorage zones with multiple tendons were also conducted, with the prime variable being the spacing between the anchors. The cracking load of 31 of the specimens by Sanders was estimated based on the elastic stress distribution obtained from a two-dimensional Finite Element Analysis, and the tensile strength of the concrete measured from split-cylinder tests. The average ratio of actual to predicted cracking load is 0.91, with a standard deviation of 0.22. Figure 12 shows the ultimate load reached by the same series of specimens, along with the ultimate load predicted using strut-and-tie models based on elastic stress resultants at the end of the general zone. The average ratio of predicted to ultimate is 1.44, with a standard deviation of 0.44. Sanders [10] developed enhancements to the cracking load prediction, including the effect of the reduction of the tensile strength of the concrete caused by the three-dimensional state of stresses in the anchorage zone. Taking this modification into account, the average ratio of actual to predicted cracking load becomes 1.05 for all tests, with a standard deviation of 0.20. For the ultimate load, Sanders also developed an enhanced STM which includes the effect of a limited plastification of the concrete in the immediate vicinity of the anchorage device. Taking this modification of the model into account brings the average ratio of the predicted ultimate load to the actual ultimate load to 1.19, with a standard deviation of 0.19.

One of the most notable observations made during the evaluation of the test results is the fact that in the large majority of the cases, the capacity of the anchorage zone is controlled by the strength of the compression struts at the interface between the local zone and the general zone. At this location the concrete has no confinement, and is exposed to very large compressive stresses. Thus, increasing the reinforcement of the general anchorage zone will in many cases lead to little or no improvement of the overall strength of the anchorage zone. This is confirmed by the observation of Stone and Breen [13], who noted that increasing the amount of orthogonal reinforcement



(the reinforcement provided in the general zone) is not nearly as effective as using longer and heavier spirals, which confine the local zone and have the effect of displacing the interface between the local zone and the general zone to an area of lower compressive stresses. For design purposes, it is in any case advisable to remember that the stresses in the concrete struts often control the design. Also notable is the effect of tensile stresses existing in the anchorage zone. The resistance these stresses provide is usually neglected in the design, but it nevertheless plays an important role in the behavior of anchorage zones. In several cases it was observed that the strength of the anchorage zone exceeded that predicted based on the capacity of the tension ties alone. Burdet [3] suggests that this additional strength is caused by the fact that a part of the concrete at the base of the specimens remained uncracked up to failure, thus providing an additional tensile capacity to resist bursting forces.

8. Conclusions

The analysis, behavior and design of anchorage zones of post-tensioning tendons was investigated using a combination of Finite Element Analysis, Strut-and-Tie Models and experimental test specimens. This combination allowed minimization of the number of required experimental specimens and generalization the results in the form of simple design formulae. A consistent design methodology allowing use of finite element analyses, strut-and-tie models, and for certain frequently occurring cases, relatively simple design formulae was developed and has been proposed for inclusion in the AASHTO Bridge Design Specification. A standard testing procedure for anchorage devices and their necessary confinement was also proposed.

The cracking loads computed based on the elastic stresses and the split cylinder strength of the concrete are slightly smaller than the actual cracking loads, possibly because of the detrimental effect of the transverse compression. The ultimate capacity of anchorage zones can be conservatively predicted using the Strut-and-Tie Model. This investigation clearly indicates the critical nature of the compressive struts in anchorage zones. This differs from many other D-region applications in which the struts are not as critical.

References

- [1] American Association of State Highway Transportation Officials (AASHTO), "Standard Specification for Highway Bridges", 13th edition, 1983.
- [2] Breen, J.E., "Why Structural Concrete," Final Report IABSE Colloquium on Structural Concrete, Stuttgart, April 1991.
- [3] Burdet, O.L., "Analysis and Design of Anchorage Zones in Post-Tensioned Concrete Bridges," PhD dissertation, University of Texas at Austin, May 1990.
- [4] Guyon, Y., "Prestressed Concrete," John Wiley and Sons, New York, 1953
- [5] MacGregor, J.G., "Sub-Theme 2.4 - Dimensioning and Detailing," Final Report IABSE Colloquium on Structural Concrete, Stuttgart, April 1991.
- [6] Marti, P., "Sub-Theme 2.4 - Dimensioning and Detailing," Final Report IABSE Colloquium on Structural Concrete, Stuttgart, April 1991.
- [7] Nyiogi, S.K., "Bearing Strength of Reinforced Concrete Blocks," ASCE Structural Division Journal, Vol. 101, No ST5, May 1975.
- [8] Richart, F.E., Brandtzaeg, A., and Brown, R.L., "A Study of the Failure of Concrete under Combined Compressive Stresses," Research Bulletin No 185, University of Illinois Engineering Experimental Station, 1928.
- [9] Roberts, C.L., "Behavior and Design of the Local Anchorage Zone in Post-Tensioned Concrete," MS thesis, University of Texas at Austin, May 1990.
- [10] Sanders, D.H., "Design and Behavior of Post-Tensioned Concrete Anchorage Zones," PhD dissertation, University of Texas at Austin, August 1990.
- [11] Schlaich, J., Schäfer, K., Jennewein, M., "Towards a Consistent Design of Structural Concrete," PCI Journal, Vol. 32, No 3, May-June 1987, pp 74-151.
- [12] Scordelis, A.C., "Analysis of Structural Concrete Systems," Final Report IABSE Colloquium on Structural Concrete, Stuttgart, April 1991.
- [13] Stone, W.C., Breen, J.E., "Behavior of Post-Tensioned Girder Anchorage Zones," Center for Transportation Research Report No 208-2, University of Texas at Austin, January 1981.

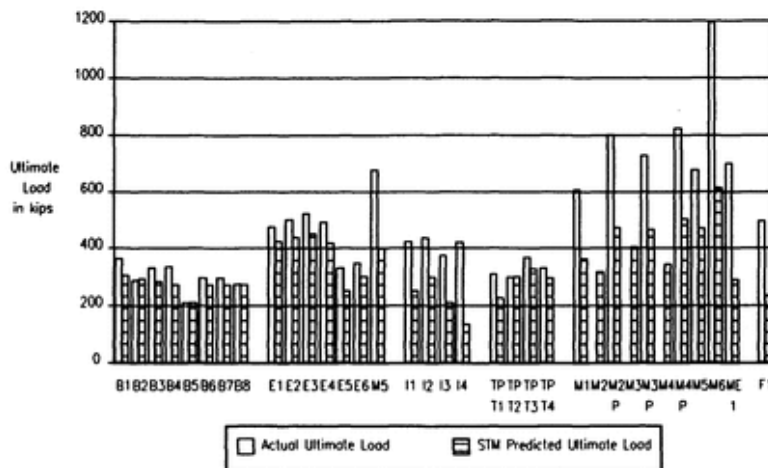

Figure 12: Actual Ultimate Load and Predicted Ultimate Load for Sanders' Test Specimens (1 kip = 4.54 kN)