

On Executable Meta-Languages applied to Model Transformations

Pierre-Alain Muller¹, Franck Fleurey¹, Didier Vojtisek¹, Zoé Drey¹, Damien Pollet¹,
Frédéric Fondement², Philippe Studer³ and Jean-Marc Jézéquel¹

¹ IRISA/INRIA, France {pamuller, ffleurey, dvojtisek, zdrey, dpollet, jmzequel}@irisa.fr

² EPFL/IC/UP-LGL, INJ, Switzerland, frederic.fondement@epfl.ch

³ MIPS, Université de Haute-Alsace, France, philippe.studer@uha.fr

Abstract. Domain specific languages for model transformation have recently generated significant interest in the model-driven engineering community. The adopted QVT specification has normalized some scheme of model transformation language; however several different model transformation language paradigms are likely to co-exist in the near future, ranging from imperative to declarative (including hybrid). It remains nevertheless questionable how model transformation specific languages compare to more general purpose languages, in terms of applicability, scalability and robustness. In this paper we report on our specific experience in applying an executable meta-language to the model transformation field.

1 Introduction

A DSL (Domain-Specific Language) is a specification or programming language which offers, through appropriate notations and abstractions, expressive power focused on, and usually restricted to, a particular problem domain.

Model transformation is a key facet of model-engineering, by which models which conform to some metamodels are translated into models which conform to some other metamodels. Technologies to perform model transformations range from conventional programming languages to specific transformation languages.

Domain specific languages for model transformation have recently generated significant interest in the model-driven engineering community. The OMG has adopted the QVT (Query, View, Transformation) specification, which normalizes some scheme of model transformation language.

However, many open issues about transformation languages still remain, and it is likely that several alternative paradigms (such as imperative, declarative or hybrid) will co-exist in the foreseeable future of model transformation languages.

From a software engineering point of view, it is highly desirable to gain a better understanding of how these various kinds of model transformation languages address

issues such as applicability, scalability and robustness. Indeed, there is not yet much practical experience with dedicated model transformation languages versus general purpose languages with respect to model transformations, and the optimal scope of domain specific transformation languages remains unclear. For instance, should these model transformation languages be limited to model manipulation in general and be associated to specific libraries, or should they emphasize a specific activity performed with models, such as transformation?

In this paper we report on our experience with executable meta-languages associated to specific frameworks to develop model transformations. Our experience is based on the development and use of three different imperative object-oriented languages for model manipulation, respectively: MTL a transformation language, Xion an action language and Kermeta an executable meta-language.

Although it has made this paper lengthy, we have decided to give substantial excerpts of the source code of the transformations, because we found it relevant in the context of a workshop dedicated to language comparison. Hopefully, the impatient reader may not have to browse through all these examples to understand our approach to model transformation, as we have motivated and summarized our position in the first sections of the paper. The complete sources of the examples can be found on <http://www.irisa.fr/triskell/Softwares/kermeta/examples/mtip>, from where the Kermeta Workbench can also be downloaded.

This paper is organized as follows: after this introduction, section 2 highlights the rationales for our work and examines some related works, section 3 presents the Xion, MTL and Kermeta languages, section 4 discusses model transformation design options with executable meta-languages, section 5 implements and discusses the workshop case-study, and finally section 6 (the conclusion) summarizes our position and outlines future directions.

2 Rationales for object-oriented executable meta-languages

In the model-driven engineering community, meta-languages such as MOF¹ are widely used to specify meta-models. The issue of persistence is well understood, and is achieved either via a serialization in XML (via XMI, for XML Metadata Interchange), or via direct storage in some database (e. g. MDR²).

Yet, existing meta-data languages (including MOF, EMOF¹, ECore³, MetaGME⁴), as their generic name suggests, are languages for defining data about data. Such data-driven languages focus on structural specifications and have no built-in support for the definition of behavior about these structures. There are mainly two options to work with the metamodels (and models) stored in the repositories:

- Using conventional programming languages, such as Java, via specific libraries which provide facilities to navigate, create, read or delete models and model elements.
- Using domain specific languages, such as action languages, constraint languages and transformation languages.

We believe that the rationale for the current separation between data and behavior specifications at the meta-meta level is mainly coincidental and results from the fact that research works in the field of model-driven engineering have been initially conducted by technical domains; mainly driven by functional user requirements, such as definition of actions, constraints and transformations, with little sharing beyond the data persistence level.

In our opinion, there is now enough understanding of these functional domains to initiate a convergence under the shape of some kind of common denominator of the fundamental current model-driven technologies, i.e. languages for meta-data definitions (such as MOF, EMOF, Ecore), model transformations (including MTL⁵ and ATL⁶, all more or less QVT⁷ compliant), constraint and query expressions (such as OCL⁸) and action specifications (such as the Action Semantics⁹, now integrated in UML 2.0).

We claim in this paper that a common kernel of language constructs can be defined to serve all purposes of model manipulations such as definition of metamodels and models, actions, queries, views and transformations. Moreover, making this kernel executable provides direct support to express the operational semantics of metamodels.

This kernel should contain basic instructions to define model structure and elements, manipulate the models and the model elements via fundamental *create*, *read*, *update* and *delete* operations, as well as iterators to navigate models or sets of model elements.

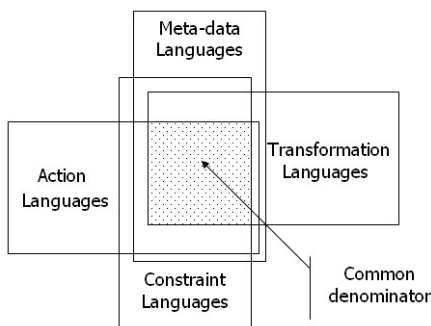

Figure 1: Meta-data, action, transformation and constraint languages share a common subset of language constructs.

2.1 Related works

Our work is related to many other works, and can be considered as some kind of synthesis of these works, in the specific context of model-driven engineering applied to language definition. The sections below include the major areas of related works.

Grammars, graphs and generic environment generators. Much of the concepts behind our work take their roots in the seminal work conducted in the late sixties on grammars and graphs and in the early eighties in the field of generic environment generators (such as Centaur¹⁰) that, when given the formal specification of a programming language (syntax and semantics), produce a language-specific environment. The generic environment generators sub-category has recently received significant industrial interest; this includes approaches such as Xactium¹¹, or Software Factories¹². Among these efforts, it is Xactium which comes closer to our work. The major differences are our adherence to OMG standards (such as EMOF) and the fact that we have a fully static type system.

Generative programming and domain-specific languages. Generative programming aims at modeling and implementing system families in such a way that a given system can be automatically generated from a specification written in a domain-specific language. This includes multi-purpose model-aware languages such as Xion or MTL⁵, or model transformation languages such as QVT⁷.

We share the vision of generative programming, and we use models to generate fully executable code which can be compiled. The Xion and MTL languages have had a direct impact on our work.

QVT is different as it addresses mappings between models. QVT works on structures, by specifying how one structure is mapped into another one; for instance translating a UML class diagram into a RDBMS schema. QVT is not suitable for the definition of the behavior of metamodels.

3 Overview of Xion, MTL and Kermeta

Xion and MTL are the ancestors of the Kermeta language. Xion is a platform independent action language which has been originally developed in the context of the Netsilon environment, for model-driven development of Web information systems¹³. MTL is an object-oriented model transformation language, which has been developed with software engineering concerns in mind, such as robustness, modularity and scalability. Interestingly, the two teams which have developed Xion and MTL independently have come to the same kind of conclusions. They have both developed a general-purpose, imperative, object-oriented language, with model-

navigation capabilities based on OCL, control structures such as found in Java or Eiffel, and with model management capabilities.

The lessons learned with Xion and MTL have shaped the requirements of Kermeta. Kermeta is a multi-faceted language. Kermeta is a small imperative object-oriented language, which is both an executable meta-language and a kernel upon which to build other languages (such as Xion or MTL which could be re-expressed in Kermeta). Although Kermeta is a small language, it provides high-level mechanisms such as static-typing, genericity and exceptions.

3.1 Xion

Xion is a general-purpose object-oriented action language, with special support for model manipulation, and automatic persistence of model elements. Xion is a platform-independent action language which abstracts away the details of data access, while being translatable into different target languages (such as PHP or Java).

Xion provides modeling concepts such as classes (with attributes, operations and methods), associations and aggregations, class-associations, and simple generalizations. Xion is a semi-graphical language, classes, attributes, operations and relations are defined via class diagrams; add- and remove-link operations are generated automatically. User-defined methods are specified in text.

In the context of this case study, Xion is used as an executable meta-language, in which case the metamodels are expressed in terms of classes and relations, in a manner very similar to what is done with MOF or ECore.

Xion provides support to query models and to express methods and state changes via an extension of the OCL *query expressions*. This means adding side-effects capability to OCL, and providing imperative constructs, such as blocks and control flows. Supporting side-effects means:

- create and delete an object,
- change an attribute value,
- create and delete links,
- change a variable value,
- call non-query operations.

It was also necessary to remove some constructs of the OCL, which are out of the scope of our approach:

- context declaration, only useful for defining constraints,
- @pre operator and message management, only meaningful in the context of an operation post-condition,
- state machine querying.

Since most developers are already familiar with the Java language, we re-used part of its concrete syntax. Constructs we took from Java are:

- instruction blocks, i.e. sequences of expressions,
- control flow (if, while, do, for),
- return statement for exiting an operation possibly sending a value,
- “super” initializer for constructors.

Moreover, for Xion to look like Java as much as possible we decided to keep Java variable declaration, and operators (`==`, `!=`, `+=`, `>>`, `?` ternary operator, etc.) rather than those defined by OCL. The standard OCL library was also slightly extended, by adding the `Double`, `Float`, `Long`, `Int`, `Short` and `Byte` primitive types, whose size is clearly defined unlike the OCL `Integer` or `Real`. As applications often deal with time, we have also added the `Date` and `Time` predefined types. An exhaustive presentation of the language is given in the help of the Netsilon tool.

3.2 MTL

MTL (Model Transformation Language) is an imperative object-oriented language, which has been developed to experiment with new ideas in the context of the MOF QVT normalization process, and to make sure that research concerns will be taken into account.

MTL shares much of the description of Xion given beyond, in terms of abstract (and even concrete) syntax. A major difference is the requirement of MTL to be tool independent. Whereas Xion was emphasizing automatic object persistence, MTL seeks model (and metamodel) representation independence, and can interact in a unified way with various model repositories such as MDR (MetaData Repository, Sun), ModFact¹⁴ (Lip6) and EMF (Eclipse Modeling Framework, IBM). For instance, a MTL transformation written for a given model, can then be applied to that model independently of the language (say MOF or ECore) used to express the metamodel of that given model. As a central tool, MTL helps investigate and federate different research areas and tools related to model transformation which share common concepts: models and meta-models.

MTL was designed with strong software engineering concerns in mind, such as scalability and robustness. As model transformations may become quite complex, the transformation developers should be able to re-use popular know-how and best practices of software engineering. In other words, the transformation must be designed, modelled, tested and so forth. The MTL language therefore uses an object-oriented style similar to popular languages like Java and C#. One of the special features is that elements of the models and classes of the language are manipulated in a consistent way. There is no difference between navigating or modifying a model and using transformation classes; for instance, both use the concepts of class, attribute, association, etc. Best practices obviously include the ability to apply the

MDE approach to the transformations themselves. This is done within MTL with a bootstrap process: the components of the transformation engine are written using the engine itself.

MTL is distributed as open-source software. Technically, its user interface is based on a plug-in within Eclipse which provides a dedicated editor for the textual syntax of MTL, an execution environment and an outline view.

3.3 Kermeta

Kermeta has been designed to be the core language of a model-oriented platform¹⁵. Kermeta, as shown in Figure 1, can be considered as a common denominator of several model-oriented technologies.

Kermeta consists of an extension to the Essential Meta-Object Facilities (EMOF) 2.0¹ to support behavior definition. It provides an action language to specify the body of operations in metamodels. The action language of Kermeta is imperative and object-oriented.

Kermeta has been defined based on the experience of two existing languages Xion and MTL. Xion is an action language for UML class diagrams; it is used to provide a high level platform independent implementation of operations and methods. The Netsilon tool is used to generate either java or PHP code from Xion code.

MTL (Model Transformation Language) is an object-oriented model transformation language. It provides APIs to allow manipulating models from various repositories (Eclipse EMF, Netbeans MDR...) in a unified manner.

Xion and MTL have been designed for different purposes but they share many constructions such as expression for querying model or CRUD operations on objects. Kermeta is mainly an object-oriented language which includes features such as multiple inheritance, operation redefinition, class genericity and dynamic binding. However, for model processing, specific construction were added to handle model specific features such as associations and object containment. In addition to these, and for usability purposes, convenient model navigation expressions such as OCL iterators (select, collect, reject...) have been added. The resulting language is fully statically typed to ensure strong reliability concerns.

The Kermeta platform is developed at INRIA as an open-source project¹⁶. It currently includes a parser, a type-checker and an interpreter. It is distributed as an Eclipse plug-in which includes an editor for Kermeta programs with syntax coloring and code completion capabilities. In addition the platform includes libraries to load and store models from the Eclipse Modeling Framework and to import ECore metamodels.

4 Discussion

In this section, we will cover the points of discussion that were listed in the call for papers, and some others that we find relevant in the context of Kermeta.

Object-orientation

Kermeta is an object-oriented language, which provide support for classes and relations, multiple inheritance, late binding, static typing, class genericity, exception, typed function objects... The object-oriented nature of Kermeta has a double origin. First, as for Xion which is based on UML, the structural part of the Kermeta language is based on an object-oriented meta-data language (EMOF). Next, as for MTL, there is a strong requirement for Kermeta to support software engineering good-practices such as modularity, testability and reuse, which are well supported by object-orientation.

The refactorings optional part of the case study is a good example of how object-oriented techniques, such as patterns, may be applied to model transformations. The Kermeta implementation shows the use of a command patterns to apply a transformation. Interestingly, this also provide an example of doing and undoing a transformation.

Finally, object-orientation eases the learning of the new language, as many developers are used to that paradigm, and can immediately apply their programming skills in the context of model transformation.

Composition of transformations

Kermeta provides packages, classes, operations and methods, inheritance and late bindings. All these features can be used to encapsulate transformations. Composition of transformations can be achieved in several ways, for instance by operations calls or method overloading. Rule recursivity is handled by function recursivity.

Robustness and error handling.

Reliability is a major concern in the design of Kermeta. The language is statically typed, and the code can be fully checked for correctness at compilation time. For unexpected behavior at runtime, the language provides exception handling.

Debugging support

The debugger is under development. This is not part of the language itself, but of the Kermeta Workbench. In the meantime, traces are used to help solving problems in the transformation code.

Flexibility, overall usability and power of the chosen approach

To our opinion, Kermeta is currently a very good compromise between a general-purpose language such as Java, and a specific model transformation language such as specified by QVT. The implementation of the workshop case study, given below, proves that the language is usable for model transformation, and also that it can handle all kinds of transformations (either specified via mappings as for the class to RDBMS example, or via algorithms as for the determinization/minimization of automata).

Whether the approach can express bidirectional and / or incremental (sometimes known as change propagating) transformations

This is really a matter of programming. The Arabic and Roman numbers, and the refactorings, are examples of bidirectional, and change propagating transformations.

Technical aspects such as the ability to deal with model exchange formats, modeling tool APIs, and layout updates

Kermeta is fully compatible with ECore. The structural part of Kermeta is compliant to ECore, and the behavioral part is expressed as an ECore metamodel. Thus, any tool compatible with ECore is compatible with Kermeta. Kermeta can read and write ECore files to load and save models. The Kermeta workbench is available as an Eclipse plugin.

General purpose language vs. model transformation language

Kermeta has nothing specific to model transformation, but being quite general purpose, it can be used to implement mechanisms to support model transformations. As with general-purpose languages such as Java, specific support (for instance for transformations triggering, trace and debugging) is added via libraries and frameworks. This gives extensive expression freedom to the developer to write the transformations.

For instance, in the class to RDBMS example, information has to be stored in one pass to be used in another one. The Xion example also shows how part of the transformation are queued and triggered later on by other parts, for instance to query the target model when transforming the associations.

However, there is a wide variety of potential design choices depending on the transformation developer's needs, such as the usual trade-offs between complexity optimization and memory optimization. This implies that the transformation language must be generic enough to take into account the various needs of the developers.

Design variations, libraries vs. DSLs

Writing a transformation can be done in many different ways. A final design reflects a set of tradeoffs made by the developer. The variation of the designs may be more or less constrained by the amount of pre-design and reuse provided by the language environment. Libraries and frameworks can be used to provide specific capabilities, such as traceability or information storage about the transformation process itself.

Such pre-design decisions can be captured either in libraries or in the language itself, and this is the difference between libraries for general purpose languages, and DSLs.

Kermeta has precisely been built to facilitate such transition, when the domain knowledge is such that it is worth to embed this knowledge directly in a dedicated language. Our position is similar to D. Roberts and R. Johnson¹⁷ who state that a prerequisite to developing a DSL is mature domain knowledge. Kermeta can be used to represent the abstract syntax of languages, under the shape of metamodels. Then, Kermeta being executable, the operational semantic of these languages can be further specified in Kermeta, reusing the library code which was previously developed.

Software engineering concerns

Since model transformation may become quite complex, we believe that transformation developers need to re-use popular know-how and best practices in software engineering. Kermeta provides language support for modularity in the small (classes) and the large (packages), reliability (static typing, typed function objects and exception handling), extensibility and reuse (inheritance, late binding and genericity).

Future work

Maintaining consistency of the relations between transformations is a real challenge and requires dedicated language and tool support. Requirements include:

- application of design patterns
- development of helper frameworks
- support of the Design by Contract approach
- weaving of modelling aspects
- derivation of products from product lines
- code generation
- simulation of functional and extra-functional features of a system
- derivation of state charts from HMSC (High-Level Message Sequence Chart, the basis of UML2.0 sequence diagrams)
- synthesising test cases from UML models

5 MTIP workshop case studies

This section presents the transformations that we have written to implement the requirements of the MTIP workshop case study. Sub-sections 5.1, 5.2 and 5.3 present the mandatory transformations, respectively in Xion, MTL and Kermeta, then section 5.4 shows the optional example of Roman and Arabic numbers in Kermeta, section 5.5 gives an example of refactoring written in Kermeta, and finally section 5.6 presents the determinization and minimization of automata in Kermeta.

5.1 Mapping classes to tables in Xion

The following metamodels are part of the MTIP case study. They have been represented visually with the Netsilon class diagram editor. Figure 2 and Figure 3 show respectively the source and target metamodels of the MTIP workshop case study. Notice that various operations have been added to the classes. Adding these operations directly in the classes is questionable. On one hand, it promotes encapsulation and gives an object-oriented flavor to the transformation; on the other hand it establishes some coupling between the static aspect of the metamodel and a specific transformation. Whether this is good or bad depends heavily on the context; in this example in Xion we chose the former option. In the following example in Kermeta we will choose the latter.

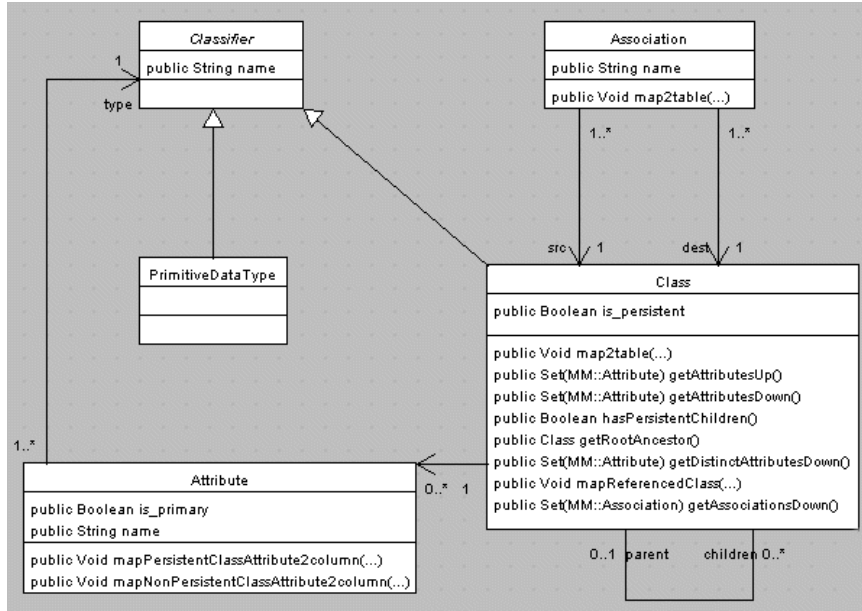

Figure 2: Source metamodel expressed in Xion.

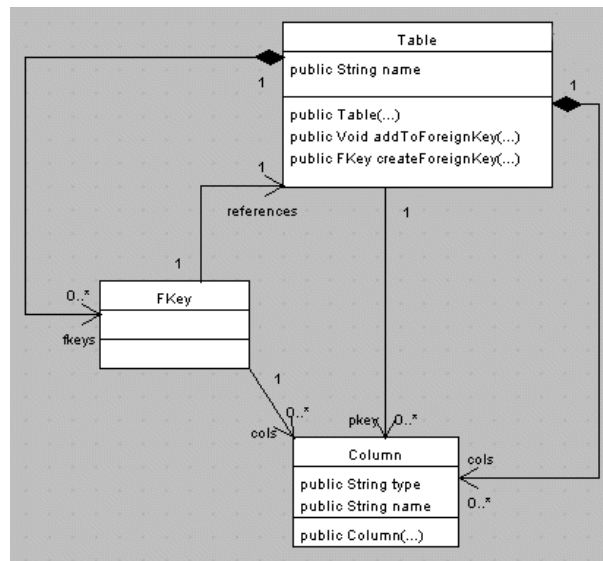

Figure 3: Target metamodel expressed in Xion.

In addition to the classes defined in the case study, we have also defined two utility classes `Transformation` and `ClassTransformation`, to store information about the transformation process itself.

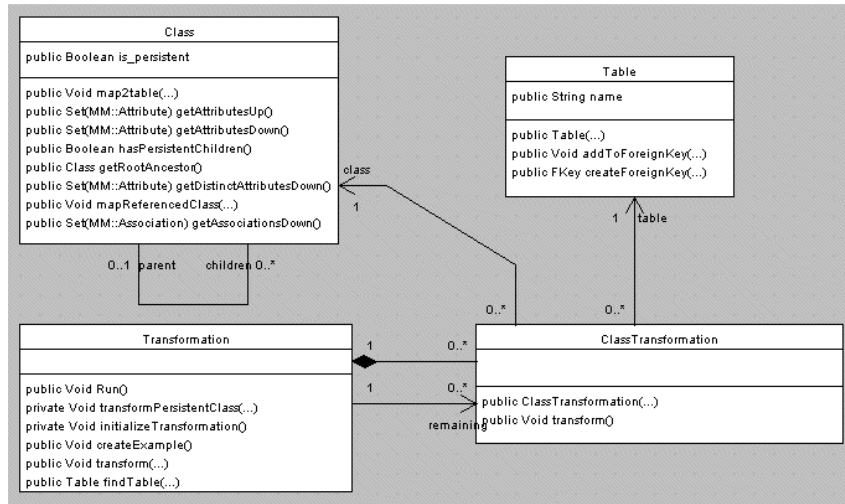

Figure 4: Specific Xion classes to support transformations.

The transformation process (initiated when the `Run` method of the `Transformation` class is invoked) first traverses all the classes in the source model, and creates a `ClassTransformation` instance (a pair `Class`, `Table`) for each class which has to be made persistent. In a second step, the `Transform` method of class `ClassTransformation` creates the columns required to ensure persistence of all the attributes and relations present in the source model.

Transformation Class

The `Transformation` class contains the top-level transformation methods. The process of transformation starts when the `Run` method is invoked.

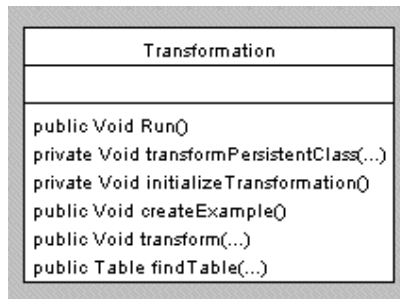

Figure 5: Specification of the Transformation Class.

For all class hierarchy which contain persistent classes, a table is created for the root class. The `allInstances` operation retrieves the collection of all the instances of the `Class` class. Xion is a persistent language; all the instances are automatically stored in permanent storage.

The following Xion expression, creates a table for all topmost classes which are either persistent, or have at least one persistent subclass. All the metamodel classes are defined in a package named `MM` (for metamodel).

```
public Void Transformation::Run (Class class, Table table) {
  MM::Class.allInstances()
  ->select (parent == null)
  ->select (c : c.is_persistent || c.hasPersistentChildren())
  ->collect (c : transformPersistentClass(c));

  this.classTransformation->collect (t : t.transform());
}

with

private Void Transformation::transformPersistentClass (Class class) {
  MM::ClassTransformation t =
    new MM::ClassTransformation(class, new MM::Table(class.name));

  this.addClassTransformation(t);
  this.addremaining(t);
}
```

Class Class

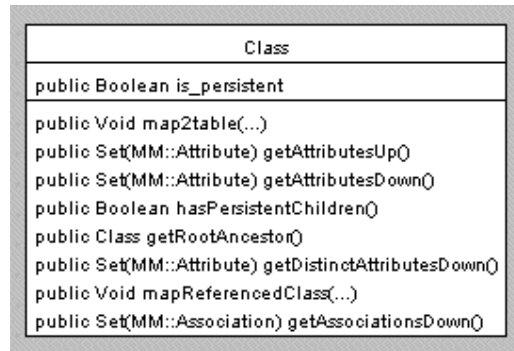

Figure 6: Specification of the Class Class.

Rule 6 states that attributes in subclasses with the same name as an attribute in a parent class are considered to override the parent attribute. The operation `getDistinctAttributesDown` builds the set of attributes within a class hierarchy, while removing those overridden in subclasses. The operation starts from a root class, and then collects recursively down the attributes defined in subclasses.

```

public Set (MM::Attribute) Class::getDistinctAttributesDown () {
  if (this.children == null)
    return this.attribute;

  Set (MM::Attribute) children =
    this.children.getDistinctAttributesDown()->asSet ();

  return this.attribute
    ->select(a : !children->exists(c : c.name == a.name))
    ->union(children);
}

```

According to the CFP, there is not association overriding.

```

Public Set (MM::Association) Class::getAssociationsDown() {
  Set (MM::Association) associations =
    MM::Association.allInstances()->select(a : a.src == this);

  if (this.children == null)
    return associations;
  else
    return associations
      ->union(this.children.getAssociationsDown()->asSet ());
}

```

Rule 6 states that when transforming a class, all attributes of its parent class (which must be recursively calculated), and all associations which have such classes as a src, should be considered.

Attributes in subclasses with the same name as an attribute in a parent class are considered to override the parent attribute.

```

public Void Class::map2table (Table t, Transformation transformation)
{
  self.getDistinctAttributesDown().mapPersistentClassAttribute2column
    (this, t, transformation);

  this.getAssociationsDown().map2table(this, t, transformation);
}

public Void Class::mapReferencedClass( Class sourceClass,
                                       Table sourceTable,
                                       String namespace,
                                       Transformation transformation)
{
  // Be sure that the attributes have already been transformed
  transformation.transform(this);

  // 2. Classes that are marked as non-persistent should not be
  // transformed at the top level.
  if (!this.is_persistent) {
    this.attribute
      ->collect(a : a.mapNonPersistentClassAttribute2Column
                (sourceClass, sourceTable, namespace));
  }
  else{
    // Retrieve primary attributes
    MM::Table table = transformation.findTable(this);
  }
}

```

```

Sequence(MM::Column) columns = table.pkey->asSequence();

if (columns->size() > 0) {
  MM::FKey fkey = sourceTable.createForeignKey(table);
  for (Integer i = 0; i < columns->size(); i++) {
    sourceTable.addToForeignKey(fkey,
      new MM::Column (namespace + "_" +
        columns->at(i).name,
        columns->at(i).type));
  }
}

```

Attribute class

Two operations have been added to the Attribute class. These operations are responsible for mapping an attribute to a column.

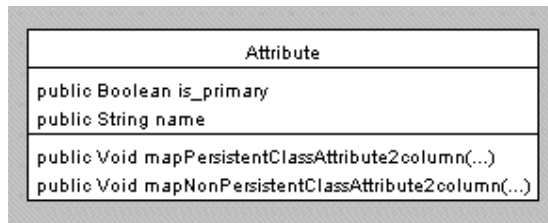

Figure 7: Specification of Attribute class.

The `mapNonPersistentAttribute2Column` operation is partially implemented. In the case of a primitive type, a column is created, with renaming, and primary key property if required. Other cases would store information about attributes and associated columns, and were not implemented, for lack of time resource.

```

Void Attribute::mapNonPersistentAttribute2Column(Class sourceClass,
Table sourceTable, String namespace){
  if (self.type.oclIsTypeOf(MM::PrimitiveDataType))
  {
    // Rule 3
    // Attributes whose type is a primitive type should be transformed
    // to a single column whose type is the same as the primitive type

    MM::Column column = new MM::Column (namespace + "_" + self.name,
      self.type.name);

    sourceTable.addcols(column);

    if (self.is_primary)
      sourceTable.addpkey(column);
  }
  else if (self.type.oclAsType(MM::Class).is_persistent){
    // To Do
  }
  else if (self.type.oclAsType(MM::Class).is_persistent == false){
    // To Do
  }
}

```



```

else{
  // should raise an error
}
}

Void Attribute::mapPersistentClassAttribute2Column
(Class class,
 Table t,
 Transformation transformation)
{
  if (self.type.ocIsTypeOf(MM::PrimitiveDataType)){
    // Rule 3
    // Attributes whose type is a primitive type should be
    // transformed to a single column whose type is the same as the
    // primitive type

    MM::Column column = new MM::Column (self.name, self.type.name);
    t.addcols(column);
    if (self.is_primary)
      t.addpkey(column);
  }

  else if (self.type.ocIsType(MM::Class).is_persistent){
    // Rule 4
    // Attributes whose type is a persistent class should be
    // transformed to one or more columns, which should be created
    // from the persistent classes' primary key attributes.
    // The column should be named name_transformed_attr where name
    // is the attributes' name.
    // The resultant columns should be marked as constituting a
    // foreign key; the FKKey element created should refer to the
    // table created from the persistent class

    MM::FKKey fk = t.createForeignKey(MM::Table.allInstances()
->select
  this.type.ocIsType(MM::Class).getRootAncestor().name ==
  name)->getOne());

    self.type.ocIsType(MM::Class).getAttributesUp()
->select(is_primary)
->collect(pk : t.addToForeignKey(fk,
  new MM::Column
    (pk.name+"_transformed_attr",
    pk.type.name)));
  }

  else if (self.type.ocIsType(MM::Class).is_persistent == false){
    // Rule 5
    // Attributes whose type is a non-persistent class should be
    // transformed to one or more columns, as per rule 2.
    // Note that primary keys and foreign keys of the translated
    // non-persistent class need to be merged into the appropriate
    // table

    self.type.ocIsType(MM::Class).mapReferencedClass(class,
      t,
      name,
      transformation);
  }

  else{
    // should raise an error
  }
}

```

5.2 Mapping classes to tables in MTL

This section presents some of the various techniques used to implement the ‘class to RDBMS’ example with MTL. As the reader will discover, these techniques are usually well known or simple. The relevance in the scope of this workshop is not to do a precise description of each of them but to consider their simultaneous use in order to solve model transformation problems. The reader interested in the concrete code can find an excerpt of the code in annex and the complete source of the transformation on the MTL web site¹⁸. The global architecture for the implementation of the model transformation sample is organized around two passes into a visitor pattern¹⁹. It is supported by a small framework and the use of some intermediate structures. The interested reader will find the complete transformation on the MTL web site; <http://modelware.inria.fr/article71.html>

Visitor

The visitor pattern provides an easy way to traverse a model. Several points may be tuned when using visitors, as a base, the visitor allows to call specific operations depending on the type of the traversed elements. Another variation point may be obtained by defining the traversal order. The inheritance notion of the object oriented language is then a simple way to profit of existing visitors.

Depending on how the metamodel has been designed, one can generate some default visitors that provide a generic traverse order. These default visitors are usually based on the composition relations in the metamodel. This kind of visitor is useful as it ensures that the model elements are traversed only once. However, in our sample, none of the metamodels use the composition. We choose to not change the metamodel of the sample because in practice the transformation developer may not have the opportunity to do so even if it would be simpler for him. In this situation, as we cannot use the default visitor, we provided an ad-hoc one which provides the same property.

Moreover, MTL has some special aptitude with visitors. It automatically adds the needed *accept(visitor)* method to any model element or MTL class. Then, writing or generating a visitor is quite straightforward.

The following code excerpt presents `visitClass` method of the `ClassVisitor` Class.

```
Class ClassVisitor
visitClass (instance : Standard::OclAny; context : Standard::OclAny)
  : Standard::OclAny
{
  theClass      : source_model::Class;
  result        : VisitorResult;

  // we create the result
  result := resultFactory.create (); // we retrieve the called object
```

```

theClass := instance.oclAsType (!source_model::Class!);
// we continue the visit with the Attribute objects
foreach (anAttribute : source_model::Attribute) in (theClass.attrs)
{
    result.add(anAttribute.accept (this,
                                context).oclAsType(!Standard::OclAny!));
}
// this would have been better if the association has been
// navigable from the class.
// as the metamodel is not navigable this way, we have to retrieve
// it using a foreach on the type.

foreach (anAssociation : source_model::Association) in
    (!source_model::Association!.allInstances()){
    if( anAssociation.src.[=](theClass))
    { // visit only association for which this class is source
      // (ensures that we visit only once)
      result.add (anAssociation.accept (this,
                                       context).oclAsType(!Standard::OclAny!));
    }
}
return result;
}

```

Multipass

One of the difficulties a transformation writer may encounter is about the appropriate time to apply some parts of the transformation. In fact, when writing the specification of the transformation, it looks like a set of rules that doesn't take care if the elements it refers to already exist or not. The transformation writer has to ensure that an element has been created before linking it. For the case study sample, we have split the actions in two sets, each of them launched from a visitor. Then, the transformation is applied in two passes. The first pass creates all the main elements in the target model. It also links some of those elements, but only if the traverses order of the visitor ensures that the linked elements exist. Now, certain that all the elements exist, the next pass is free to apply any remaining rule. In order to clarify the code, the transformation writer, may choose to use more than two passes and then group the execution rules. Splitting the transformation into several passes also helps in writing and debugging the transformation as it is possible to visualize the intermediate results, considering each pass as an independent transformation.

In the case of our sample, the first pass creates all the tables and the columns accessible via the primary key link. The second pass creates the remaining columns and links. As an illustration, the MTL code of the first pass is given below.

```

visitClass (instance : Standard::OclAny; context : Standard::OclAny)
    : Standard::OclAny
{
    theClass : source_model::Class;
    result : VisitorResult;
    str : Standard::String;
    theTable : target_model::Table;

    // we create a new visitor result
    result := this.resultFactory.create ();
    // we retrieve the called object
    theClass := instance.oclAsType (!source_model::Class!);
}

```

```

// if persistent create a table
if classHelper.isClassPersistent(theClass)
{
    // if this is the topmost parent then create the class
    // otherwise , simply retrieve the table
    if isNull(theClass.parent)
    {
        // create the table
        theTable := class2RDBMSHelper.getTableForClass(theClass);
    }
    else
    {
        theTable := class2RDBMSHelper.getTableForClass(
            classHelper.getTopParent(theClass));
        trace.add(theClass, theTable);
    }

    // we call the parent visit method,
    // the current class is passed in the context
    this.oclAsType(!ClassVisitor!).visitClass(instance, instance);
}
/* else: non persistent classes, connected attributes
and associations cannot be processed in pass 1 */

return result;
}

```

Splitting the transformation also allows using the clearest and most efficient data source for the implementation of the rules. The main logic of the transformation may rely on the source model, on the target model, or both. MTL by itself doesn't presuppose the transformation to use any of them. In fact, in our implementation, we have used model elements from both the input and the output model. This is because we favour the clearest algorithm as it will help for maintenance.

In pass1, we clearly use the source model because we are creating the target elements. Moreover, even if we had an existing target model to synchronize with, we cannot rely on its completeness and integrity during this phase.

In pass2, the scheme is slightly different; we already have a reliable intermediate model in the target model. Then, if the information in the target model is more expressive than the information in the source model, it would be painful to restrict the transformation writer to the source only. We have used such information while creating the non primary columns. Thanks to pass1, we already have the names of the primary key columns we want to refer with the foreign key. As we also have gathered the path between the source and target classes thanks to the intermediate structure described more in detail two sections below. With that information, the task is then straightforward.

Framework

To help writing the rules of the transformation in the visitor passes, we use a small framework. Typically, it contains reusable code like queries, creations or complex algorithms.

In our context, we can distinguish two main kinds of frameworks: metamodel oriented frameworks and transformation oriented frameworks.

The metamodel oriented frameworks are dedicated to only one metamodel, such as UML, or our case study class metamodel or RDBMS metamodel. Each time we use a new metamodel, we may need to develop such framework. Even for simple metamodels, we may need to repeat some complex requests. For example in the class metamodel, asking for the persistence of a class seems obvious, but as explained in the Frequently Asked Questions of the workshop site, this is in fact recursive. Asking for the persistency implies to navigate the parent link up to the topmost parent to be able to answer. In this way, some of the complexity of a simple metamodel may be hidden in the algorithm of an apparently simple request. Another extreme sample is the node and edge metamodel; it is very powerful, but will require much more helper methods to make it useable for simple queries than a dedicated metamodel. The variety of helper methods of such framework is quite vast and depends on the use of this metamodel.

The transformation oriented frameworks are related to a given transformation. Sometimes, they may be considered as part of the transformation itself. However, as more and more transformations are developed, the method which has initially been designed for a given transformation would be useful in another one. For example, one can think to have two variants of the 'class to RDBMS' transformations: one that take only a class model as source, one that takes a class model and another configuration model. Both transformations are relevant, and they can share code through this sort of framework.

The frameworks are useful to capitalize on know how and complex algorithms. Typically, some of the recursive queries implied by the case study fit in one of those frameworks.

We present below, two methods to create attributes, excerpted of our Class2RDBMS framework.

```
// add the created columns to the table
// use the given prefix for column name
createColumnsForNonPersistentClass(
    theClass: source_model::Class;
    theTable : target_model::Table;
    namePrefix : Standard::String)
{
    newPrefix : Standard::String;

    foreach ( anAttribute : source_model::Attribute)
        in (theClass.attrs)
    {
        newPrefix := namePrefix;
        createColumnFromAttribute(anAttribute, theTable, newPrefix);
    }

    foreach ( anAssoc : source_model::Association)
        in (classHelper.getDestAssoc(theClass))
    {
        if not classHelper.isClassPersistent(
            anAssoc.dest.oclAsType(!source_model::Class!))
        {
            newPrefix := namePrefix.concat(
                anAssoc.name.oclAsType(!Standard::String!));
            createColumnsForNonPersistentClass(
                anAssoc.dest.oclAsType(!source_model::Class!),
```

```

        theTable,
        newPrefix);
    }
}

createColumnFromAttribute(theAttribute: source_model::Attribute;
    theTable : target_model::Table;
    namePrefix : Standard::String) :
target_model::Column
{
    theColumn : target_model::Column;
    name      : Standard::String;

    name := namePrefix.concat (
        theAttribute.name.oclAsType(!Standard::String!));

    if
    (theAttribute.type.oclIsKindOf(!source_model::PrimitiveDataType!))
    {
        theColumn := new target_model::Column();
        theColumn.name := name;
        theColumn.type := theAttribute.type.name;

        associate (cols := theColumn : target_model::Column,
            owner := theTable : target_model::Table );
        if theAttribute.is_primary
        { // we also need to associate it as a pkey
            associate (pkey := theColumn : target_model::Column,
                pkeyreferers:= theTable :
target_model::Table );
        }
    }
    return theColumn;
}

```

Trace metamodel and internal transient data structures

In order to ease the transformations in the second pass we also use a separate structure, a small trace model. For all the main elements in the source model, this trace model stores the target element created during the first pass. Then during the following passes, a query on the traces retrieves the elements, the source or the target depending on the need. As the traces allow retrieving the context of the previous pass, writing the rules of the following passes is easier.

In addition to the internal usage, these traces, exposed as a model, can also be saved for use by a following transformation or a reverse transformation.

Sometimes, some rules imply to construct intermediate data. Typically, a query will ask for all the elements that match given criteria. The result will be a set of those elements which can be processed later. As the set is a structure defined by the MOF, this is natural to use it for that purpose. However, in some case we may need more sophisticated structures.

For example, in the second pass of the 'class to RDBMS' sample, we want to create the foreign key and the columns in the source classes pointing to a persistent target class. To achieve that we need to retrieve all the persistent classes associated as a

source to the given class. A recursive method will easily create such a list, even if there are several non persistent classes between persistent source classes and persistent target classes in the association graph. If we follow this simple approach, we still lack some information in order to create the columns. We need their names, and the names depend of the association path between the persistent source classes and their persistent targets. The simple set of Class is not enough here; we need to add some more information along to the Class. A new internal structure will tackle that, it defines a new MTL class that stores a persistent class and the path that lead to that class. Then from this list, we have enough information to create the foreign key and the columns in the source classes.

5.3 Mapping classes to tables in Kermeta

This section details step by step the implementation of the mandatory model transformation for the workshop in Kermeta.

The metamodels

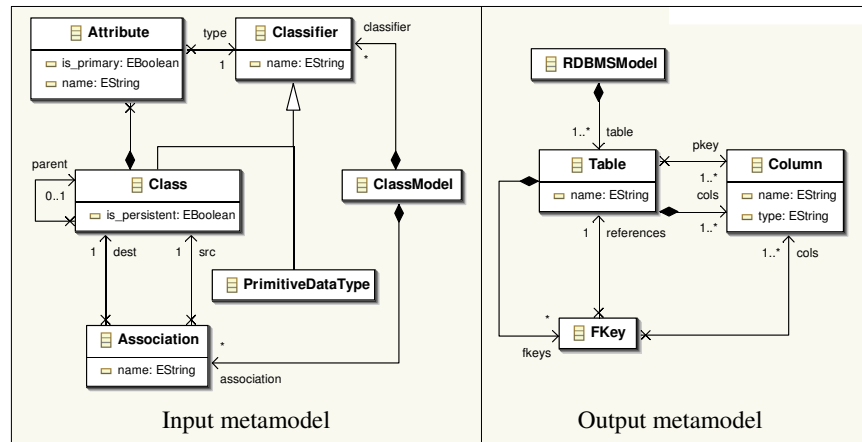

Figure 8: Input and output metamodels expressed in Kermeta visual syntax

Within the Kermeta environment, the first step for implementing a model transformation is to provide the input and output metamodels. As Kermeta relies on the Eclipse Modeling Framework (EMF) for model storage, regular EMF metamodels can be used: ECore files. These metamodels can be created and edited using the generic model editor provided with the EMF. The Omondo UML tool²⁰ provides a graphical editor for ECore metamodels. Figure 1 displays the Class metamodel and the Database metamodel as it has been defined using Omondo UML.

There are two different ways of using an ECore metamodel in a Kermeta program.

- This first is to import directly the ECore metamodel in the Kermeta program. This is the simplest manner as it provides the ability to manipulate in Kermeta instances of the classes of the metamodel.
- The second possibility is to generate from the ECore file the metamodel in Kermeta. This is especially useful to add behaviors to the metamodel, which is one of the key features of Kermeta.

For the implementation of the `Class2RDBMS` transformation we have chosen, in order to present the two approaches, to use the input metamodel directly and to generate the Kermeta metamodel for the RDBMS metamodel. Figure 9 presents the Kermeta code generated from the RDBMS metamodel.

```

package RDBMSMM;

require kermeta
using kermeta::standard

class Table
{
    attribute name : String
    attribute cols : Column[1..*]
    reference pkey : Column[1..*]
    attribute fkeys : FKey[0..*]
}
class FKey
{
    reference references : Table
    reference cols : Column[1..*]
}
class Column
{
    attribute name : String
    attribute type : String
}
class RDBMSModel
{
    attribute table : Table[1..*]
}

```

Figure 9: RDBMS metamodels expressed in Kermeta text.

Design of the transformation

Once the metamodels for the inputs and outputs of the transformation are provided, the next step is, as for any software development, to design the transformation. The design stage is more important here, as we use a general-purpose language, than if we were using a language dedicated to model transformation.

In effect, a formalism dedicated to model transformation would provide specific ways of writing transformation where as with Kermeta the transformation is simply an object-oriented program that manipulates model elements.

The proposed transformation generates tables from classes marked persistent. For attributes and associations in these classes it generates columns and foreign keys in the tables. The transformation can be implemented in three steps:

- Create tables. Tables are created from each class marked persistent in the input model.
- Create columns. For each persistent class process all attributes and outgoing associations to create corresponding columns. The foreign keys are created but the *cols* property cannot be filled and the corresponding columns cannot be created because primary keys of *references* table cannot be known before it has been processed.
- Update foreign-keys. The foreign-key columns are created in the table that contains the foreign-key and the property *cols* of foreign-keys is updated.

Between step 1 and 2 a trace information should be kept between persistent classes and created tables. Keep mappings from source objects and target objects is a general model transformation need. In Kermeta this can be done using several techniques. The first is to use an ad-hoc data structure such as a *Map* to store the correspondence. This would be the simplest solution but as traceability is a common feature to model transformations, it might be interesting to design a reusable solution to handle management of trace information. Kermeta provide for such purposes facilities such as generic classes and operations in order to make the reuse of generic frameworks safe and easy.

Figure 10 presents the implementation of a very simple reusable trace utility. It can be used to represent a one to one mapping between two types of objects. In the implementation of the `Class2RDBMS` transformation we will use it to store the mapping between persistent classes and generated tables. The *Trace* class is defined as a generic class with two type parameters *SRC* and *DST* that should be bound with the type of the source and target objects. The implementation of the class is very simple and consists of using a *Hashtable* (available from the Kermeta standard library) to store the mapping between objects.

This simple traceability capability is enough for the implementation of the `class2RDBMS` case study but in practice the traceability framework should be enriched to adapt to most model transformation issues. We have already identified several needs for such a framework such as the ability to store bi-directional mappings, one to many or many to many mappings. In addition to the problem of storing object mappings, traces for transformations from model to text or text to model should also be taken into account.

```

package trace;

require kermeta
using kermeta::utils

/**
 * This class represents a simple one to one
 * unidirectional mapping
 */
class Trace<SRC, TGT>
{
    /** Mapping between source and target objects */
    reference src2tgt : Hashtable<SRC, TGT>

    operation create() is do
        src2tgt := Hashtable<SRC, TGT>.new
    end

    /** get a target element */
    operation getTargetElem(src : SRC) : TGT is do
        result := src2tgt.getValue(src)
    end

    /** Store a trace */
    operation storeTrace(src : SRC, tgt : TGT) is do
        src2tgt.put(src, tgt)
    end
}

```

Figure 10: Very simple traceability framework.

Another design issues when writing a model transformation in Kermeta is how the code of the transformation is encapsulated. One of the important feature of Kermeta is to allow adding code directly in metamodels. This is especially interesting to allow sharing queries and common behaviors between several transformations that operates on the same metamodel. However, non-reusable transformation specific features should not be added to the metamodel. To do so, transformation specific classes can be defined directly in Kermeta to contain the implementation of the transformation. Traditional OO design techniques should be used to design these classes.

As the Class2RDBMS example is pretty simple, we have chosen to implement it in a Class2RDBMS class and to include a helper method in the RDBMS metamodel to handle the proper creation of foreign-keys (step 3 of the algorithm). As a result, the Class2RDBMS contains a few query methods on class model that could have been integrated in the Class metamodel to be reused by other transformations. The next section details the implementation of the transformation.

Implementation of the transformation

The transformation has been implemented in a class named *Class2RDBMS*. This class provides a method *transform* that takes the input model as a parameter and

returns the corresponding output model. Figure 4 presents an excerpt of the Kermeta code of the transformation.

```

package Class2RDBMS;

require kermeta // The kermeta standard library
require "trace.kmt" // The trace framework
require "../metamodels/ClassMM.ecore" // Input metamodel in.ecore
require "../metamodels/RDBMSMM.kmt" // Output metamodel in kermeta

[...]

class Class2RDBMS
{
  /** The trace of the transformation */
  reference class2table : Trace<Class, Table>
  /** Set of keys of the output model */
  reference fkeys : Collection<FKKey>

  operation transform(inputModel : ClassModel) : RDBMSModel is do
  // Initialize the trace
  class2table := Trace<Class, Table>.new
  class2table.create
  fkeys := Set<FKKey>.new
  result := RDBMSModel.new
  // Create tables
  getAllClasses(inputModel).select{ c | c.is_persistent }.each{ c |
    var table : Table init Table.new
    table.name := c.name
    class2table.storeTrace(c, table)
    result.table.add(table)
  }
  // Create columns
  getAllClasses(inputModel).select{ c | c.is_persistent }.each{ c |
    createColumns(class2table.getTargetElem(c), c, "")
  }
  // Create foreign keys
  fkeys.each{ k | k.createFKKeyColumns }

  end

  [...]
}

```

Figure 11: The three steps of the transformation

The three steps of the transformation clearly appear in the body of operation transform. First, classes are created for each persistent class, second columns are created in the tables and finally the foreign keys are updated. The mapping between classes and tables is represented by the reference *class2table* in class *Class2RDBMS*. The *fkeys* reference is used to store all created foreign keys during step 2 in order to be able to update them at step 3.

```

operation createColumns(table : Table, cls : Class, prefix : String) is
do
  // add all attributes
  getAllAttributes(cls).each { att |
    createColumnsForAttribute(table, att, prefix)
  }
  // add all associations
  getAllAssociation(cls).each { asso |
    createColumnsForAssociation(table, asso, prefix)
  }
end

operation createColumnsForAttribute(table : Table, att : Attribute, prefix : String) is
do
  // The type is primitive : create a simple column
  if PrimitiveDataType.isInstance(att.type) then
    var c : Column init Column.new
    c.name := prefix + att.name
    c.type := att.type.name
    table.cols.add(c)
    if att.is_primary then table.pkey.add(c) end
  else
    var type : Class type := att.type
    // The type is persitant
    if isPersistentClass(type) then
      // Create a FKey
      var fk : FKey init FKey.new
      fk.prefix := prefix + att.name
      table.fkeys.add(fk)
      fk.references:=class2table.getTargetElem(getPersistentClass(type))
      fkeys.add(fk)
    else
      // Recursively add all attrs and asso of the non persistent table
      createColumns(table, type, prefix + att.name)
    end
  end
end

```

Figure 12: Implementation of step 2, columns creation.

Figure 12 presents the implementation of method *createColumns* and *createcolumnsForAttribute*. The *createColumns* operation creates the columns in a table by adding columns for all attributes of the class and all outgoing association from the class. The operations *getAllAttribute(Class)* and *getAllAssociation(Class)* are defined to get all the attributes and outgoing association of a class and all its subclasses.

The operation *createcolumnsForAttribute* handles the creation of columns corresponding to an attribute. Three cases have to be considered:

- If the type of the attribute is simple a single column is created.
- If type of the attribute is persistent, a foreign key is created and the columns in the table will be created at step 3 when all table have been processed.

- If type of the attribute is non-persistent then columns corresponding to attribute in the non-persistent type are added in the table. This is done by a recursive call to method *createColumns*.

The operation *createcolumnsForAssociation* handles the creation of columns corresponding to an association. This operation is not detailed on the figure as it is very similar to *createcolumnsForAttribute* except that the destination type of association cannot be a simple type.

```

class FKey
{
  reference references : Table
  reference cols : Column[1..*]

  /**
   * prefix for the name of the columns
   * used by the createFKeyColumns method
   */
  attribute prefix : String

  /**
   * Create the FKey columns in the table
   */
  operation createFKeyColumns() is do
    var src_table : Table
    src_table ?= container
    // add columns
    references.pkey.each{ k |
      var c : Column init Column.new
      c.name := prefix + k.name
      c.type := k.type
      self.cols.add(c)
      src_table.cols.add(c)
    }
  end
}

```

Figure 13: Implementation of step 3, updating foreign keys.

Figure 13 presents the implementation of step 3. The code has been directly added to the RDBMS metamodel in the class *FKey*. An attribute *prefix* has been added to the class to store the name prefix of the columns to create. When a Kermeta metamodel is generated from an ECore metamodel, any property or operation can be added. The added properties can be considered as “non-persistent” because as they are not in the ECore metamodel they will not be saved when a model is serialized using EMF.

Testing / using the transformation

This section briefly presents how the transformation can be practically used within the Kermeta environment. As Kermeta is fully compatible with the EMF, models can be created, modified and visualized using EMF generic tools. Figure 14 is a screenshot of an input model for the transformation. Figure 15 displays the Kermeta workbench which has been developed as an eclipse plug-in. finally Figure 16 displays the output model obtained by running the transformation.

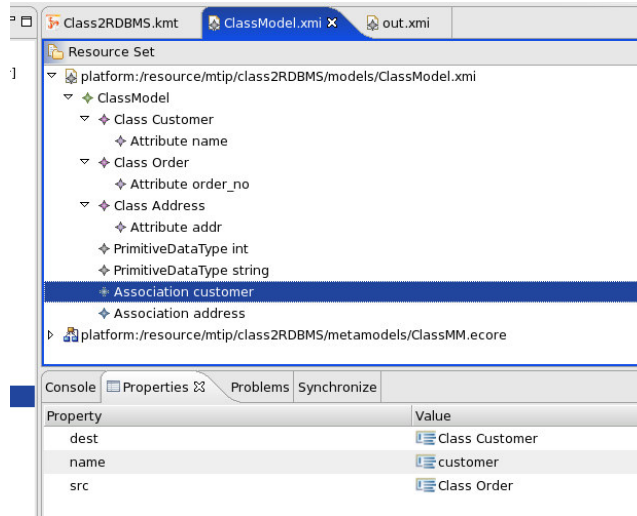

Figure 14: An input model.

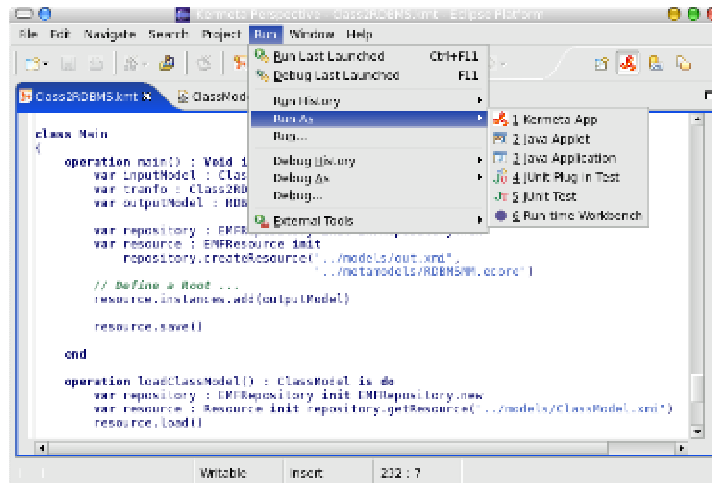

Figure 15: Execution of the transformation.

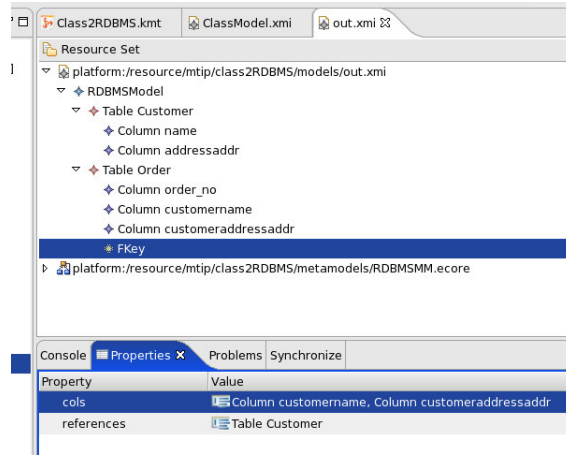

Figure 16: Generated output model.

5.4 Conversion of Roman to/from Arabic numbers in Kermeta

This section presents the implementation of the optional model transformation from Arabic to Roman number and vice-versa. The transformation has been implemented in Kermeta in both directions. The following presents the metamodel that has been used to represent Arabic and Roman numbers, and then details the implementation of the transformation itself.

The metamodels

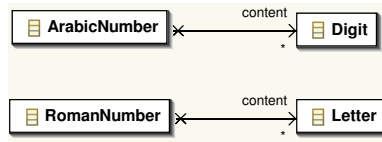

Figure 18: Visual representation of the metamodels

An Arabic number simply consists of a collection of digits and a Roman number in a collection of letters.

```

class ArabicNumber
{
  reference content : Digit[0..*]
  operation toString() : String is do
    result := ""
    content.each{digit |
      result := result + digit.~value.toString()
    }
  end

  operation getValue() : Integer is do
    result := 0
    content.each{n | result := result*10 + n.~value}
  end

  // precondition newValue < 10000
  operation setValue(newValue : Integer) is do
    [...]
  end
}

class Digit
{
  attribute ~value : Integer
}

```

Figure 19: Executable metamodel of arabic numbers in Kermeta.

```

class RomanNumber
{
  reference content : Letter[0..*]
  operation toString() : String is do
    result := String.new()
    content.each{letter | result := result + letter.~value}
  end
  operation getValue() : Integer is do
    [...]
  end
}

class Letter
{
  attribute ~value : String
  operation getValue() : Integer is do
    if value == "I" then result := 1
    else if ~value == "V" then result := 5
    else if ~value == "X" then result := 10
    else if ~value == "L" then result := 50
    else if ~value == "C" then result := 100
    else if ~value == "D" then result := 500
    else if ~value == "M" then result := 1000 end
  end end end end end end
end
}

```

Figure 20: Executable metamodel of roman numbers in Kermeta.

The transformation

Figure 21 presents the implementation of the transformation in Kermeta. The method *roman2arab* is very straightforward as the roman number metamodel contains already a method *getValue* which computes the integer value of a roman number. The method *arab2roman* is designed to transform arabic numbers lower than 3999.

```

class Main {
  // convert a roman number to an arabic one
  operation roman2arab(r : RomanNumber) : ArabicNumber is do
    result := ArabicNumber.new()
    result.setValue(r.getValue())
  end
  // convert an arab number to a roman one
  // precondition : a < 3999
  operation arab2roman(a : ArabicNumber) : RomanNumber is do
    result := RomanNumber.new()
    var position : Integer init a.content.size
    // assertion: position <= 4
    if position == 4 then
      addDigit2roman(result,a.content.elementAt(0), "M"," overflow"," overflow")
      position := position - 1
    end
    if position == 3 then
      addDigit2roman(result,a.content.elementAt(a.content.size-3), "C","D","M")
      position := position - 1
    end
    if position == 2 then
      addDigit2roman(result,a.content.elementAt(a.content.size-2), "X","L","C")
      position := position - 1
    end
    if position == 1 then
      addDigit2roman(result,a.content.elementAt(a.content.size-1), "I","V","X")
    end
  end
  // convert a single digit to roman style, depending on its position
  operation addDigit2roman(r: RomanNumber, d : Digit, unit : String, five : String, ten : String) is do
    if d.-value < 4 then addLetters(r,d.-value, unit)
    else if d.-value == 4 then addLetters(r,1,unit)
      addLetters(r,1,five)
    else if d.-value < 9 then do
      addLetters(r,1,five)
      addLetters(r,d.-value-5, unit)
    end
    else if d.-value == 9 then do addLetters(r,1,unit)
      addLetters(r,1,ten) end
    end end end end
  end
  // add letter 'l' 'times' times
  operation addLetters(r: RomanNumber, times : Integer, l : String) is do
    var aLetter : Letter init Letter.new()
    aLetter.-value := l
    from var i : Integer init 0 until i >= times
    loop
      r.content.add(aLetter)
      i := i + 1
    end
  end
}

```

Figure 21: Implementation of the transformation in Kermeta.

5.5 Refactorings in Kermeta

This section shows how we can use well-known OO design techniques such as design patterns to develop model transformations. In contrast with more generative transformations (such as the class to RDBMS example) which map a whole model to another, model refactorings²¹ are typically used as model edition primitives. A given refactoring can be used multiple times, in different contexts, and each application takes the development process a small step forward. The transformation tool should be as interactive as possible to ease this process by allowing the developer to experiment and progress through trial and error.

We don't put the emphasis on the refactoring presented here itself, which is really simple (moving a given method up to a superclass) but on the application of the *Command* design pattern to specify refactorings.

Refactorings as Commands

Firstly, a refactoring is a generic transformation which has to be parameterized; in our case, we have to specify which method we want to move, and to which superclass we want to move it. Then the tool needs to check the refactoring preconditions; if they are respected it will proceed to transform the model. The interface for refactorings thus defines three methods as follows:

```
abstract class RefactoringCommand
{
    operation check() : Boolean is abstract
    operation transform() : Void is abstract
    operation revert() : Void is abstract
}
```

This interface specifies three operations playing the Execute() role in the GoF pattern description:

- check() is called to evaluate preconditions on the model before transformation; when these preconditions are satisfied the transformation is guaranteed to be a refactoring so it can be applied safely.
- transform() applies the transformation.
- revert() should return the refactored model to its previous state.

Concrete refactorings must subclass `RefactoringCommand` and provide methods for its three operations:

```

class MoveUpMethod inherits RefactoringCommand
{
  reference methodToMove : ClassHierarchyMM::Method
  reference destinationClass : ClassHierarchyMM::Class
  reference originClass : ClassHierarchyMM::Class

  method check() : Boolean is do

    // assert destinationClass is a superclass of methodToMove's owner
    if not destinationClass.isSuperclass
      (methodToMove.owner.asClass) then
      raise Exception.new
    end

    // assert new methodToMove won't conflict
    if not conflicts(methodToMove, destinationClass).empty then
      raise Exception.new
    end
  end

  /** Apply the transformation : Move method to destination class */
  method transform() : Void boolean
  // could return a "successfully applied"
  is do
    // memorize current owner for revert()
    originClass := methodToMove.owner.asClass
    // move method to destination
    methodToMove.owner := destinationClass
  end

  /** undo the transformation : Move method back to original owner */
  method revert() : Void
  is do
    methodToMove.owner := originClass
  end

  /** list conflicts that would appear if the transformation is
  * applied */
  operation conflicts(m : ClassHierarchyMM::Method,
    someClass : ClassHierarchyMM::Class) :
    Collection<ClassHierarchyMM::Method>
  is do
    result := Set<ClassHierarchyMM::Method>.new
    result := someClass.subclasses.collect{ c |
      c.features }.select{ f | (f.name == m.name) and (f != m) }
  end
}

```

The metamodel

For this example we will use the small subset of the UML metamodel shown below, which defines classes, inheritance hierarchy and methods. This Kermeta metamodel also defines utility methods in metaclasses:

```

package ClassHierarchyMM;

require kermeta

using kermeta::standard

```

```

abstract class Classifier inherits GeneralizableElement
{
  attribute feature : seq Feature[0..*]#owner
  operation asClass() : Class is do
    result ?= self
  end
}

class Class inherits Classifier
{
  operation superclasses() : Collection<Class> is do
    result := generalization.collect{ g |
      var p : Class
      p ?= g.parent
    }
  end

  operation isSuperclass(child : Class) : Boolean is do
    result := child.superclasses().contains(self)
  end

  operation subclasses() : Collection<Class> is do
    result := specialization.collect{ g |
      var p : Class
      p ?= g.child
    }
  end

  operation isSubclass(child : Class) : Boolean is do
    result := child.subclasses().contains(self)
  end
}

class Feature inherits ModelElement
{
  reference owner : Classifier[1..1]#feature
  attribute visibility : String
}

abstract class GeneralizableElement inherits ModelElement
{
  reference specialization : Generalization[0..*]#parent
  reference generalization : Generalization[0..*]#child
}

class Generalization inherits ModelElement
{
  reference parent : GeneralizableElement[1..1]#specialization
  reference child : GeneralizableElement[1..1]#generalization
}

class Method inherits Feature
{
  attribute body : String
}

class Model inherits ModelElement
{
  attribute ownedElement : ModelElement[0..*]#namespace
}

abstract class ModelElement
{
  reference namespace : Model#ownedElement
  attribute name : String
}

```

Using the Transformation

```

@mainClass "Refactoring::Main"
@mainOperation "main"

package Refactoring;

require kermeta
require "../models/ClassHierarchyMM.kmt"
using kermeta::standard
using kermeta::utils
using kermeta::persistence
using kermeta::exceptions

// definition of RefactoringCommand
// definition of MoveUpMethod

class Main
{
  reference resource : Resource
  reference inputModel : ClassHierarchyMM::Model

  operation main() : Void
  is do
    loadResource("../models/SampleModel.xml")
    inputModel ?= findElement(ClassHierarchyMM::Model, "root")

    var transfo : MoveUpMethod init MoveUpMethod.new
    transfo.methodToMove ?= findElement(ClassHierarchyMM::Method, "m")
    transfo.destinationClass ?= findElement(ClassHierarchyMM::Class,
                                           "AncestorClass")

    if transfo.check() then
      transfo.transform()
      stdio.println("transformation applied")
    else
      stdio.println("precondition not satisfied")
    end
    resource.saveWithNewURI("../models/SampleModel-out.xml")
  end

  operation loadResource(filename : String)
  is do
    var repository : EMFRepository init EMFRepository.new
    resource := repository.getResource(filename)
    resource.load()
  end

  operation findElement(metaClass : kermeta::reflection::Class,
                       name : String) :
    ClassHierarchyMM::ModelElement
  is do
    var found : Boolean init false
    from var it : Iterator<Object> init resource.instances.iterator
    until found or it.isOff
    loop
      var next : Object init it.next
      if (metaClass.isInstance(next)) then
        var n : ClassHierarchyMM::ModelElement
        n ?= next
        if n.name == name then
          result ?= next
          found := true
        end
      end
    end
  end
end
}

```

5.6 Determinization and minimization of automata in Kermeta

These transformations show the power of OCL-like constructs to manipulate collections.

Formal definition of non-determinist finite automaton metamodel

Formally, a non-determinist finite automaton is a $A = (\Sigma, Q, T, q_0, F)$, where :

- Σ is an alphabet
- Q is a finite set of states
- T is a set of transitions rules, such as $si \ X \ a \ --> \ sj$ where $si, sj \in Q^2$ and $a \in \Sigma \setminus \{e\}$
- q_0 is the initial state
- F is the set of final states

Automaton metamodel

We considered as simple case of finite automaton: an automaton that as an initial state, (*initialState*), a set of available states (*stateSet*), a set of transitions (*transitionSet*), an alphabet, an a set of final states (*finalStateSet*). We chose that our automaton are all e-free (no e-transitions).

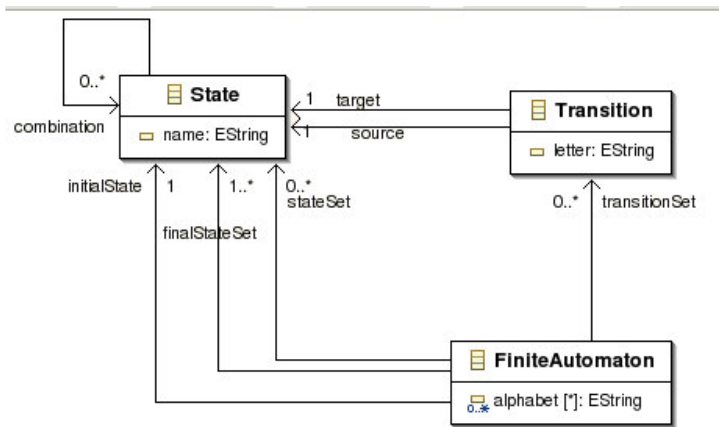

Figure 22: Automaton metamodel.

combination is an attribute of State that is used for two purposes :

- For the determinisation implementation : it represents each new group of state that is created for the determinist automaton
- For the minimisation implementation : it is used as a marker for states of the input automaton that have already been added in the equivalence classes of the output-minimal automaton. This is a light optimisation of the computation of the equivalence classes that constitute the new states of the minimalized automaton.

alphabet is, in Kermeta implementation, a derived property that is computed from the automaton instance (we get all the letters defined on the transitions)

Kermeta representation

The following figure shows the Kermeta textual representation of the automaton metamodel.

```
class FiniteAutomaton
{
  reference stateSet : set State[0..*]//Set<State> // #owningFA
  reference initialState : State
  reference finalStateSet : set State[0..*]
  reference transitionSet : set Transition[0..*]
  property readonly alphabet : Set<String>
  getter is do
    result := self.seqToSet(self.transitionSet.collect{e|e.letter})
  end

  /** Initialize a new automaton from an existing one */
  operation initialize(initState : State) is do
    stateSet.add(initState)
    initialState := initState
    initialState.combination := Set<State>.new
  end
}

class State
{
  reference combination : Set<State>
  reference name : String
}

class Transition
{
  reference source : State
  reference target : State
  reference letter : String
}
```

Formal definitions of the determinization algorithm

Determinist automaton

A finite automaton is determinist if and only if the relation t is a transition function such as:

$t : Q \times \Sigma \rightarrow Q$ (e-transition no more allowed, but in our case we don't work with it)

from a state, there is at most one possible transition with the same letter

Algorithm

The algorithm for determinizing a non-determinist finite automaton is a classical problem for the automata such as defined in our metamodel. An introduction of it can be found in²². Here it is:

Initialisation of $A' = (\Sigma, Q', T', q_0', F')$, determinist version of an automaton A :

- T' initialized to \emptyset
- q_0' initialized to $\{ q_0 \}$
- Q' initialized to $\{ q_0' \}$

q' is a “new” state that is a part of Q ($q' \in P(Q)$)

for each state q' of Q' not considered yet do

for each letter a of Σ do

$q'' \leftarrow \{ y \mid x \hat{=} q' \text{ and } y \hat{=} Q / (x, a, y) \hat{=} T \}$

$T' \leftarrow T' \dot{\cup} \{ (q', a, q'') \}$

$Q' \leftarrow Q' \dot{\cup} \{ q'' \}$

rof

rof

$F' \leftarrow \{ q' \in Q' \mid q' \in F \}$

Implementation

```

class Determinization
{
  reference processed_states : Set<State>

  operation main() : Void is do

    // Input automaton (non-determinist)
    var input : FiniteAutomaton init Sampler.new.createSample1()
    var output : FiniteAutomaton init FiniteAutomaton.new
    // Control variables
    processed_states := Set<State>.new
    // Initialize output automaton with input.initialState
    output.initialize(input.initialState)
    // Apply the determinisation
    determinize(input, output, output.initialState)

    // Define the final states : q' intersection initial
    // Final states is void
    output.finalStateSet.addAll
    (
      output.seqToSet( output.stateSet.select {
        e | e.combination.detect{ a |
          input.finalStateSet.contains(a) } != void } )
    )
  end

// THE DETERMINISATION ALGORITHM
//input : initial automaton
// output : final determinized automaton
// output_state : the next state to consider
operation determinize( input : FiniteAutomaton,
                      output : FiniteAutomaton,
                      output_state : State)
is do
  // for each state not considered yet
  if not processed_states.contains(output_state) then
    processed_states.add(output_state)
    var newq : State init State.new
    // For each letter of the alphabet
    from var lit : Iterator<String> init input.alphabet.iterator
    until lit.isOff
    loop
      // There exists a state x of q'
      // (where q' is a P(Q)) and a state y from Q
      // such that: x --l--> y belongs to input.transitionSet
      var nextl : String init lit.next
      newq.combination := Set<State>.new
      newq.combination.addAll(
        input.seqToSet(
          input.transitionSet.
            select { e | e.letter.equals(nextl) }.
            select { a | output_state.equals(a.source)
              or output_state.combination.contains(a.source)}.
            collect { b | b.target } )
      )
      newq.name := join(newq.combination.collect{ a | a.name })
      // Add the state to the output automaton if we found one
      if (newq.combination.size > 0) then
        // Add the new transition
        var newt : Transition init Transition.new
        newt.initialize(output_state, newq, nextl)
        output.transitionSet.add(newt)
      end if
    end loop
  end if

```

```

        // Add the new state if it is not already added
        if (output.stateSet.
            detect { e | newq.name == e.name } == void)
        then
            output.stateSet.add(newq)
        end
        self.determinize(input, output, newq)
    end
end // End of loop
end // End of processing of not considered state

end

// Create a special name for new states with their combination :
// the state -> { q0, q1 } is name "q0q1"
operation join( str_seq : Collection<String> ) : String is do
    result := ""
    from var it : Iterator<String> init str_seq.iterator
    until it.isOff
    loop
        result.append(it.next)
    end
end
end
}

```

Formal definition of the minimization algorithm

A minimal automaton is an optimized (pre-determinized) automaton that has the minimum number of states that performs the same function (i.e. produces the same language in a language automaton) of its equivalent automaton. The reader can find a formal definition of minimal automaton in²³.

We chose to implement a simple algorithm provided by²³. It is called a **layerwise** computation of the equivalence relations. A better implementation should be provided, but would need a few optimizations for the list handling in Kermeta. However, the language was quite ergonomic, thanks to the implementation of OCL constraints, and made the implementation easier to write.

The algorithm

The algorithm finds, incrementally, the pair of states (p, q) such as p and q ra

AFD $M = (Q, A, q_0, F, d)$

$H : (Q - F)^2 \cup Q^2$

Hold : Q^*Q

Begin

do

 Hold := H

 for each (p, q) in Q^*Q do

 for each letter a in A do

 s = d(p,a)

 t = d(q,a)

 if (s,t) is not in H then remove (p,q) from H

 until Hold == H

end

Implementation

The implementation of the minimization was a bit more complicated, since we had to construct also, from the pairs of states given by the algorithm execution, the new states (which are the equivalence classes of the pairs of equivalent states $(p,q$ in the algorithm), and the new transitions. We show here only the relevant parts of the implementation of minimization algorithm in Kermeta.

```

class Minimization
{
  reference equivalent_pairs : set Pair[0..*]
  reference all_input_pairs : Set<Pair>
  reference helper : AutomatonHelper

  operation main() : Void is do

    helper := AutomatonHelper.new
    // Input automaton (non-determinist)
    var input : FiniteAutomaton init Sampler.new.createSampleM1()
    var output : FiniteAutomaton init FiniteAutomaton.new
    all_input_pairs := Set<Pair>.new

    // Initialize the complete set of
    // possible pairs: all_input_pairs = Q x Q (Q is the stateSet)
    // Initialize Eo : equivalent_pairs
    // = { F \ Q }Ã² ^ FÃ² (states that accept
    // the {e} transition or empty word
    input.stateSet.each { p | input.stateSet.each { b |
    // Check : (p,q) is in Eo, i.e either both are final
    // states or both are NOT final states
    var isFinalLeft : Boolean init input.finalStateSet.
        detect { e | p.name == e.name }!=void
    var isFinalB    : Boolean init input.finalStateSet.
        detect { e | b.name == e.name }!=void
    // Also fill the all input pairs
    if find_one(all_input_pairs, p, b) == void
    then all_input_pairs.add(createPair(p, b)) end
    if ((isFinalLeft and isFinalB)
        or (not isFinalLeft and not isFinalB))
        and
        find_one(equivalent_pairs, p, b) == void
    then
        equivalent_pairs.add(createPair(p, b))
    end
    } }

    // Minimalize
    minimalize(input, output)
    output.prettyprint()
  end

  operation minimalize(input : FiniteAutomaton,
    output : FiniteAutomaton) : Set<Pair> is do
    result := equivalent_pairs
    var old_equivalent_pairs : Set<Pair> init all_input_pairs
    from var it : Iterator<Pair> init old_equivalent_pairs.iterator
    until old_equivalent_pairs == result
    loop
      old_equivalent_pairs := result
      // For each pair
      old_equivalent_pairs.each { eqPair |
      // For each letter of

```

```

    if (isNotOwnedTransition(input,
                             eqPair,
                             old_equivalent_pairs) == true)
    then
        // remove this pair from eq. pairs (H)
        result := old_equivalent_pairs
        var fp : Pair
            init find_one(result, eqPair.left, eqPair.right)
        if (fp!=void) then
            result.remove(fp)
        end
    end
}

end
// Set the result
result := Set<Pair>.new
result.addAll(old_equivalent_pairs)
// Create the equivalent classes, which become the new states
var classSet : Set<Set<State>> init Set<Set<State>>.new
createEquivalenceClasses(output,
                          input.stateSet,
                          old_equivalent_pairs)

output.stateSet.each
{ s | s.name := helper.join(s.combination.collect{ a | a.name }) }

// Create the transition between the new states
// inputStates contains the links to their eq.class
createEquivalentTransitions(output.stateSet,
                              input.stateSet,
                              input.transitionSet)

end

// Equivalence relation  $xRy == yRx$  :
operation find_one(pairSet : Set<Pair>,
                    left : State,
                    right : State) : Pair is do
    result := pairSet.detect { p |
        (p.left.name == left.name and p.right.name == right.name) or
        (p.right.name == left.name and p.left.name == right.name) }
end

// Returns true if for each letter of the input automaton,
// a pair (p,q) does not satisfy the "T(p, a), T(q, a)
// belongs_to the equivalent_pairs" condition
operation isNotOwnedTransition(automaton : FiniteAutomaton,
                               pair : Pair,
                               equivalent_pairs : Set<Pair>) :
    Boolean

is do
    // if there exists a letter a in the automaton such as
    // T(pair.left, a), T(pair.right, a) belongs to distinct_pairs
    // "void" pair is allowed!
    result := false
    from var it : Iterator<String> init automaton.alphabet.iterator
    until it.isOff or result == true
    loop
        var letter : String init it.next
        var tleft : Transition init automaton.
            transitionSet.detect { t | t.source.name==pair.left.name
                and t.letter == letter }
        var tright : Transition init automaton.
            transitionSet.detect { t | t.source.name==pair.right.name
                and t.letter == letter }
        if (tleft!=void and tright!=void) then

```

```

// empty word belongs to accepted words
if find_one(equivalent_pairs,
            tleft.target,
            tright.target) == void then
    result := true
end
end
end
end
end

// Create the equivalenceClasses that will constitutes
// the states of the minimal output automaton.
operation createEquivalenceClasses(output : FiniteAutomaton,
                                   stateSet : Set<State>,
                                   equivalent_pairs : Set<Pair>) :
                                   Set<Set<State>> is do
var eqClass : Set<State> init Set<State>.new
result := Set<Set<State>>.new
from var it : Iterator<State> init stateSet.iterator
until it.isOff
loop
var state : State init it.next
var news : State
equivalent_pairs.select
{ pair | pair.left == state }.each
{ pair |
// combination becomes a "marker" for classed states
// if it is void, it means that it does not
// belong to a eqclass yet
if (state.combination == void) then
// create the eq. class and the state
eqClass := Set<State>.new
eqClass.add(pair.left)
news := helper.createState(state.name)
news.combination.add(eqClass.one)
helper.join(eqClass.collect{ a | a.name })
output.stateSet.add(news)
result.add(eqClass)
// Mark state that is already added
// we use combination to ease the transition computation
state.combination := Set<State>.new
state.combination.add(news)
end
// Process the right element of the pair :
// add it to the eq.class of the left element!
var sright : State init stateSet.
detect { s | pair.right == s and s.combination == void }
if (sright != void) then
sright.combination := Set<State>.new
result.detect{ c | c.contains(state)}.
add(State.clone(pair.right))
output.stateSet.
collect { s | s.combination}.
detect{ c | c.contains(state) }.
add(State.clone(pair.right))
end
end
// Set the eq-class of current state in its "combination"
// attribute if it was skipped because already processed
// through the left element selection
if (state.combination.size ==0) then
state.combination.add(output.stateSet.
detect{ s | s.combination.contains(state)})
end
end
end
end
end
}

```

```

// eqClassStateSet : the minimal automaton set of states
// stateSet : the input automaton set of states
// transitionSet : the input automaton set of transitions
operation createEquivalentTransitions
    ( eqClassStateSet : Set<State>,
      stateSet : Set<State>,
      transitionSet : Set<Transition> ) :
      Set<Transition> is do

result := Set<Transition>.new
// for each eq-class
from var it : Iterator<State> init stateSet.iterator
until it.isOff
loop
    var nextInputState : State init it.next
    // Get the eq.class to which the current state belongs
    var nextEqClassState : State init
        nextInputState.combination.one
    // For each letter, Get the transition for which
    // the current state is a source
    var nextTransitionSet : Sequence<Transition> init
        transitionSet.select { t | t.source == nextInputState }
    // The target combination is the eq. class target of
    // the new transition!
    nextTransitionSet.each { t |
    // Add this transition
    if result.
        detect { rt | rt.source == nextEqClassState and
            rt.letter == t.letter } == void
    then
        var newt : Transition init Transition.new
        var nextEqClassStateTarget : State init
            eqClassStateSet.
                detect { s | s.combination.contains(t.target) }
        newt.initialize(nextEqClassState,
            nextEqClassStateTarget,
            t.letter)
        result.add(newt)
    end
    }
end
// Print the transition
stdio.writeln("transitions : " + result.size.toString)
result.each { t | stdio.writeln(t.toString) }
end
}

```

6 Conclusion

In this paper we have shown how executable meta-languages could be used to express model transformations.

We have explained the rationales for building object-oriented executable meta-languages, and then discussed the perceived benefits of these languages applied to the model transformation field.

We are currently in favor of a level of language support for model transformation which is between totally general purpose languages (such as Java) and model transformation domain specific languages such as specified by QVT. Our approach could be described as model domain specific languages.

Nevertheless, Kermeta is first and foremost an executable meta-language, which can be used to for a wide range of purposes, including model transformation but also to specify the abstract syntax of languages under the shape of metamodels. As Kermeta is executable, the operational semantic of these languages can then be further specified, and even implemented by reusing domain specific libraries. Hence, Kermeta is a language development environment, where domain specific experimentations can be conducted via libraries, and then injected into Kermeta metamodels, which in turn model domain specific languages (for instance for model transformation).

Interestingly, we have found that it was more difficult to understand the description of the required transformations than to write the transformations. This leads us to believe that it would be useful to find more precise ways to specify the transformations.

The work presented in this paper may be viewed as an experimentation in applying executable meta-languages to model transformations. Our work is obviously far from bringing definitive answers to the complex problems addressed by the MTIP workshop. However the presented material may contribute, with many other ongoing research works on similar topics, to a better understanding of language requirements with respect to model transformations and software engineering.

References

- ¹ OMG. MOF 2.0 Core Final Adopted Specification, Object Management Group, <http://www.omg.org/cgi-bin/doc?ptc/03-10-04>, 2004.
- ² Netbeans MDR, web site <http://mdr.netbeans.org/>
- ³ Budinsky, F., Steinberg, D., Merks, E., Ellersick, R. and Grose, T. *Eclipse Modeling Framework*. Addison Wesley Professional, 2003.
- ⁴ A. Ledeczi, M. Maroti, A. Bakay, G. Karsai, “*The Generic Modeling Environment*”, Proceedings of the IEEE International Workshop on Intelligent Signal Processing, WISP’2001, Budapest, Hungary, may 24-25, 2001
- ⁵ Vojtisek, D. and Jézéquel, J.-M. MTL and Umlaut NG: Engine and Framework for Model Transformation. *ERCIM News*, 58.
- ⁶ Bézivin, J, Dupé, G, Jouault, F, Pitette, G, and Rougui, EJ : First experiments with the ATL model transformation language: Transforming XSLT into XQuery. In: OOPSLA 2003 Workshop, Anaheim, California.
- ⁷ OMG. Revised submission for MOF 2.0 Query/View/Transformation, Object Management Group (QVT-Merge Group), <http://www.omg.org/cgi-bin/apps/doc?ad/2005-03-02>, 2005.
- ⁸ OMG. UML 2.0 Object Constraint Language (OCL) Final Adopted specification, Object Management Group, <http://www.omg.org/cgi-bin/doc?ptc/2003-10-14>, 2003.
- ⁹ Mellor, S., Tockey, S., Arthaud, R. and Leblanc, P. Action Language for UML: Proposal for a Precise Execution Semantics. *Proceedings of UML 98 (LNCS1618)*. 307-318.
- ¹⁰ Borras, P., Clement, D., Despeyroux, T., Incerpi, J., Kahn, G., Lang, B. and Pascual, V. Centaur: the system. *Proceedings of the ACM SIGSOFT/SIGPLAN software engineering symposium on practical software development environments*, 13 (5). 14 - 24.
- ¹¹ Clark, T., Evans, A., Sammut, P. and Willans, J. Applied Metamodelling: A Foundation for Language Driven Development, <http://albini.xactium.com>, 2004.
- ¹² Greenfield, J., Short, K., Cook, S., Kent, S. and Crupi, J. *Software Factories: Assembling Applications with Patterns, Models, Frameworks, and Tools*. Wiley, 2004.
- ¹³ Muller, P.-A., Studer, P., Fondement, F. and Bezivin, J. Platform independent Web Application Modeling and Development with Netsilon. *Accepted for publication in Journal on Software and Systems Modelling (SoSym)*. http://www.sciences.univ-nantes.fr/ina/atl/www/papers/netsilon_sosym.pdf.
- ¹⁴ X. Blanc, S. Bouzitouna and M.P. Gervais, A Critical Analysis of MDA Standards through an Implementation: the ModFact Tool, First European Workshop on Model Driven Architecture with Emphasis on Industrial Application, March 17-18, 2004, Enshede, The Netherlands.
- ¹⁵ Muller, P.-A., Fleurey, F., Jézéquel, J.-M.: Weaving executability into object-oriented meta-languages. In L. Briand, S.K., ed.: *Proceedings of MODELS/UML’2005*. Volume to be published of LNCS., Montego Bay, Jamaica, Springer (2005)
- ¹⁶ <http://www.kermeta.org>
- ¹⁷ D. Roberts and R. Johnson. Evolve frameworks into domain-specific languages. In *3rd International Conference on Pattern Languages*, Allerton Park, Ill., September 1996.
- ¹⁸ <http://modelware.inria.fr/mtl>
- ¹⁹ Gamma Erich, Helm Richard, Johnson Ralph, and Vlissides John. *Design Patterns: Elements of Reusable Object-Oriented Software*. Addison-Wesley, 1994.
- ²⁰ <http://www.omondo.com/>
- ²¹ Gerson Sunye, Damien Pollet, Ives Le Traon, and Jean-Marc Jezequel. Refactoring UML models. In *Proceedings of UML 2001*, pp. 134-148
- ²² Julia, Automates finis, University Course, Université de Nice Sophia-Antipolis, France
- ²³ Watson, B.W, A Taxonomy of finite automata minimization algorithms, Technical Report, Faculty of Mathematic and Computing Science, Eindhoven University of Technology, the Netherlands (Sep. 1994)