

Development of a miniature articulated arm and pair of eyes for the humanoid robot Robota

F.Guenter, A.Guignard, L.Piccardi, M.Calzascia, A.Billard
STI-I2S-ASL3

Swiss Federal Institute of Technology Lausanne (EPFL)
CH-1015 Lausanne, Switzerland
florent.guenter@epfl.ch
<http://robota.epfl.ch>

January 6, 2005

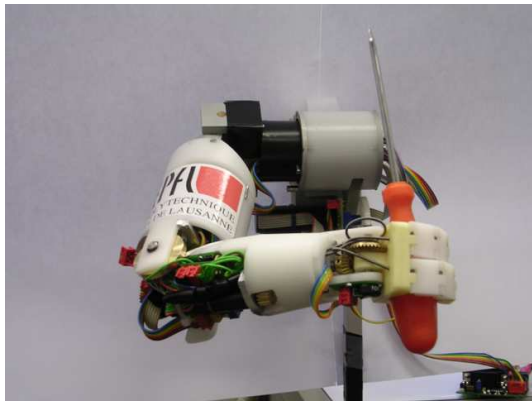

Figure 1: Robota's prototype of a 7 DOF arm

Abstract

Humanoids remain luxurious robots, not easily purchasable or reproducible. The Robota project aims at building a low cost open humanoid platform, for use as educational tool for normal and disabled children. This paper reports on the mechanical design of a miniature 7 degrees of freedom articulated arm and of a miniature 3 degrees of freedom pair of eyes for Robota. We describe in details the mechanical construction, the electronic circuits and the control system, so that these could be easily duplicated by other laboratories.

1 Introduction

Humanoid robots are in constant and very rapid development. Unfortunately, as in many areas of robotics, exception being made of industrial arm manipulators and mobile (vehicle-like) robots, humanoid robots are not easily purchasable or reproducible. Indeed, humanoids remain luxurious robots, their costs reaching the billion of dollars. and academic laboratories, building those, do not publish a sufficiently detailed description of the mechanics and electronics of their robots.

In order for research on the control of humanoid robots to progress faster, we need to be able to cross-validate results by having several laboratories working on similar platforms. Miniature humanoid robots can provide such a standard, by providing low cost platforms.

Recent progresses in miniature humanoid robotics has led to the development of three high-quality platforms. These are Honda Asimo [1], Sony QRIO [2] and Fujitsu HOAP robots. Because these platforms are manufactured by companies that aim at exploiting these for profit, the details of the mechanics and electronics remain either undisclosed or protected by world patents. We, thus, depend on these manufacturers for getting access to these robots. Azimo and Qrio are, to this date, not for sale. Azimo can be rented for around \$100k per year. HOAP-1 and HOAP-2 are the best alterna-

tive. They are for sale at a cost of around \$40k and \$60k respectively.

We badly need to have access to OPEN and low-cost humanoid platforms, that could be easily duplicated by other laboratories. The Robota project aims at creating such an open platform. The present paper describes the details of the mechanical and electronic construction of a miniature 7 degrees of freedom arm and a 3 degrees of freedom pair of eyes for the humanoid robot Robota. Although the mechanical construction is far from being perfect and improvements are in progress, we believe that there is a value to convey the information gathered so far, if only to prevent other laboratories to go through the same design stages.

1.1 The Robota Project

The Robota project constructs a series of multiple degrees of freedom doll-shaped humanoid robots, whose physical features resemble those of a baby. The Robota project is part of a current trend of robotics research that develops educational and interactive toys for children with disabilities; see, e.g. [3]. The Robota project started in 1997 with the first prototype. Numerous iterations thereafter followed, leading to the creation of a commercial prototype, sold by DIDEL SA.

Robota Basic Hardware: The original Robota robot, sold by DIDEL SA, has 5 degrees of freedom (DOF): 1 DOF for each leg, arm and head. DC motors with a 1:6 gearings drive the 5 DOFs, providing a maximum continuous torque of about 90 mNm. Robota's electronic components consist of a Motor Board and a Sensor Board. The Motor board is addressed via a RS232 serial interface from a PC or a PocketPC. The Sensor Board is addressed from the Motor Board via a SPI (serial peripheral interface) serial interface. Motor Board and Sensor Board are controlled by two PIC16FA microcontrollers. Schematic of the electronic boards and of the mechanics are available in the Robota User-Guide at <http://robota.epfl.ch>

Robota's behaviors allow multi-modal human-robot interactions, including the ability to imitate gesture, see Figure 2, to dialog via speech processing/synthesis, and to learn simple composition of motions and of words, see [4, 5].

Applications: The Robota robots find an application in two areas: 1) in education, as a program-



Figure 2: A PocketPC mounted with a FlyCam Camera tracks the motion of the user and sends commands to the microcontrollers and servos of Robota, so that it can imitate the motion of the head and arms of a user.

ming tool at the University, and as an entertaining interactive toy in museums [6]; and 2) in behavioral studies with autistic children, that investigate the potential of an imitator robot to test the ability of autistic children to imitate and to teach these children some simple coordination behaviors [7].

2 Mechanical Design

The design of Robota's body must satisfy several criteria, all driven by the use of Robota in experiments with autistic children, see [7]:

1. The robot's size and weight must be sufficiently small, so that it could be carried by a 4 year-old child. We take, as reference, the average size and weight of commercial dolls, namely 50cm, 1kg.
2. The robot's body and facial features must be cute and resemble that of a human baby, so that the robot's effect on the children can be compared to that of a human.
3. The processing must be done on-board for the robot to be easily set-up in the experimental room.
4. The cost of the robot must be sufficiently low for the collaborating schools and museums to be able to purchase it.

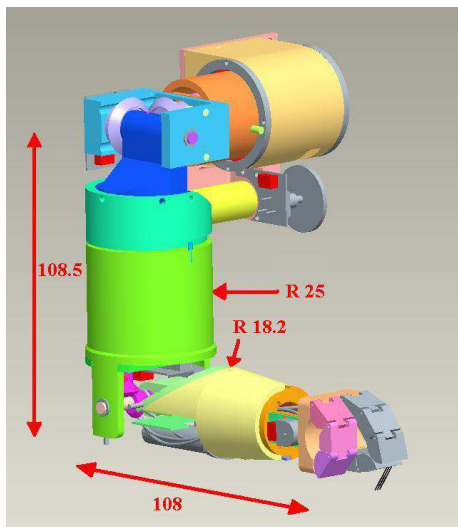

Figure 3: The dimensions of the arm

2.1 The Arm

In order to ensure the overall aesthetic of the construction, the arm segments must have the same proportion as that of a doll or of a baby arm. All the actuators and the electronics must be inside the arm; nothing must protrude. Because of cost and space constraints, we had to rule out solutions closer to the human control system (e.g. hydraulic motors, linear actuators) and use electric rotative motors with a serial placement of the joints. In order to obtain human like movements, the different DOFs were placed in the following order¹: shoulder flexion-extension, shoulder abduction-adduction, shoulder humeral rotation, elbow flexion-extension, wrist rotation, wrist flexion-extension and gripper. All DOFs are bounded to have the same freedom of movement as the equivalent human ones. Table 13 gives a summary of the cost of all components²

The current prototype is a 6 DOFs arm with a 1 DOF gripper. It is 26 centimeter long and 700gr.

¹We are aware of the fact that the human arm is not controlled by a serial muscular system. Nevertheless, the order in which the rotation axes have been placed gives the closest equivalent to the human arm motion.

²Note that this estimate does not include the cost of development of the prototype, nor the cost of manufacturing some special pieces. The whole corresponds approximatively to the salary of three engineers working full-time during 6 months.

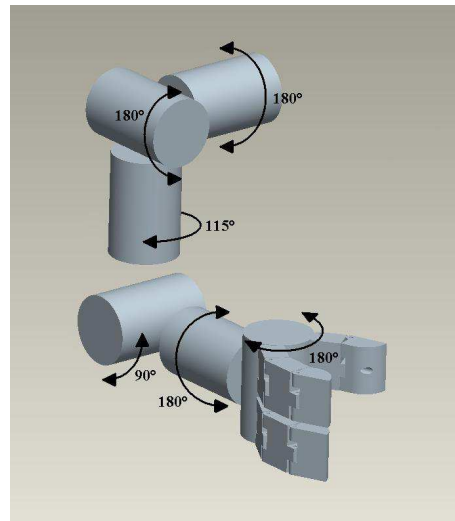

Figure 4: Kinematic chain of the arm (the seventh DOF is grasping)

The motors were dimensioned so as to carry an external load of up to 200 gr. The different DOFs were designed to be reversible, in order to provide an interface for teaching the robot by demonstration [8].

The first three degrees of freedom are placed in the shoulder. The three rotation axes cross at the same point (see Figure 4). This implies that the elbow moves on a sphere. We have one DOF in the elbow and two DOFs in the wrist. The gripper is composed of 3 fingers actuated by one single DOF. To have an absolute measure of the position of each joint, we have placed potentiometers on each axis. We can, thus, measure the absolute position of the arm when the arm is switched on, and, hence, initialize the motor encoders without having to send the motors to the reset position. This ensures minimal risks when the robot interacts with children, by preventing any involuntary motion if the robot should reset itself.

2.1.1 The first degree of freedom

is the shoulder flexion-extension and is bounded to 180°. A cylinder, on which the whole arm is mounted, is guided by two ball bearings (see Figure 5) and driven by a Faulhaber motor of 10mm. The torque transmission is done by a notched belt, hence, avoiding any backlash (except the backlash

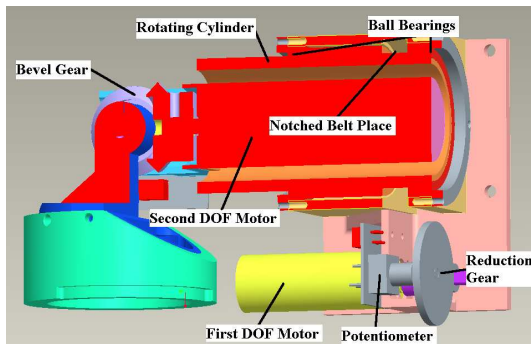

Figure 5: First and second DOF of the arm

on the motor gear). Because we have a demultiplication of 4 with the notched belt, the potentiometer cannot be mounted directly on the motor axes. Because we have two motor rotations for one complete rotation of the cylinder, we use a gear to measure the movement with the potentiometer.

2.1.2 The second degree of freedom

is located inside the cylinder of the first DOF, see Figure 5, and is bounded to 180° . The motor is a Faulhaber 15mm motor. It is the most powerful motor in the arm, as it must produce the largest torque (0.8Nm), assuming an external load of up to 200gr. Although it must produce the same torque as the motor of the 1st DOF, this motor is more powerful because we do not have the space for an additional demultiplication with the bevel gear. In Section 3, we will see that this creates problems when it comes to building the control system. The bevel gear creates a backlash because of its large teeth. Large teeth are required to support the important torque. The potentiometer is placed on the motor axis.

2.1.3 The third degree of freedom

has a range of motion bounded to 115° . The motor, a 10mm of Faulhaber, is placed in the upper arm and produces a direct drive. It supplies a torque of 0.3Nm . The potentiometer is placed on the motor axis, the latter being hold by two screws, (see Figure 6). The fixation point is not centered. This creates a hyper guidance problem. As a consequence, the third degree of freedom is in the limit of reversibility.

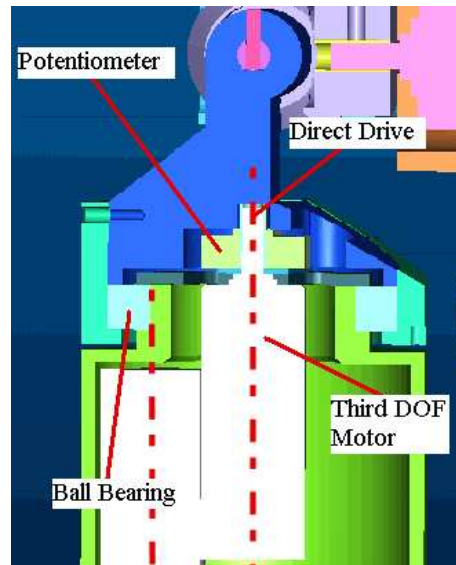

Figure 6: Third DOF of the arm

2.1.4 The fourth degree of freedom

is driven by a 10mm Faulhaber motor, which is also located in the upper arm (see Figure 7). The motor supplies a torque of 0.3Nm . It drives the rotation of the elbow joint through a bevel gear with no demultiplication. The range of movement is bounded to 180° . The potentiometer is placed directly on the elbow axis. The bevel gear creates again a backlash, as mentioned in Section 2.1.2.

2.1.5 The fifth degree of freedom

corresponds to the wrist rotation. The motor (a Maxon of 10mm) is located in the front arm and drives a cylinder containing the motor of the sixth DOF (see Figure 8). Here we have a gear with a ratio of 2.25 and the movement is bounded to 180° , (see section 2.1.1). The solution is then the same, we have used a gear to reduce the rotation and thus be able to measure the position.

2.1.6 The sixth degree of freedom

is the wrist flexion-extension. The motor is a Maxon of diameter 10mm and is placed inside the cylinder of the lower arm (see Figure 9). The transmission is done by a bevel gear with a reduction ratio of 2. The range of motion is bounded to 180°

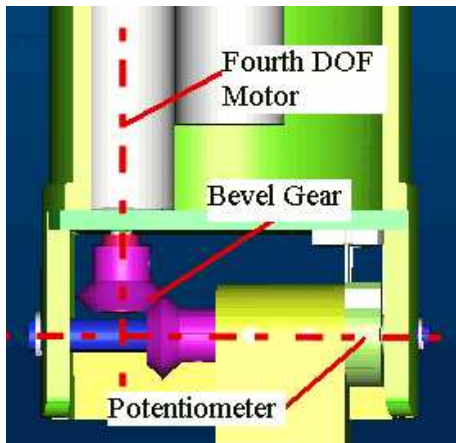

Figure 7: Fourth DOF of the arm

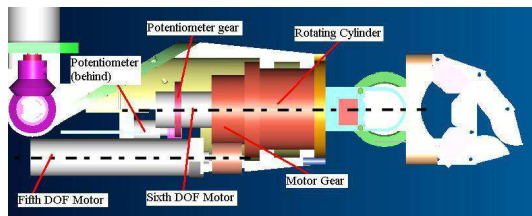

Figure 8: Fifth DOF of the arm

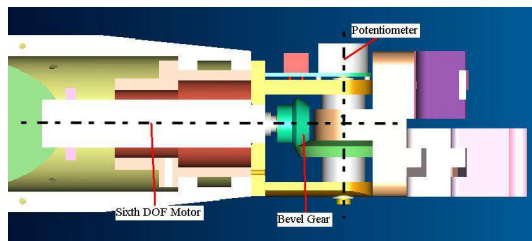

Figure 9: Sixth DOF of the arm

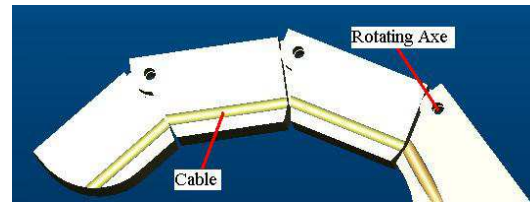

Figure 10: Composition of a finger

<i>DOF</i>	<i>JointLimit</i>	<i>Torque</i>
1	180°	0.8Nm
2	180°	0.8Nm
3	115°	0.3Nm
4	90°	0.3Nm
5	180°	0.1Nm
6	180°	0.05Nm

Table 1: Summary of the different DOFs characteristics

and the potentiometer is fixed on the wrist axis.

2.1.7 The seventh degree of freedom

is the gripper and consists of a hand with three fingers (one thumb and two fingers). Each finger is composed of phalanges, three phalanges for the two fingers and two phalanges for the thumb. A rotation axis is placed between each phalange and a cable plays the role of the tendon in the fingers (see Figure 10). The principal problem here was to find the required space for the motor. Since there was not enough space in the forearm, we decided to place the motor in the upper arm and transmit the motion to the fingers through cables with sheath. In order to open the fingers when the cable is released, a set of springs were placed around the axes. The spring system also compensates for the differences in the length of the path each of the fingers must follow, (see Figure 12). This system has the advantage that the fingers adapt to the form of the object they can grasp. In order to detect the end of the motor course, we placed a switch at the end of the traction system (see Figure 11).

2.2 The Eyes

For the same robot and with the same constraints as stated in Section 2, we have developed a prototype of a 3 DOFs pair of eyes (see Figure 14).

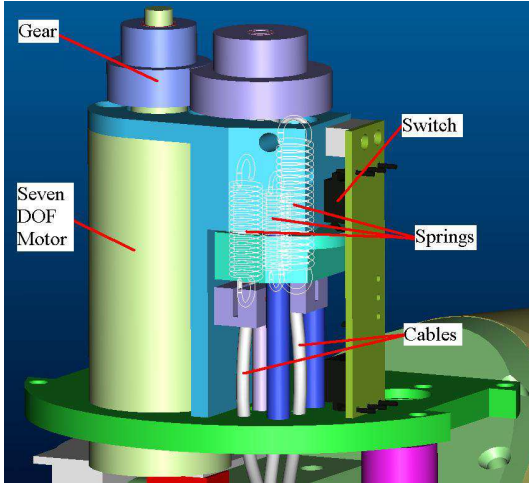

Figure 11: The traction system for the fingers cable

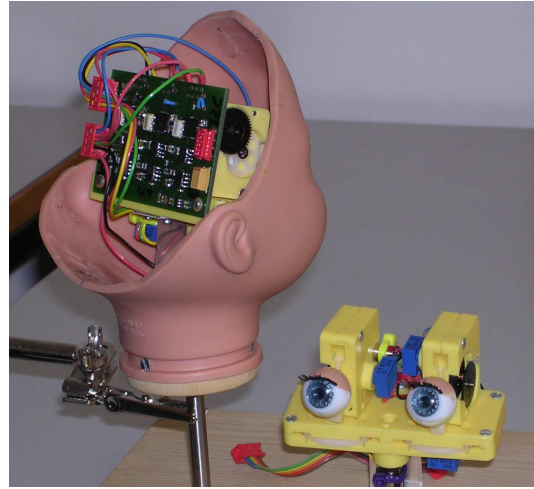

Figure 14: The eyes prototype, left in Robota's head with the electronic part

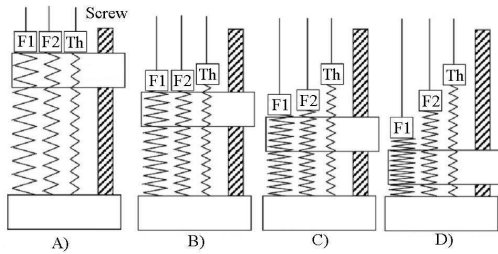

Figure 12: A) All springs are preconstraint. Thus, when the cables are released, the B) Thumb C) Finger 1 and D) Finger 2 are closed

DOF	Motors	Gears	Encoder	Electronic	Diverse	Total
1	Faulhaber 1516 A 009 SR	15A 546:1	IE2-64	Motor Driver	Potentiometer, Notched Belt	
Price (CHF)	34.50	21.00	55.00	60.00	7.15	177.65
2	Faulhaber 2224 A 009 SR	22E 369:1	IE2-64	Motor Driver	Potentiometer, Bevel Gear	
Price (CHF)	41.00	30.00	55.00	60.00	34.95	220.95
3	Faulhaber 1516 A 009 SR	15A 809:1	IE2-64	Motor Driver	Potentiometer, Ball Bearing	
Price (CHF)	34.50	21.00	55.00	60.00	39.40	209.90
4	Faulhaber 1516 A 009 SR	15A 809:1	IE2-64	Motor Driver	Potentiometer, Bevel Gear	
Price (CHF)	34.50	21.00	55.00	60.00	32.50	203.00
5	Maxon RE10	GP10A 256:1	Digital Encoder MR	Motor Driver	Potentiometer, Gear	
Price (CHF)	50.00	136.90	50.20	60.00	26.20	324.10
6	Maxon RE10	GP10A 256:1	Digital Encoder MR	Motor Driver	Potentiometer, Gear	
Price (CHF)	50.00	136.90	50.20	60.00	41.40	339.30
7	Faulhaber 1516 A 009 SR	15A 28:1	IE2-64	Motor Driver	Gear, Magnet, switch, Hall Sensors, Springs, Ball Bearing	
Price (CHF)	34.50	17.50	55.00	60.00	52.00	219.00
					Price of the Arm	1694.00

Figure 13: Cost of the arm.

One DOF drives the horizontal rotation of the two eyes and the two other DOFs drive the vertical rotation of each eye. Thus, the robot can wink but not squint! The difficult aspect of the mechanical design was to place the center of rotation at the center of each eye, in order for the eyes to move easily within the original doll head. In each eye, we have placed one "mobile phone" webcam (CCD 420x640).

The principal constraint in this project is the aesthetic of the robot. The only visible part of the prototype is the eyes (the rest of the mechanics being hidden inside the doll's head). We use real doll eyes that we modify to insert the cameras, by drilling a tiny hole through the pupil, making sure that the iris remains intact.

2.2.1 The first DOF

A Portescap motor of 8mm drives two modules containing each DOF. The transmission is a gear with two reduction layers, a special wheel, consisting in a quarter of wheel, give the output of the gear. The wheel is guided by a smooth bearing (see Figure 15). The potentiometer is placed on the intermediate axis of one of the gears.

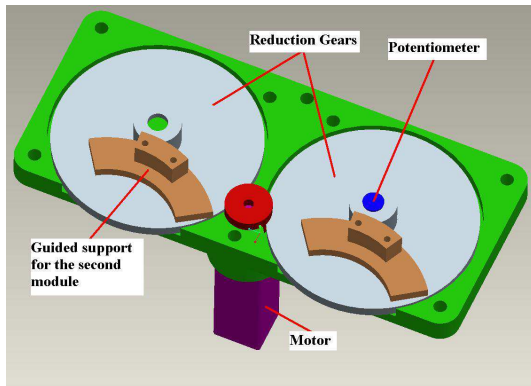

Figure 15: Horizontal rotation of the eyes

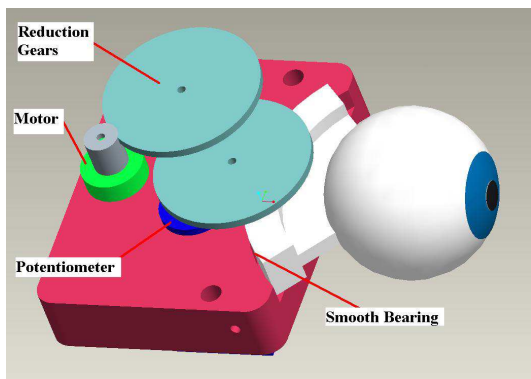

Figure 16: Vertical rotation of the eyes

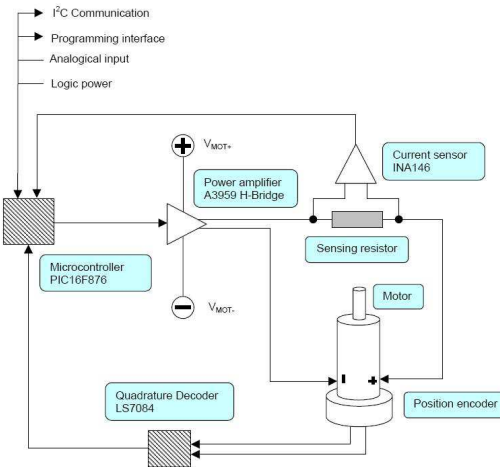

Figure 17: Schema of the motor driver module

2.2.2 The second DOF

A 6mm motor from Portescap drives the vertical rotation of the eyes. The gear has three reduction layers and a last special wheel to be able to move the eye around a fictive axis. The system is the same as that described in Section 2.2.1 (see Figure 16). The smooth bearing generates some friction. This is, however, sufficiently weak to be overcome by the motor.

3 Electronic and Control

All actuators in the arm are simple DC Motors with digital encoders. Each motor is controlled by the same *Motor Module* that allows control in position, speed and torque. To avoid having too many cables passing through the articulations, each module is placed as close as possible to the motor it drives. The PC communicates with all the modules via I2C. In total, we have at maximum 6 wires running through any articulation: 2 for the motors power supply, 2 for the logic power supply and 2 for the I2C communication.

3.1 Hardware

The motor module is basically composed of a microprocessor, a H-bridge amplifier, a current sensor and a quadrature decoder (see Figure 17). For each module, the H-bridge and the current sensor must

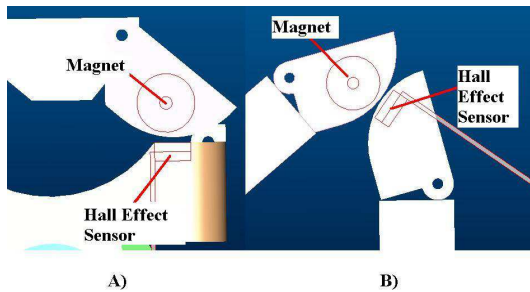

Figure 18: A) Second finger B) First fingers and thumb

be adapted to the power of the motor it must drive. We use two types of H-bridges, that can supply a current of up to 1A and 3A respectively. A complete motor module has a surface of $\sim 7\text{cm}^2$. Two modules driving the 1st and 2nd DOFs are fixed inside the shoulder; the module driving the 3rd DOF is located inside the upper arm, while the remaining two modules are fixed in the front arm.

3.2 Microcontroller

The microcontrollers of the motor modules are programmed in assembly. The 6 controllers of the arm use the motor encoder to do the control and initialize the encoder with the potentiometer. In the gripper, the absolute position can not be given by a potentiometer because of the linear movement of the cable. In this case we use two switches (see Figure 11) at both ends of the traction system to determine the start and end of the traction. Additionally, we placed one electromagnetic sensor and its pending magnet on each pair of opposite fingers to determine when the fingers are closed or not (see Figure 18). The controller, driving the eyes, use the potentiometers to control the motors in position, as there are no encoders on the motors. The eyes are controller by a basic PID controller.

4 Discussion and Conclusion

This paper presented a prototype of a miniature 7 degrees of freedom arm and a miniature 3 degrees of freedom pair of mobile eyes for the mini humanoid robot Robota. To our knowledge, this is the sole example of an arm and pair of eyes of this

size, in which all the electronics and mechanics are contained inside the prototype.

While the majority of large size humanoid robots have either 6 or 7 DOFs arms, see, e.g., ARMAR at the University of Karlsruhe [9], WABIAN at Waseda university [10], Saika at Tohoku university [11] or MIT's Cog, all small size humanoid robot arms have at most 4 DOFs: 5 DOFs arm + gripper for HOAP-2 and 6 DOFs (arm + gripper) for QRIO. Moreover, while most humanoid robots have binocular eyes, usually mounted with cameras, none of the state-of-the-art miniature humanoid robots have decoupled eyes.

New developments are constantly on the go to augment Robota's sensory, motor and cognitive capabilities. A three DOFs neck prototype is under construction and we plan to tackle the design and construction of a three DOF torso this coming fall.

5 Acknowledgments

This work was supported in part by the Swiss National Science Foundation, through grant no 620-066127 of the SNF Professorships program and by the European Commission Division FP6-IST Future and Emerging Technologies under Contract FP6-002020, EU Integrated Project COGNIRON.

References

- [1] Y. Sakagami, R. Watanabe, C. Aoyama, S. Matsunaga, and K. Higaki, N. Fujimura, "The intelligent asimo: System overview and integration," in *IEEE/RSJ Intl Conference on Intelligent Robots and Systems*, 2002.
- [2] M. Fujita, Y. Kuroki, T. Ishida, and T. Doi, "A small humanoid robot sdr-4x for entertainment applications," in *IEEE/ASME Intl Conference on Advanced Intelligent Mechatronics*, 2003.
- [3] C. Plaisant, A. Druin, C. Lathan, K. Dakhan, k. Edwards, J. Vice, and J. Montemayor, "Storytelling robot for pediatric rehabilitation," in *ASSETS'00*, 2000.
- [4] A. Billard, "Robota: Clever toy and educational tool," *Robotics & Autonomous Systems*, vol. 42, pp. 259–269, 2003.

- [5] —, “Drama, a connectionist architecture for on-line learning and control of autonomous robots: Experiments on learning of a synthetic proto-language with a doll robot,” *Industrial Robot*, vol. 26:1, pp. 59–66, 1999.
- [6] A. Billard, Y. Epars, G. Cheng, and S. Schaal, “Discovering imitation strategies through categorization of multi-dimensional data,” in *Proceedings of the 2003 IEEE/RSJ Intl. Conference on Intelligent Robots and Systems*, 2003.
- [7] B. Robins, K. Dautenhahn, R. te Boekhorst, and A. Billard, “Effects of repeated exposure of a humanoid robot on children with autism,” *S. Keates, J. Clarkson, P. Langdon and P. Robinson (eds), Designing a More Inclusive World. London Springer-Verlag, pp.225-236*, 2004.
- [8] A. Billard, Y. Epars, S. Calinon, G. Cheng, and S. Schaal, “Discovering optimal imitation strategies,” *Robotics & Autonomous Systems*, vol. 43:2-3, pp. 69-77, 2004.
- [9] K. Berns, T. Asfour, and R. Dillman, “Armar-an anthropomorphic arm for humanoid service robot,” in *IEEE Intl Conference on Robotics and Automation*, 1999.
- [10] H. Lim and A. Takanishi, “Waseda biped humanoid robot realizing human-like motion,” in *IEEE Intl Conference on Systems, Man, and Cybernetics*, 2000.
- [11] A. Konno, N. Kato, S. Shirata, and M. Furuta, T. Uchiyama, “Development of a light-weight biped humanoid robot,” in *IEEE/RSJ Intl Conference on Intelligent Robots and Systems*, 2000.