

7/6/02

StreamCom: Business Analysis and System Design Specification

(Deliverables: M2, M7)

Technical Report #

IC/2002/037

Pavel Balabko
Hien Dat TRAN
Alain Wegmann

*Institute for computer Communications and Applications
Swiss Federal Institute of Technology – Lausanne
EPFL-DSC-ICA
CH-1015 Lausanne, Switzerland*

{ pavel.palabko@epfl.ch,
alain.wegmann@epfl.ch,
hiendat.tran@epfl.ch }

September 2001

Table Of Contents

STREAMCOM: BUSINESS ANALYSIS AND SYSTEM DESIGN SPECIFICATION	1
TECHNICAL REPORT V.2 (DELIVERABLES: M2, M7)	1
1. INTRODUCTION.....	5
2. BUSINESS ANALYSIS SPEC	7
2.1. COLLABORATION MODEL.....	7
2.2. COLLABORATION SPEC	9
2.2.1. <i>Sell and Get a Service</i>	9
Sell and Get a Service	11
Sell and Get a Service Activity Diagram.....	12
Sell a Service.....	13
Actors in Sell a Service.....	15
Get a Service.....	15
Actors in Get a Service	17
“StreamCom General Architecture”: an Example of the Business Scenario	19
3. IT SYSTEM DESIGN.....	21
Activity Diagram : Choose Service	22
Activity Diagram: Buy Online Stream and Ticket Distribution.....	23
Conceptual Model : ClientSystem View-Point	24
Conceptual Model : RetailerSystem View-Point	26
Conceptual Model : BSystem View-Point.....	28
Conceptual Model : KeyServer View-Point.....	29
Conceptual Model : Ticket.....	30
3.1.1. <i>Get a Service</i>	31
Activity Diagram : Get a Service in particular	31
Pattern of Get a Service	32
Conceptual Model : ClientSystem View-Point	34
Conceptual Model : ContentSystem View-Point	36
Conceptual Model : KeyServer View-Point.....	38
Conceptual Model : BSystem View-Point.....	40
3.1.2. <i>Payment</i>	42
Payment	43
4. IT SYSTEM IMPLEMENTATION.....	44
4.1. SELL AND GET A SERVICE	44
4.1.1. <i>Sell a Service</i>	44
Sequence Diagram : Choose a Service	44
Sequence Diagram : Buy a Service.....	45
Logical Design Class Diagram : Client System View-Point	46
Logical Design Class Diagram : RetailerSystem View-Point	48
Logical Design Class Diagram : BSystem View-Point	50
Logical Design Class Diagram : KeyServer View-Point	51
Interfaces in Get a Service.....	52
4.1.2. <i>Get a Service</i>	53
Sequence Diagram : Get a Service	53
Logical Design Class Diagram : ClientSystem View-Point.....	54
Logical Design Class Diagram : ContentServer View-Point	56
Logical Design Class Diagram : KeyServer View-Point	58
Interfaces in Get a Service.....	60

4.1.3. Redeem 61
Redeem 61

1. Introduction

This report represents the work of several people within the framework of the StreamCom project. This work, done together with our colleagues from the University of St. Gallen¹, covers the modeling part of StreamCom. The aim of the modeling part of the StreamCom project includes the following goals (see Figure 1):

- Specify the main business actors, business activities and business environment for the StreamCom project (done by ICA).
- Specify the Generic Components model for streamed information distribution (done by MCM).
- Provide a system design that specifies one of the possible system's behaviors that is based on the StreamCom Business Analysis and use the StreamCom Generic Component model (done by ICA).

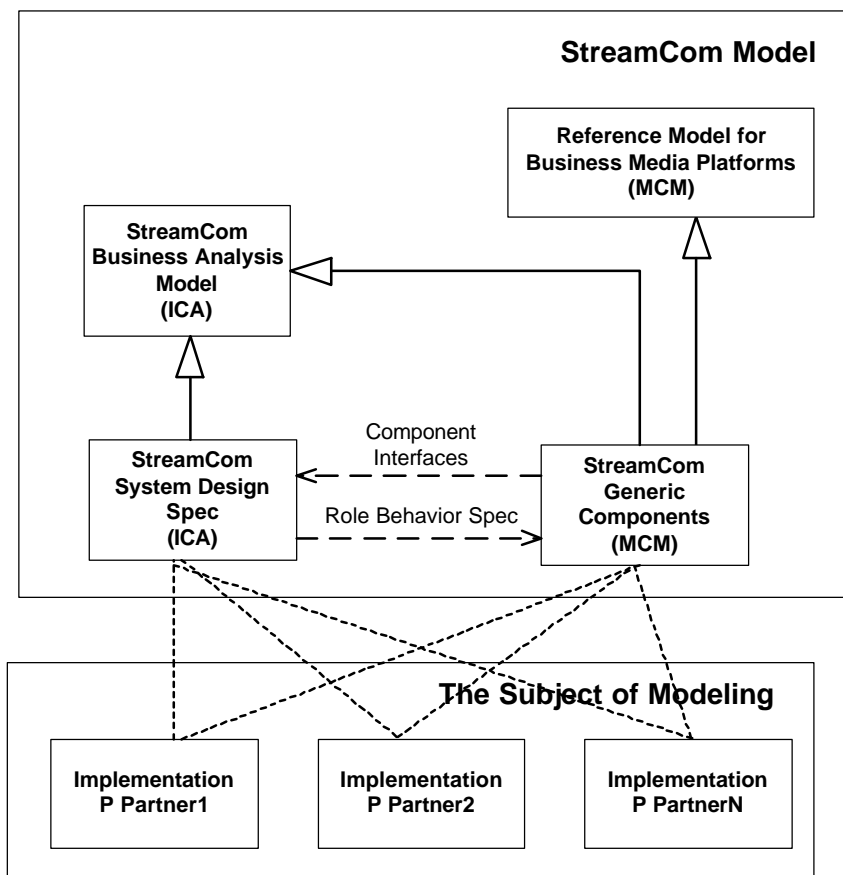

Figure 1 Main Modeling Deliverables

¹ See: Markus Greunz, Katarina Stanoevska-Slabeva « Generic Components that enable Business Models for Content Streaming», Universität St. Gallen – Hochschule für Wirtschafts-, Rechts- und Sozialwissenschaften (HSG)

The StreamCom Business Analysis Model done by ICA uses generic actors and generic business actions (or collaborations), represented in the StreamCom Generic Components Model. According to the General System Theory², any “system is inseparable from its environment”. This means that the consideration of the environment of a system is important in understanding the system itself. That is way one of the main goals of the business analysis is to consider the environment of systems that can be build on the base of the StraemCom platform. In this work we have considered the following business actors in the StreamCom environment: Ads Provider, Stream Owner, Stream Publisher, Monitor Company (see the Section 2.1).

The StreamCom Generic Components part is done by MCM. “Components of a generic business model can be viewed as a template for specific business models which factors out a set of assumptions that all specific business models derived from it will have in common while leaving open some aspects that are to be decided on a case by case basis”

The SteamCom System Design Specification³ describes one of several possible design choices that can be done based accordingly to StramCom Business Analysis model. The presented here design corresponds to the implementation of the demonstrator done by programming partners. The SteamCom System Design Specification complements the Generic Component Model. While the Generic Components model specifies components for the StreamCom platform, the System Design model specifies the example of system behavior that can be built using such components.

Let’s also note that this report as well as the report provided by MCM does not specify all the technical details of implementations provided by StreamCom programming partners. Specification artifacts allow to understand the overall project ideas and to see how technical solutions from different partners can be integrated into one system.

This report was automatically was build from the UML model done in the Rational Rose case tool⁴. The structure of this report is the following: In section 2 of this report we show the specification of the StreamCom Business Analysis Model (Deliverable M.2 accordingly to the plan of the project). In section 3 of this report we show the implementation model (Deliverable M.7 accordingly to the plan of the project).

² L. Von Bertalanffy, *General System Theory*. New York: George Braziller, 1968

³ The System Design specification still can have some minor changes till the end of the project.

⁴ To get the Rational Rose model please send a request to Pavel Balabko: pavel.balabko@epfl.ch

2. Business Analysis Spec

The Business Analysis Specification represents the result of the analysis of several existing systems dealing with streaming of the information over the Internet and the environment of these systems. Here we show just only the resulting model that gives the business context for systems based on the StreamCom framework. For details on the analysis see <http://in3www.epfl.ch/~pbalabko/Projects/StreamCom/AsIsToBeModels.pdf>

2.1. Collaboration Model

Business Collaboration Model

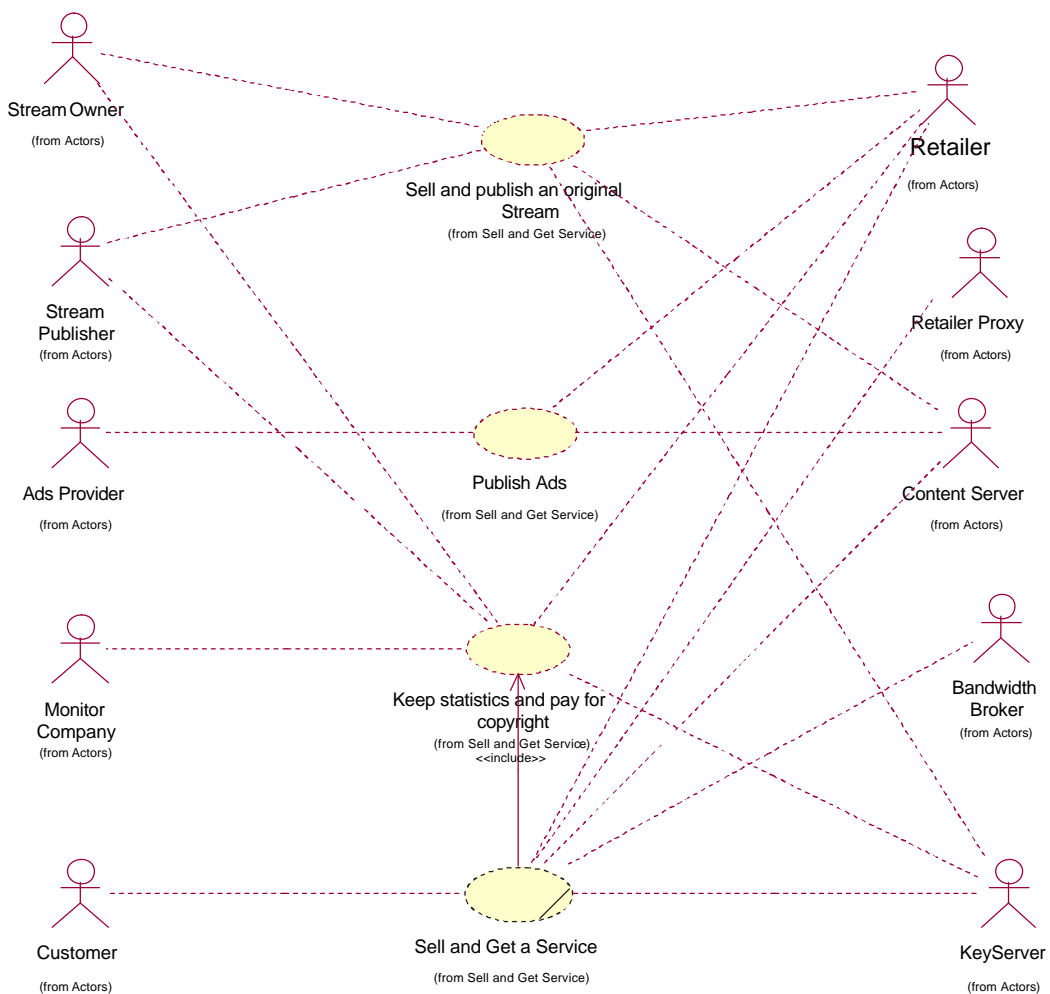

Glossary

Ads Provider

An Ads Provider provides advertisement to Retailer in order to give it to Customer

Stream Owner

A Stream Owner owns streams he wants to sell on the market

Stream Publisher

A Stream Publisher prepares streams for reselling

Monitor Company

A Monitoring Company observes all the traffic activity of selling streams

Customer

A Customer is anyone who is interested in getting or previewing a Stream

KeyServer

A Key Server works like a Digital Righth Manager. It is responsible for the digital keys distribution used for encrypting and decrypting online streams

Bandwidth Broker

A BandWidth Broker BB is responsible for the bandwidth reservation

Content Server

A Content Server disseminates service to Customer by broadcasting encrypted message which is a part of a stream

Retailer

A Retailer sells streams (provided by the Content Provider) to Customer

Retailer Proxy

Retailer Proxy goal is to collect offers from different customers and matching them in an optimal way. This optimization results in SLA/OLAs messages sent to a retailer.

2.2. Collaboration Spec

2.2.1. Sell and Get a Service

Documentation:

Purpose:

The Purpose of this collaboration is to sell a Service from a Retailer to a Member. The service can be provided in the form of CDs, DVDs or on-line streams.

Participants:

One Member (Customer) who buys the stream

One Retailer who sells the Stream

Retailer Proxy who collects and optimizes customer requests.

One Content Server who broadcasts the stream (in case of Online Stream)

One KeyServer who sells keys for security (in case of Online Stream)

One Bandwidth Broker who reserves for bandwidth requirement (in case of Online Stream)

Pre-Conditions:

ServiceCatalog exists

Credit card number exists

Policies:

The Member should be provided with an on-line stream version of the service when he buys it on CD or DVD.

Customer can get on-line service just on the specified computer (due to reservation)

A Stream can include ads from the Ads provider

The Bandwidth Broker should reserve required bandwidth for on-line stream.

The Retailer has the right to start a bandwidth reservation

Relationships between Retailer, Content Server, Key Server, Bandwidth Broker exist.

Non-functional Requirements (Security Requirements):

Any exchange of information between Participants should be done in a secure way.

Customer and Retailer should exchange money against ticket using fair-exchange protocol.

Retailer and Content Server should be able to identify clients that using provided services illegally.

Post-condition:

PC1. A Customer became a Member (for the first time only)

PC2. A Customer got a Service (content and keys).

PC3. A Retailer got money from the Customer.

PC4. A Content Server, A Key Server and A Bandwidth Broker got money from the Retailer for co-operatively providing stream content to a customer (by means of redeeming tickets).

PC4. A Client got Service Level Agreement (SLA)

PC5. A Retailer Proxy got Operational Level Agreement (OLA)

PC6. A KeyServer got a ticket and micro-payments from the client.

PC7. A Retailer got confirmation of QoS with OLA.

Note: The stream can be copied to the user device like CD, or MP3 player (if the customer does not have any copy restrictions).

Sell and Get a Service

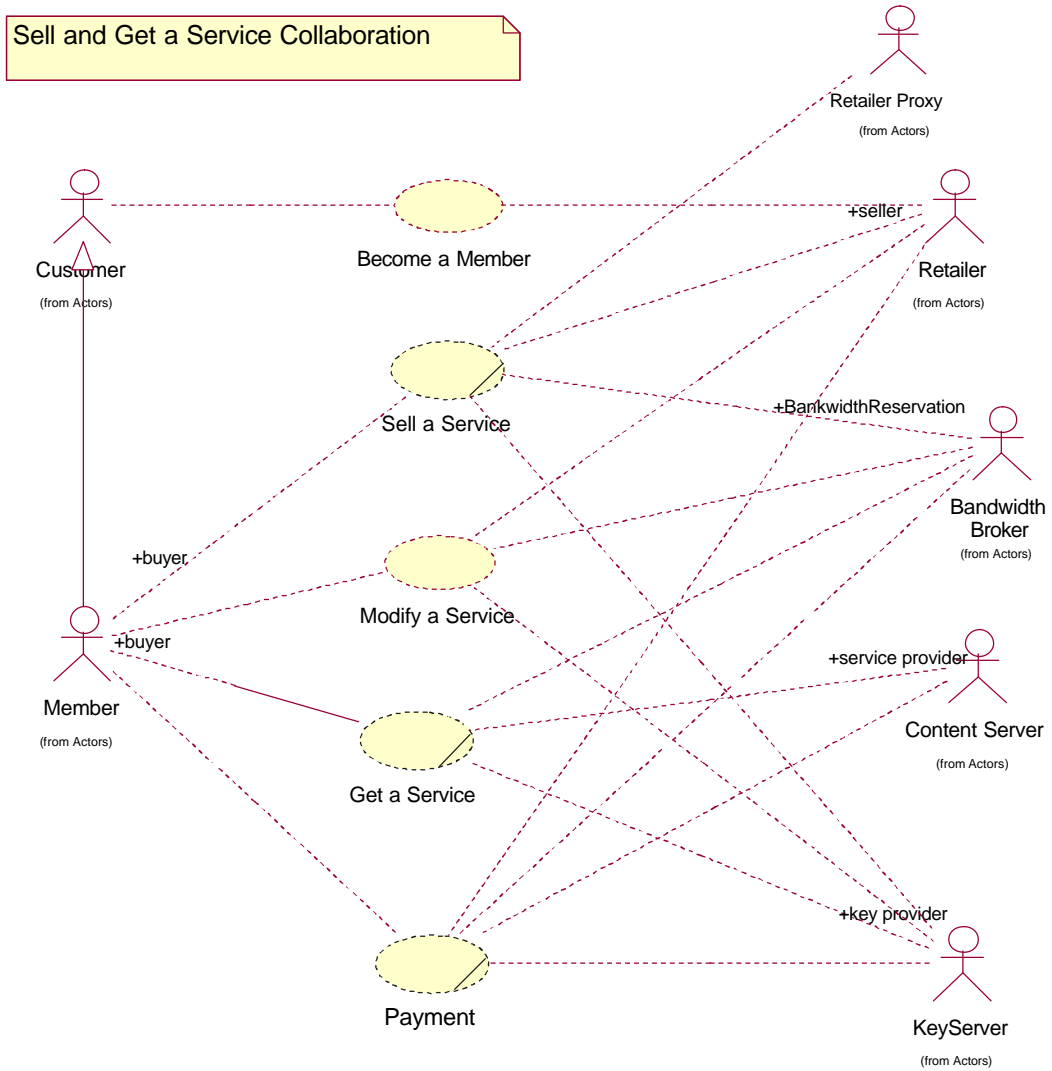

Sell and Get a Service Activity Diagram

Main Activites of Sell and Get a Service

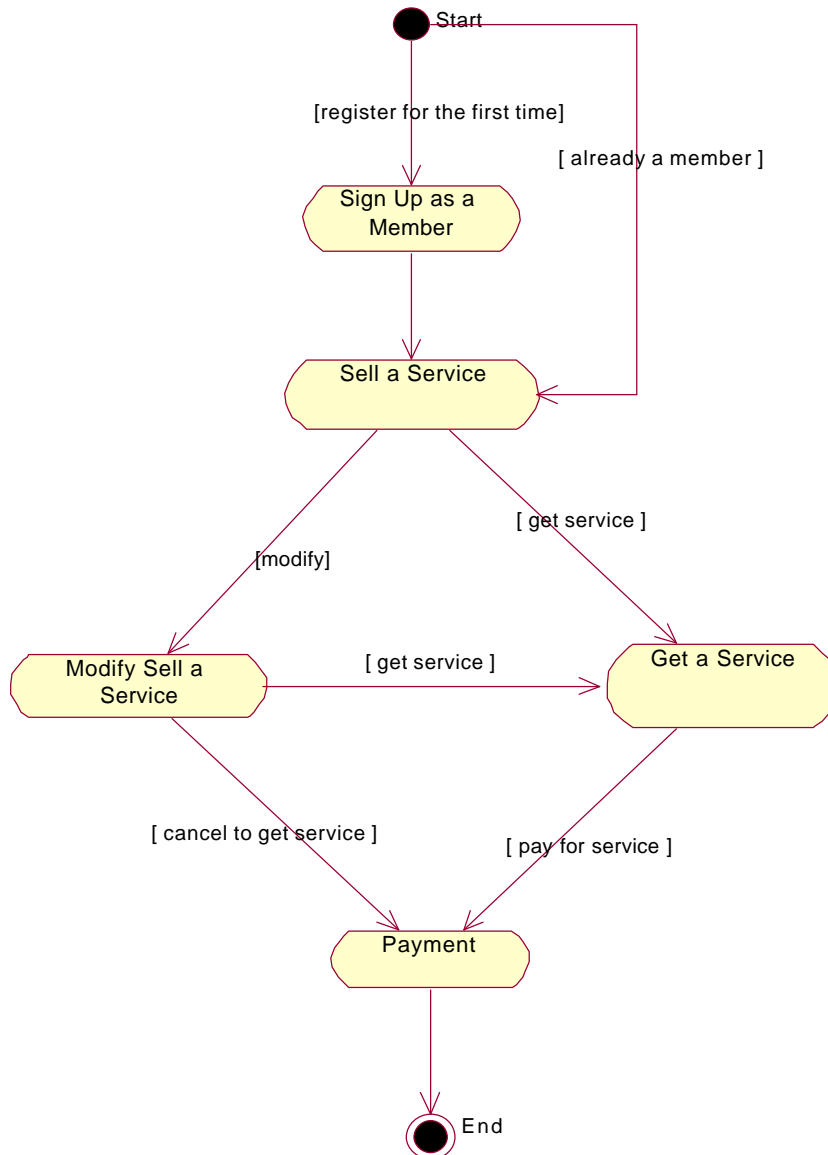

Sell a Service

Documentation:

Purpose:

The purpose of this collaboration is that a Member gets a Service (on-line stream Ticket or hard copy) of his choice from a Retailer and pays for it with a credit card. In the case of an on-line stream, the Member also gets a Ticket and a key that allows him to start the Video

Parameters:

Identification information (MemberId and Password, RetailerId, ContentServerId ...)
 Name of the service (video or TV channel)
 Service information
 Bandwidth require
 Payment information (ex: credit card number).

Pre-Conditions:

ServiceCatalog exists
 Relationships between Retailer, Content Server, Key Server, Bandwidth Broker exist

Post-Conditions:

A Customer became a member of Retailer (for the first time only)
 A Member got a Ticket and key
 A keyServer got a TicketID (or Ticket)
 A bandwidth reservation is done by Bandwidth Broker
 A Retailer got a reference to the Customer's paying facilities (credit card, or address for issuing a bill)
 A customer got hard copy (not mandatory)

Non-functional Requirements (Security Requirements):

Any exchange of information between Participants should be done in a secure way.
 Customer and Retailer should exchange money against ticket using fair-exchange protocol.

Basic Course of Events:

1. [A new Service Provider] registers at Retailer.
2. [Client] Registers in the system.
3. [Retailer] Sends information (Mainly it is some advertisement information, some bonuses, special offers, based on the UserProfile).
4. [Member] Chooses a service title and type (on-line stream, DVD, CD) and specifies the number of minutes/views/copies. The Member can see the service description and preview if necessary.
5. [Client] sends requests SLA message to RetailerProxy.
6. [RetailerProxy] sends a OLR message to Retailer.
7. [Retailer] sends request for QoS accordingly to OLR to BB

8. [Bandwidth Broker] Setup bandwidth reservation and sends confirmation message to Retailer.
9. [Retailer] sends the OLA message to RetailerProxy and price information to Client
10. [RetailerProxy] sends the SLA message to Client
11. [Client] Enters payment information (credit card number or address for issuing a bill).
12. [Retailer] create a Ticket and sends a Ticket to Customer.

Actors in Sell a Service

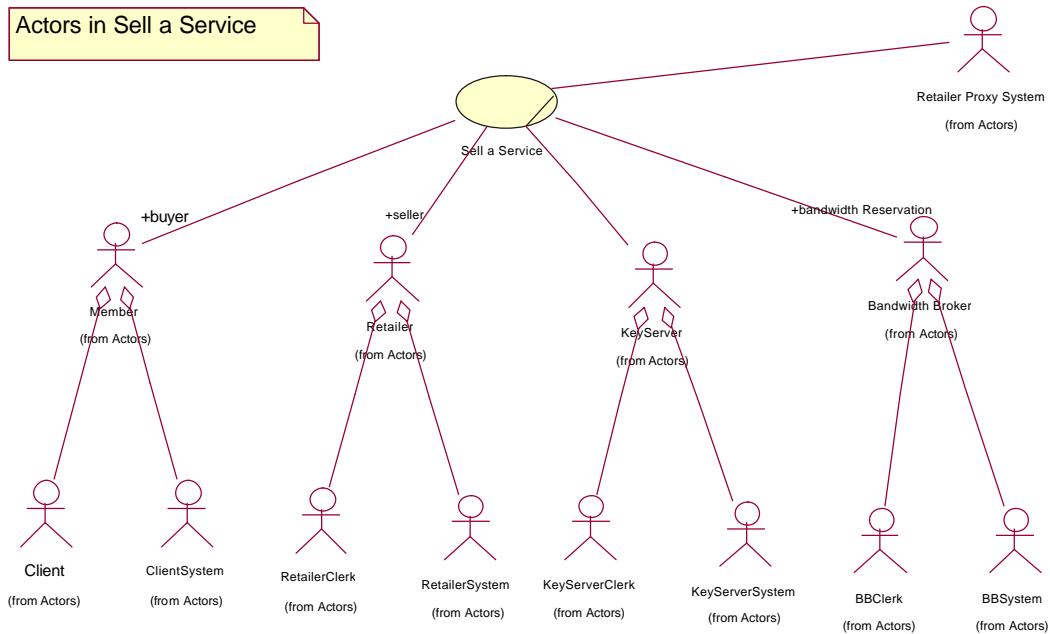

Get a Service

Documentation:

Purpose:

The Purpose of this UC is to get a Service bought in the "Buy a Service" UC and specified by the TicketId. A customer can get the service in several pieces that are broadcasted by the Content Server.

Note: A customer can get his Service (stream) in the "hard copy" (in form of CD, DVD etc). The ticket is not used in that case.

Parameters;

TicketId
Ticket, Key

Pre-Conditions:

Customer had a Ticket and key
Content server had an Online-Service
Bandwidth between Content server and Customer is ensured

Post-Conditions:

Customer got/viewed an On-line Service
KeyServer got Ticket and Micro-payments
Bandwidth reservation is deleted

Non-functional Requirements (Security Requirements):

Any exchange of information between Participants should be done in a secure way.
Retailer and Content Server should be able to identify clients that using provided services illegally.

Main Course of Events:

1. [Customer] Sends the Ticket to the KeyServer of Content Server
2. [Customer] Sends micro-payments to Keyserver
3. [KeyServer] Sends decryption key to Customer
4. [Customer] Receives and decrypts messages (content)
5. Repeats event 2 – 4

[1-5] Content Server broadcasts the content

[1-5] We ISP supports QoS for the Customer

Actors in Get a Service

Documentation:

Actors in Get a Service

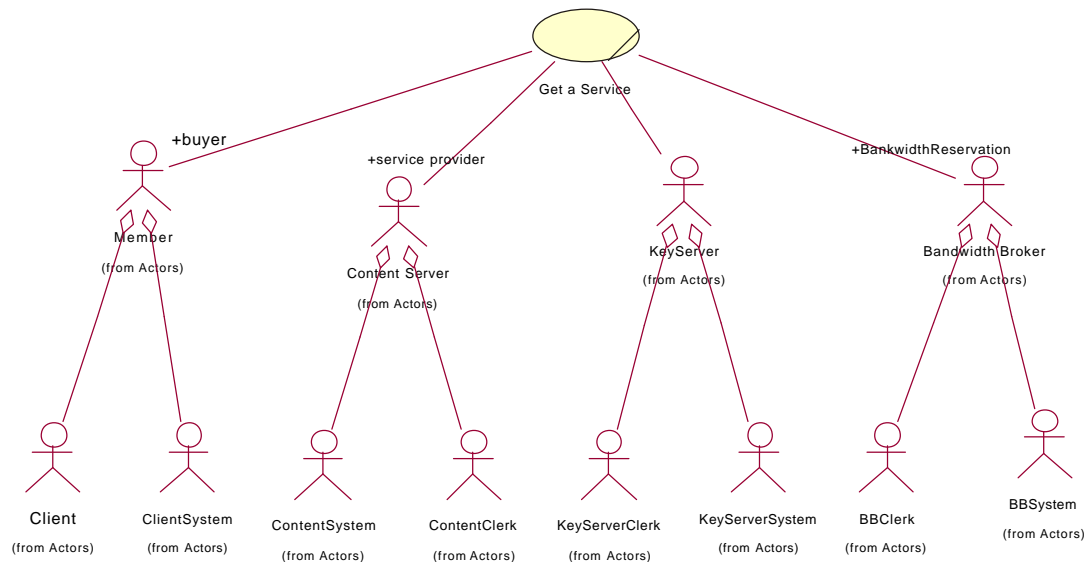

Payment

Purpose:

The Purpose of this UC is that the Retailer redeem money to KeyServer, Content Server and Bandwidth Broker

Parameters;

The last second half of micropayment token

Pre-Conditions:

Key Server got Ticket and micro-payment tokens

Post-Conditions:

KeyServer got money from Retailer

ContentServer got money from Retailer

Bandwidth Broker got money from Retailer

Main Course of Events:

1. [KeyServer] Sends the Ticket identifier and the last received micro-payment token to Retailer.

2. [Retailer] Verifies the Ticket and the last micro-payment token

3. [Retailer] Calculates redeem money correspondent to Ticket and the last half token
4. [Retailer] Pays for KeyServer, ContentServer, RetailerProxy and Bandwidth Broker.

Actors in Payment

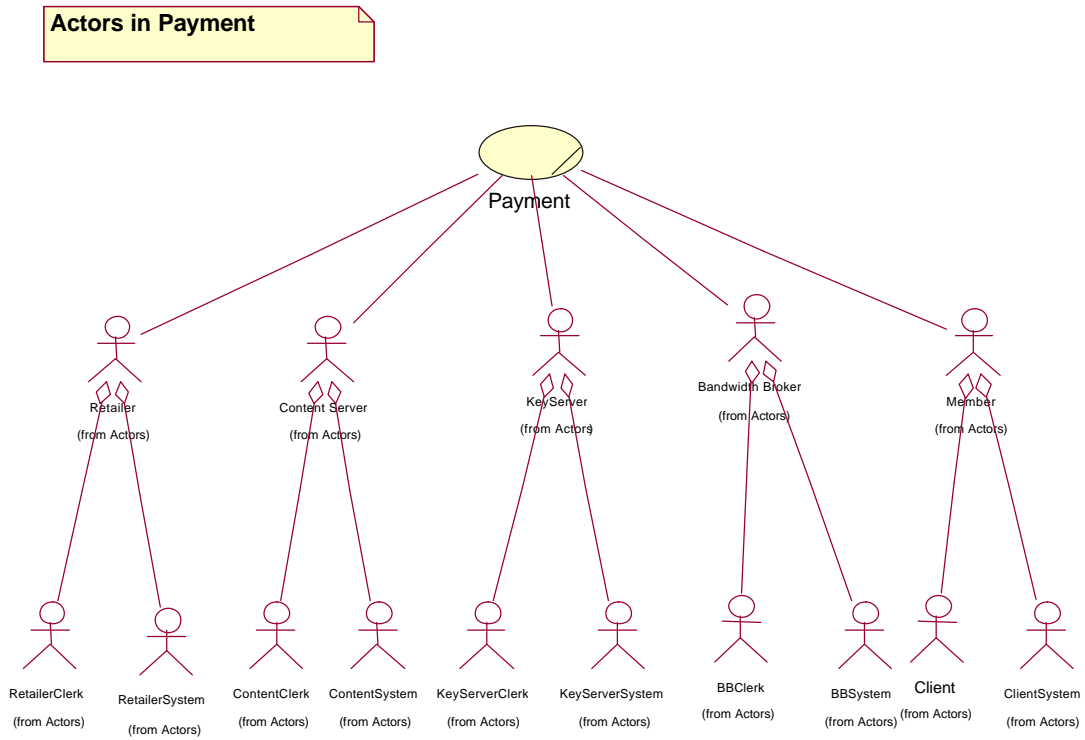

“StreamCom General Architecture”: an Example of the Business Scenario

The following collaboration diagram (instance level) represents a possible scenarios based on “Sell a service”, “Get a Service” and “Payment” Collaborations. This typical scenario gives the general understanding of the main StreamCom Systems and the way how these system collaborate together.

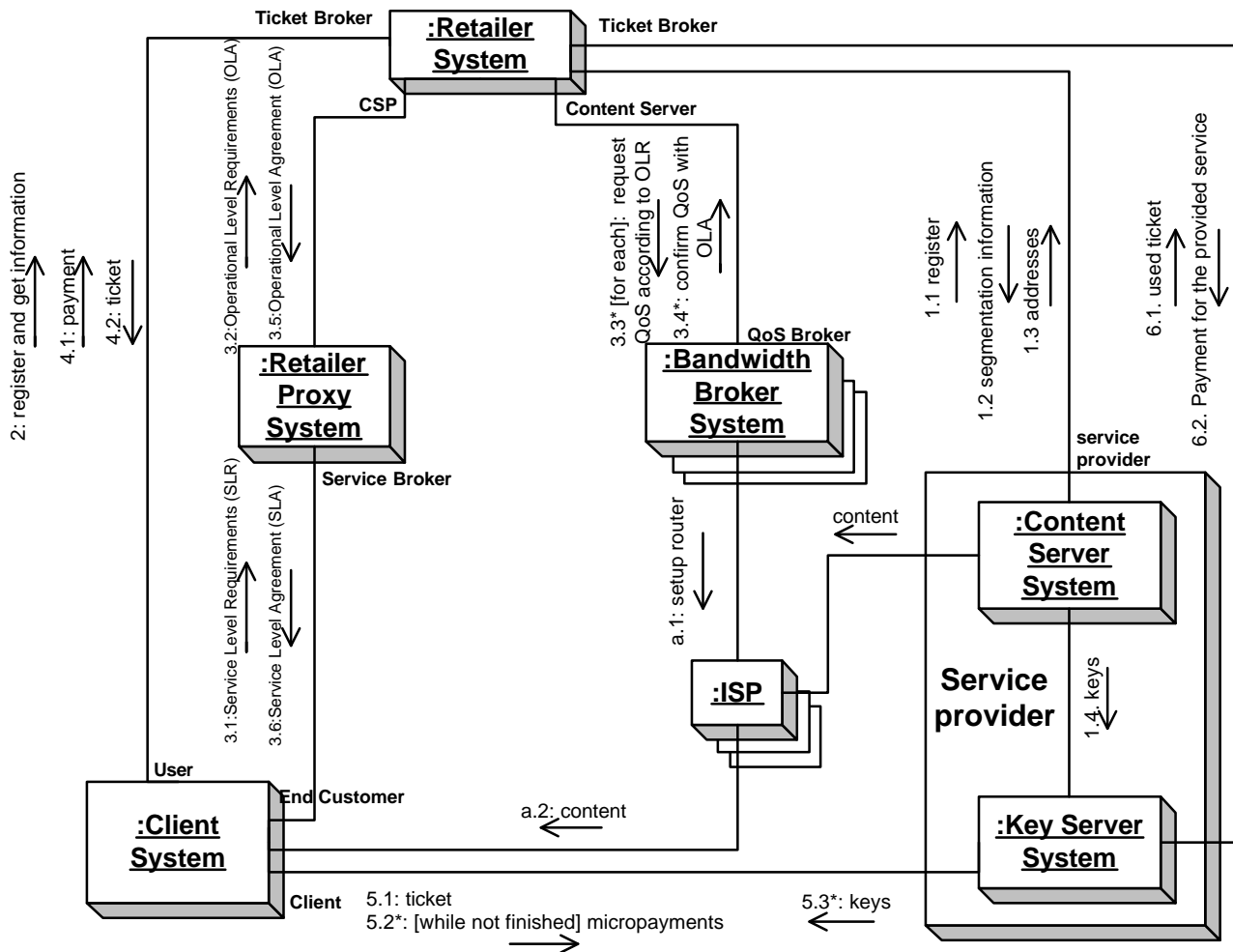

The following collaboration diagram (specification level) specifies the main business systems, they relations and cardinalities.

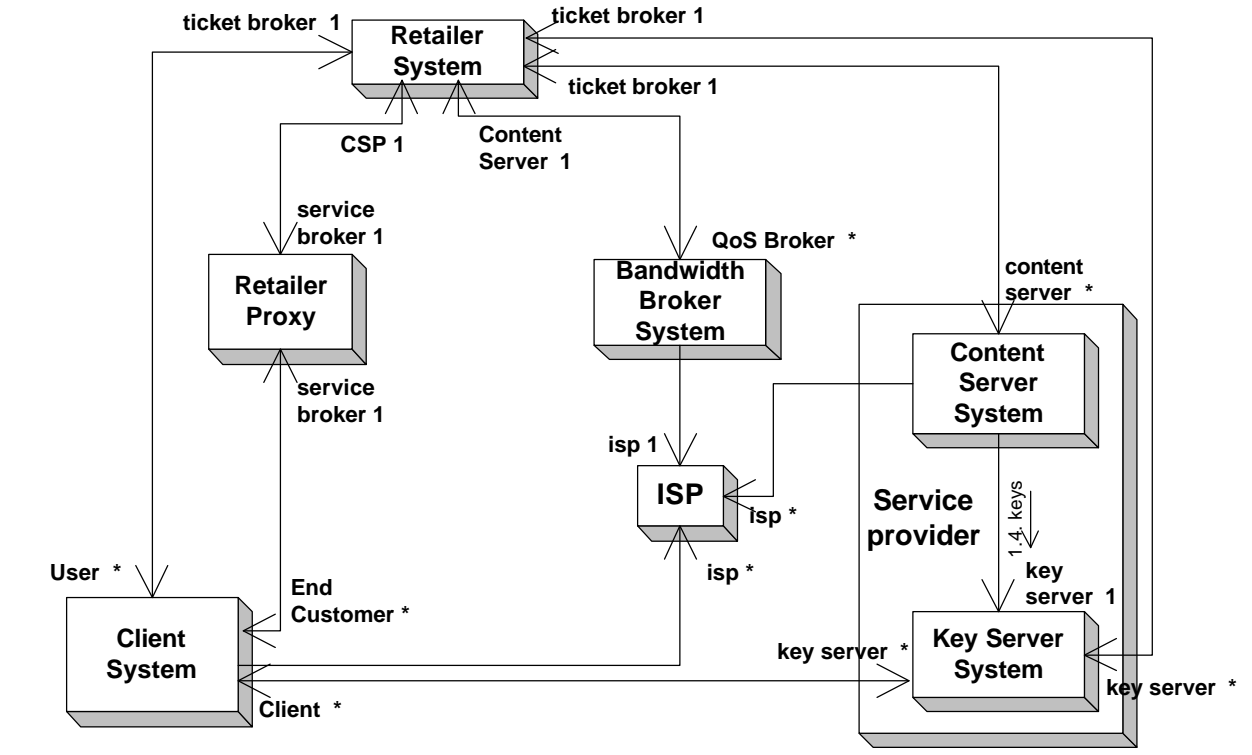

3. IT System Design

The System Design in the StreamCom project (see Figure 2) represents the composition of 5 subsystems implemented by different programming partners. The specification of each subsystem includes the behavior (done with activity diagrams here) and state (done with class diagrams here) specifications.

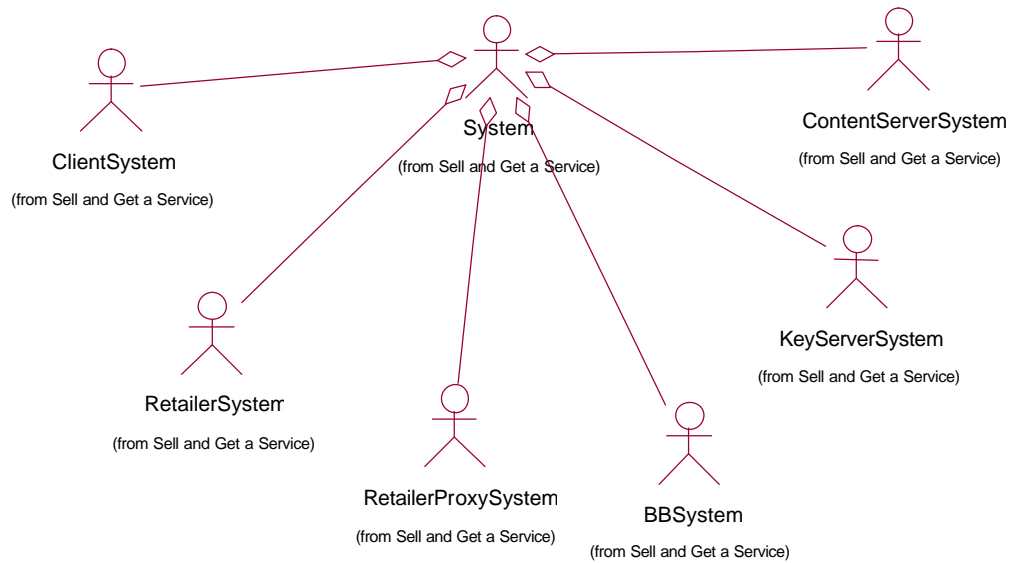
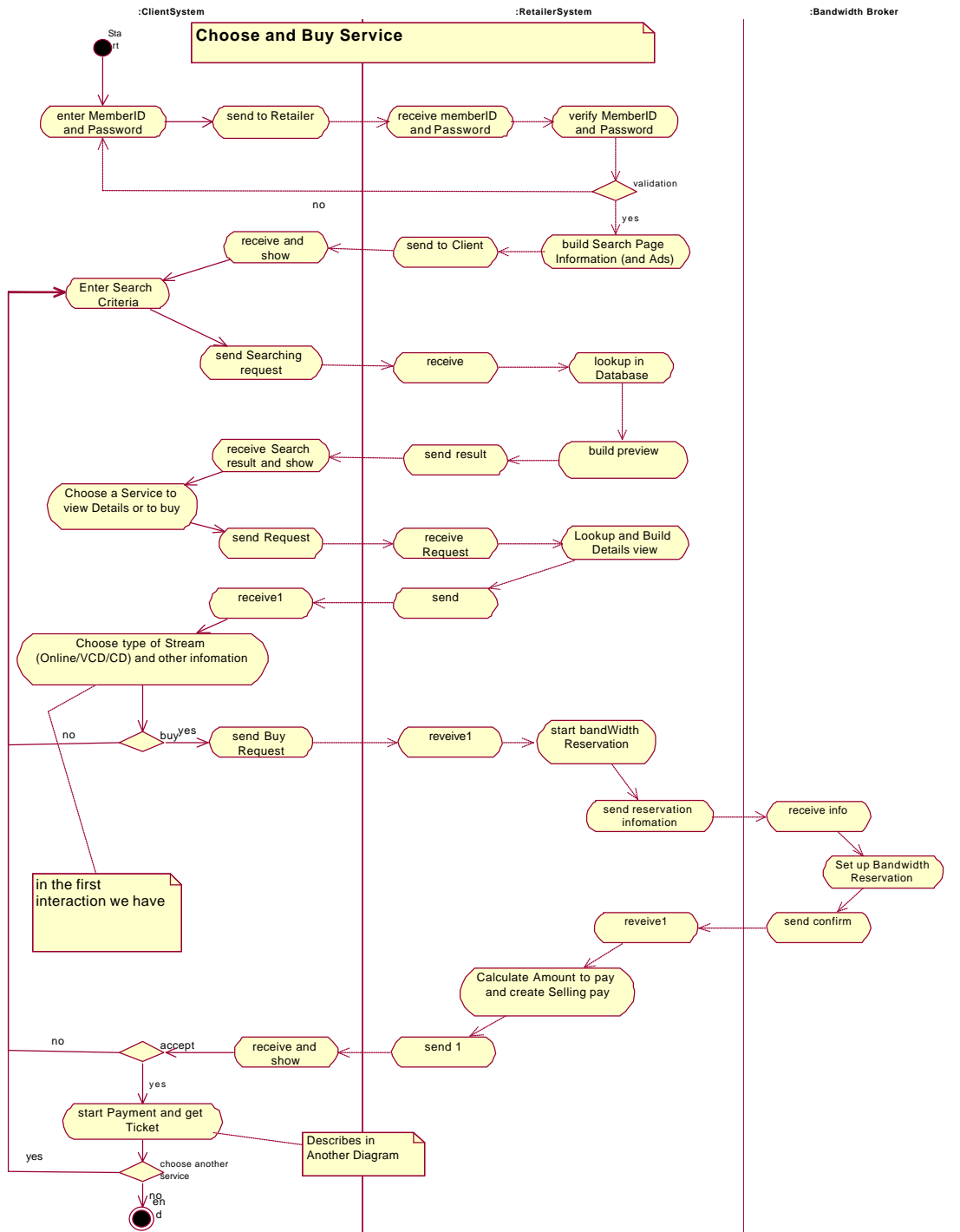
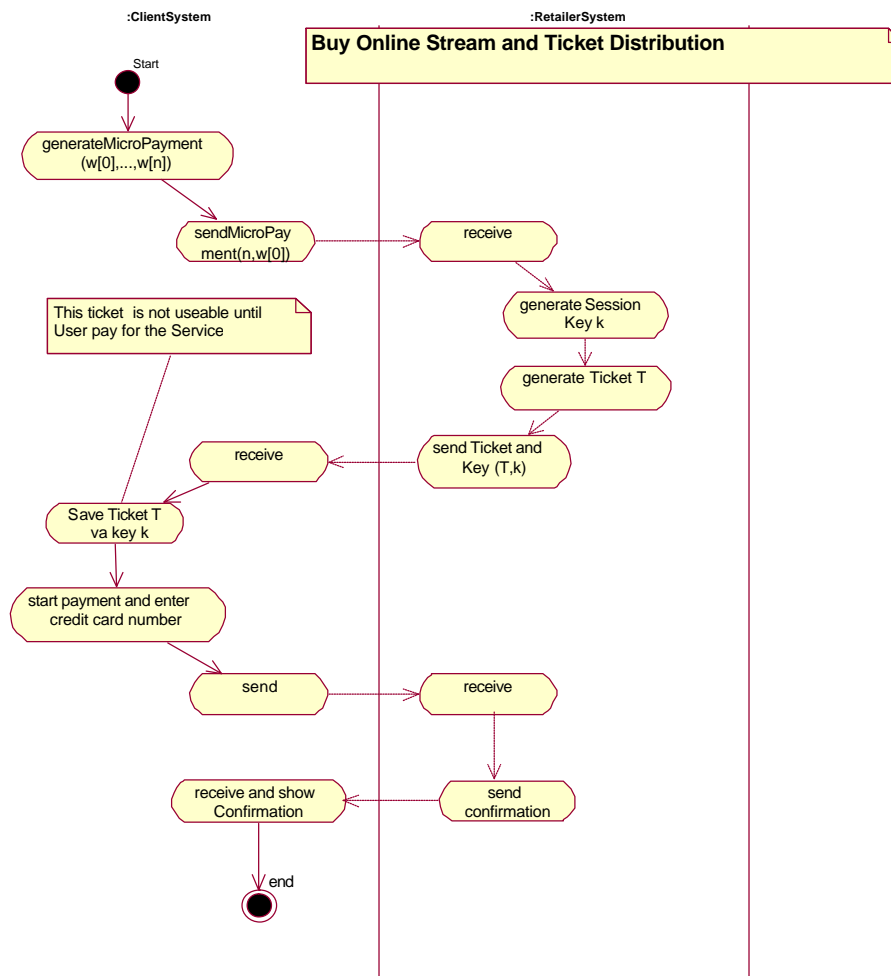

Figure 2 System in StreamCom Project

Activity Diagram : Choose Service



Activity Diagram: Buy Online Stream and Ticket Distribution



Conceptual Model : ClientSystem View-Point

Conceptual Model : ClientSystem View-Point > Buy a Service

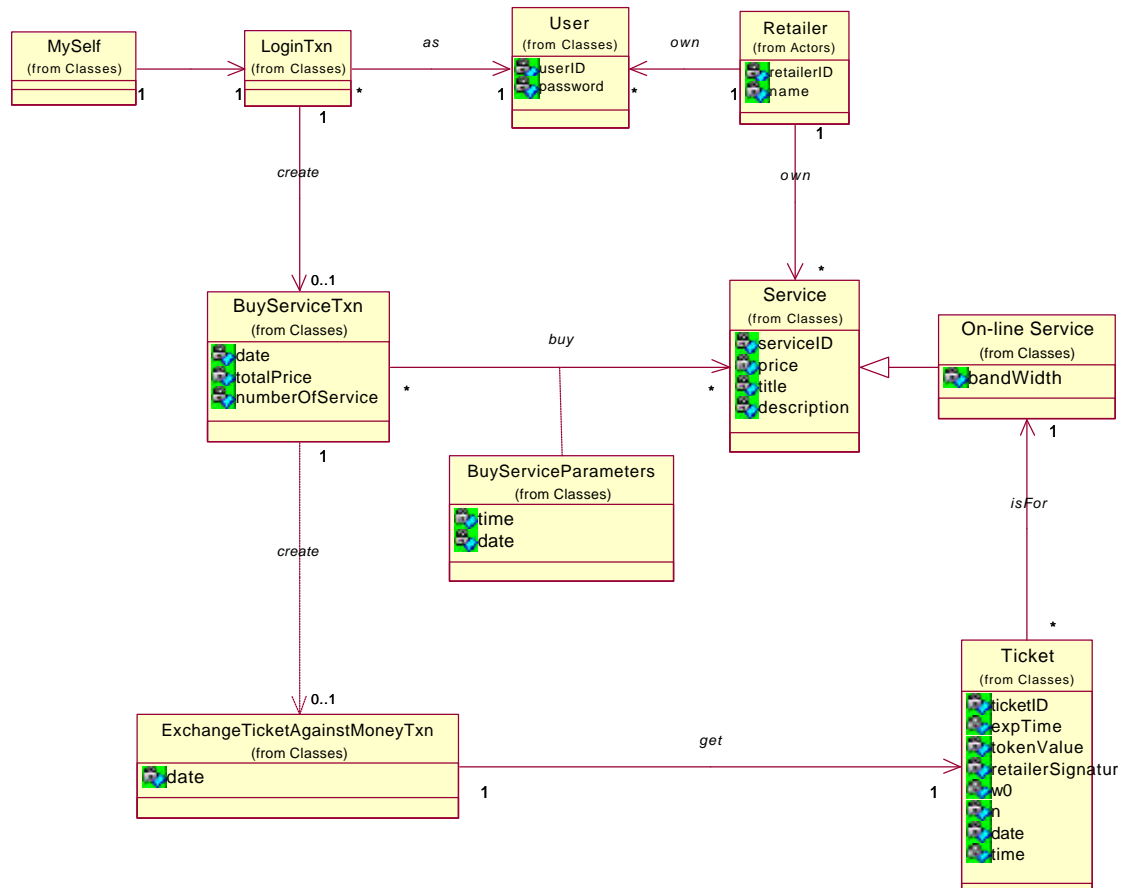

Glossary

BuyServiceParameters

Concept representing some information when buy a Service

On-line Service

Concept representing a Service in form of an Online Service

MySelf

User

Concept representing one User of the System, i.e. a Member

Retailer

A Retailer sells streams (provided by the Content Provider) to Customer

Ticket

Concept representing a ticket that is used to get an online Service

LoginTxn

Concept representing information regarding the action of a Customer login on the System

Service

Concept representing any kind of Service

ExchangeTicketAgainstMoneyTxn

Concept representing information regarding the action of buying Ticket for an online service

BuyServiceTxn

Concept representing information regarding the action of buying Services

Conceptual Model : RetailerSystem View-Point

Conceptual Model :
RetailerSystem View-Point > Sell a Service

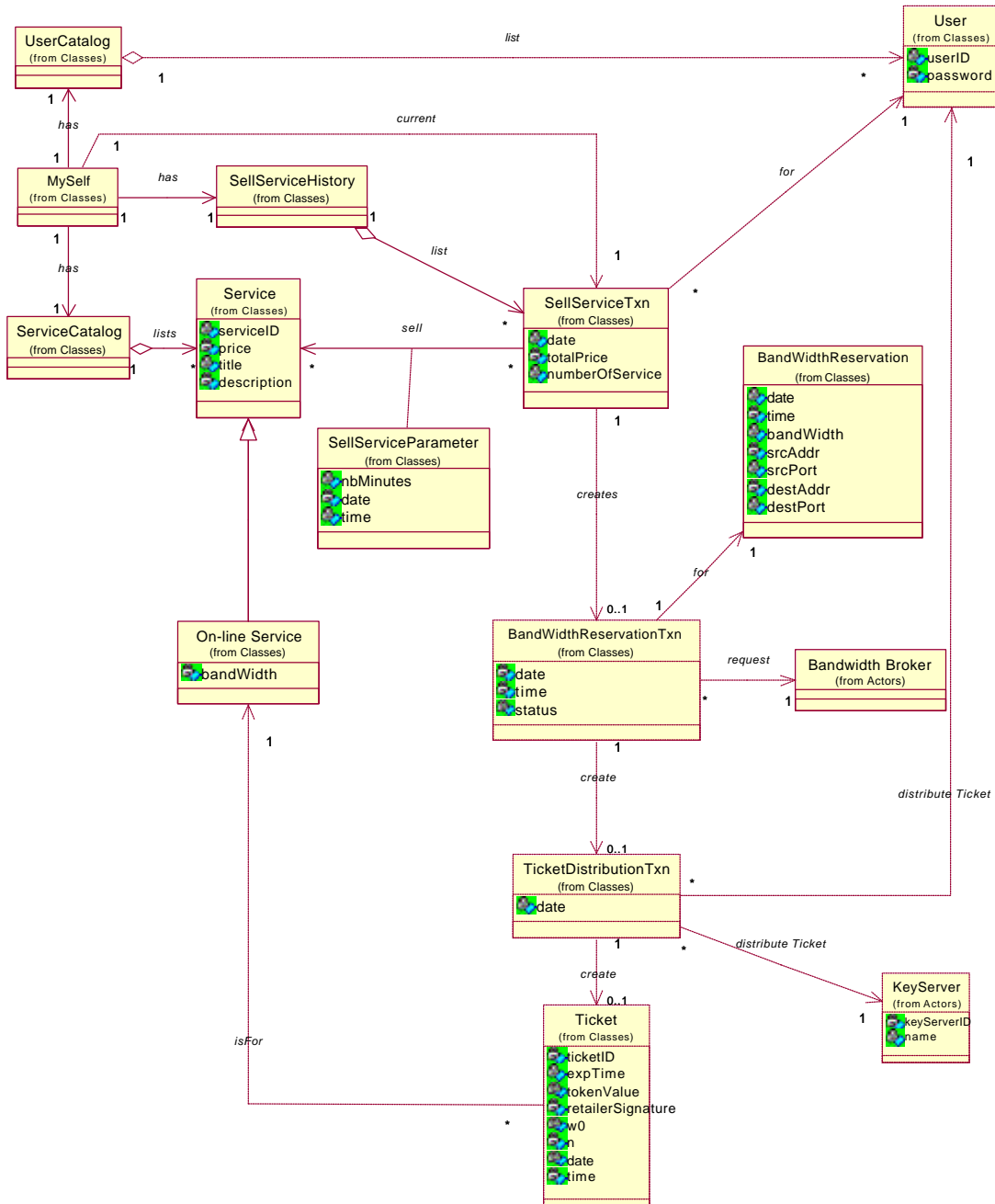

Glossary

SellServiceParameter

Concept representing the different way a Service can be bought, i.e. payment per views, payment per time and payment per copy

ServiceCatalog

- Concept representing all ServiceSpecs
- SellServiceHistory**
Concept representing all past Sell Service Transactions
- Service**
Concept representing any kind of Service
- MySelf**
- On-line Service**
Concept representing a Service in form of an Online Service
- Bandwidth Broker**
A BandWidth Broker BB is responsible for the bandwidth reservation
- BandWidthReservation**
Concept representing the bandwidth reserve for an on line service
- UserCatalog**
Concept representing all User concepts
- SellServiceTxn**
Concept representing information regarding the action of selling one or several Services
- Ticket**
Concept representing a ticket that is used to get an online Service
- KeyServer**
A Key Server works like a Digital Righth Manager. It is responsible for the digital keys distribution used for encrypting and decrypting online streams
- BandWidthReservationTxn**
Concept representing information regarding the action of reserving the bandWidth
- User**
Concept representing one User of the System, i.e. a Member
- TicketDistributionTxn**
Concept representing information regarding the action of distributing the Ticket

Conceptual Model : BSystem View-Point

**Conceptual Model Sell a service :
BandWidth Broker View-Point > Buy a Service > BandWidth Reseration**

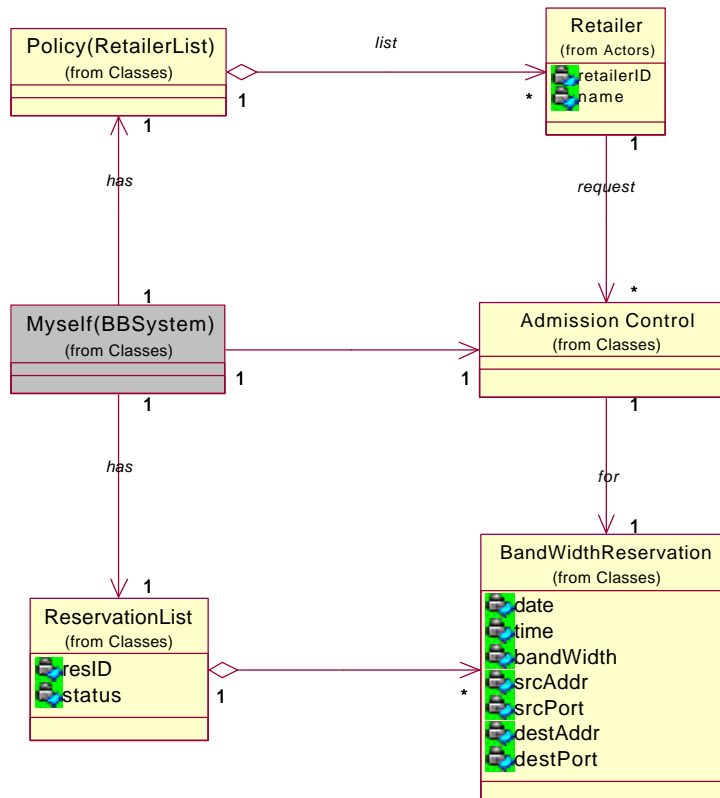

Glossary

Policy(RetailerList)

Concept representing all Retailer that has administrative permission to make reservation

ReservationList

Concept representing all BandWidth Reservation

Myself(BBSystem)

Retailer

A Retailer sells streams (provided by the Content Provider) to Customer

BandWidthReservation

Concept representing the bandwidth reserve for an on line service

Admission Control

Concept representing the action of setup Bandwidth Reservation

Conceptual Model : KeyServer View-Point

Conceptual Model :
KeyServer View-Point > Buy a Service > Get Ticket

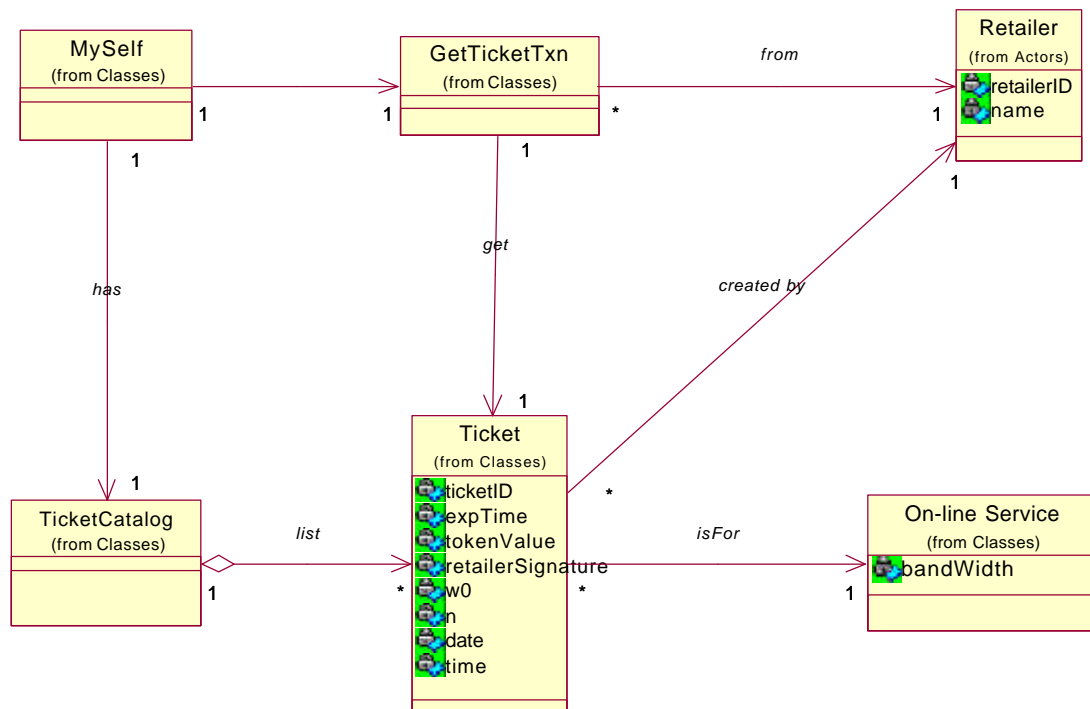

Glossary

Retailer

A Retailer sells streams (provided by the Content Provider) to Customer

On-line Service

Concept representing a Service in form of an Online Service

GetTicketTxn

Concept representing information regarding the action of getting Ticket that is stand for money

MySelf

Ticket

Concept representing a ticket that is used to get an online Service

TicketCatalog

Concept representing all current Ticket of KeyServer

Conceptual Model : Ticket

Conceptual Model for Ticket

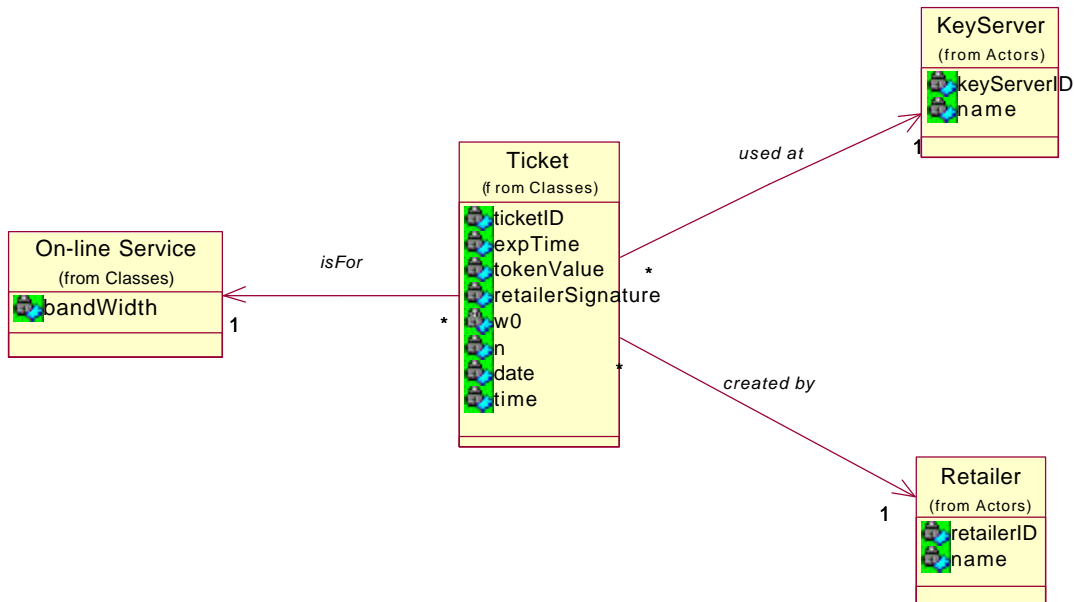

Glossary

KeyServer

A Key Server works like a Digital Right Manager. It is responsible for the digital keys distribution used for encrypting and decrypting online streams

Retailer

A Retailer sells streams (provided by the Content Provider) to Customer

Ticket

Concept representing a ticket that is used to get an online Service

On-line Service

Concept representing a Service in form of an Online Service

3.1.1. Get a Service

Activity Diagram : Get a Service in particular

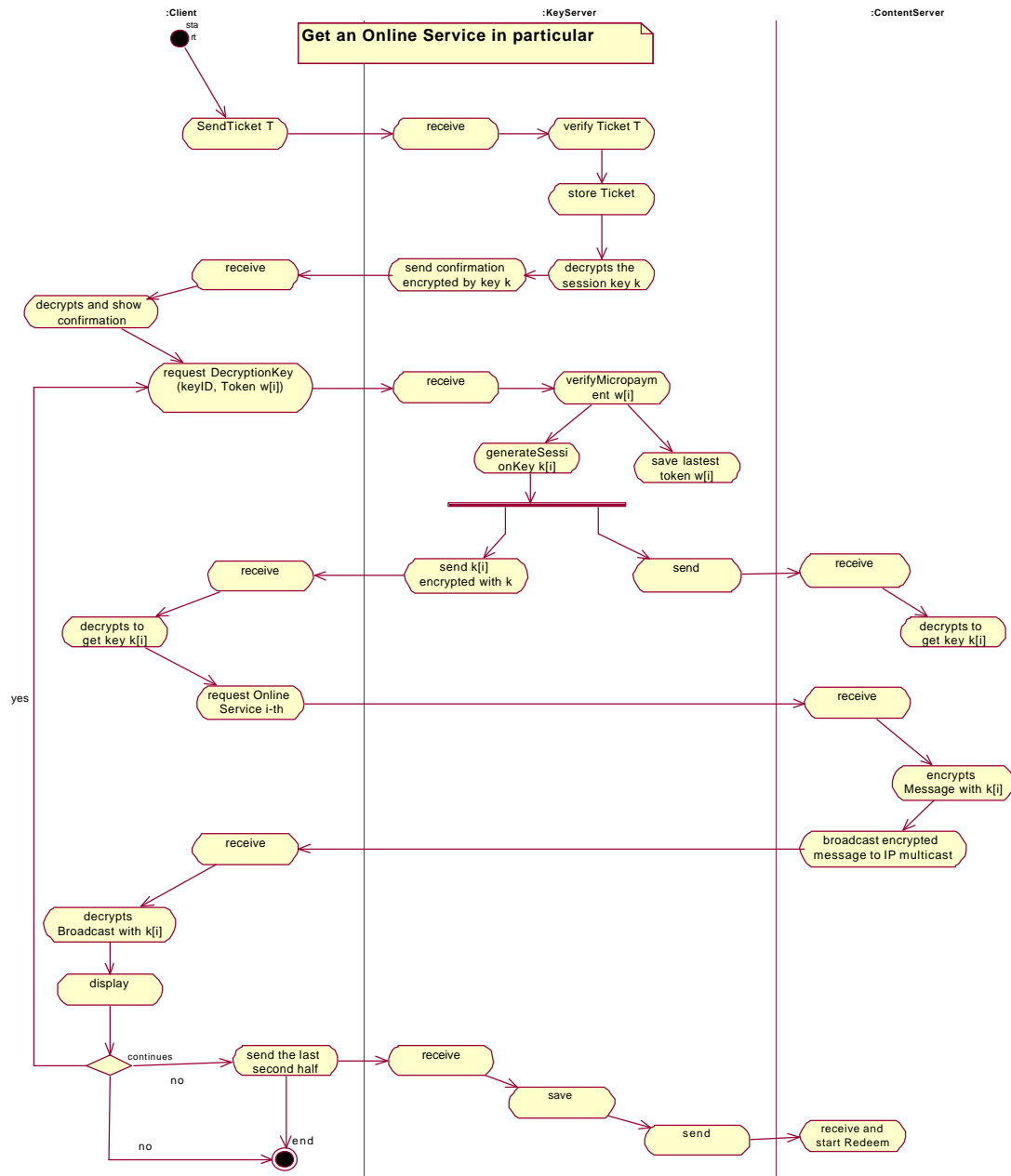

Pattern of Get a Service

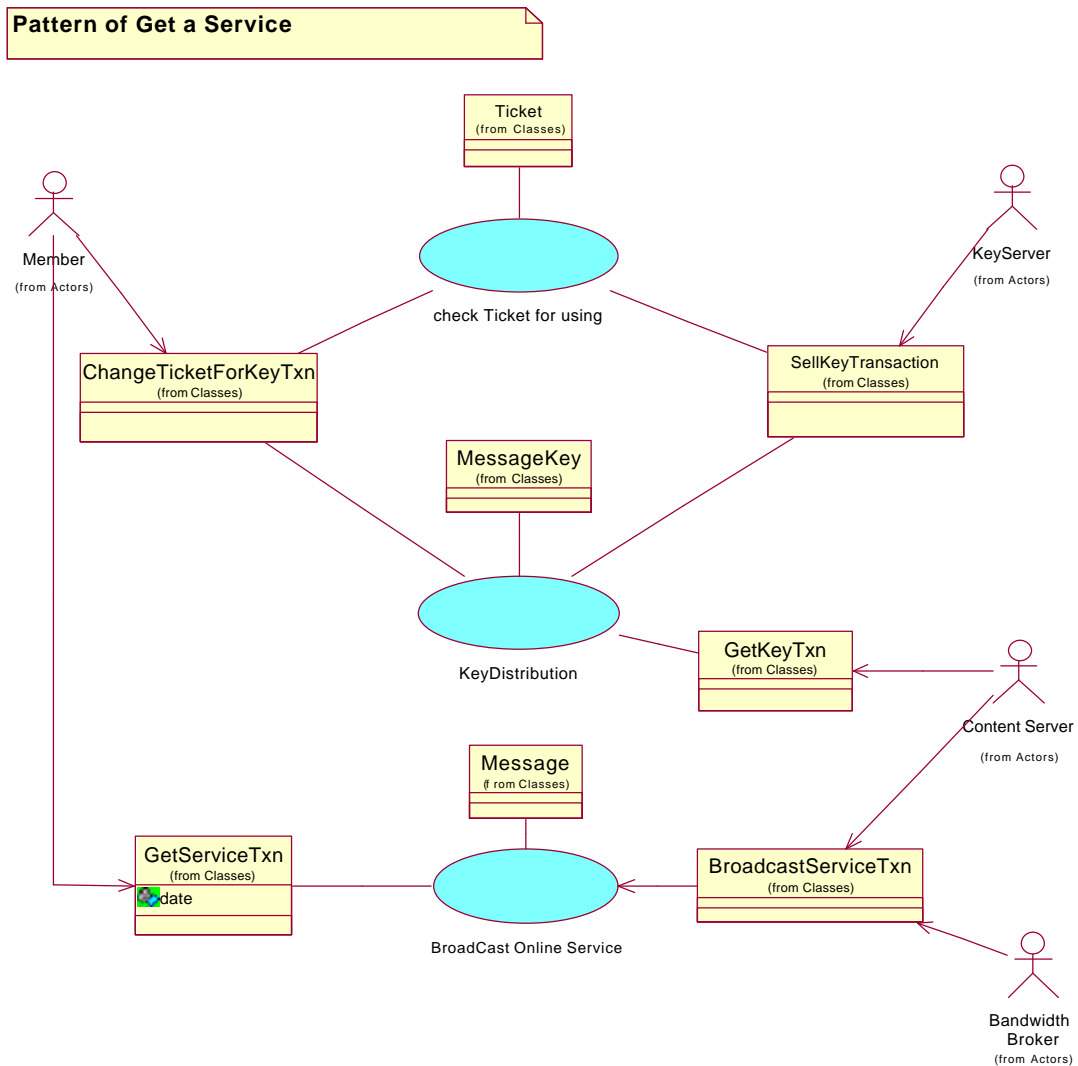

Glossary

Ticket

Concept representing a ticket that is used to get an online Service

MessageKey

Concept representing key to decrypt or encrypt a message that is a part of an Online Service

Message

Concept representing a message that is a part of an Online Service

ChangeTicketForKeyTxn

Concept representing information regarding the action of change Ticket for Key that is used to decrypt the online Service

Member

GetServiceTxn

Concept representing information regarding the action of getting a message that is a part of an Online Service

Content Server

A Content Server disseminates service to Customer by broadcasting encrypted message which is a part of a stream

GetKeyTxn

Concept representing information regarding the action of getting key that is used to encrypt message before broadcasting

Bandwidth Broker

A BandWidth Broker BB is responsible for the bandwidth reservation

BroadcastServiceTxn

Concept represent information regarding the action of encrypting and broadcasting a message of an Online Service

KeyServer

A Key Server works like a Digital Righth Manager. It is responsible for the digital keys distribution used for encrypting and decrypting online streams

SellKeyTransaction

Concept representing information regarding the action of selling key that is used to encrypt or decrypt a message of an online service

Conceptual Model : ClientSystem View-Point

Conceptual Model :Get a Service
ClientSystem View-Point > Get an Online Service

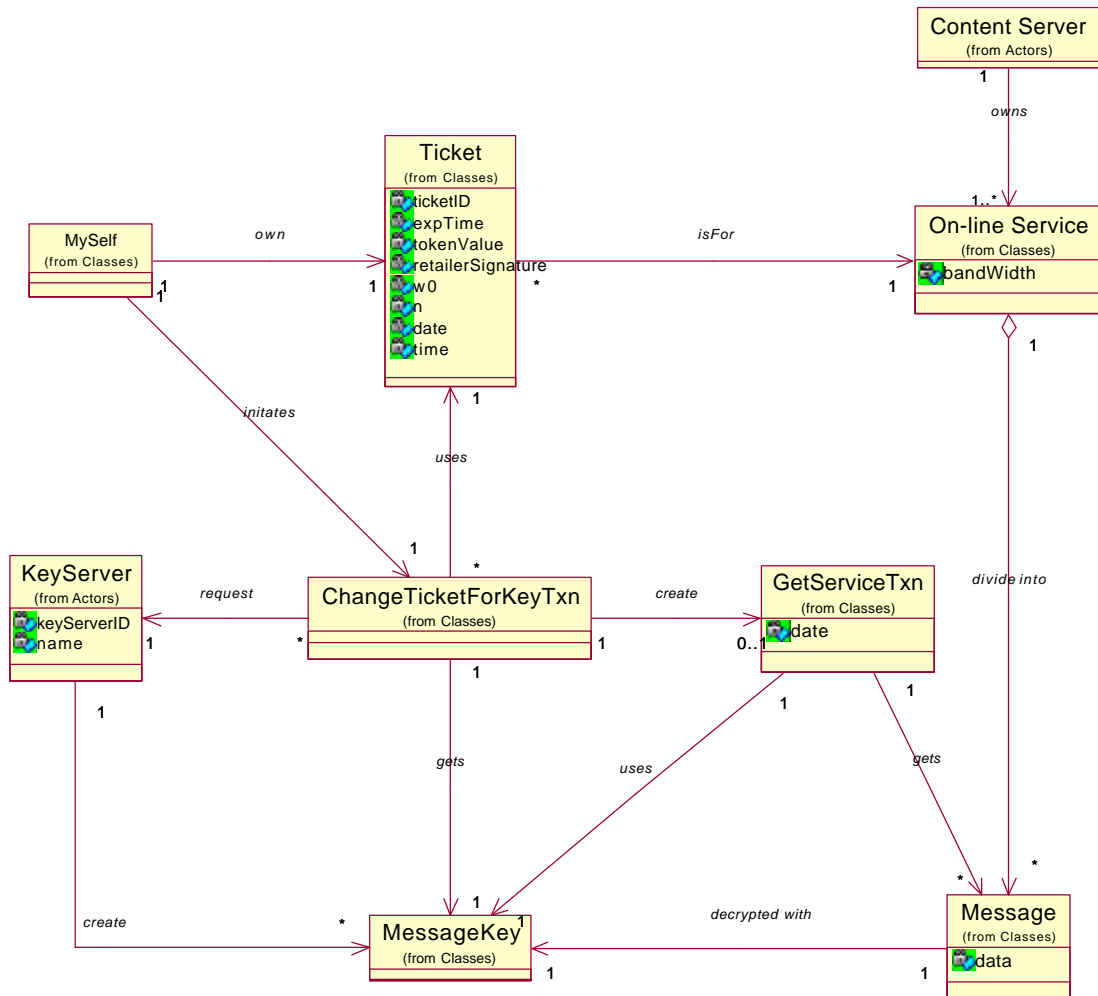

Glossary

Content Server

A Content Server disseminates service to Customer by broadcasting encrypted message which is a part of a stream

Message

Concept representing a message that is a part of an Online Service

On-line Service

Concept representing a Service in form of an Online Service

KeyServer

A Key Server works like a Digital Right Manager. It is responsible for the digital keys distribution used for encrypting and decrypting online streams

GetServiceTxn

Concept representing information regarding the action of getting a message that is a part of an Online Service

MessageKey

Concept representing key to decrypt or encrypt a message that is a part of an Online Service

Ticket

Concept representing a ticket that is used to get an online Service

ChangeTicketForKeyTxn

Concept representing information regarding the action of change Ticket for Key that is used to decrypt the online Service

MySelf

Conceptual Model : ContentSystem View-Point

Conceptual Model : BroadCast Online Service
Content View-Point > BroadCast Online Service

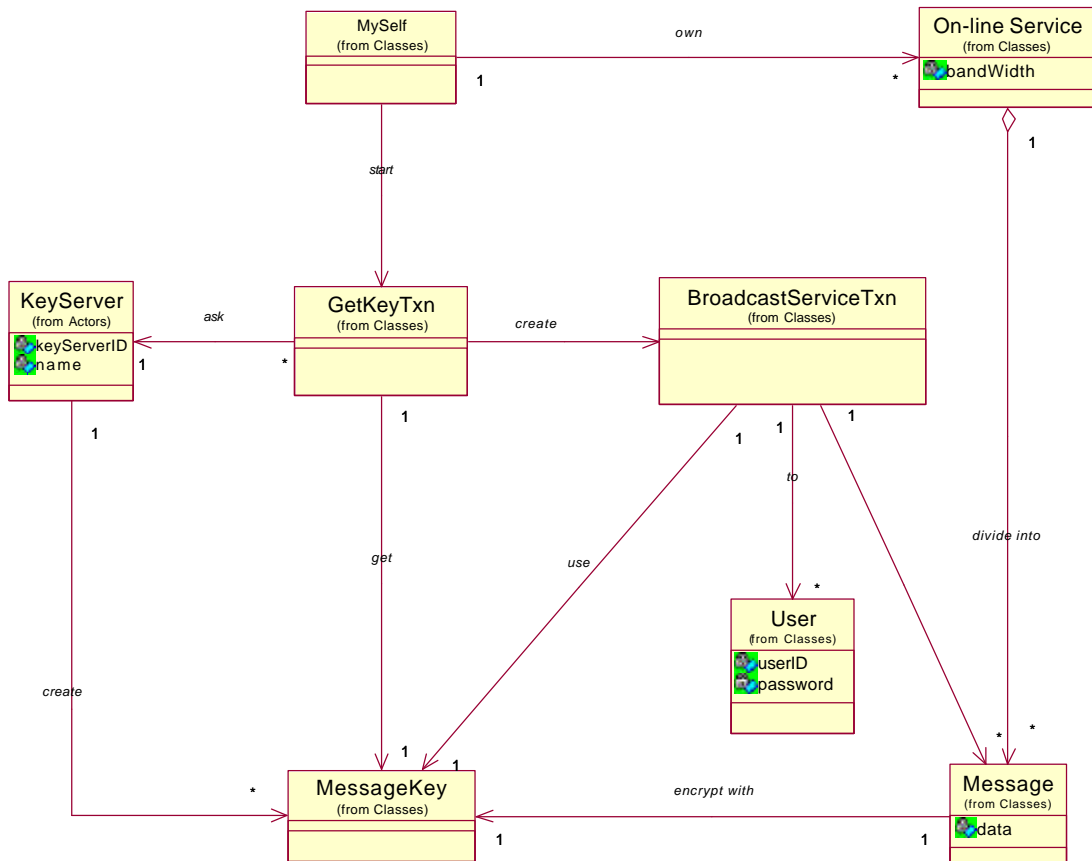

Glossary

MySelf

On-line Service

Concept representing a Service in form of an Online Service

KeyServer

A Key Server works like a Digital Right Manager. It is responsible for the digital keys distribution used for encrypting and decrypting online streams

User

Concept representing one User of the System, i.e. a Member

GetKeyTxn

Concept representing information regarding the action of getting key that is used to encrypt message before broadcasting

Message

Concept representing a message that is a part of an Online Service

MessageKey

Concept representing key to decrypt or encrypt a message that is a part of an Online Service

BroadcastServiceTxn

Concept represent information regarding the action of encrypting and broadcasting a message of an Online Service

Conceptual Model : KeyServer View-Point

Conceptual Model : Get a Service
KeyServer View-Point > Get Online Service > Sell Keys

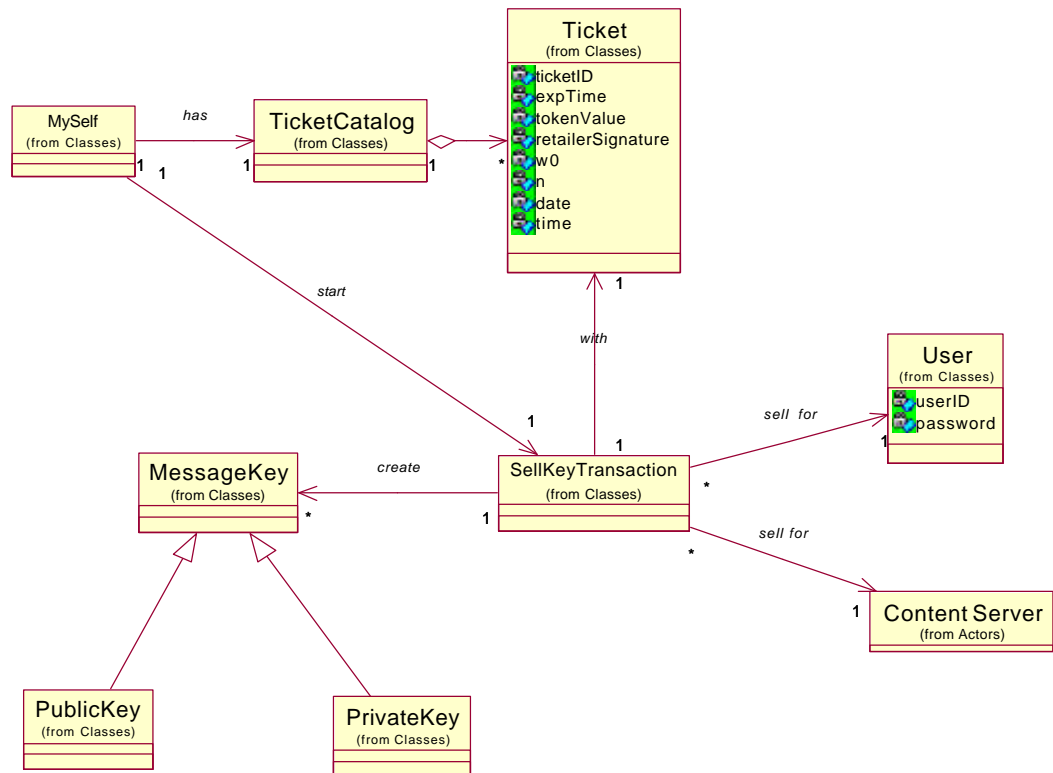

Glossary

PublicKey

Concept representing public key that is used to encrypt the message

PrivateKey

Concept representing public key that is used to encrypt the message

User

Concept representing one User of the System, i.e. a Member

MessageKey

Concept representing key to decrypt or encrypt a message that is a part of an Online Service

Content Server

A Content Server disseminates service to Customer by broadcasting encrypted message which is a part of a stream

Ticket

Concept representing a ticket that is used to get an online Service

TicketCatalog

Concept representing all current Ticket of KeyServer

SellKeyTransaction

Concept representing information regarding the action of selling key that is used to encrypt or decrypt a message of an online service

MySelf

Conceptual Model : BBSystem View-Point

Conceptual Model Get a Service : BBSystem View-Point

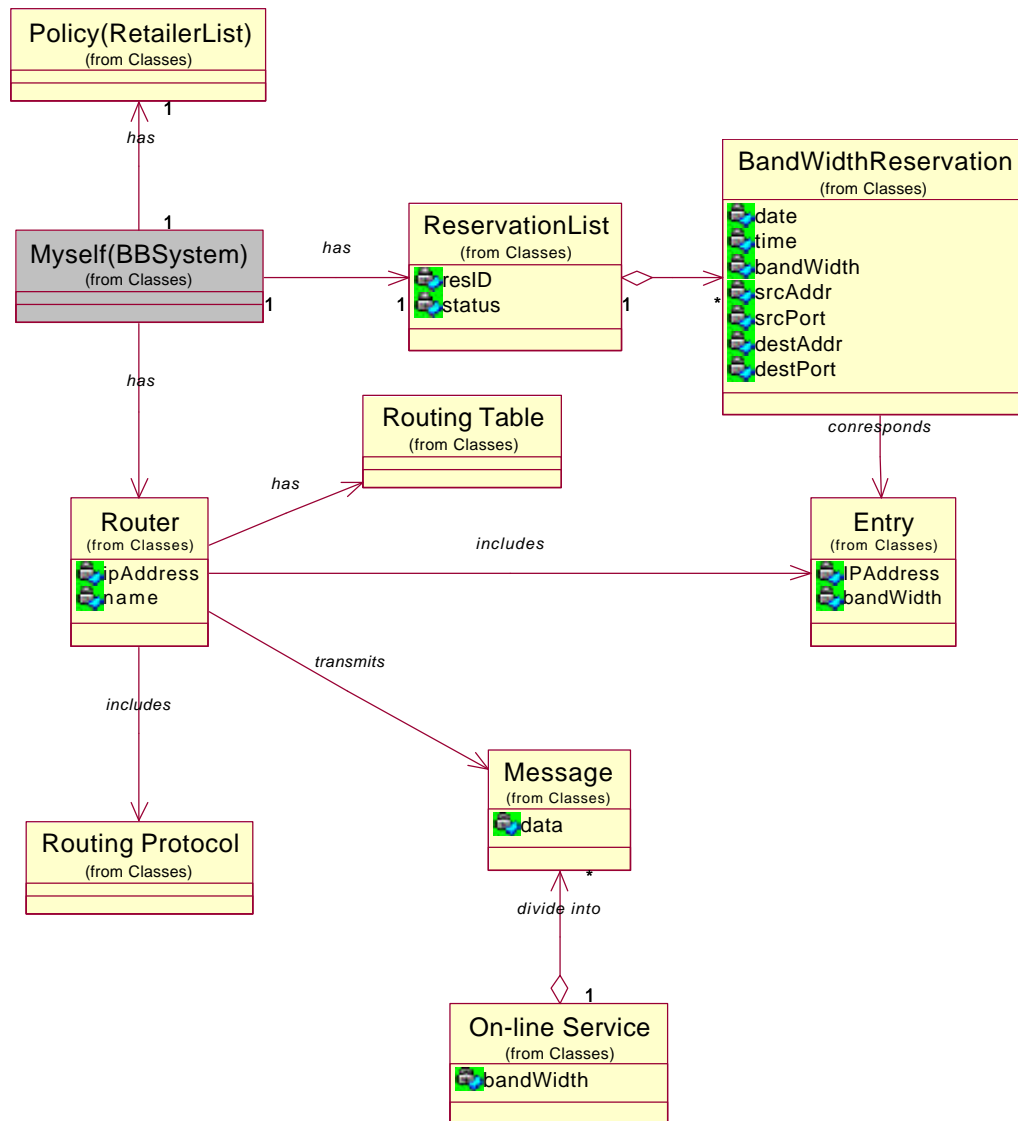

Glossary

BandWidthReservation

Concept representing the bandwidth reserve for an on line service

ReservationList

Concept representing all BandWidth Reservation

Policy(RetailerList)

Concept representing all Retailer that has administrative permission to make reservation

On-line Service

Concept representing a Service in form of an Online Service

Routing Protocol

Concept representing routing protocol using in a router

Entry

Myself(BBSystem)

Message

Concept representing a message that is a part of an Online Service

Routing Table

Router

3.1.2. Payment

Payment

Payment Collaboration

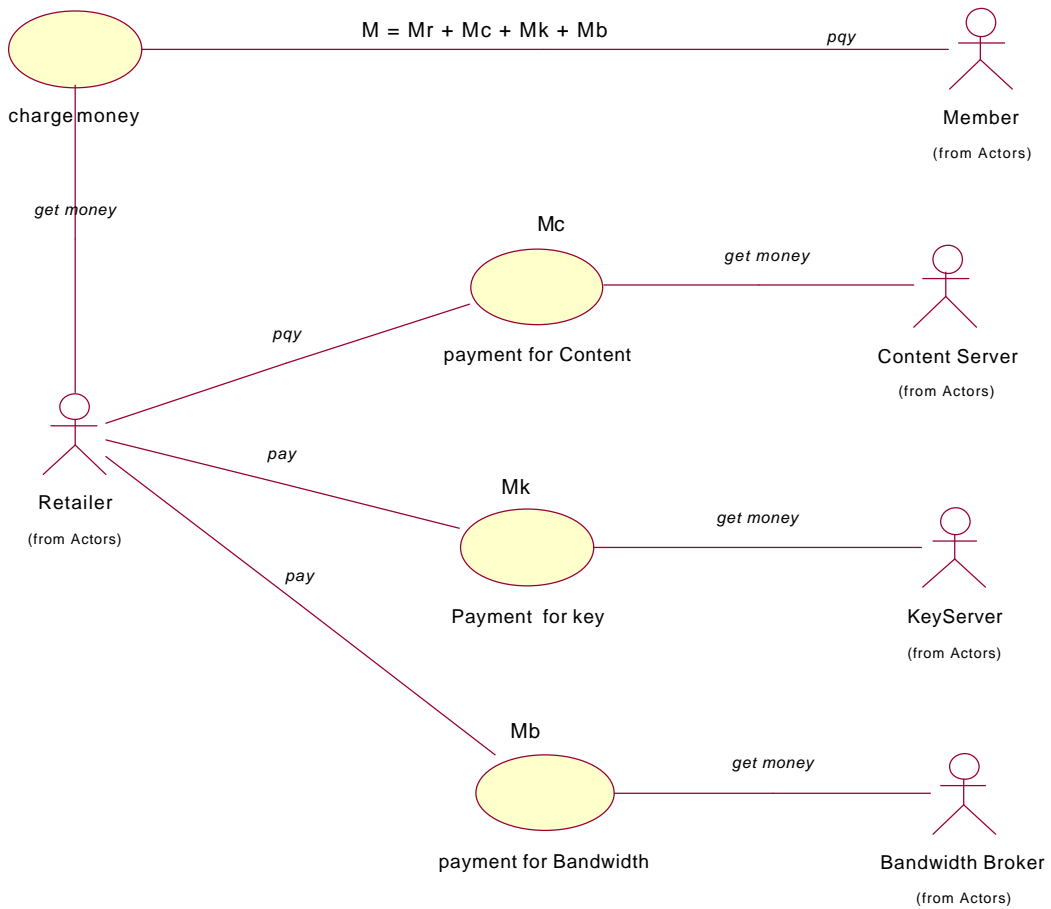

$M = Mr + Mc + Mk + Mb$
 Mr = Money for Retailer
 Mc = Money for Content Server
 Mk = Money for Key Server
 Mb = Money for Bandwidth Broker

Payment

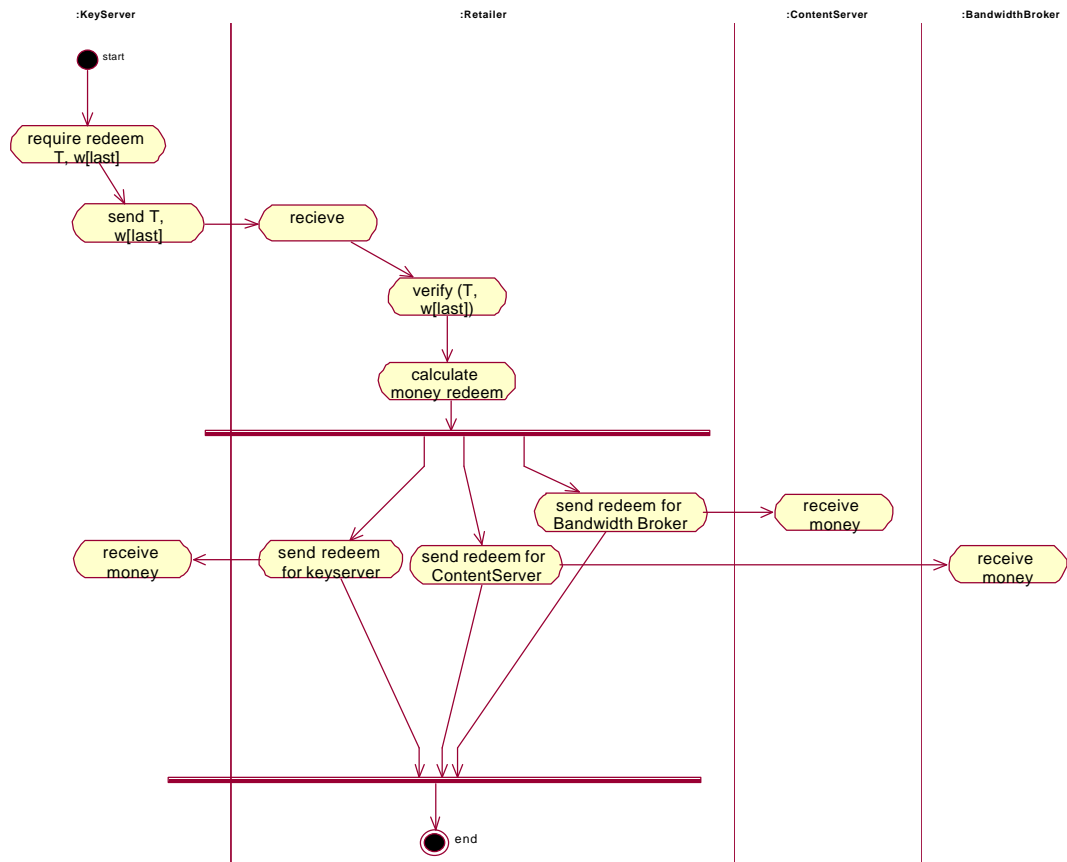

4.IT System Implementation

4.1. Sell and Get a Service

4.1.1. Sell a Service

Sequence Diagram : Choose a Service

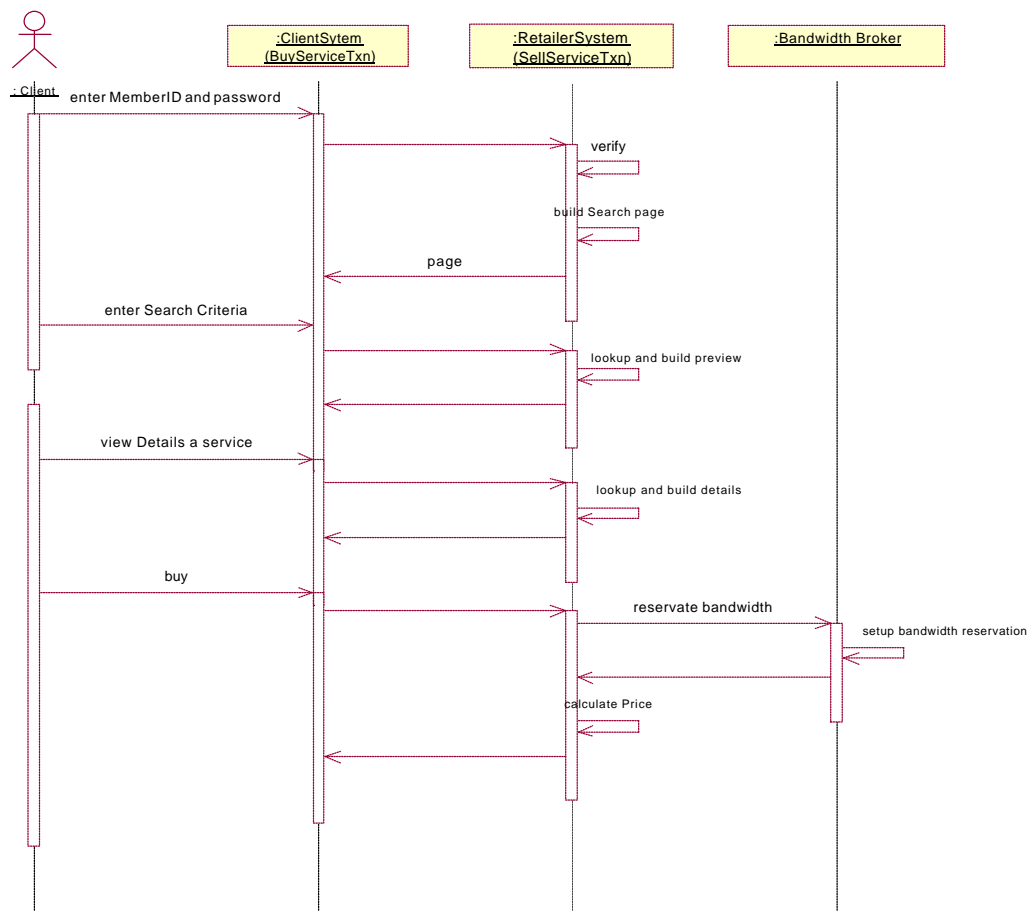

Sequence Diagram : Buy a Service

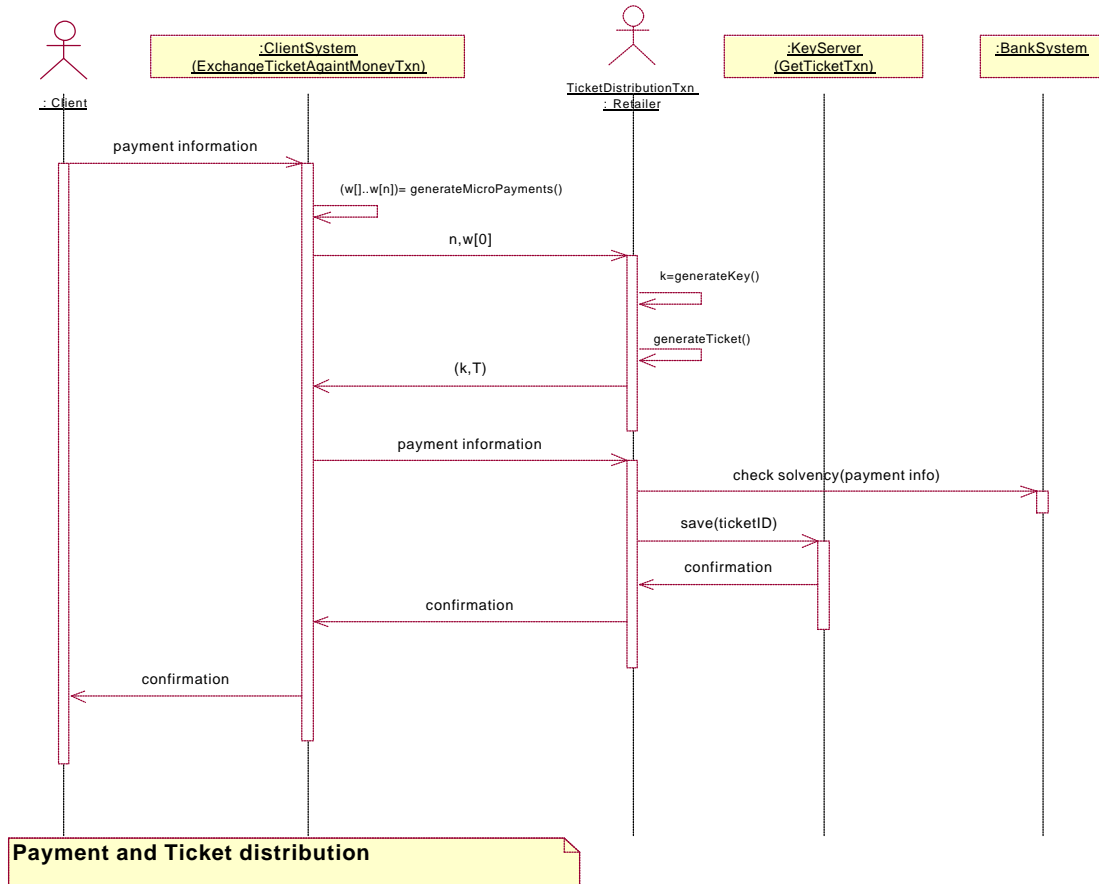

Logical Design Class Diagram : Client System View-Point

Logical Design Class Diagram : ClientSystem View-Point > Buy a Service

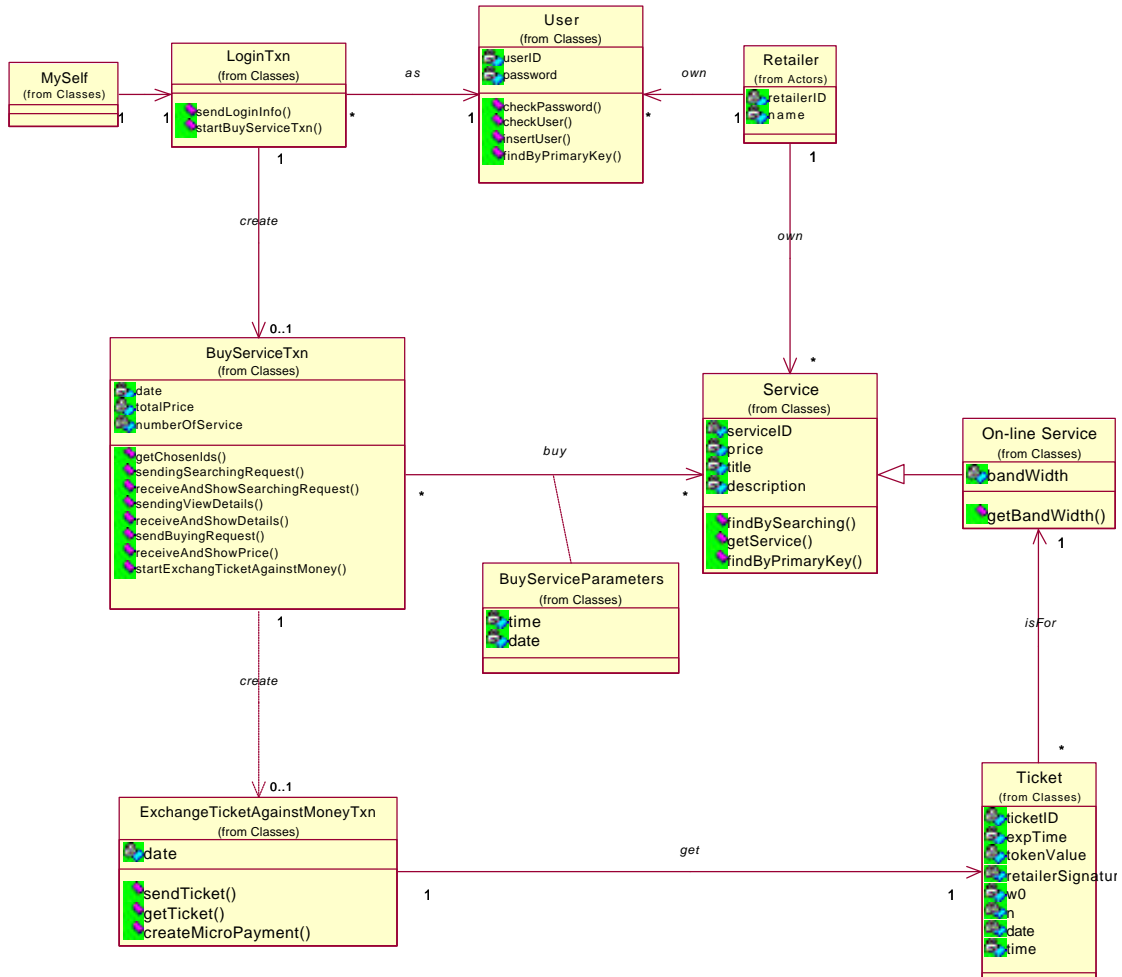

Glossary

BuyServiceParameters

Concept representing some information when buy a Service

On-line Service

Concept representing a Service in form of an Online Service

MySelf

User

Concept representing one User of the System, i.e. a Member

Retailer

A Retailer sells streams (provided by the Content Provider) to Customer

Ticket

Concept representing a ticket that is used to get an online Service

LoginTxn

Concept representing information regarding the action of a Customer login on the System

Service

Concept representing any kind of Service

ExchangeTicketAgainstMoneyTxn

Concept representing information regarding the action of buying Ticket for an online service

BuyServiceTxn

Concept representing information regarding the action of buying Services

Logical Design Class Diagram : RetailerSystem View-Point

Logical Design Class Diagram :
Retailer View-Point > Sell a Service

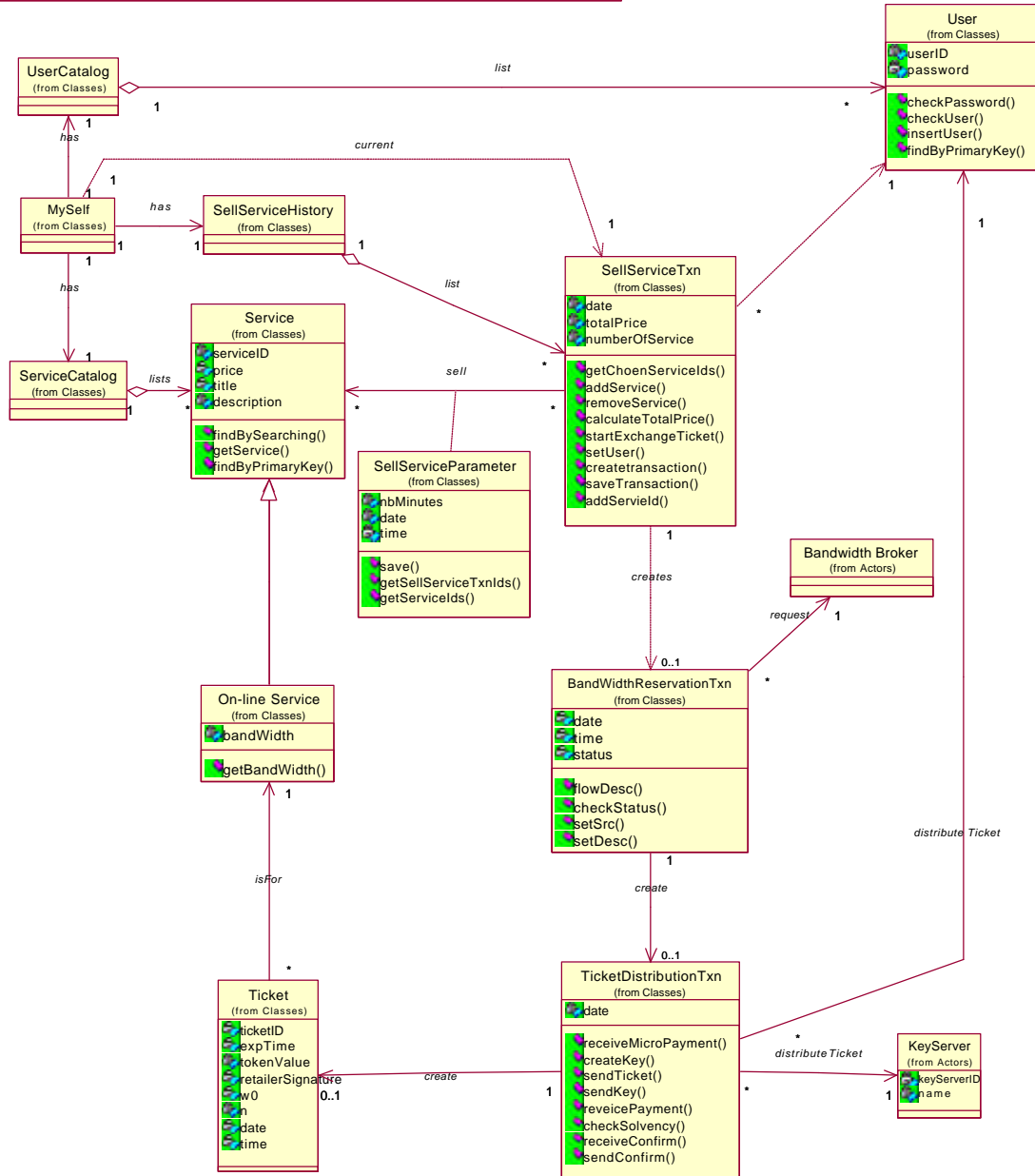

Glossary

SellServiceParameter

Concept representing the different way a Service can be bought, i.e. payment per views, payment per time and payment per copy

Ticket

Concept representing a ticket that is used to get an online Service

KeyServer

- A Key Server works like a Digital Righth Manager. It is responsible for the digital keys distribution used for encrypting and decrypting online streams
- On-line Service**
Concept representing a Service in form of an Online Service
- Bandwidth Broker**
A BandWidth Broker BB is responsible for the bandwidth reservation
- ServiceCatalog**
Concept representing all ServiceSpecs
- UserCatalog**
Concept representing all User concepts
- TicketDistributionTxn**
Concept representing information regarding the action of distributing the Ticket
- SellServiceHistory**
Concept representing all past Sell Service Transactions
- Service**
Concept representing any kind of Service
- BandWidthReservationTxn**
Concept representing information regarding the action of reserving the bandWidth
- MySelf**
- User**
Concept representing one User of the System, i.e. a Member
- SellServiceTxn**
Concept representing information regarding the action of selling one or several Services

Logical Design Class Diagram : BBSystem View-Point

Logical Design Class Diagram : BBSystem View-Point > Buy a Service > Bandwidth Reservation

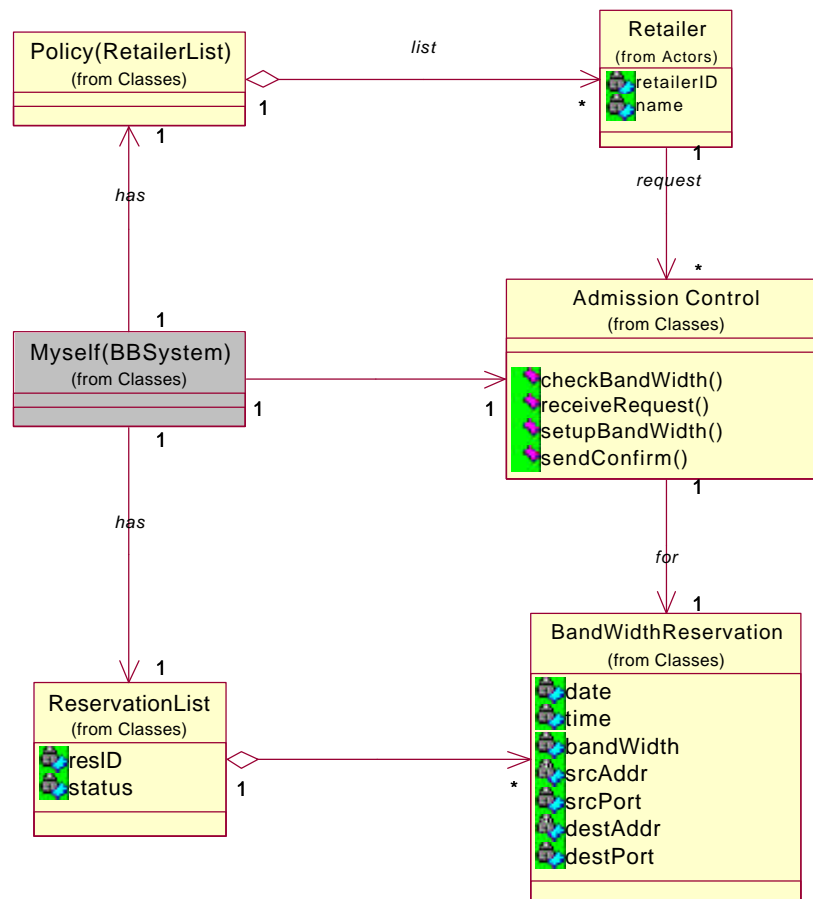

Glossary

Policy(RetailerList)

Concept representing all Retailer that has administrative permission to make reservation

ReservationList

Concept representing all BandWidth Reservation

Myself(BBSystem)

Retailer

A Retailer sells streams (provided by the Content Provider) to Customer

BandWidthReservation

Concept representing the bandwidth reserve for an on line service

Admission Control

Concept representing the action of setup Bandwidth Reservation

Logical Design Class Diagram : KeyServer View-Point

**Logical Design Class Diagram :
KeyServer View-Point > Buy a Service > Get Ticket**

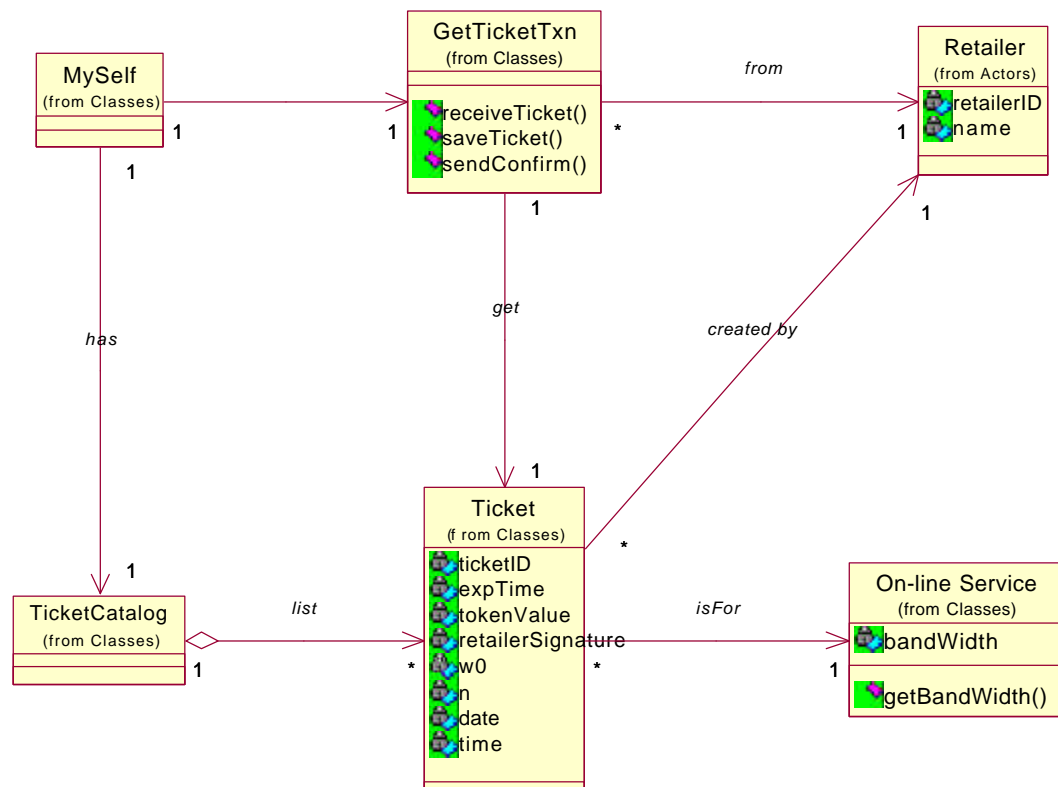

Glossary

Retailer

A Retailer sells streams (provided by the Content Provider) to Customer

On-line Service

Concept representing a Service in form of an Online Service

GetTicketTxn

Concept representing information regarding the action of getting Ticket that is stand for money

MySelf

Ticket

Concept representing a ticket that is used to get an online Service

TicketCatalog

Concept representing all current Ticket of KeyServer

Interfaces in Get a Service

Interfaces in Sell Service

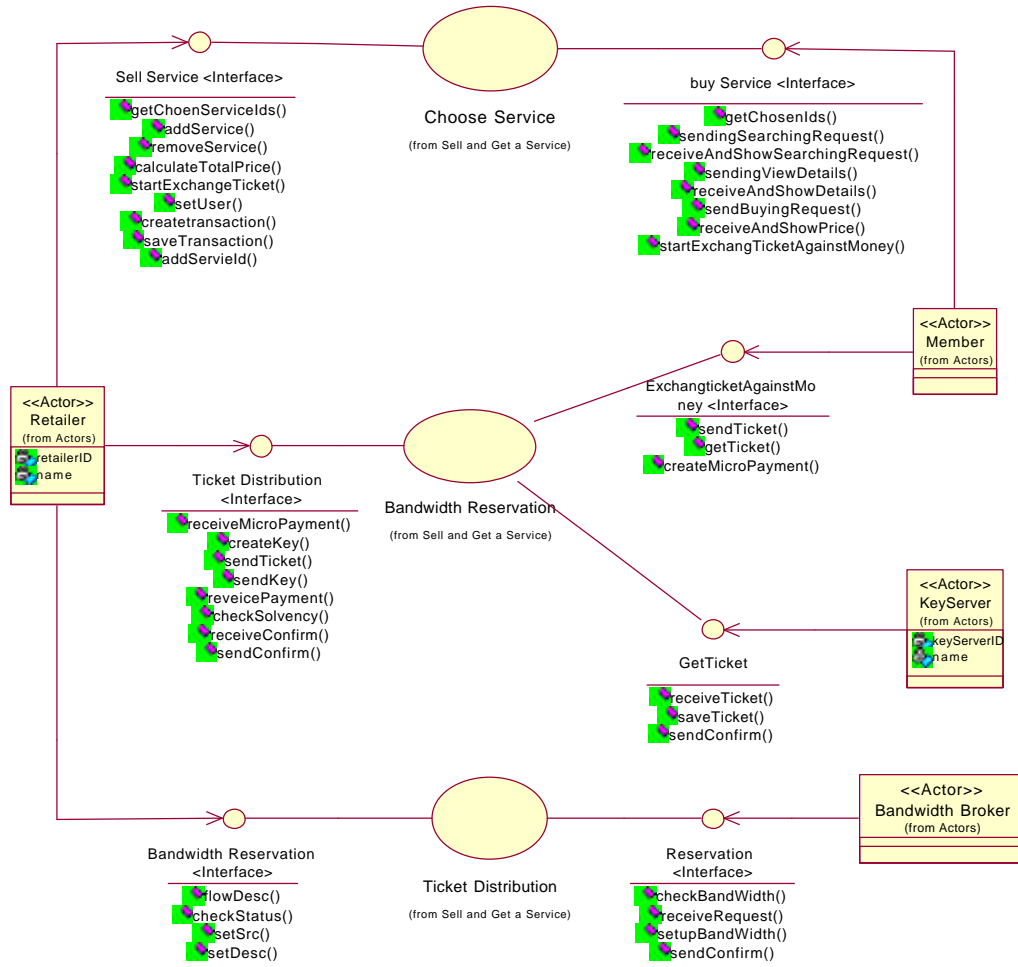

4.1.2. Get a Service

Sequence Diagram : Get a Service

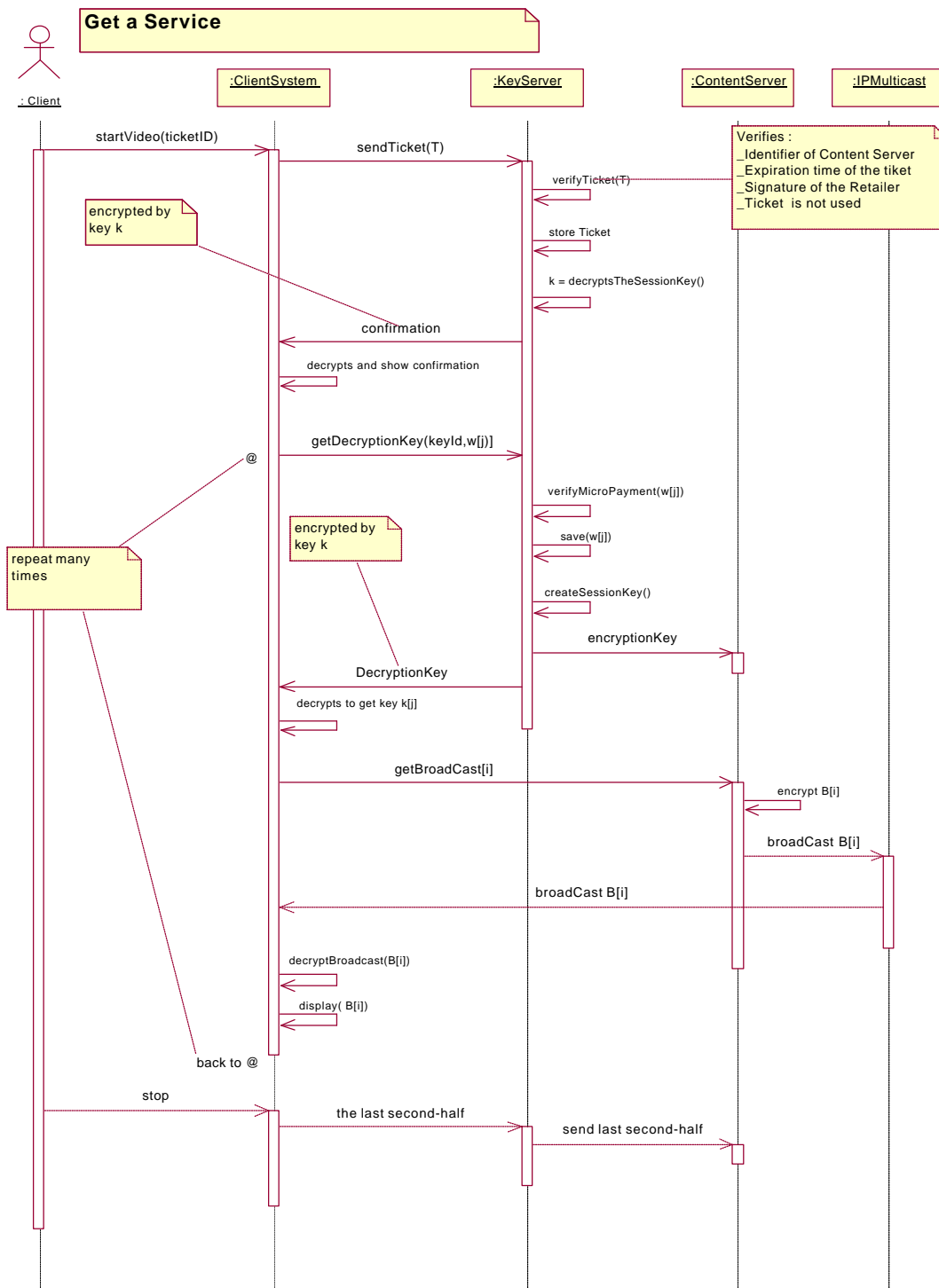

Logical Design Class Diagram : ClientSystem View-Point

Logical Design Class Diagram : Client View-Point > Get an Online-Service

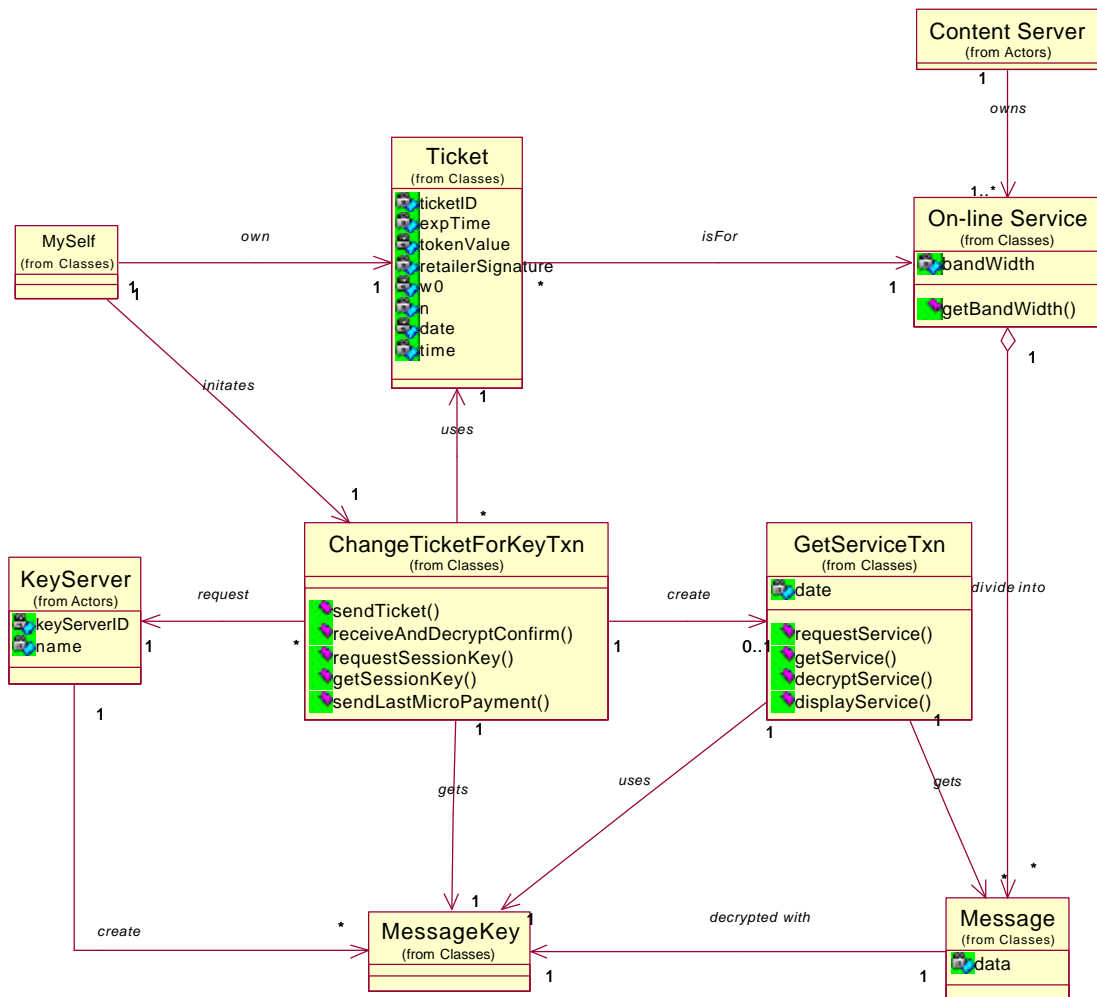

Glossary

Content Server

A Content Server disseminates service to Customer by broadcasting encrypted message which is a part of a stream

Message

Concept representing a message that is a part of an Online Service

On-line Service

Concept representing a Service in form of an Online Service

KeyServer

A Key Server works like a Digital Right Manager. It is responsible for the digital keys distribution used for encrypting and decrypting online streams

GetServiceTxn

Concept representing information regarding the action of getting a message that is a part of an Online Service

MessageKey

Concept representing key to decrypt or encrypt a message that is a part of an Online Service

Ticket

Concept representing a ticket that is used to get an online Service

ChangeTicketForKeyTxn

Concept representing information regarding the action of change Ticket for Key that is used to decrypt the online Service

MySelf

Logical Design Class Diagram : ContentServer View-Point

Logical Design Class Diagram : Get a Service
ContentServer View-Point > BroadCast Online Service

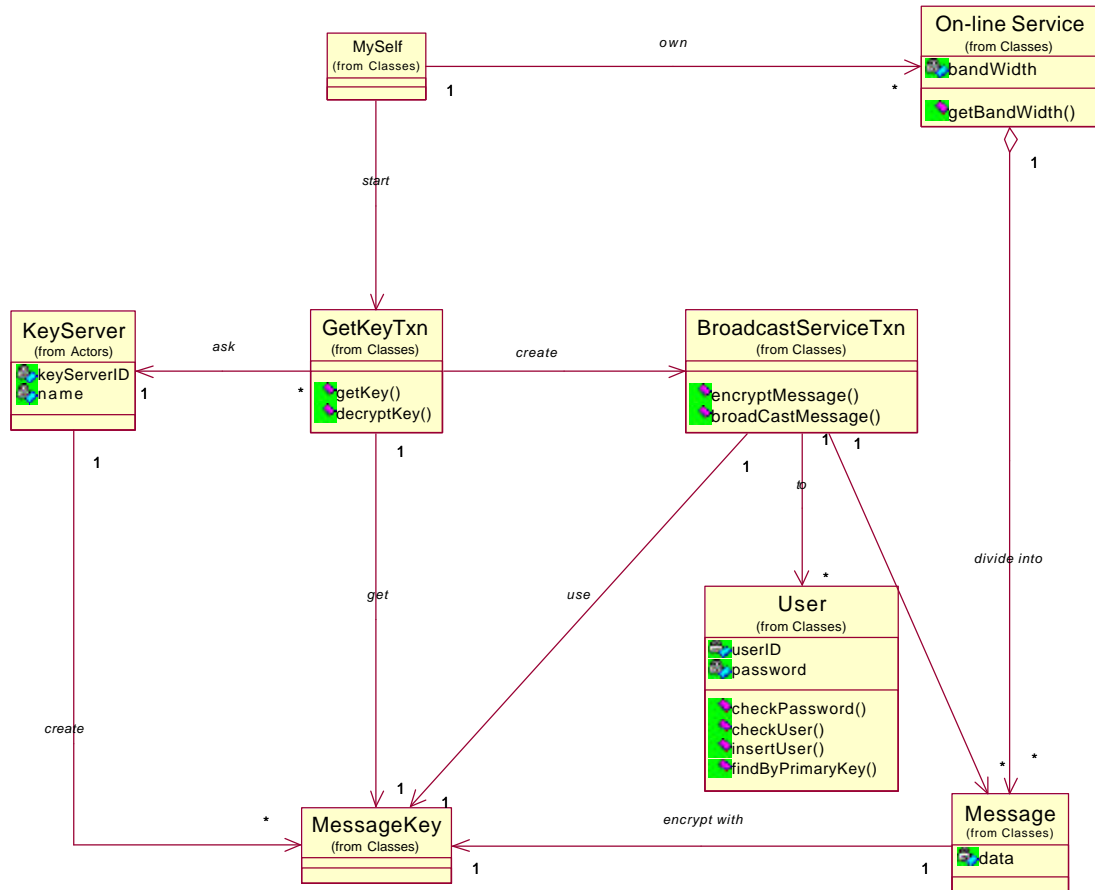

Glossary

MySelf

On-line Service

Concept representing a Service in form of an Online Service

KeyServer

A Key Server works like a Digital Righth Manager. It is responsible for the digital keys distribution used for encrypting and decrypting online streams

User

Concept representing one User of the System, i.e. a Member

GetKeyTxn

Concept representing information regarding the action of getting key that is used to encrypt message before broadcasting

Message

Concept representing a message that is a part of an Online Service

MessageKey

Concept representing key to decrypt or encrypt a message that is a part of an Online Service

BroadcastServiceTxn

Concept represent information regarding the action of encrypting and broadcasting a message of an Online Service

Logical Design Class Diagram : KeyServer View-Point

Logical Design Class Diagram : Sell Keys
KeyServer View-Point > Get Online Service > Sell Keys

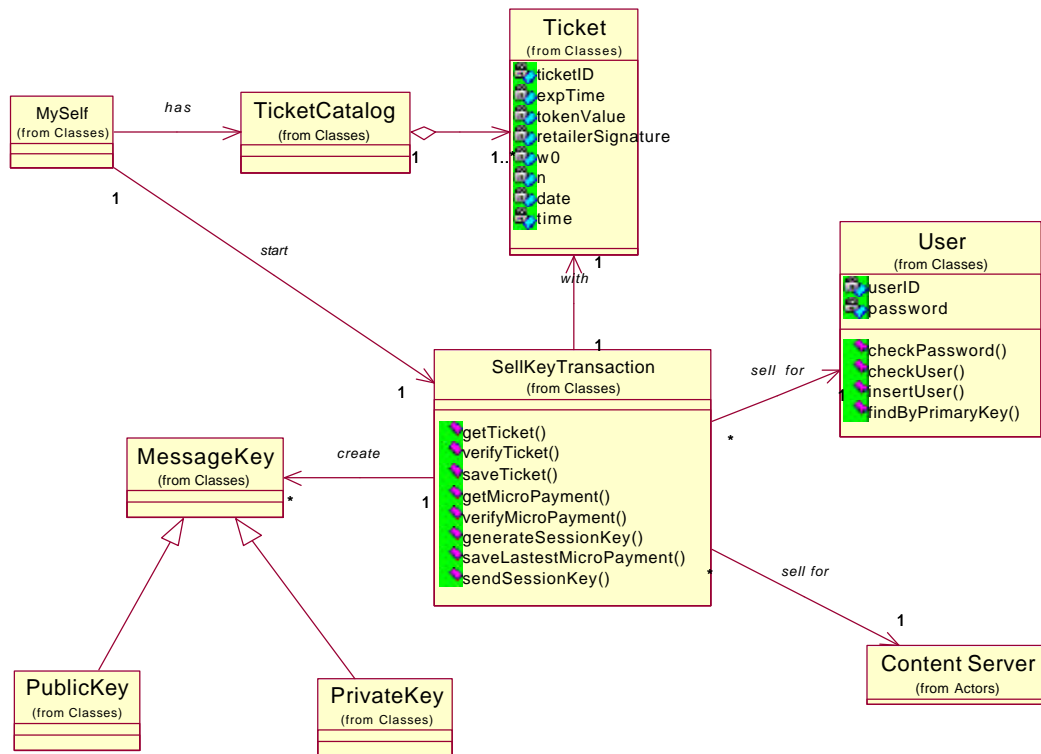

Glossary

PublicKey

Concept representing public key that is used to encrypt the message

PrivateKey

Concept representing public key that is used to encrypt the message

User

Concept representing one User of the System, i.e. a Member

MessageKey

Concept representing key to decrypt or encrypt a message that is a part of an Online Service

Content Server

A Content Server disseminates service to Customer by broadcasting encrypted message which is a part of a stream

Ticket

Concept representing a ticket that is used to get an online Service

TicketCatalog

Concept representing all current Ticket of KeyServer

SellKeyTransaction

Concept representing information regarding the action of selling key that is used to encrypt or decrypt a message of an online service

MySelf

Interfaces in Get a Service

Interfaces in Get a Service

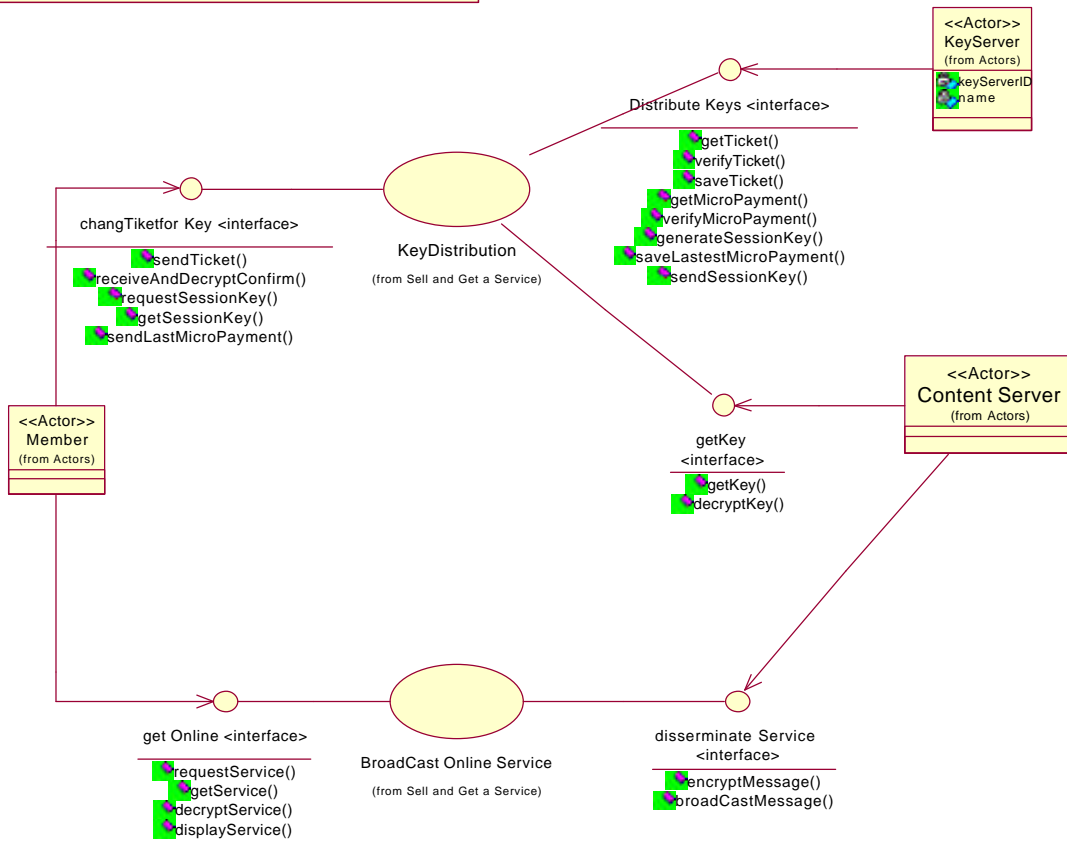

4.1.3. Redeem

Redeem

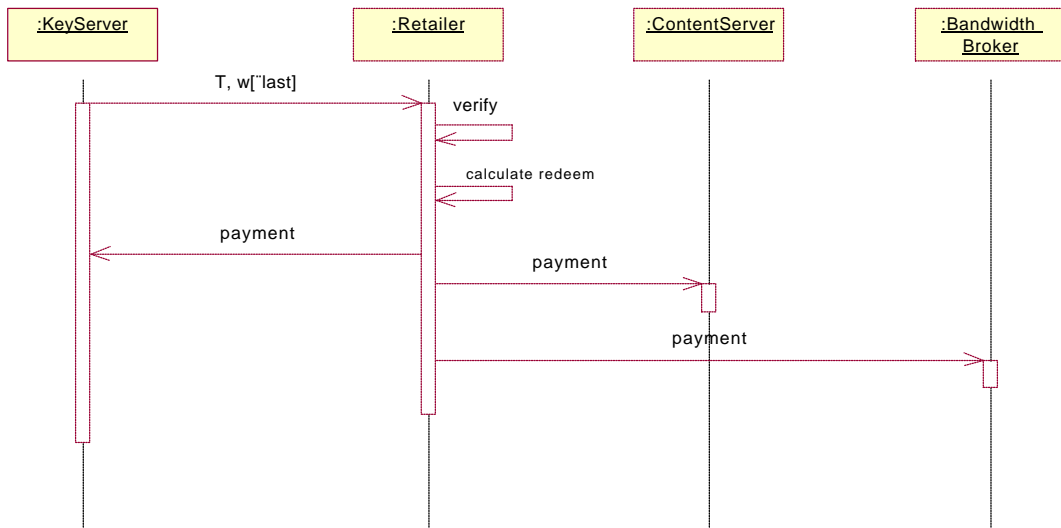

Sequence Diagram : Redeem process