

HIGH ORDER BALANCED MULTIWAVELETS

Jérôme Lebrun and Martin Vetterli

Dept. of Electrical Engineering
 Swiss Federal Institute of Technology, Lausanne
 {lebrun,vetterli}@de.epfl.ch

ABSTRACT

In this paper, we study the issue of regularity for multiwavelets. We generalize here the concept of balancing for higher degree discrete-time polynomial signals and link it to a very natural factorization of the lowpass refinement mask that is the counterpart of the well-known zeros at π condition for wavelets. This enables us to clarify the subtle relations between approximation power, smoothness and balancing order. Using these new results, we are also able to construct a family of orthogonal multiwavelets with symmetries and compact support that is indexed by the order of balancing. More details (filters coefficients, drawings of the whole family, frequency responses,...) can be obtained on the [web] at <http://lcavwww.epfl.ch/~lebrun>

1. INTRODUCTION

In the usual framework of wavelets, the two concepts of reproduction of continuous-time polynomials (approximation theory issue) and preservation/cancellation of discrete-time polynomial signals (subband coding and compression issue) are highly correlated since they have been proved to be equivalent to the same condition on the number of zeros at π in the factorization of the lowpass filter. The situation is different for multiwavelets. In [7, 8], interested in the subband coding issue in general and the problem of processing one dimensional signals with multiwavelets in particular, we introduced the concept of balanced multiwavelets that has since inspired many other papers [6, 11, 12]. The aim of this concept was to avoid the artificial step of prefiltering in multiwavelet based systems. Here, we will prove that the notion of balancing order is in fact central to the whole issue of regularity for multiwavelets.

2. MULTIWAVELETS

Generalizing the wavelet case, one can allow a multiresolution analysis $\{V_n\}_{n \in \mathbb{Z}}$ of $L^2(\mathbb{R})$ to be generated by a finite number of scaling functions $\phi_0(t), \phi_1(t), \dots, \phi_{r-1}(t)$ and their integer translates. Then, the multiscaling function $\phi(t) := [\phi_0(t), \dots, \phi_{r-1}(t)]^T$ verifies a 2-scale equation

$$\phi(t) = \sum_k M[k] \phi(2t - k) \quad (1)$$

This work was supported by the Swiss National Science Foundation.

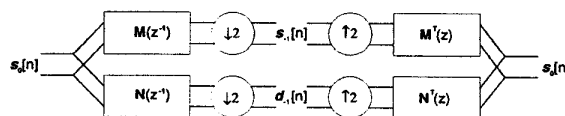
Figure 1: Orthogonal multifilter bank for $r = 2$.

where now $\{M[k]\}_k$ is a sequence of $r \times r$ matrices of real coefficients. The multiresolution analysis structure gives $V_1 = V_0 \oplus W_0$ where W_0 is the orthogonal complement of V_0 in V_1 . We can construct an orthonormal basis of W_0 generated by $\psi_0(t), \psi_1(t), \dots, \psi_{r-1}(t)$ and their integer translates with $\psi(t) := [\psi_0(t), \dots, \psi_{r-1}(t)]^T$ derived by

$$\psi(t) := \sum_k N[k] \phi(2t - k) \quad (2)$$

where $\{N[k]\}_k$ is a sequence of $r \times r$ matrices of real coefficients obtained by completion of $\{M[k]\}_k$. Introducing the refinement masks $M(z) := \frac{1}{2} \sum_n M[n] z^{-n}$ and $N(z) := \frac{1}{2} \sum_n N[n] z^{-n}$, the equations (1) and (2) translate in Fourier domain into

$$\Phi(2\omega) = M(e^{j\omega}) \Phi(\omega) \quad \text{and} \quad \Psi(2\omega) = N(e^{j\omega}) \Phi(\omega) \quad (3)$$

We can then derive the behavior of the multiscaling function by iterating the first product above. If this iterated matrix product converges, we get in the limit

$$\Phi(\omega) = M_\infty(\omega) \Phi(0) = \prod_{i=1}^{\infty} M(e^{j\frac{\omega}{2^i}}) \Phi(0) \quad (4)$$

For simplicity and without loss of generality, we will now on concentrate on the case $r = 2$. Furthermore, we will assume that the sequences $\{M[k]\}_k$ and $\{N[k]\}_k$ are finite and thus that $\phi(t)$ and $\psi(t)$ have compact support. We then recall some result obtained in [1] about the convergence of the iterated matrix product $M_\infty(\omega)$. For $M(z)$ satisfying a matrix Smith-Barnwell orthogonality condition

$$M(z) M^T(z^{-1}) + M(-z) M^T(-z^{-1}) = I \quad (5)$$

a necessary condition for uniform convergence of the iterated product to a scaling matrix $M_\infty(\omega)$ such that $M_\infty(0)$ is non-zero and bounded is either

- (i) $M(1) = I$, $M(-1) = 0$ (note that $M_\infty(\omega)$ has rank 2)
- (ii) $M(1)$ has eigenvalue $\lambda_0(1) = 1$ and $|\lambda_1(1)| < 1$, $M(-1)$ has rank 1 and satisfies $\mathbf{r}_0 M(-1) = 0$ where \mathbf{r}_0 is a left

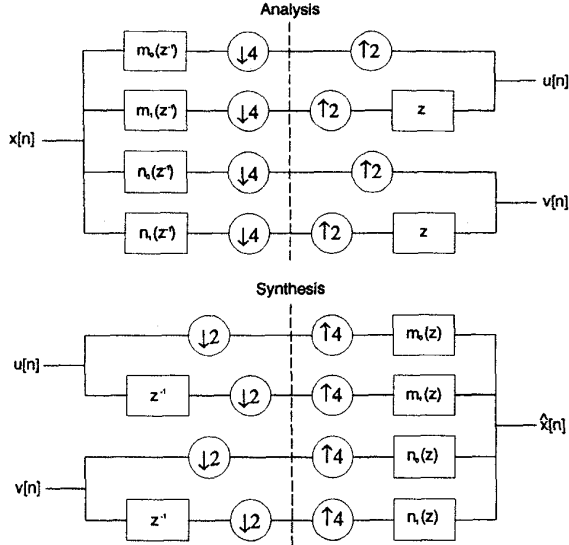

Figure 2: Multifilter bank seen as a time-varying filter bank.

eigenvector of $M(1)$ for the eigenvalue 1 (note that $M_\infty(\omega)$ has then rank 1).

Now, assuming (5) and (i) or (ii), the scaling functions and their integer translates form an orthonormal basis of V_0 . Thus, for $s(t) \in V_0$, we have

$$s(t) = \sum_n s_0^T[n] \phi(t - n) \quad (6)$$

then from $V_0 = V_{-1} \oplus W_{-1}$, we get

$$s(t) = \sum_n s_{-1}^T[n] \phi\left(\frac{t}{2} - n\right) + d_{-1}^T[n] \psi\left(\frac{t}{2} - n\right) \quad (7)$$

and we have the well known relations between the coefficients at the analysis step

$$s_{-1}[n] = \sum_k M[k - 2n] s_0[k] \quad (8)$$

$$d_{-1}[n] = \sum_k N[k - 2n] s_0[k] \quad (9)$$

and for the synthesis, we get

$$s_0[n] = \sum_k M^T[n - 2k] s_{-1}[k] + N^T[n - 2k] d_{-1}[k] \quad (10)$$

These relations enable us to construct a multi-input multi-output filter bank (abbr. multifilter bank) as seen in Fig. 1. In case of a one-dimensional signal, it then requires vectorization of this input signal to produce an input signal which is 2-dimensional. A simple way to do that is to split a one-dimensional signal into its polyphase components. Introducing

$$\begin{bmatrix} m_0(z) \\ m_1(z) \end{bmatrix} := M(z^2) \begin{bmatrix} 1 \\ z^{-1} \end{bmatrix} \quad (11)$$

and in the same way $n_0(z)$ and $n_1(z)$, the system can then be seen as a 4 channel time-varying filter bank (Fig. 2).

3. HIGH ORDER BALANCING

In [7, 8], we showed that if the components $m_0(z)$ and $m_1(z)$ of the lowpass branch have different spectral behavior, e.g. lowpass behavior for one, highpass for the other, it then leads to unbalanced channels that mix the coarse resolution and details coefficients and create strong oscillations. One expect then some class of smooth signals to be preserved by the lowpass branch and cancelled by the highpass.

3.1. Balancing

We define the band-Toeplitz matrix corresponding to the lowpass analysis

$$L := \begin{bmatrix} \dots & M[0] & M[1] & M[2] & M[3] & \dots \\ & M[0] & M[1] & M[2] & M[3] & \dots \\ & & M[0] & M[1] & M[2] & M[3] & \dots \\ & & & M[0] & M[1] & M[2] & M[3] & \dots \end{bmatrix} \quad (12)$$

and in the same way, we define H the band-Toeplitz matrix corresponding to the highpass analysis. So, we want $u_1 := [\dots, 1, 1, 1, 1, \dots]^T$ to be an *eigensignal* of the lowpass branch, hence we introduce

Definition 3.1 An orthonormal multiwavelet system is said to be balanced iff the lowpass synthesis operator L^T preserve $[\dots, 1, 1, 1, 1, \dots]^T$ i.e. $L^T u_1 = u_1$.

By the orthonormality relations

$$[L^T \ H^T] \begin{bmatrix} L \\ H \end{bmatrix} = I \quad \text{and} \quad \begin{bmatrix} L \\ H \end{bmatrix} [L^T \ H^T] = I$$

we get $L^T L + H^T H = I$, $LL^T = I$, $LH^T = 0$ and $HH^T = I$. Then $L^T u_1 = u_1$ implies $Lu_1 = u_1$ and so $Hu_1 = 0$ i.e. u_1 is cancelled by the highpass branch. Now, we can state

Theorem 3.1 The following conditions are equivalent

B0. $L^T u_1 = u_1$.

B1. $[1, 1]$ is a left eigenvector of $M(1)$ for $\lambda_0(1) = 1$.

B2. $\Phi(0) = [1, 1]^T$.

B3[†] $m_0(z) + m_1(z)$ has zeros on the unit circle at $j, -1, -j$.

B4. One can factorize $M(z) = \frac{1}{2} T(z^2) M_0(z) T^{-1}(z)$ with

$$T(z) := \begin{bmatrix} 1 & -1 \\ -z^{-1} & 1 \end{bmatrix} \quad \text{and} \quad M_0(1) \begin{bmatrix} 1 \\ 1 \end{bmatrix} = \begin{bmatrix} 1 \\ 1 \end{bmatrix}$$

Proof. The equivalences $[B0 \Rightarrow B1 \Rightarrow B2 \Rightarrow B3 \Rightarrow B0]$ were proved in [8], and $[B1 \Rightarrow B4]$ is a direct consequence of Theorem 4.1 in [9]. Assuming B4, we get

$$\begin{aligned} m_0(z) + m_1(z) &= [1 \quad 1] M(z^2) \begin{bmatrix} 1 \\ z^{-1} \end{bmatrix} \\ &= \frac{1}{2} [1 \quad 1] \begin{bmatrix} 1 & -1 \\ -z^{-4} & 1 \end{bmatrix} M_0(z^2) \frac{1}{1-z^{-2}} \begin{bmatrix} 1 & 1 \\ z^{-2} & 1 \end{bmatrix} \begin{bmatrix} 1 \\ z^{-1} \end{bmatrix} \\ &= \frac{1}{2} \left(\frac{1-z^{-4}}{1-z^{-1}} \right) [1 \quad 0] M_0(z^2) \begin{bmatrix} 1 \\ z^{-1} \end{bmatrix} \end{aligned}$$

and this is condition B3. ■

3.2. High Order Balancing

Definition 3.2 An orthonormal multiwavelet system is said to be balanced of order p iff the signals

$$\mathbf{u}_n := [\dots, (-2)^n, (-1)^n, 0^n, 1^n, 2^n, \dots]^\top$$

with $n = 0, \dots, p-1$ are preserved by the operator \mathbf{L}^\top i.e.

$$\mathbf{L}^\top \mathbf{u}_n = 2^{-n} \mathbf{u}_n \quad \text{for } n = 0, \dots, p-1$$

Similarly to the previous case, $\mathbf{L}^\top \mathbf{u}_n = 2^{-n} \mathbf{u}_n$ implies $\mathbf{L} \mathbf{u}_n = 2^n \mathbf{u}_n$ and $\mathbf{H} \mathbf{u}_n = \mathbf{0}$ for $n = 0, \dots, p-1$. The polynomial structure of the signal is captured up to degree $p-1$ by the lowpass branch coefficients. We then get

Theorem 3.2 The following conditions are equivalent

B0_p. $\mathbf{L}^\top \mathbf{u}_n = 2^{-n} \mathbf{u}_n$ for $n = 0, \dots, p-1$.

B3_p[†]. Defining $\alpha^{(n)}(z) := u_1^{(n)}(z)/u_0^{(n)}(z)$ where $u_0^{(n)}(z)$ and $u_1^{(n)}(z)$ are the formal series $u_i^{(n)}(z) := \sum_{k \in \mathbb{Z}} (2k+i)^n z^{-k}$, we impose $m_0(z) + \alpha^{(p)}(z^4)m_1(z)$ to have zeros of order p at $j, -1, -j$.

B4_p. $\mathbf{M}(z)$ can be factorized as

$$\mathbf{M}(z) = \frac{1}{2^p} \mathbf{T}^p(z^2) \mathbf{M}_{p-1}(z) \mathbf{T}^{-p}(z) \quad (13)$$

with $\mathbf{M}_{p-1}(1) \begin{bmatrix} 1 \\ 1 \end{bmatrix} = \begin{bmatrix} 1 \\ 1 \end{bmatrix}$ and $\mathbf{T}(z)$ defined as before.

Proof.

[B0_p ⇒ B4_p]: $\mathbf{M}(z)$ satisfies the conditions of Theorem 2.1 in [10] with $\mathbf{y}_n^\top := [0^n, 2^{-n}]$ for $n = 0, \dots, p-1$. Then, applying Corollary 4.3. from [10], we get the factorization

$$\mathbf{M}(z) = \frac{1}{2^p} \mathbf{C}_0(z^2) \dots \mathbf{C}_{p-1}(z^2) \mathbf{M}_{p-1}(z) \mathbf{C}_{p-1}^{-1}(z) \dots \mathbf{C}_0^{-1}(z)$$

with $\mathbf{C}_n(z) := \begin{bmatrix} a_n^{-1} & -a_n^{-1} \\ -z^{-1}b_n^{-1} & b_n^{-1} \end{bmatrix}$ and the FIR refinement

mask $\mathbf{M}_{p-1}(z)$ verifying $\mathbf{M}_{p-1}(1) \mathbf{r}_{p-1} = \mathbf{r}_{p-1}$ where $\mathbf{r}_n^\top := [a_n, b_n] = 2^{-n} [1, 1]$ obtained recursively from \mathbf{y}_n for $n = 0, \dots, p-1$. Thus $\mathbf{C}_n(z) = 2^n \mathbf{T}(z)$ and $\mathbf{M}_{p-1}(1) [1, 1]^\top = [1, 1]^\top$.

[B4_p ⇒ B3_p]: This is proved by induction on p [WEB]. Here, we will only verify the result for $p = 1, 2, 3$. The case $p = 1$ is a consequence of Theorem 3.1. For $p = 2$, we have

$$\begin{aligned} 2(m_0(z) + \alpha^{(2)}(z^4)m_1(z)) &= 2m_0(z) + (3 - z^{-4})m_1(z) \\ &= [2 \quad 3 - z^{-4}] \mathbf{M}(z^2) \begin{bmatrix} 1 \\ z^{-1} \end{bmatrix} \\ &= \frac{1}{4} \left(\frac{1 - z^{-4}}{1 - z^{-1}} \right)^2 [2 \quad -1] \mathbf{M}_1(z^2) \begin{bmatrix} 1 \\ z^{-1} \end{bmatrix} \end{aligned}$$

For $p = 3$

$$\begin{aligned} 8(m_0(z) + \alpha^{(3)}(z^4)m_1(z)) &= 8m_0(z) + (15 - 10z^{-4} + 3z^{-8})m_1(z) \\ &= \frac{1}{8} \left(\frac{1 - z^{-4}}{1 - z^{-1}} \right)^3 [8 + 3z^{-4} \quad -9] \mathbf{M}_2(z^2) \begin{bmatrix} 1 \\ z^{-1} \end{bmatrix} \end{aligned}$$

[†] Conditions B3 and B3_p were first given by Selesnick in [12].

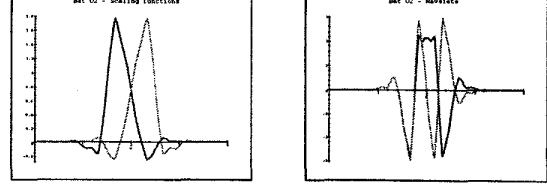

Figure 3: Order 2 balanced orthogonal multiwavelet: the scaling functions are flipped around 2, the wavelets are symmetric/antisymmetric, the length is 5 taps (2×2).

Hence the result for $p = 1, 2, 3$.

[B3_p ⇒ B0_p]: As mentioned in [12], condition B3_p says that the multirate system

$$-(\uparrow 4) - \boxed{m_0(z) + \alpha^{(p)}(z^4)m_1(z)} -$$

has zeros of order p at the roots of the unity $j, -1, j$. So, from the rank M wavelets theory (Theorem 2.1. in [4]), we get that this system preserves discrete polynomial sequences of degree $n = 0, \dots, p-1$, and since this multirate system is equivalent to the lowpass synthesis branch for polynomial sequences of degree up to $p-1$, this translates in time domain into condition B0_p. ■

4. REGULARITY

Now, one may wonder how these new results relate to the classical notions of regularity: approximation power and smoothness.

4.1. Approximation Power and Balancing Order

One says that $\phi(t)$ has approximation power m if one can exactly decompose polynomials $1, t, t^2, \dots, t^{m-1}$ using only ϕ_0, ϕ_1 and their integer translates, i.e. for $n = 0, \dots, p-1$, we have $t^n = \sum_k x_n^\top[k] \phi(t-k)$. Then, assuming that $\phi(t)$ is balanced of order p , we get that $\mathbf{M}(z)$ factorizes as in (13), so applying p times Theorem 2.6. from [10], we get that $\phi(t)$ has at least an approximation power of p .

Proposition 4.1 If an orthonormal multiwavelet system is balanced of order p , then the associated multiscale function $\phi(t)$ has an approximation power of at least p .

We can notice that the reciprocity is false: the DGHM [2] multiscale function has an approximation power of 2 but is not even balanced [8].

4.2. Smoothness and Balancing Order

From the previous proposition, and some results from [10] (Corollary 2.10.) showing links between the approximation power and the smoothness of the multiscale function (number of continuous derivatives or Sobolev exponent s i.e. $\int \|\Phi(\omega)\|^2 (1 + |\omega|^2)^s d\omega < \infty$), we get the following result

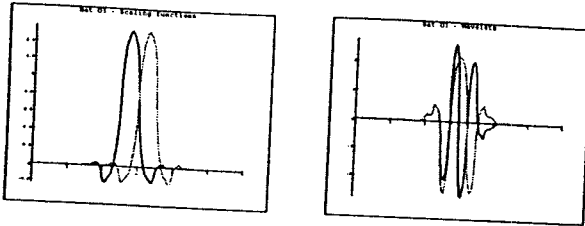

Figure 4: Order 3 balanced orthogonal multiwavelet: the scaling functions are flipped around 3, the wavelets are symmetric/antisymmetric, the length is 7 taps (2×2) and an estimate of the smoothness using Proposition 4.2 gives the Sobolev exponent $s = 1.71$.

Proposition 4.2 *If an orthonormal multiwavelet system has balancing order p and the spectral radius of $M_{p-1}(z)$ in the factorization (13) verifies $\rho(M_{p-1}(1)) < 2$, then defining*

$$\gamma_k := \frac{1}{k} \log_2 \rho(M_{p-1}(e^{-j\omega_{k-1}}) \dots M_{p-1}(e^{-j\omega_0})) \quad (14)$$

with $\{\omega_0, \dots, \omega_{k-1}\}$ invariant cycles of $\omega \mapsto 2\omega \pmod{2\pi}$, and $\gamma := \inf_k \gamma_k$, we get that $\phi(t)$ is at most $\lfloor p - \gamma - \frac{1}{2} \rfloor$ times continuously differentiable (and has at most Sobolev exponent $s = p - \gamma$).

Idea of proof. To characterize the smoothness, we are interested in the decay as $N \rightarrow \infty$ of $\Phi(2^{kN}\omega_0)$ for $\omega_0 \in [0, 2\pi]$. From the convergence (4), we form the truncated products $M_N(\omega) := \prod_{i=1}^N M(e^{-j\omega/2^i})$, then evaluating these on the invariant cycle $\{\omega_0, \dots, \omega_{k-1}\}$, we get

$$\begin{aligned} M_{kN}(2^{kN}\omega_0) &= \prod_{i=1}^{kN} M(e^{-j2^{-i}2^{kN}\omega_0}) \\ &= \left(M(e^{-j\omega_{k-1}}) \dots M(e^{-j\omega_0}) \right)^N \end{aligned} \quad (15)$$

then we study the asymptotic behavior of this product by looking at the eigenvalues of $M(e^{-j\omega_{k-1}}) \dots M(e^{-j\omega_0}) = U_k \Lambda_k U_k^T$, where $\Lambda_k = \text{diag}(\lambda_0^{(k)}, \lambda_1^{(k)})$. Then if $\rho(\Lambda_k) = \max\{|\lambda_0^{(k)}|, |\lambda_1^{(k)}|\} \geq 2^{-ki}$ then the scaling functions cannot have Sobolev exponent of more than i and so cannot be more than $\lfloor i - 1/2 \rfloor$ times continuously differentiable. Applying this to the factorization (13), we get the upper-bounds on smoothness. ■

Using results from the Perron-Frobenius theory [5], one can also find lower-bounds and prove that $s = p - \gamma$ is a good estimate of the Sobolev exponents of $\phi(t)$ and $\psi(t)$ [WEB]. For example in the case of the Haar multiwavelet, with $\omega_0 = 2\pi/3$, $\lambda_0 = 0$, $\lambda_1 = \frac{1}{4}$, it then proves that the scaling functions cannot be continuous. In the case of the DGHM multiwavelet, $\lambda_0 = \frac{1}{100}$, $\lambda_1 = \frac{1}{2}$, it proves that the scaling functions can be at most C^1 . They are in fact Lipschitz.

5. CONSTRUCTION OF HIGH ORDER BALANCED MULTIWAVELETS

Using the results above, we are now able to construct a Daubechies like family of multiwavelets. Namely, by impos-

ing the number of $T(z^2) \dots T^{-1}(z)$ in the factorization (13), we force the order of balancing. Then, we design $M_{p-1}(z)$ by imposing conditions of orthonormality (5) on $M(z)$, flipping property on $m_0(z), m_1(z)$ (i.e. $m_1(z) = z^{-2L+1}m_0(z)$) and linear phase on $n_0(z)$ and $n_1(z)$. Using a Gröbner bases approach and the program Singular [3], we have been able to construct all the multiwavelets of compact support $\subset [0, 6]$ with flipped scaling functions and symmetric/antisymmetric wavelets for order 2 and 3 of balancing [WEB]. Fig. 3 and Fig. 4 show some examples of high order balanced multiwavelets with these properties.

6. CONCLUSION

By introducing the concept of high order balancing, we have clarified the issue of general design of multiwavelets. We have proved that this concept was equivalent to a natural counterpart of the zeros at π condition. With these results, we made it possible to design general families of high order balanced multiwavelets with the required properties for practical signal processing (preservation/cancellation of discrete-time polynomial signals in the lowpass/highpass subbands, FIR, linear phase and orthogonality). Multiwavelets are eventually asserting themselves as convincing alternative tools for digital signal processing.

7. REFERENCES

- [1] A.Cohen, I.Daubechies and G.Plonka, "Regularity of Refinable Function Vectors", J. Fourier Anal. & Appl., 1997.
- [2] G.Donovan, J.Geronimo, D.Hardin and P.Massopust, "Construction of Orthogonal Wavelets Using Fractal Interpolation Functions", SIAM J. Math. Anal., 1996.
- [3] G.-M.Greuel, G.Pfister, and H.Schönemann, "Singular Reference Manual", University of Kaiserslautern, 1997. <http://www.mathematik.uni-kl.de/~zca/Singular>
- [4] P.N.Heller, "Rank M Wavelets With N Vanishing Moments", Vol. 16, SIAM J. Math. Anal., 1995.
- [5] P.N.Heller and R.O.Wells JR., "Sobolev Regularity for Rank M Wavelets", preprint, 1996.
- [6] Q.Jiang, "On the Design of Multifilter Banks and Orthogonal Multiwavelet Bases", preprint, 1997.
- [7] J.Lebrun and M.Vetterli, "Balanced MultiWavelets", Proc. ICASSP, 1997.
- [8] J.Lebrun and M.Vetterli, "Balanced MultiWavelets - Theory and Design", IEEE Trans. on SP, Special Issue, to appear, 1998.
- [9] G.Plonka, "Approximation Order Provided by Refinable Function Vectors", Const. Approx., 1994.
- [10] G.Plonka and V.Strela, "Construction of Multi-scaling Functions with Approximation and Symmetry", SIAM J. Math. Anal., 1995.
- [11] P.Rieder and J.A.Nossek, "Multiwavelets Transforms Based on Several Scaling Functions: Design and Implementation", preprint, 1997.
- [12] I.W.Selesnick, "Multiwavelet Bases with Extra Approximation Properties", preprint 1997.