

UNIVERSITY  
OF MISSOURI  
**BULLETIN**  
COLUMBIA, MISSOURI

**DIGITAL COMPUTER ANALYSIS  
OF PASSIVE NETWORKS  
USING  
TOPOLOGICAL FORMULAS**

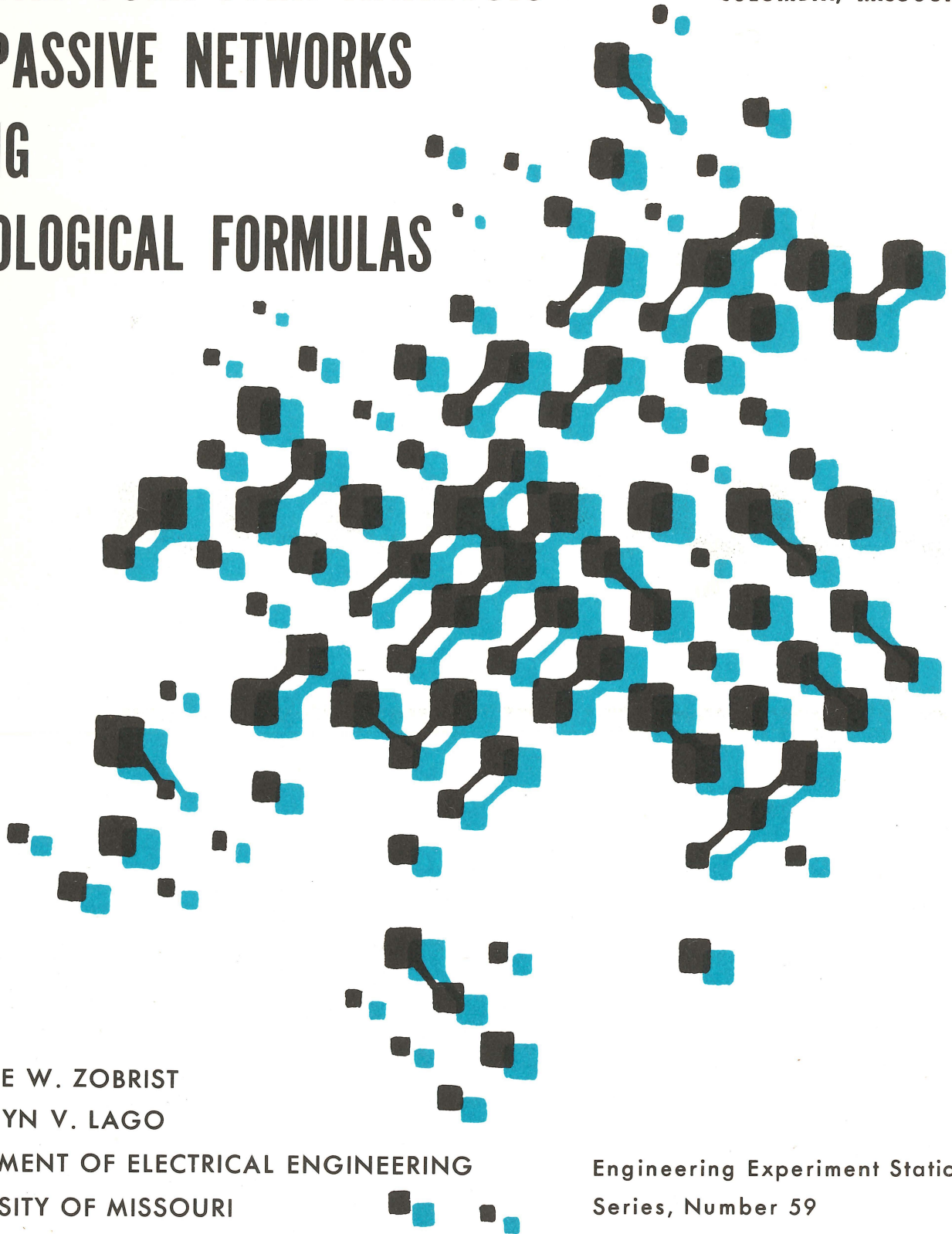

GEORGE W. ZOBRIST  
GLADWYN V. LAGO  
DEPARTMENT OF ELECTRICAL ENGINEERING  
UNIVERSITY OF MISSOURI  
COLUMBIA, MISSOURI

Engineering Experiment Station  
Series, Number 59

March 29, **1965**

THE UNIVERSITY OF MISSOURI BULLETIN

---

VOLUME 66, NUMBER 12 ENGINEERING EXPERIMENT STATION SERIES NUMBER 59

---

Sam B. Shirky, Director, Technical Education Services

Mary Kathryn Yeargain, Editor

Published five times monthly during March, April, September and October; four times monthly during August and November; three times monthly during January and May; twice monthly during February, June and July; once during December, by the University of Missouri Bulletin Editor's Office-206S Technical Education Services Building, 417 South Fifth St., Columbia, Mo. Second class postage paid at Columbia, Missouri, 1000. March 29, 1965.

## ACKNOWLEDGEMENTS

This paper was partially supported by the National Science Foundation and the University of Missouri Engineering Experiment Station. This paper also represents a portion of the work in progress on a Ph.D. dissertation, by the first author, at the University of Missouri, Columbia, Missouri.

## CONTENTS

I.	Introduction . . . . .	1
II.	Kirchhoff's Topological Rules . . . . .	2
III.	Concept of the Complete Graph . . . . .	4
IV.	Method of Obtaining Results on Computer . . . . .	6
V.	Examples . . . . .	8
VI.	Conclusions . . . . .	12
VII.	Bibliography . . . . .	13

# DIGITAL COMPUTER ANALYSIS OF PASSIVE NETWORKS\*

## USING TOPOLOGICAL FORMULAS

George W. Zobrist  
and Gladwyn V. Lago  
Department of Electrical Engineering  
University of Missouri  
Columbia, Missouri

### I. Introduction

In a classic paper by Kirchhoff<sup>1</sup> the rules for computation of network response, in terms of branch resistances, by means of topological quantities were presented. About 40 years later Maxwell<sup>2</sup> presented similar rules, dual to those of Kirchhoff, in terms of conductances. These rules will be referred to as Kirchhoff's rules. Interest has been generated in the last few years with applications to synthesis<sup>3, 4, 5</sup> and investigations of the applicability of these topological rules for analysis of networks using the digital computer have been presented by Mayeda and Van Valkenburg,<sup>6</sup> Hobbs<sup>7</sup> and MacWilliams.<sup>8</sup>

The intent of this paper is to present a general approach whereby all trees for a  $v$  vertex complete graph are generated and any subset of trees for a subgraph of the complete graph of  $n$  vertices, where  $n \leq v$ , can be determined. The network response, through use of Kirchhoff's rules, can be determined for any linear passive network (with no mutual inductances) once the trees are found for the networks graph.

In conjunction with this aim two problems had to be solved: First a method of obtaining the trees for a  $m$  vertex complete graph from a

\* Presented at the 2<sup>nd</sup> Annual Allerton Conference on Circuit and System Theory, University of Illinois, Urbana, Illinois; to appear in Conference Proceedings, September 28-30, 1964.

v vertex complete graph. The trees for a subgraph of m vertices can be readily found from a complete graph of m vertices. Secondly, a least upper bound on the number of 2-trees (2-cotrees). This is required for computer storage reasons, since one has to compare 2-trees (2-cotrees) for determination of the sign of each 2-tree (2-cotree) product, in transfer quantities.

Computer programs were written employing these ideas and checked for graphs with up to six vertices. In principle the number of vertices allowed is limited only by storage capacity of the computer and time. Fortran II-D language was chosen since it seems to be in rather wide spread use.

## II. Kirchhoff's Topological Rules

The main purpose of this section will be to state Kirchhoff's topological rules in a notation which was found rather useful in the formulation of the computer programs. The reader is referenced to excellent discussions in either Seshu<sup>9</sup> or Weinberg<sup>10</sup> for detailed developments. Definitions of terms used are the same as found in Seshu.<sup>9</sup>

While the original rules were formulated only for resistances (conductances) they are easily extended to the R-L-C case,<sup>10</sup> in the remainder of the paper this will be assumed.

If a current source is attached parallel to a branch which includes an element  $y_m$ , see Figure 1(a), the voltage response, at this pair of terminals is given by

$$V(s) = I_g(s) \frac{\sum_{k=1}^{\text{Trees}} \frac{\partial}{\partial y_m} (y_{k1} \cdots y_{k(v-1)})}{\sum_{G=1}^T (y_{G1} \cdots y_{G(v-1)})}$$

where the denominator is the sum of all tree products for the given networks graph of e edges and v vertices and the numerator is the sum of all 2-tree products, with respect to  $y_m$ . The notation  $y_{k1} \cdots y_{k(v-1)}$  refers to the tree product of the k<sup>th</sup> tree, which consists of the v-1 distinct edges of the graph that form the k<sup>th</sup> tree. Where  $y_{k1}$  is not necessarily equal to  $y_{g1}$ , if  $g \neq k$ . If  $y_m$  or  $y_n$  occur in a tree product, the  $\frac{\partial}{\partial y_m}$

or  $\frac{\partial}{\partial y_n}$  of  $(y_{k1} \dots y_{k(v-1)}) \neq 0$ , if not, it is zero.

If a current source is attached to a pair of terminals, see Figure 1(b), the voltage response at a pair of terminals is given by

$$V(s) = I_g(s) \frac{\sum_{K=1}^T \sum_{F=1}^T + \left( \frac{\partial}{\partial y_m} (Y_{K1} \dots Y_{K(v-1)}) \cap \frac{\partial}{\partial y_n} (Y_{F1} \dots Y_{F(v-1)}) \right)}{\sum_{G=1}^T (Y_{G1} \dots Y_{G(v-1)})}$$

The denominator is interpreted as before but the numerator takes on different significance. The numerator represents the algebraic sum of all common 2-trees, where the 2-trees are originally separated into two sets, one consisting of all tree products containing  $y_m$ , the other set those tree products containing  $y_n$ . The common terms in these two sets are the desired 2-tree products.

The + sign is used if upon shorting of the edges of the above mentioned 2-tree product one finds that the current source will cause the assigned positive voltage drop, negative if a negative voltage drop is produced.

If a voltage source is placed in series with a branch which contains  $z_m$ , see Figure 1(c), the current response in this branch is given by

$$I(s) = V_g(s) \frac{\sum_{D=1}^T \frac{\partial}{\partial z_m} (Z_{D1} \dots Z_{DL})}{\sum_{H=1}^T (Z_{H1} \dots Z_{HL})}$$

where  $L = e - (v-1)$ . The notation  $z_{k1} \dots z_{kL}$  is similar to that of the admittance equations, except now it is the  $k^{\text{th}}$  cotree and  $L$  distinct edges.

The denominator is the sum of cotree products, for a given graph of  $e$  edges and  $v$  vertices and the numerator is the sum of all 2-cotree products, with respect to  $z_m$ .

If a voltage source is placed in series with a branch which contains  $z_m$ , see Figure 1(d), the current response in a branch which contains  $z_n$

is given by,

$$I(s) = V_g(s) \frac{\sum_{D=1}^T \sum_{C=1}^T + \left( \frac{\partial}{\partial Z_M} (Z_{D1} \dots Z_{DL}) \cap \frac{\partial}{\partial Z_N} (Z_{C1} \dots Z_{CL}) \right)}{\sum_{H=1}^T (Z_{H1} \dots Z_{HL})}$$

The denominator is interpreted the same as in the driving point impedance case and the numerator consists of the algebraic sum of the common 2-cotree terms. Where the + sign is used if upon removal of the 2-cotree under investigation from the network, the voltage source causes a current which is confluent with the assigned positive direction, negative if not.

### III. Concept of the Complete Graph

It is a well known fact, see Cayley,<sup>11</sup> that the number of trees in a complete graph, i. e., a graph with a single edge from every vertex to every other vertex, is  $v^{v-2}$ . There are also many established methods of enumerating all the trees of a graph.<sup>12-15</sup> The method of obtaining trees in this paper follows a theorem stated in Seshu,<sup>9</sup> i. e., if  $G_s$  is a subgraph of a connected graph  $G$  of  $v$  vertices, and  $G_s$  consists of  $v-1$  edges and no circuits, then  $G_s$  is a tree of  $G$ . This theorem was found to be easily implemented on the digital computer and since the intent was to generate the complete set of trees only once, time was not of first importance.

It was of prime importance to be able to obtain the trees of a complete graph of  $m$  vertices from the trees of a complete graph of  $v$  vertices,  $m < v$ . This can be done in the following manner. Assume a complete graph of  $v$  vertices. This complete graph has  $v(v-1)/2$  edges. Now remove edge  $(1,v)$  and let vertices 1 and  $v$  coalesce, the trees of this resultant graph contains all trees (when edge  $(1,v)$  is included in each tree of the resultant graph) which contain edge  $(1,v)$ . Remove edge  $(1,v)$  from the complete graph of  $v$  vertices. Now remove edge  $(2,v)$  and let vertices 2 and  $v$  coalesce, the resultant graphs trees contain all trees of the original complete graph, which contain edge  $(2,v)$  but not edge  $(1,v)$ , again when edge  $(2,v)$  is included. Continue in this manner until edge  $(v-1,v)$  is reached. This development separates the



trees of a complete graph of  $v$  vertices into  $v-1$  distinct sets. The first set contains all the trees which have edge  $(1,v)$ , the second set consists of those trees which do not have edge  $(1,v)$ , but do have edge  $(2,v)$ . This process is continued until one reaches the last set, this set contains edge  $(v-1,v)$  but not edges  $(1,v)$ ,  $(2,v)$ ,  $\dots$ ,  $(v-2,v)$ . Collecting all the trees for the  $v-1$  sets, one has obtained the trees of the  $v$  vertex complete graph. Of interest is the last set of trees, those which contain edge  $(v-1,v)$  but not edges  $(1,v), \dots, (v-2,v)$ . This set is found to contain the trees of a complete graph of  $v-1$  vertices, see Figure 2.

This can be shown to be a valid development by considering the nodal determinant of a  $v$  vertex complete graph, since the above can be obtained by expanding the determinant in a particular manner. In fact, in this expansion, see Figure 2, each resultant subgraph is a quasi-complete graph, i. e., some vertices may have parallel edges between them. In summary, one may find the trees of a  $m$  vertex complete graph from a  $v$  vertex complete graph, quite easily, by considering only those trees which contain certain edges. Another interesting point is that this procedure can also be used to find the trees of a complete graph of  $v + 1$  vertices from a complete graph of  $v$  vertices.

If one is to store 2-trees (2-cotrees) in an efficient manner, a least upper bound has to be determined, for them. It is asserted that the number of 2-trees for a complete graph of  $v$  vertices is given by  $2 v^{v-3}$ . This can be seen in the following manner. Consider the following expression,

$$\begin{array}{l} \text{Total \# edges} \\ \text{for complete} \\ \text{graph} \end{array} \quad \times \quad \begin{array}{l} \text{Total \# 2-trees for} \\ \text{complete graph for a} \\ \text{given edge (i,j)} \end{array} \quad \times \quad \frac{1}{v-1}$$

Now due to symmetry the total number of 2-trees for edge  $(i,j)$  is the same as edge  $(k,1)$ , hence if one takes the product of the first two terms one obtains a term which would be a tree, since this is the reverse process of obtaining a 2-tree. But enumerating all these trees would give repetitions since there are  $v-1$  terms in each product, hence each product will occur in  $v-1$  sets of the above total.

Therefore, if one multiplies by the factor  $\frac{1}{v-1}$ , this expression can be equated to the total number of trees in a complete graph of  $v$  vertices. Upon substitution for the total number of edges its equivalent in terms of  $v$ , one has

$$\frac{v(v-1)}{2} \times \# \text{ 2-trees} \times \frac{1}{v-1} = v^{v-2} \quad \text{or} \quad \# \text{ 2-trees} = 2 v^{v-3}.$$

This establishes a least upper bound for the number of 2-trees in a graph of  $v$  vertices, with no parallel edges. If parallel edges are to be allowed, a similar development shows that the number of 2-trees for a full graph, i. e., a complete graph with  $p$  parallel edges between each vertex, is  $2p(pv)^{v-3}$ .

The number of 2-cotrees for a complete graph of  $v$  vertices and a full graph of  $v$  vertices and  $p$  parallel edges, is found to be

$$\begin{aligned} \# \text{ 2-cotrees} &= v^{v-2} - 2v^{v-3} && \text{(complete)} \\ &= p(pv)^{v-2} - 2p(pv)^{v-3} && \text{(full)}. \end{aligned}$$

This is easily deduced since if a tree contains edge  $(i,j)$  the associated cotree does not and vice versa.

#### IV. Method of Obtaining Results on Computer

Edges are designated by the unordered pair  $(v_i, v_j)$ , i. e., the edge connecting vertex 4 to vertex 7 would be  $(4,7)$ . This designation allows efficient processing on the digital computer.

Trees are generated in the following manner; form all combinations of the  $v(v-1)/2$  edges taken  $v-1$  at a time and test each combination to see if it is a tree or not. This test can be done by removing all free edges, i. e., any edge connected to a vertex of degree 1. After this removal has been done for the original combination, remove the free edges of the resulting combination of edges. Continue this until no free edges remain.

In doing this the original graph can be reduced to all isolated vertices (if edges and vertices are considered to be separate) if it is a tree.

Example of method of finding the trees for a 4 vertex complete graph. The edges are: (1,2) (1,3) (1,4) (2,3) (2,4) (3,4). Now form the combinations: (1,2) (1,3) (1,4); (1,2) (1,3) (2,3); (1,2) (1,3) (2,4); (1,2) (1,3) (3,4); (1,2) (1,4) (2,3); (1,2) (1,4) (2,4); (1,2) (1,4) (3,4); (1,2) (2,3) (2,4); (1,2) (2,3) (3,4); (1,2) (2,4) (3,4); (1,3) (1,4) (2,3); (1,3) (1,4) (2,4); (1,3) (1,4) (3,4); (1,3) (2,3) (2,4); (1,3) (2,3) (3,4); (1,3) (2,4) (3,4); (1,4) (2,3) (2,4); (1,4) (2,3) (3,4); (1,4) (2,4) (3,4). The second, sixth and thirteenth combinations do not form trees. These are all the combinations which need to be formed, the next one is (2,3) (2,4) (3,4) and since each vertex must be included in a tree every combination after the last one listed need not be formed. In general there is a saving of  $\left( \frac{v(v-1) - (v-1)}{2} \right)_{v-1}$  combinations to be tested in forming this way.

If all vertices are not isolated and no more free edges are encountered the graph contains at least one circuit, since no vertices have degree 1, see Figure 3, hence the subgraph for this combination does not form a tree.

In Figure 4 is a somewhat simplified flow diagram of the computer program for calculating driving point and transfer admittances.

Trees are stored on the IBM Disk Pack 1311 as floating point numbers to utilize to the maximum, available storage space, although in doing this one trades off time, in converting back to fixed point for calculation purposes. As each tree is drawn off the disk a check is performed to see if it is a valid tree for the complete graph specified, this is done by checking to see if the tree product contains only the edges  $(v-1,v)$ ,  $(v-2,v-1)$ ,  $\dots$ ,  $(i-1,i)$ , and no other edges containing  $v,v-1, \dots, i$ , where  $i-1$  is the number of vertices in the specified complete graph.

The tree product is checked to see if it is zero, for the given subgraph of the complete graph with  $i-1$  vertices, if so, the next tree on the disk is investigated. If the tree product is non-zero the computer proceeds to find out whether it is a 2-tree. If it contains  $y_m$ , see Figure 1(b), set  $v_m$  to 1, which is equivalent to performing the operation  $\partial/\partial y_m$ , since each tree product is linear in any given  $y$ .

Convert the 2-tree product to floating point and store on the disk. Similarly, if transfer quantities are desired, check for 2-trees containing  $y_n$ , see Figure 1(b), these are also stored on the disk. The necessity for determining a least upper bound on 2-trees now becomes evident, see Figure 5.

Since quantities on the disk cannot be given variable names, and there is no pattern as to when the 2-trees for  $y_m$  and  $y_n$  will be encountered, a method such as this in Figure 5, alleviates devising complicated recalling routines.

The 2-trees are compared and the common ones found and checked for sign by the following intuitive scheme, see Figure 6, due to Percival.<sup>14</sup>

If at starting at 1 one ends up at 2' rather than 2, a negative sign is associated with the 2-tree product. To keep track of powers of  $s$  in the various tree and 2-tree products one makes the following association  $s^{-1} \rightarrow -1$ ,  $s^1 \rightarrow 1$ ,  $s^0 \rightarrow 0$ , where each term in a product is assigned either 1, -1, or 0 and then all terms summed.

The procedure for driving point admittance is simpler since only the 2-trees for  $y_m$  are found and hence no comparison or determination of sign is needed.

In Figure 7 is a simplified flow diagram of the computer program for calculating driving point and transfer impedances.

In determining impedance functions one needs to find the cotrees, this can be done by negation. If one removes from the edges of the graph, the edges of the non-zero tree product under investigation, the remaining edges form a cotree for the given graph. Then each step is performed as was done for the admittance case. One exception is that one has to remove the 2-cotree from the edges of the graph to check for a + or - sign on common 2-cotrees. This is expected since 2-cotrees can be considered to be the dual of 2-trees.

## V. Examples

### Y (s) Transfer Admittance

Values of elements are for admittances. Correspondence of  $(i,j) = k$  is made for input  $i$ . e.,  $(5,6) = 15$ ,  $(3,4) = 10$ , etc. Correspondence is made for 6 node complete graph.

Input:

Card #1

- 1. Number of vertices = 6
- 2. Edge which current source is in parallel with = 1

Card #2

- 1. Edge across which voltage response is to be calculated = 10
- 2. Vertex which is connected to arrowhead of current source = 1
- 3. Vertex which is connected to + of  $V(s)$  = 4
- 4. Vertex which is connected to - of  $V(s)$  = 3

Card #3

Admittance values of edges of graph of given network

(1,2) (1,3) (1,4) (1,5) (1,6) (2,3) (2,4) (2,5) (2,6) (3,4) (3,5) (3,6)  
 1. 0. 0. 1. 0. 0. 0. 0. 1. 1. 1. 1.

(4,5) (4,6) (5,6)  
 1. 1. 0.

Card #4

Value of admittance element, according to whether it is a

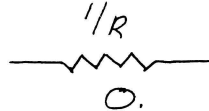
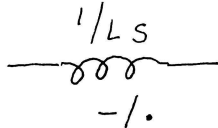
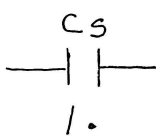

1. 0. 0. 1. 0. 0. 0. 0. -1. 0. -1. 1. 0. 1. 0.

Output:

Y (s)

| Numerator |     | Denominator |     |
|-----------|-----|-------------|-----|
| 10.0      | SP0 | -1.0        | SP0 |
| 8.0       | SP1 | 1.0         | SP1 |
| 9.0       | SP2 | 0.0         | SP2 |
| 4.0       | SP3 | 0.0         | SP3 |
| 1.0       | SP4 | 0.0         | SP4 |
| 0.0       | SP5 | 0.0         | SM1 |
| 0.0       | SM1 | 0.0         | SM2 |
| 0.0       | SM2 | 0.0         | SM3 |
| 0.0       | SM3 | 0.0         | SM4 |
| 0.0       | SM4 |             |     |
| 0.0       | SM5 |             |     |

Y (s) Driving Point Admittance

Input:

Card #1

- 1. Number of vertices = 6

2. Edge which current source is in parallel with = 1

Card #2

Admittance values of edges of graph of given network

1. 0. 0. 1. 0. 0. 0. 0. 1. 1. 1. 1. 1. 1. 0.

Card #3

Value of admittance element, according to whether it is a

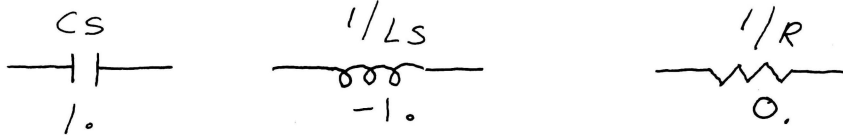

1. 0. 0. 1. 0. 0. 0. 0. 0. -1. 0. -1. 1. 0. 1. 0.

Output:

Y (s)

| Numerator |     | Denominator |     |
|-----------|-----|-------------|-----|
| 10.0      | SP0 | 5.0         | SP0 |
| 8.0       | SP1 | 8.0         | SP1 |
| 9.0       | SP2 | 4.0         | SP2 |
| 4.0       | SP3 | 1.0         | SP3 |
| 1.0       | SP4 | 0.0         | SP4 |
| 0.0       | SP5 | 6.0         | SM1 |
| 0.0       | SM1 | 0.0         | SM2 |
| 0.0       | SM2 | 0.0         | SM3 |
| 0.0       | SM3 | 0.0         | SM4 |
| 0.0       | SM4 |             |     |
| 0.0       | SM5 |             |     |

Z (s) Transfer Impedance

Values of elements are for impedances. Correspondence of (i,j) = k is made for input, i. e., (3,4) = 10, (5,6) = 15, etc. Correspondence is made for 6 node complete graph.

Input:

Card #1

1. Number of vertices = 4

2. Edge which voltage source is inserted in series with = 1

3. Total number of edges in graph = 6

Card #2

1. Edge through which current response is to be calculated = 10

2. Vertex which is connected to + side of  $V_g(s) = 1$

3. Vertex which is situated at end opposite arrow head of  $I(s) = 3$
4. Vertex which is situated at arrowhead of  $I(s) = 4$

Card #3

Impedance values of edges of graph of given network

1. 2. 1. 0. 0. 1. 1. 0. 0. 3. 0. 0. 0. 0. 0.

Card # 4

Value of impedance element, according to whether it is a

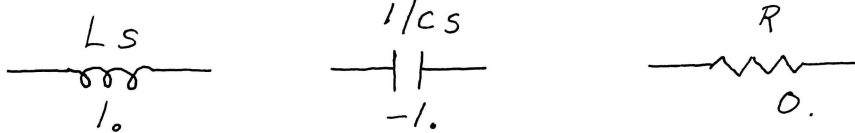

0. 1. -1. 0. 0. 1. -1. 0. 0. 1. 0. 0. 0. 0. 0.

Output:

$Z(s)$

| Numerator |     | Denominator |     |
|-----------|-----|-------------|-----|
| 9.0       | SP0 | -1.0        | SP0 |
| 22.0      | SP1 | 0.0         | SP1 |
| 11.0      | SP2 | 0.0         | SP2 |
| 0.0       | SP3 | 0.0         | SM1 |
| 3.0       | SM1 | 0.0         | SM2 |
| 1.0       | SM2 |             |     |
| 0.0       | SM3 |             |     |

$Z(s)$  Driving Point

Input:

Card #1

1. Number of vertices = 4
2. Edge which voltage source is inserted in series with = 1
3. Total number of edges in graph = 6

Card #2

Impedance values of edges of graph of given network

1. 2. 1. 0. 0. 1. 1. 0. 0. 3. 0. 0. 0. 0. 0.

Card #3

Value of impedance element, according to whether it is a

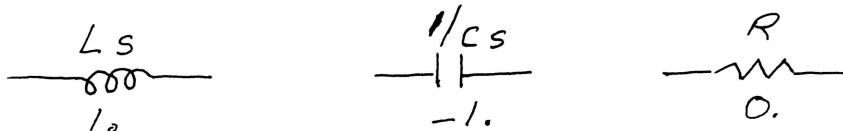

0. 1. -1. 0. 0. 1. -1. 0. 0. 1. 0. 0. 0. 0. 0.

Output:

Z (s)

| Numerator |     | Denominator |     |
|-----------|-----|-------------|-----|
| 9.0       | SP0 | 9.0         | SP0 |
| 22.0      | SP1 | 0.0         | SP1 |
| 11.0      | SP2 | 11.0        | SP2 |
| 0.0       | SP3 | 0.0         | SM1 |
| 3.0       | SM1 | 1.0         | SM2 |
| 1.0       | SM2 |             |     |
| 0.0       | SM3 |             |     |

See Figure 8, for network configurations used in examples.

VI. Conclusions

The method is completely general in that the response for any network of  $n$  vertices can be found from the knowledge of the trees for a complete graph of  $v$  vertices, where  $n \leq v$ .

In using this approach the size network (number of vertices) which can be handled is reached rather fast, on IBM 1620 with disk pack, only graphs with up to 7 vertices can be accommodated. On the IBM 1620 it takes approximately one second to perform a complete cycle, i. e., time lapse between drawing off the  $j^{\text{th}}$  tree to drawing off the  $(j+1)^{\text{th}}$  tree.

Some rather interesting results have been obtained. They are the establishment of a least upper bound on 2-trees (2-cotrees) and a method of obtaining the trees of a complete graph of  $m$  vertices from one of  $v$  vertices, where  $m < v$ .



## VII. Bibliography

1. Kirchhoff, G., "Über die Auflösung der Gleichungen, auf welche man bei der Untersuchungen der Linearen Verteilung Galvanischer Ströme geführt wird," Poggendorf Ann. Physik, 72, pp. 497-508 (1847): English translation, Trans. Inst. Radio Engrs. CT-5, pp. 4-7 March 1958.
2. Maxwell, J. C., Electricity and Magnetism, 1, Chap. VI and Appendix, pp. 403-410. Oxford: Clarendon Press, 1892.
3. Seshu, S., Topological Considerations in the Design of Driving Point Functions, Trans. Inst. Radio Engrs. CT-2, pp. 356-367; Dec. 1955.
4. Kim, W. H., A New Method of Synthesis of Driving Point Functions, Interim Tech. Rpt. no. 1, U.S. Army Contract no. DA-11-022-PRD-1938, U. of Ill.; April 1956.
5. Talbot, A., Some Fundamental Properties of Networks without Mutual Inductances, Proc. Inst. Elect. Engrs., 102, pp. 167-175; Sept. 1955.
6. Mayeda, W., and Van Valkenburg, M. E., Network Analysis and Synthesis by Digital Computer, Inst. Radio Engrs. Convention Record, (part 2), 5, pp. 137-144; 1957.
7. Hobbs, E. W., Topological Network Analysis as a Computer Program (Discussion), IRE Trans. PGCT-6, pp. 135-36; 1959.
8. MacWilliams, F. J., Topological Network Analysis as a Computer Program, IRE Trans. PGCT-5, pp. 228-29; 1958.
9. Seshu, S., and Reed, M. B., Linear Graphs and Electrical Networks, Reading, Mass., Addison-Wesley, 1961.
10. Weinberg, L., Network Analysis and Synthesis, New York, McGraw-Hill, 1962.
11. Cayley, A., A Theorem on Trees, Quarterly Journal of Pure and Applied Math, Vol. XXIII, pp. 376-378; 1889
12. Nakagawa, N., On Evaluation of the Graph Trees and the Driving Point Admittance, IRE Transactions of Circuit Theory CT-5, No. 2 pp. 122-127; June 1958.
13. Cummins, R. L., and Thomason, L. C., An Efficient Tree-listing Program, Southwestern IEEE Conference, 1964.
14. Percival, W. S., Solution of Passive Electrical Networks by Means of Mathematical Trees, J. Inst. Elect. Engrs. (London), 100 (part III), pp. 143-150; 1953.
15. Hakimi, S. S., On Trees of a Graph and Their Generation, Franklin Institute, Journal, Volume 272, No. 5, 347-359; 1961.

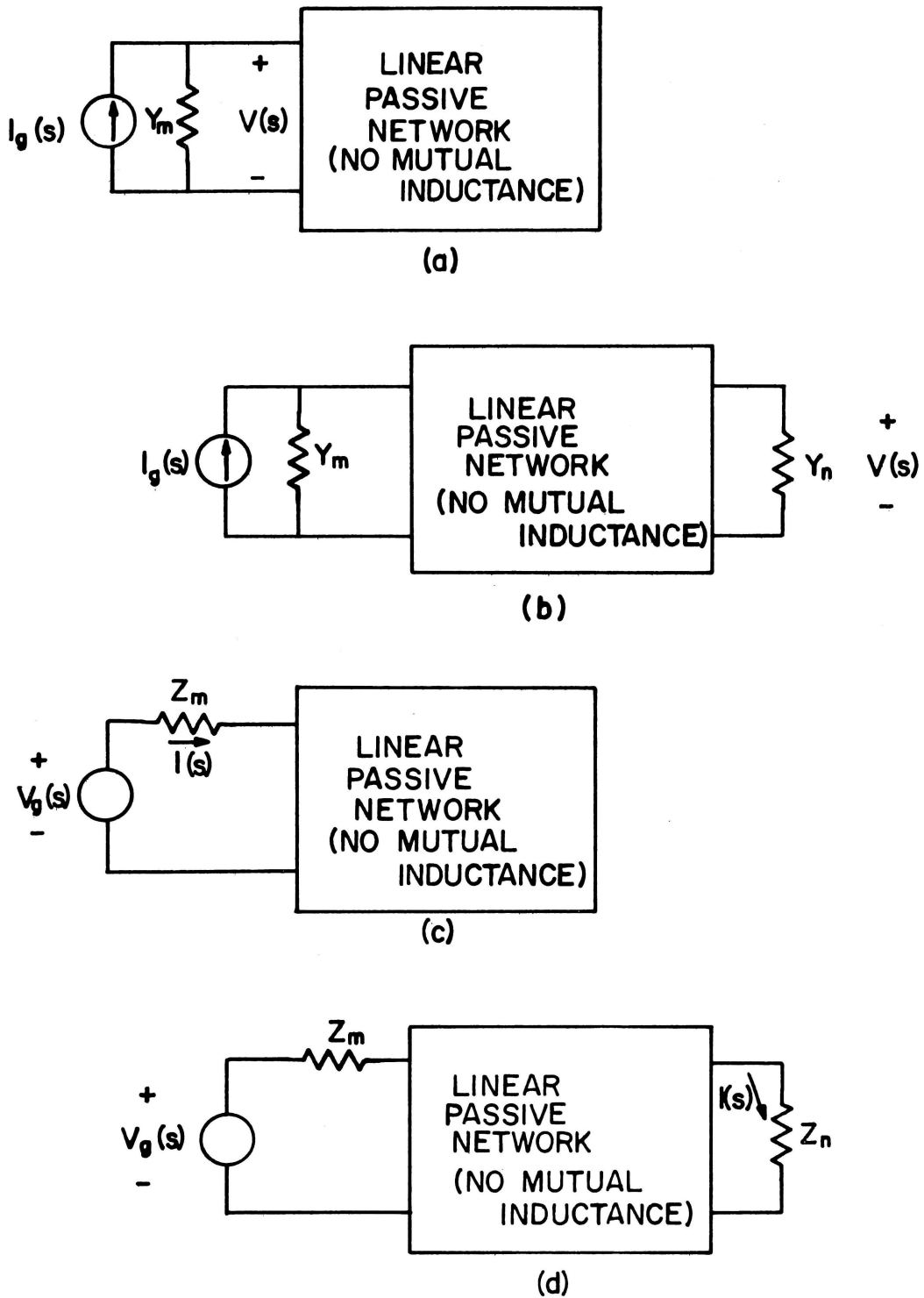

FIGURE 1. CONFIGURATIONS FOR APPLICATION OF KIRCHHOFF'S TOPOLOGICAL RULES

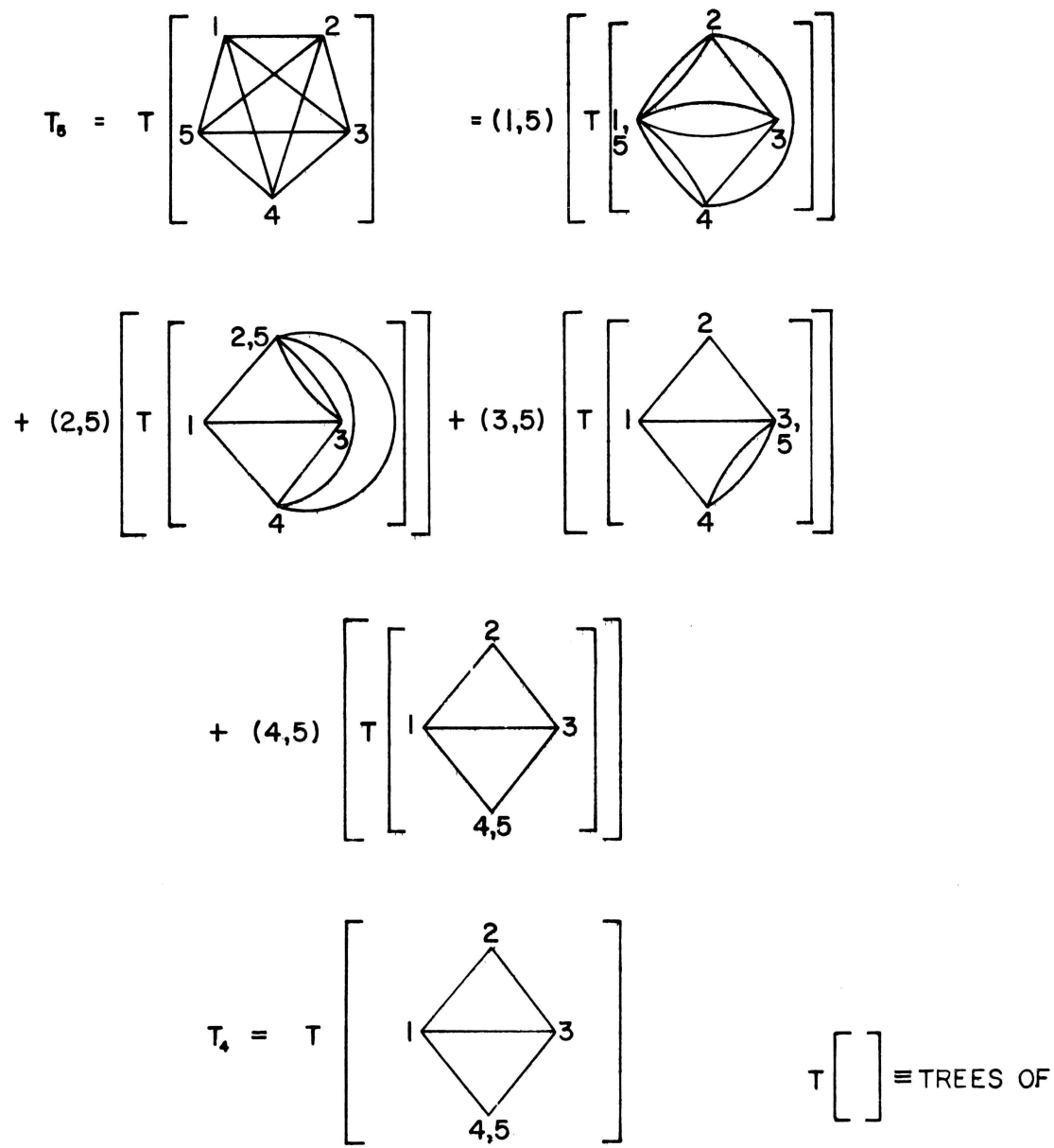

FIGURE 2. METHOD OF OBTAINING TREES OF 4VERTEX COMPLETE GRAPH FROM 5VERTEX COMPLETE GRAPH

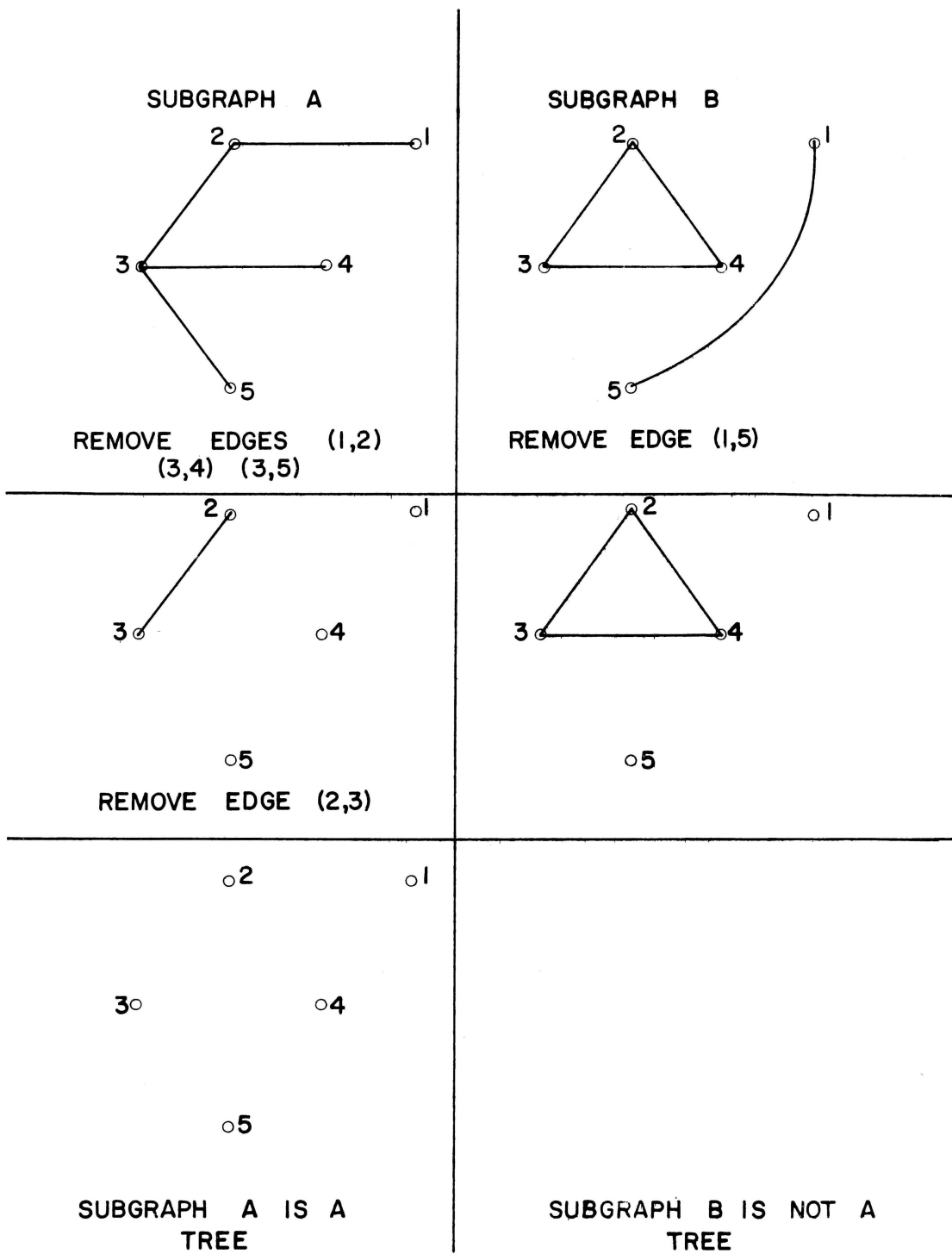

FIGURE 3. TEST FOR TREES

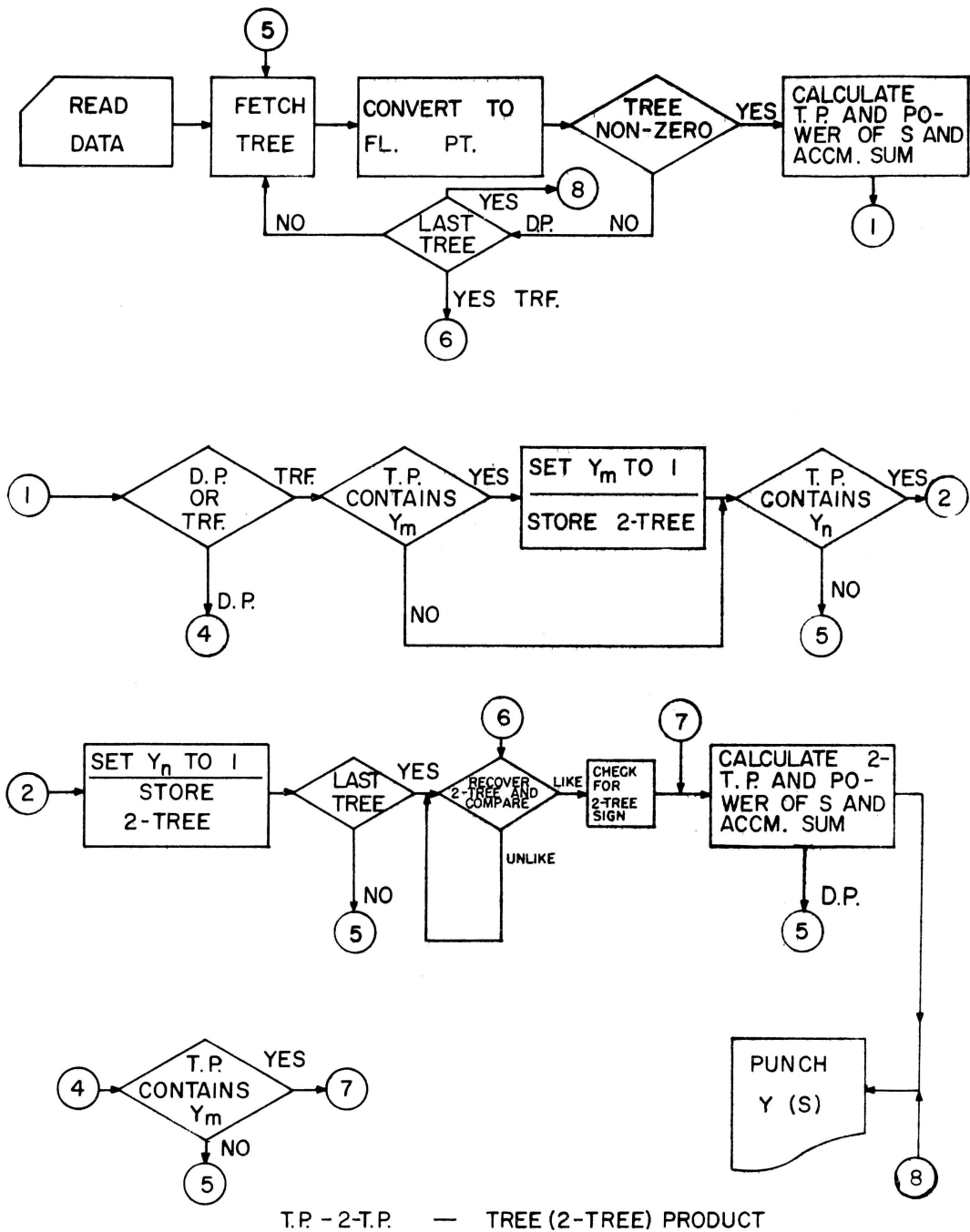

FIGURE 4. SIMPLIFIED FLOW DIAGRAM FOR  $Y(S)$  DRIVING POINT AND TRANSFER ADMITTANCE

| TREES | 2-TREES ( $y_m$ ) OR<br>2-COTREES ( $z_m$ ) | 2-TREES ( $y_n$ ) OR<br>2-COTREES ( $z_n$ ) |
|-------|---|---|
| 1     | $V^{V-2}$                                   | $V^{V-2} + 2V^{V-3}$                        |
|       | 2-TREES                                     | 2-TREES                                     |
|       | 2-COTREES                                   | 2-COTREES                                   |
|       | $2V^{V-2} - 2V^{V-3}$                       | $V^{V-2} + 2(2V^{V-3})$                     |
|       |   | $3V^{V-2} - 4V^{V-3}$                       |

FIGURE 5. DISK STORAGE

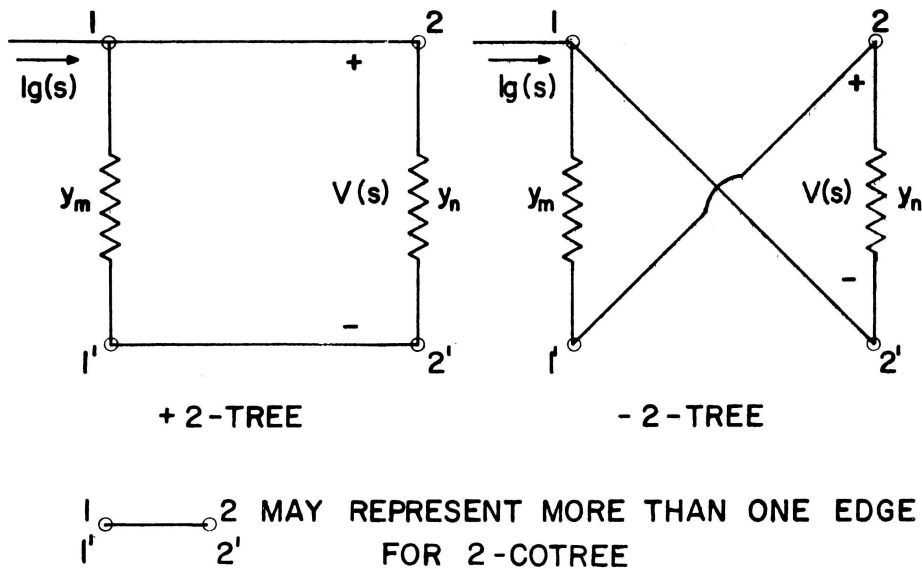

FIGURE 6. REPRESENTATION FOR DETERMINATION OF 2-TREE SIGN

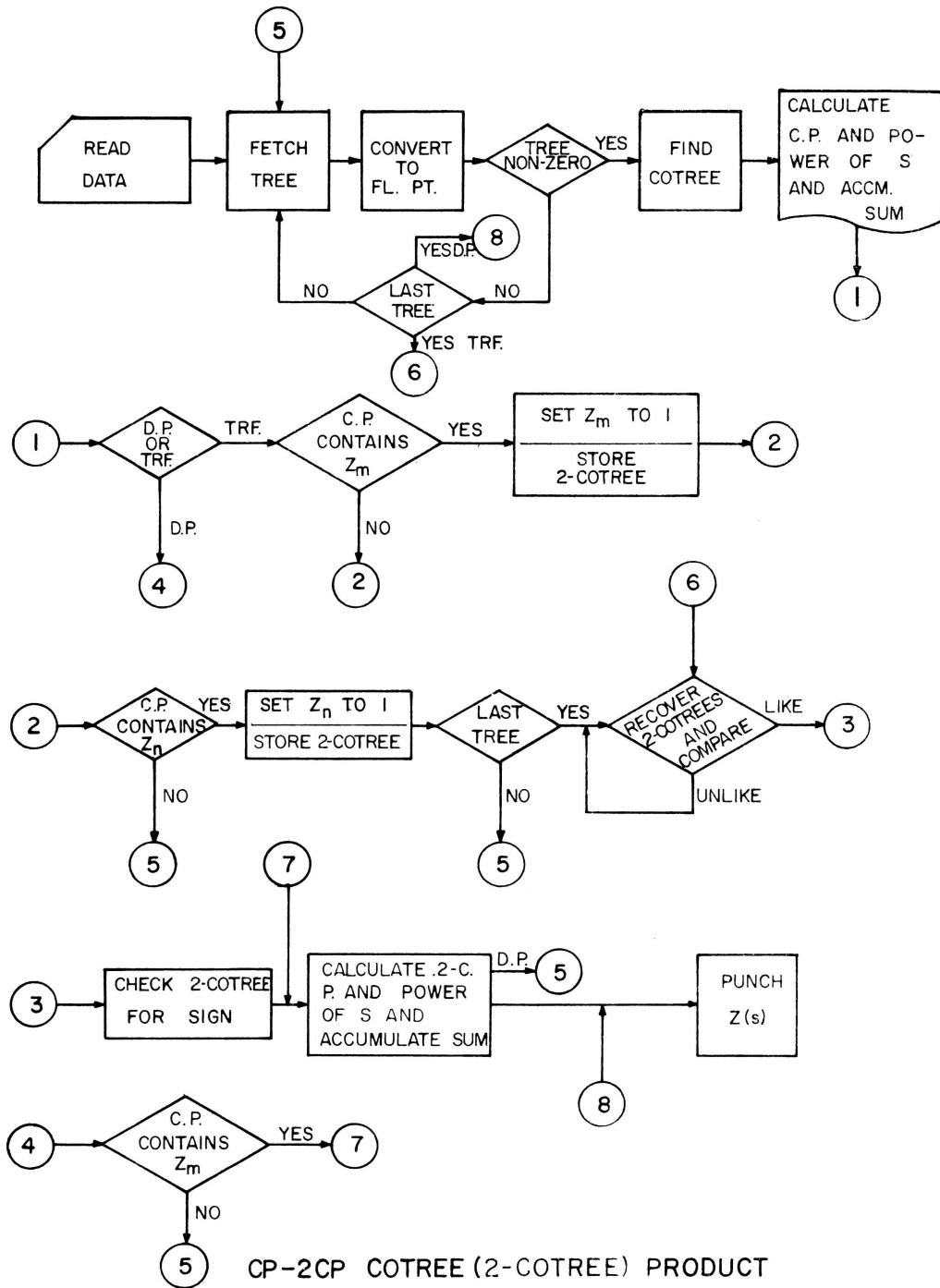
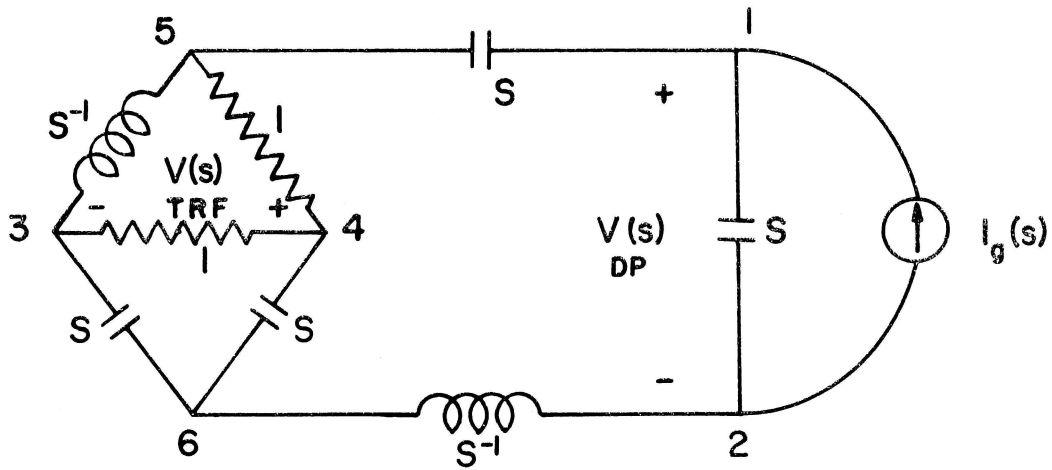
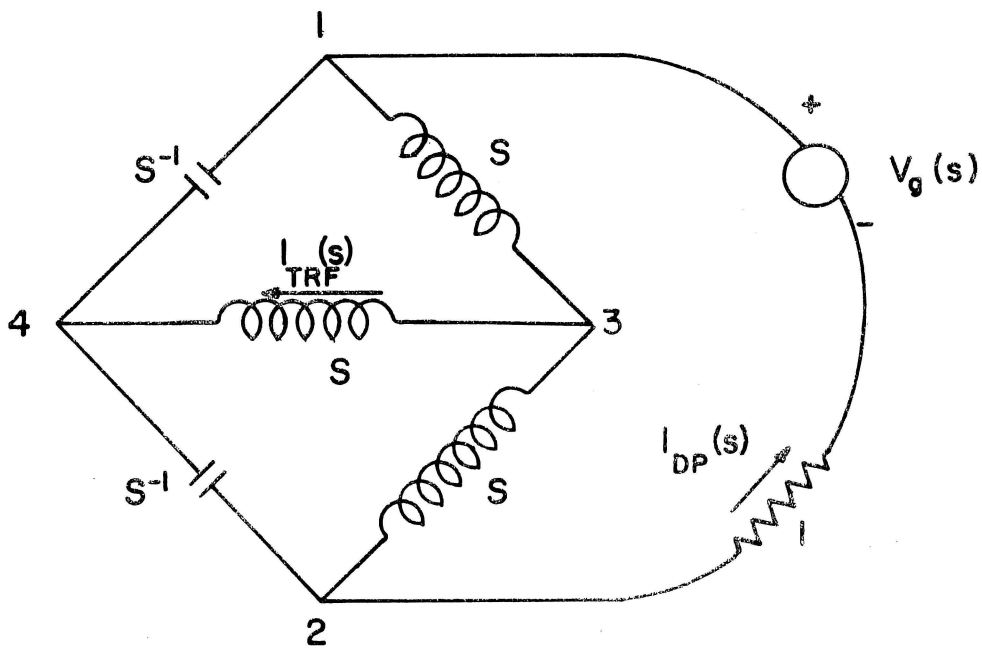

FIGURE 7. SIMPLIFIED FLOW DIAGRAM FOR Z(S) DRIVING POINT AND TRANSFER IMPEDANCE



(A) NETWORK FOR CALCULATION OF  $Y(S)$   
DRIVING POINT AND TRANSFER ADMITTANCES



(B) NETWORK FOR CALCULATION OF  $Z(S)$   
DRIVING POINT AND TRANSFER IMPEDANCES

FIGURE 8. NETWORKS FOR EXAMPLES







## PUBLICATIONS OF THE ENGINEERING BULLETIN SERIES

These publications may be secured from the Director of the Engineering Experiment Station, University of Missouri, Columbia. Single copies may be obtained free unless otherwise indicated until the supply is exhausted. Requests for additional copies will be considered upon further inquiry.

Bulletin  
No.

36. Stresses in a Uniformly Loaded Circular-arc I-Beam, by Robert B. B. Moorman (1947)
37. Thermodynamic Equilibrium Calculations for Combustion Jets, by Ralph Scorah and Jack T. Kimbrell (1950)
38. The Effect of High Temperature Steam on a Nickel-Chromium-Iron Alloy, by Paul Ogden and Ralph Scorah (1952)
40. Selected Papers from the Air and Water Pollution Conference (1956)
41. Pressure Changes at Storm Drain Junctions, by W. M. Sangster, H. W. Wood, E. T. Smerdon, and H. G. Bossy (1958) (\$2.00, tables \$1.00)
44. Bibliography of Factory Layout (1940 through 1958), by Robert M. Eastman, James C. Schloemann, and Roland A. Hill, Jr.
45. Selected Papers from the Air and Water Pollution Conference (1958)
46. Field Testing and Analysis of Two Pre-Stressed Concrete Girders, by Adrain Pauw and John E. Breen (1959)
47. Proceedings of the Fifth Annual Air and Water Pollution Conference, by Ralph H. Lubbers (1959)
48. The Wood Charcoal Industry in the State of Missouri, by J. Pitts Jarvis, Jr. (1960)
49. An Investigation of the Flexural and Shearing Capacity of Reinforced Concrete Beams, by John E. Breen and Adrian Pauw (1960)
50. Proceedings of Conference on Utilization of Scientists and Engineers, by Robert M. Eastman (1960)
51. Selected Papers on Mechanization and Automation in Small Business, by James M. Beauchamp, Jr. (1961)
53. Proceedings of the Sixth Annual Air and Water Pollution Conference, by Ralph H. Luebbbers (1961)
54. Proceedings of the Seventh Annual Air and Water Pollution Conference, by Lindon J. Murphy (1962)
55. Proceedings of the University of Missouri Fourteenth Annual Traffic Engineering Conference (1962)
56. A Review of Literature Pertaining to Creep and Shrinkage of Concrete, by Bernard L. Meyers (1963)
57. Aerobic and Anaerobic Digestion Characteristics of Livestock Wastes, Edgar A. Jeffrey, William C. Blackman, Jr. and Ralph L. Ricketts (1963)
58. Impact Study of a Steel I-Beam Highway Bridge, by James W. Baldwin, Jr. (1964)



University of Missouri Libraries  
University of Missouri

MU Engineering Experiment Station Series

Local Identifier Zobrist1965

Capture information

Date captured 2018 January  
Scanner manufacturer Ricoh  
Scanner model MP C4503  
Scanning software  
Optical resolution 600 dpi  
Color settings Grayscale, 8 bit; Color 24 bit  
File types Tiff

Source information

Format Book  
Content type Text  
Notes Digitized duplicate copy not retained in collection.

Derivatives - Access copy

Compression LZW  
Editing software Adobe Photoshop  
Resolution 600 dpi  
Color Grayscale, 8 bit; Color, 24 bit  
File types Tiffs converted to pdf  
Notes Greyscale pages cropped and canvassed. Noise removed from  
background and text darkened.  
Color pages cropped.