

2. MEASUREMENT TECHNIQUES
(Barczewski, Kobus, Rao)

2.1 Mechanical Probes for Air Concentration Measurements

Experimental research on air-water mixtures depends heavily upon the development of measurement techniques for concentrations and velocities. Therefore, classical methods and recent developments in two-phase flow instrumentation are briefly discussed in this chapter.

The most elementary method of measuring air concentration consists in sucking continuously a sample of air-water mixture from the flow, separating air and water, and measuring their volume rates separately. Using this principle, Delapp [36, 91] developed a mechanical device to measure air concentration. Later, Lakshmana Rao et. al [102] devised a simpler method to measure air concentration in self-aerated open channel flows, which is shown schematically in Fig. 2.1. The method of operation was to make use of the hydraulic gradient present at each point and to suck a sample of air-water mixture through the mechanical probe. As the tip of the probe was free from external fittings which would cause disturbance to the flow, the amount of air collected in a known volume of air-water mixture could be taken as a representative value of the air concentration. A feature of this method is that it can be used to measure air concentration as low as 0.01 % and as high as about 80 %.

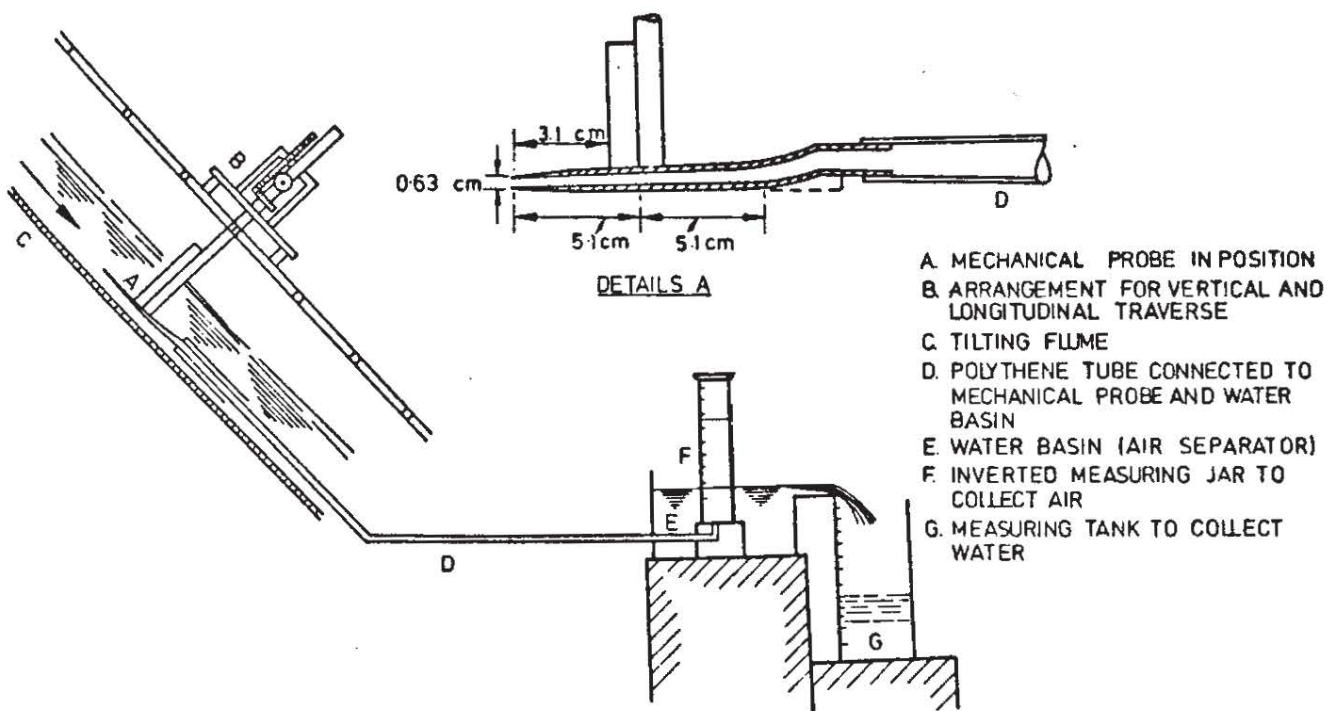

FIG. 2.1 SCHEMATIC SKETCH OF MECHANICAL PROBE FOR AIR CONCENTRATION MEASUREMENT

2.2 Mechanical Probes for Air-Water Velocity Measurements

A simple mechanical method of measuring air-water velocities was suggested by Halbronn [63], which is based on measurements of stagnation pressure by means of a Pitot tube. Gangadharaiah [49] used this concept and developed a more refined instrument.

One difficulty with stagnation pressure measurements in two-phase flows arises from the local disturbance of the flow by the probe, which not only influences the measured pressure value (accounted for by a form-dependent Pitot coefficient Δ), but also changes the local air concentration C . In order to compensate for this effect, a "tapping constant" θ is introduced, which is the ratio of the air concentration at the probe to the concentration value at the same location in absence of the probe ($0 < \theta \leq 1$).

Halbronn's method is based on the plausible assumption that the Bernoulli relationship holds for stagnation pressure measurements in two phase flows, if the density of the mixture is used, whereas the mixture velocity is taken to be equal to the water velocity. Introducing θ as defined above, this yields an equation of the form

$$(1 - \theta C) \frac{\rho_w}{2} u_w^2 = p - p_{\text{static}} \quad (2.1)$$

Using a somewhat different assumption, Gangadharaiah [49] defines the air-water mixture velocity u in terms of the following relationship:

$$\frac{1}{2} \rho u^2 = \Delta (1 - \theta C)^2 (p - p_{\text{static}}) \quad (2.2)$$

Gangadharaiah used a hypodermic needle and a mercury manometer, for which the pressure difference can be expressed in terms of the differential manometer reading H and the density difference ($\rho_m - \rho_w$) between mercury and water. With these substitutions, one obtains

$$u = (1 - \theta C) \left[\Delta \left(\frac{\rho_m - \rho_w}{\rho} \right) 2gH \right]^{1/2} \quad (2.3)$$

With the aid of eq. (1.16),

$$\rho u = (1 - C) \rho_w u_w \quad (2.4)$$

equation (2.2) can be rewritten as

$$\frac{1}{2} (1 - C)^2 u_w^2 = \Delta (1 - \theta C)^2 \left[\left(\frac{\rho_m - \rho_w}{\rho_w} \right) \frac{\rho}{\rho_w} gH \right] \quad (2.5)$$

With the definition for the water discharge

$$Q_w = \int (1 - C) u_w dA \approx \sum (1 - C) u_w dA \quad (2.6)$$

one can deduce from eq. (2.5), by summation over increments δA of cross sectional area up to a height which, say, 99 % of air concentration is found,

$$Q_w = \sum (1 - \theta) \left[\Delta \left(\frac{\rho_m - \rho_w}{\rho_w} \right) \frac{\rho}{\rho_w} 2gH \right]^{1/2} \delta A \quad (2.7)$$

and hence obtains for the "tapping constant" θ the expression

$$\theta = \frac{-Q_w + \sum \left[\Delta \left(\frac{\rho_m - \rho_w}{\rho_w} \right) \frac{\rho}{\rho_w} 2gH \right]^{1/2} \delta A}{\sum C \left[\Delta \left(\frac{\rho_m - \rho_w}{\rho_w} \right) \frac{\rho}{\rho_w} 2gH \right]^{1/2} \delta A} \quad (2.8)$$

This expression allows an evaluation of θ if the air concentration distribution over the cross section is known. Gangadharaiah [49] found an average value of $\theta = 0,74$ for the hypodermic needle he used; the Pitot coefficient Δ was found to be 1.05. With these values, the air-water velocities can now be calculated by eq. (2.3) from the measured manometer readings H and the local air concentration (measured independently).

In order to prevent air from entering the connecting tubes between probe and manometer, Gangadharaiah connected a feeding line by a three-way drain cock, by which water was supplied continuously to the connecting tubes, draining through the probe up to the moment when the measurements were made.

Keller [86, 87] developed a probe for prototype measurements, which measures the stagnation pressure by means of a strain gauged diaphragm (see Fig. 2.2). The practical design of the meter was of critical importance as the diaphragm had to be strong enough to withstand the dynamic shock loading from the highly turbulent flow, yet sensitive enough to respond to small variations in velocity. The diaphragm was made of brass and was designed for a pressure due to a flow velocity of 90 ft./sec. The prototype meter allowed several detachable, different-shaped head sections to be tested; Fig. 2.2 shows the meter which was found to give the most accurate results.

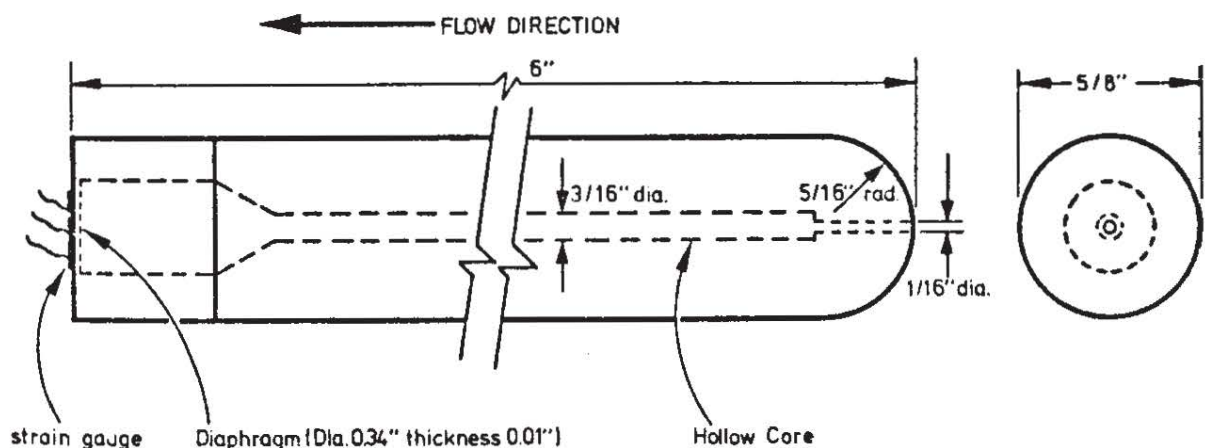

FIG. 2.2 VELOCITY METER [86]

Static calibration of the meter was carried out by measuring the voltage output from the strain gauge at successive increments of accurately controlled pressure and yielded a linear relationship. The dynamic response time of the meter found experimentally was of the order of 1/100 second, which is many times faster than the period of the prototype turbulence fluctuations.

All these velocity measurement probes have in common that they are indirect in the sense that they depend upon simultaneous measurements of air concentration. Therefore, the accuracy of these devices is naturally dependent on the accuracy of the air-concentration probe. Despite this drawback, which results in the compounding of experimental errors, these probes yield satisfactory results. Exhaustive testing of Keller's device showed the velocity meter to be accurate to within 3% over the entire test range of flow conditions.

2.3 Conductivity Probes for Air Concentration Measurements

The basic principle of the electrical method of measurement of air concentration lies in measuring the difference in the electrical conductivity between a mixture of air and water and the conductivity of water alone, since the conductivity of a suspension changes with the concentration of the suspended material.

The conductivity of a suspension of homogenous non-polarizable spheres is given by Maxwell's equation

$$\frac{r - r_1}{2r + r_1} = C \frac{r_2 - r_1}{2r_2 + r_1} \quad (2.9)$$

in which

- r_1, r_2 = the specific resistivity of the suspending liquid and the suspended spheres, respectively
- r = the specific resistivity of the suspension (or the reciprocal of electrical conductivity)
- C = the volume concentration of the suspended material

For non-conducting spheres, as in the case of air bubbles, r_2 tends to infinity, and therefore eq. (2.9) becomes

$$C = \left(\frac{r}{r_1} - 1 \right) / \left(\frac{r}{r_1} + \frac{1}{2} \right) \quad (2.10)$$

If the specific resistivities are taken over the same volume, electrical resistances may be substituted in the ratios of the specific resistivity values.

Based on this principle, an air concentration meter has been devised by Lamb and Killen [105]. The equivalent circuit meter is shown in Fig. 2.3,

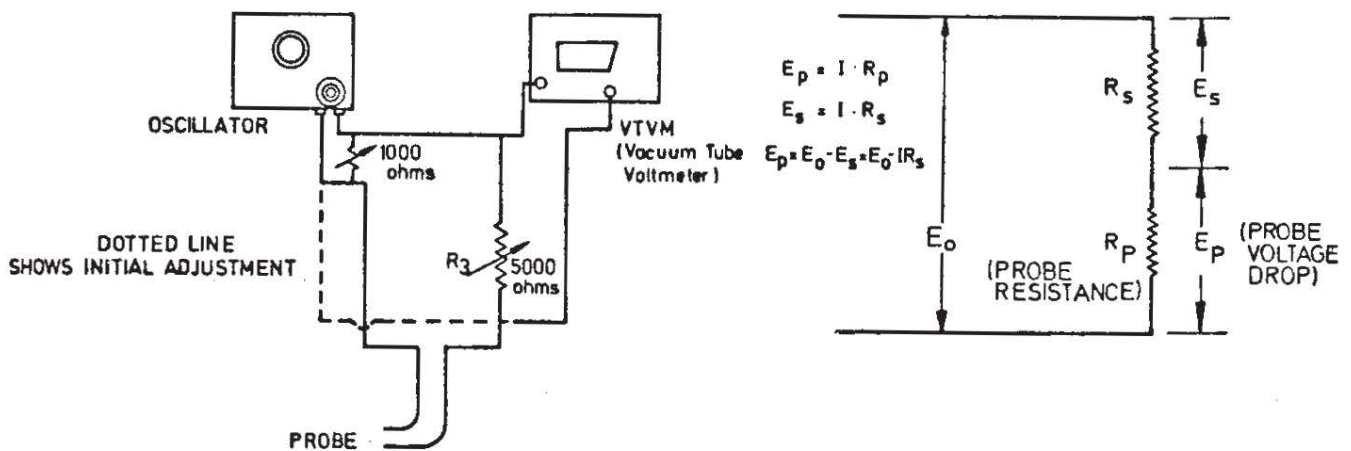

FIG. 2.3 CIRCUIT DIAGRAM FOR THE MEASUREMENT OF MEAN AIR CONCENTRATION IN A FLOWING AIR-WATER MIXTURE

in which E_o is the supply voltage, R_s is an arbitrary series resistance, R_p is the equivalent resistance across the probe, and E_s and E_p are the potential drops across the resistance and the probe, respectively. If one assumes that Maxwell's relationship holds approximately also for bubbles of finite size, the air concentration C is given by rewriting eq. (2.10) in the form:

$$C = \frac{R/R_1 - 1}{R/R_1 + 1/2} \quad (2.11)$$

where R is the electrical resistance of the mixture and R_1 is the electrical resistance of the suspending liquid. Equation (2.11) is the basis for the electrical method of air concentration measurements. With the relationships given in Fig. 2.3, equation (2.11) yields

$$C = \frac{E_o - I (R_s + R_1)}{E_o - I (R_s - R_1/2)} \quad (2.12)$$

If R_s is adjusted such that $R_s = R_1/2$, the air concentration becomes

$$C = 1 - 3 \frac{E_s}{E_o} \quad (2.13)$$

and the water concentration (1-C) is given by

$$(1-C) = 3 \frac{E_s}{E_o} \quad (2.14)$$

From eq. (2.14) it may be seen that the condition ($R_s = R_1/2$) is satisfied if ($E_o/E_s = 3$) when the probe is placed in water which is free from air bubbles. If the voltmeter connected across the resistance is made to read full scale on a 0 to 100 dial, then the reading for any other condition will give directly the concentration or percentage of water present in the air-water mixture. During experiments, it is necessary to check the meter often for full scale reading in water free from air bubbles.

Gangadharaiah [49] and Lakshmana Rao et al. [103] have developed a refined probe shown in Fig. 2.4 which performs well under laboratory conditions. The performance of the probes has to be checked by comparison with measurements by mechanical probes.

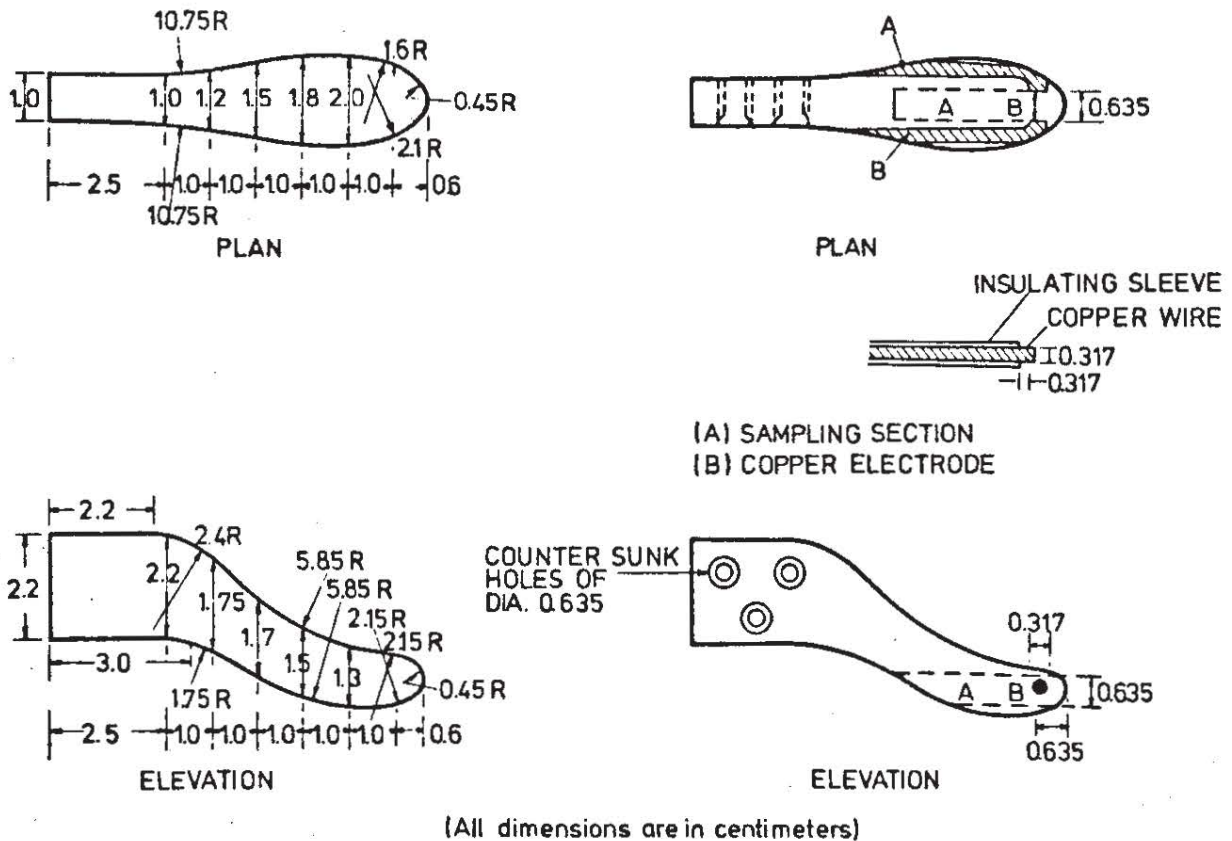

FIG. 2.4 DETAILS OF AIR CONCENTRATION PROBE "I.I. SC. PROBE 4"

Keller [86, 87] has developed a unit for field measurements of air concentration, which is based on the same principle. Because the field test equipment had to incorporate several air concentration probes, the possibility of electrical leakage among them had to be considered. This possibility was eliminated by adopting a co-axial probe design, incorporating a centre spike electrode and an outer earthed cylindrical electrode.

The main consideration in the hydraulic design of the probes were the prevention of separation of the high-speed flow from the conducting surfaces and the optimization of space between the co-axial electrodes. The first problem was overcome by a slight tapering of the centre electrode: the resulting contraction of the flow filament between the electrodes did not cause any significant flow distortion. In deciding the electrode spacing, two contradictory requirements had to be reconciled: the space had to be small enough with respect to the flow depth in order to obtain sufficient vertical resolution, and it had to be large enough to include several bubble diameters in order to avoid full-scale variations of the recording instrument at every bubble passage. The size of the air bubbles in an aerated stream depends on the balance between the turbulence intensity of the flow and the surface energy of the resultant bubbles and is a matter of some conjecture. The dimensions of the prototype probe with an electrode spacing of 1/2 inch are shown in Fig. 2.5. The probe was exhaustively tested over an air concentration range of 0-80 % and a velocity range of 10 - 100 ft/sec and proved to be accurate to within 2 %.

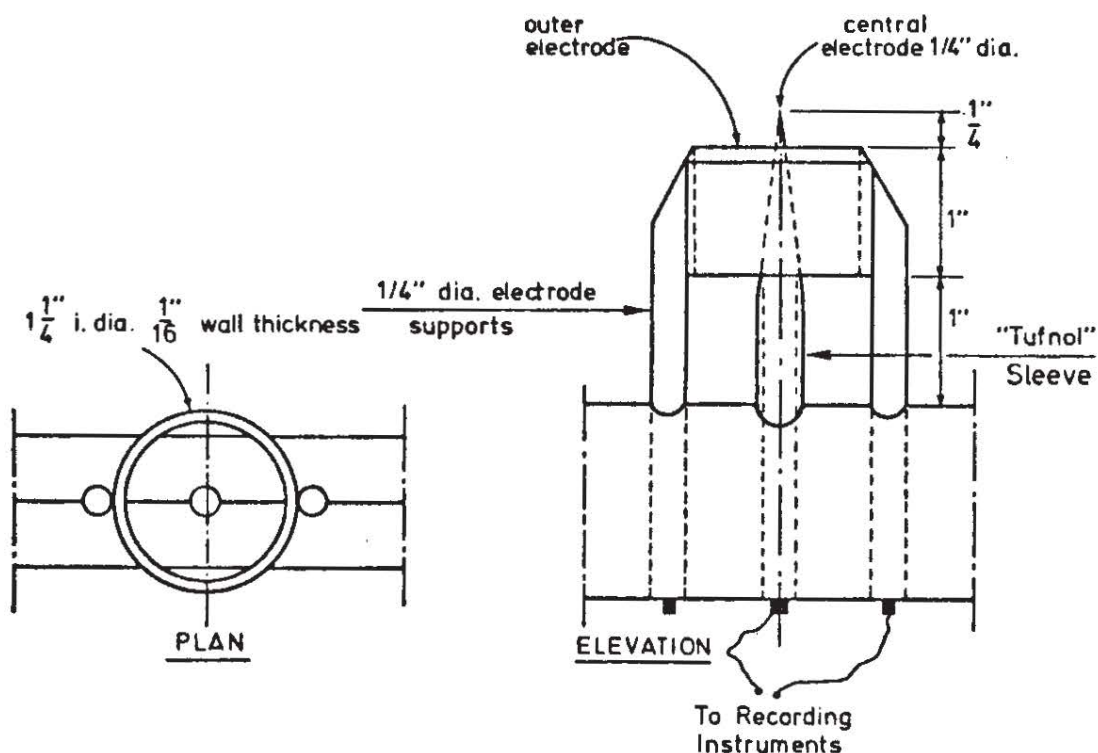

FIG. 2.5 AIR CONCENTRATION PROBE [86]

2.4 Hot Film Technique for Air Concentration and Velocity Measurements

Delhaye [37] made use of the hot-film technique for measurements in air-water flows. The local volume concentration of gas C_a , the mean liquid velocity \bar{u} and the turbulence intensity I can be determined from the period of contact between one phase and the probe (signal duration) and the velocities (signal amplitude). The signals from the hot film probes have been compared to high-speed photographs of the flow, which allowed an interpretation of the anemometer signals in terms of bubble contact with the

probe. The electrical signals $E(t)$ of the probe are converted into digital form and stored and classified by a multichannel analyzer in the form of a histogram $N(E)$ for the signal $E(t)$ (Fig. 2.6). The quantities N_a and N_w from such a histogram yield directly the volume concentration of gas C_a^w to :

$$C_a = \frac{N_a}{N_a + N_w} \quad (2.15)$$

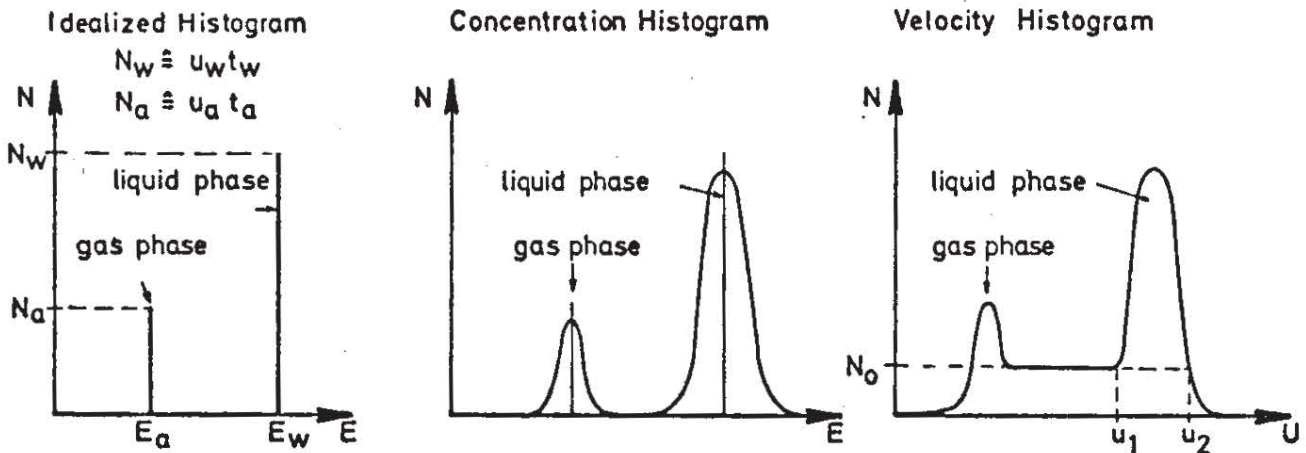

FIG. 2.6 HISTOGRAMS FROM HOT-FILM SIGNALS FOR AIR CONCENTRATION AND VELOCITY MEASUREMENTS

Actually measured histograms differ from the idealized situation, since the hot film probes are not free of inertial effects and have a finite time constant. The observed histograms as sketched in Figure 2.6 still yield the gas concentration, if now the respective areas under the peaks are used in eq. (2.15). Correspondingly the mean liquid velocity \bar{u}_w and the turbulence intensity I can be determined from the velocity histogram (Fig. 2.6) as

$$\bar{u}_w = \frac{\sum_{u_1}^{u_2} u_{wi} (N_i - N_0)}{\sum_{u_1}^{u_2} (N_i - N_0)} \quad (2.16)$$

and

$$I = \frac{\overline{u_w'^2}}{\bar{u}_w^2} = \frac{\sum_{u_1}^{u_2} \left(\frac{u_{wi}}{\bar{u}_w} - 1 \right)^2 (N_i - N_0)}{\sum_{u_1}^{u_2} (N_i - N_0)} \quad (2.17)$$

Delhaye [37] gives a thorough discussion of the possibilities of the method, as well as criteria for selecting suitable probe shapes and sizes and an estimate of the time constant of the probes. He compared his results with concentration measurements by gamma radiation absorption, which yielded satisfactory agreement. However, the technique is limited by the dimensions of the bubbles and the flow velocity. This is why it has proved to be unusable in the case of emulsions where the diameters of the bubbles have an order of magnitude of 0.1 mm while the velocities reach 30 to 50 m/s.

Further advances have since been made in the use of the hot-film technique for measurement of turbulent quantities in liquid flows. Resch [143] and Resch and Leutheusser [144] have used the hot-film technique for turbulence measurements in water flow. Leutheusser, Resch and Alemu [109] have measured Reynolds stresses and determined the flow properties of various hydraulic jumps created in a horizontal flume with the aid of hot-film anemometry using conical probes. More recently, Resch, Leutheusser and Alemu [146] have determined the void ratio and size characteristics of air bubbles entrained into jumps.

2.5 Optical Methods for Air Concentration Measurements

Mechanical and conductivity methods for air concentration measurements are useful only if the air bubbles are small compared with the size of the probe, or if there is at least no large variation in bubble diameters. In many applications, these conditions are not met and frequently air bubbles ranging in diameter from 1 mm to 50-70 mm appear simultaneously. Accurate measurements require therefore the development of a new method for determining the mean air concentration in air-water mixtures.

Theoretical considerations lead to optical methods which in chemistry are normally used for tracer concentration measurements. The basis of all optical concentration measurements is the attenuation of a known light flux passing the test section by the tracer substance. The attenuation of light in the test section can be caused by absorption, reflection, or scattering. For a given tracer substance, the absorption is dependent on the wavelength of the light used.

After elimination of the losses by reflection, refraction or scattering the light attenuation by pure absorption (that is for a tracer substance in a non absorbing medium) is given by the Bouguer-Lambert-Beer law. For the absorption of monochromatic parallel light in diluted solutions, this yields

$$\phi = \phi_0 \cdot 10^{-\epsilon_{\lambda} \cdot C \cdot d} \quad \therefore \lg(\phi / \phi_0) = -\epsilon_{\lambda} \cdot C \cdot d \quad (2.18)$$

or

$$C = -\frac{1}{\epsilon_{\lambda} d} \lg \left(\frac{\phi}{\phi_0} \right) \quad (2.19)$$

where

ϕ_0, ϕ = light flux entering and leaving the test section, respectively

ϵ_λ = extinction coefficient (material constant, depending on the wavelength used)

C = concentration of the tracer substance

d = thickness of the test section

The losses by refraction or scattering can be eliminated in two different ways. If a second light beam with the same intensity is sent through a second, identical test section without tracer substance (double beam measurement), then the light flux ϕ' of this second beam can be considered as reference for the absorption measurement, because it will only be attenuated by reflection and scattering. Another method is to send two light beams of equal intensities, but different wavelengths λ_1 and λ_2 through the same test section. The reduction of light flux by reflection, scattering and refraction will be equal for both wavelengths. If only λ_1 is absorbed by the tracer substance and not λ_2 , then the light flux ϕ_2 after passing the test section can be used as the adjusted reference light flux.

In order to test whether the principle of extinction (that is light attenuation) measurement can be used for concentration measurements in air-water mixtures or in two-phase flows in general, a set of preliminary investigations has been carried out by Barczewski. The essential question was to check whether in the statistical average the macroscopic light attenuation by bubbles, drops or particles, which act as lenses (and reflect, refract, scatter and absorb) follows a law which is equivalent to the Bouguer-Lambert-Beer law, which itself is strictly valid only for microscopic light attenuation.

In a simple calibration unit as sketched in Fig. 2.7, the light attenuation was measured as a function of the volume concentration of air bubbles in water. A parallel light beam (diameter about 1 cm) from a mercury vapor pressure lamp was focused after passing the test section on a photomultiplier, whose signals were averaged over 100 to 1000 s. The test section consisted of a rectangular lucite section of thickness $d = 12.5$ cm with a bottom of porous glass (pore size about 1/100 mm). The average volume concentration of air bubbles was calculated from the difference of water surface levels ($h - h_0$) with and without air bubbles; the average volume concentration in percent was then $c = (h - h_0)/h \cdot 100$. The results from this simplified arrangement are given in Fig. 2.8 and show a good correspondence with the expected exponential law for air concentrations from 1 to 18 %.

The optical measurement technique described here is restricted to two-dimensional measurement and subject to the condition that the diameter of the light beam should be bigger than the diameter of the largest bubbles. Also, the electronics put a limitation upon the maximum detectable volume concentration of air bubbles for a given test section size: e.g. at a thickness of $d = 12.5$ cm and an air concentration of 30 %, the absorption ratio is 10^{-5} .

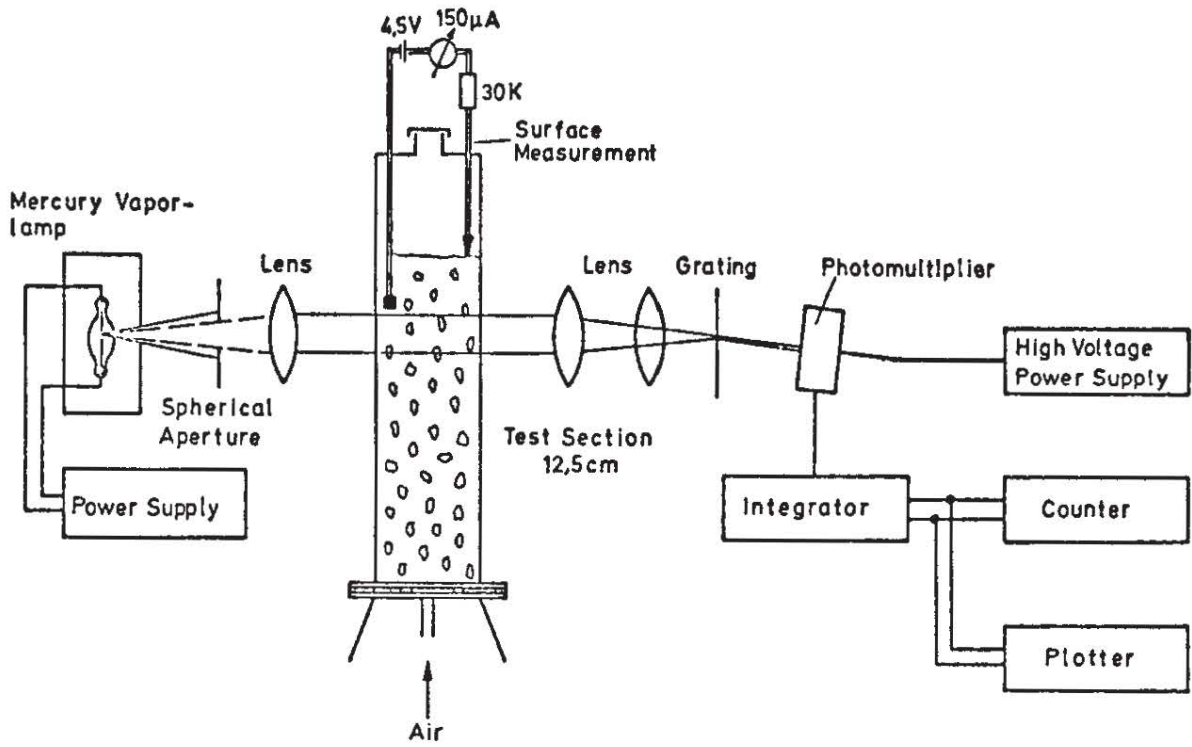

FIG. 2.7 TEST SETUP FOR OPTICAL MEASUREMENT OF AIR CONCENTRATION IN AIR-WATER MIXTURES (TRANSMISSION METHOD)

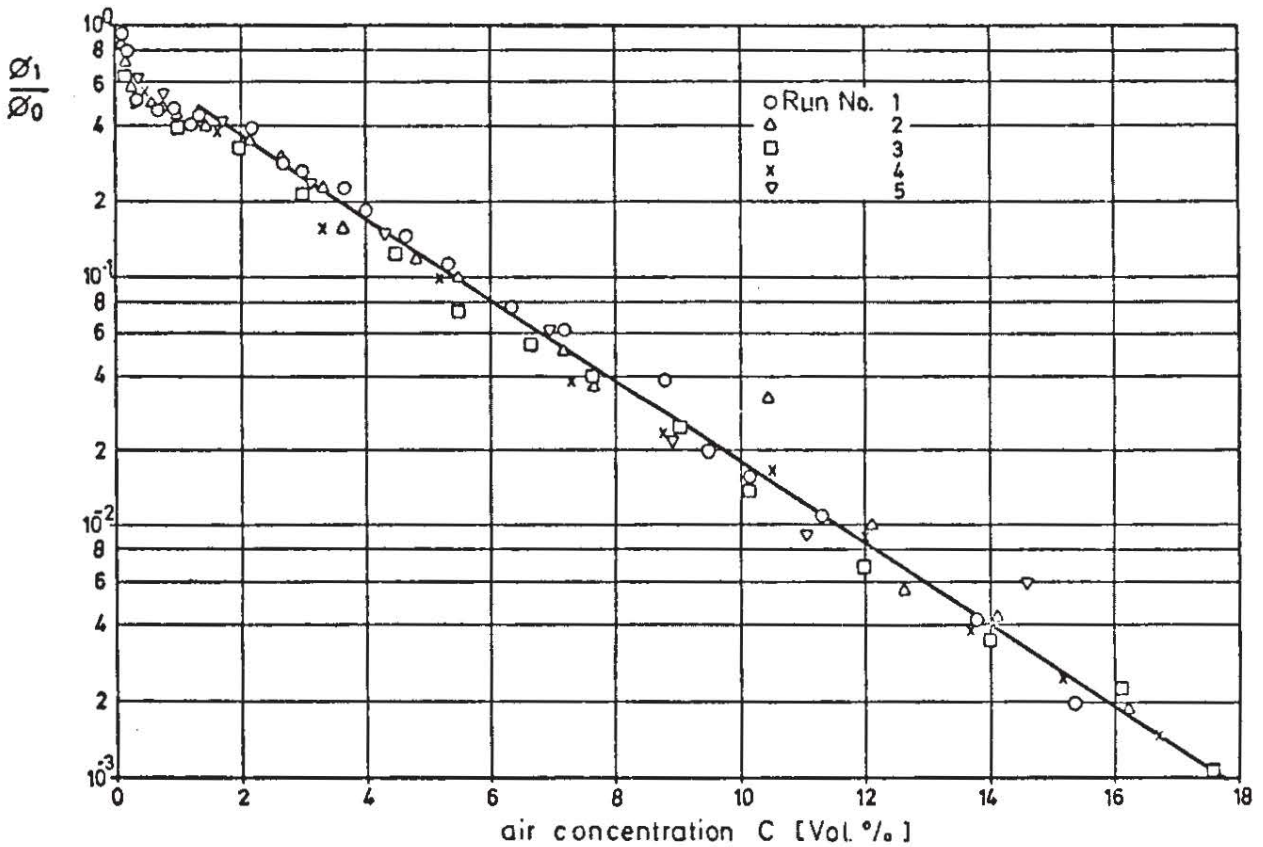

FIG. 2.8 CALIBRATION CURVE FOR OPTICAL CONCENTRATION MEASUREMENT

Measurements in channels and reservoirs which do not allow transmission of light can be performed with a modified test set-up as shown in Fig. 2.9.

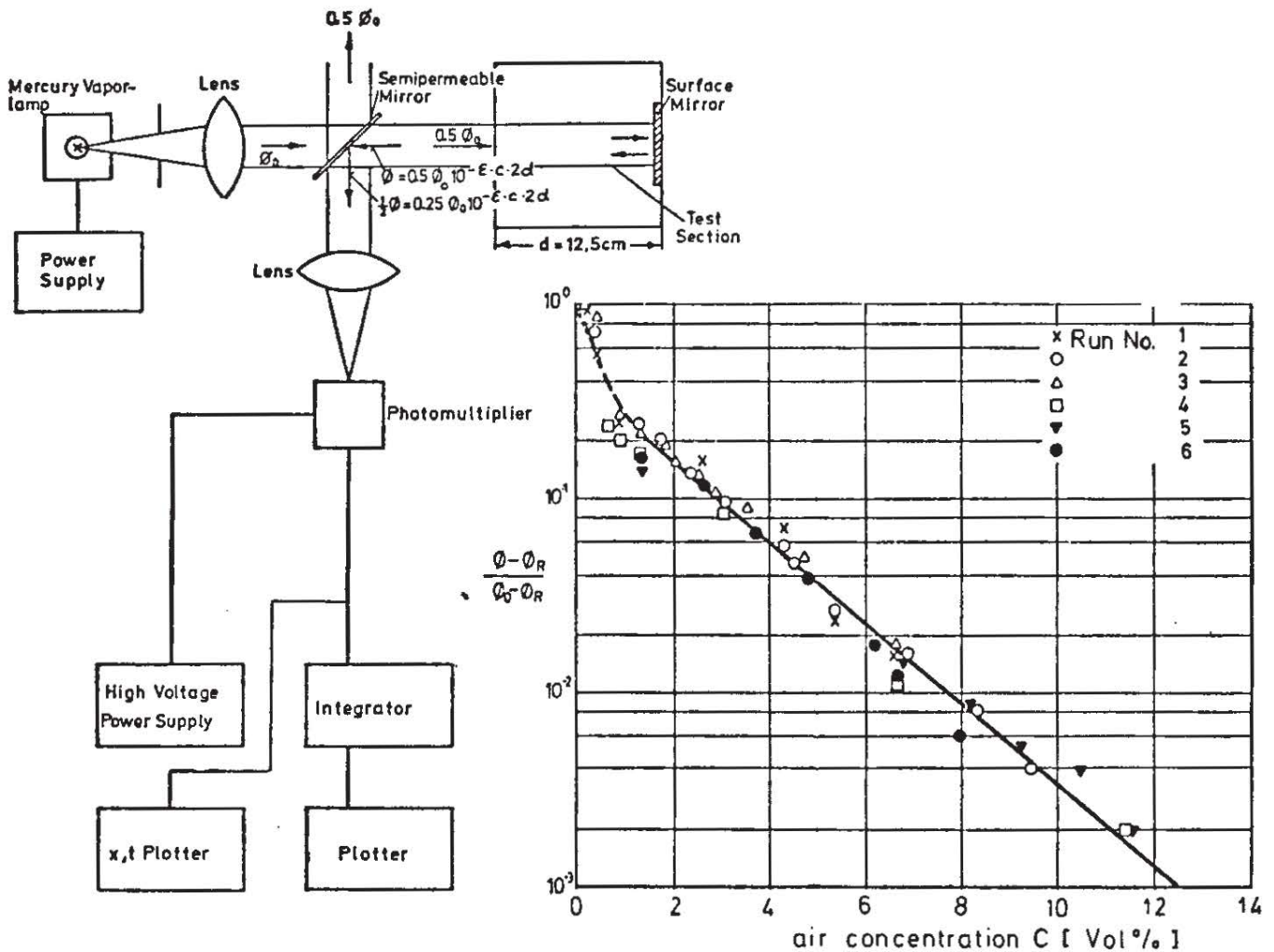

FIG. 2.9 OPTICAL MEASUREMENT OF AIR CONCENTRATION BY THE REFLECTION METHOD

In this case the light beam is divided by a semi-permeable mirror. One of these two beams (light flux $\frac{1}{2} \phi_0$) passes the test section and is reflected by a mirror at the opposite side of the test section. The reflected light beam passes the test section again and then reaches the permeable mirror, where half of the light flux is reflected to a photomultiplier. This method is more complicated than the transmission method, but here also an exponential law was found for concentrations from 1 % up to about 12 %, as can be seen in Fig. 2.9.

2.6 Measurement of Water Surface Elevations

Killen [91] devised an instrument to measure the water surface elevation of air-water mixtures. It consists of a small electrical probe mounted on a traversing mechanism above the water surface so that the tip can be accurately positioned at any depth above the channel bottom. A constant electrical current source is connected to this probe, so that a predetermined

electrical current flows whenever the probe is immersed, and the current drops to zero when the probe is located above the water surface. This gives a square wave of electrical current as sketched in Fig. 2.10. A block diagram of the electrical circuit is also shown in this figure.

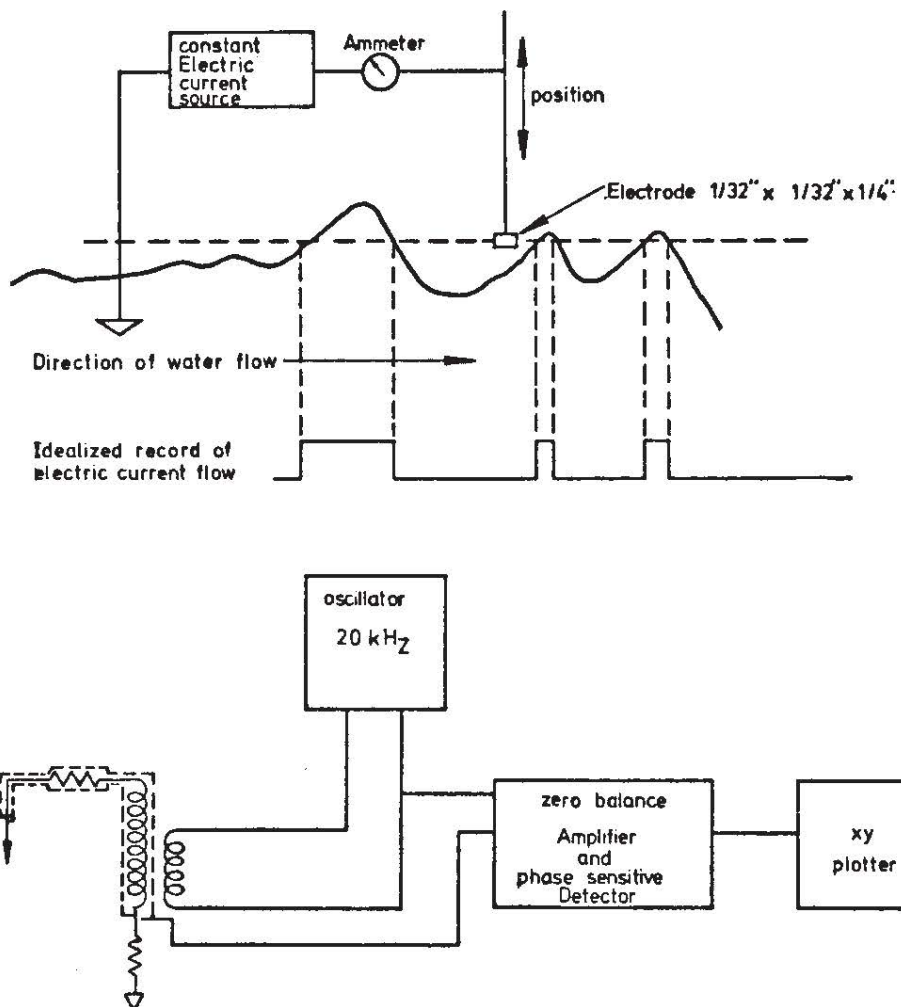

FIG. 2.10 INSTRUMENT FOR MEASUREMENT OF WATER SURFACE HEIGHT DISTRIBUTION [91]

2.7 Measurement of Air Discharge

In his investigations on air-entrainment due to a two-dimensional jet impinging on a wall, Renner [142] has used a technique to measure air discharges without affecting pressure conditions. Figure 2.11 shows his experimental set-up. The air discharge, Q_a , was measured directly at the air inlet to the enclosed test section by means of standard nozzles. The pressures p_v upstream from the nozzle and p_i at the test section were detected by pressure cells, amplified and recorded. The air-flow rate, provided by a compressor system, could be controlled by a needle valve and a bypass valve. The system was adjusted in such a way that the overpressure p_v in the plenum chamber compensated for the pressure drop across the nozzle and in the supply line. Consequently, the air pressure, p_i in the test section could be maintained constant and independent of the flow rate.

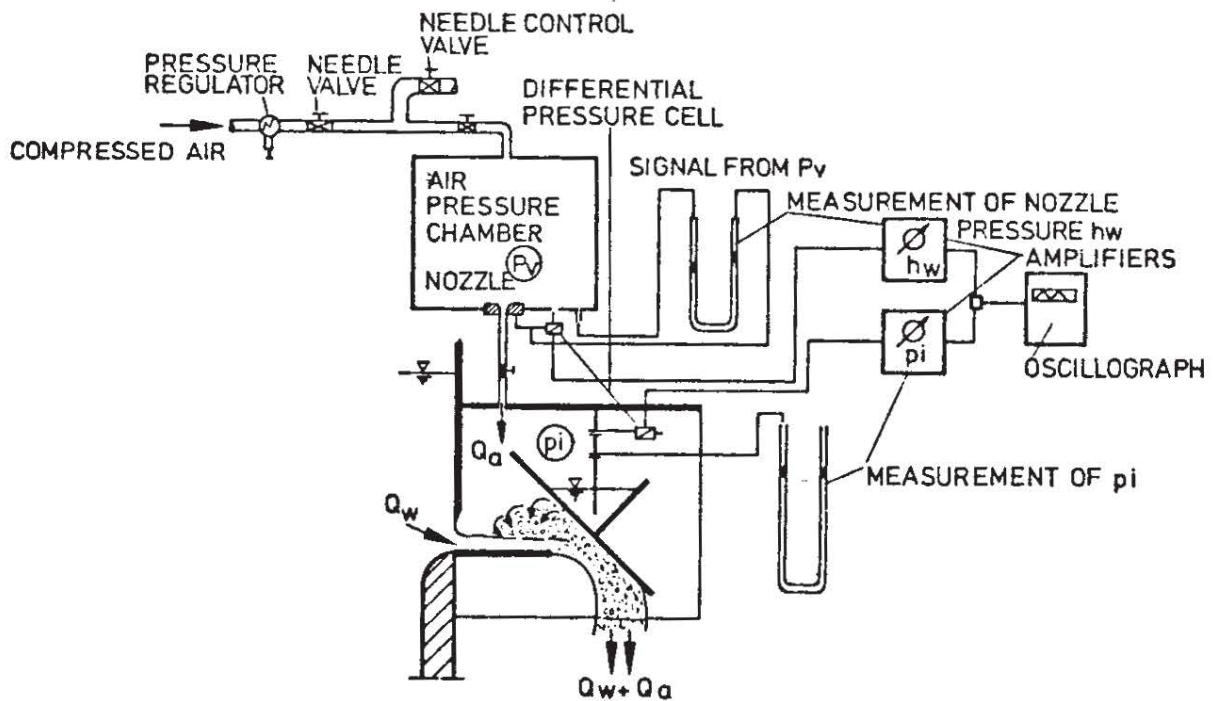

FIG. 2.11 RENNER'S EXPERIMENTAL SETUP FOR MEASUREMENT OF AIR DISCHARGE

2.8 Field Test Units

In what may be regarded as a pioneering effort, Keller 86,87 has developed instrumentation for measuring air concentrations and velocities in prototype structures and used them for field investigations on the gated spillway of the Aviemore dam across the Waitaki river in New Zealand. His field test unit consisted basically of two piers mounted side by side, [12] inches apart, on a single base plate. One pier incorporated the air concentration probes and the other the velocity meters. Making the reasonable assumption that the average air concentration at the velocity meter was the same as the measured air concentration at the same height on the air concentration pier, velocity values were calculated from the time average stagnation pressure readings. It was thus assumed that the flow was two-dimensional over the width of the field test unit. Each pier was 2 feet high and made from 6 x 3 inch hollow steel sections. The piers were fitted with streamlined nose cones made from "Tufnol", - a mechanically strong, easily worked material with excellent insulation properties (necessary to prevent stray electrical leakage between probes). Figure 2.12 shows an isometric view of the field test unit.

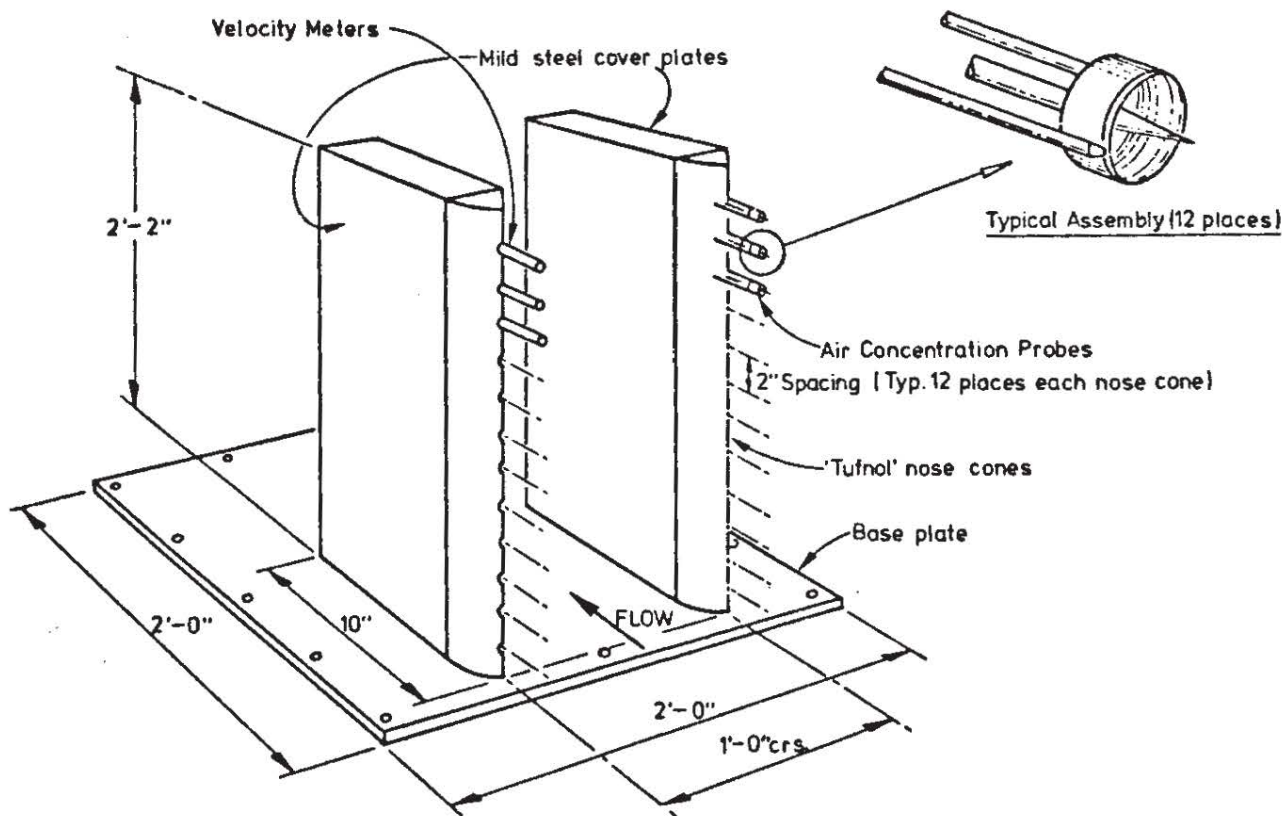

FIG. 2.12 AVIEMORE SPILLWAY FIELD TEST UNIT [86]

The field measurements were conducted with the aid of a remote sampling system, by which the output from each probe was sampled in turn (for a particular station on the spillway). The disadvantage of the system was that it was not possible to record from each probe simultaneously. However, with this configuration, only one processing unit for each flow parameter was required at the test site, and only one screened output wire required to transfer the signals to the recording station. The remote switching was

achieved by incorporating three switch control wires in the system. By using three switching states (+, 0, -) on each wire and assigning a unique combination of states to each probe, it was possible to sample to a maximum of 27 switch positions. A matrix of reed relays was used at the switching system, controlled directly by signals from the recording station.

Figure 2.13 shows a block diagram of the overall instrumentation system and gives details of the air concentration and velocity pier electronics.

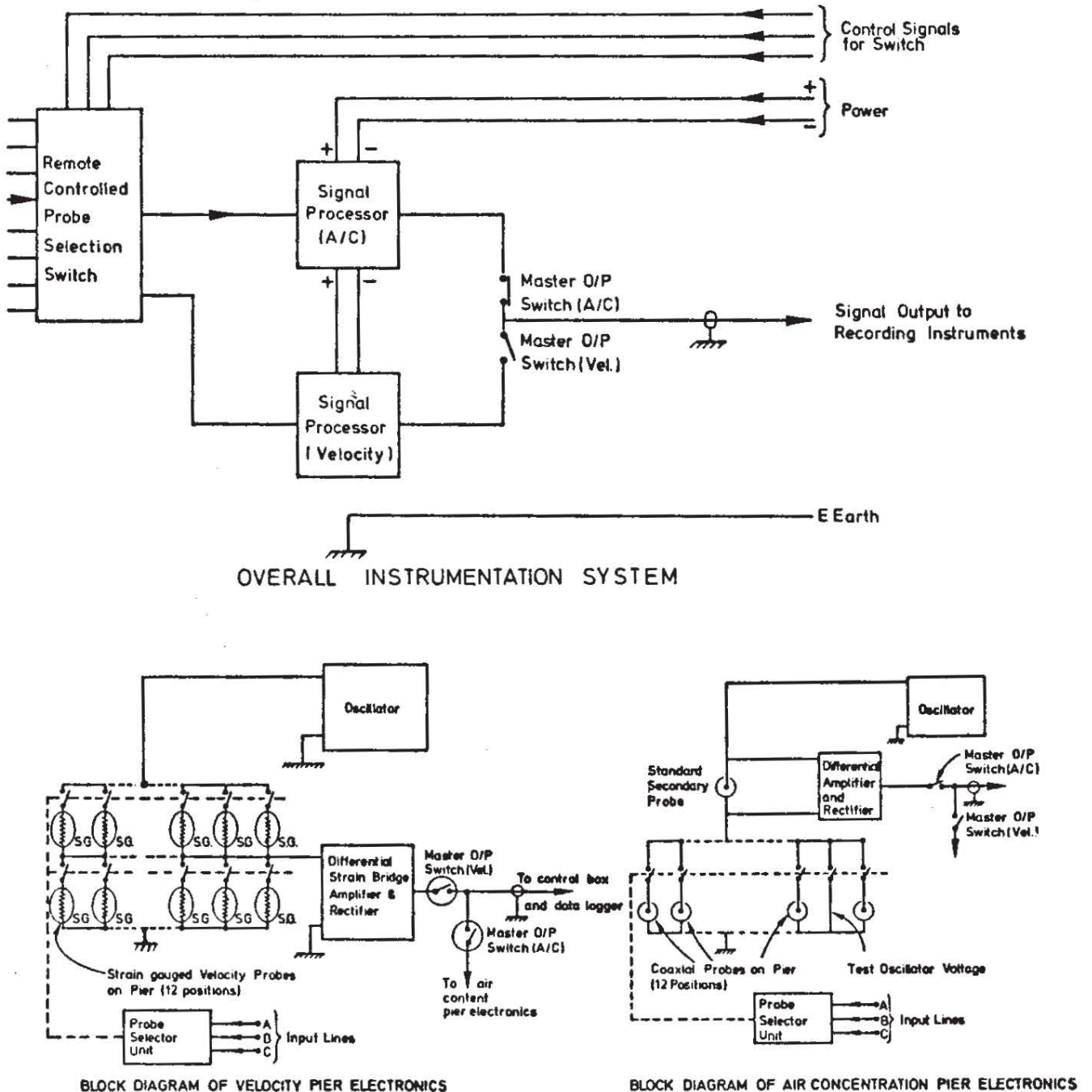

FIG. 2.13 BLOCK DIAGRAM OF FIELD TEST UNIT INSTRUMENTATION SYSTEM [86]

To overcome the restriction that the flow should be two-dimensional, Keller [87] proposes a composite air concentration-stagnation pressure meter. Such an instrument would enable measurements to be made near a spillway side wall, where the extent of air-induced bulking may be the criterion for spillway design [86]. Figure 2.14 shows a meter which would satisfy this requirement. The critical factor in the design of the meter is the minimum gap size possible for the air concentration measurements. The important consideration concerns the size of the air bubbles which could be investigated by photographing full-scale flows using a high speed or stroboscopic camera.

Note: Holding struts for external electrode omitted for clarity.
All dimensions are provisional.

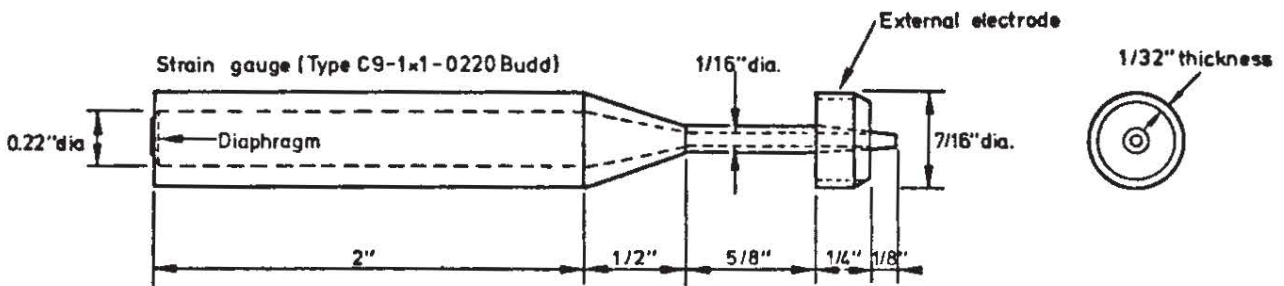

FIG. 2.14 PROPOSED DESIGN FOR COMPOSITE AIR CONCENTRATION-VELOCITY METER [86]