

# Short-Circuit Protection for an IGBT with Detecting the Gate Voltage and Gate Charge

著者	Hasegawa K., Yamamoto K., Yoshida H., Hamada K., Tsukuda M., Omura I.
journal or publication title	Microelectronics reliability
volume	54
number	9-10
page range	1897-1900
year	2014-08-10
URL	<a href="http://hdl.handle.net/10228/00006291">http://hdl.handle.net/10228/00006291</a>

doi: info:doi/10.1016/j.microrel.2014.07.083

# Short-circuit protection for an IGBT with detecting the gate voltage and gate charge

K. Hasegawa<sup>a,\*</sup>, K. Yamamoto<sup>b</sup>, H. Yoshida<sup>b</sup>, K. Hamada<sup>b</sup>,  
M. Tsukuda<sup>c</sup>, I. Omura<sup>b</sup>

<sup>a</sup> *Department of Biological Functions and Engineering, Kyushu Institute of Technology,  
2-4, Hibikino, Wakamatsu-ku, Kitakyushu, Fukuoka, 808-0196, Japan*

<sup>b</sup> *Department of Electrical Engineering and Electronics, Kyushu Institute of Technology,  
1-1, Sensuicho, Tobata-ku, Kitakyushu, Fukuoka, 804-8550, Japan*

<sup>c</sup> *The International Centre for the Study of East Asian Development (ICSEAD),  
1-8, Hibikino, Wakamatsu-ku, Kitakyushu, Fukuoka, 808-0196, Japan*

---

## Abstract

This paper proposes a new short-circuit protection method for an IGBT. The proposed method is characterized by detecting not only gate charge but also gate voltage of the IGBT. This results in a shorter protection time, compared to the previous method that detects only the gate charge. A real-time monitoring system using an FPGA, A/D converters, and a D/A converter is used for the proposed protection method. Experimental results verify that the proposed method achieves a protection time of 390 ns, which is reduced by 68% compared to the previous method.

---

## 1. Introduction

In recent years, current density of insulated-gate bipolar transistors (IGBTs) is getting higher as their market share grows [1-3]. One of the key issues in reliability of IGBTs is protection from a short circuit in the inverter [2-8]. The higher current density results in higher heat density in the IGBTs, so that temperature rising gets faster in the short-circuit condition.

This paper proposes a new short-circuit protection method with sensing the gate charge and gate voltage of the IGBT using a digitally-controlled real-time monitoring system. The method is characterized by putting a short-circuit detection curve to the characteristic of the gate charge vs. gate voltage of an IGBT. This results in a significantly short protection time of 390 ns for a 600-V 10-A IGBT.

## 2. Short-circuit protection for IGBTs

### 2.1 Protection method with detecting the collector current or collector-emitter voltage

Many kinds of protection method based on the collector current or collector-emitter voltage sensing has been proposed [4, 5]. They detect overcurrent at

the collector or de-saturation collector-emitter voltage. They need additional hardware installation to the IGBT, which brings higher initial cost.

IGBT modules having short-circuit protection have been used, which employ a current-sense emitter to detect the collector current [6, 7]. This method, however, has a delay time of 5  $\mu$ sec for sensing the collector current because a low-pass filter is embedded in the module to filter noise components.

### 2.2 Protection method with detecting the gate charge

The authors have addressed a short-circuit protection method with gate-charge sensing [2, 3], namely, previous method. In the normal condition,  $Q_G$  rapidly increases when  $V_{GE}$  exceeds its threshold voltage because  $V_{TH}$  a miller current flows into the collector terminal. On the other hand,  $Q_G$  in the short circuit condition is lower than that in the normal condition because the miller current does not flow. The previous method detects the short circuit by comparing the gate charge after the gate voltage rises to its maximum voltage of 15 V. However, the IGBT starts to turn on when the gate voltage exceeds its threshold voltage, i.e., the previous method

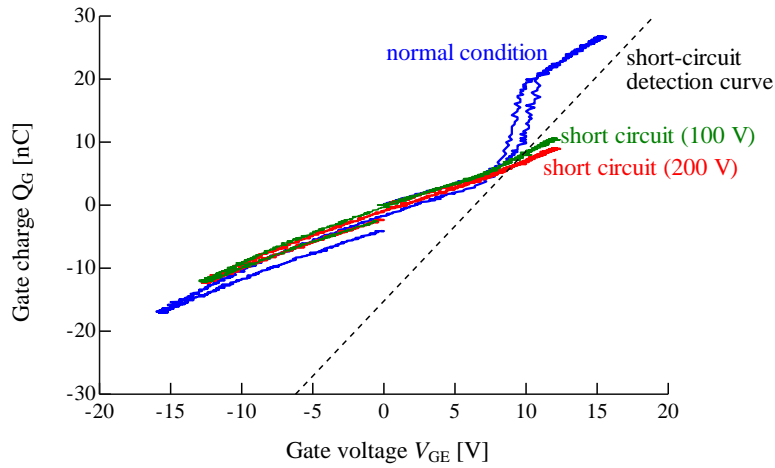

Fig. 2. Characteristic of the gate charge  $Q_G$  vs. gate voltage  $V_{GE}$  in experiment.

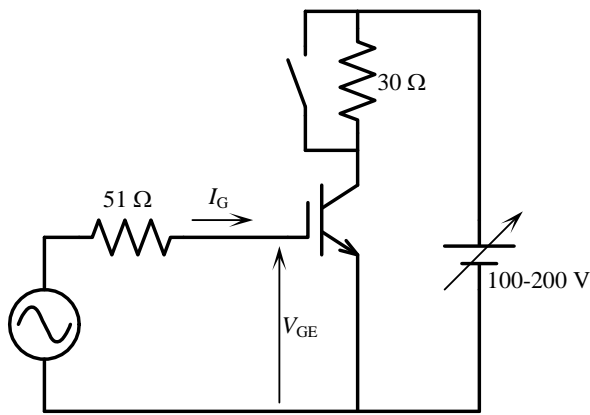

Fig. 1. Measurement for characteristics of the gate charge  $Q_G$  vs. gate voltage  $V_{GE}$ .

inherently contains a delay time to turn off the IGBT.

### 3. Proposed method

#### 3.1 Characteristic of gate charge vs. gate voltage

This paper describes characteristics of gate charge vs. gate voltage because it is indispensable to implement the proposed method as described in the next subsection.

Fig. 1 shows the measurement circuit for the characteristic. An IGBT of GT10J303 (Toshiba Corp.) is employed, which is rated at 600 V and 10 A. An ac voltage source is connected between the gate and the emitter through a gate resistor of 51  $\Omega$ . A resistor of 30  $\Omega$  is connected between the collector and the dc voltage source when the characteristic under normal condition is measured, whereas the

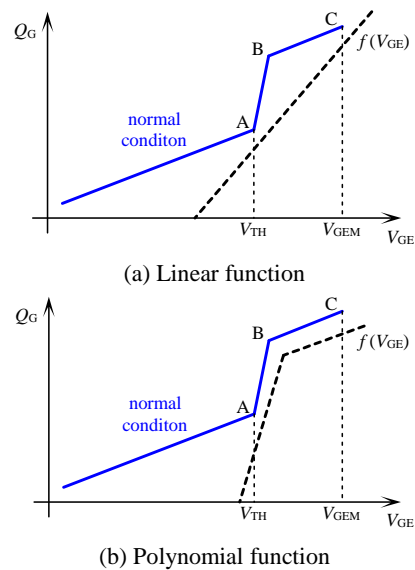

Fig. 3. Basic ideas for putting the detection curve  $f(V_{GE})$ .

collector is directly connected to the dc voltage source when that under the short-circuit condition is done. The dc voltage is adjusted to 100-200 V.

Fig. 2 shows measured characteristics under the normal condition and short-circuit condition. The gate charge of the normal condition was larger than that of the short-circuit condition in a range of  $V_{GE} > 8$  V that is the threshold voltage of the IGBT. The characteristics of short-circuit condition slightly depended on collector-emitter voltage[9].

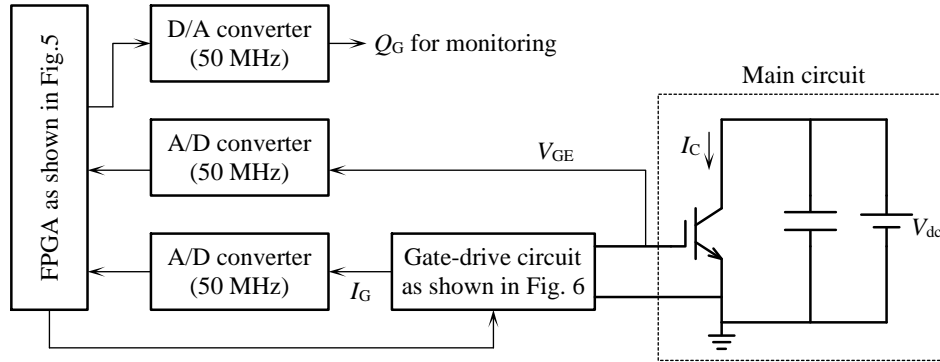

Fig. 4. Experimental system.

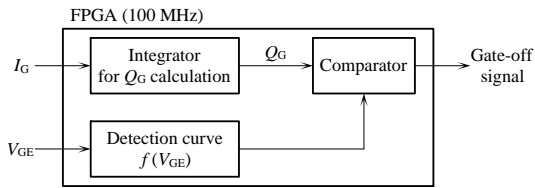

Fig. 5. Block scheme of FPGA.

### 3.2 Short-circuit protection with detecting the gate voltage and gate charge

This paper introduces a short-circuit detection curve  $f(V_{GE})$  to the characteristic. This method can detect the short circuit before  $V_{GE}$  reaches 15 V, so that it achieves a shorter protection time compared to the previous method.

This paper puts the detection curve  $f(V_{GE})$  as a linear function on the measured characteristics shown in Fig. 2 as follows:

$$f(V_{GE}) = 2.4V_{GE} - 15.2 \quad (1)$$

An intersection point of short circuit curves and the detection curve appears before  $V_{GE}$  reaches the maximum value of 15 V. Hence the method catches a short circuit with a quite short protection time in case the IGBT is going to turn on.

The proposed method does not produce any effect to pulse-width-modulation (PWM) for converters in the normal condition, so that it has no constraint to switching frequency. Note that the proposed method requires a real-time monitoring for the gate voltage as well as the gate charge.

### 3.3 How to put the detection curve

The detection curve comes from the measured characteristic of  $Q_G$  vs.  $V_{GE}$  in the normal condition, so that it requires experimental measurement for each IGBT. Fig. 3 illustrates basic ideas for putting the detection curve. It can be put on as a liner

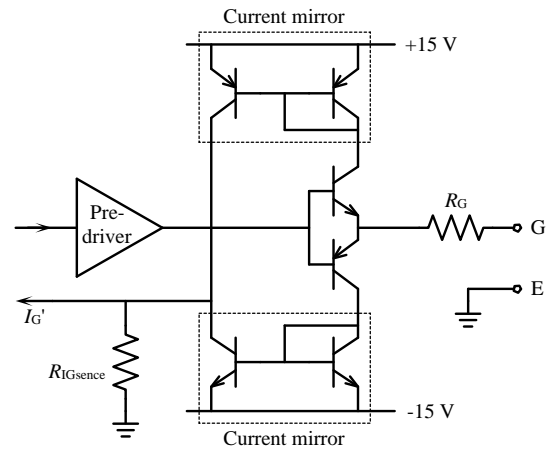

Fig. 6. Gate-drive circuit with current mirrors for measurement of the gate current.

function or a polynomial function. The linear function should keep slightly on the right side of the point A ( $V_{GE}$  reaches threshold voltage  $V_{TH}$ ), and that of the point C ( $V_{GE}$  reaches maximum voltage  $V_{GEM}$ ). The polynomial function should keep slightly on the right side of the points B where the miller effect ends as well as the points A and B. Note that a margin between the normal condition curve and the detection curve should be determined with considering the influence of temperature related effects such as a decrease of  $V_{TH}$ .

## 4. Experimental System

### 4.1 Experimental circuit and real-time monitoring system

Fig. 4 shows the experimental system including the main circuit and real-time monitoring system. The IGBT (GT10J303) is directly connected to a dc

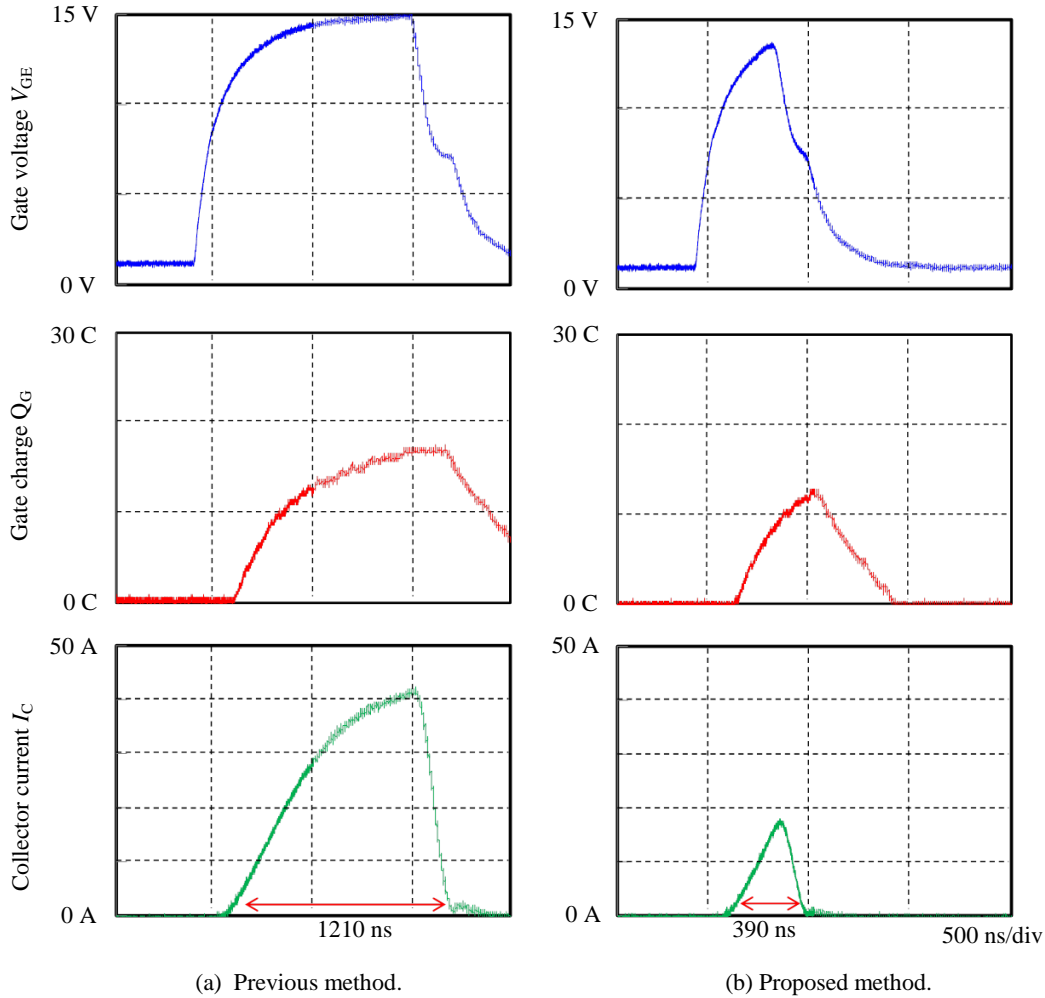

Fig. 7. Experimental waveforms under the short circuit condition.

voltage source of 100 V.

The real-time monitoring system consists of a field programmable gate array (FPGA), analogue-to-digital (A/D) converters, and a digital-to-analogue (D/A) converter. The D/A converter is used for monitoring the gate charge  $Q_G$ . Table 1 summarizes the devices used in the real-time monitoring system. Fig. 5 shows the block scheme of implementation in the FPGA. It calculates the gate charge  $Q_G$  by means of integrating the gate current  $I_G$ , and decide the gate-off signal.

#### 4.2 Gate charge detection in a gate-drive circuit

Fig. 6 shows the gate drive circuit equipped with two current-mirror circuit. The current-mirror circuits are intended for sensing the gate current, so

Table 1 Devices used in the monitoring system

FPGA	Device	Xilinx SpartanR-6 FPGA (XC6LX16-CS324)
	Clock	100 MHz
A/D Converter	Device	Analog Devices AD9283
	Clock	50 MHz
D/A Converter	Device	Analog Devices AD9760
	Clock	50 MHz

that gate current sensing neither needs an additional current sensor nor depends on the gate resistor. This will help integrate the gate-drive circuit [10].

## 5. Experimental Results

Fig. 7 (a) shows experimental waveforms with the previous protection method, and (b) shows those with the proposed protection method. This paper defines the protection time as the period from the time that the collector current starts to rise, to the time that it falls to zero. Note that gate charge waveforms had a small period of delay time against gate voltages and collector currents because they were observed from the DA converter.

The protection time of the previous method was 1210 ns, whereas that of the proposed method was 390 ns. The maximum collector current of the

previous method was 42 A, whereas that of the proposed method was 16 A that is only 1.6 times as large as the rated current.

## 6. Conclusion

This paper has proposed a new short-circuit detection method for an IGBT with detecting the gate charge and gate voltage of the IGBT. The experimental system consists of a real-time monitoring system and a gate-drive circuit that can measure the gate current. The protection time has achieved to be 390 ns that is 68% shorter than the previous method with detecting only gate charge.

## References

- [1] S. Umesawa, M. Yamaguchi, H. Ninomiya, and S. Wakiyama, "New discrete IGBT development for consumer use - application-specific advanced discrete IGBTs with optimized chip design," Proc. of IEEE Intl. Power Electr. Conf., pp. 790-795 (2010)
- [2] K. Yuasa, S. Nakamichi and I. Omura, "Ultra high speed short circuit protection for IGBT with gate charge sensing," Proc. of IEEE ISPSD, pp.37-40 (2010)
- [3] T. Tanimura, Y. Kazufumi, I. Omura, "Full Digital Short Circuit Protection for Advanced IGBTs," Proc. of IEEE ISPSD, pp.60-63(2011)
- [4] R. Chokhawala, J. Catt, and L. Kiraly, "A discussion on IGBT short-circuit behavior and fault protection schemes," IEEE Trans. on Ind. Appl., vol. 13, no. 2, pp. 256-263 (1995)
- [5] V. John, B-S. Suh, and T. A. Lipo, " Fast-clamped short-circuit protection of IGBT's," IEEE Trans. on Ind. Appl., vol. 35, no. 2, pp. 477-486 (1999)
- [6] E.Motto, J.Donlon, S. Ming, K. Kuriaki, T. Iwagami, H. Kawafuji and T. Nakano, "Large package transfer molded DIP-IPM," Proc. of IEEE Ind. Appl. Annu. Meeting, pp.1-5 (2008)
- [7] M. Kudoh, Y. Hohi, S. Momota, T. Fujiwara and K. Sakurai, "Current sensing IGBT for future intelligent power module," Proc. of IEEE ISPSD' 96, pp.303-306 (1996)
- [8] T. Horiguchi, S. Kinouchi, Y. Nakayama, T. Oi, H. Urushibata, S. Okamoto, S. Tominaga, and H. Akagi, "A high-speed protection circuit for IGBTs subjected to hard-switching faults," IEEE APEC, pp. 2519-2525, 2014.
- [9] I. Omura, W. Fichtner, H. Ohashi, T. Ogura, H. Ninomiya, "SMICONDUCTOR DEVICE AND CONTROL METHOD THEREOF," USP 6,153,896(2000)
- [10] R. Herzer, "Integrated gate drive circuit solution," CIPS, pp. 37-46, 2010.