



An Experimental Approach to Examine a Multi-Channel Multi-Hop Wireless Backbone Network

著者	Taenaka Yuzo, Tagawa Masaki, Tsukamoto Kazuya
journal or publication title	Informatica: An International Journal of Computing and Informatics
volume	39
number	4
page range	365-374
year	2015-07-16
URL	http://hdl.handle.net/10228/00006169

An Experimental Approach to Examine a Multi-Channel Multi-Hop Wireless Backbone Network

Yuzo Taenaka¹, Masaki Tagawa^{1,2} and Kazuya Tsukamoto³

E-mail: taenaka@nc.u-tokyo.ac.jp

¹ Information Technology Center, The University of Tokyo, Japan

² Graduate School of Information Science, Nara Institute of Science and Technology, Japan

³ Department of Computer Science and Electronics, Kyushu Institute of Technology, Japan

Keywords: traffic management, channel utilization, experiment, multiple channels, OpenFlow, wireless backbone network, multi-hop network, wireless LAN

Received: July 16, 2015

This paper presents an experimental deployment of a multi-channel multi-hop wireless backbone network (WBN) with an OpenFlow-based traffic management method. Specifically, a set of APs, each of which uses a single but different channel, is connected by Ethernet and thus constructs a Virtual AP (VAP), thereby achieving a WBN with multiple channels. To flexibly control traffic flows transmitted over a multi-channel multi-hop WBN, we propose a simple traffic management method based on the OpenFlow control. In the performance evaluation, we first conduct a preliminary experiment as a lab scale and then deploy a 6-hop WBN enabling to provide the Internet access service in a conference (from proof-of-concept to a practical environment). Since the control messages are inherently transmitted with the introduction of OpenFlow, the way of isolation between control plane and data plane will become a critical issue to actually deploy the proposed system for the Internet service. We additionally employ a wireless control network for the conference experiment. The experimental results show that the proposed WBN can increase the network capacity in accordance with the number of channels, thereby providing significant throughput performance for various applications.

Povzetek: Predstavljena je eksperimentalna analiza več-kanalnega več-skokovnega brezžičnega ogrodja za mreže.

1 Introduction

The use of various mobile devices such as smartphones and tablets is rapidly widespread and is becoming increasingly essential to our daily life. A large amount of data is exchanged for various purposes such as video communication and streaming, and thus it is expected to increase by about 11 times between 2013 and 2018 [1].

Since this growth of the mobile traffic is faster than the increase of the network capacity in the advanced cellular technology such as LTE/4G, cellular carriers are rapidly deploying public WLAN access points (APs) to offload the mobile traffic. However, each WLAN coverage is relatively small so that APs tend to be densely placed within specific locations such as shops and a part of public space, thereby suffering radio interference of APs due to highly overlapped coverage. From these considerations, the way of extending WLAN coverage is essential.

To achieve this, a wireless mesh network (WMN) that extends WLAN coverage attracts much attention. A WMN mainly consists of two sorts of APs: gateway AP (called Internet gateway (IGW)) providing the Internet reachability to other APs and other APs constructing a multi-hop wireless backbone network (WBN) to reach the IGW (i.e., the Internet). Since a WMN can extend its coverage due

to the ease of WBN extension, WMN has been already deployed in relative wide area (e.g., a shopping mall and a city).

However, the existing WMN always suffers a limited network capacity due to the nature of multi-hop transmission on multi-hop network. To offload the mobile traffic, the network capacity of a WBN has to be increased so that it can accommodate the amount of the increasing traffic reliably. In particular, since the mobile traffic basically passes through the IGW (i.e., from/to the Internet), the network capacity on a single route toward the IGW should be increased.

Since the channel capacity is physically limited and an existing WBN has been generally designed to consistently use the same channel even for multi-hop transmission, the network capacity is drastically decreased by the competition of channel access and radio interference of nearby APs along with the increase of traffic and the number of hops. Therefore, the effective use of multiple channels on a WBN is absolutely necessary to expand the network capacity. In existing researches, routing protocols, channel assignments, and MAC protocols handling multiple channels are mainly studied [2–6]. These studies cannot simultaneously use multiple paths (channels) between neighboring two APs due to the limitation of the conventional routing

schemes. Also, since an existing AP hardware only has a few wireless interfaces (IFs) (two IFs generally), the number of channels that the AP can use simultaneously is less than the number of IFs that the AP equips with even when many channels (more than the number of IFs) are vacant.

To physically increase the network capacity, IEEE 802.11n/ac have a function of the channel bonding [7, 8]. In the channel bonding, consecutive channels have to be vacant. However, it is quite difficult to monopolize the use of all vacant channels because there are multiple but not consecutive vacant channels scattered in the 2.4 GHz and 5 GHz bands in a real environment. In preliminary experiments, we observed that there are many vacant channels in the 5 GHz band, which means that the available resources cannot be used effectively. Thus, the flexible way of integrating the scattered channels becomes crucial.

From the distinctive points, two problems should be addressed to increase the network capacity of a WBN. One is the limitation on the number of channels that APs can use simultaneously. Another is under-utilization of the channels in use. To address these problems, we first propose an efficient framework, which is potentially capable of handling the unlimited number of channels in parallel. A multi-channel management framework by exploiting OpenFlow is also presented. To the best of our knowledge, there is no literature that not only focuses on these problems but also applies the OpenFlow based approach to the WBN. We then implement these frameworks in a real AP hardware/software and experimentally deploy two sorts of WBNs (a lab scale proof-of-concept and a 6-hop WBN providing the Internet service). In the experiment, we examine the feasibility of our WBN implementation/deployment and also evaluate the effectiveness of increasing the network capacity.

2 Related work

Many studies attempted to increase the network capacity of a WMN by using multiple channels [2–6]. The majority of them focuses on routing protocols, channel assignments, and MAC protocols [3]. Most studies propose a multi-channel routing protocol [4, 9], which jointly works with channel assignment [5]. The use of multiple channels potentially enables to simultaneously transmit packets, thereby being effective to increase the network capacity. However, the number of channels APs can simultaneously use is limited because a practical AP hardware equips with generally two radios and three radios in maximum as far as we know. Therefore, many studies assume that each AP has only two IFs [5]. Since multiple vacant channels more than two are often available, the number of channels each AP simultaneously uses should be flexibly increased in accordance with the number of vacant channels.

The routing studies basically switch channels (routes) to avoid radio interference. However, these studies cannot simultaneously use multiple links (channels) between two

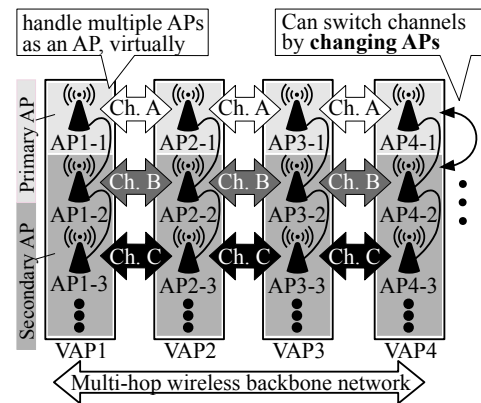

Figure 1: Virtual AP based multi-channel WBN.

neighboring APs because the routing table contains only a single link to reach a neighbor AP. That is, the network capacity between two APs cannot be increased, thereby being a bottleneck. To potentially increase the capacity, packets have to be transmitted through different channels even if all packets are destined to the same destination address. Thus, a traffic management framework that can use multiple channels in parallel is essential.

The studies focusing on MAC protocol try to schedule frame transmissions for collision avoidance between nearby APs [6, 10]. Reference [11] proposes a new MAC protocol transmitting packets on multiple channels based on channel hopping on a single radio (practical hardware equipment). Although it can handle multiple channels, the switching delay in the order of several milliseconds [12] is inherently necessary at every channel switching. It cannot effectively use multiple channels due to the delay and the time-allocated manner. Then, the multiple channels have to be used simultaneously to completely exploit their available resources.

From the viewpoint of OpenFlow, there are few studies employing OpenFlow in WMN [13, 14]. They use OpenFlow functions to provide user mobility in WMN. They mention about the utilization of multiple channels but the structure of WMN is the same with the existing WMN, which does not use multiple channels in parallel. That is, the channel utilization of multiple channel on each hop is not considered.

3 Multi-channel WBN enabling to increase network capacity

3.1 Handling multiple channels

To increase the number of channels that each AP can handle, we employ a virtual AP (VAP) shown in Figure 1. A set of APs (sub-APs), each of which uses a single but different channel for the WBN, is connected by Ethernet of daisy chain and constructs a VAP handling multiple channels. In the WBN constructed by VAPs, since each VAP has mul-

multiple wireless links of different channels with neighboring VAPs simultaneously, switching forwarding path of a flow is the same meaning with switching channels of the flow.

As shown in Figure 1, one AP in each VAP is treated as a primary AP (e.g., AP1-1) and the others are secondary APs. Both the primary and secondary APs construct WBNs on respective channels, while only the primary APs provide the Internet access to client terminals. From this architecture, the number of channels used in parallel can be flexibly increased by adding APs for VAP. Note that, to easily identify each VAP, a VAP is indicated with a number, called VAPID, (=X) such like VAP-X. In the same way, the sub-APs is denoted as AP-X-Y, where Y is a sequence number of APs in a VAP, called APID.

3.2 Channel utilization of WBN

In WBN, we assume that a routing protocol identifies a route toward IGW (e.g., VAP4 → VAP3 → VAP2 → VAP1 in Figure 1)¹ and thus all traffic are forwarded along with the identified route. To use multiple channels on the route, we propose a traffic management framework based on software defined network (i.e., OpenFlow) technology, which enables us to flexibly select a path (channel) for each flow at each hop. A flow is defined based on various identifications from layer 1 to layer 4. In this study, we use a 4-tuple (source/destination IP address and port number) as the flow identification.

OpenFlow consists of one OpenFlow Controller (OFC) and some OpenFlow Switches (OFSs). The OFC establishes a TCP connection with each of OFSs for control message exchange. Then, the OFC determines control rules for each flow (called flow entries) and registers them to OFSs. An OFS (an AP in this study) actually manages packets of each flow by following the registered flow entries stored in the local database (called flow table). Thus, the OFC essentially controls all flow by registering flow entries to OFSs.

A flow entry consists of a flow identification and a corresponding action. In the study, flow entries are registered (a) when an OFS initially connects with the OFC, and (b) when the OFC receives a *packet_in*, which is sent by an OFS whenever the OFS receives an unknown packet (i.e., the packet does not match any flow entries in the flow table). A set of flow entries registered at (a) is fixed rule and is called as *base entry*. Also, the process that the OFC creates/registers a flow entry to an OFS is called as *flow_mod*.

3.3 Traffic management framework

We propose a traffic management framework based on OpenFlow technology. Since a single OFC can collaboratively work with all OFSs and can totally manage all flows through the connected OFSs, the OFC has a potential to dynamically manage flows in response to the variations of the traffic condition in whole WBN. Thus, the channel utilization can be optimized by exploiting the OpenFlow based

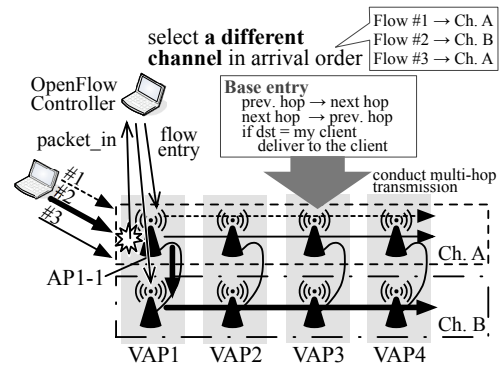

Figure 2: An example of traffic management on multi-channel WBN.

WBN. To evaluate the performance of the OpenFlow based WBN, we here propose a simple channel utilization method that can multiplex a conventional (single-channel) multi-hop transmission as an example method.

In this method, the OFC allocates a channel for each flow in order of the arrival of *packet_in* and the selected channel is persistently used for multi-hop transmission in the WBN. Figure 2 shows the mechanism of the channel utilization method. The OFC initially registers flow entries (base entry) to all OFSs when establishing a control TCP connection with each OFS. The base entry consists of rules that make all APs forward flows from the previous hop to the next hop and from the next hop to the previous hop. Note that, if the destination of the flow is a client device connecting to its VAP, the AP directly delivers the flow to the destination. Thus, all APs have the base entry conducting multi-hop transmission in advance.

When a client terminal starts a new communication (flow), a first packet arrives at one of APs (e.g., AP 1-1 in Figure 2) and the AP sends a *packet_in* to the OFC. The OFC determines the identification of the flow based on the combination of source/destination pairs of <IP address, port number>, selects a channel persistently used on all hops for the flow, and then registers flow entries, which transmits packets of the flow via the selected channel. In the next hop, the flow is transmitted by the base entry in accordance with the transmission direction. In this way, the combination of the base entry and *packet_in* driven flow entry achieves the utilization of multiple channels.

To determine a channel for each flow, the OFC selects a different channel one by one in arrival order of *packet_in*. In Figure 2, as three flows are arriving at VAP1, three respective *packet_ins* reporting those flows are sent to the OFC. The OFC selects a channel for each flow in the arrival order of *packet_in* (i.e., channel A for flow 1, channel B for flow 2, and channel A for flow 3 again) and performs *flow_mod* for arrival flow. Then, each VAP forwards all packets of the flow by using the selected channel. The details of this implementation are presented in the reference [15].

¹Routing is beyond the scope of this paper.

3.4 Overhead introduced by OpenFlow

The delay due to `packet_in/flow_mod` message exchange and the management traffic coming from this message exchange inherently become overhead. When an AP receiving a new flow (a first packet of new flow), the AP sends a `packet_in` to the OFC unless a flow entry matching the flow is registered in the AP. The OFC then selects a channel for the flow and registers new flow entry (`flow_mod`) indicating the selected channel to transmit the flow. After that, the AP starts to forward the flow based on the informed flow entry. Therefore, the delay for registration of flow entry, which highly depends on round trip time (RTT) between the AP and the OFC, is necessary only when receiving a first packet of each flow (i.e., only once for each flow). Moreover, the processing delay for channel selection is also necessary, but it limits to a quite short period. So, the communication interruption period almost becomes RTT between the AP and the OFC.

On the other hand, OpenFlow does not require extra delay to process packets except a first packet of each flow. The OFS process works as a Linux kernel module (kernel process) in each AP and handles packets instead of the TCP/IP stack on the Linux kernel. That is, the OFS process refers to the flow table to forward packets. This kind of process is almost same with the process of the TCP/IP stack, which refers the forwarding information base to forward packets. The paper [13] actually examined the delay by using a userland OFS software and showed that the throughput performance does not depend on the number of flow entries if simple rules (match on port numbers only) are used. Since our method also use only simple rules for all flow entries, the introduction of OpenFlow does not impact on the performance in our study.

From the viewpoint of the amount of management traffic, the amount of traffic by `packet_in/flow_mod` is necessary. A `packet_in` message consists of the OpenFlow header (18 bytes) and the entire frame that triggers a new `packet_in`, while a `flow_mod` contains some flow entries. That is, the amount of each `packet_in` depends on the data frame size but the amount of a `flow_mod` is always same size (150 bytes per frame) in our method. Actually, since we employ UDP with 1500-byte packets (=1514-byte frame), the size of `packet_in` becomes 1598 bytes (= Ethernet/IP/TCP header (66 bytes) + OpenFlow header (18 bytes) + entire frame (1514 bytes)). Also, since our method triggers `packet_in` once when receiving a new flow, the total amount of extra traffic will be proportional to the number of the arrivals in new flows and thus the extra management traffic can be limited to a considerable little value.

4 Lab scale proof-of-concept

To evaluate the proposed multi-channel multi-hop WBN, we first construct a lab scale WBN and demonstrate the feasibility of the proposed WBN.

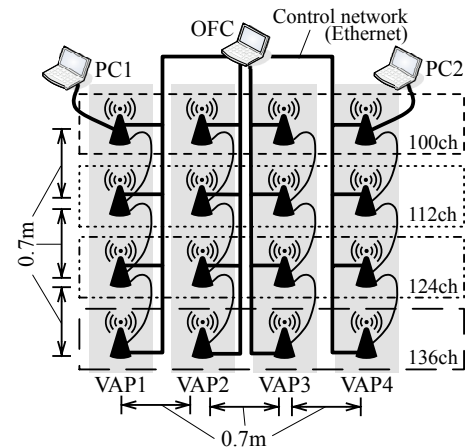

Figure 3: AP placement in the lab scale testbed.

4.1 Facilities and environment

We prepare Buffalo WZR-HP-AG300H as AP hardware. We also install OpenWrt [16] (linux-based OS) with Open vSwitch [17] to all APs. Open vSwitch is a kernel-land OFS software that controls packet transmissions in APs. For the OFC software, we employ Trema [18].

Figure 3 shows the AP placement in the lab scale testbed, which is a 3-hop WBN. Each AP of a VAP is placed to 0.7 m apart from each other and the distance between two neighboring VAPs is 0.7 m. To enable OpenFlow based control, all OFSs (APs) directly connect to an OFC by using dedicated wired network to establish a control connection with the OFC.

In the wireless settings, IEEE802.11a is used to construct the WBN and also four channels (100, 112, 124, and 136 channels) are selectively assigned for the experiment. Note that there is no radio interference on these channels with any other nearby WLANs. To generate traffic, we prepare two PCs, PC1 and PC2. These PCs are connected to AP1-1 and AP4-1 by Ethernet, respectively, because we here focus on the multi-hop data transmission over the WBN.

4.2 Performance measurement in case of UDP traffic

We investigate the maximum network capacity in accordance with the number of channels used in parallel. Note that we define the network capacity as the total throughput at the end host. To keep same traffic rate independent to the network condition, PC1 generates UDP traffic of constant bitrate by using iperf. Specifically, PC1 sends 40 UDP flows (1,500 byte packets) with fixed 1 Mbps to PC2 one by one at 5 seconds interval (totally, 40 Mbps). During the experiment, we measure the total amount of traffic received by PC2 and average the total throughput for 30 seconds after 5 seconds since the last flow starts. This experiment is performed nine times.

Table 1 indicates the summary of measurement results.

Table 1: Total throughput in UDP (Mbps).

	# of channels used in parallel			
	1 ch.	2 ch.	3 ch.	4ch.
Maximum	9.73	19.14	29.03	38.47
Median	9.71	19.05	28.91	38.16
Minimum	9.58	18.96	28.80	38.13

Table 2: Total throughput in TCP (Mbps).

	# of channels used in parallel			
	1 ch.	2 ch.	3 ch.	4 ch.
Maximum	7.67	15.08	22.75	30.14
Median	7.53	15.05	22.66	30.06
Minimum	7.44	14.88	22.60	29.98

In the results, although the total data rate of UDP flows is 40 Mbps, the obtained throughput cannot reach it. Since the traffic is equally distributed in this experiment, all channels on the WBN are exhaustive filled by the traffic. That is, the maximum UDP throughput means the maximum network capacity of the WBN. Then, we can see from the results that the network capacity with a single-channel 3-hop WBN is about 10 Mbps. According to the increase of the number of channels used in parallel, the network capacity also increases. Indeed, it becomes twice in 2 channels and three times in 3 channels. Therefore, our WBN can linearly increase the maximum network capacity in response to the increase of channels.

4.3 Performance measurement in case of TCP traffic

In the Internet access network, there are various flows in which TCP is a dominant. In this experiment, we measure the TCP performance on our WBN while increasing the number of channels used in parallel. TCP has a function that dynamically controls transmission rate depending on the network condition so that traffic congestion could be avoided. Due to the latency of congestion control, we can expect that the network capacity in case of TCP is lower than that in case of UDP. We then examine the (effective) network capacity in the realistic traffic environment.

In this experiment, PC1 performs some TCP data transmissions. Specifically, PC1 establishes a TCP connection with PC2 and transmits data by using iperf through the connection. The number of this TCP flows is increased from one up to 40 one by one at every 5 seconds. As for the capacity, we average the total throughput for 30 seconds after 5 seconds since the last flow starts. This experiment is performed nine times.

Table 2 shows the summary of experimental results. As with Table 1, Table 2 shows that the total throughput is linearly increased in accordance with the number of channels used in parallel. However, the obtained throughput is clearly less than the results in Table 1 due of the congestion

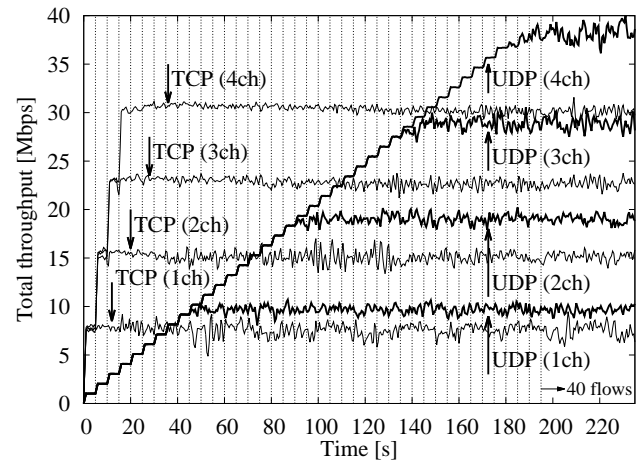

Figure 4: Time series variation on median results.

control mechanism, as stated previously.

We next compare TCP with UDP in the time series shown in Figure 4. To illustrate this figure, we select the median results in Tables 1 and 2. Since the number of UDP flows is gradually increased up to 40 flows at every 5 second, throughput also grows along with the increase of flows until the maximum network capacity, which is determined by the number of channels used in parallel. On the other hand, in TCP experiment, once at least one flow is transmitted on every channel, the total throughput is kept in almost same value irrespective of the number of TCP flows (before the number of flows reaches to 40). Moreover, after all flows start to be transmitted, the TCP throughput is about 2Mbps lower on each channel than that of UDP. That is, it is totally 8 Mbps lower in case of the 4-channel WBN. From these results, we can say that our WBN can potentially increase the network capacity in accordance with the number of channels used in parallel but the effective capacity is different depending on the characteristics of traffic.

5 WBN providing the Internet access

We deploy our WBN to provide the Internet access for conference attendees. The conference is held at a single floor of a hotel and our WBN is deployed in a part of the floor. The number of conference attendees is 133 but only a part of them uses our Internet access service because other Internet services are also available and some attendees use them. The installation environment with wireless configuration is described in Section 5.1. In this experiment, we employ an additional AP (namely assistant AP), whose roles are described in Section 5.2. The design of AP placement is explained in Section 5.3. Finally, we show the results of performance measurement in Section 5.4.

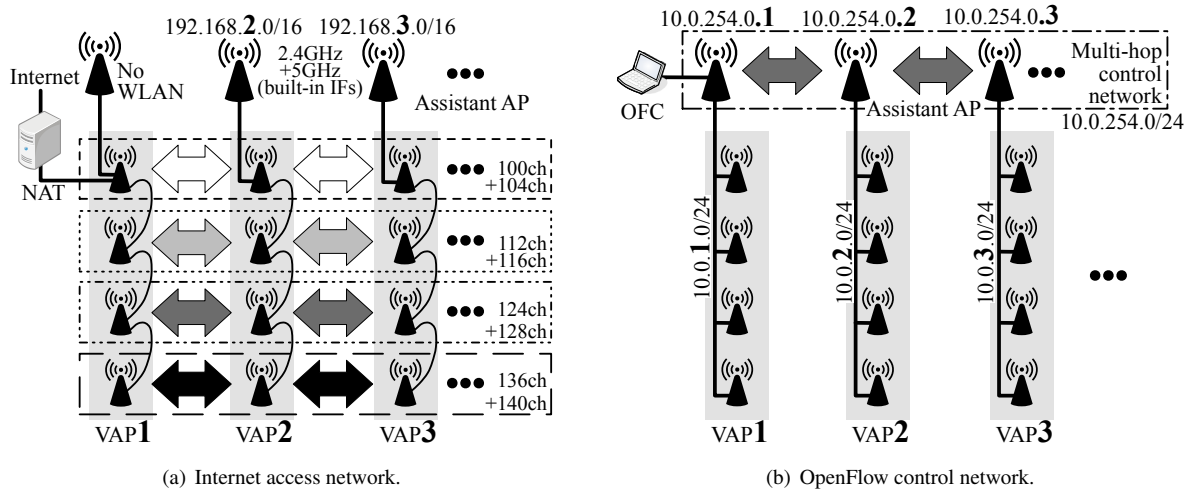

Figure 5: Construction of an experimental network.

5.1 Installation environment

As shown in the lower part of Figure 5(a), we employ four APs for each VAP (i.e., four channels available on WBN). These four APs are connected by Ethernet of daisy chain and compose a VAP. Each AP uses the channels of 100, 112, 124, and 136 for WBN, respectively.

In the WLAN settings on all APs, IEEE802.11n is used and an adjacent channel is bonded (i.e., 40 MHz channel bonding is activated). For example, the channel 104 is bonded with the channel 100. It should be noted that our proposed WBN framework can adapt to change in the wireless technology such as 802.11ac and its channel bonding technology. We then manage user traffic through these four links by our proposed channel utilization method described in Section 3.3. Note that we confirmed that there is no radio interference on these channels with any other nearby WLANs in the hotel.

5.2 Assistant APs

We have investigated the basic performance of a lab scale WBN in Section 4. Since our focus was the way of constructing the WBN and its performance, we simplified the experimental environment, as described in Section 4.1.

Each VAP must provide WLAN access for the Internet service. Also, to deploy our proposed WBN in a large scale network, the control traffic arising from OpenFlow should be conveyed on wireless network. Thus, we additionally prepare a Buffalo WZR-HP-AG300H equipped with a USB wireless IF (i.e., this AP has two built-in IFs and one USB IF) for each VAP, called assistant AP. The assistant AP allows us not only (1) to provide WLAN access to client terminals but also (2) to construct the control network, as shown in Figure 5.

5.2.1 Providing the WLAN access

To achieve (1), an assistant AP provides WLAN access in both 2.4 and 5 GHz bands by using two built-in IFs (Figure 5(a)). These WLANs are configured as IEEE802.11n with 20 MHz channel width (i.e., the channel bonding is not used for client user access).

These two IFs and one Ethernet port of the assistant AP are bridged in layer 2 based on the Linux bridge module in OpenWrt and the Ethernet port is connected to the primary AP (i.e., AP-X-1) by Ethernet. The primary AP then acts as a DHCP server and dynamically allocates an IP address for each client terminals in accordance with VAPID. For example, when a client terminal associates with the assistant AP of VAP2 on the 2.4GHz or 5GHz bands, an IP address in 192.168.2.0/16 is assigned for the client terminal by AP2-1. From this structure, the primary AP can handle user traffic of all client terminals associating with the assistant AP through the Ethernet port.

5.2.2 Control network conveying OpenFlow message

To carry the control messages between an OFC and OFSs, the IP reachability between an OFC and OFSs have to be guaranteed in advance. However, OFS's IFs controlled by OpenFlow cannot receive/transmit any packets until the connection between the OFC and the OFS is established because the OFS does not have any flow entries at first. Thus, the OFS cannot reach the OFC through our WBN. To solve the problem, the control network must be constructed separately from the user network (i.e., WBN). We then prepare the dedicated control network constructed by assistant APs, which are not managed by OpenFlow.

Figure 5(b) illustrates the dedicated control network. The assistant AP connects with all sub-APs by Ethernet cables. To guarantee the IP reachability between the OFC and all OFSs, the assistant APs construct a multi-hop wireless network based on static routing by using the USB wire-

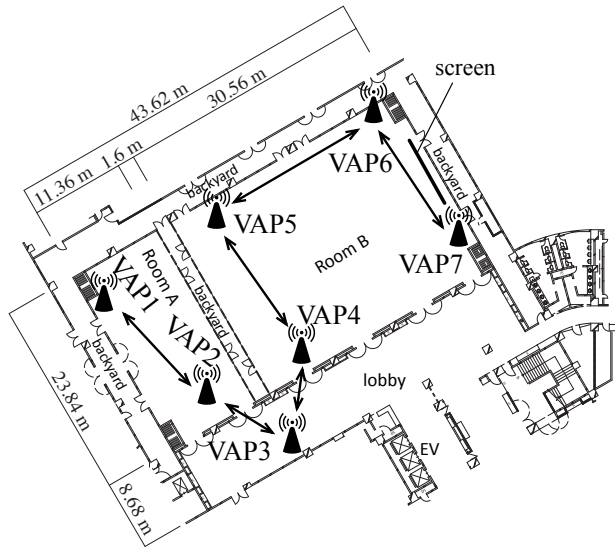

Figure 6: Map of VAP placement in the experimental deployment.

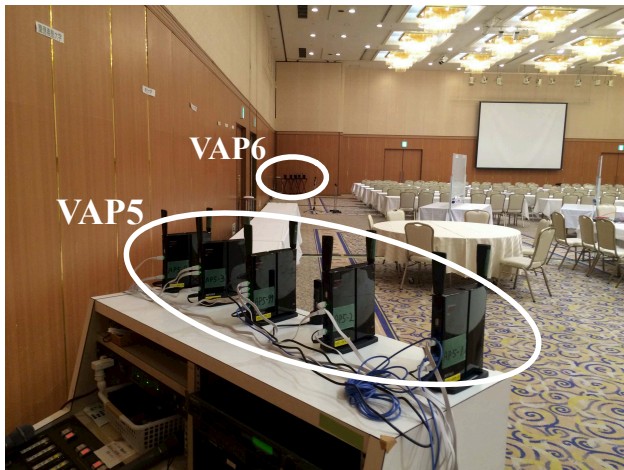

Figure 7: Actual placement of VAP5 and VAP6.

less IF. Since the multi-hop control network is not managed by OpenFlow but a conventional IP routing based network, each OFS can communicate with the OFC in advance. It should be noted that, since this paper focuses on how to use multiple channels on a large scale WBN, the feasibility of the control network will be addressed in the future work.

5.3 AP placement

Figure 6 shows a map of a part of the conference venue with the AP placement. We place seven VAPs in two rooms (Room A and B). An example of the VAP deployment (VAP5 and VAP6) is shown in Figure 7. As seen in the figure, we adjust the location of VAP so as to have line-of-sight between two neighboring VAPs. That is, doors between VAP2 and VAP3 and between VAP3 and VAP4 are always opened.

VAP1 located in Room A is the IGW and directly con-

Table 3: Throughput for 30 seconds (Mbps).

Maximum	Median	Minimum
30.61	28.94	27.31

nects with the OFC. That is, user traffic and control traffic of OpenFlow must pass through VAP1. To ensure that user traffic is forwarded in multi-hop, VAP1 (i.e., the assistant AP of VAP1) does not provide the WLAN access to client terminals as shown in Figure 5(a). Instead, VAP1 (the primary AP of VAP1) connects to a router, which performs NAT of 192.168.0.0/16, so that all users can access the Internet.

Since our proposed WBN can construct only a chain topology with static routing at this time, we design a 6-hop chain topology with a pre-defined path, which is shown by arrows in Figure 6. Thus, all user traffic is forwarded on this multi-hop WBN along with the path.

In the conference, Room A is used for a meeting and Room B is for a plenary event. Since the conference attendees concentrate in Room B when a plenary event is held, we place VAP6 and VAP7 around the plenary event area. As shown in Figure 7, the plenary event area is right side of Room B (in front of the screen) and thus almost attendees may associate with VAP6 or VAP7.

5.4 Performance measurement

We measure the network capacity by obtaining the sum of throughput of all flows on the WBN. In Section 5.4.1, we investigate the maximum network capacity when no users utilize the WBN. Section 5.4.2 evaluates the practical network capacity when many users simultaneously access the Internet by using various applications.

5.4.1 Maximum network capacity

We obtain the maximum performance of the WBN. In this experiment, two PCs connect to VAP1 and VAP7 by Ethernet, respectively, and UDP traffic is transmitted from VAP7 to VAP1 to obtain the maximum network capacity of a 6-hop WBN. During this experiment, there is no other traffic than the experimental UDP traffic.

In the preliminary experiment, we investigated the UDP transmission rate that meets the maximum channel capacity of a 6-hop WBN with a single channel (Figure 6). The measurement is conducted by increasing transmission rate of UDP with 1,500-byte packet by iperf. Since we find that 8 Mbps is the maximum capacity of a channel (packet loss rate is less than 1%) in advance, we here use this traffic rate to measure the network capacity of our WBN.

In the experiment, we generate four 8-Mbps UDP flows with 1,500-byte packets at 10 seconds interval. The throughput is averaged for 30 seconds after 5 seconds since the last flow starts, and this experiment is performed nine times. Table 3 indicates the measurement results. From

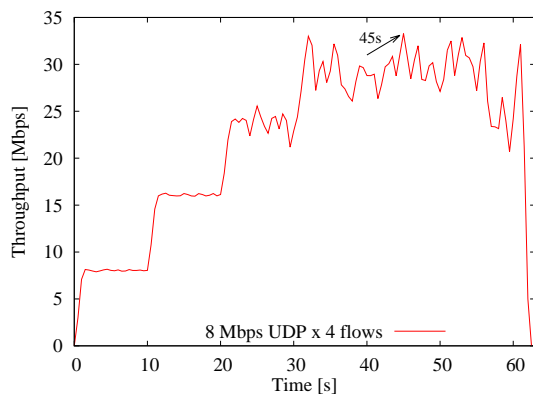

Figure 8: Time series throughput of the average result on the median result.

the table, we can see that the proposed WBN can provide around 29 Mbps of the network capacity.

Figure 8 shows the time series throughput of the median result in Table 3. In the figure, we can see that the throughput dynamically fluctuates between 25 and 30 Mbps. Also, the maximum instantaneous throughput is 33.28 Mbps at 45 seconds. From these results, we can say that the proposed WBN potentially has 29 Mbps of the network capacity.

5.4.2 Practical network capacity

We next treat a case where clients (conference attendees) use the WBN to reach the Internet. To obtain the practical network capacity, we measure the total throughput at VAP1 during a plenary event. As a measurement result, we intentionally select the period of 10 minutes during the conference when the largest amount of traffic is observed. Figure 9 shows the actually measured traffic forwarded from/to each VAP during the 10 minutes in time series. From Figures 9(a) and 9(b), we can see that the amount of the downstream traffic is extremely larger than that of the upstream traffic, i.e., about 0.5 Mbps upstream traffic and about 25 Mbps downstream traffic. That is, the asymmetric nature of the Internet traffic can be seen.

From Figure 10, we can see that almost traffic is from/to VAP6 and VAP7. When focusing on VAP7, the throughput measured at 254 seconds is 30.42 Mbps, which is the maximum instantaneous traffic during 10 minutes but a little less than that of UDP experiments (Section 5.4.1). We also show that the stable throughput on VAP7 is around 26 Mbps. Since the WBN of this experiment provides the WLAN Internet access to client terminals, TCP traffic is likely to be dominant in the Internet. As evaluated in Section 4, TCP cannot completely utilize the network capacity due to its congestion control mechanism. Therefore, the network capacity utilized by TCP becomes a little less than the results in Section 5.4.1.

From above results, the OpenFlow based WBN can aggregate the capacity of multiple channels efficiently,

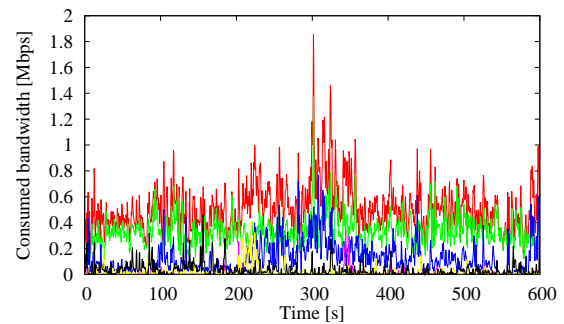

(a) Consumed bandwidth on upstream.

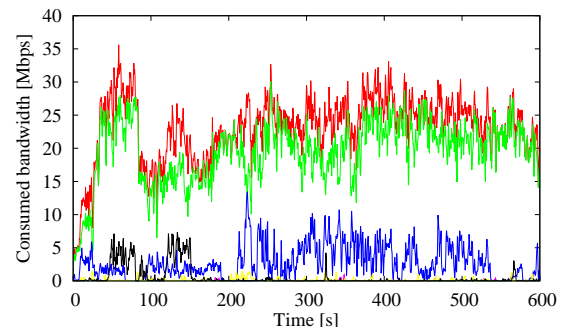

(b) Consumed bandwidth on downstream.

Figure 9: Consumed bandwidth for 10 minutes during a plenary event.

thereby providing the Internet access with the large network capacity. In summary, we can conclude that the WBN can effectively extend WLAN coverage while maintaining the large network capacity.

6 Discussion

In this paper, we prepared the experimental environment with no difference/variation of wireless link quality and then conducted experiments to perform the proof-of-concept of the proposed architecture handling multiple channels efficiently. To apply it to the real deployment, we still have some concerns including the difference/variation on wireless condition, the difference/variation on communication, reliability of control network, scalability, and deployment.

In a real deployment, APs may be distributed in wide area so that the radio range of a AP is adjusted to reach only nearby APs. In such a deployment, wireless condition differs in every hop and changes dynamically (e.g., due to radio interference). Since we assume same and stable (no variation of wireless condition) environment in this study, how to apply the proposed method in a real deployment should be further considered. Indeed, when the OFC receives packet_in, the channel selection should be conducted in accordance with the channel condition. While the WBN is transmitting a flow, the OFC should effectively control the channel utilization (switches channels of the

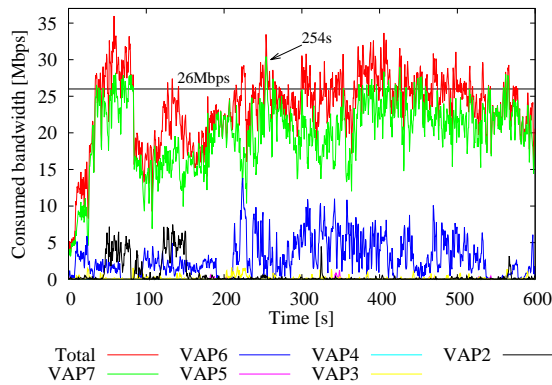

Figure 10: Total bandwidth during the event.

flow) along with the change of channel condition.

To adaptably utilize channels, the OFC has to quickly obtain the difference and variation of wireless condition and then flexibly control the channel utilization. However, since OpenFlow is originally designed for point-to-point wired network, it is not capable of treating point-to-multipoint wireless network, i.e., the OFC cannot obtain any wireless information. To overcome this, the OFC may estimate the wireless link condition based on OpenFlow technology. Actually, since the OFC is capable to collect the amount of sent/received traffic in each AP, the OFC may be aware of the difference or degradation of wireless link quality by comparing the amount of sent traffic in an AP with the amount of the received traffic on the next hop. In this way, we also need to develop the way of obtaining the wireless link condition and accordingly controlling the channel utilization.

Since various sorts of communication are conducted in a real WMN, the channel utilization method has to handle them to effectively utilize multiple channels. Since the flow arrival timing, flow length, and transmission rate are various, the optimization of channel utilization is extremely difficult. That is, some channels may be saturated even if other channels are not full yet. Although the OFC selects a different channel in the order of packet_in arrival in this paper, the amount traffic loaded on each channel may also be additionally considered to utilize multiple channels.

The reliability of OFC and control network should be considered to employ OpenFlow. Since the focus of this paper is proof-of-concept, we actually have not ensured the reliability yet. For improving the OFC reliability, a simple way that prepares multiple OFCs in the WBN may be effective. On the other hand, to keep the control network reliable, it must have redundancy because there is a single point of failure in the current control network. Specifically, since a multi-hop network with a single channel is dedicated for the control network in the current WBN, the WBN causes communication failures if one of wireless links in the control network is disturbed or disconnected. To avoid it, the control network should be construct by multiple channels. Since the channel resources are limited, the

control traffic may be coexistent with the data traffic in our WBN.

The scalability issue of the control network should be addressed. As described in Section 3.4, the delay of packet_in/flow_mod delay may increase in accordance with the WBN size. Moreover, the saturation of the control network should be considered. A dedicated channel is used for a multi-hop control network in our WBN. On one hand, the number of clients (flows) tends to increase in accordance with the WBN size (i.e., the coverage area). The control traffic may be dropped due to the saturation of control network in the extensive WBN. These concerns should be further investigated.

Finally, to actually deploy the WMN based on our WBN, we have to consider the configuration and deployment way. In the current WBN, we configure all APs in advance so that all wireless connections including the control network are certainly established. For the deployment, it is necessary to establish the wireless connection and then detect the topology (neighboring APs). Since as we described above the OpenFlow has no functions for wireless network, we need to further develop a way to handle wireless information in the OpenFlow technology. Actually, monitoring beacon frames may be useful to obtain the availability of the channels and collect the information of neighboring APs.

7 Conclusion

To increase the network capacity, this paper introduces the OpenFlow based WBN and a channel utilization method. The WBN is examined in two sorts of testbed. First, we evaluate the basic characteristics of a lab scale proof-of-concept. In the testbed, since we simplified the experimental environment (i.e., client nodes are connected to AP by an Ethernet cable and also the control messages of OpenFlow are conveyed through the wired network), we need to provide WLAN access to client terminals and to construct the wireless network for transmitting control messages.

To solve these problems, we employ an additional AP and then deploy the WBN in a large-scale testbed providing the Internet access to conference attendees. In the measurement, we can demonstrate that the WBN can bring the large amount of network capacity in 6-hops with 4 channels. From the results of two experiments, we can conclude that our WBN can extend WLAN coverage while linearly increasing the network capacity in accordance with the number of channels used in parallel. Since this study focuses on the proof-of-concept of our WBN, we next plan to solve remaining concerns including the difference/variation on wireless condition, the difference/variation on communication, reliability of control network, scalability, and deployment.

Acknowledgment: This work was partly supported by the Telecommunications Advancement Foundation, Japan.

References

- [1] Cisco Visual Networking Index. Global Mobile Data Traffic Forecast Update, 2013–2018. http://www.cisco.com/c/en/us/solutions/collateral/service-provider/visual-networking-index-vni/white_paper_c11-520862.pdf.
- [2] P. H. Pathak and R. Dutta. A Survey of Network Design Problems and Joint Design Approaches in Wireless Mesh Networks. *IEEE Communications Surveys and Tutorials*, 13(3):396–428, 2011.
- [3] D. Benyamina, A. Hafid, and M. Gendreau. Wireless Mesh Networks Design - A Survey. *IEEE Communications Surveys and Tutorials*, 14(2):299–310, 2012.
- [4] E. Alotaibi and B. Mukherjee. Survey Paper: A Survey on Routing Algorithms for Wireless Ad-Hoc and Mesh Networks. *Computer Networks*, 56(2):940–965, February 2012.
- [5] W. Si, S. Selvakennedy, and A. Y. Zomaya. An Overview of Channel Assignment Methods for Multi-radio Multi-channel Wireless Mesh Networks. *Journal of Parallel and Distributed Computing*, 70(5):505–524, May 2010.
- [6] K. S. Vijayalayan, A. Harwood, and S. Karunasekera. Distributed Scheduling Schemes for Wireless Mesh Networks: A Survey. *ACM Computing Survey*, 46(1):14:1–14:34, July 2013.
- [7] IEEE Std 802.11n-2009.
- [8] IEEE Std 802.11ac-2013.
- [9] A. Raniwala, K. Gopalan, and T. Chiueh. Centralized Channel Assignment and Routing Algorithms for Multi-channel Wireless Mesh Networks. *SIGMOBILE Mob. Comput. Commun. Rev.*, 8(2):50–65, 2004.
- [10] P. Kyasanur, J. So, C. Chereddi, and N. F. Vaidya. Multichannel mesh networks: challenges and protocols. *IEEE Wireless Communications*, 13(2):30–36, May 2006.
- [11] J. So and N. H. Vaidya. Multi-channel Mac for Ad Hoc Networks: Handling Multi-channel Hidden Terminals Using a Single Transceiver. In *MobiHoc*, pages 222–233, 2004.
- [12] A. Raniwala and T. Chiueh. Architecture and algorithms for an IEEE 802.11-based multi-channel wireless mesh network. In *INFOCOM*, pages 2223–2234, 2005.
- [13] P. Dely, A. Kessler, and N. Bayer. OpenFlow for Wireless Mesh Networks. In *IEEE ICCCN*, pages 1–6, 2011.
- [14] A. Detti, C. Pisa, S. Salsano, and N. Blefari-Melazzi. Wireless Mesh Software Defined Networks (wmSDN). In *2nd International Workshop on Community Networks and Bottom-up-Broadband*, pages 89–95, 2013.
- [15] M. Tagawa, Y. Wada, Y. Taenaka, and K. Tsukamoto. Network Capacity Expansion Methods based on Efficient Channel Utilization for Multi-Channel Wireless Backbone Network. In *the 2014 International Workshop on Smart Complex Engineered Networks (SCENE)*, August 2014.
- [16] OpenWrt. <https://openwrt.org/>.
- [17] Open vSwitch. <http://openvswitch.org/>.
- [18] Trema. Full-Stack OpenFlow Framework in Ruby and C. <http://trema.github.io/trema/>.