

MATRIX ACIDIZING CORE FLOODING APPARATUS: EQUIPMENT AND  
PROCEDURE DESCRIPTION

A Thesis

by

ELIZABETH RACHEL GRABSKI

Submitted to the Office of Graduate Studies of  
Texas A&M University  
in partial fulfillment of the requirements for the degree of

MASTER OF SCIENCE

Approved by:

Chair of Committee,	A. Daniel Hill
Committee Members,	Ding Zhu
	Zhengdong Cheng
Head of Department,	A. Daniel Hill

December 2012

Major Subject: Petroleum Engineering

Copyright 2012 Elizabeth Rachel Grabski

## ABSTRACT

Core flooding is a commonly used experimental procedure in the petroleum industry. It involves pressurizing a reservoir rock and flowing fluid through it in the laboratory. The cylindrical rock, called a core, can be cut from the reservoir during a separate core drilling operation or a formation outcrop. A core flooding apparatus suitable for matrix acidizing was designed and assembled. Matrix acidizing is a stimulation technique in which hydrochloric acid (HCl) is injected down the wellbore below formation fracture pressure to dissolve carbonate ( $\text{CaCO}_3$ ) rock creating high permeability streaks called wormholes.

The main components of the apparatus include a continuous flow syringe pump, three core holders, a hydraulic hand pump, two accumulators, a back pressure regulator, and two pressure transducers connected through a series of tubing and valves. Due to the corrosive nature of the acid, the apparatus features Hastelloy which is a corrosion resistant metal alloy. Another substantial feature of the apparatus is the ability to apply 3000psi back pressure. This is the pressure necessary to keep  $\text{CO}_2$ , a product of the  $\text{CaCO}_3$  and HCl reaction, in solution at elevated temperatures.

To perform experiments at temperature, the core holder is wrapped with heating tape and surrounded by insulation. Tubing is wrapped around a heating band with insulation to heat the fluid before it enters the core. A LabVIEW graphical programming code was written to control heaters as well as record temperature and pressure drop across the core. Other considerations for the design include minimizing footprint, operational ease

by the user, vertical placement of the accumulators and core holders to minimize gravity effects, and air release valves.

Core floods can be performed at varying injection rates, temperatures and pressures up to 5000psi and 250 degF. The apparatus can handle small core plugs, 1'' diameter X 1'' length, up to 4'' X 20'' cores. The equipment description includes the purpose, relevant features, and connections to the system for each component. Finally documented is the procedure to run a core flooding test to determine permeability and inject acid complete with an analysis of pressure response data.

## DEDICATION

To everyone who supported me in all their different ways.

## ACKNOWLEDGEMENTS

I would like to thank my committee chair, Dr. Hill, and my committee members, Dr. Zhu, and Dr. Cheng. I am truly honored to be part of Dr. Hill's and Dr. Zhu's graduate research group. I want to thank them for their patience, guidance, and support which transcends beyond just academics. I've really enjoyed my time and I can't thank them enough for this opportunity. I would also like to thank Qatar Petroleum for their sponsorship of my project as well as the Texas A&M faculty and staff who I only hope know how much we appreciate them. Finally, thanks to my family for all their support and the great friends I've met here at Texas A&M.

## TABLE OF CONTENTS

	Page
ABSTRACT .....	ii
DEDICATION .....	iv
ACKNOWLEDGEMENTS .....	v
TABLE OF CONTENTS .....	vi
LIST OF FIGURES.....	viii
LIST OF TABLES .....	xi
 CHAPTER	
I INTRODUCTION.....	1
1.1 Core Flooding for Petroleum Engineering Applications.....	1
1.2 Matrix Acidizing Fundamentals .....	2
1.3 Matrix Acidizing Core Flooding .....	3
1.4 Apparatus Requirements.....	4
1.5 Objective and Approach .....	7
II EQUIPMENT DESCRIPTION AND INITIAL ASSEMBLY.....	8
2.1 Equipment Summary .....	8
2.2 Fluid Flow and Schematics.....	10
2.3 Core Holders.....	15
2.4 Overburden Pump.....	17
2.5 Injection Pump.....	19
2.6 Accumulators.....	21
2.7 Refill Tank.....	23
2.8 Back Pressure Regulator.....	24
2.9 Pressure Transducers .....	26
2.10 Pressure Gauges.....	28
2.11 Heaters .....	29
2.12 Valves .....	35
2.13 Tubing.....	39
2.14 Fittings and Unions.....	40
2.15 Frame.....	42

III	DATA ACQUISITION HARDWARE AND SOFTWARE DESCRIPTION.....	44
3.1	PCI 6221 DAQ Card and Pin-out Board .....	45
3.2	USB 9221 .....	46
3.3	Software.....	47
IV	PROCEDURE: MATRIX ACIDZING APPARATUS OPEARATION.....	57
4.1	Safety Precautions .....	58
4.2	Pre-Core Flood Procedures.....	60
4.3	Apparatus Preparation .....	63
4.4	Core Flooding Procedure.....	72
4.5	Post Acidizing Procedure .....	86
4.6	Common Errors .....	88
V	DATA ANALYSIS AND RESULTS.....	90
5.1	Recorded Core Data.....	90
5.2	Generating Graph .....	91
5.3	Calculations .....	93
VI	CONCLUSION.....	96
	REFERENCES.....	97

## LIST OF FIGURES

FIGURE	Page
2.1. Matrix acidizing schematic for outlet fluid fill.....	12
2.2 Matrix acidizing schematic with valve series labeled .....	12
2.3 Matrix acidizing schematic for gas flow back .....	13
2.4 Matrix acidizing schematic with frame .....	13
2.5. Matrix acidizing schematic for dual core flood .....	15
2.6. Core holders .....	16
2.7. Core holder dimensions.....	16
2.8. Hassler type core holder diagram.....	16
2.9. Overburden pump.....	18
2.10. Syringe pump .....	20
2.11. Syringe pump with electric valve system.....	20
2.12. Accumulators and refill tank.....	24
2.13. Back pressure regulator.....	26
2.14. Pressure transducers with valve series .....	28
2.15. Pressure gauges .....	29
2.16. Heating tape assembly.....	31
2.17. Fluid heater.....	32
2.18. Fluid heater in frame .....	32
2.19. Solid state relays in electrical box.....	34



2.20. Apparatus valves .....	36
2.21. Swagelok 2-way ball valve interior structure.....	36
2.22. HiP 180° 3-way ball valve.....	36
2.23. HiP relief valve dimensions .....	37
2.24. Compression fittings from Swagelok .....	41
2.25. Unions from Swagelok .....	41
2.26. Assembled apparatus with frame .....	43
3.1. National Instruments hardware and computer .....	45
3.2. Electric box with NI pin-out board .....	46
3.3. PCI-6221 68-pin schematic.....	46
3.4. National Instruments USB 9221 .....	47
3.5. LabVIEW front panel.....	50
3.6. LabVIEW back panel .....	52
3.7. Pressure monitoring task in back panel.....	54
3.8. Temperature monitoring task in back panel .....	55
3.9. Temperature control task in back panel .....	56
4.1. CT Scanner .....	61
4.2. Saturation cell in lab 821 .....	62
4.3. Vacuum pump .....	62
4.4. Hydrochloric acid preparation.....	64
4.5. Stationary platen, banana bolt, and end cap.....	66
4.6. Floating platen, tightening assembly and end cap.....	66

4.7. Core holder with heating tape .....	66
4.8. Core holder mounting components .....	67
4.9. Mounting attached to core holder.....	67
4.10. Mounting attached to frame .....	67
4.11. Syringe pump and controller .....	69
4.12. Nitrogen tanks .....	78
4.13. LabVIEW front panel parameters .....	81
5.1. Automatically generated excel spreadsheet from recorded data .....	92
5.2. Pressure drop vs time graph data.....	93
5.3. Experiment data sheet .....	95

## LIST OF TABLES

TABLE		Page
2.1	Main components and vendors.....	9
2.2	Valve list .....	38
2.3	Tubing location .....	39
4.1	Valve configuration for acid refill.....	72
4.2	Valve configuration for brine refill .....	72
4.3	Valve configuration for core 1, PT 1.....	75
4.4	Valve configuration for core 1, PT 2.....	75
4.5	Valve configuration for core 2, PT 1.....	75
4.6	Valve configuration for core 2, PT 2.....	75
4.7	Valve configuration for injection pump to accumulator air release.....	77
4.8	Valve configuration for accumulator to core 1 & core 2 air release .....	77
4.9	Valve configuration for core 1, BPR fill.....	77
4.10	Valve configuration for core 2, BPR fill .....	77
4.11	Valve configuration for core 1, brine injection .....	84
4.12	Valve configuration for core 2, brine injection .....	84
4.13	Valve configuration for core 1, acid injection.....	85
4.14	Valve configuration for core 2, acid injection.....	85
4.15	Valve configuration for acid discharge .....	88
4.16	Valve configuration for brine discharge.....	88

## CHAPTER I

### INTRODUCTION

#### 1.1 Core Flooding for Petroleum Engineering Applications

A basic core flooding set up has a core holder, overburden pump, injection pump, accumulator, pressure gauges, and a back pressure regulator. The core, or the cylindrical rock, can be drilled from a surface outcrop or from the reservoir during a core drilling operation. To get a core from the field, the normal drill string is removed and a rotary coring bit is attached with a hollow center that catches the core in the center as it drills. The drill string is then brought up to surface and the core is taken out. This is a very expensive operation, so it is not routinely done. Another option is to cut a core from an outcrop, which is a section of the rock formation that has been uplifted due to tectonic activity and is exposed at the surface. The core is then preserved and sent to the laboratory for testing. It is important to point out that the core is only a small sample of the reservoir. Therefore, core flooding results can be used as a guide, though are not expected to precisely predict well performance especially in highly heterogeneous reservoirs.

The American Petroleum Institute has issued a set of standards, Recommended Practices for Core Analysis: Recommended Practice 40<sup>1</sup>. This document describes coring programs, well site core handling procedures and preservation, core screening and

---

<sup>1</sup> The status of this publication according to the API standards is “withdrawn” indicating it is no longer in circulation and by definition, should be reviewed for possible replacement or superseding documents.

preparation, fluid saturation determination, porosity determination, permeability determination, supplementary tests, and reporting.

The basic technique is to place the cylindrical rock into a core holder and pressurize it to simulate overburden pressure conditions similar to the field. An injection pump then pushes the fluid through the core while pressure drop and flow rate are measured. A back pressure is applied at the outlet of the core to maintain single phase flow. This technique can be applied for numerous types of investigations including rock-fluid interactions, testing new chemical additives, and enhanced oil recovery processes in a laboratory setting before it is applied to the field. Core flooding experiments are also used to validate numerical models to predict field production.

## 1.2 Matrix Acidizing Fundamentals

Matrix acidizing is a stimulation procedure in which acid is injected into the reservoir below formation fracture pressure to dissolve particles that plug pore spaces near the wellbore. The formation damage is caused by drilling, completion or production operations and is quantified as a skin factor. The acid, primarily hydrochloric acid (HCl) or hydrofluoric acid (HF), reacts with and dissolves minerals near the wellbore enlarging pore spaces increasing near wellbore permeability. The intent of matrix acidizing is to increase near wellbore permeability and therefore should be applied when high skin factors are suspected that cannot be attributed to mechanical effects (Economides et al 1994). Hydrofluoric acid is typically used in sandstone reservoirs, removing damage within a range of a few inches to a foot around the wellbore. This paper will focus on

carbonate reservoirs made of predominantly calcite or dolomite, which strongly react to hydrochloric acid according to the following reactions:

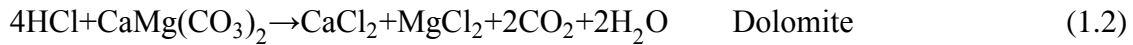
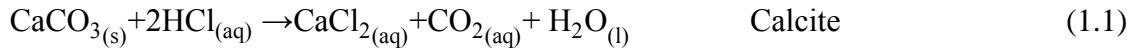

The dissolution creates etching patterns called wormholes which are the dominant flow path for hydrocarbon production. Wang et al 1993 investigated the effect of injection rate on wormhole growth. Injection rate too low results in dissolution of the face, though will not extend far enough to break through the damage zone. An injection rate too high will create ramified wormholes. The optimum rate is when a single dominant wormhole is created.

### 1.3 Matrix Acidizing Core Flooding

Core flooding assists in the understanding of matrix acidizing in a variety of areas including understanding wormhole growth, determining optimum injection rate, and fluid additive interactions among others. The shape and penetration pattern of wormholes has been extensively studied since this controls the post treatment skin effect. According to Frick et al 1994, creating an optimum wormhole is central to the acidizing design. The dissolution pattern and wormhole penetration is complex with models being developed to predict the growth to assist in treatment design. Core size has proven to be an important factor in correctly modeling wormhole growth as investigated by Furui et al., 2010 . The optimum injection rate for a matrix acidizing treatment published by Wang et al in 1993, used core flood experiments to validate the findings. Mostofizadeh and Economides, 1994 and Izgec et al., 2008 extended the optimum injection rate

investigate using radial tests and less idealized heterogeneous cores respectively. Finally, Frenier and Hill 2002, among others showed effects of acid additives on matrix treatments using linear core flood tests. Gomez 2006 and Keys 2009 are prior thesis describing matrix acidizing core flooding apparatus.

## 1.4 Apparatus Requirements

### *1.4.1 Pressure*

A key feature of the apparatus is the back pressure requirement. A back pressure of 3000psi is needed to keep the CO<sub>2</sub> in aqueous solution as it occurs in the field under high temperature (Mumallah, 1991). Since the back pressure is 3000 psi, the injection pressure must be higher than this. The injection pressure is dependent on the permeability of the rock and flow rate, though experiments are not expected to exceed a delta P of 2000 psi. Therefore, the injection pump pressure requirement is 5000 psi. The entire system and components were rated to at least 5000psi.

### *1.4.2 Air Release*

Gas and air must be minimized in the system in order to ensure single phase flow. The presence of air causes erratic pressure responses due to the compressibility. For this reason, air release valves are placed to release air that can be trapped in the top of the accumulator, bottom of the accumulator and directly before core injection.

### *1.4.3 Temperature*

Heat and thermal properties can greatly influence and effect rock fluid system interactions including flow characteristics such as relative permeability and porosity. In

general, both porosity and permeability decrease with increased stress and temperature. The mechanisms that cause the thermal effects are quite complicated, which can be measured by different thermal properties. In matrix acidizing experiments, a number of studies have been performed proving the necessity of performing floods at reservoir thermal conditions. Wang et al in 1993 found three major observations as the temperature increased in a dolomite core: the optimum injection rate increased, smaller acid volume was required to achieve breakthrough, and the inlet face appearance changed from a spongy to single wormhole entry. Limestone revealed similar trends though required larger acid volume required for breakthrough. Therefore, the apparatus was designed so core floods can be performed at temperatures up to 300 deg F.

#### *1.4.4 Material*

Hydrochloric acid is very corrosive. The components that contact high concentrations of acid must be made out of a specialized alloy, Hastelloy C. In previous core flooding experiments with stainless steel tubing performed at elevated temperatures, iron precipitate was observed at the inlet face of the core. Also, the Hydrochloric acid fumes attack the computer wiring and therefore these components are contained in an electric box. Other components are made out of stainless steel 316 which is a readily available material for components with high pressure ratings. It should be noted that industry matrix acidizing users commonly use stainless steel for the valve, unions, and tubing. The high price, more restricted options and availability of Hastelloy makes it more economical to use stainless steel components and change out components more frequently.



#### *1.4.5 Core Holder Size and Position*

Another key feature of the apparatus is the variation in core holder sizes. Depending on the heterogeneities in reservoirs, larger cores are necessary to get a representative sample of the reservoir, especially in heterogeneous and vuggy reservoirs. Core sizes are also received in varying lengths, so it is also necessary to allow for different diameter and length cores. The apparatus was designed for core diameters of 4", 1.5", and 1". The core holders must be loaded horizontally, but flooded vertically. Gravity effects, especially at low flow rates, can cause unrealistic dissolution and fluid density separation.

#### *1.4.6 Additional Design Considerations*

Safety is a main design consideration. It was important to include a maneuvering system for the large, 4" X 20" core holder. There are covered discharge tanks and the main equipment is at eye level with valve manipulation in reachable areas. The frame has a drop down plastic sheet and there is physical separation of the expensive components from acid deterioration. All the tubing is tacked down as much as possible to stay out of the way of the operator. The components were also placed to minimize the length of the tubing to limit dead volume. The system was designed to balance the ease of use for the operator while limiting contamination of fluid lines with the use of 3-way ball valves. It is also desired to minimize the lab footprint, make the apparatus flexible to modification and transportable.

### 1.5 Objective and Approach

The objective of the work is to design, assemble and provide thorough documentation of the procedure and equipment for subsequent users. The steps to complete the project included learning to use the old matrix acidizing apparatus and interviewing users to gather best techniques and recommendations for improvement. Next, a list of all components was compiled and research was performed to understand the application of each component to find the best options available to purchase and design the apparatus. Once the vendors were found, bids were collected and orders placed. The apparatus was then assembled and preliminary experiments were performed to ensure functionality. A computer code was written in LabVIEW graphical programming language to monitor and record the laboratory parameters as well as control heaters.

## CHAPTER II

### EQUIPMENT DESCRIPTION AND INITIAL ASSEMBLY

#### 2.1 Equipment Summary

A basic core flooding set up has a core holder, overburden pump, injection pump, accumulator, pressure gauges, and a back pressure regulator (BPR). The components are connected with tubing, valves, and unions. Heaters are used to heat both the fluid and core. Data acquisition components are necessary to monitor and record the pressure drop across the core and temperature. The entire apparatus is mounted on a frame system with components strategically placed considering flow direction and ease of use. The following chapter describes the equipment and assembly of the components installed in the core flooding system. All components are rated to the overall design condition of 5000 psi and 250 deg F. Table 2.1 contains the main components and vendors. The following is a list of the main components that will be described in this chapter:

1. Core holders
2. Overburden pressure pump
3. Injection syringe pump
4. Accumulators
5. Refill tank
6. Pressure Transducers
7. Back pressure regulator
8. Pressure gauges
9. Heating System
10. Valves
11. Unions and fittings
12. Tubing
13. Frame and maneuvering system

TABLE 2.1—MAIN COMPONENTS AND VENDORS									
<u>Item</u>	<u>Material</u>	<u>Pressure Limit (psi)</u>	<u>Temperature Limit (F)</u>	<u>Fitting Type</u>	<u>Fitting Size</u>	<u>Vendor</u>	<u>Part No.</u>	<u>Quantity</u>	<u>Unit Price 2011</u>
Back Pressure Regulator	SS 316	6000 psig	464	FNPT (3)	1/4"	Circle Seal	BPR21U22172	1	3143.65
Piston Accumulator 1	HC276	5000 psi	300	FNPT (2)	1/8"	Phoenix Instruments	TAM-PA-H-1L-5k	1	5075.00
Piston Accumulator 2	SS 316	5000 psi	300	FNPT (2)	1/8"	Phoenix Instruments	TAM-PA-SS-1L-5k	1	3850.00
Hassler Type Core holder	SS 316	5000 psi	300	FNPT (2)	1/8"	Phoenix Instruments	TAM-HAS-1.5x20-H-5k	1	6850.00
Spare Viton Sleeve (1.5"x20", 1"x6", 4"x20")	Viton	*	300			Phoenix Instruments	TAM-HAS-1.5x20-5k-S	3	750.00
Hassler Core Spacer, Ring	SS 316	*	300			Phoenix Instruments		1	570.00
Hassler Type Core holder	SS 316	5000 psi	300	FNPT (2)	1/8"	Phoenix Instruments	TAM-HAS-1x6-H-5k	1	4750.00
Hassler Core Spacer, Ring	SS 316	*	300			Phoenix Instruments		1	260.00
Hassler Type Core Holder	SS 316	5000 psi	300	FNPT (2)	1/8"	Phoenix Instruments	TAM-HAS-4x20-H-5k	1	7850.00
Hassler Core Spacer, Ring	SS 316	*	300			Phoenix Instruments		1	755.00
Clear PVC Plastic Accumulator	Plastic	100 psi				Phoenix Instruments		1	475.00
Pressure Transducer 1		10-300 psi		FNPT (2)	1/4"	Andon Spec	IDP10-A26D11F-M1	1	1548.16
Pressure Transducer 2		100-3000 psi		FNPT (2)	1/4"	Andon Spec	IDP10-A26E11F-M1	1	1612.46
Syringe pump		7500 psi	104			Teledyne Isco	260D	2	
Pressure Gauge-AWC-WIKA	SS 316	6000	212	MNPT	1/4"	AWC	WK 4283034	8	84.25
Ball Valve	SS 316	5000	200	Swagelok*	1/8"	Swagelok	SS-83PS2	6	266.00
Ball Valve	SS 316	5000	200	Swagelok*	1/4"	Swagelok	SS-83PS4	8	215.00
2-way trunion	HC276	15000		AF2	1/8"	HIP Eq	15-71AF2-HC276	1	1555.00
3-way-180	HC276	15000		AF2	1/8"	HIP Eq	15-72AF2-HC276	2	1665.00
3-way-180	HC276	10000		AF4	1/4"	HIP Eq	10-72AF4-HC276	1	1665.00
2-way trunion	SS 316	15000		AF2	1/8"	HIP Eq	15-71AF2	3	280.00
3-way-180	SS 316	15000		AF2	1/8"	HIP Eq	15-72AF2	4	306.00
Relief Valve	SS 316	15000		AF2	1/8"	HIP Eq	15-11AF2	2	102.00
Overburden Pump Enerpac P-392		10000 psi		FNPT	3/8"	Grainger	P-392	1	424.50
Nitrogen Gas Tank		3000 psi			T	AOC		2	90.00
Custom Frame	Aluminum					Industrial Machine		1	3500.00

## 2.2 Fluid Flow and Schematics

Figure 2.1 is the apparatus schematic. The injection fluid, acid or brine, is poured in to the refill tank. The laboratory air source pushes the injection fluid to the bottom side of the piston accumulator. When the bottom side of the accumulator is filled with injection fluid, the syringe pump injects hydraulic oil in to the upper side of the accumulator and pushes the piston down causing a steady flow of the injection fluid to proceed through the heating coil and into the core holder. The spent acid or brine at the outlet of the core holder passes through a back pressure regulator, which holds a pressure at the core outlet, and the fluid that passes through it is collected in a beaker. There is an additional core inlet and outlet tube which is connected to pressure transducers to measure and record the pressure drop across the core holder. A port on the side of the core holder is connected to a hydraulic pump used to apply surrounding pressure on the core. Inlet and outlet terminology refer to the flow direction during core injection. For the accumulator, the inlet is the top and outlet is the bottom since flow direction during core injection is down. Oppositely, the inlet of the core holders are on the bottom and outlet is on top since the flow during injection goes up.

There are 5 main valve series arranged to minimize the necessity to make new connections: Injection Pump Valve Series, Accumulator Valve Series, Core Inlet Valve Series, BPR/Core Outlet Valve Series, and Pressure Transducer Valve Series (Fig 2.2). The correct position of these valve series are described during each operation in Chapter 4. The Injection Pump Valve Series is connected to the injection pump, accumulators and an air release. Manipulation of these occurs while injecting or refilling accumulators and only hydraulic oil goes through these tubes. The Accumulator Valve Series connects to the Hastelloy and stainless steel accumulators and the refill tank. Three way ball valves aide in the ease to switch between accumulators for refill and core injection. With the Core Inlet Valve Series, it is possible to easily switch from injecting in either the large core holder or small core holder and release air before core injection. The Pressure Transducer Valve Series indicates which core holder and pressure transducer is being used. The BPR/Core Outlet Valve Series indicates which core holder the back pressure should be applied as well as allows the tubing at the core outlet to be filled with fluid before core injection.

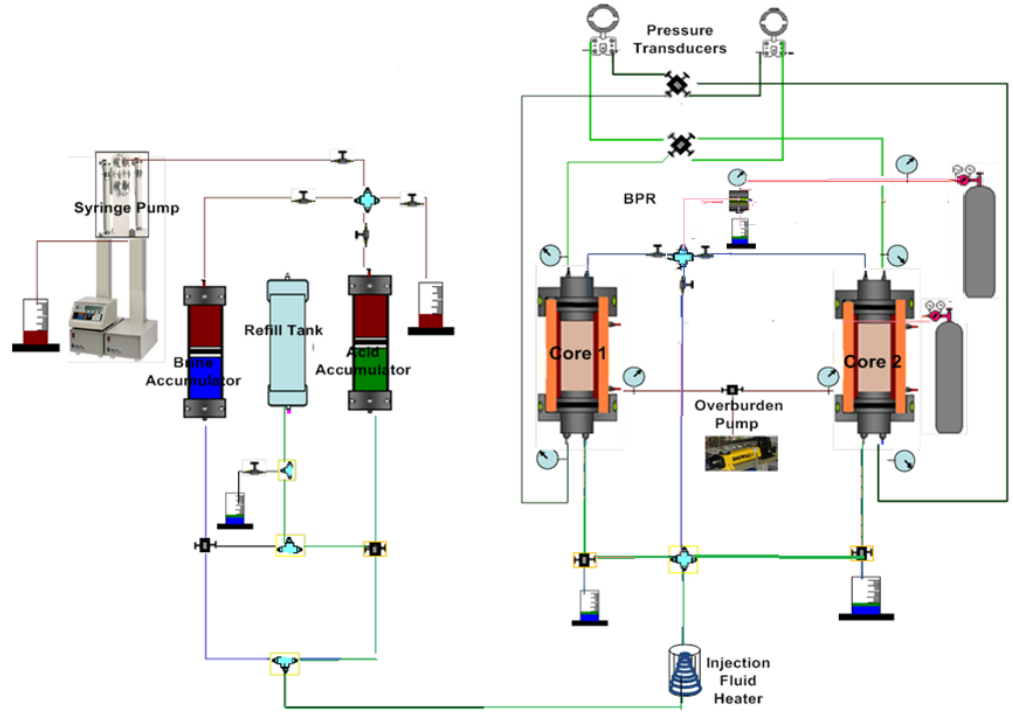

Fig 2.1-- Matrix acidizing schematic for outlet fluid fill

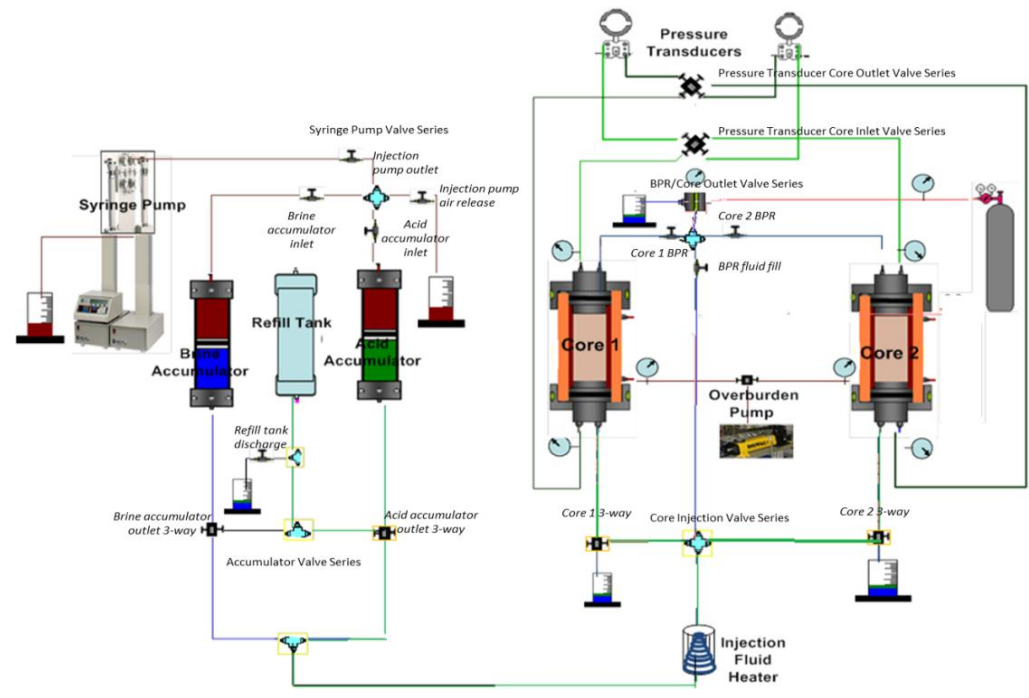

Fig 2.2-- Matrix acidizing schematic with valve series labeled

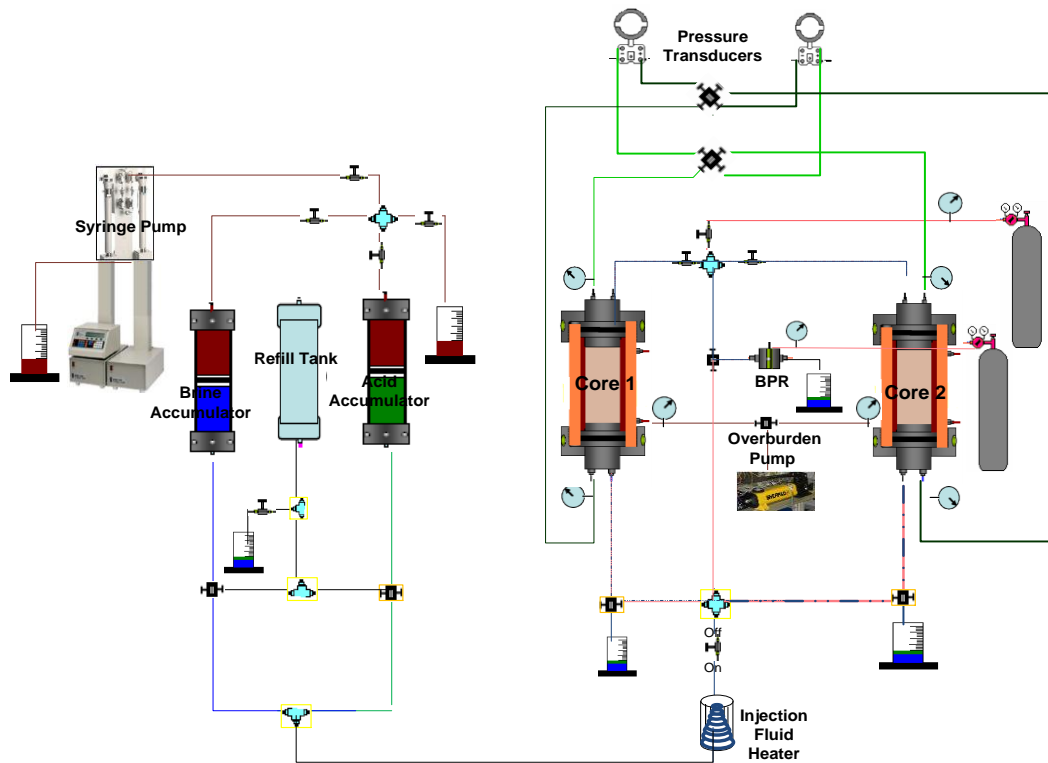

Fig 2.3-- Matrix acidizing schematic for gas flow back

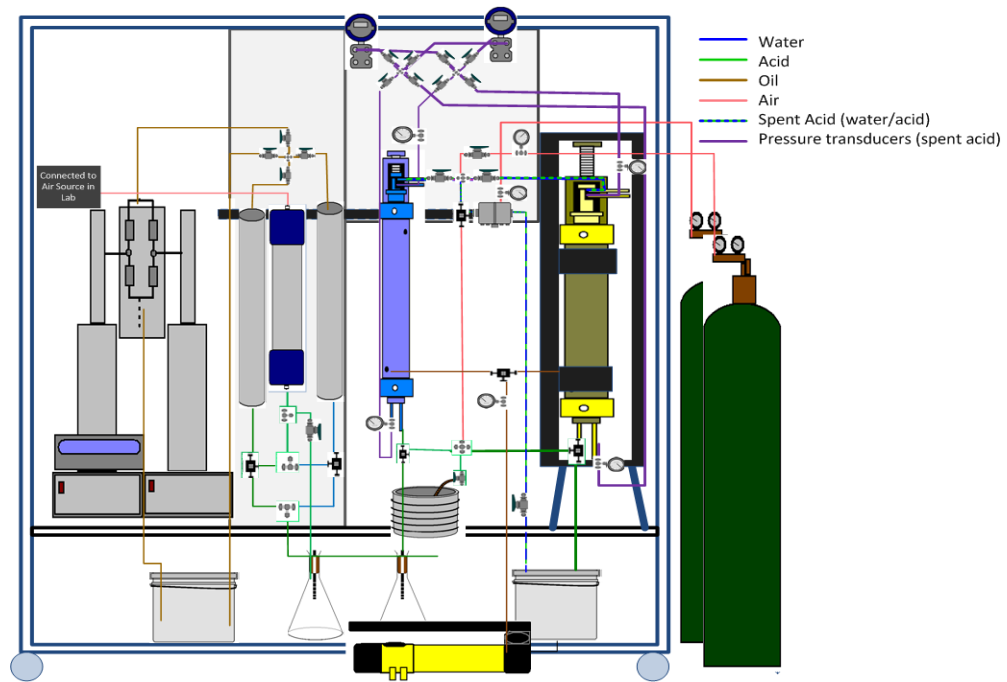
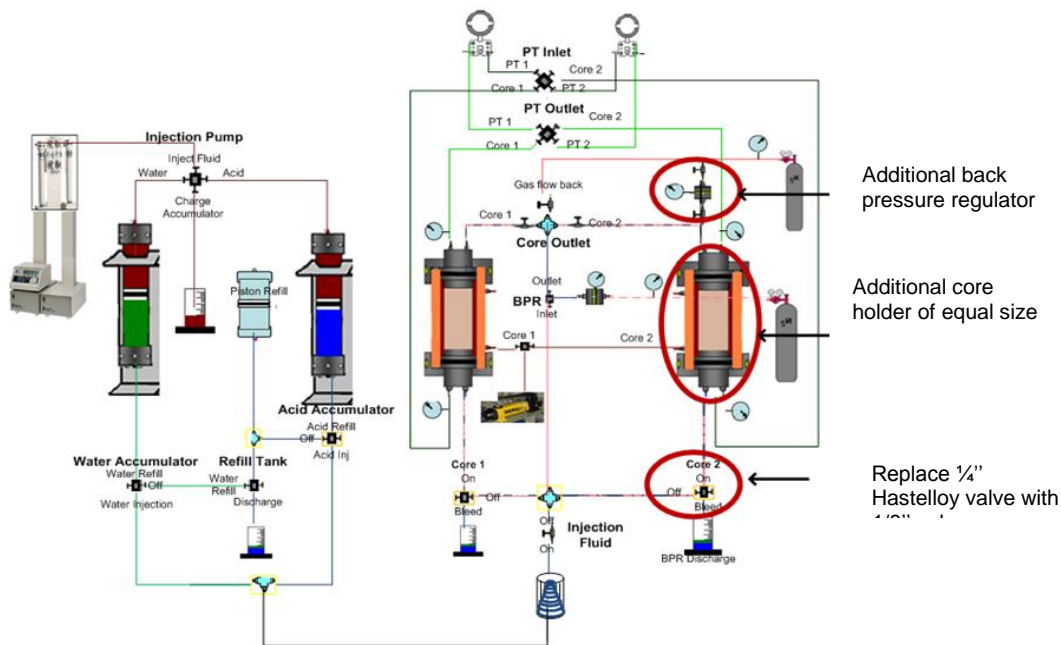

Fig 2.4-- Matrix acidizing schematic with frame



The apparatus was also designed to allow for gas flow back and dual core floods with minor manipulation (Fig 2.3). The gas flow back is used when it is necessary to simulate gas flow from the reservoir after the wormhole has been created. Since the wormhole is created from the bottom of the core vertically upward, the gas source is applied at the top of the core holder and flows from the top down. The valve system is manipulated such that the back pressure is applied on the bottom side of the core holder. However, it would eliminate the ability to fill the back pressure line with brine prior to injection through the core with valve manipulation alone. To flow gas through the core, the *BPR-core outlet* 3-way ball valve should be rearranged such that the bottom of the valve is connected to the BPR. Figure 2.4 is a schematic showing placement of components within a frame.

In order to perform dual core floods, there must be additional equipment. It is recommended to get an additional core holder of equal size. There is also the need for an additional back pressure regulator and either a reducing union or another Hastelloy valve. Fig 2.5 shows the location of the additional equipment. The secondary nitrogen tank used during gas flow back experiments can be used as the gas source for the second back pressure regulator. Also, the Injection Valve Series is set up such that the user can just leave both valves in the open position for fluid to go through each core. Dual core floods are valuable when wanting to investigate effects of diverters for permeability differences in rocks.



**Fig 2.5-- Matrix acidizing schematic for dual core flood**

### 2.3 Core Holders

The core holder is the cell in which the core is inserted, confining pressure is applied, and fluids are allowed to pass through it. The core sample is inserted in the end of the metal, Hastelloy C276, cylinder which is surrounded by a Viton sleeve. The Hassler type core holder is rated to 5000 psi and a temperature rating of 300 deg F . There are 3 different sized core holders which are referenced by the maximum diameter and length of core that can be inserted. A 1'' X 6'' core holder, 1.5'' X 20'' core holder and a 4'' X 20'' core holder are pictured in Fig 2.6 with outer measurements in Fig 2.7. Spacers were also received to allow variable lengths. The core holders with 20'' length have a 6'' spacer, two 3'' spacers and a 2'' spacer allowing for core lengths of 6'', 12'', and 18''. The 6'' core holder has a 3'' and 2'' spacer allowing core lengths of 4'', 3'', or 1''.

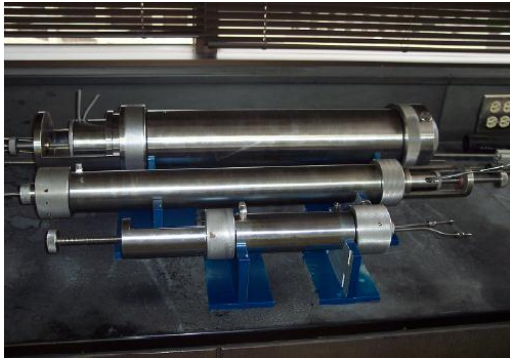

**Fig 2.6—Core holders. From top to bottom: 4" X 20", 1.5" X 20", 1" X 6"**

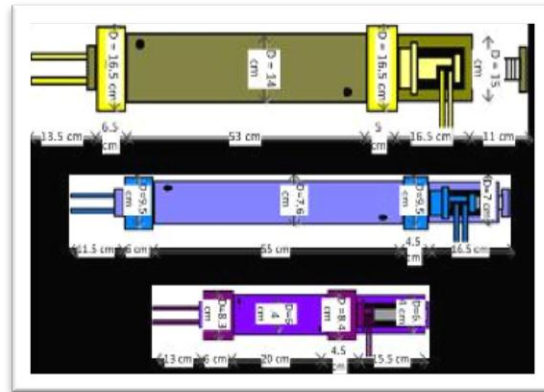

**Fig 2.7—Core holder dimensions**

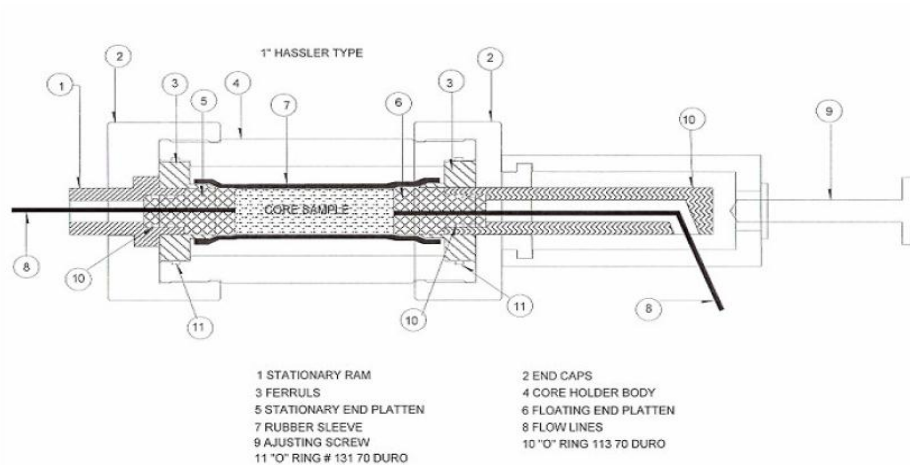

**Fig 2.8—Hassler type core holder diagram**

Fig 2.8 is a manufacturer figure depicting the subassembly and main assembly of the core holder. The subassembly, which remains assembled unless repairs need to be made, consists of 2 ferrules, 2 O-rings, 2 end caps, and a rubber Viton sleeve. The main assembly consists of the floating platen, stationary platen, and adjusting screw which is disassembled and reassembled each time a different core is inserted.

The core holder has 2 inlet and 2 outlet 1/8" tubing lines. One inlet and one outlet tube is connected to pressure transducers in order to measure and record the pressure drop throughout an experiment. The other inlet and outlet tube allows the fluid to be injected and pass through the core. One eighth inch straight unions can be used to extend and connect to the other tubing lines.

There are two 1/8" Female NPT ports on the outer surface of the cylinder. One allows oil to be pumped between the exterior cylinder and Viton sleeve to apply pressure to the rock. A second 1/8" NPT port is connected to a needle or relief valve to release this oil when the rock is being heated or at the end of an experiment. When the core holder is mounted vertically, the port connected to the overburden pump should be on the bottom and the port with the oil release valve should be at the top. This way, when pumping the overburden oil, air that may have got between the Viton sleeve and metal cylinder can be released through the top valve.

#### 2.4 Overburden Pump

Overburden pressure is applied using ENERPAC- 392 hand pump with a maximum pressure of 10,000 psi and 900mL capacity (Fig. 2.9) . The hand pump is used to pump motor oil between the Viton sleeve and metal cylinder of the core holder. This confining pressure simulates down hole field conditions and must be kept a minimum of 300 psi above injection pressure in order to ensure the fluid passes through and not around the core. This requires continual monitoring of the injection pressure while build up is occurring during the first part of the experiment.

There is a 3/8" Female- NPT fitting on the end of the ENERPAC pump, so it is necessary to insert a stainless steel 3/8" - 1/8" Swagelock reducing union to connect the stainless steel tubing. The tubing is then connected to a 3-way ball valve which allows the oil to be pumped to Core 1 (yellow handle to the right) or Core 1 (yellow handle to the left). The tubing from the 3-way ball valve is connected to a pressure gauge and then to the bottom 1/8" port protruding from the surface of the core holder cylinder. To refill the overburden pump, open the cap on the top of the pump and pour in 15W-40 motor oil.



**Fig 2.9 – Overburden pump. ENERPAC hydraulic hand pump is used to apply confining pressure on the core.**

## 2.5 Injection Pump

The Teledyne ISCO high precision- high pressure syringe pump is used to control the flow rate of the fluid being injected in to the core. It is a Dual-pump Continuous Flow 260D Teledyne ISCO Syringe Pump with 7,500 psi maximum pressure (Fig 2.10). It consists of two- 260 mL pumps in which one can refill as the other is injecting creating a continuous fluid stream. There is a digital control panel that the user can set to pump at a constant pressure or, more commonly, constant flow rate. The controller displays volume, flow rate and pressure. The maximum flow rate for the injection pump is 107 mL/min. However, in order to run a continuous stream, the refill rate must be 2 times the injection rate. Therefore, the maximum flow rate to inject continuously is 50 mL/min. The minimum flow rate is 0.001 mL/min. It is important to ensure that there is enough oil volume in the reservoir while injecting for the length of the entire injection. The injection volume is limited by the volume of the accumulators, 1 Liter.

The continuous flow system has a series of Hi Pressure valves that are received already connected (Fig 2.11). The electric valve series is plugged in to and operated by the provided controller. A 1/8" straight union is used to connect the syringe pump tubing outlet to the accumulators. The plastic tube at the lower end of the electric valve system dips into the hydraulic oil reservoir. Hydraulic mineral oil is used through the piston pump which is beneficial long term to reduce corrosion and wear as compared to water, though water can be used.

Each pump needs to be connected to the serial port on the back of the controller. The pump to the right is connected to the top, pump A serial port and pump on the left is connected to middle, pump B serial port. The electric valve system is connected to the controller which is also plugged in to the wall outlet. Each pump is individually plugged in to the wall outlet as well. The tubing coming from the top of the pump is connected to a stainless steel union cross with 2 accumulators and an air release on the other ends.



**Fig 2.10– Syringe pump.  
Continuous Flow 260D Teledyne  
ISCO Dual Syringe Pump and  
controller**



**Fig 2.11 – Syringe pump  
with electric valve system**

## 2.6 Accumulators

A hydraulic accumulator is the metal cylinder with a piston on the inside used to separate the hydraulic oil on top and injection fluid on the bottom. Accumulators are commonly used in hydraulic systems to protect the pump from flow back and absorb any unforeseen pressure surges. They also reduce wear on the pump from corrosive fluids and are less expensive to replace if necessary. There are two hydraulic accumulators in the apparatus, one made from stainless steel for brine injection and the other made of Hastelloy for the hydrochloric acid injection (Fig 2.12). Both have a capacity of 1L, a pressure rating of 5000psi, and temperature rating of 300 deg F. The accumulators account for the overall volume restriction of 1L for a single continuous experiment.

When the accumulators are being refilled, the 3-way ball valve is opened in the correct direction for flow from the refill tank. The air pressure from lab air source pushes the refill fluid into the accumulator raising the piston inside the accumulator. When injecting in to the core, the hydraulic oil from the syringe pump pushes the piston down at a constant rate.

Both accumulators are vertically mounted with the stainless steel accumulator on the left and Hastelloy accumulator on the right. There is a female 1/8" NPT on the top and bottom surfaces of the cylinder. Connect a 1/8" Male NPT- Swagelok fitting to the top and bottom port on the stainless steel accumulator and top of the Hastelloy accumulator. A 1/8" Male NPT-Gyrolok Hastelloy fitting is used on the bottom of the Hastelloy accumulator since the acid will only contact the bottom side. The stainless steel tube



coming from the top of the accumulators connects to the union cross of the Injection Pump Valve Series.

The stainless steel union cross attaches to the injection pump on the top, stainless steel accumulator on the right, Hastelloy accumulator on the bottom, and a discharge valve on the right. The discharge valve is opened when the injection pump is first turned on to ensure no air goes in to the top of the accumulator. It is also opened when refilling the accumulators. The tubes from the bottom of the accumulators are connected to Hi Pressure, three way valves. In the Accumulator Valve Series, the bottom port of the 3-way ball valves connects to the accumulator. This allows fluid flow from the refill tank to the accumulator, from the accumulator to the fluid heater, or “off” when the other accumulator is being used. For the stainless steel accumulator, which is on the left side, the direction of the yellow handle for refill should be left and right for core injection. These valve positions are opposite for the Hastelloy accumulator mounted on the right.

## 2.7 Refill Tank

The refill tank is a PVC plastic clear cylinder with a pressure rating of 100 psi and 1L capacity. PVC is resistant to acid corrosion. The refill container is a safer method than unscrewing the accumulator lids which can cause a lot of wear to the lid. There is a screw on the top surface which is removed to refill with water or acid through a funnel. There is a fluid line connection which protrudes horizontally from the top and bottom of the end caps. The top and bottom were received with Swagelok fittings. The hose from the laboratory air source connects to the top end cap of the PVC container. The bottom tubing is connected to a stainless steel Swagelok union tee with a two way ball valve that is opened when expelling the refill tank. The bottom is connected the Accumulator Valve Series

Note: the air source from the valve does not automatically shut off. When turning the valve from the air source, open it about 45deg and turn it off when there is ~2 in. of fluid left in the tank. Open the two-way ball valve to release any extra pressure in the tank, though if following above instructions, the fluid will not violently squirt out.

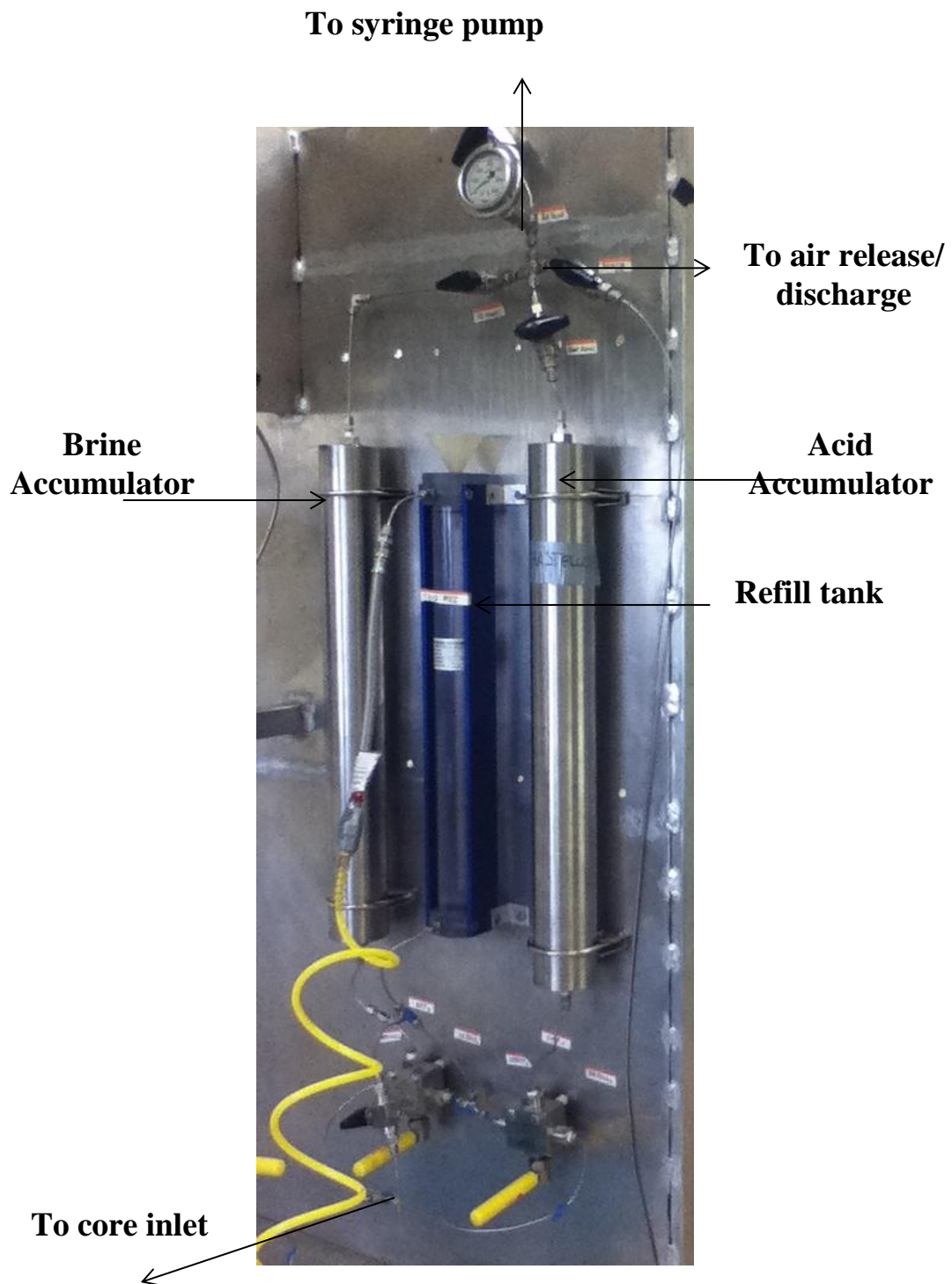
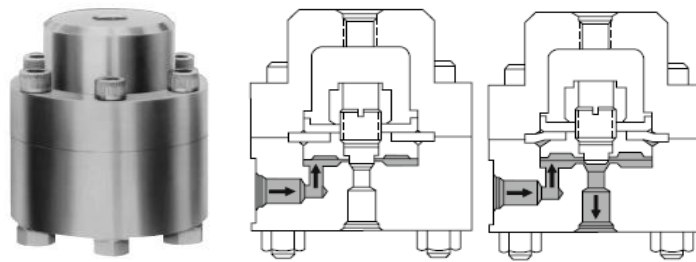

Fig 2.12–Accumulators and refill tank

## 2.8 Back Pressure Regulator

The back pressure regulator is used to hold pressure at the outlet of the core. A BPR21 Series from Circle Seal is a high flow dome loaded back pressure regulator with a pressure range of 25-6000 psi. The body construction is stainless steel 316 with Hastelloy seat material, a temperature range of -65-400 °F, a flow coefficient of 0.90, and an orifice diameter of 0.23". It has three ¼" Female NPT ports. The dome port is on top which is connected to the nitrogen tank. The nitrogen tank applies the desired external or "set" pressure on the internal BPR diaphragm which presses upon the poppet to seal and prevent flow (Fig 2.13). The BPR inlet port is on the side of the cylinder and the BPR outlet is on the bottom. When the pressure at the inlet side of the diaphragm, connected to the outlet of the core, increases beyond the applied dome port pressure, the poppet is lifted off its seat and the fluid is relieved through BPR outlet. This causes a decrease in the inlet pressure and the poppet returns to its closed position, thus maintaining the desired "set" pressure level.

Three, stainless steel ¼" male NPT to 1/8" Swagelok reducing unions are used to connect to the stainless steel tubing at each port. The inlet is connected to a stainless steel union cross. The top port is first connected to a 1/8" union T with a pressure gauge and then leads to the nitrogen tank. The BPR outlet on the bottom of the regulator valve has tubing opening into a discharge beaker. Careful consideration should be made for unconsolidated rocks in which sand grains can get carried with the fluid stream and get caught in the dome ruining the BPR.

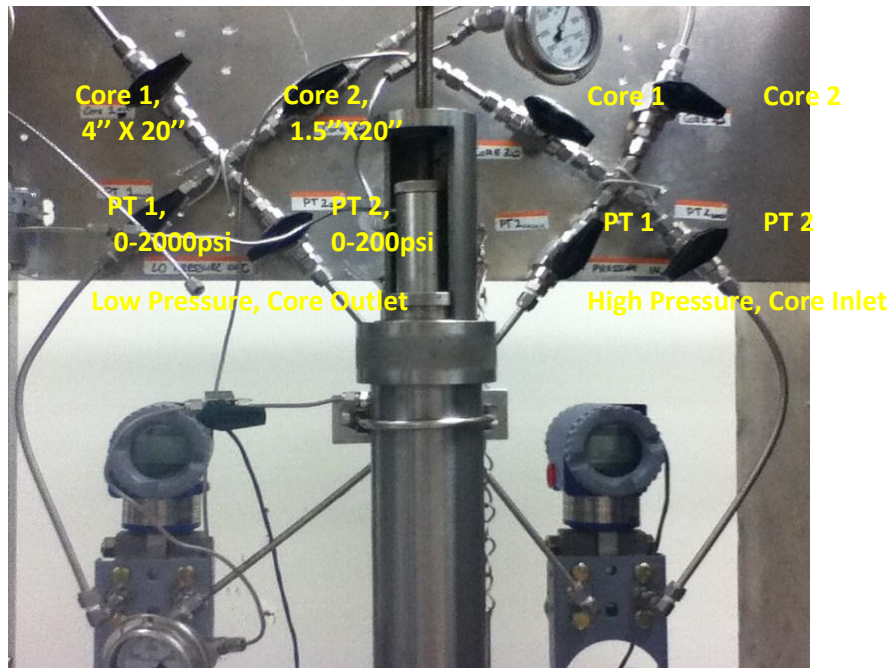

**Fig 2.13–Back pressure regulator. Circle Seal BPR 21 Series. Internal structure is shown when inlet pressure is below set dome pressure(middle) and inlet pressure is above set dome pressure (right)**

## 2.9 Pressure Transducers

There are two Foxboro differential pressure transducers. One with a factory calibrated range of 0-2000psi (PT 1) model IDP10-A26EF-M1 and the second is calibrated from 0-200psi (PT 2), model IDP10-A26D11F-M1. The pressure transducers have an accuracy of +/- 0.06%. To be more accurate with lower permeability cores, PT2 should be used with it's lower calibration range. The pressure transducers work by measuring the difference between the pressures at the 2 separate ¼” NPT connector terminals. The pressure difference is then displayed on the LCD indicator panel which has Silicone fill fluid, a Hastelloy C sensor, and a 316SS process cover. The cover can be removed to reveal the pushbuttons for calibration and configuration described in the manual. Wires from the back of the pressure transducers connect to the National Instruments pin out board which is read by the NI PCI 6221 DAQ card inside the computer and accessed using the LabVIEW program.

The pressure transducers have a ¼” NPT port, so it is necessary to connect a ¼” elbow union to each of the ports since ¼” tubing does not bend. The valve system connected to the pressure transducers allows the flexibility to record delta P from Core 1 or Core 2 using PT 1 or PT 2 depending upon the permeability range. All valves and unions associated with the pressure transducers are stainless steel since the fluid is either water or spent acid. However, be sure to flush these lines with pure water periodically to avoid corrosion. The pressure transducers have a high pressure port connected to the inlet of the core and low pressure port connected to the outlet of the core. The valve system is organized with a high pressure-core inlet ¼” cross union and a low pressure-core outlet ¼” cross union. When performing a single core flood, the valves for the same core and pressure transducer is “on” in both cross unions and all other ball valve are “off.” Fig. 2.14 is an example of the correct configuration for core 2, 1.5” X 20” core holder, and pressure transducer 1, 0-2000psi.



**Fig 2.14–Pressure transducers with valve series**

### 2.10 Pressure Gauges

The pressure gauges throughout the apparatus are WIKA Instrument Corp Model 233.55 Panel Builder Gauge (Fig 2.15). They are composed of all stainless steel metal parts with a pressure range of 0-6000psi. There is a ¼” Male NPT back mount and glycerin filled case with a safety glass window. To connect the pressure gauge to the tubing, a ¼” FNPT-1/8” Swagelok stainless steel straight union is necessary. The straight union is connected to a stainless steel union T in all cases.

There are 8 pressure gauges used in various locations throughout the apparatus to measure the tubing pressure. They are located at the inlet and outlet of both core holders, the outlet of the injection pump, the outlet of the overburden pump, and the top of back

pressure regulator. They are essential for safety, finding leak locations, and observing pressure increases during an experiment.



**Fig 2.15– Pressure gauges**

### 2.11 Heaters

Individual heating elements are used to heat the core and fluid. The options researched for the heating system included an oven, mica band heaters, heating blankets, and heating tape. An oven was ruled out due to the size required for horizontal and vertical position of the 4''X20'' core holder as well as necessity for apparatus transportation. A mica band heater is used for the fluid heater, but not used for the core holder. Since the longest length for a band heater with a 4'' diameter is 10 inches, the largest core holder would require multiple heaters complicating heat distribution and control. The cores are heating using heating tape since, as compared to the heating blanket, heating tape allows direct contact to the heating element improving heat transfer efficiency. A rough estimate of the energy necessary to heat the core can be calculated from the following heat transfer equation:



$$q = m (\Delta T) \times C_p \quad (2.1)$$

Where  $q$  is the heat transferred,  $m$  is the mass,  $\Delta T$  is change in temperature and  $C_p$  is the specific heat. In English units, the heat required to heat the core holder to reach 250 deg F can be calculated as below:

$$\text{Absorbed heat} = \frac{\text{wt of core (lbs)} \times \text{specific heat of stainless steel} \times \Delta T (\text{degF})}{3.412 \left( \frac{\text{BTU}}{\text{watt} \cdot \text{hr}} \right)} =$$

$$\frac{32 \text{ lbs} \times 0.12 \times (250 - 70) \text{ deg F}}{3.412 \left( \frac{\text{BTU}}{\text{watt} \cdot \text{hr}} \right)} \approx \mathbf{172 \text{ watts/hr}}$$

(2.2)

### 2.11.1 Core Heater

To heat the core, heating tape is wrapped around the core holder and surrounded by insulation. The benefits of the heating tape is that it is a continuous heater which will evenly distribute temperature across the core, allows manipulation around the overburden ports, and is an economic choice for sufficient voltage. A heater with higher voltage is harder to control and does not speed up the heating process. There is a different Amptek Duo Tape for each core holder. The 4'' X 20'' core holder has 16 feet of heating tape rated at 312 watts. The 1.5'' X 20'' core holder has 12 feet of tape with 234 watts and the 1'' X 6'' core holder uses a 6 foot heating tape with 117 watts. All heaters have 120 volts, which is standard voltage to plug in to the US outlet. Fig 2.16 is the heating tape installation guide.

**RECOMMENDED GUIDELINE FOR INSTALLING AMPTEK HEATING TAPE ON PIPE OR TUBING.**

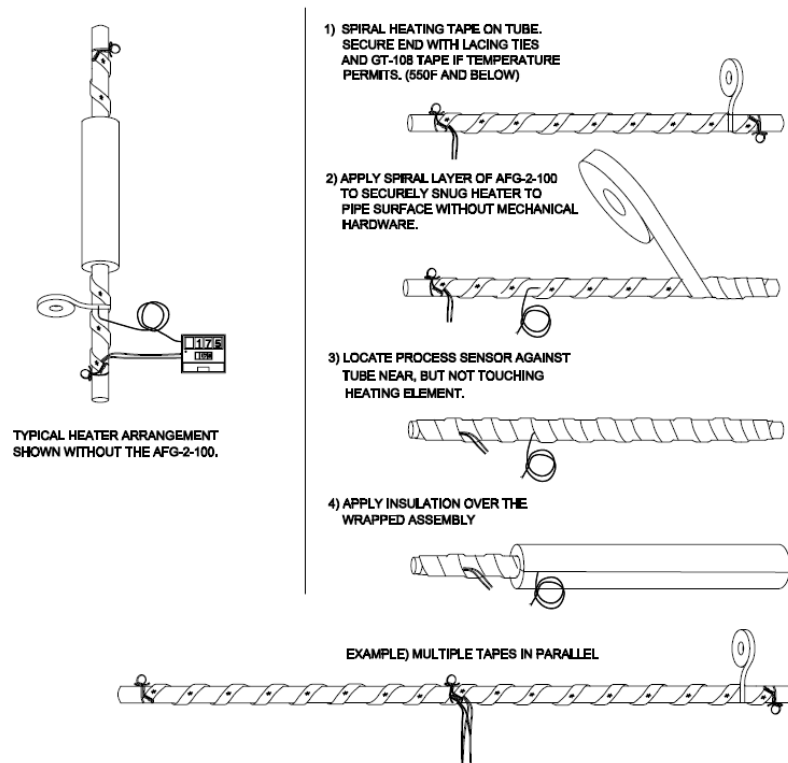

**Fig 2.16– Heating tape assembly. Instructions from AmpTek**

### 2.11.2 Fluid Heater

The fluid heater is simply a mica band heater with the tubing wrapped around the heater contained and insulated as shown in Fig 2.17. The custom system was provided by Delta Manufacturing and more specifically is a 6'' O.D. X 5.5'' wide, 1500 watt, 120V heater with type C ground. The heater is surrounded by a metal pipe, the tubing is wrapped around the metal pipe, and insulation surrounds the tubing as well as inside the heater to conserve as much heat as possible.

The tubing from the outlet of the accumulator valve system connects to the bottom of the fluid band heater. The tubing is wrapped around starting from the bottom going up, so that the tubing coming from the top is connected to the cross union before the injection valve system. It is placed on the base of the frame shelf. There is insulation on the bottom of the heater as well as wrapped around the tubing to minimize heat loss before the fluid enters the core as shown in Fig 2.18.



**Fig 2.17–Fluid heater.  
Components from Delta**

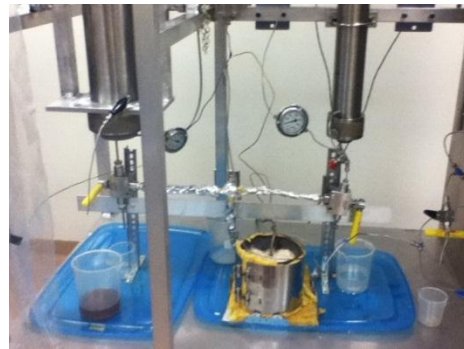

**Fig 2.18–Fluid heater in frame**

### *2.11.3 Thermocouples*

Thermocouples are a common, inexpensive device used for temperature measurement. It consists of two different metals which produce a voltage proportional to a temperature difference between the pair of conductors. There are different types of thermocouples depending on the combination of metal alloys being used which have different temperature ranges and sensitivity. Type J thermocouples has an iron-constantan alloy pair with a range of -40 to 1382 deg F and a sensitivity of 55 ( $\mu\text{V}/\text{deg C}$ ). There are two

purposes for the thermocouples in the system, first to measure the temperature of the rock and heaters to confirm the temperature of the system and the second is to connect to the controller so the controller logic can control whether the heater should be on or off. Since the thermocouple measures the voltage change and not the actual temperature, a base temperature, usually the cold temperature is used as a reference referred to as the Cold Junction Compensation. The thermocouples are plugged in to a National Instruments USB 9221 device to record the temperature which has a CJC thermistor built in.

OMEGA cement-on thermocouples are thermocouples bonded to a thin laminate or carrier which may be adhered to a surface with an epoxy, cement or other adhesive. Cement-on thermocouples feature a thermocouple bead which has been rolled flat to provide rapid response times. It is used primarily for surface temperature measurement as in this case where it is mounted on the exterior of the core holder. A probe thermocouple is used at the outlet of the fluid heater to control and measure the fluid temperature before entering the core. The OMEGA grounded probe thermocouple is connected to the union cross at the outlet of the fluid heater. It has a plug already attached to it which is plugged in to the USB 9221.

#### *2.11.4 Solid State Relay*

A control loop was programmed in LabVIEW to automatically control temperature. The control program utilizes a simple ON/OFF with hysteresis logic to activate the solid state relay. Depending on the set temperature and process variable, the PCI 6221 card will

output a digital signal either on, 5 volts, or off, 0 volts, which is sent to the solid state relay (SSR). The relay then amplifies that voltage which turns on the heater. The type of solid state relay depends on the heater and signal that will be output.

Solid state relays need to be compatible to the total current of the heater and the type of current, alternating or direct. The load side of the SSR connects to the heater and the control side must have suitable current type that is output by the PCI 6221 connector block. The current coming from the NI pin out board is direct current. Two 10 Amp solid state relays are contained in an electrical box which are connected to the pin out board and to the heaters (Fig 2.19).



**Fig 2.19–Solid state relays in electric box**

## 2.12 Valves

The valves used in the apparatus are 2 and 3-way ball valves and a relief valve (Fig 2.20). The 2-way ball valves are either on or off. The 3-way ball valves are beneficial because it allows a diversion of flow without added connections. The relief valve can be set to open at a certain pressure. The temperature, pressure and material vary upon the placement in the apparatus as summarized in Table 2.2.

### *2.12.1 2-way Ball Valves Low Temperature*

Trunion 83 series 2-way ball valves were ordered from Swagelok (Fig 2.21). They are made from stainless steel 316 with a pressure rating of 6000psi at temperatures up to 100 degF. The PEEK seat material in the ball valves limits the working pressure to 5000psi at 200 degF, 4100psi at 250 degF and 3200psi at 300 degF. Therefore, these ball valves are only used in areas that are not required to have both high temperature and high pressure. Eight ¼” 2-way ball valves with Swagelok connections are used in the Pressure Transducer Valve Series. Four 1/8” Swagelok ball valves are used in the Injection Pump Valve Series. The valve is open when the black handle is parallel to the tubing. To obstruct flow, turn the handle 90° so it is perpendicular to the tubing. These valves are convenient since the unions are also Swagelok connections, relatively small and easy to turn.



**Fig 2.20 – Apparatus valves. From left to right: relief valve, 3-way ball valve, 2-way ball valve**



**Fig 2.21 – Swagelok 2-way ball valve interior structure**

### 2.12.2 3-way Ball Valves

Hi Pressure (HiP) Hastelloy 180° 3-way Trunion ball valves are used at the outlet of the HCl accumulator and core inlet (Fig 2.22). Due to the specialized material and small size desired (Hastelloy, 1/8"), the lowest pressure rating available is 15,000psi with a temperature rating of 650degF. Stainless steel 1/8" 180° 3-way ball valves are used for the *overburden valve*, *brine accumulator outlet valve*, and *BPR-core outlet valve* since they will not contact substantial concentrations of acid.

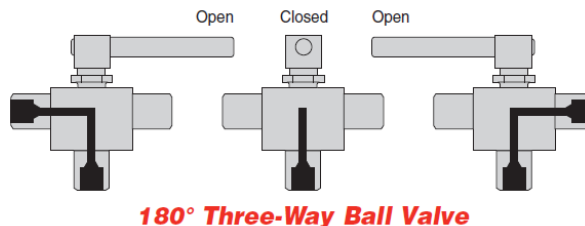
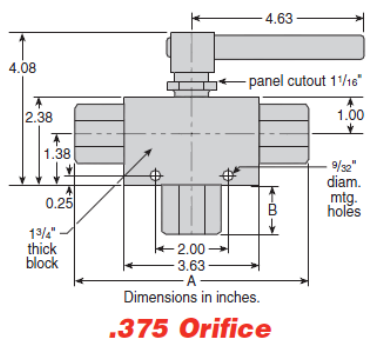

**Fig 2.22 – HiP 180° 3-way ball valve. Dimensions (left) and valve position for desired flow directions (right)**

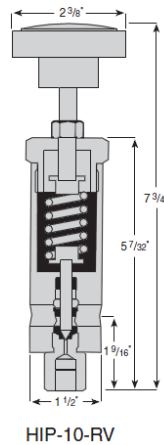

**Fig 2.23 – HiP relief valve dimensions**

### 2.12.3 Relief Valve

A field adjustable relief valve is also ordered from HiP. As the core holder is heated while running an experiment, the volume of given oil mass increases causing the hydraulic pressure to increase. The degree of expansion is expressed as the coefficient of thermal expansion which is the ratio of the relative change of volume to a change in temperature. Considering the coefficient of expansion for motor oil, the volume can increase by about 7% when heated from 70 to 250°F and it is necessary to release this volume of oil. The relief valve is made of stainless steel, has two FNPT 1/4" ports, and a pressure range of 1,000-10,000psi (Fig. 2.23). One 1/8"-1/4" reducing union is connected to the inlet side to connect to the upper port on the 4"X20" core holder. The outlet 1/4" stainless steel tubing discharges into a beaker.



TABLE 2.2-- VALVE LIST						
<u>Valve Placement</u>	<u>Type</u>	<u>Size</u>	<u>Material</u>	<u>Pressure Rating</u>	<u>Temp Rating @ 5000psi (°F)</u>	<u>Manufacturer</u>
<i>Injection Pump Valve Series</i>						
Injection pump outlet	2-way	1/8"	SS 316	6000	200	Swagelok
HCl accumulator inlet (top)	2-way	1/8"	SS 316	6000	200	Swagelok
Brine accumulator inlet (top)	2-way	1/8"	SS 316	6000	200	Swagelok
Air release outlet	2-way	1/8"	SS 316	6000	200	Swagelok
<i>Accumulator Valve Series</i>						
Refill tank	2-way	1/8"	SS 316	6000	200	Swagelok
HCl accumulator outlet (bottom)	3-way	1/8"	Hastelloy	15000	650	HiP
Brine accumulator outlet (bottom)	3-way	1/8"	SS 316	15000	650	HiP
<i>Core Inlet Valve Series</i>						
Core 1 inlet (4" X 20")	3-way	1/4"	Hastelloy	15000	650	HiP
Core 2 inlet (1.5" X 20" or 1" X 6")	3-way	1/8"	Hastelloy	15000	650	HiP
Inlet gas flow back	2-way	1/8"	Hastelloy	15000	650	HiP
<i>Overburden Valve Series</i>						
Overburden pump	3-way	1/8"	SS 316	15000	650	HiP
Relief valve	relief	1/4"	SS 316	10000	650	HiP
<i>Core Outlet/Back Pressure Valve Series</i>						
BPR-core outlet	3-way	1/8"	SS 316	15000	650	HiP
Gas flow back	2-way	1/8"	SS 316	15000	650	HiP
Core 1 outlet (4" X 20")	2-way	1/8"	SS 316	15000	650	HiP
Core 2 outlet (1.5" X 20" or 1" X 6")	2-way	1/8"	SS 316	15000	650	HiP
<i>Low Pressure- Core Outlet, Pressure Transducer Valve Series</i>						
PT1, 0-2000psi	2-way	1/4"	SS 316	6000	200	Swagelok
PT2, 0-200psi	2-way	1/4"	SS 316	6000	200	Swagelok
Core 1 outlet (4" X 20")	2-way	1/4"	SS 316	6000	200	Swagelok
Core 2 outlet (1.5" X 20" or 1" X 6")	2-way	1/4"	SS 316	6000	200	Swagelok
<i>High Pressure-Core Inlet, Pressure Transducer Valve Series</i>						
PT1, 0-2000psi	2-way	1/4"	SS 316	6000	200	Swagelok
PT2, 0-200psi	2-way	1/4"	SS 316	6000	200	Swagelok
Core 1 inlet (4" X 20")	2-way	1/4"	SS 316	6000	200	Swagelok
Core 2 inlet (1.5" X 20" or 1" X 6")	2-way	1/4"	SS 316	6000	200	Swagelok

### 2.13 Tubing

There are 4 combinations of tubing differing in size and material. Hastelloy is used where tubing will carry high concentration of acid. These flow lines are from the refill tank to the accumulators and from the accumulators to the core injection. Stainless steel 316 is used for all other flow lines. There are two different sizes of tubing used, ¼” and 1/8”. The ¼” tubing is used for flow lines attached to the 4” X 20” core holder. The 1/4” tubing are also used for the valve series connected to the pressure transducers since they are only available with ¼” NPT ports. Eighth inch tubing is used for all other flow lines. The benefit of 1/8” tubing is that it is easy to bend especially when spiraling around the fluid heater. However, it is also more susceptible to bends that can be difficult to straighten out. This is especially problematic since the tubing has to align perfectly into the valve connections to prevent leaks at high pressure. The ¼” tubing is sturdier allowing for better alignment for connections, though is hard to bend requiring elbow unions which create additional opportunity for leaking. The placement of tubing is summarized in Table 2.3.

<u>Outer Diameter</u>	<u>Material</u>	<u>Manufacturer</u>	<u>Location</u>
1/8"	Stainless steel	Swagelok	Injection pump to accumulators, overburden pump, core outlet
1/4"	Stainless steel	Swagelok	Pressure transducer valve series
1/8"	Hastelloy	Vindum	Refill tank to accumulators, accumulators to core injection
1/4"	Hastelloy	Vindum	Injection into 4 X 20" core holder

## 2.14 Fittings and Unions

A fitting is the metal coupling that connects a component to the tubing network. Compression fittings are composed of a nut, a ring, and a ferrule (Fig 2.24). The unions are either a tee union, cross union, elbow union, straight, or reducing union (Fig 2.25). These are various ways to connect the tubing for flow divergence depending on the application.

All of the main components attach to the system using National Pipe Thread (NPT) fitting of various sizes as described in preceding sections. However, NPT is not compression fitting and needs thread seal tape. When optional, 1/8" NPT was ordered since larger NPT sizes have greater leak problems.

There are 3 different compression fittings in the system that have the same type of pieces, though should not be interchanged. Gyrolok ordered from AWC are all the Hastelloy unions and fittings designated with an "H." Swagelok is used for all other unions and fittings in stainless steel and have a "C" imprinted. The high pressure, high temperature valves from HiP use A-lock compression fittings. All components have either a male or female NPT port so it is necessary to get correctly sized NPT –Swagelok (or Gyrolok) unions.

To make a fitting:

- Put a straight, tee or cross union in a vice
- Inspect the 3 components to understand how they fit together. The nut is the largest piece which will be tightened. The ring is the smallest piece with a thick side that fits in the nut and a smaller side that will fit inside the ferrule when aligned. The ferrule is the cone shaped metal piece.
- Slide the nut on to the tubing smooth side first.
- Slide the ring on next thicker diameter side first.
- Slide on the ferrule large diameter side first.
- Align the tubing to match with the hole on the union in the vice.
- Use your hand to turn the nut as much as possible and fit on the union
- Use a wrench for an additional  $\frac{1}{4}$  turn to tighten
- Unscrew the nut and confirm the connection does not come off the end of the tubing

*Tip:* Do not over-tighten, this can shred the pipe



**Fig 2.24 – Compression fittings from Swagelok**



**Fig 2.25 – Unions from Swagelok**

### 2.15 Frame

The frame was designed as one unit which needs to hold all components and allow easy access for the user. The frame is constructed with aluminum, a sturdy material that is less susceptible to corrosion from the hydrochloric acid fumes. It is on rollers so the entire system besides the nitrogen tank and computer, can be easily transported and contained under the fume hood. The overall height and depth dimensions were designed as the minimum lengths to hold the 4'' X 20'' core holder in the horizontal and vertical positions including the distance needed to connect to valves at the core inlet and outlet. The core holder maneuvering system was designed so that the 4'' X 20'' core holder can be loaded horizontally, then rotated to flood vertically. Also, there is space for the rope heater and insulation surrounding the core holder. The smaller core holders are positioned at eye level as well to be taken on and off. Valve positions and pressure transducers were placed for user easy access. High pressure high temperature valves are substantial size and weight. An additional stand, built of steel beams drilled to the base of the main shelf, had to be built at the core inlet. The accumulators and core holders are mounted vertically, and all components were placed to minimize the length of the tubing and limit dead volume. The syringe pump is the most expensive component and therefore is protected by an aluminum wall. Also, the large fluid reservoirs are placed below the shelf so leaks and splashes will be more contained. There are plastic spill catches beneath the core holders to catch any leaks from the core. Figure 2.26 shows the assembled apparatus.

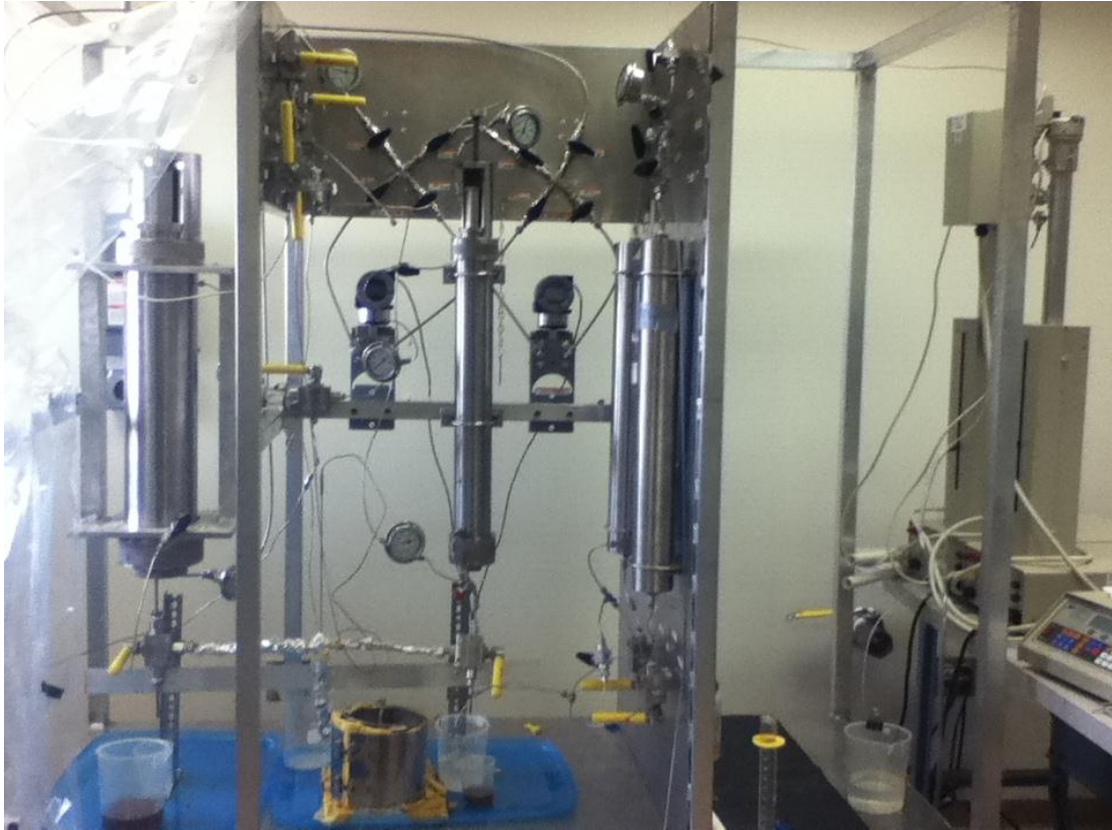
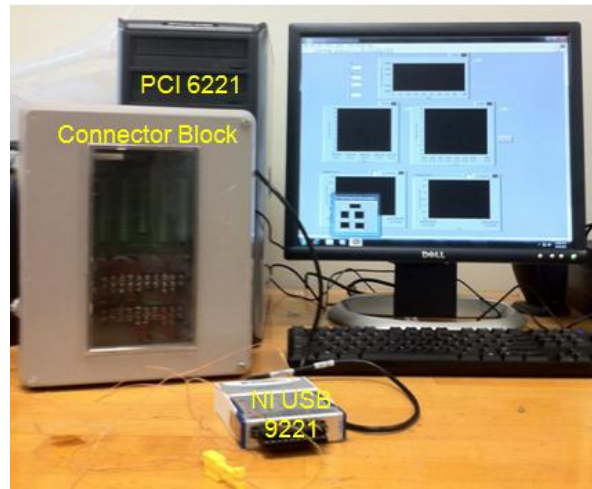

**Fig 2.26 – Assembled apparatus with frame**

## CHAPTER III

### DATA ACQUISITION HARDWARE AND SOFTWARE DESCRIPTION

The following chapter describes the computer hardware and software for measuring and recording pressure and temperature. The data acquisition system records the pressure drop across the core and the temperature of the fluid entering the core and core holder. The pressure is measured with pressure transducers connected to the inlet and outlet of the core holder via tubing. The temperature is measured with a probe thermocouple at the outlet of the fluid system and a cement on thermocouple attached to the surface of the core holder. The thermocouples are attached to a National Instruments USB 9221 device which plugs straight in to the computer's USB port. The pressure transducers are connected to a National Instruments PCI- 6221 DAQ card through the CB-68LP pin out board. Using LabVIEW, National Instrument's graphical programming language, a program was written which reads the data from the devices, graphs the data in real time, and writes the information to an excel spreadsheet for later data analysis. Furthermore, the program includes an on/off heater control programs which, based on the temperature of the thermocouples, turns the heaters on or off via the solid state relays. Components are pictured in Fig. 3.1.

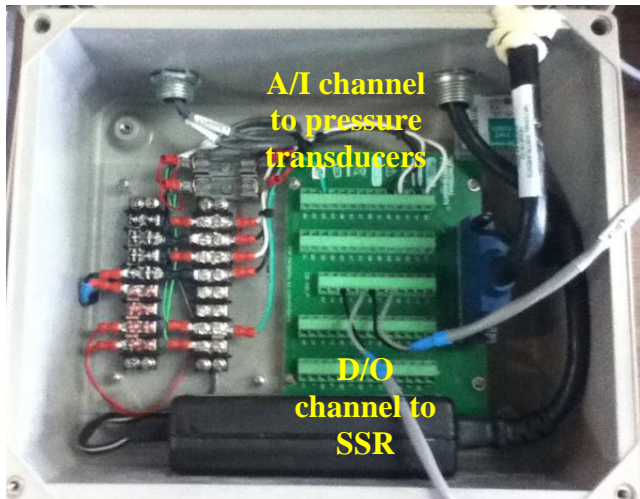

**Fig 3.1--National Instruments hardware and computer**

### 3.1 PCI 6221 DAQ Card and Pin-out Board

The PCI 6221 is the data acquisition card from National Instruments which sends and receives the signals to monitor pressure and control temperature. The PCI 6221 has 68 pins with 16 analog input channels, 2 analog output channels, 24 digital input/output/PFI channels, 2 counter/timers, and one frequency generator (Fig 3.3). One pressure transducer is connected to channel 68 and 34, utilizing the analog differential capability. The other pressure transducer is connected to analog input channels 33 and 66 (Fig 3.2). The analog ground is connected to channel 29. The analog wire channels first go through a set of resistors to dump noise followed by a 1.5 amp fuse. The solid state relays are also connected to the connector block. The fluid heater's clear wire is connected to port 0 line 0 which is channel 52. The black cord, which is the ground, is connected to channel 53. The heating tape cord is connected to port 0 line 0 which is channel 17 with ground 18.





**Fig 3.2 – Electric box with NI pin-out board**

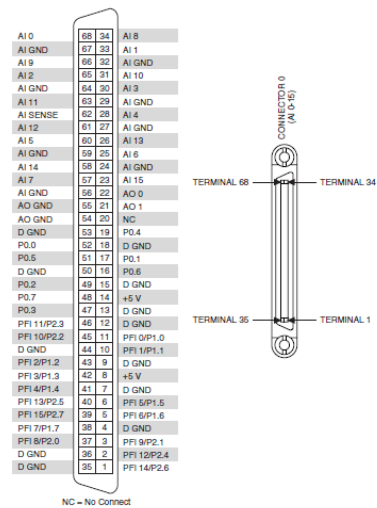

**Fig 3.3 – PCI-6221 68-pin schematic**

### 3.2 USB 9221

The temperature is read using the National Instruments USB 9221 which has 8 single ended analog input channels allowing the connection of 4 thermocouples (Fig 3.4). The thermocouples have a positive and negative wire each transferring an analog signal which is screwed in to the port. The device is easily plugged in to a USB port of the computer. Channel 1 connects to the probe thermocouple at the outlet of the fluid system, channel 2 connects to the cement on thermocouple on the core heater. Since the thermocouple measures a voltage change and not absolute temperature, one junction, usually the cold junction is held at a known temperature. The USB 9221 has a built in thermistor which is a thermally sensitive device acting as the cold junction compensation.



**Fig 3.4 – National Instruments USB 9221**

### 3.3 Software

#### *3.3.1 Measurement and Automation Explorer*

Measurement and Automation Explorer (MAX) is a National Instruments program used to configure the hardware. This program gives the user the capability to first check if the hardware device is working with the computer before investigating programming issues. When a device is installed in the computer, it is automatically comes up in the Measurement and Automation Explorer (MAX) under “devices.” Device 1 is the PCI-6221 device and device 2 is the USB 9221 device. To confirm the device is correctly reading in to the computer:

- High light the device
- Click the “Test Panels” tab
- Click “self-test”

If the hardware is installed correctly, a window appears saying “this device has passed a self-test.” If there is an error, basic solutions can be checking whether the wires from the box have gotten loose or try to restart the computer. It is also possible to create simulated

devices to test VI's and create a calibration scale, which was done for the pressure transducers.

### *3.3.2 LabVIEW Basic Operation*

LabVIEW is a graphical development environment used to create measurement and control systems. The programs are called virtual instruments or VI. There is a front panel, which is the user interface and a back panel, where the code is written. The front panel defines the inputs from the user and shows graphs or indicates the data that is being received.

### *3.3.3 LabVIEW Front Panel*

To run the program, open the "Matrix Acidizing VI." The front panel should appear as shown in Fig 3.5. The top left area in the yellow box is to input core dimensions in the units assigned in order to calculate permeability. Below is the "Pressure Channel Parameters" with drop down menus to select the correct device and channel that the pressure transducers connect to as well as the custom calibration scale created in MAX. These are set as default and should not be changed. Below that are the heater control parameters for the fluid heater and core heater. The user enters the set temperature as well as hysteresis or range of values that is acceptable before the heater is activated. It is recommended to set the temperature to 250 degF and use a hysteresis of 2 deg F. The "Fluid Mode Selection" drop down allows the option to manually override the heat control program while continuing to acquire data while the VI is running. For example, to turn off the heaters, select "Override Off" or "Override On" to keep the heaters on

regardless of what the set temperature and value read by the thermocouple is. The green indicator light will be lit when the heater is on and turns off when the temperature is reached.

The set of graphs to the right of the control inputs in the red box includes temperature versus time on the top and permeability on bottom. The top graph displays all 4 of the thermocouple temperatures though only 2, channels AI0 and AI1, are currently being used for the fluid and core heaters respectively. Two more thermocouples in channel AI2 and AI3 are plugged in case temperature measurements are wanted for other purposes. The permeability graph has two lines, one for the permeability calculated from the 0-200 psi pressure transducer and one calculated from the delta P coming from the 0-2000psi pressure transducers. The green box to the right has the graphs of pressure drop versus time for the 0-200 psi pressure transducer on top and the 0-2000psi pressure transducer on bottom. Only one graph will display the correct pressure drop depending on which is being used in the valve system. The values on the graph should match the values that are displayed on the pressure transducers with minimal error if calibrated correctly. The graphs in the blue box are a visual representation of the fluid temperature on top and core temperature on bottom relative to the set temperature.

With all graphs it is possible to change the x and y scales. To do this, right click the axis wished to be changed, select "properties," select "display format," and change the value in the correct boxes.

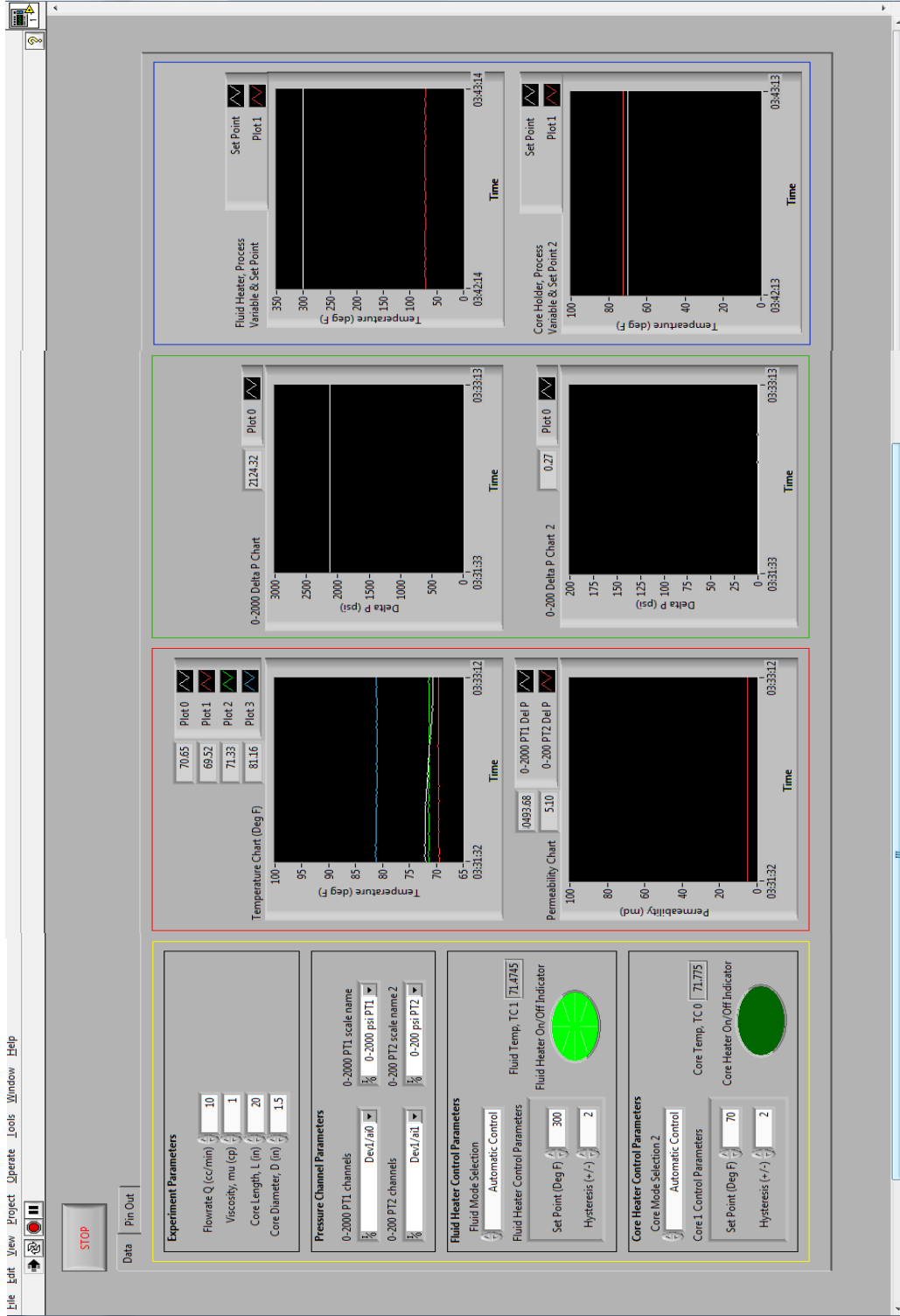

Fig 3.5 – LabVIEW front panel

### 3.3.4 LabVIEW Back Panel

The LabVIEW back panel can be accessed by clicking “Window” in the top ribbon and select “back panel” (Fig 3.6). There are 3 main functions that are performed in the program: monitoring pressure, monitoring temperature, and controlling temperature. The flow of programming goes from left to right connected by the lines. The purple lines carry the task, the orange lines carry data, and yellow lines carry error. The VI is organized such that the icons on the right interact with the external hardware, inside the control loop is the programming logic, and the right side icons clears the tasks and errors.

There are 4 sets of tasks being performed which can be noticed by observing the icons with the red heading and following the purple and yellows lines from left to right. The top set receives the analog input data from the pressure transducer attached to the PCI 6221. Below that is the analog input data received from the thermocouples connected to the USB 9221. The bottom 2 tasks are the temperature control logic which uses the data from the thermocouples, goes through the on/off/hysteresis logic to determine the digital output to send to the solid state relays via the PCI 6221. Each set of tasks have an error line that is attached to a cluster icon that will stop the program if an error occurs. It is possible to determine exactly where the error is in the code by clicking the light bulb button at the top ribbon before selecting the run arrow. This will slow down the program though, so it should not always be left on.

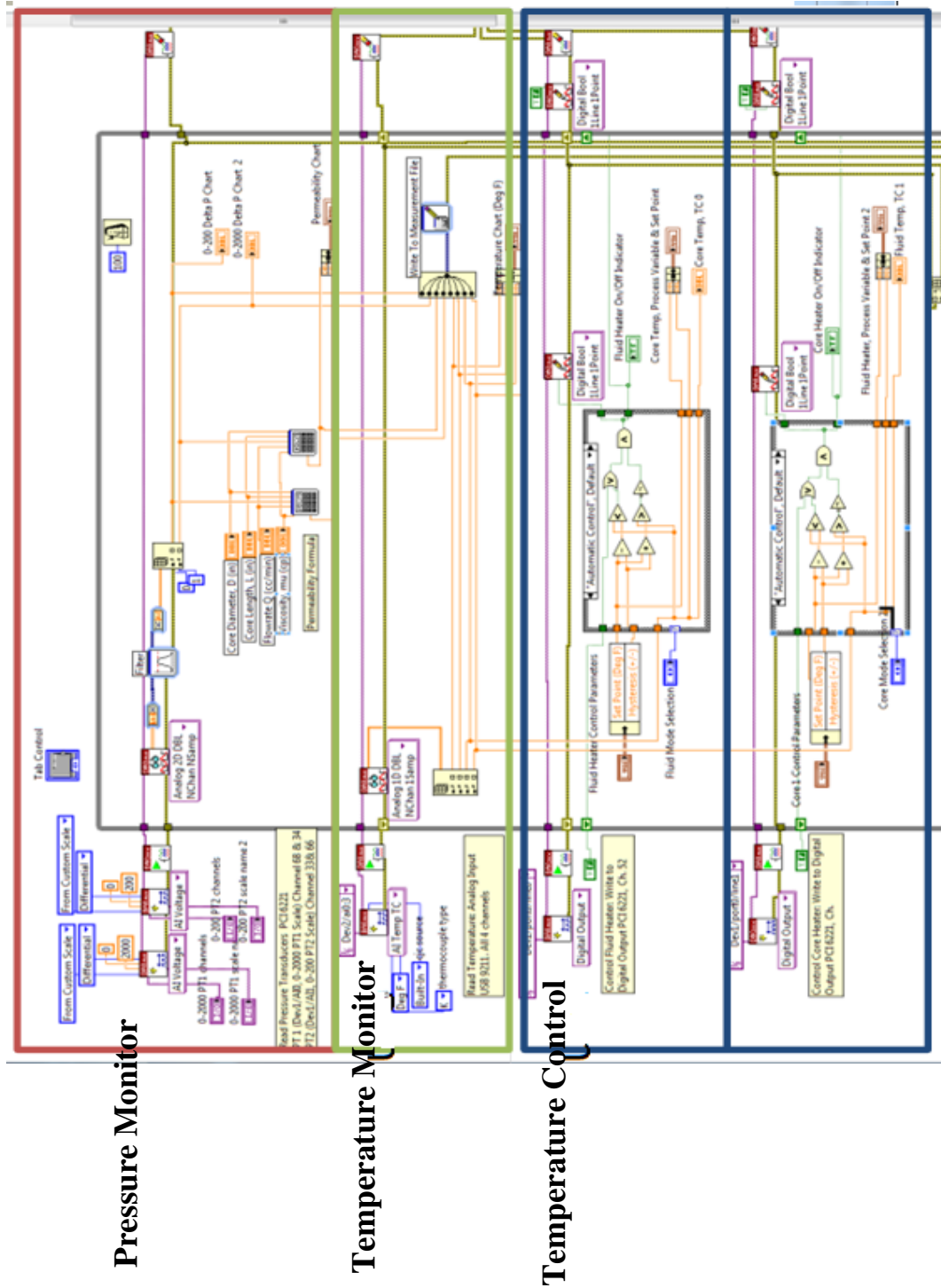

Fig 3.6 – LabVIEW back panel

### *Pressure Monitor*

To monitor pressure the only hardware involved is the PCI 6221. The icon used to call the device hardware is the “create task DAQmx.” The icon on the left is for the 0-2000psi, PT 1 connected to channels 68 & 34. The icon directly right is the 0-200psi PT 2 connected to channel 33 & 66. The signal from the pressure transducers is an analog input voltage which is converted to the pressure using MAX. By hovering the cursor over the edges of the icon, it is possible to create controls for the different parameters characterizing the signal being received by the device. The blue and orange constants are default describing the unit, data type, and minimum and maximum value possible. The purple icon controls appear on the front panel where the user can indicate the channels the pressure transducers are connected to and the custom calibration that was created in MAX. The possible selections appear automatically in a drop down menu. The next icon to the right is the “start task DAQmx” followed by “read DAQmx” specifying the signals from the device are analog inputs, 2 dimensional double. The double is converted to dynamic data in order to filter the data which is converted back to a double. Up to this point, the data line is an array carrying both pressure transducer signals so it is necessary to split the 2 dimensional array in to the individual elements. There are two orange lines coming from the index array function which carry data from only one of the pressure transducers. Following the orange line right connects to an orange icon which is the graph indicator on the front panel.



### *Calculating Permeability vs. Time*

The orange lines containing the pressure transducer data is also connected to the calculator icon (Fig 3.7). By double clicking on the calculator icon, it is possible to see the form of Darcy's Law used to calculate permeability using the appropriate units. Once again, hovering the cursor over the edges of the icon indicate where the other inputs should connect. The other parameters were created as controls input on the front panel. The output of the permeability calculation is connected to a maroon icon which is the graph indicator on the front panel.

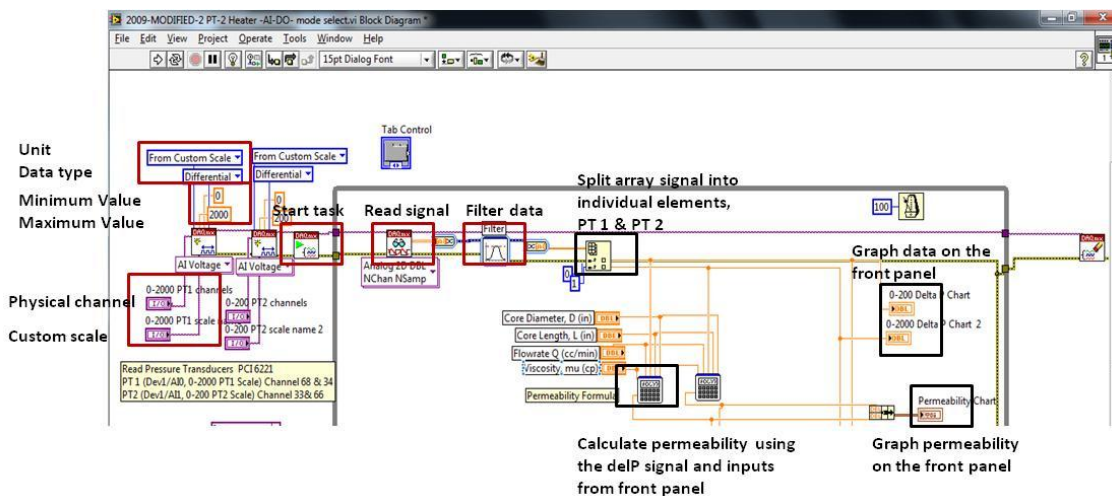
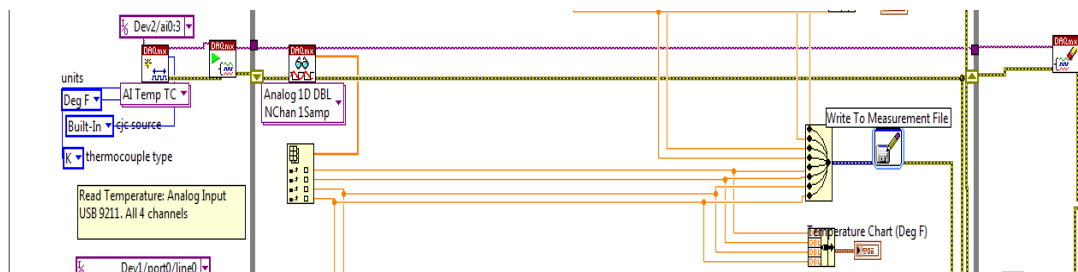

**Fig 3.7--Pressure monitoring task in LabVIEW back panel**

### *Monitor Temperature*

The monitor temperature set starts similar to the pressure monitoring set. There is a “Create task DAQmx” which the analog input selection identified for the temperature measurements (Fig 3.8). The signal is characterized as an analog input from device 2

(USB 9221). The drop down menu has all 4 signals of the USB 9221 selected. The units are in Fahrenheit, there is a built in cold junction compensation source, and the apparatus is using type K thermocouple. Next, there is a “Start Task DAQmx” and “Read DAQmx.” The USB 9221 has signal conditioning built in, so the next icon is necessary to split the array into the individual elements. Each element is then bundled to display on a single graph. The orange thermocouple and pressure transducer signals are combined as the input data in to the “Write to Measurement SubVI.”

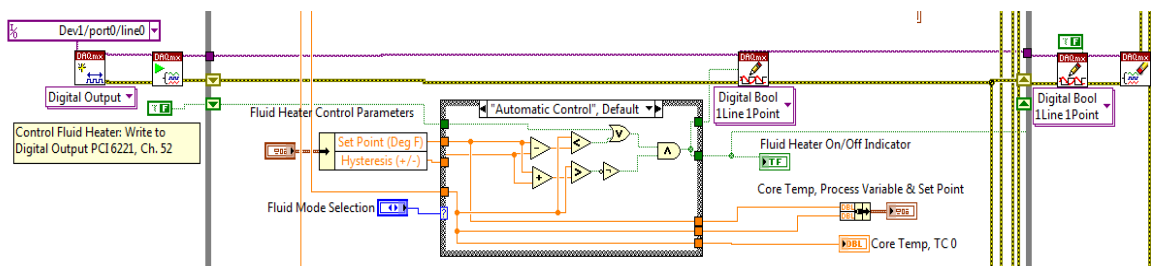

**Fig 3.8—Temperature monitoring task in LabVIEW back panel**

### *Temperature Control*

The temperature control uses the data from the thermocouple as the process variable and the input set point for the on/off negative feedback heater control. The logic works such that the heater turns on until the process variable reaches the set point. The hysteresis value is the range the temperature is allowed to decrease until the heater turns on again. This is beneficial so the controller isn't over worked. For example, a set point of 250 degF and a hysteresis of 2 degF mean the heater will turn on until the thermocouple reads 250 degF, though will not turn on again until the temperature drops below 248

degF. The process variable, hysteresis and set point data line proceeds through a case structure. The case structure has three different cases, “Automatic Control, Override Off, and Override On.” The “Automatic Control” is the default case in which the heater turns on or off depending upon the feedback logic (Fig 3.9). If the white drop down box is clicked, the other options can be viewed. “Override Off” carries all three values through the case structure creating an off signal to the digital output. “Override On” does the opposite by turning the heater on. The blue icon is the mode selection, so the three options in the case structure can be controlled on the front panel. The process variable (thermocouple measurement) and set point is bundled together to be displayed on the same graph on the front panel. The green icon is the indicator light on the front panel. Depending on the set point and process variable, the program sends digital data either a 0 or 1 which corresponds to 0 volts (off) or 5 volts (on) that gets amplified by the solid state relay.



**Fig 3.9—Temperature control task in LabVIEW back panel**

## CHAPTER IV

### PROCEDURE: MATRIX ACIDIZING APPARATUS OPERATION

First, it is necessary to gather information about the core by performing a Computer Tomography scan (optional) and saturating the core. The core is then placed in the core holder, pressurized and fluid is injected and passes through at a constant flow rate while pressure, temperature, rates and volumes are monitored and recorded. Before acidizing, the overburden pressure, back pressure, flow rate, and temperature are set and maintained constant, while the differential pressure across the core is recorded in LabVIEW which can then be analyzed post experiment. The procedure below describes permeability determination through pressure differential build up using water. Then, acid is injected until a continuous wormhole is created through the core. The procedure can be modified depending on the application. It is recommended to have a single notebook to thoroughly comment during experiments.

The general steps for core flooding are listed below and described further in subsequent sections:

1. Weigh the core for dry mass, saturate the core with water, measure core saturated mass and calculate porosity.
2. Place the core in core holder, mount, and connect the inlet and outlet lines.
3. Prepare the acid mixture.
4. Refill the syringe pump, brine and acid accumulators.

5. Apply an overburden pressure of 300 psi using the hydraulic hand pump.
6. Apply back pressure of 3000 psi using the nitrogen tanks.
7. Start LabVIEW.
8. Turn on the syringe pump and inject water at room temperature to measure permeability and increase overburden as needed to remain 300 psi over injection pressure.
9. Turn on the core heater and fluid heater.
10. Continue to inject water until temperature has been reached and the differential pressure has stabilized (Change the syringe pump injection rate if necessary).
11. Inject acid at the desired flow rate and wait for breakthrough (when differential pressure drops to 0 psi).
12. Switch the pump off and close the inlet valve, release back pressure and confining pressure.
13. Flush the flow lines with water to clean out the system.

#### 4.1 Safety Precautions

The core flooding experiments are conducted with hazardous material under high pressure and high temperature and therefore safety must be emphasized. The apparatus is positioned below an overhead elephant hood ventilation unit and a plastic sheet can be dropped down around the frame to protect the user. Each user should be dressed in appropriate lab safety gear including a lab safety coat, goggles, closed toed shoes, and gloves whenever conducting experiments. Also, identify the location of the eye washing

station and fire extinguisher before running experiments. There should be no eating or drinking in the laboratory and it is important to keep spaces clean and organized. There are required lab safety courses online which can be accessed through the SSO login and found under TrainTraq System. Before operating the apparatus the user should be trained by a veteran user. Also, run experiments with no pressure and water to become familiar with valve operation and fluid flow.

#### *4.1.1 Chemical Hazards*

Hydrochloric acid is a highly corrosive substance in which all exposure should be avoided. In all cases of exposure, immediately flush with water, and afterward seek medical attention. In case of eye contact, remove contact lenses if necessary and flush the eyes with water occasionally lifting the lower and upper lids. Similarly, in case of skin contact, remove the clothing and flush with water. If inhaled in extreme amounts, move the person to fresh air and allow resting while in the half-upright position. If ingested, do not induce vomiting, though seek medical attention immediately.

Hydrochloric acid should be stored separately from combustible and reducing substances, strong oxidants, strong bases, metals and kept cool and dry in a well-ventilated room. It should be prepared and stored under the laboratory fume hood in clearly marked containers. Also, pour all hydrochloric acid solutions, regardless of concentration, in to the large, blue bins which are disposed of by the building laboratory manager. Do not leave acid volume in any apparatus components and flush all flow lines of the apparatus with water at the end of all experiments to reduce corrosion effects.

## 4.2 Pre-Core Flood Procedures

Before the core flood is performed, certain rock properties are determined which aide in data interpretation. To calculate effective porosity, core dimensions are recorded and the core is saturated with water. An optional procedure is to use a Computer Tomography (CT) scanner to help visualize rock heterogeneities.

### *4.2.1 Preparing Core*

API Standard 40 emphasizes the importance of core screening and preparation. Once the cores are received, lay out the cores to be analyzed, check the amount of core with the coring report, check numbering and ordering, and be sure to accurately mark and keep track of core received. There is core storage in the cabinets in the laboratory. It is very important to label and date each core for future students.

### *4.2.2 CT Scan*

A Computed Tomography scanner (CT scan) is a valuable tool to visualize the internal structure of the core and heterogeneities including fractures, vugs, and the created wormhole after core flooding. The core is placed in the center of the machine that emits a series of X-rays along the axis. The result is a set of CT numbers at each cross section that correspond to the density of the material. High CT numbers indicate high density and low CT numbers represent low density. Through computer processing, each cross section can be viewed individually as well as converted in to a 3-D object. Fig. 4.1 is the department CT scanner located on the 8<sup>th</sup> floor.



**Fig. 4.1-- CT scanner**

#### 4.2.3 Measuring Porosity

Porosity is defined as the difference between pore volume and bulk volume. It is determined as a mass ratio by weighing the core before and after core saturation. To determine the effective porosity:

- Place the core on the mass scale and record the dry mass.
- Follow the procedure in the section below to saturate the core.
- Measure the mass of the rock after saturation.
- Calculate porosity % using the equation below in laboratory units: core mass in grams (Mass), core diameter in inches (D), core length in inches (L)

$$\phi = \frac{PV}{BV} = \frac{(Mass_{wet\ rock} - Mass_{dry\ rock})}{(2.54 * D)^2 * \frac{\pi}{4} * L * 2.54} * 100 \quad (4.1)$$

#### 4.2.4 Core Saturation

Cores are placed in a water saturation cell to remove all air that is present in the pore spaces. The presence of air or any gas in the system will cause undesirable two phase



flow and gas compressibility will affect the pressure response. Follow the steps below to saturate the core in lab 821:

- Fill the glass bowl with water and place the cores in it (Fig 4.2). The cores should be completely submerged in water.
- Use vacuum grease to coat the outer ring of the bottom of the glass lid and slide it on to the bowl.
- Turn on the vacuum pump by flipping the red switch and leave on for 24 hours (Fig 4.3).

*Observations:* There should be some bubbles coming out of the top and the pressure displayed on the front of the vacuum pump should be approximately 0.8 psi. If not, the top is not securely positioned. The pump pressure after 24 hours should be ~0.6 and the water level should drop a noticeable amount depending on the size of the core.

- Turn off the vacuum pump.
- Place the core samples in another container with water while transporting.

*Tip:* While one core is being saturated, put the next core in a bowl of water to prepare it.



**Fig. 4.2-- Saturation cell in lab 821**



**Fig. 4.3-- Vacuum pump.**

### 4.3 Apparatus Preparation

The next section describes the procedures that should be completed before core flooding to prepare the apparatus. This involves preparing the acid mixture, assembling and mounting the core holder, connecting the heaters, refilling the syringe pump, and refilling the accumulators.

#### 4.3.1 Prepare Acid Mixture

Acid strengths vary according to the application for matrix acidizing experiments. For the Middle East carbonate cores, typical concentration is 15%. The acid should be prepared under the fume hood using a plastic beaker and graduated cylinder (Fig 4.4) . To prepare the acid mixture, first determine the volume of total solution, then calculate the volume of HCl from the commercially available HCl, and then calculate the remaining volume of water. Below is an example calculation to prepare 500 mL of 15% HCl ( $\rho=1.07@60$  degF) using commercially available 36.8wt% ( $\rho= 1.18$ ) HCl:

- Calculate volume from 31.45 wt% HCl solution:

$$\text{Volume HCl} = \frac{\% \text{ wt}_{\text{final}} * \rho_{\text{final}}}{\% \text{ wt}_{\text{initial}} * \rho_{\text{initial}}} * \text{total volume} = \quad (4.2)$$

$$\frac{0.15 * 1.07}{0.368 * 1.18} * 500 = 185 \text{ mL}$$

- Calculate the volume of water:

$$\text{Volume of water} = \text{total volume (mL)} - \text{volume HCl} \quad (4.3)$$

$$500 \text{ mL} - 185 \text{ mL} = 315 \text{ mL}$$

- The solution to obtain 500 of 15% HCl from a HCl solution with 36.8 wt% is:

$$315 \text{ mL of water} + 185 \text{ mL of 36.8 wt\% HCl} \quad (4.4)$$



**Fig 4.4—Hydrochloric acid preparation**

#### *4.3.2 Core Holder Assembly*

The core holder subassembly, which includes the Viton sleeve, ferrules, O-rings, and end caps, should remain assembled unless one of the components needs to be replaced. The mounting post also remains intact unless changing between the 1” and 1.5” diameter core holders. The main assembly is taken on and off for each experiment.

##### *Core holder sub-assembly*

- Install one O-ring on each ferrule.
- Install one ferrule on the end of the rubber sleeve and lubricate the ferrule with motor oil.
- Slide the rubber sleeve into the core holder, end without the ferrule first. Be sure the end with the ferrule seats completely and tap it into place with a rubber mallet.
- Lubricate the free ferrule with motor oil and slide it in to the sleeve exactly like the other one and tap to ensure it is seated.

### *Core Holder Main Assembly*

The smaller core holder subassemblies should be taken off the frame and lying horizontally on a sturdy lab surface. They can be placed in the blue stands provided by the manufacturer. The large core holder should be rotated and locked horizontally in the frame.

- Slide the core into the core holder body. The Viton sleeve will be surrounding it.
- Locate the stationary platen and insert it into the corresponding end cap (Fig. 4.5). The stationary platen is shorter of the two. It has flanges protruding radially from the metal cylinder which slides into the end cap with flanges on the inner diameter. Slide the smooth side of the platen into core holder body, twist the platen so that the flanges overlap. Tighten the banana screw protruding from the end cap to ensure the alignment.
- Push the core so that it is flush against the stationary platen.
- Locate the floating platen, longer of the 2 metal cylinders, and insert it in to the corresponding end cap (Fig. 4.6). Slide the smooth side in to the core holder body. The end with a small divot should be exposed.

Locate the tightening assembly with the adjusting screw. Align the grooves on the inside of the metal half cylinder with the floating platen end cap. Tighten the large bolt until it fits in to the divot on the top of the floating platen. Continue to turn the screw, which pushes the floating platen into the core holder, until it becomes difficult to tighten. This ensures the core has bottomed out against the stationary platen.

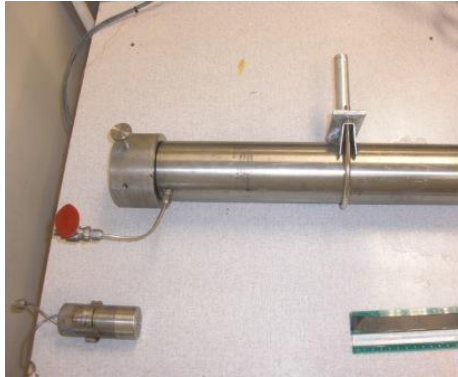

**Fig 4.5-- Stationary platen, banana bolt, and end cap**



**Fig 4.6-- Floating platen, tightening assembly and end cap**

### *Wrap Heating Tape*

- Select the correct heating tape to be used depending on the core holder.
- Wrap the heating tape around the core holder, but do not to overlap (Fig 4.7).
- Place the cement on thermocouple on the metal core holder. The black putty tape can be used to keep the thermocouple it in place and ensure the thermocouple is not on the heating tape.
- Wrap microfiber insulation around and secure with tape.



**Fig 4.7— Core holder with heating tape**

### *Core Holder Mounting*

When performing a core flood on the medium or small core holder, the right side of the apparatus should be used. For the small core holder, only the top pole with a hole in it is used. The top and bottom pole are used for the medium sized core holder to support the load and prevent movement. Fig 4.8 shows the U-beams and poles used to attach to the apparatus. Simply put the U-ring around either the 1.5'' or 1'' core holder, slide the post on, and use the screws to secure (Fig 4.9).

- To mount, insert the top pole into the post on the apparatus frame, lining up the hole in the pole with the hole on the frame post. Also, confirm the bottom pole seats correctly in the bottom post.
- Take the pin attached to the small chain and insert it in the hole (Fig 4.10). It may be necessary to jiggle the pole to get the hole to line up so the pin can be inserted.



**Fig 4.8—Core holder mounting components**



**Fig 4.9—Mounting attached to core holder**

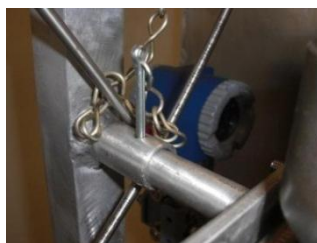

**Fig 4.10—Mounting attached to frame**

### *Connect Core Holder Tubing*

- Connect the fluid injection tube to the bottom of the core holder since this is the connection with the tightest fit. Then, connect the other inlet tube to the tube connecting to the *High Pressure-Core Inlet, Pressure Transducer Valve Series* (CH1 2- way ball valve for 4'' core or CH2 2-way valve for 1.5'' & 1'' cores). It does not matter which tubing from the core holder fits with injection inlet/outlet tube or pressure transducer tube.
- Connect one outlet tube at the top of the core to the *Low Pressure-Core Outlet, Pressure Transducer Valve Series* and the second to the BPR (CH1 for 4'' or CH2 for 1.5'' & 1'').
- Connect the bottom port on the surface of the core holder cylinder to the *Overburden* ball valve.
- The top port should be connected to a relief or needle valve with the tubing from the other end of the valve releasing into a beaker. The beaker catches the motor oil when overburden is released.

### *4.3.3 Connect Heaters*

There are two heaters to connect, the fluid heater and core heater. Insulation should already be wrapped around the core holder and tubing connecting the fluid heater to the core holder.

- The fluid heater and heating tape have a gray plug on them. When the core holder is situated, plug them in to the black cords connecting to the metal box with the solid state relays. The same end piece connected to the heating tape can

be unscrewed and connected to heating tapes on the other core holders. Just confirm there is metal to metal contact.

#### *4.3.4 Syringe Pump Operation*

The continuous flow dual pump operates such that the pumps should refill automatically (Fig 4.11). However, it is good practice to make sure both pumps are filled at the beginning of the experiment. The volume and pressure in each pump is displayed on the front panel. Fill the syringe pump flask with hydraulic oil. The plastic tube from this flask connects to the syringe pump electric valve system. The other stainless steel tubing connects to the *Syringe Pump Valve Series*. Check this flask periodically throughout the experiment to make sure that it is full. If there is no oil in the flask, the pumps will fill with air.



**Fig 4.11--Syringe pump and controller**



The following steps assume the pumps are off:

- Switch the red button on the surface of each pump to “on” to turn on the power
- Press “refill” blue button
- Press “A” button to refill pump A (will stop automatically when filled)
- Press “refill” blue button
- Press “B” button to refill
- Refill both tanks to full volume = 266mL
- Press “menu” button
- Press “A” (more)
- Press “4” for multi pump
- Press “1” for continuous constant flow
- Options along the bottom:
  - A “normal”
  - C “normal pressure”
  - C “deliver”
  - D
- Press “D” 2 times to get to front menu screen
- To enter the desired flow rate in the pump controller:
- Press “A” to enter flow rate
- Enter the flow rate in numbers
- Press “enter”
- Press “run”
- At first, both pumps will run at the same time. Then, pump A will start refilling and only pump B runs

#### 4.3.5 Refill Accumulators

To refill the accumulators, the fluid is poured in to the clear PVC cylinder and the lab air source pushes the fluid into the bottom of the piston accumulator through valve manipulation.

- Remove the screw on the top of the PVC refill cylinder.
- Confirm both *accumulator outlet* 3-way ball valves and the *refill discharge* 2-way ball valves are off. The yellow handle should be protruding straight out on

the 3-way ball valves and the black 2-way ball valve should be perpendicular to the flow line.

- Place the funnel in the hole at the top of the refill tank and pour the fluid in the clear cylinder.
- Attach the air source to the 1/8" Swagelok connection protruding from the top end piece.
- Open the *accumulator inlet* 2-way ball valve at the top of the accumulator to be refilled and the *air release* in the Injection Pump Valve Series. The 2-way ball valves for the accumulator not being refilled and the Injection Pump Valve Series should be closed.
- Open the 3-way ball valve in the refill direction below the accumulator to be refilled (yellow handle on the right for the HCl accumulator and on the left for the brine accumulator)
- Turn on the lab air source by turning the lever perpendicular

*Observations:* The fluid level in the PVC cylinder should be dropping when the air source is on. Hydraulic oil should be coming out of the *air release* valve in the Injection Pump Valve Series in a 1 to 1 ratio. This is another way to confirm the volume of fluid injected into the accumulator. If not, there is air in top part of the piston accumulator.

- When the fluid level is nearing the bottom, close the 3-way ball valve to ensure no air gets in the bottom part of the piston accumulator.
- Open the *refill discharge* 2-way ball valve below the refill container.

- Turn off the air source.
- After refilling the acid accumulator, flush the refill container with water since extensive exposure to HCl deteriorates equipment.

*Observations:* The air does not turn off immediately when the air source valve is closed so keep the *refill tank discharge* valve open until the air has stopped.

*Tip:* Refill accumulators with at least an additional 250 mL of fluid above the expected amount used in the experiment to account for unforeseen issues.

*Tip:* To bleed air from the bottom of the accumulator, open the *refill tank discharge* valve, position the *accumulator outlet* 3-way ball valve to the refill position and turn on the injection pump. This way it is possible to confirm there is no excess air in the flow lines from the refill tank to the accumulator. The valve positions to refill the acid and brine accumulators are shown in Table 4.1 and 4.2 respectively.

TABLE 4.1—VALVE CONFIGURATION FOR ACID REFILL		
Valve Placement	Valve Type	Position
<i>Injection Pump Valve Series</i>		
Injection pump outlet	2-way	Off
HCl accumulator inlet (top)	2-way	On
Brine accumulator inlet (top)	2-way	Off
Air release outlet	2-way	On
<i>Accumulator Valve Series</i>		
Refill tank discharge	2-way	Off
HCl accumulator outlet (bottom)	3-way	Right
Brine accumulator outlet (bottom)	3-way	Off

TABLE 4.2—VALVE CONFIGURATION FOR BRINE REFILL		
Valve Placement	Valve Type	Position
<i>Injection Pump Valve Series</i>		
Injection pump outlet	2-way	Off
HCl accumulator inlet (top)	2-way	Off
Brine accumulator inlet (top)	2-way	On
Air release outlet	2-way	On
<i>Accumulator Valve Series</i>		
Refill tank discharge	2-way	Off
HCl accumulator outlet (bottom)	3-way	Left
Brine accumulator outlet (bottom)	3-way	Off

## 4.4 Core Flooding Procedure

### 4.4.1 Apply Overburden

To review, the core is placed inside the Viton or rubber, black sleeve. The rubber sleeve is inside the metal core holder. The confining pressure is applied by pushing oil into the volume between the Viton sleeve and the metal core holder. The oil “squeezes” the core sample increasing the pressure surrounding the core to simulate overburden pressure of the reservoir at depth. The overburden pressure, read from the pressure gauge attached to the hydraulic hand pump, must be at least 300 psi higher than the inlet pressure to ensure that fluid is injected into the core. If not, the fluid will bypass the core and travel between the core sample and Viton sleeve.

- The 1/8” tubing from the *overburden* 3-way ball valve should be connected to the bottom port on the outer cylinder of the core holder. The bottom of this 3-way ball valve is connected to the ENERPAC hydraulic hand pump.
- To apply overburden pressure to Core 1, turn the yellow lever to the right. To apply overburden pressure to Core 2, turn the yellow handle to the left.
- Ensure the needle valve connected to the top port on the core holder is closed.
- Ensure the ENERPAC pump is filled with enough 15W-40 motor oil. If not, open the black screw cap and pour in oil and close.
- Lift and press down the lever on the hydraulic hand pump until pressure increases to about 700 psi. It will take a many pumps to start pressure build up since the volume between the sleeve and metal core holder must be filled first.

- The overburden pressure should be monitored throughout the entire experiment remaining 300 psi above inlet pressure. It will be necessary to apply more pressure as build up is occurring during brine injection.

*Observations:* The pressure should increase steadily and hold. If the pressure drops, check if there is a leak in any of the lines and fittings from the hydraulic pump to the core holder. If all the leaks are fixed, it is possible that the ferrule in the core holder subassembly did not seal properly.

#### *4.4.2 Select Pressure Transducer*

Select the pressure transducer based on the delta P calculated by rearranging Darcy's equation and using an anticipated permeability. If unsure of permeability, start by using PT1, 0-2000psi range. If the pressure drop is below 200psi, change to PT2, 0-200psi pressure range for increased accuracy. See the Table 4.3, 4.4, 4.5, and 4.6 for valve configuration.

TABLE 4.3-- VALVE CONFIGURATION FOR CORE 1, PT 1

<u>Valve Placement</u>	<u>Valve Type</u>	<u>Position</u>
<i>Low Pressure- Core Outlet, Pressure Transducer Valve Series</i>		
PT1, 0-2000psi	2-way	On
PT2, 0-200psi	2-way	Off
Core 1 outlet (4" X 20")	2-way	On
Core 2 outlet (1.5" X 20" or 1" X 6")	2-way	Off
<i>High Pressure-Core Inlet, Pressure Transducer Valve Series</i>		
PT1, 0-2000psi	2-way	On
PT2, 0-200psi	2-way	Off
Core 1 inlet (4" X 20")	2-way	On
Core 2 inlet (1.5" X 20" or 1" X 6")	2-way	Off

TABLE 4.4-- VALVE CONFIGURATION FOR CORE 1, PT 2

<u>Valve Placement</u>	<u>Valve Type</u>	<u>Position</u>
<i>Low Pressure- Core Outlet, Pressure Transducer Valve Series</i>		
PT1, 0-2000psi	2-way	Off
PT2, 0-200psi	2-way	On
Core 1 outlet (4" X 20")	2-way	On
Core 2 outlet (1.5" X 20" or 1" X 6")	2-way	Off
<i>High Pressure-Core Inlet, Pressure Transducer Valve Series</i>		
PT1, 0-2000psi	2-way	Off
PT2, 0-200psi	2-way	On
Core 1 inlet (4" X 20")	2-way	On
Core 2 inlet (1.5" X 20" or 1" X 6")	2-way	Off

TABLE 4.5-- VALVE CONFIGURATION FOR CORE 2, PT 1

<u>Valve Placement</u>	<u>Valve Type</u>	<u>Position</u>
<i>Low Pressure- Core Outlet, Pressure Transducer Valve Series</i>		
PT1, 0-2000psi	2-way	On
PT2, 0-200psi	2-way	Off
Core 1 outlet (4" X 20")	2-way	Off
Core 2 outlet (1.5" X 20" or 1" X 6")	2-way	On
<i>High Pressure-Core Inlet, Pressure Transducer Valve Series</i>		
PT1, 0-2000psi	2-way	On
PT2, 0-200psi	2-way	Off
Core 1 inlet (4" X 20")	2-way	Off
Core 2 inlet (1.5" X 20" or 1" X 6")	2-way	On

TABLE 4.6-- VALVE CONFIGURATION FOR CORE 2, PT 2

<u>Valve Placement</u>	<u>Valve Type</u>	<u>Position</u>
<i>Low Pressure- Core Outlet, Pressure Transducer Valve Series</i>		
PT1, 0-2000psi	2-way	Off
PT2, 0-200psi	2-way	On
Core 1 outlet (4" X 20")	2-way	Off
Core 2 outlet (1.5" X 20" or 1" X 6")	2-way	On
<i>High Pressure-Core Inlet, Pressure Transducer Valve Series</i>		
PT1, 0-2000psi	2-way	Off
PT2, 0-200psi	2-way	On
Core 1 inlet (4" X 20")	2-way	Off
Core 2 inlet (1.5" X 20" or 1" X 6")	2-way	On

#### 4.4.3 Check System for Leaks, Air and Proper Operation

It is helpful to fill as much tubing with fluid to minimize dead volume and bleed out air that may be in the tubing before core injection. Common areas air gets trapped is in the tubing from the injection pump to the inlet of the accumulator pushing air inside the top of the accumulator, the tubing from the refill tank to the accumulator pushing air in the bottom of the accumulator, the tubing from the accumulator outlet to the core inlet, and the tubing from the outlet of the core to back pressure regulator.

To ensure no air is being pushed in to the top of the accumulator:

- Open the *air release outlet* valve in the Injection Pump Valve Series.
- Inject at a flow rate of 20 cc/min to confirm a steady stream of oil is coming out of the tubing leading to the oil release and all tubing in the Injection Pump Valve Series are filled with hydraulic oil. Confirm flow rate is equal to the syringe pump flow rate.
- Open the *HCl accumulator inlet* and *Brine accumulator inlet* in the Injection Pump Valve Series. The valves at the bottom of the accumulators remain closed.
- Close the *air release outlet* valve and ensure pressure is building in the pump meaning the piston in the accumulators are as far down as possible.

To ensure no air is in the tubing from the accumulator to the core:

- Open the 3-way ball valve to air release, yellow handle up, beneath the core to be injected in the Core Injection Series.
- Inject brine at any flow rate and confirm flow rate coming out of the valve is equal to the injection pump flow rate
- Refer to Table 4.7 and 4.8 for valve configuration

To fill the fluid line from the core outlet to the back pressure regulator:

- Turn off the *Core injection* 3-way ball valve in the BPR Series.
- Turn on the *core inlet* 2-way ball valve in the BPR Series.
- Inject brine until the water coming out of the BPR is equal to the injection pump flow rate.
- Once steady flow rate is achieved, turn off the *core inlet* 2-way ball valve in the BPR Series and the syringe pump.

- Refer to Table 4.9 and 4.10 for valve configuration

TABLE 4.7: VALVE CONFIGURATION FOR INJECTION PUMP TO ACCUMULATOR AIR RELEASE		
<u>Valve Placement</u>	<u>Valve Type</u>	<u>Position</u>
<i>Injection Pump Valve Series</i>		
Injection pump outlet	2-way	On
HCl accumulator inlet (top)	2-way	Off
Brine accumulator inlet (top)	2-way	Off
Air release outlet	2-way	On
<i>Accumulator Valve</i>		
Refill tank	2-way	Off
HCl accumulator outlet (bottom)	3-way	Off
Brine accumulator outlet (bottom)	3-way	Off

TABLE 4.8: VALVE CONFIGURATION FOR ACCUMULATOR TO CORE 1 & CORE 2* AIR RELEASE		
<u>Valve Placement</u>	<u>Valve Type</u>	<u>Position</u>
<i>Injection Pump Valve Series</i>		
Injection pump outlet	2-way	On
HCl accumulator inlet (top)	2-way	Off
Brine accumulator inlet (top)	2-way	Off
Air release outlet	2-way	On
<i>Core Inlet Valve</i>		
Core 1 inlet (4" X 20")	3-way	Up <i>Off*</i>
Core 2 inlet (1.5" X 20" or 1" X 6")	3-way	Off <i>Up*</i>

TABLE 4.9: VALVE CONFIGURATION FOR CORE 1, BPR FILL		
<u>Valve Placement</u>	<u>Valve Type</u>	<u>Position</u>
<i>Core Inlet Valve Series</i>		
Core 1 inlet (4" X 20")	3-way	Off
Core 2 inlet (1.5" X 20" or 1" X 6")	3-way	Off
<i>Core Outlet/Back Pressure Valve</i>		
Core Inlet/Outlet	2-way	On
Core 1 outlet (4" X 20")	2-way	On
Core 2 outlet (1.5" X 20" or 1" X 6")	2-way	Off

TABLE 4.10: VALVE CONFIGURATION FOR CORE 2, BPR FILL		
<u>Valve Placement</u>	<u>Valve Type</u>	<u>Position</u>
<i>Core Inlet Valve</i>		
Core 1 inlet (4" X 20")	3-way	Off
Core 2 inlet (1.5" X 20" or 1" X 6")	3-way	Off
<i>Core Outlet/Back Pressure Valve</i>		
Core Inlet/Outlet	2-way	On
Core 1 outlet (4" X 20")	2-way	Off
Core 2 outlet (1.5" X 20" or 1" X 6")	2-way	On

#### 4.4.4 Apply Back Pressure

The back pressure is used to keep CO<sub>2</sub> byproduct in solution. At elevated temperatures, it must be at least 3000psi. The external pressure is applied to the top of the dome using nitrogen.



- If the nitrogen tank is completely off, the gold colored valve on the Nitrogen tank is tight to the right (Fig 4.12).
- Slowly open the circle valve on top of the nitrogen tank by turning to the left all the way. The gauge on the right displays the pressure inside the tank.
- Slowly open the gold colored valve until the pressure gauge on the left says 3000psi. The pressure gauge above the back pressure regulator should be a steady 3000psi. If not there is a leak in the tubing.



**Fig 4.12—Nitrogen tanks**

#### *4.4.5 Start LabVIEW*

- Open the LabVIEW file “Matrix Acidizing 1001 “ on the computer. This brings up the front panel where there are graphs and user input parameters.
- Enter in the core dimensions in the “Experiment Parameters” on the front panel.
- Pressure Channel Parameters should remain default as show in Fig 4.13

- Fluid Heater and Core Heater Parameters should be “Automatic Control.” Do not turn on heater at this point. It is possible to manually override the heaters by selecting the drop down arrows to the left of “Fluid Mode Selector” and select “Override Off.” This is turn the heaters off, but continues to collect pressure data.
- Press the black arrow at the top left corner of the LabVIEW window to start the data acquisition.
- A box will appear to select the location and file name to save the file. It is recommended to include the type of rock, experiment number, and date when naming data sets, i.e. “Qatar outcrop1\_12.1.11.” If the file name is not changed, the data will over write the previous data.

*Tip:* Temperature of all 4 thermocouples is in the top left graph in the red box. Room temperature should remain about 60-75 degF. If the thermocouple reading jumps to 4000-5000 it means the thermocouple is broken and not reading temperature correctly. Double check the wire connections which may need to be re-secured. The yellow wire is the negative and red wire is the positive terminal.

The top left graph is the temperature graph. Below the temperature graph is the instantaneous permeability vs. time calculated using Darcy’s Law from the input dimensions of the core and the changing delta P from the PT1, 0-2000psi (white line) and PT2 0-200psi (red line). Though both lines for the instantaneous permeability calculated from either pressure transducer are on the same graph, only the pressure

transducer being used will show a changing permeability value. The permeability of the core can be read once the pressure drop has stabilized.

The graph in the green box is the pressure drop versus time across the core. The top graph is PT1, 0-2000psi range and the bottom graph is the 0-200psi range. Again, only one graph will be displaying correct pressure drop data.

The blue box on the right of the front panel graphs the temperature reading (red line) vs. time for the fluid heater on top and the core heater on bottom. The white line indicates the set temperature which is manually put in the Heater Control Parameters. When the temperature reading is below the set temperature, the heater will turn on as indicated by the green button.

In each of the graphs, the actual numeric value can be read at the top of the graph next to the line color label.

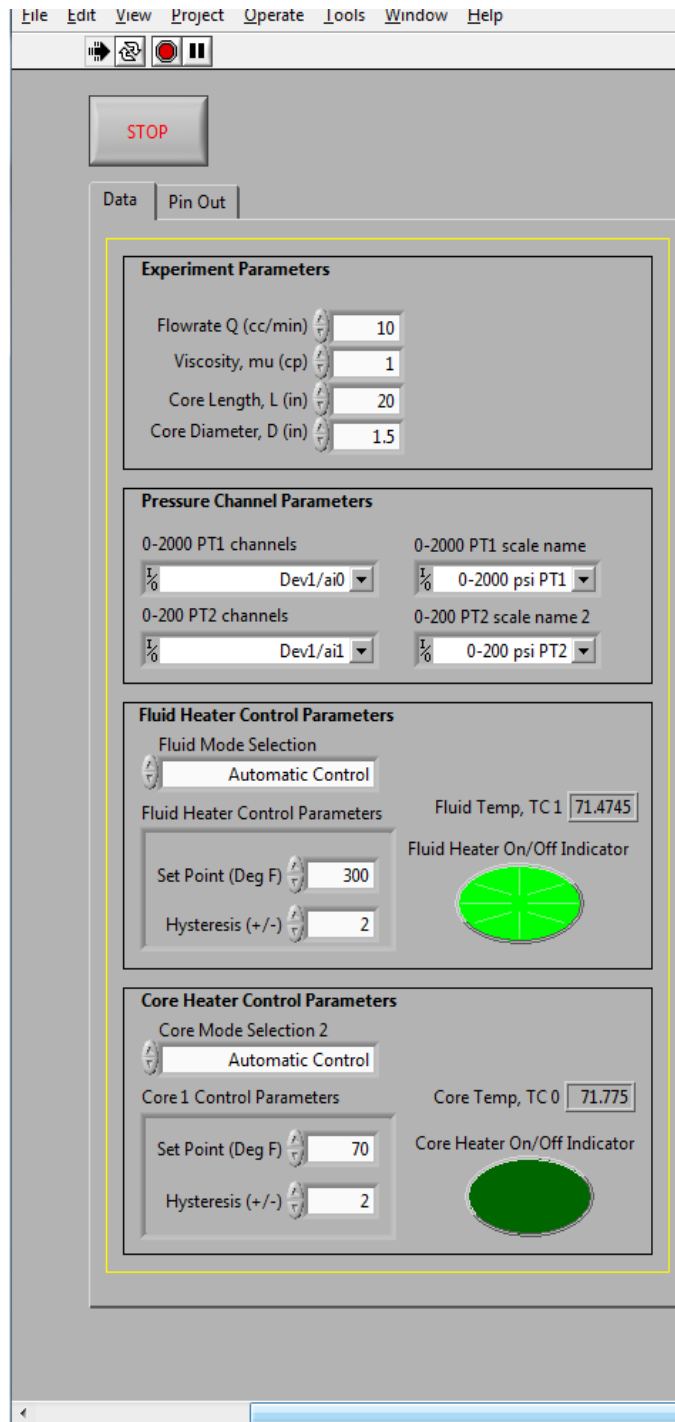

Fig 4.13—LabVIEW front panel parameters

#### 4.4.6 Inject Brine to Achieve Steady State

After the data acquisition has started, it is time to inject brine and wait to reach steady state. The pressure at which the delta P becomes constant is the value to put in to Darcy's linear flow equation to calculate the directional permeability. It will also be displayed on the Permeability Chart on the LabVIEW front panel. Calculate the initial flow rate using Darcy's law with an estimated permeability such that the delta P is 100-2000psi. The upper limit is necessary for equipment to remain within ratings when a back pressure of 3000psi is applied (5000psi-3000psi). The delta P should also be large enough so that small fluctuations will not dramatically affect the calculation. Refer to Table 4.11 and 4.12 for valve configuration. The following should be confirmed:

- Overburden pressure is at least 700psi. Continually apply overburden as necessary throughout the buildup to remain 300psi above injection pressure (Section 4.4.1)
- Back pressure is 3000psi (Section 4.4.2)
- Pressure transducer is selected (Section 4.4.3)
- Outlet tubing is filled with fluid and BPR outlet configuration is correct (Section 4.4.4)
- Brine Accumulator Outlet 3-way ball valve is in *core injection* direction (yellow handle right)
- The *core inlet* 3-way ball valve of the core is open to air release -yellow handle is on top near the core inlet, so fluid is going in to the beaker beneath the core.
- Enter in the desired flow rate in the injection pump and press "run."

- Use a stop watch and beaker to confirm the correct amount of volume is coming out beneath the *core injection* 3-way ball valve as entered in the syringe pump control panel.
- Switch the *core injection* 3-way ball valve to the core injection position, yellow handle is below valve.

*Observations:* Core inlet and outlet pressure are displayed on the pressure gauges connected to the pressure transducer lines. Core inlet pressure will increase dramatically at first and then level off.

- Calculate permeability when steady state (pressure drop is constant) is reached as shown in LabVIEW when delta P stabilizes. Obtain about 30minutes of data with delta P fluctuations within ~3 psi.
- Turn on the core and fluid heater by entering in “300” in the Set Point window of the LabVIEW front panel and wait to reach steady state once more. Release the overburden oil as needed while temperature increases overburden pressure.

TABLE 4.11-- VALVE CONFIGURATION FOR CORE 1, BRINE INJECTION		
<u>Valve Placement</u>	<u>Valve Type</u>	<u>Position</u>
<i>Injection Pump Valve</i>		
Injection pump outlet	2-way	On
HCl accumulator inlet (top)	2-way	On
Brine accumulator inlet	2-way	On
Air release outlet	2-way	Off
<i>Accumulator Valve</i>		
Refill tank	2-way	Off
HCl accumulator outlet	3-way	Off
Brine accumulator outlet	3-way	Left
<i>Core Inlet Valve Series</i>		
Core 1 inlet (4" X 20")	3-way	Down/Left
Core 2 inlet (1.5" X 20" or	3-way	Off
Inlet gas flow back	2-way	On
<i>Back Pressure/ Core Outlet Valve</i>		
Core Inlet	2-way	Off
Core 1 outlet (4" X 20")	2-way	On
Core 2 outlet (1.5" X 20" or 1" X 6")	2-way	Off

TABLE 4.12-- VALVE CONFIGURATION FOR CORE 2, BRINE INJECTION		
<u>Valve Placement</u>	<u>Valve Type</u>	<u>Position</u>
<i>Injection Pump Valve</i>		
Injection pump outlet	2-way	On
HCl accumulator inlet (top)	2-way	On
Brine accumulator inlet	2-way	On
Air release outlet	2-way	Off
<i>Accumulator Valve</i>		
Refill tank	2-way	Off
HCl accumulator outlet	3-way	Off
Brine accumulator outlet	3-way	Right
<i>Core Inlet Valve Series</i>		
Core 1 inlet (4" X 20")	3-way	Off
Core 2 inlet (1.5" X 20" or	3-way	Down/Right
Inlet gas flow back	2-way	On
<i>Back Pressure/ Core Outlet Valve</i>		
Core Inlet	2-way	Off
Core 1 outlet (4" X 20")	2-way	Off
Core 2 outlet (1.5" X 20" or 1" X 6")	2-way	On

#### 4.4.7 Inject Acid

- Record the volume in the syringe pump.
- Switch valves to acid injection as quickly as possible in order:
  - Open the *HCl accumulator outlet* to core injection (yellow handle right)
  - Turn off the *Brine accumulator outlet* (yellow handle perpendicular).
  - Refer to Table 4.13 and 4.13 for valve configuration
- Breakthrough occurs when the pressure drop across the core becomes negligible, ~ 15psi. It will take some time to decrease depending on the injection rate.
- Record the volume in the syringe pump when breakthrough occurs.

TABLE 4.13-- VALVE CONFIGURATION FOR CORE 1, ACID INJECTION		
<u>Valve Placement</u>	<u>Valve Type</u>	<u>Position</u>
<i>Injection Pump Valve Series</i>		
Injection pump outlet	2-way	On
HCl accumulator inlet (top)	2-way	On
Brine accumulator inlet (top)	2-way	Off
Air release outlet	2-way	Off
<i>Accumulator Valve Series</i>		
Refill tank	2-way	Off
HCl accumulator outlet (bottom)	3-way	Right
Brine accumulator outlet (bottom)	3-way	Off
<i>Core Inlet Valve Series</i>		
Core 1 inlet (4" X 20")	3-way	Down/Left
Core 2 inlet (1.5" X 20" or 1" X 6")	3-way	Off
Inlet gas flow back	2-way	On
<i>Back Pressure/ Core Outlet Valve</i>		
Core Inlet	2-way	Off
Core 1 outlet (4" X 20")	2-way	On
Core 2 outlet (1.5" X 20" or 1" X 6")	2-way	Off

TABLE 4.14-- VALVE CONFIGURATION FOR CORE 2, ACID INJECTION		
<u>Valve Placement</u>	<u>Valve Type</u>	<u>Position</u>
<i>Injection Pump Valve Series</i>		
Injection pump outlet	2-way	On
HCl accumulator inlet (top)	2-way	On
Brine accumulator inlet (top)	2-way	Off
Air release outlet	2-way	Off
<i>Accumulator Valve Series</i>		
Refill tank	2-way	Off
HCl accumulator outlet (bottom)	3-way	Right
Brine accumulator outlet (bottom)	3-way	Off
<i>Core Inlet Valve Series</i>		
Core 1 inlet (4" X 20")	3-way	Off
Core 2 inlet (1.5" X 20" or 1" X 6")	3-way	Down/Right
Inlet gas flow back	2-way	On
<i>Back Pressure/ Core Outlet Valve</i>		
Core Inlet	2-way	Off
Core 1 outlet (4" X 20")	2-way	Off
Core 2 outlet (1.5" X 20" or 1" X 6")	2-way	On



#### 4.5 Post Acidizing Procedure

Post acidizing procedure requires releasing back pressure, flushing the system with brine, releasing overburden pressure, removing acid and brine from the accumulator, disassembling the core holder, and clean up. Table 4.15 and 4.16 show the valve configuration for this step.

- Turn off the syringe pump.
- Turn off the *acid accumulator outlet* 3-way ball valve (yellow handle pointing out)
- Press the red “stop” button on the LabVIEW front panel. This will also turn off the heaters.
- Unplug the heaters. It will take a while for the heaters to cool.
- Turn off the nitrogen tank by turning the gold handled valve to the right.
- Open the 2-way ball valve connected to the union tee to release the pressure in the tubing from the nitrogen tank to the BPR.

*Observation:* BPR pressure gauge decreases to 0 psi causing residual CO<sub>2</sub> to become gaseous. Two-phase fluid will quickly flow through the BPR outlet into the discharge container. Once the CO<sub>2</sub> has been expelled, a single phase brine-acid mixture will flow.

- Flush the system with ~ 500mL of brine to reduce corrosion following the brine injection valve configuration.
- Confirm that this has successfully flushed the system by testing the pH of the BPR discharge container. If it is not neutral, continue to flush with brine.

- Turn the *core injection* 3-way ball valve to discharge into the beaker (yellow valve on top) to release any remaining pressure.
- Release overburden oil by opening the needle valve on the side of the core holder.
- Remove the core holder inlet and outlet lines in any order.
- Remove the overburden pressure line and catch the residual oil in a beaker. Mount core holder horizontally and allow oil to drain a few minutes.
- Expel remaining HCl from the acid accumulator by opening the *HCl outlet* valve to refill, opening the *refill tank discharge* 2-way ball valve, and injecting until the injection pump pressure increases sharply indicating no more fluid is in the HCl accumulator. Fluid will discharge in to the plastic beaker beneath the refill tank.
- Expel remaining brine from brine accumulator. Be sure to do this after expelling the acid.
- Disassemble the core holder main assembly.
- Remove core sample using wood rod to push out.
- Use shop towels to clean up any oil or acid spills, pour fluid mixtures in blue bins, rinse out beakers, return all tools to proper position, and confirm all pumps and heaters are off.

TABLE 4.15-- VALVE CONFIGURATION FOR ACID DISCHARGE		
<u>Valve Placement</u>	<u>Valve Type Position</u>	
<i>Injection Pump Valve System</i>		
Injection pump outlet	2-way	On
HCl accumulator inlet (top)	2-way	On
Brine accumulator inlet	2-way	Off
Air release outlet	2-way	Off
<i>Accumulator Valve</i>		
Refill tank discharge	2-way	On
HCl accumulator outlet (bottom)	3-way	Right
Brine accumulator outlet (bottom)	3-way	Off

TABLE 4.16-- VALVE CONFIGURATION FOR BRINE DISCHARGE		
<u>Valve Placement</u>	<u>Valve Type Position</u>	
<i>Injection Pump Valve System</i>		
Injection pump outlet	2-way	On
HCl accumulator inlet (top)	2-way	Off
Brine accumulator inlet (top)	2-way	On
Air release outlet	2-way	Off
<i>Accumulator Valve</i>		
Refill tank discharge	2-way	On
HCl accumulator outlet (bottom)	3-way	Off
Brine accumulator outlet (bottom)	3-way	Left

## 4.6 Common Errors

### 4.6.1 Air in the Accumulator

The air bleed valve before the core holder is a critical bleed valve. It is important to check the flow rate coming out of the bleed valve is the same as the flow rate programmed into the syringe pump. If the flow rate is faster, it is likely there is air in the bottom of the accumulator. In this case, it is necessary to empty the accumulator completely by opening the *refill discharge* 2-way valve. Inject in the top of the accumulator and continue to inject even when fluid stops coming out of the *refill discharge* valve. Stop injecting only when the syringe pump pressure begins to build. The additional fluid volume going into the accumulator is pushing out air which can be confirmed by putting a soap bubble at the tubing outlet.

#### *4.6.2 Core Holder Leaks and Possible Causes*

If oil is leaking out of the core holder, then the overburden oil is going around the core and there is not a tight seal between the sleeve and the core. There is usually a leak in the seal and it needs to be replaced. If water is coming out of the end pieces of the core holder, then the end caps are not secured properly.

## CHAPTER V

### DATA ANALYSIS AND RESULTS

Matrix acidizing core flooding experiments provide vital input parameters for reservoir simulation and field production analysis. The rock properties measured in a typical core flooding experiment include porosity, permeability, and pore volume to breakthrough. The information collected throughout the experiment is listed below with actual data from an Indiana limestone core flood. It is also important to note that precision or repeatability of the pressure drop measurement is limited. In other words, repeating the *Inject Brine to Achieve Steady State* procedure for the same core to verify permeability will yield marginally different pressure drop measurement.

#### 5.1 Recorded Core Data

Basic dimensions of the core should be measured and recorded. Also, to calculate porosity, measure the dry and wet mass of the core using a mass balance. During core flooding, have a stop watch ready to record the time of injection. This number can be confirmed using the flow rate and change in pump volume.

Pre- core flood measurements:

- Core Lithology = Indiana limestone
- Core length (in) = 10
- Core diameter (in) = 1.5
- Dry mass (g) = 625.1
- Wet mass (g) = 668.9

- Length of tubing from accumulator to core (cm) = 193

Data collected during core flood:

- Injection rate (cc/min) = 3.5
- Volume in syringe pump immediately before acidizing (mL) = 217.8
- Volume in syringe pump immediately after acidizing (mL) = 195.9
- Time for acid injection: valve change to  $\Delta P = \sim 15$ psi (sec ) = 360

## 5.2 Generating Graph

Pressing the “run” arrow on the front panel of the LabVIEW prompts a window to save the file in a location designated. Double clicking the LabVIEW data file of the experiment just performed “*name.lv*” will open in excel. Depending on the office version, it may be necessary to open in notepad and copy and paste into an excel file.

Fig. 5.1 shows the information automatically created in an excel file. The columns from right to left are: time (seconds), PT1  $\Delta P$  (psi), PT2  $\Delta P$  (psi), permeability calculated from PT1  $\Delta P$  (mD), permeability calculated from PT2  $\Delta P$  (mD), thermocouple measuring the core holder ( $^{\circ}$ F), thermocouple measuring fluid ( $^{\circ}$ F), thermocouple 3 & 4 ( $^{\circ}$ F) available to measure temperature at other locations on the apparatus. The header above the columns indicates the user, date and time.

Create a scatter plot graph in excel with pressure drop on the y-axis and time on the x-axis (Fig 5.2). The pressure drop at which the curve flattens, is the pressure drop used to calculate permeability. The point at which the pressure drop goes to zero indicates a conductive wormhole through the core.

Record the following data from the graph:

- Steady state pressure drop (psi) = 392

22	Time (s)	PT1	PT2	k1	k2	TC1	TC2	TC3	TC4	Comment
5306	2750.21	428.80965	0.428847	25287.4198	25.289647	72.08888	70.085233	71.646872	83.118105	
5307	2750.744	428.32287	0.376415	28809.7886	25.318387	71.938934	70.056729	71.589828	83.005875	
5308	2751.261	427.57399	0.376415	28809.7886	25.362732	72.011492	69.977053	71.588651	83.044543	
5309	2751.772	426.56301	0.290277	37358.982	25.422843	71.999696	69.962685	71.569179	82.990432	
5310	2752.291	424.91547	0.271551	39935.2031	25.521416	72.123351	70.094568	71.740602	83.078218	
5311	2752.802	423.45516	0.211629	51242.8205	25.609428	72.085688	70.120005	71.715172	83.111964	
5312	2753.319	422.40673	0.166687	65058.8338	25.672992	72.034002	69.983373	71.666583	83.00505	
5313	2753.836	422.74372	0.219119	49491.1486	25.652526	72.100706	70.181109	71.729462	82.962884	
5314	2754.348	423.4926	0.286532	37847.2879	25.607164	72.21128	70.174052	71.799137	83.058436	
5315	2754.865	424.54103	0.335219	32350.3666	25.543925	72.130907	70.159722	71.793343	83.027671	
5316	2755.375	423.23049	0.237845	45594.6575	25.623023	72.051029	70.060144	71.683633	82.974514	
5317	2755.9	422.36928	0.174177	62261.0453	25.675268	72.010352	70.011321	71.711599	82.918382	
5318	2756.418	420.79663	0.271551	39935.2031	25.771224	72.071934	70.0495	71.721573	82.953768	
5319	2756.93	421.17107	0.368925	29394.7154	25.748313	72.157338	70.116644	71.769907	82.969191	

Fig 5.1—Automatically generated excel spreadsheet from recorded data

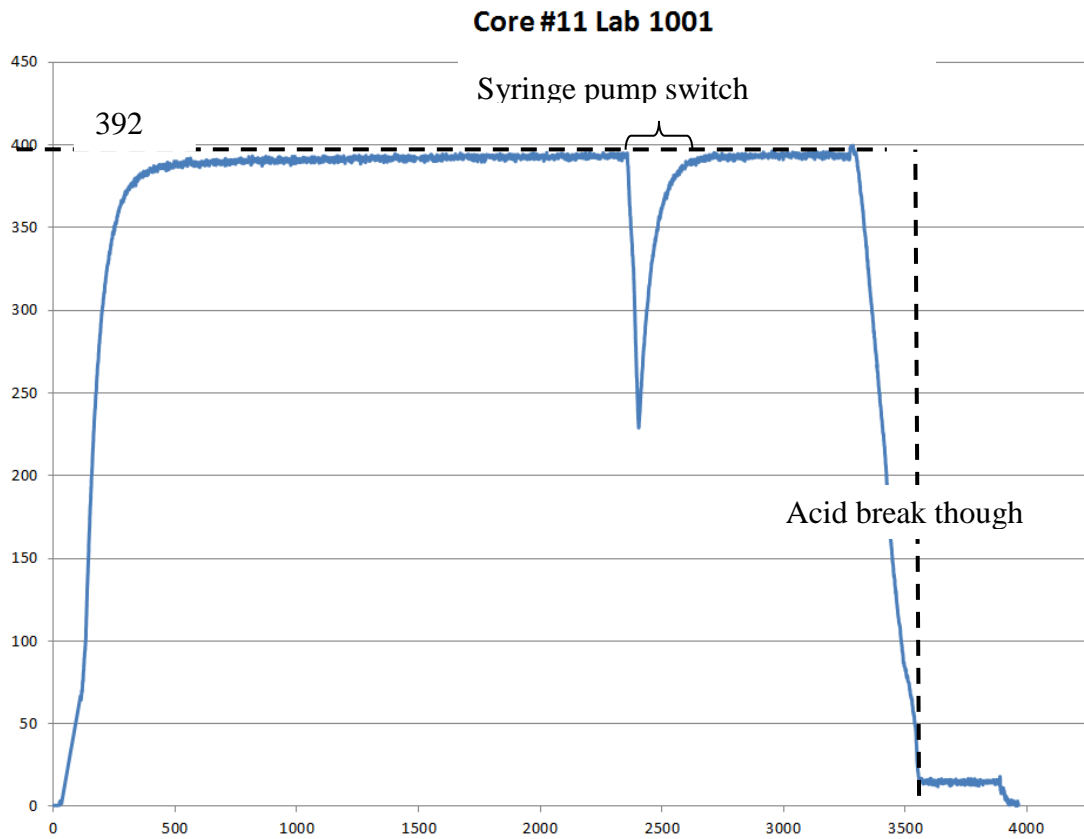

**Fig. 5.2—Pressure drop vs time graph data**

### 5.3 Calculations

#### 5.3.1 Porosity Calculation

Porosity is calculated before core flooding by measuring the core mass before and after saturation and applying the calculation below:

$$\phi = \frac{(\text{Mass}_{\text{wet rock}} - \text{Mass}_{\text{dry rock}})}{(2.54D)^2 * \frac{\pi}{4} * L * 2.54} * 100 = \frac{(688.9 - 625.1)}{(2.54 * 1.5)^2 * \frac{\pi}{4} * 10 * 2.54} * 100 = 15\% \quad (5.1)$$



### 5.3.2 Permeability Calculation

Permeability can be calculated when the steady state system has been reached indicated by a constant pressure drop across the core. A completely saturated core assures that the permeability being calculated is absolute permeability. With laboratory units, use the calculation below:

$$k = \frac{96.43 * 4 * q * L}{\pi * D^2 * \Delta P} = \frac{96.43 * 4 * 3.5 * 10}{\pi * 1.5^2 * 391} = 4.87 \text{ md} \quad (5.2)$$

### 5.3.4 Pore Volume to Breakthrough

Generating pore volume to breakthrough curves is beneficial in determining the optimum injection rate. By plotting pore volume to breakthrough ( $PV_{bt}$ ) on the x axis and interstitial velocity on the y-axis by varying injection rate, the optimum injection rate can be determined. A series of experiments is required to create this curve. Below are calculations for a single experiment:

Volume of tubing from accumulator to core:

$$\frac{\text{Length of pipe (cm)} * \pi}{4 * (0.12)^2} = \frac{193 \pi}{4 * (0.12)^2} = 2.18 \text{ cc} \quad (5.2)$$

Time for acid to reach the core:

$$\frac{\text{Volume of pipe (cc)} * 60}{\text{flowrate} \left( \frac{\text{cc}}{\text{min}} \right)} = 37.7 \text{ sec} \quad (5.3)$$

Pore volume:

$$PV = \phi * \frac{\pi}{4} * (D * 2.54)^2 * L * 2.54 = 43.8 \text{ cc} \quad (5.4)$$

Pore volume to breakthrough:

$$PV_{bt} = \frac{q \left( \frac{cc}{min} \right) * (\text{time of acid injection (s)} - \text{time acid to core(s)})}{60 \frac{sec}{min} * PV (cc)} = \frac{3.5 \left( \frac{cc}{min} \right) * (360 (s) - 37.4(s))}{60 \frac{sec}{min} * 43.8 (cc)}$$

$$= 0.43 \text{ pore volumes} \quad (5.5)$$

Interstitial Velocity:

$$v = \frac{q \left( \frac{cc}{min} \right)}{\pi * \phi * \frac{(D(in) * 2.54)^2}{4}} = \frac{3.5 \left( \frac{cc}{min} \right)}{\pi * 0.15 * \frac{(1.5(in) * 2.54)^2}{4}} = 2.03 \frac{cm}{min} \quad (5.6)$$

#### Coreflooding Data Sheet

<input type="checkbox"/> Core#	<u>11</u>	<input type="checkbox"/> Date	<u>April 29, 2012</u>
Core diameter	<u>1.5 inch</u>	<input type="checkbox"/> Acid Coreflooding	
Core length	<u>10 inch</u>	Temperature	<u>66 °F</u>
<input type="checkbox"/> Porosity Measurement		<input type="checkbox"/> Initial Pump Volume	<u>217.8 cm<sup>3</sup></u>
Weight (Dry)	<u>625.1 g</u>	Final Pump Volume	<u>195.8 cm<sup>3</sup></u>
Weight (Sat)	<u>668.9 g</u>	<input type="checkbox"/> Acid Injection Rate	<u>3.5 cc/min</u>
Porosity	<u>15%</u>	<input type="checkbox"/> Interstitial Velocity	<u>2.03 cm/min</u>
Pore Volume	<u>43.8 cm<sup>3</sup></u>	Volume of Pipe between Core and Acid tank	<u>2.18 cm<sup>3</sup></u>
<input type="checkbox"/> Permeability Measurement		Time for Acid to Get the Core	<u>37.4 seconds</u>
Injection Rate	<u>3.5 cc/min</u>	<input type="checkbox"/> Time for Acid Injection	<u>360 seconds</u>
Pressure Differential	<u>392 psi</u>	<input type="checkbox"/> Pore Volume Break Through	<u>0.43 Pore volume</u>
Permeability	<u>4.87 md</u>		
<input type="checkbox"/> Acid Formulation	<u>15 wt% HCl</u>		
Water	<u>465 cm<sup>3</sup></u>		
HCl (37 wt%)	<u>285 cm<sup>3</sup></u>		
Total Acid Volume	<u>750 cm<sup>3</sup></u>		

Fig 5.3—Experiment data sheet

## CHAPTER VI

### CONCLUSION

A matrix acidizing core flooding apparatus equipment description has been presented. The most significant features are the variation in core holder sizes, most notably being the 4'' X 20'' core holder; the high pressure and temperature rating; and the Hastelloy acid resistant material the main components were constructed out of. Also presented is a description of the data acquisition with a detailed explanation of the LabVIEW VI used to control and monitor temperature and recording pressure. A procedure was written for a basic matrix acidizing pore volume to breakthrough experiment. The procedure includes core saturation, apparatus preparation, brine injection for pressure build up, and acid injection. Also, a post acidizing analysis has been shown with relevant calculations. Both the procedure and apparatus can be modified for different applications.

## REFERENCES

- Economides, M.J., Hill, A.D., and Ehlig-Economides, C. 1994. *Petroleum Production Systems*. Englewood Cliffs, N.J.: PTR Prentice Hall.
- Frenier, W.W. and Hill, D.G. 2002. Effect of Acidizing Additives on Formation Permeability During Matrix Treatments. Paper presented at the International Symposium and Exhibition on Formation Damage Control, Lafayette, Louisiana. SPE-73705.
- Frick T.P., Mostofizadeh, B., Economides, M.J., 1994. Analysis of Radial Core Experiments for Hydrochloric Acid Interaction With Limestones. SPE- 27402.
- Furui, K., Burton, R.C., Burkhead, D.W. et al. 2010. A Comprehensive Model of High-Rate Matrix Acid Stimulation for Long Horizontal Wells in Carbonate Reservoirs. Paper presented at the SPE Annual Technical Conference and Exhibition, Florence, Italy. SPE-134265.
- Gomez, J.N. 2006. Design, Set-up, and Testing of a Matrix Acidizing Apparatus. Master of Science, Texas A&M University, College Station.
- Institution, A.P. 1998. Api - 40 Recommended Practices for Core Analysis. Porosity Determination Washington, D.C.
- Izgec, O., Keys, R.S., Zhu, D. et al. 2008. An Integrated Theoretical and Experimental Study on the Effects of Multiscale Heterogeneities in Matrix Acidizing of Carbonates. Paper presented at the SPE Annual Technical Conference and Exhibition, Denver, Colorado, USA. SPE- 115143.
- Keys, R. 2009. The Effect of Heterogeneity on Matrix Acidizing of Carbonate Rocks. M.S., Texas A&M University, College Station.
- Mostofizadeh, B., and Economides, M.J. 1994. Optimum Injection Rate from Radial Acidizing Experiments. Paper presented at the SPE Annual Technical Conference and Exhibition, New Orleans, Louisiana. SPE -28547.
- Mumallah, N.A. 1991. Factors Influencing the Reaction Rate of Hydrochloric Acid and Carbonate Rock. Paper presented at the SPE International Symposium on Oilfield Chemistry, Anaheim, California. SPE-21036.
- Wang, Y., Hill, A.D., and Schechter, R.S. 1993. The Optimum Injection Rate for Matrix Acidizing of Carbonate Formations. Paper presented at the SPE Annual Technical Conference and Exhibition, Houston, Texas. SPE- 26578.