

**SYSTEMIC SUBLINGUAL DELIVERY OF OCTREOTIDE ACETATE
UTILIZING LOW-CURRENT ORAL ELECTRICAL STIMULATION IN
RABBITS**

A Dissertation

by

CHRISTINA MARIE BOLCH

Submitted to the Office of Graduate Studies of
Texas A&M University
in partial fulfillment of the requirements for the degree of

DOCTOR OF PHILOSOPHY

August 2012

Major Subject: Biomedical Engineering

Systemic Sublingual Delivery of Octreotide Acetate Utilizing Low-Current Oral
Electrical Stimulation in Rabbits

Copyright 2012 Christina Marie Bolch

**SYSTEMIC SUBLINGUAL DELIVERY OF OCTREOTIDE ACETATE
UTILIZING LOW-CURRENT ORAL ELECTRICAL STIMULATION IN
RABBITS**

A Dissertation

by

CHRISTINA MARIE BOLCH

Submitted to the Office of Graduate Studies of
Texas A&M University
in partial fulfillment of the requirements for the degree of

DOCTOR OF PHILOSOPHY

Approved by:

Chair of Committee,	John C. Criscione
Committee Members,	Kenith Meissner
	Michael R. Moreno
	Maya Scott
Head of Department,	Gerard L. Cote

August 2012

Major Subject: Biomedical Engineering

ABSTRACT

Systemic Sublingual Delivery of Octreotide Acetate Utilizing Low-Current Oral
Electrical Stimulation in Rabbits. (August 2012)

Christina Marie Bolch, B.S., Texas A&M University;

M.E., Texas A&M University

Chair of Advisory Committee: Dr. John C. Criscione

A sublingual electronic pill is a novel device designed to enhance delivery of drugs/biologics sublingually utilizing low-current electrical stimulation. Our primary aim was to explore safe limits of oral electrical stimulus in animals and conduct a randomized, sham-controlled animal study to quantify benefits of electrical stimulation on sublingual absorption of octreotide (a small peptide) as a first step in the development of this technology.

A system to deliver low-current alternating and direct current stimuli to the oral mucosa of rabbits was constructed, and five groups were studied to determine the significance of sublingual octreotide diffusion in the presence of three different electrical stimulation scenarios: +DC (+4 mA), -DC (-4 mA), and AC (2 mA peak-to-peak, 20 Hz square wave). These were compared to an Oral Baseline Absorption Group (sublingual diffusion in the absence of stimulation) to determine statistical significance of electrical stimulus; and a Subcutaneous Control Group (bolus injection) to discern therapeutic significance.

+DC stimulation (4mA) increased serum concentration 28x with high statistical significance (p-value=0.0008). -DC stimulation (-4mA) increased serum concentration by 19x with borderline significance (p=0.032). AC (20 Hz) stimulus (2mA peak-peak) increased serum concentration by 10x, but was not statistically significant.

The absorption rate of octreotide was also calculated for each group and compared at t=10 minutes and t=30 minutes. The absorption rate of the +DC group was 28x greater than that of Baseline Group and was statistically significant (p=0.0008). The absorption rate of the -DC group was 19x greater than that of the Baseline Group and was statistically significant (p=0.032). The absorption rate of the AC group was 10x greater than the Baseline Group but was not statistically significant (p=0.135).

While none of the sublingual groups reached therapeutically significant serum concentrations, therapeutic levels of sublingually-delivered octreotide could potentially be achieved by extending octreotide exposure and stimulation time, coupled with utilizing sublingual octreotide in higher concentrations. This research was a necessary first step in successful realization of the SEP device.

DEDICATION

I would like to dedicate my doctoral dissertation to my family, especially my parents, Greg and Wendy Nazzal, and my husband, Aaron Bolch, for their continued love and support; to my siblings, Natalie, Alex, and Eric Nazzal for their love and comic relief; and to my grandma, Geraldine C. Mayer, for being such an inspiration to women in mathematics and engineering – I love and miss you.

ACKNOWLEDGEMENTS

I'd like to thank my committee members first and foremost for their contributions and guidance, especially Dr. Criscione for all the years of invaluable experience and guidance. Thanks to Mike Moreno and Dr. Meissner for their guidance and support throughout my undergraduate and graduate careers, and to Dr. Scott for her support and contributions to this project.

I'd also like to thank the staff at LARR who helped conduct these experiments: Betsy Browder, Andrea Taylor, Vince Gresham, and Ryan Byrd. I'd also like to thank Erwin Thomas III in the TAMU Physics Shop for guidance in the development of my electrical system, as well as Stephen Lagutchik at the TAMU Veterinarian Medial Teaching Hospital GI Lab for performing our RIA analysis.

Thanks to my friends and family for their love and support throughout my nine year career as a professional student.

NOMENCLATURE

AAALAC	Association for the Assessment and Accreditation of Laboratory Animal Care, International
AC	Alternating Current
AD620	Instrumental amplifier
ARO	Army Research Office
AUP	Animal Use Protocol
BNC	Bayonet Neill-Concelman/British Naval Connector
BV _r	Blood volume (rabbit)
BV _h	Blood volume (human)
BW _r	Rabbit body weight
C ₀	Initial concentration
C ₃₀	Concentration at 30 mins
cpm	Counts per minute
DARPA	Defense Advanced Research Projects Agency
DC	Direct Current
FDA	Food and Drug Administration
Hz	Hertz
IACUC	Institutional Animal Care and Use Committee
IM	Intramuscular
I _r	Current across the rabbit
k	Elimination rate constant

k Ω	Kilohms
LARR	Laboratory Animal Resources and Research Facility
LM741	Operational amplifier
mA	Milliamperes
MCGs	Membrane Coating Granules
mcg	Micrograms
ml	Milliliters
ms	Milliseconds
μ s	Microseconds
pH	Potential Hydrogen
PI	Principal Investigator
R _G	Gain resistor
RIA	Radioimmunoassay
RNA	Ribonucleic Acid
R _r	Resistance of rabbit
SEP	Sublingual Electronic Pill
SPF	Specific Pathogen Free
Stim	Stimulation/stimulated
SubQ	Subcutaneous
T	Period (for alternating current)
t _{1/2}	Half-life
TAMU	Texas A&M University

v	Volts
Vd	Volume of distribution
Vdh	Volume of distribution (human)
Vdr	Volume of distribution (rabbit)
Vin	Voltage input into Precision Current Source
VIPoma	Vasoactive intestinal peptide-oma
Vr	Voltage across the rabbit
Vs	Voltage source for instrumental amplifier

TABLE OF CONTENTS

	Page
ABSTRACT.....	iii
DEDICATION.....	v
ACKNOWLEDGEMENTS.....	vi
NOMENCLATURE.....	vii
LIST OF FIGURES.....	xii
LIST OF TABLES.....	xiv
1. INTRODUCTION: THE NEED FOR A SUBLINGUAL ELECTRONIC	
PILL DEVICE.....	1
1.1 Motivation for Department of Defense Sponsorship Study.....	1
1.2 Challenges of Systemic Protein and Peptide Delivery.....	4
1.3 Transport and Storage Advantages.....	5
2. OVERVIEW OF TRANSEPITHELIAL DRUG DELIVERY.....	6
2.1 Transdermal Drug Delivery.....	6
2.2 Transmucosal Drug Delivery.....	8
2.3 Orotransmucosal Drug Delivery.....	8
3. OVERVIEW OF ELECTRICAL STIMULATION IN MEDICINE AND	
MEDICAL DEVICES.....	12
3.1 Transdermal Electrical Stimulation.....	12
3.2 Orotransmucosal Electrical Stimulation.....	14

	Page
4. DEVELOPMENT OF AN ELECTRICAL SYSTEM TO DELIVER LOW-CURRENT DC AND AC STIMULI TO THE ORAL MUCOSA OF RABBITS.....	16
4.1 System Requirements.....	16
4.2 System Construction	18
4.3 System Limitations	23
5. EXPERIMENTAL PROTOCOL TO TEST EFFICACY OF SUBLINGUAL DRUG DELIVERY UTILIZING LOW-CURRENT DC AND AC STIMULI TO THE ORAL MUCOSA OF RABBITS	24
5.1 Test Animal Study	24
5.2 Octreotide Absorption Study Protocol.....	26
6. ASSESSMENT OF ORAL LOW-CURRENT DC AND AC STIMULI ON SUBLINGUAL DIFFUSION OF OCTREOTIDE INTO THE BLOOD STREAM OF RABBITS.....	37
6.1 Radioimmunoassay Analysis.....	38
6.2 Results.....	39
6.3 Discussion	63
6.4 Limitations	69
7. CONCLUSIONS.....	71
7.1 Funding	72
7.2 Consultants.....	72
REFERENCES	74
VITA.....	80

LIST OF FIGURES

FIGURE	Page
1 Skin Epithelium Structure.....	7
2 Voltage-Controlled Current Source Schematic	19
3 Electrical Stimulation System Set Up.....	20
4 Oral Electrode	20
5 Oscilloscope Reading on Test Load	21
6 Precision Current Source Load Resistance vs. Voltage.....	22
7 Serum Separator Tube Containing Blood Sample	30
8 Animal Set Up.....	32
9 Centrifuge	36
10 +DC Vr Oscilloscope Image.....	40
11 AC Vr Oscilloscope Image	40
12 Baseline Oral Absorption Group Octreotide Serum Concentrations.....	43
13 +DC Stim Serum Octreotide Concentrations.....	44
14 -DC Stim Serum Octreotide Concentrations.....	45
15 AC Stim Serum Octreotide Concentrations	46
16 Average Sublingual Octreotide Serum Concentrations	47
17 Baseline Oral Absorption Octreotide Absorption Rates.....	51
18 +DC Stim Octreotide Absorption Rates	52
19 -DC Stim Octreotide Absorption Rates	53

FIGURE	Page
20 AC Stim Octreotide Absorption Rates.....	54
21 Average Sublingual Octreotide Absorption Rates	55

LIST OF TABLES

TABLE	Page
1 Baseline Oral Absorption Group Serum Octreotide Concentration Data.....	43
2 Positive DC Stimulus Group Serum Octreotide Concentration Data	44
3 Negative DC Stimulus Group Serum Octreotide Concentration Data.....	45
4 AC Stimulus Group Serum Octreotide Concentration Data	46
5 Baseline Oral Absorption Group Octreotide Absorption Rates.....	51
6 Positive DC Stimulation Group Octreotide Absorption Rates	52
7 Negative DC Stimulation Group Octreotide Absorption Rates	53
8 AC Stimulation Group Octreotide Absorption Rates	54
9 Subcutaneous Injection Group Calculated Octreotide Serum Concentrations at 30 mins.....	59
10 Comparison Between Sublingual Diffusion Groups Serum Octreotide Concentrations and Known Therapeutic Serum Concentration.....	67

1. INTRODUCTION: THE NEED FOR A SUBLINGUAL ELECTRONIC PILL DEVICE

A sublingual electronic pill (SEP, SEP Technologies, Inc.) is a novel device that is designed to enhance the delivery of drugs and/or biologics in a sublingual transmucosal format with the aid of low-current electrical stimulation. This device may be capable of eliminating the need for intravenous injections and their associated discomfort and challenging supply logistics. This research is a first step in the development of this technology. The primary aim of this research was to explore the safe limits of oral electrical stimulus in animals and conduct a prospective, randomized, sham controlled, animal study to quantitatively establish the benefit of electrical stimulation on absorption of octreotide acetate (a small peptide).

1.1 Motivation for Department of Defense Sponsorship Study

Many biologics, such as small interfering RNA and monoclonal antibodies, cannot be administered orally (ingested) to the human body without being degraded and/or denatured by the digestive tract and/or liver.^{1,4,28,29} Traditionally, these types of biologics are administered to subjects as injectables; however, there exist certain

This dissertation follows the style of *Annals of Biomedical Engineering*.

situations or conditions in which injection of biologics is not feasible or preferred, including drug delivery on the battlefield and in biological warfare. By having such therapies in a readily consumable and easily transportable format, soldiers will be better prepared to respond to pathogen exposure thereby minimizing the spread of illness and death from deadly biological warfare agents such as anthrax, nerve agents, smallpox, and Ebola. On a broader scale, patients taking biologics or drugs for ailments such as cancer and autoimmune diseases will benefit from alternatives to intravenous injections.^{1,4,28,29}

Octreotide Acetate

An FDA advisor to SEP Technologies suggested octreotide acetate as a first candidate for clinical testing because it is a positively charged, hydrophilic molecule that is likely to have low baseline bioavailability and because pilot data on octreotide suggests that it will be useful for clinical trial planning. Octreotide acetate is an octapeptide analogue of the hormone somatostatin.⁷ It is more stable in the body than the natural hormone, and consequently has a longer half-life in the body than somatostatin,³² rendering octreotide more clinically relevant than naturally occurring somatostatin. Though octreotide was initially developed to treat carcinoid tumors and VIPomas¹⁵ (vasoactive intestinal peptide-omas; a rare endocrine tumor, usually originating in the pancreas), it has been found to be capable of modulating gastrointestinal functions by reducing gastric acid secretion, delaying stomach emptying, and slowing intestinal motility,²⁴

which is beneficial in treating side effects of chemotherapy in cancer patients. Octreotide is currently approved by the FDA to treat acromegaly (a syndrome that results when the anterior pituitary produces excess growth hormone after puberty), flushing (redness of the face) and diarrhea in patients with carcinoid syndrome and VIPomas.

Initial dosage of octreotide in patients with diarrhea associated with chemotherapy is 100-150 mcg every eight hours subcutaneously.^{9,23} For severe diarrhea, this may be increased to 500-1500 mcg intravenously or subcutaneously every eight hours.²³ Complicated cases may require an initial dosage of 100-150 mcg three times per day or an I.V. infusion of 25-50 mcg/hour; this may be increased to 500 mcg three times per day until controlled.⁹

When octreotide is administered subcutaneously in humans, it reaches its peak plasma concentration within 30 minutes. Plasma concentrations are dose-dependent and linear. Octreotide, when administered parentally, has an absolute bioavailability of approximately 100% and a half-life of approximately 1.7 - 1.9 hours in patients with a healthy liver and kidneys.²⁴ When a 100 mcg dose of octreotide is administered in humans, a peak plasma concentration of 5.2 ng/ml is reached in approximately 25 minutes (Clinical Pharmacology Online Database).

Due to poor oral bioavailability, octreotide must be delivered parenterally. This characteristic, in conjunction with the fact that it is typically administered to patients in

a chronic manner, makes it an ideal candidate for potential orotransmucosal drug delivery. Because octreotide is a relatively small peptide made up of eight amino acids and has a positive charge in saliva, it is a good candidate to test whether systemic peptide delivery across the oral mucosa can be enhanced by electronic stimulation.

1.2 Challenges of Systemic Protein and Peptide Delivery

Successful therapeutic utilization of peptides and proteins depends on the ability to administer them in an efficient and patient-compliant manner. Oral delivery (ingestion) of peptides and proteins is rarely feasible due to their enzymatic and acidic instability in the gastrointestinal tract, as well as their pre-systemic hepatic metabolism (first-pass phenomena).²⁷ (Lee and Yamamoto, 1990). Consequently, constituents not suitable to ingestion are typically delivered systemically via parenteral routes of administration (e.g., subcutaneous, intravenous, or intramuscular injection). Research efforts have been directed towards exploring alternate delivery routes for peptide- and protein-based pharmaceuticals to increase patient safety and compliance², as well as address transport and storage logistics associated with injectable pharmaceuticals (liquids). Potential alternate routes of systemic protein and/or peptide administration include transdermal, nasal, orotransmucosal, ocular, rectal, and vaginal, all of which bypass potential digestion in the gastrointestinal tract and clearance by the liver prior to reaching systemic circulation.⁶

1.3 Transport and Storage Advantages

Another benefit to administering drugs and biologics via the oral mucosa is that the drug/biologic can be transported, stored, and administered in its solid form. Drugs and biologics in liquid form (injectables) are unstable and challenging to store and transport since variables such as temperature and light exposure must be taken into account. By administering drugs orally, the solid form of the drug can be utilized since the saliva dissolves the drug into a suspension at the time of drug administration.

2. OVERVIEW OF TRANSEPITHELIAL DRUG DELIVERY

Sublingual administration is a type of transepithelial drug delivery. This section is a review of the literature for this route of drug administration.

2.1 Transdermal Drug Delivery

The skin is made up of the epidermis and the dermis, which forms the cutis. Located above the dermis, the epidermis consists of a stratified squamous epithelium and, on average in humans, measures approximately 40-50 microns in thickness, but varies greatly between subjects, location on the body, age, and gender.⁴¹ The epidermis consists of five distinct zones of cells in varying degrees of differentiation. Located right above the basal lamina is the stratum basale, which is made up of mitotically active cells. After division, these epithelial cells begin to differentiate and migrate towards the skin's surface, becoming a part of the stratum spinosum, stratum granulosum, stratum lucidum, and eventually the stratum corneum (Fig. 1), which is located at the skin's surface.¹⁰

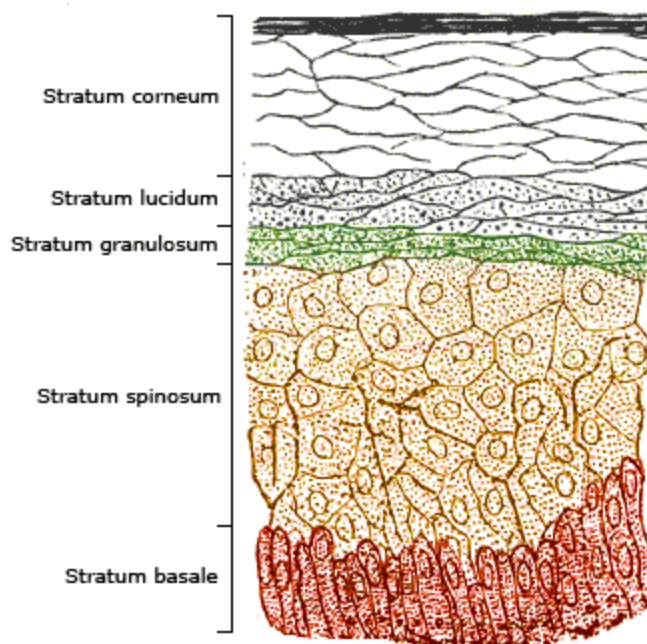


Figure 1: Skin Epithelium Structure. From Wikipedia (public content)

The barrier properties of skin lie mostly in this uppermost layer, the stratum corneum,³⁴ which consists of differentiated, lamellar, non-nucleated (keratinized) cells or corneocytes which are filled with keratins and embedded in a lipid domain. This layer is considered to be the rate-limiting step for skin absorption of most molecules.¹⁷ The stratum corneum is approximately 8-13 microns thick in humans and is made up of about 15-23 cell layers, which varies between individuals and sample location.²⁰ Stratum corneum thickness and rate of transdermal diffusion are inversely related.²⁰ The stratum corneum, along with the rest of the epidermis, allows some

pharmaceuticals (particularly lipophilic particles) to pass via passive intercellular diffusion amongst the extracellular lipids.¹⁰

There are a few pharmaceuticals that are well-suited to transdermal drug delivery; however, since there are many specific parameters that make a drug conducive to this route of systemic delivery - including aqueous solubility, lipophilicity, molecular weight, melting point, pH, and therapeutic dose - there remains a large pool of drugs for which transepithelial delivery is desirable, but presently unfeasible due to the excellent barrier properties of the stratum corneum.³¹

2.2 Transmucosal Drug Delivery

Transmucosal routes of drug delivery include intraoral, nasal, ocular, rectal, and vaginal. Nasal and intraoral routes of administration are the most accepted by the patient; however, prolonged use of the nasal route may cause damage to the mucosal cilia. Orotransmucosal drug delivery is thought to be the least damaging to the local epithelia, while having the highest patient compliance.³⁷ The orotransmucosal route is the drug delivery method examined in these studies.

2.3 Orotransmucosal Drug Delivery

Systemic drug delivery via the intraoral membranes would address issues with pre-systemic metabolism both in the gastrointestinal tract and the liver²⁷ while overcoming

barrier issues encountered by transdermal drug delivery. Regions in the oral cavity where pharmaceuticals can be effectively administered (both locally and systemically) are buccal, sublingual, palatal, and gingival. Of these, the buccal and sublingual routes are the most commonly used due to physical properties which make them more amenable to transmucosal drug delivery.²⁶ Both surfaces are composed of stratified squamous non-keratinized epithelia, meaning they lack the barrier layer (stratum corneum) encountered in skin. The sublingual mucosa is thinner and more permeable than the buccal mucosa, making it ideal for quick delivery of pharmaceuticals.²⁶ Other advantages of orotransmucosal drug delivery include ease of access, low enzymatic activity, and tolerance to absorption enhancers.²⁷

One challenge encountered with sublingual drug delivery is effectively keeping the dosage in contact with the mucosa due to constant washing by saliva and tongue activity.²⁶ A sublingual device, such as the Sublingual Electronic Pill, can help to alleviate this problem since the device presses the pharmaceutical agent against the sublingual mucosa through the downward action of the patient's tongue on the device.

To be successfully delivered transmucosally, substances must have a proper balance between aqueous solubility and lipophilicity. Even drugs that are well-suited to transmucosal drug delivery can only be delivered a few milligrams at a time.²⁶ Studies have shown that the main permeation barrier is membrane coating granules (MCGs),

which are found in keratinized and non-keratinized epithelia.²⁶ The components of MCGs differ between keratinized and non-keratinized epithelia.²⁶

There are three very distinct and necessary phases of substance diffusion across the oral epithelium. First, the compound must dissolve and disperse into the saliva. It must then cross the unstirred water layer consisting of a mucin network at the epithelial surface, and lastly, the drug crosses the oral mucosa.²³ Often, the aid of absorption enhancers is needed to achieve a systemic therapeutic level of larger hydrophilic peptides.^{23,35} For smaller lipophilic peptides, dissolution enhancers are often needed to achieve the aforementioned first phase of substance diffusion across the oral mucosa.²³

Some peptides and proteins are readily absorbed across the oral mucosa via passive paracellular diffusion; however, as compared to injection, transmucosal drug delivery to the systemic blood stream is vastly less efficient.³⁷ In order to efficiently utilize this convenient route of systemic drug delivery, the potential systemic bioavailability of the administered drug must be improved upon. Bioavailability of drugs administered sublingually has been moderately increased versus diffusion alone by utilizing various bioadhesion-enhancing molecules;³⁷ however, bioavailability still remains vastly substandard as compared to parenteral routes of administration.³⁷

Preliminary unpublished research by SEP Technologies has shown that low-level electronic stimulation of the sublingual mucosa causes an increase in blood flow and an increased porosity in the mucosal tissues (SEP Technologies, Inc. DARPA grant

proposal). Hence, transmucosal electrical stimulation may provide a convenient and effective manner by which to increase systemic peptide bioavailability via transmucosal diffusion in a way that is therapeutically significant.

3. OVERVIEW OF ELECTRICAL STIMULATION IN MEDICINE AND MEDICAL DEVICES

Electrical stimulation of oral mucosa to increase absorption of bioactive agents is a recent use of electricity in medical devices. This section is a review of electrical stimulation devices.

3.1 Transdermal Electrical Stimulation

The earliest use of transdermal electrical current appears to be about 5000 years ago.³³ Greek and Roman physicians utilized electric fish capable of generating 100-150 volts of electricity applied to the skin for the treatment of ailments such as headache, arthritis, and hemorrhoids.³³ Although electricity has been used over the centuries to cure a variety of ailments, the modern era of utilization of electricity in medical applications did not begin until the nineteenth century, by which time most American physicians possessed at least one electrotherapeutic machine.³³

Today, therapeutic and diagnostic applications of electrical stimulation in medicine are widespread.³³ Amongst the extensive usages of electricity in medicine, application of an electric current to skin has been found to be beneficial in transdermal drug delivery, primarily in the form of iontophoresis.^{5,12,22,33,38,39,40} Iontophoresis is defined as a facilitated movement of charged compounds into or across a membrane in the presence of an externally applied electrical potential across the membrane.²¹ While iontophoretic

applications usually employ a direct DC current, pulsed DC waveforms and alternating currents are occasionally utilized.¹²

The mechanisms underlying electrically-induced changes in the skin's electrical properties are not fully understood. Applying a current may alter the skin's ion concentration, decreasing the skin's resistance.³³ Electric field-induced electroosmosis may also play a role in the skin's decreased resistance in the presence of an electric current.³³ This reduction in skin resistance is often related to an increase in skin permeability.³³ This decrease in skin resistance may be explained by the reorientation of lipid structures within the epithelium during electrical stimulation since skin lipids are a significant barrier to transdermal ion transport.³³

Electroporation, which is usually caused by a short (10 μ s to 10 ms), high-voltage (transmembrane voltage of ~ 1 v) electric field pulse, may be involved in the creation of transient aqueous pathways in lipid bilayers, resulting in structural changes in stratum corneum lipids.³³ Electroporation has been found to reversibly increase permeability in both metabolically inactive systems (e.g., liposomes) and in living cells by many orders of magnitude. The reduction in resistance in the epithelium seen at low voltages and without any changes in skin structure may be explained by a mechanism involving convective transport by electroosmosis.^{18,33}

In general, iontophoretic increases in diffusion of charged compounds across a membrane is thought to act primarily by electroosmosis and electrorepulsion, which occurs when an electric field repels compounds of like charges.^{18,21,30}

3.2 Orotransmucosal Electrical Stimulation

Iontophoretic applications in the oral mucosa are relatively novel and still require additional investigation to better understand the underlying mechanisms of action and to maximize efficiency. Buccal and sublingual drug delivery has seen several advances in the last 5 years,³⁶ with a favorable outlook on the future of potential buccal and sublingual delivery systems.³⁶ It is also expected that physical means of enhancing oro-transmucosal drug delivery, such as sonophoresis, iontophoresis, and electroporation, will be commercialized for buccal drug delivery.³⁶ According to Senel, buccal and sublingual delivery, in general, is attractive for the development of intellectual property.

Most studies on the effects of iontophoresis in the oral mucosa have been performed on the buccal mucosa; electroosmotic effects, electrorepulsion effects, and a decrease in mucosal resistance over time have been demonstrated in excised pig cheek; however, these results are local in nature (versus systemic).^{14,16,21,30}

In Europe, animal studies have shown success of buccal transmucosal delivery of naltrexone in pigs capable of delivering therapeutic plasma levels of drug while

avoiding spikes in blood levels associated with IV delivery.¹¹ This research is being conducted in the development of a buccal transmucosal drug delivery device, called “IntelliDrug”. However, the “IntelliDrug” device can only be utilized in patients who are missing two side-by-side molars due to device size and placement.^{13,35} Additionally, peptide drugs cannot diffuse across the oral mucosa unaided; therefore, studying the effects of iontophoretic delivery on such molecules would be significant in the development of iontophoretic orotransmucosal technologies.¹³

Considering the mechanisms referenced in Section 3.1 and the unpublished study by SEP, Inc. (mentioned in Section 2.3), we believe that the application of an electrical stimulus across the sublingual mucosa may result in an increase in the sublingual delivery of octreotide acetate into systemic circulation. This may occur due to one or multiple mechanisms associated with epithelial electrical stimulation within the range of applied currents (approximately 7 mA) and waveforms (20 Hz square wave [T=5 ms] and direct current) associated with our experimental setup, including: an increase in local capillary blood flow; a reduction in epithelial resistance; an increase in epithelial permeability; and an increase in ion (electrorepulsion) and water movement (electroosmosis) in the mucosa.

4. DEVELOPMENT OF AN ELECTRICAL SYSTEM TO DELIVER LOW-CURRENT DC AND AC STIMULI TO THE ORAL MUCOSA OF RABBITS

Electrical stimulation is thought to act in two ways to increase drug absorption across the mucous membrane: 1) via a net electrical field (DC current) across the mucous membrane to increase diffusion of a charged molecular drug entity across the membrane, and 2) via alternating current stimulation to open up capillaries and cellular pores and thus increase absorption into the blood stream (correspondence with Yossi Gross, founder of SEP Technologies, Inc.). Our study was designed in such a way that both components will be tested individually.

4.1 System Requirements

In order to test the hypothesis that electrical stimulation increases systemic bioavailability of octreotide via sublingual transmucosal delivery versus diffusion alone, a system with which to deliver and measure an electrical stimulus across the oral mucosa of rabbits needed to be conceptualized and fabricated. Specifications of this system included capabilities of delivering a known current and waveform to the test subject in a reliable manner when a known voltage/waveform is input into the system.

We planned to deliver a direct current of +8 mA and -8 mA to Direct Current Test Subjects and a square wave of 8 mA peak-to-peak at a frequency of 20 Hz to Alternating Current Test Subjects. These parameters were chosen based on preliminary unpublished studies by SEP Technologies, Inc. that show that this amount of current and frequency are typically low enough to be safe to patients while still delivering a therapeutic level of electrical stimulation. The system also needed to be adjustable on the order of tenths of a volt since we were not certain how test subjects would react to electrical stimulation. The system also needed to possess the capability to cease stimulation at any time should a test subject react adversely (defined by exaggerated muscle twitching and/or muscle tetany, or other adverse unforeseen reactions). The system was also required to be portable since it needed to be transported between facilities/test subjects. The system needed to have capabilities to measure, record, and verify input waveforms/voltages and the waveforms/currents across the test subject.

4.2 System Construction

A voltage-controlled current source was chosen to be part our electrical stimulation device (Fig. 2). This circuit allowed us to input a known voltage into the circuit and provide a voltage to the test load that is proportional to the input. This circuit allowed the user to set and adjust this gain between the input current and the current across the test subject depending on which resistor values were chosen in our circuit – we chose to construct this circuit with a gain of 1 (i.e., input voltage is equal to the voltage across the test load) by leaving R_G open (or infinite resistance) and by choosing resistors for the circuit based on an assume load resistance of $1k\Omega$ since this has been found to be a good estimate of the resistance of wet skin.³³ We utilized an AD620 instrumental amplifier³ which is low-cost, low-power, highly accurate, and capable of providing a precision current source when implemented in conjunction with an LM741 operational amplifier, resistors, an input power source, and an amplifier power source. This circuit and components were chosen after consideration of our desired output currents and frequency, and consultants in the TAMU Physics Department Electronics Shop recommended it as a very precise and reliable circuit with which to deliver a constant low-current stimulation to test subjects.

Our stimulation system consisted of a power source, the aforementioned precision current source, a function generator, and an oscilloscope, along with basic electrical components (wires, resistors, BNC adaptors, alligator clips, etc.; Fig. 3). The output pin of the circuit was attached via alligator clips to the oral electrode (Fig. 4) which would be inserted around the tongue of the test subjects. The function generator was utilized to input specified voltages and waveforms into the circuit (e.g., +8 V, -8 V, and a 20 Hz square wave 8 V peak-to-peak) to elicit the desired currents and waveforms across the oral mucosa of the test subjects (e.g., +8 mA, -8 mA, 20 Hz square wave 8 mA peak to peak).

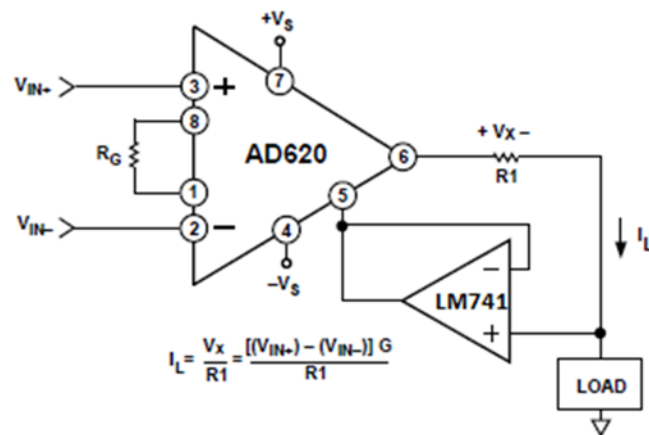


Figure 2: Voltage-Controlled Current Source Schematic.

Voltage-controlled current source schematic utilizing an AD620 instrumental amplifier in conjunction with an LM741 operational amplifier. From the AD620 Datasheet PDF³

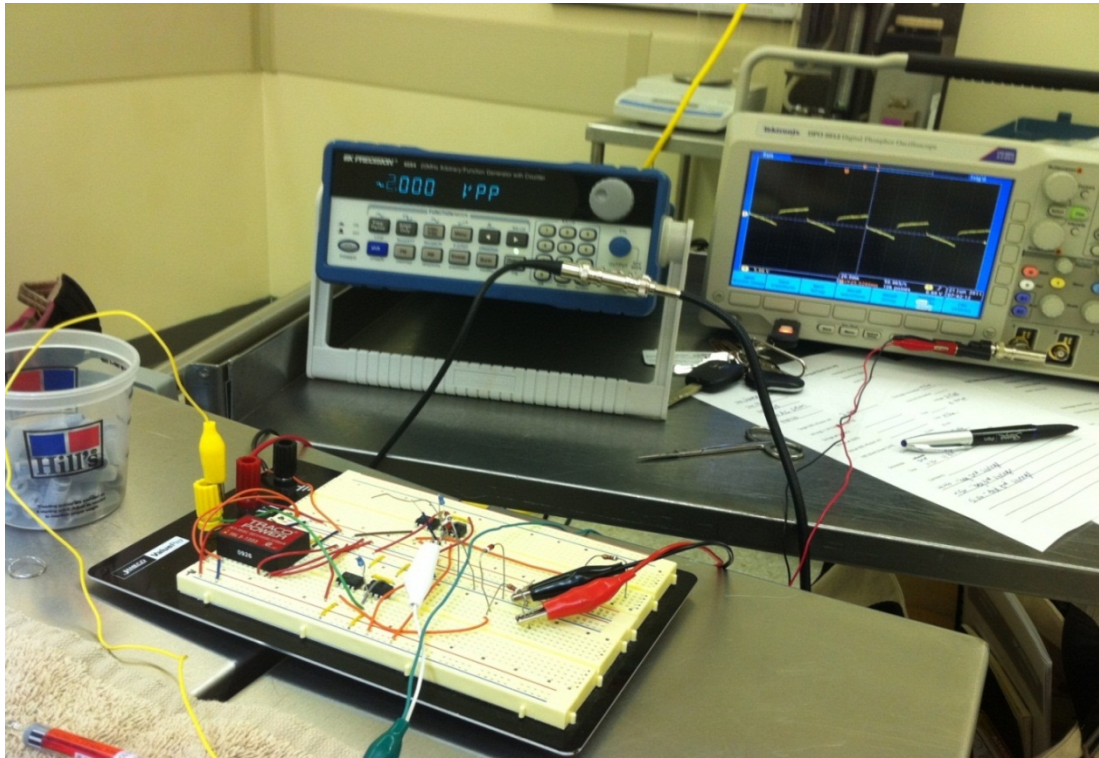


Figure 3: Electrical Stimulation System Set Up. Electrical stimulation system to deliver low-current AC and DC stimuli to the oral mucosa of rabbits. Top left: function generator to generate input waveform into the precision current source circuit; Top right: Oscilloscope to measure waveform actually delivered to test subject; Lower left: precision current source circuit.



Figure 4: Oral Electrode. Oral electrode constructed out of stainless steel suture; circular portion to be positioned around the tongue of the test subject, straight end attached to output pin of the precision current source via alligator clip.

The system was first tested using a 1 k Ω resistor as a test load to determine approximate voltage input ranges for the test subjects, as well as to verify desired output currents (Fig. 5). We also tested the system with increasing test loads (0.5 k Ω - 8 k Ω) to verify the range of resistances in which the system behaved as desired. From this, we found that the system was capable of delivering an output current (4 mA) that was proportional to the input voltage (4 v) up to a load resistance of approximately 3.5 - 4 k Ω (Fig. 6).

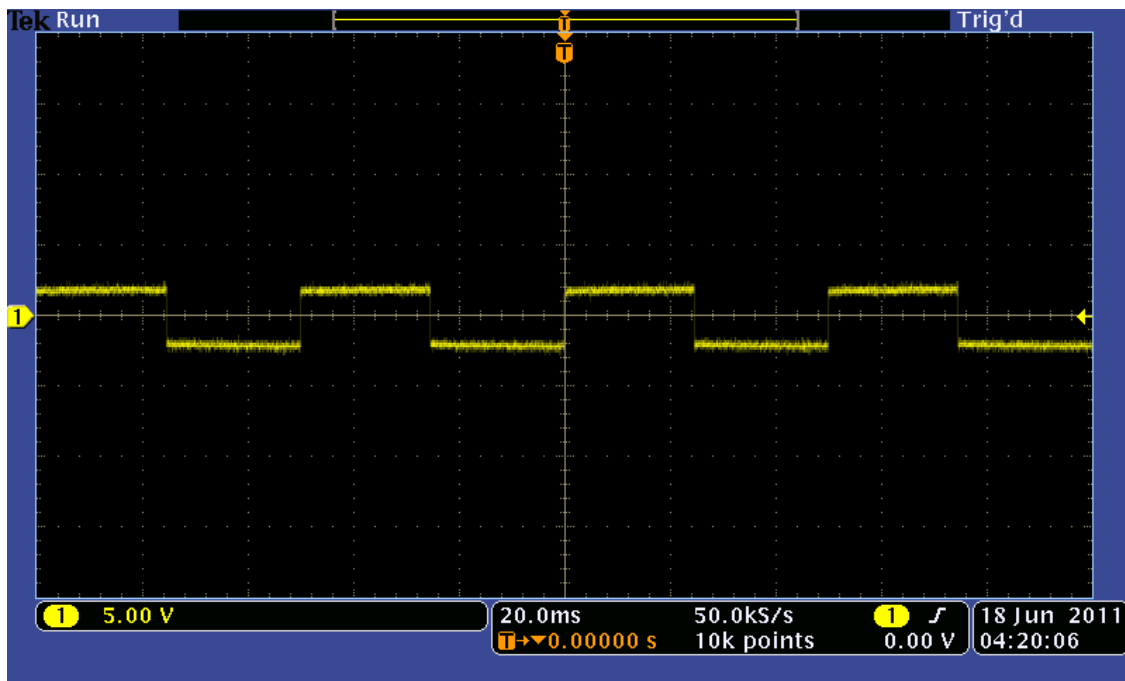


Figure 5: Oscilloscope Reading on Test Load. AC Square Wave (20 Hz) oscilloscope reading for a test resistance of 1 k Ω .

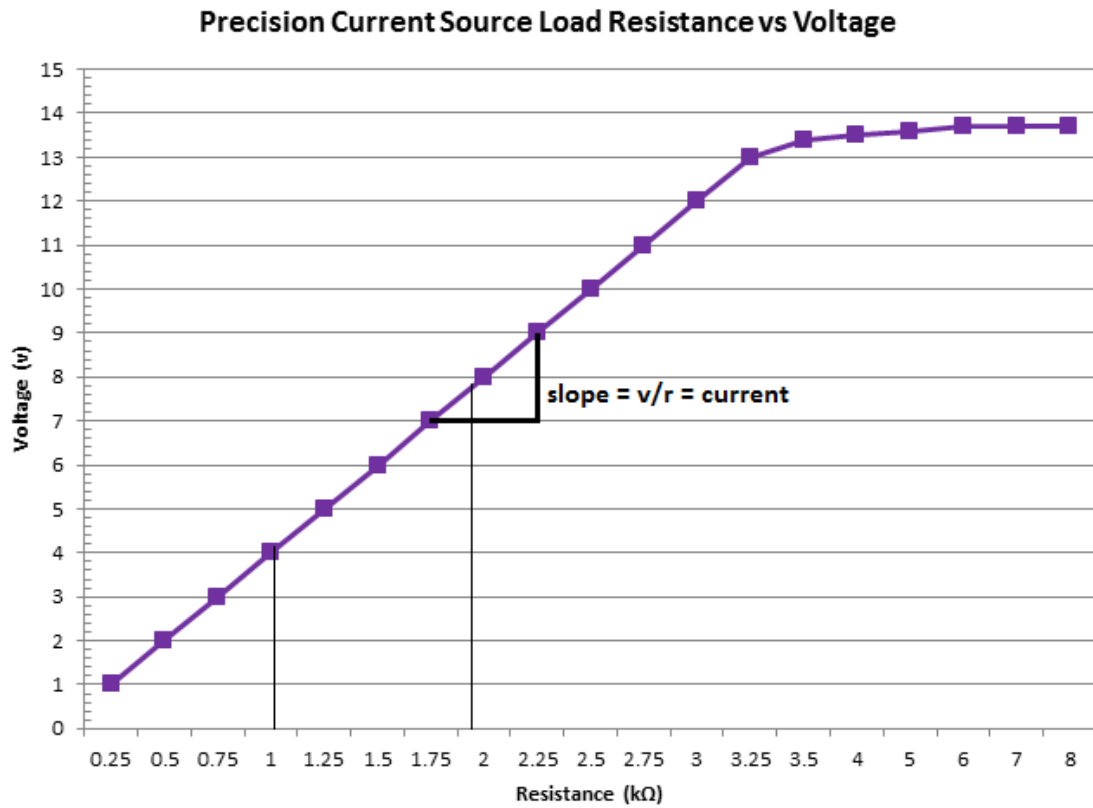


Figure 6: Precision Current Source Load Resistance vs. Voltage. Test load resistance vs load voltage. Circuit is able to deliver desired currents to load resistances up to approximately 3.5 – 4 kΩ. Rabbits are expected to have a resistance between 1-2 kΩ.

The oscilloscope was used to visualize the input voltages and waveforms from the function generator, as well as the output currents and waveforms across the test load and/or test subject in real time to verify that the proper electrical stimulation was delivered to the test subjects.

4.3 System Limitations

We did not know our actual load resistance (rabbit mucosa) until we utilized the device on the animal; therefore, we had to construct the electrical circuit based on an estimated test load resistance. Additionally, a resistor alone is not an accurate representation of the impedance of the test subject due to the body's capacitive characteristics; however, it was determined to be within an acceptable tolerance for this experiment.

5. EXPERIMENTAL PROTOCOL TO TEST EFFICACY OF SUBLINGUAL DRUG DELIVERY UTILIZING LOW-CURRENT DC AND AC STIMULI TO THE ORAL MUCOSA OF RABBITS

All animal experiments were performed under an Animal Use Protocol (AUP) approved by the Texas A&M University Institutional Animal Care and Use Committee (IACUC). Twenty-five specific pathogen free (SPF) female New Zealand White (NZW) rabbits were purchased from Harlan Laboratories for this study. They were housed in the Texas A&M University central vivarium, which is a part of the institutional accreditation by the Association for the Assessment and Accreditation of Laboratory Animal Care, International (AAALAC) under conditions that met standards of the Guide for the Care and Use of Laboratory Animals, as well as those set by the United States Department of Agriculture. The light cycle was 12:12, and animals were provided with enrichment through the use of novel toys, supplemental hay, and frequent handling by the care staff. Eight ounces of laboratory grade feed (Harlan Laboratories) was provided daily, and water was provided ad libitum.

5.1 Test Animal Study

Prior to the commencement of the drug absorption study, a test run was conducted on one anesthetized test subject (NZW rabbit) obtained through the Texas A&M University Laboratory Animal Resources and Research Facility (LARR) in order to ensure proper device setup and function, as well as to ascertain how the animal would

tolerate electrical stimulation. This study was beneficial to test system operation on a live subject, discern ideal electrode configuration and placement, and to find the best placement for the animal during the study.

The animal was anesthetized with a combination of ketamine, xylazine, and acepromazine (35 mg/kg ketamine, 5 mg/kg xylazine and 0.75 mg/kg acepromazine) administered intramuscularly (IM). The appropriate depth of anesthesia was confirmed prior to the commencement of the study by use of a toe pinch reflex. The animal was intubated with an endotracheal tube which was left open for non-assisted breathing and placed on its left side. Intubation was performed to keep the orally administered octreotide from being aspirated and/or dripping down the esophagus. Gauze was utilized to secure the endotracheal tube, and the animal's head was propped up with a small towel at an angle of approximately 15 degrees. The stainless steel wire electrode loop was placed around the tongue and attached to the output pin of the precision current source. Aluminum cardiac pacing wire was placed subcutaneously in the animal's right thigh and attached to the circuit ground.

The electrical system was then turned on, beginning at 0 volts direct current. We incrementally increased/decreased the input signal in tenths of a volt until we reached +/-8 mA across the test subject. During the early stages of this pilot experiment, it was discovered that the disparity in the thigh and oral electrode materials was causing a DC offset, and consequently the thigh electrode was replaced with the same stainless steel

as the oral electrode. Additionally, we tested alternating square wave tolerance at 20 Hertz (Hz), again beginning at 0 mA peak-to-peak and incrementally increasing by a tenth of a mA until twitching was observed. This occurred around 5 mA peak-to-peak current across the rabbit. From this initial test study we determined that the approximate impedance of the oral mucosa of the rabbit was 1.2 k Ω (measured with a multimeter), and that the target direct current stimulus to test subjects would be between +/-4 mA, while the target alternating current would be approximately 4 mA peak-to-peak.

Administration of octreotide acetate to the oral cavity of the animal was performed until we were able to deliver the drug from the syringe at a constant rate of 1 ml/minute.

Upon completion of the test study, the animal was euthanized in accordance with an approved Facility Use Protocol with an overdose of a barbiturate.

5.2 Octreotide Absorption Study Protocol

The industrial partner for this project, SEP Technologies, has performed preliminary unpublished experiments that show that electrical stimulation may act in two ways to increase octreotide diffusion across the mucous membrane: 1) via a net electrical field (DC current) across the mucous membrane to increase diffusion of a charged molecular drug entity across the membrane, and 2) via alternating current stimulation to open up

capillaries and pores, as well as increase local blood flow, and thus increase absorption into the blood stream.

We utilized twenty five SPF NZW rabbits from the same lot, of similar weights (and hence similar blood volumes), and of the same sex (females) obtained from Harlan Laboratories in order to effectively compare octreotide serum concentrations and limit variances between test subjects. Syringes of octreotide acetate were obtained from Sigma-Aldrich® and stored in the refrigerator at LARR. All octreotide was from lot AL11007 and expires on 1/2013.

Each rabbit was randomly assigned a number (R41-R65) in order to blind the personnel performing the serum octreotide concentration analysis, and experiments were performed in a randomly selected order. Five groups of five subjects were tested to determine feasibility of the SEP technology using a small, charged peptide that is relatively non-absorbable across the mucosa without stimulation. Each test group consisted of five test subjects, and included:

- a) Subcutaneous Control Group (Control) – to establish a benchmark or gold standard for octreotide absorption into the blood stream; each SubQ animal received a bolus injection of 1 ml of 50 mcg/ml octreotide for a total dosage of 50 mcg.

- b) Baseline Oral Absorption Control Group (Sham) – to establish a baseline blood concentration of octreotide absorption across the oral mucosa in the absence of electrical stimulation; serum octreotide concentrations of the stimulated groups will be compared against this group to establish statistical significance of electrical stimuli on sublingual octreotide absorption. Each animal in this group received an oral drip for the duration of stimulation at a rate of 0.1 ml/minute of 50 mcg/ml octreotide (total 3 mls over 30 minutes, 150 mcg total).
- c) Positive Direct Current (+DC) Stimulation Group – to test how sublingual octreotide absorption is enhanced by the application of 4 mA DC stimulus across the oral mucosa. Each animal in this group received an oral drip for the duration of stimulation at a rate of 0.1 ml/minute of 50 mcg/ml octreotide (total 3 mls over 30 minutes, 150 mcg total).
- d) Negative Direct Current (-DC) Stimulation Group – to test how absorption is enhanced by the application of a negative 4 mA DC stimulus across the oral mucosa. Each animal in this group received an oral drip for the duration of stimulation at a rate of 0.1 ml/minute of 50 mcg/ml octreotide (total 3 mls over 30 minutes, 150 mcg total).
- a) Alternating Current (AC) Stimulation Group – to test how absorption is enhanced by the application of a 20 Hz alternating current square wave 4 mA peak-to-peak stimulus to the oral mucosa. Each animal in this group received an

oral drip for the duration of stimulation at a rate of 0.1 ml/minute of 50 mcg/ml octreotide (total 3 mls over 30 minutes, 150 mcg total).

Each rabbit was injected with a combination of ketamine, xylazine, and acepromazine (35 mg/kg ketamine, 5 mg/kg xylazine, and 0.75 mg/kg acepromazine injected IM) to induce anesthesia ten minutes before the commencement of its respective study. It was determined that the experimental duration for each animal would be 30 minutes based on expected length of anesthesia following one dose (approximately 45 - 60 minutes). If animals showed signs of distress, depth of anesthesia was determined via a toe pinch reflex, and if needed re-dosed with a half-dose of anesthesia. Animals were terminated immediately upon completion of the experiment with an overdose of the same anesthetic utilized to induce anesthesia and disposed of in accordance with the TAMU approved AUP. Following euthanasia, tissues were provided to other investigators through the TAMU Tissue Sharing Program in order to assure the maximum possible use of the animals.

Subcutaneous Control Group

After anesthesia was administered and the appropriate depth confirmed via a toe pinch reflex, the animal was placed in left lateral recumbency on the operating table and a bolus injection of 1 ml of 50 mcg/ml octreotide acetate (total 50 mcg) was administered subcutaneously between the shoulder blades at time zero of the study.

At time zero, 5 minutes, 10 minutes, and 30 minutes 3 ml of blood was drawn with a needle and syringe from the auricular artery of the left ear for serum octreotide concentration analysis. Alternately, the right ear was used if the left ear artery became blocked or constricted. All blood samples were then placed in a serum separator tube and allowed to clot (Fig. 7), and they were stored in the refrigerator until processing later in the same day as the experiment was performed.



Figure 7: Serum Separator Tube Containing Blood Sample. Serum separator tube containing clotted raw samples for octreotide testing

Electrical Stimulation Groups (Positive DC, Negative DC, and AC stimuli)

After anesthesia was administered and confirmed utilizing the toe pinch reflex, the animal's right hip was shaved in preparation for the ground electrode placement. The animal was intubated to ensure that the oral drip stayed in the oral cavity and did not drip down the animal's esophagus or trachea. The animal was then placed on its left side on the operating table with its head propped up with a towel to ensure that the oral drip stayed in the oral cavity (Fig. 8). The oral electrode was placed in the oral cavity around the tongue, in contact with the sublingual mucosa. The hip electrode was inserted subcutaneously with a reverse cutting needle so that it penetrated the skin and then exited the skin approximately a half inch from the insertion point. With the function generator set to either direct current at zero volts or alternating 20 Hz square wave at zero volts peak-to-peak and turned in the "off" position, the oral electrode was connected to the output pin of the precision current source, and the thigh electrode was connected to ground utilizing alligator clips. The oral cavity was moistened slightly immediately prior to commencement of electrical stimulation to ensure similar impedance throughout the study (impedance is significantly increased when the mucosa is dry).



Figure 8: Animal Set Up. Animals were intubated and placed on their left side for the duration of the experiment with head propped on a towel to maximize amount of oral drip that stayed in contact with the mucosa

At time zero, the function generator was switched to the “on” position and increased/decreased to the target current (± 4 mA DC, 4 mA peak-to-peak AC), the octreotide acetate oral drip (50 mcg/ml) was commenced at a rate of 0.1 ml/minute for 30 minutes (total volume of 3 mls, total dosage of 150 mcg octreotide), and the time zero blood draw was performed (3 ml from the auricular artery in the left ear with a needle and syringe, placed in a serum separator tube and allowed to clot). Each animal was monitored carefully throughout the duration of the experiment to ensure that no muscle tetany or twitching occurred, and the voltage across the mucosa was monitored throughout the experiment via the oscilloscope for Rr calculations. Blood draws were

performed in the same manner as the time zero blood draw at 5 minutes, 10 minutes, and 30 minutes for octreotide serum concentration testing. At time=30 minutes, the oral drip ceased, and the function generator was switched to the “off” position to halt electrical stimulation. The oral electrode was then removed from the oral cavity, and the animal was euthanized with an overdose of a barbiturate as approved in the TAMU IACUC-approved AUP. Tissue was harvested post-mortem through the TAMU Tissue Share program (if there was a need). Termination was confirmed by absence of corneal reflex and cessation of heart beat and respiration for at least 5 minutes. Animals were disposed of in accordance with our TAMU IACUC-approved AUP.

Baseline Oral Absorption Control Group (Sham)

After anesthesia was administered and confirmed utilizing the toe pinch reflex, the animal’s right hip was shaved in preparation for the ground electrode placement. The animal was intubated to ensure that the oral drip stayed in the oral cavity and did not drop down the animal’s throat or into the lungs. The animal was then placed on its left side on the operating table with its head propped up with a towel to ensure that the oral drip stayed in the oral cavity. The oral electrode was placed in the oral cavity around the tongue, in contact with the sublingual mucosa. The hip electrode was inserted subcutaneously with a reverse cutting needle, and then exited the skin approximately one half inch from the insertion point. The electrodes were not attached to the precision current source in this group.

At time zero, the octreotide acetate oral drip was commenced at a rate of 0.1 ml/minute 50 mcg/ml for 30 minutes (total volume of 3 mls, total dosage of 150 mcg), and the time zero blood draw was performed (3 ml from the auricular artery in the left ear with a needle and syringe) and placed in a serum separator tube and allowed to clot. Blood draws were performed in the same manner as the time zero blood draw at 5 minutes, 10 minutes, and 30 minutes for octreotide serum concentration testing. At time=30 minutes, the oral drip ceased. The oral electrode was then removed from the oral cavity and the animal was euthanized with an overdose of a barbiturate as approved in the TAMU IACUC-approved AUP. Tissue was harvested post-mortem through the TAMU Tissue Share program (if there was a need). Termination was confirmed with absence of corneal reflex and cessation of heart beat and respiration for at least 5 minutes. Animals were disposed of in accordance with our TAMU IACUC-approved AUP.

Blood Sample Preparation for Octreotide Concentration Analysis

The clotted samples were stored in the refrigerator until centrifugation (Fig. 9). After spinning the sample serum was extracted and placed in 1 ml aliquots, each containing about 0.5 ml of serum. The serum samples were labeled by rabbit number, blood draw time (0, 15, or 30), date acquired, and PI name, then stored in the -20 degrees Fahrenheit no-frost freezer until delivery to the radioimmunoassay laboratory.

Experiment Design

To test the proposed mechanisms of increased octreotide acetate diffusion into systemic circulation, we used 5 different experimental groups, each consisting of 5 animals. The groups were: 1) subcutaneous injection control group, 2) positive DC stimulus across oral mucosa with octreotide drip in oral cavity, 3) negative DC stimulus with octreotide drip in oral cavity, 4) alternating square wave with octreotide drip in oral cavity, and 5) sham group with octreotide drip in oral cavity to determine the baseline absorption across the oral mucosa. The stimulation groups (2-4) were compared to group 5 with no stimulation (i.e, sham or baseline sublingual absorption group) to test our hypothesis that electrical stimulation will increase the absorption. A control group (injected with a 1 ml bolus of 50 mcg/ml octreotide at time zero) was also included to compare oral drip results with the current gold standard of octreotide administration. The animals were randomized into the 5 groups, and the laboratory performing the serum tests was blinded.



Figure 9: Centrifuge. Clotted samples were centrifuged, then serum to be tested for octreotide concentration was extracted and stored in the -20 degrees Fahrenheit freezer

6. ASSESSMENT OF ORAL LOW-CURRENT DC AND AC STIMULI ON SUBLINGUAL DIFFUSION OF OCTREOTIDE INTO THE BLOOD STREAM OF RABBITS

Following the completion of the animal studies the frozen aliquots of serum samples were delivered to the Texas A&M University Veterinary Teaching Hospital Gastrointestinal Laboratory for radioimmunoassay (RIA) analysis to determine serum concentrations of octreotide. These data were then processed and utilized to determine the efficacy of DC and AC stimuli on sublingual absorption of octreotide. Upon completion of the concentration analysis, statistical significance was determined between absorption rates of each stimulation group and the Sham group using a Welch's t-test (a test for statistically significant difference in means of two groups with unequal variance). The three hypotheses tested were:

- 1) Positive direct current electrical stimulation will increase absorption of octreotide so that the mean serum octreotide concentration of the +DC group will be greater than that of the sham group, or +DC group > sham, and similarly:
- 2) -DC group > sham and
- 3) AC group > sham

Given that the hypotheses are only one-sided (i.e., only the “greater than” side is considered), a one-sided Welch’s t-test was used and a p-value of less than 0.05 was considered to be significant. If electrical stimulation was indeed successful in improving the systemic concentration of octreotide, each electrical stimulation group was compared to determine which stimulation scenario rendered the most successful results.

This pilot study was designed solely to discern whether or not electrical stimulation increased sublingual diffusion of octreotide into the circulation, and was not designed to establish therapeutic significance of sublingual diffusion. However, serum octreotide concentrations for sublingual diffusion groups (+DC Stim, -DC Stim, AC Stim, and Baseline Oral Absorption Groups) were compared to serum octreotide concentrations in the Subcutaneous Injection Group and to typical known therapeutic plasma concentrations in humans to determine how sublingual diffusion compared to therapeutically significant serum concentrations (the current “gold standard” for octreotide administration).

6.1 Radioimmunoassay Analysis

Radioimmunoassay analysis was performed by Stephen Lagutchik, a technician in the Gastrointestinal Lab at the Veterinary Medicine Teaching Hospital at Texas A&M University. First, the samples were purified, and the octreotide was extracted using S-5000 extraction Kits purchased from Peninsula Laboratories. Once the octreotide

(primary antibody) was extracted, an RIA buffer, antiserum, a radioactive tracer, and a secondary antibody were added utilizing a rabbit octreotide RIA kit from Bachem (S-2217 Octreotide RIA kit). This kit has a typical sensitivity of 0.17 ng/ml and a range of 0.010 – 1.28 ng/ml. The known concentration of tracer competes with the unknown concentration of antigen (octreotide) in the sample for binding sites on the antiserum. Immunocomplexes were precipitated by adding normal serum and secondary antibodies followed by centrifugation. The unbound reagents were decanted, leaving the radioactive pellet behind. The pellet was counted on the gammacounter, which measures the radioactivity of the pellet in counts per minute (cpm). The more antigen (octreotide) that binds to the antiserum, the less the tracer is bound, so a higher concentration of antigen (octreotide) correlates to a lower cpm. Using the cpm results for each tube from the gammacounter, the octreotide concentrations for each rabbit at each time point were calculated for each sublingual group.

6.2 Results

Sublingual Diffusion Serum Octreotide Concentration Analysis

Octreotide serum concentration tables were generated containing rabbit number, the date the experiment was performed, voltage input into the circuit (V_{in}), the voltage recorded across the animal during the experiments utilizing the oscilloscope (V_r ; Figs. 10 and 11), the known current across the animal (I_r ; I_r (mA) = V_{in} (v)), the calculated resistance value of each animal (R_r ; $R_r = V_r/I_r$), and serum concentrations

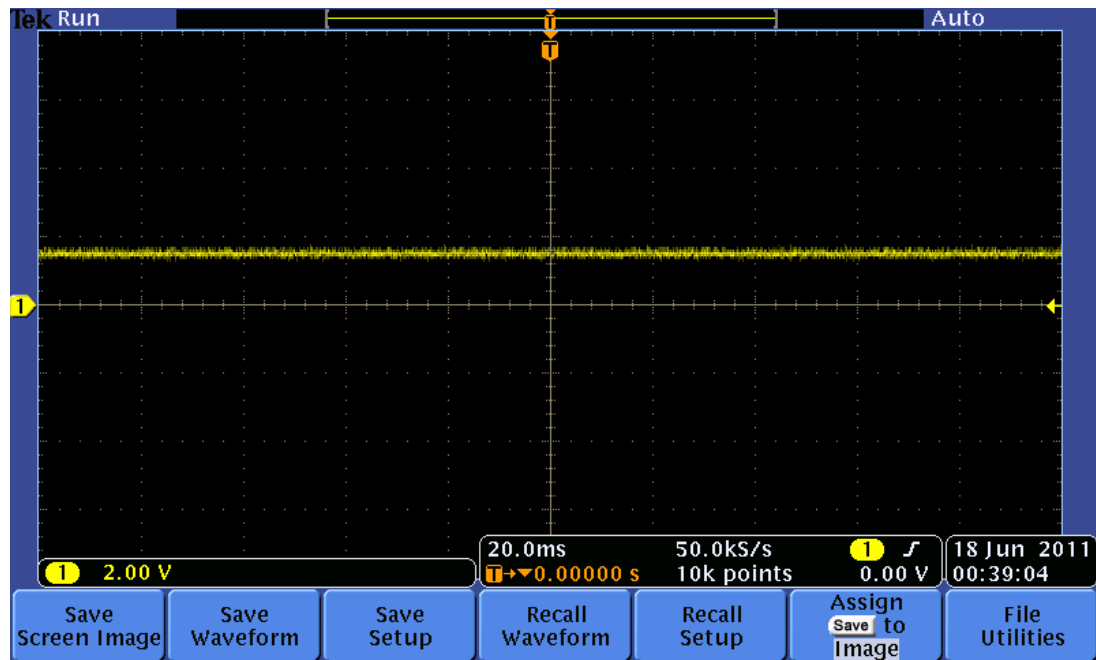


Figure 10: +DC Vr Oscilloscope Image. +DC voltage measured across R46

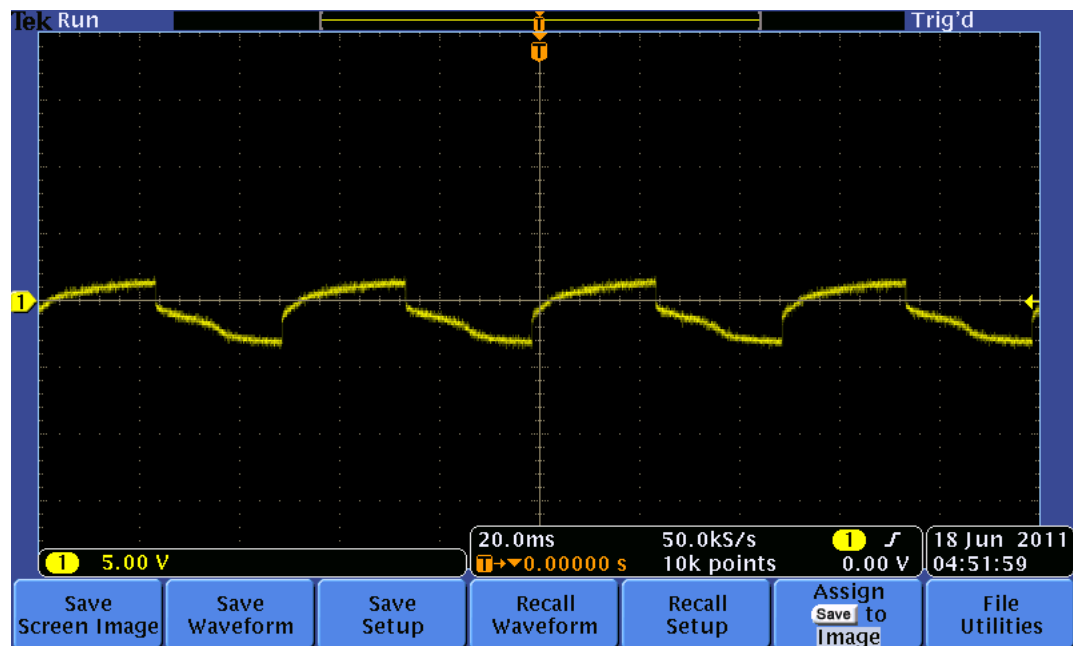


Figure 11: AC Vr Oscilloscope Image. AC voltage measured across R50. Signal is not a perfect square wave due to capacitance properties of the rabbit not accounted for in circuit design.

for each sublingual diffusion group (Tables 1-4). Octreotide serum concentration data over time are displayed as a line plot and contains concentration values for each rabbit at each time point (blood draw), as well as the average concentration for that group (Figs. 12 - 15). For one animal in each stimulation group, the voltage across the animal was observed multiple times and recorded for R_r calculations. For the Positive DC Stimulation Group, the I_r for all rabbits was 4 mA and the average R_r was 1.8 k Ω . For the Negative DC Stimulation Group, the I_r for all rabbits was -4 mA and the average I_r was 1.7 k Ω . For the AC Stimulation Group, the average I_r was 2.3 mA peak-to-peak and the average I_r was 1.4 k Ω . Note that the target current for AC became 2 mA peak-to-peak when R50 displayed twitching at both 4 mA peak-to-peak and 3 mA peak-to-peak.

A single-sided Welch's t-test was performed to determine statistical significance of serum octreotide concentration at $t=30$ for each stimulated group (compared to serum octreotide concentrations at $t=30$ in the Baseline Oral Absorption group). A p value of less than 0.05 was our indicator for statistical significance. Each stimulated group was compared to the Oral Baseline Absorption Group to determine how/if stimulation increased serum octreotide concentration, and p values were calculated for each to determine statistical significance of the effects of electrical stimulus on serum octreotide concentrations.

The maximum octreotide serum concentration for the Baseline Oral Absorption Group at 30 minutes was R48 with a concentration of 0.17 ng/ml, and the mean at 30 minutes was 0.074 ng/ml. We found that after 30 minutes of stimulation, +DC stimulation produced an average serum octreotide concentration that was nine times greater than the Baseline Oral Absorption group (max was in R51 with a concentration of 1.33 ng/ml, and mean is 0.677 ng/ml.), and was found to be statistically significant with a p value of 0.023. The Negative DC Stimulation group had an average serum octreotide concentration that was seven times greater than the Baseline Oral Absorption group after 30 minutes of exposure to oral octreotide (max was in R49 with a concentration of 1.575 ng/ml, and mean was 0.535 ng/ml.), but could not be confirmed as statistically significant with a p value of 0.08. The AC Stimulation group had an average octreotide serum concentration at t=30 minutes that was 3 times greater than the average octreotide serum concentration of the Baseline Oral Absorption group at t=30 minutes (max was in R61 with a concentration of 0.65 ng/ml, and mean was 0.253 ng/ml), but was not statistically significant with a p value of 0.09. Average octreotide concentrations for each sublingual diffusion group (+DC Stim, -DC Stim, AC Stim, and Baseline Absorption) are displayed as a line plot for more clear comparison between sublingual diffusion groups (Fig. 16).

TABLE 1: Baseline Oral Absorption Group Serum Octreotide Concentration Data (ng/ml)

Rabbit #	Date	Weight (kg)	Vin (v)	Vr (v)	Ir (mA)	Avg. Rr(k Ω)	0 mins	5 mins	10 mins	30 mins
44	16-Jun	3.13	0	-	-	-	0.040	0.040	0.000	0.025
48	17-Jun	3.08	0	-	-	-	0.045	0.050	0.140	0.170
52	17-Jun	3.22	0	-	-	-	0.060	0.060	0.050	0.065
56	20-Jun	3.36	0	-	-	-	0.040	0.045	0.030	0.030
64	21-Jun	3.04	0	-	-	-	0.060	0.070	0.065	0.080
Average:		3.17	0	-	-	-	0.049	0.053	0.057	0.074
Standard Deviation:		0.11	-	-	-	-	0.009	0.011	0.047	0.052

Rabbit number, experiment date, animal weights, input voltage (zero for all since this group received no stimulation), and serum octreotide concentrations. This group was used as a baseline to determine statistical significance of serum octreotide concentrations in the stimulated groups.

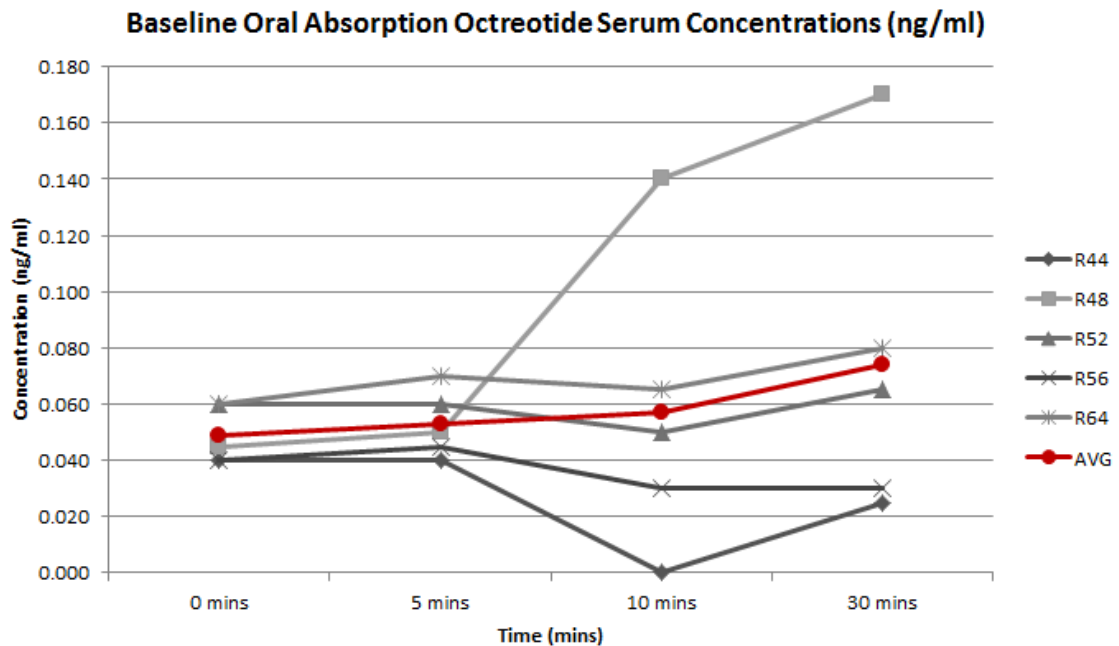


Figure 12: Baseline Oral Absorption Group Octreotide Serum Concentrations. Baseline Oral Absorption group serum octreotide concentrations for each rabbit, as well as the average for the group in ng/ml. The max serum concentration at 30 mins is R48 with a concentration of 0.17 ng/ml, and the mean at 30 mins is 0.074 ng/ml. This group was used as a baseline to determine statistical significance of serum octreotide concentrations in the stimulated groups.

TABLE 2: Positive DC Stimulus Group Serum Octreotide Concentration Data (ng/ml)

Rabbit #	Date	Weight (kg)	Vin (v)	Vr (v)	Ir (mA)	Avg. Rr(k Ω)	0 mins	5 mins	10 mins	30 mins
42	16-Jun	2.99	4.0	6.0	4.0	1.5	0.040	0.045	0.020	0.335
43	16-Jun	3.18	4.0	7.0	4.0	1.8	0.030	0.030	0.045	0.130
51	17-Jun	2.90	4.0	7.5	4.0	1.9	0.035	0.150	0.440	1.330
57	20-Jun	3.08	4.0	7.5	4.0	1.9	0.055	0.175	0.305	0.900
60	21-Jun	3.13	4.0	7.0	4.0	1.8	0.025	0.105	0.165	0.690
Average:		3.06	4.0	7.0	4.0	1.8	0.037	0.101	0.195	0.677
Standard Deviation:		0.10	0.0	0.5	0.0	0.1	0.010	0.057	0.159	0.422

p Value at t=30 mins: 0.023

Rabbit number, experiment date, animal weights, input voltage, measured voltage across the rabbit, current across the rabbit, calculated resistance of the rabbit, and serum octreotide concentration for each rabbit at each blood draw time point. P value for octreotide serum concentration at 30 minutes (as compared to Baseline serum concentration at 30 mins) is 0.023, which is statistically significant.

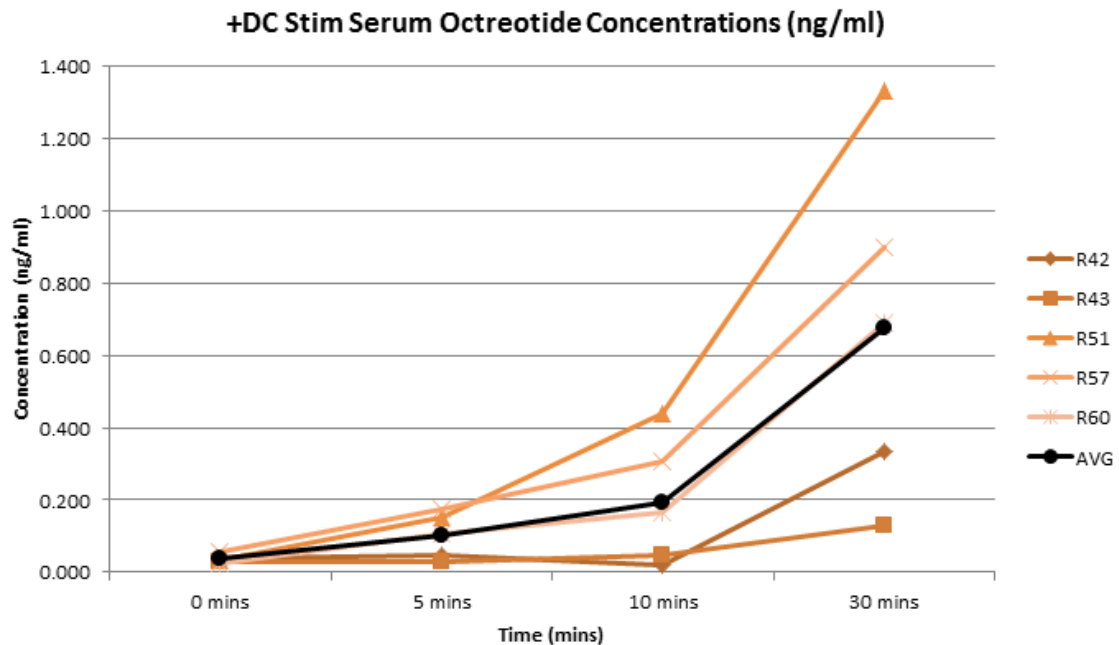


Figure 13: +DC Stim Serum Octreotide Concentrations. Positive DC Stimulation Group serum octreotide concentrations for each rabbit, as well as the average for the group in ng/ml from zero to thirty minutes. The max at 30 mins is R51 with a concentration of 1.33 ng/ml, and the mean at 30 mins is 0.677 ng/ml. When compared to Baseline concentrations at 30 minutes, P value for octreotide serum concentration at 30 minutes is 0.023, which is statistically significant.

TABLE 3: Negative DC Stimulus Group Serum Octreotide Concentration Data (ng/ml)

Rabbit #	Date	Weight (kg)	Vin (v)	Vr (v)	Ir (mA)	Avg. Rr(k Ω)	0 mins	5 mins	10 mins	30 mins
47	17-Jun	2.95	-4.0	-7.0	-4.0	1.8	0.060	0.080	0.050	0.095
49	17-Jun	3.18	-4.0	-6.0	-4.0	1.5	0.040	0.115	0.555	1.575
54	20-Jun	3.27	-4.0	-6.0	-4.0	1.5	0.040	0.050	0.045	0.045
55	20-Jun	3.18	-4.0	-7.0	-4.0	1.8	0.045	0.090	0.260	0.510
63	21-Jun	2.99	-4.0	-7.0	-4.0	1.8	0.055	0.060	0.120	0.450
Average:		3.11	-4.0	-6.6	-4.0	1.7	0.048	0.079	0.206	0.535
Standard Deviation:		0.12	0.0	0.5	0.0	0.1	0.008	0.023	0.191	0.552

p Value at t=30 mins: 0.085

Rabbit number, experiment date, animal weights, input voltage, measured voltage across the rabbit, current across the rabbit, calculated resistance of the rabbit, and serum octreotide concentration for each rabbit at each blood draw time point. When compared to Baseline concentrations at 30 minutes, P value for octreotide serum concentration at 30 minutes is 0.085, which is not statistically significant.

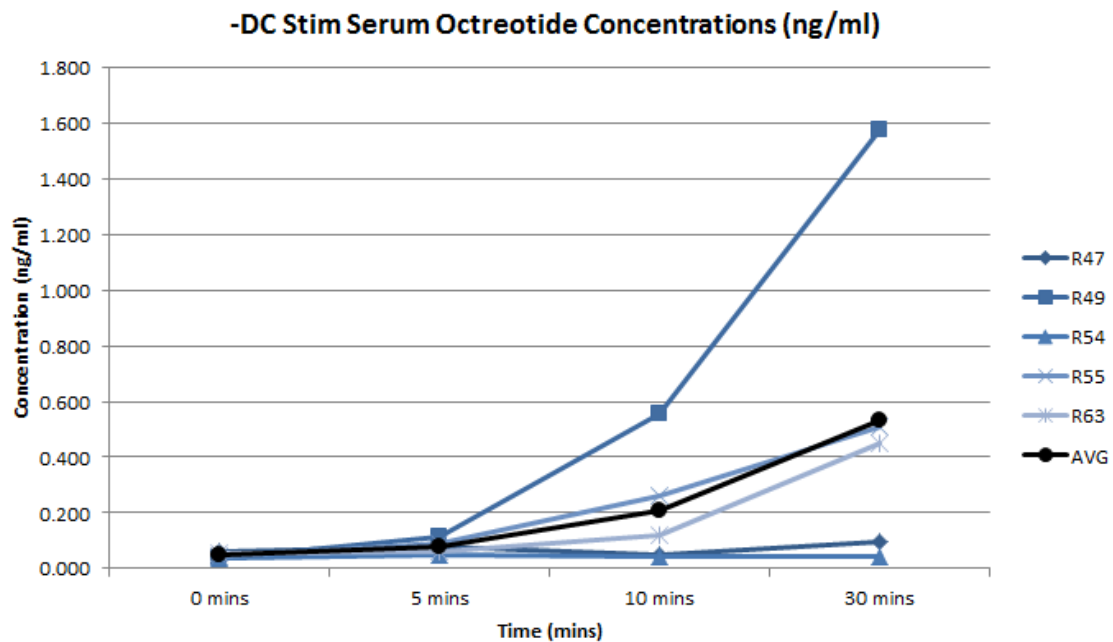


Figure 14: -DC Stim Serum Octreotide Concentrations. Negative DC Stimulation Group serum octreotide concentrations for each rabbit, as well as the average for the group in ng/ml from zero to thirty minutes. The max at 30 mins is R49 with a concentration of 1.575 ng/ml, and the mean at 30 mins is 0.535 ng/ml. When compared to Baseline concentrations at 30 minutes, P value for octreotide serum concentration at 30 minutes is 0.085, which is not statistically significant.

TABLE 4: AC Stimulus Group Serum Octreotide Concentration Data (ng/ml)

Rabbit #	Date	Weight (kg)	Vin (v)	Vr (v)	Ir (mA)	Avg. Rr(k Ω)	0 mins	5 mins	10 mins	30 mins
46	17-Jun	2.81	4.0	-	4	-	0.040	0.065	0.055	0.050
50	17-Jun	3.04	2.0	4.5	2.0	2.3	0.090	0.090	0.080	0.125
58	20-Jun	3.08	2.0	7.0	2.0	3.5	0.055	0.070	0.045	0.335
61	21-Jun	3.27	1.5	5.0	1.5	3.3	0.035	0.045	0.090	0.650
65	21-Jun	2.99	2.2	5.0	2.2	2.3	0.085	0.070	0.085	0.105
Average:		3.04	2.3	5.4	2.3	2.8	0.061	0.068	0.071	0.253
Standard Deviation:		0.15	0.9	1.0	0.9	0.6	0.023	0.014	0.018	0.221
p Value at t=30 mins:										0.091

Rabbit number, experiment date, animal weights, input voltage, measured voltage across the rabbit, calculated current across the rabbit, and serum octreotide concentration for each rabbit at each blood draw time point. When compared to Baseline concentrations at 30 minutes, P value for octreotide serum concentration at 30 minutes is 0.091, which is not statistically significant.

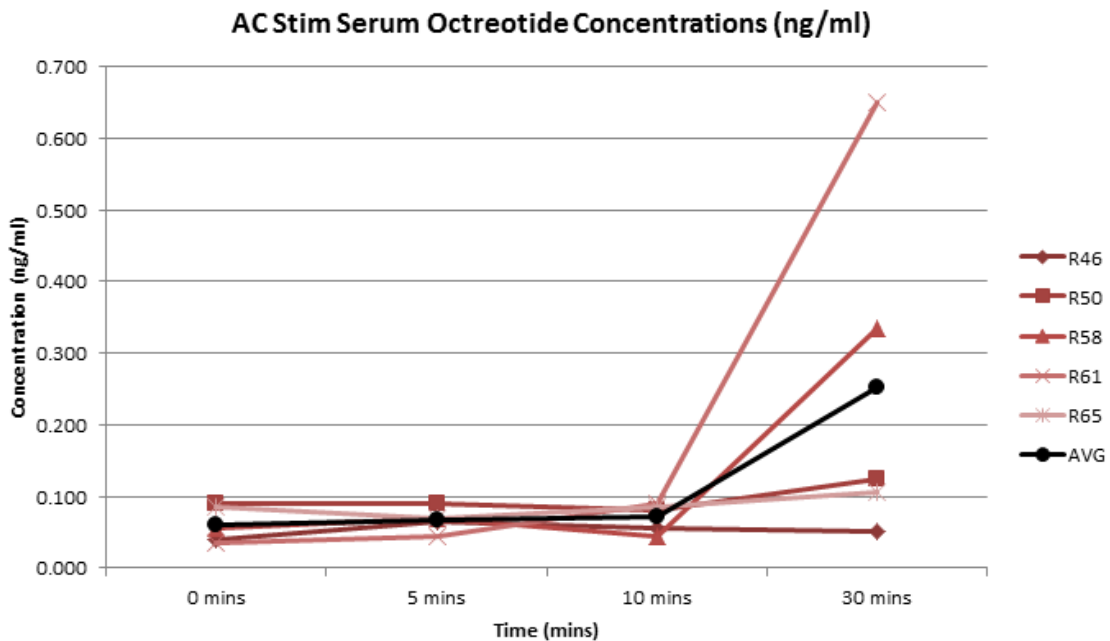


Figure 15: AC Stim Serum Octreotide Concentrations. AC Stimulation Group serum octreotide concentrations for each rabbit, as well as the average for the group in ng/ml from zero to thirty minutes. The max at 30 mins is R61 with a concentration of 0.65 ng/ml, and the mean at 30 mins is 0.253 ng/ml. When compared to Baseline concentrations at 30 minutes, P value for octreotide serum concentration at 30 minutes is 0.091, which is not statistically significant.

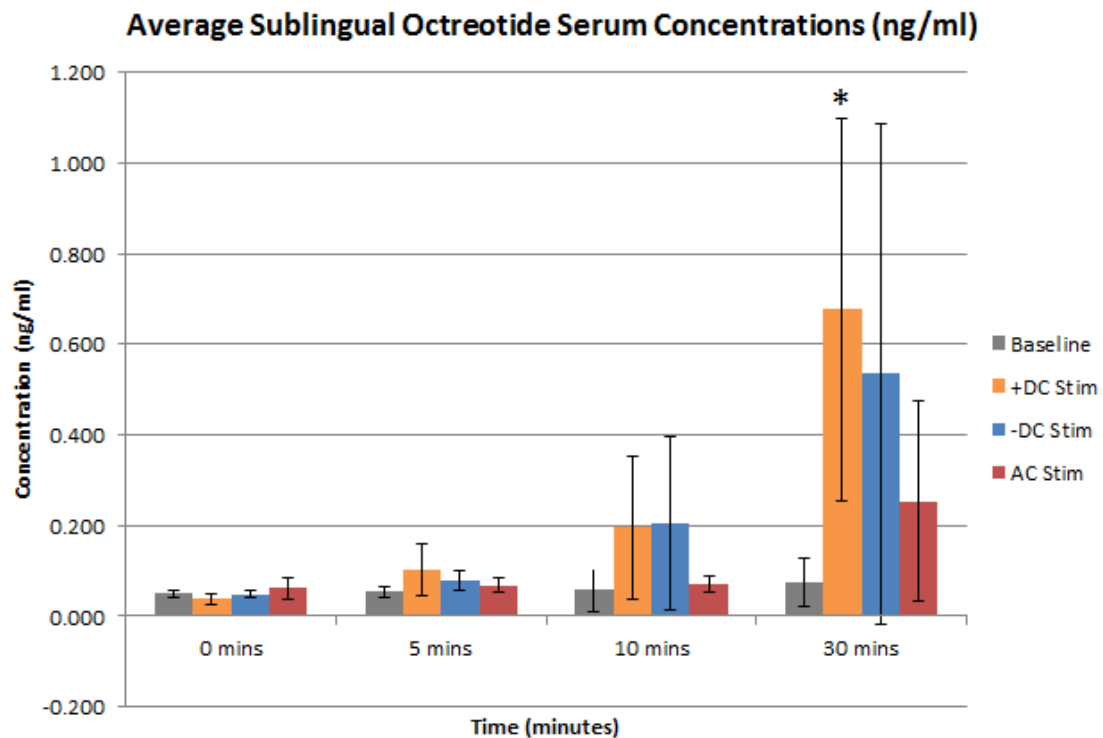


Figure 16: Average Sublingual Octreotide Serum Concentrations. Average serum octreotide concentrations for each sublingual diffusion group with standard deviation. All three stimulated groups exhibit higher serum octreotide concentrations than the Baseline Oral Absorption group (sublingual diffusion in the absence of electrical stimulation) at 30 mins. The +DC Stim Group exhibited the highest serum octreotide concentrations (nine times greater than the Baseline Group at 30 mins), the -DC Stim group exhibited serum octreotide concentrations greater than the AC Stim Group but less than the +DC Stim Group (seven times greater than the Baseline Group at 30 mins), and the AC Stim Group exhibited the lowest serum octreotide concentrations of the stimulated groups (three times greater than the Baseline Group at 30 mins). * indicates statistical significance.

Sublingual Diffusion Octreotide Absorption Rate Analysis

Our working hypothesis is that electrical stimulation will increase serum concentration of octreotide via an increased rate of absorption. To explicitly test this mechanism of action, the time rate of change of octreotide concentration (absorption rate) was also calculated for each group to display effect of stimulation on sublingual octreotide diffusion. This was done by taking the change in concentration (concentration at t_2 – concentration at t_1) divided by the change in time ($t_2 - t_1$), to obtain the average serum concentration change per minute between each blood draw over the experimental duration. This was calculated for each animal at each Δ time point: between $t=0$ and $t=5$ mins (denoted as $d[1]/dt$); between $t=5$ mins and $t=10$ mins (denoted as $d[2]/dt$); and between $t=10$ mins and $t=30$ (denoted as $d[3]/dt$). These results were then displayed in a table and a single-sided Welch's t-test was performed on each stimulated group to determine statistical significance of electrical stimulation on octreotide absorption rate as compared to sublingual diffusion in the absence of electrical stimulation (Tables 5-8). The rate of serum concentration change was also displayed as bar graphs at each Δ time to visualize the rate of serum octreotide concentration change for each rabbit at each Δ time point (Fig.s 17 - 20). To compare the effects of each electrical stimulation scenario on the rate change of sublingual octreotide diffusion, the average rate concentration change for each sublingual diffusion group is displayed as well (Fig. 21).

In the Baseline Oral Absorption Group, the average absorption rate at all Δ time points was 0.01 ng/ml/min, with the highest absorption rate occurring in R48 at Δ time point2 (0.018 ng/ml/min)

The average octreotide absorption rate of the Positive DC Stimulation group for Δ time point1 (0.013 ng/ml/min) was 16 times greater than the rate of Baseline Oral Absorption Group at the same Δ time point; for Δ time point2, the +DC average absorption rate was 24 times greater than the Baseline group (0.019 ng/ml/min); and at Δ time point3, the +DC average absorption rate was 28 times greater than the octreotide absorption rate of the Baseline Oral Absorption Group in the same time frame (0.024 ng/ml/min). The highest absorption rate was seen at Δ time point2 in R51 (0.058 ng/ml/min). When all concentration rate changes for each rabbit over each Δ time point were compared with all rate changes in the Baseline Oral Absorption group, we found that +DC absorption rates were statistically significant, with a p value of 0.0008.

The average octreotide absorption rate of the Negative DC Stimulation group for Δ time point1 (0.006 ng/ml/min) was 8 times greater than the rate of the Baseline group at the same Δ time point; at Δ time point 2, the -DC group's average absorption rate (0.025 ng/ml/min) was 32 times greater than the Baseline group's average rate change at the same Δ time point; and the -DC Stim group's rate of concentration change at Δ time point3 (0.016 ng/ml/min) was 19 times greater than the octreotide absorption rate of the Baseline Oral Absorption Group in the same time frame. The highest absorption rate

was seen at Δ time point2 in R49 (0.088 ng/ml/min). When all concentration rate changes for each rabbit over each Δ time point were compared with all rate changes in the Baseline Oral Absorption group, we found that the -DC Stim Group absorption rates were statistically significant, with a p value of 0.032.

The average octreotide absorption rate of the AC Stimulation group at Δ time point1 (0.001 ng/ml/min) was 2 times greater than the rate of concentration change of the Oral Baseline Absorption group at the same Δ time point; at Δ time point2, the AC Stim group's average absorption rate (0.001 ng/ml/min) was almost equal to the rate of concentration change of the Baseline group at the same Δ time point; and the AC Stim group's average absorption rate at Δ time point3 (0.009 ng/ml/min) was ten times greater than the octreotide absorption rate of the Baseline Oral Absorption Group at the same Δ time. The highest absorption rate was seen at Δ time point 3 in R61 (0.028 ng/ml/min). When all concentration rate changes for each rabbit over each Δ time point were compared with all rate changes in the Baseline Oral Absorption group, we found that the AC Stim Group absorption rates were not statistically significant, with a p value 0.135.

TABLE 5: Baseline Oral Absorption Group Octreotide Absorption Rates (ng/ml/min)

Rabbit #	Date	Weight (kg)	Vin (v)	Vr (v)	Ir (mA)	Avg. Rr(k Ω)	d[1]/dt	d[2]/dt	d[3]/dt
44	16-Jun	3.13	0	-	-	-	0.000	-0.008	0.001
48	17-Jun	3.08	0	-	-	-	0.001	0.018	0.002
52	17-Jun	3.22	0	-	-	-	0.000	-0.002	0.001
56	20-Jun	3.36	0	-	-	-	0.001	-0.003	0.000
64	21-Jun	3.04	0	-	-	-	0.002	-0.001	0.001
Average:		3.17	0	-	-	-	0.001	0.001	0.001
Standard Deviation:		0.11	-	-	-	-	0.001	0.009	0.001

Rabbit number, experiment date, animal weights, input voltage (zero for all since this group received no stimulation), and calculated rate of serum octreotide concentration change. This group was used as a baseline to determine statistical significance of rate of serum octreotide concentration change in the stimulated groups.

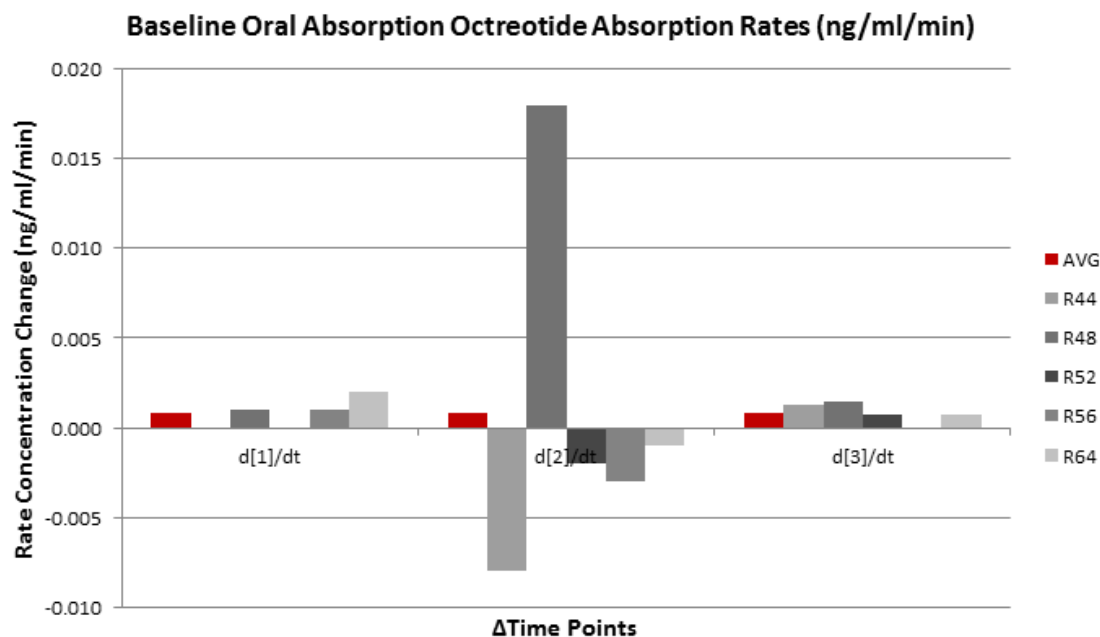


Figure 17: Baseline Oral Absorption Octreotide Absorption Rates. Baseline Oral Absorption Group calculated rate of serum octreotide concentration change for each rabbit, as well as the average for the group in ng/ml/min for Δ time points 1, 2, and 3. The average at all Δ time points is 0.01 ng/ml/min, with the highest absorption rate occurring in R48 at Δ time point2 (0.018 ng/ml/min). This group was used as a baseline to determine statistical significance of rate of serum octreotide concentration change in the stimulated groups.

TABLE 6: Positive DC Stimulation Group Octreotide Absorption Rates (ng/ml/min)

Rabbit #	Date	Weight (kg)	Vin (v)	Vr (v)	Ir (mA)	Avg. Rr(k Ω)	d[1]/dt	d[2]/dt	d[3]/dt
42	16-Jun	2.99	4.0	6.0	4.0	1.5	0.001	-0.005	0.016
43	16-Jun	3.18	4.0	7.0	4.0	1.8	0.000	0.003	0.004
51	17-Jun	2.90	4.0	7.5	4.0	1.9	0.023	0.058	0.045
57	20-Jun	3.08	4.0	7.5	4.0	1.9	0.024	0.026	0.030
60	21-Jun	3.13	4.0	7.0	4.0	1.8	0.016	0.012	0.026
Average:		3.06	4.0	7.0	4.0	1.8	0.013	0.019	0.024
Standard Deviation:		0.10	0.0	0.5	0.0	0.1	0.010	0.022	0.014

p Value for entire array: 0.0008

Rabbit number, experiment date, animal weights, input voltages, measured voltage across the rabbit, current across the rabbit, calculated rabbit resistance, and calculated rate changes in serum octreotide concentration. P value is 0.0008 over the entire array of calculated rate change in serum octreotide concentration values (as compared to the array of calculated rate change in octreotide concentration values in the Baseline Absorption Group), which is statistically significant.

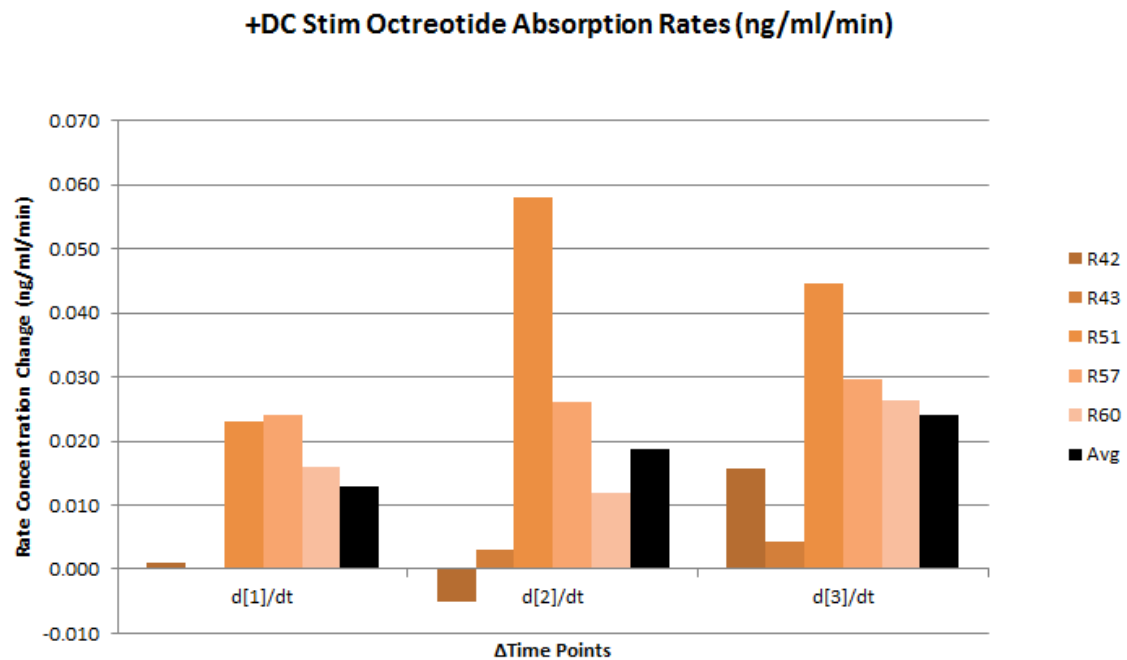


Figure 18: +DC Stim Octreotide Absorption Rates. Positive DC Stimulation Group calculated rate of serum octreotide concentration change for each rabbit, as well as the average for the group in ng/ml/min for Δ time points 1, 2, and 3. Average rate change at each Δ time point is 0.013 ng/ml/min, 0.019 ng/ml/min, and 0.024 ng/ml/min respectively. Highest absorption rate was seen at Δ time point 2 in R51 (0.058 ng/ml/min). P value for rate change of octreotide serum concentration over the entire array of concentration rate changes is 0.0008 (as compared to the array of calculated rate change in octreotide concentration values in the Baseline Absorption Group), which is statistically significant .

TABLE 7: Negative DC Stimulation Group Octreotide Absorption Rates (ng/ml/min)

Rabbit #	Date	Weight (kg)	Vin (v)	Vr (v)	Ir (mA)	Avg. Rr(k Ω)	d[1]/dt	d[2]/dt	d[3]/dt
47	17-Jun	2.95	-4.0	-7.0	-4.0	1.8	0.004	-0.006	0.002
49	17-Jun	3.18	-4.0	-6.0	-4.0	1.5	0.015	0.088	0.051
54	20-Jun	3.27	-4.0	-6.0	-4.0	1.5	0.002	-0.001	0.000
55	20-Jun	3.18	-4.0	-7.0	-4.0	1.8	0.009	0.034	0.013
63	21-Jun	2.99	-4.0	-7.0	-4.0	1.8	0.001	0.012	0.017
Average:		3.11	-4.0	-6.6	-4.0	1.7	0.006	0.025	0.016
Standard Deviation:		0.12	0.0	0.5	0.0	0.1	0.005	0.034	0.018

p Value for entire array: 0.032

Rabbit number, experiment date, animal weights, input voltages, measured voltage across the rabbit, current across the rabbit, calculated rabbit resistance, and calculated rate changes in serum octreotide concentration. P value is 0.032 over the entire array of calculated rate change in serum octreotide concentration values (as compared to the array of calculated rate change in serum octreotide concentration values in the Baseline Absorption Group), which is statistically significant.

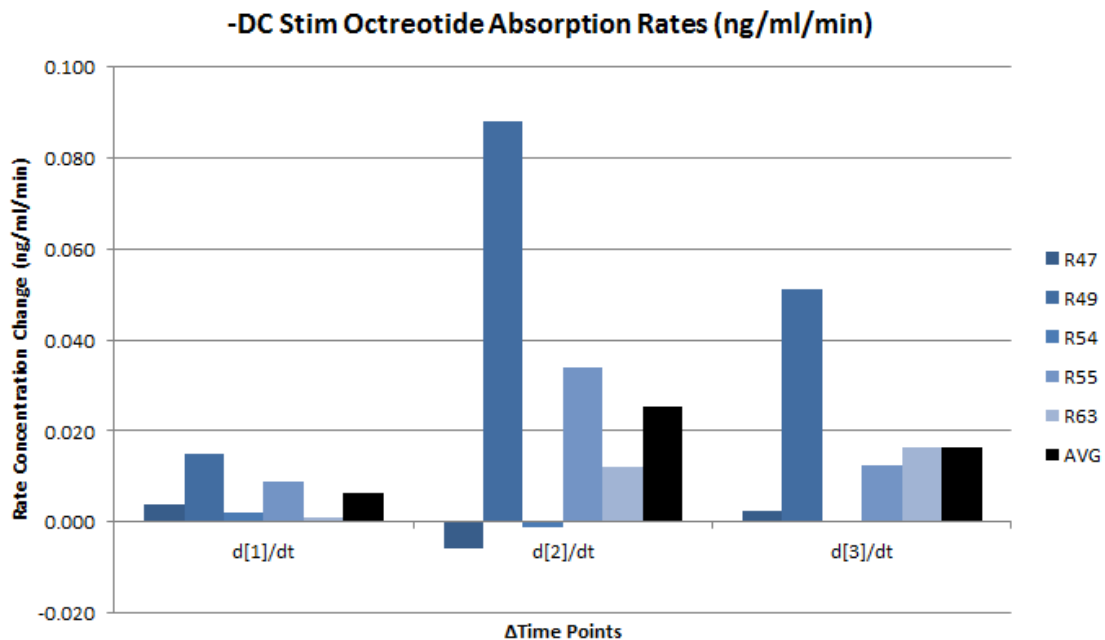


Figure 19: -DC Stim Octreotide Absorption Rates. Negative DC Stimulation Group calculated rate of serum octreotide concentration change for each rabbit, as well as the average for the group in ng/ml/min for Δ time points 1, 2, and 3. Average rate change at each Δ time point is 0.006 ng/ml/min, 0.025 ng/ml/min, and 0.016 ng/ml/min respectively. Highest absorption rate was seen at Δ time point 2 in R49 (0.088 ng/ml/min). P value for rate change of octreotide serum concentration over the entire array of concentration rate changes is 0.032 (as compared to the array of calculated rate change in octreotide concentration values in the Baseline Absorption Group), which is statistically significant.

TABLE 8: AC Stimulation Group Octreotide Absorption Rates (ng/ml/min)

Rabbit #	Date	Weight (kg)	Vin (v)	Vr (v)	Ir (mA)	Avg. Rr(k Ω)	d[1]/dt	d[2]/dt	d[3]/dt
46	17-Jun	2.81	4.0	-	4.0	-	0.005	-0.002	0.000
50	17-Jun	3.04	2.0	4.5	2.0	2.3	0.000	-0.002	0.002
58	20-Jun	3.08	2.0	7.0	2.0	3.5	0.003	-0.005	0.015
61	21-Jun	3.27	1.5	5.0	1.5	3.3	0.002	0.009	0.028
65	21-Jun	2.99	2.2	5.0	2.2	2.3	-0.003	0.003	0.001
Average:		3.04	2.3	5.4	2.3	2.8	0.001	0.001	0.009
Standard Deviation:		0.15	0.9	1.0	0.9	0.6	0.003	0.005	0.011

p Value for entire array: 0.135

Rabbit number, experiment date, animal weights, input voltages, measured voltage across the rabbit, current across the rabbit, calculated rabbit resistance, and calculated rate changes in serum octreotide concentration. P value is 0.135 over the entire array of calculated rate change in serum octreotide concentration values (as compared to the array of calculated rate change in serum octreotide concentration values in the Baseline Absorption Group), which is not statistically significant.

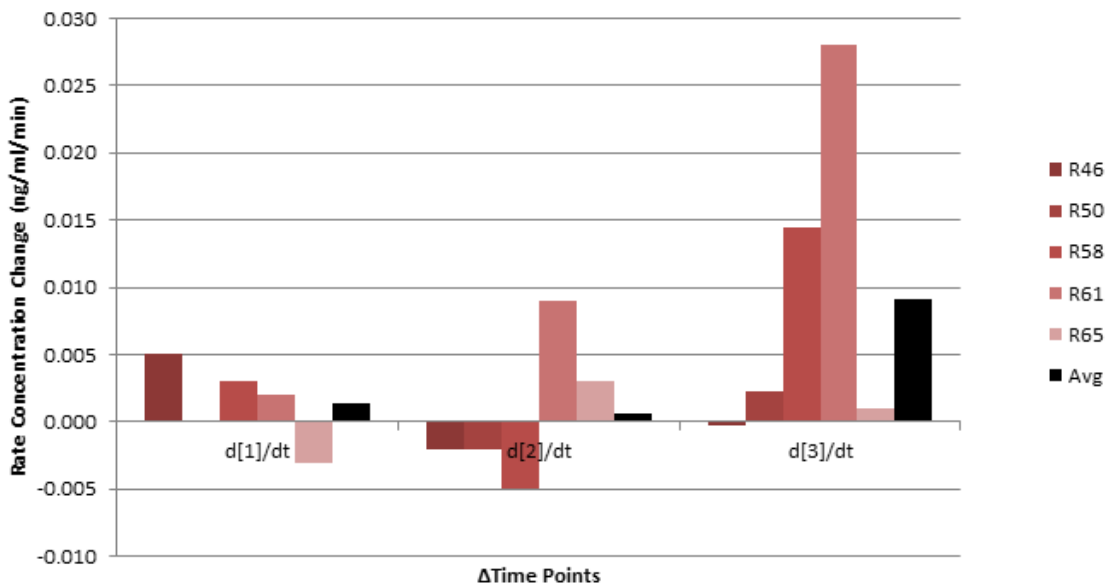
AC Stim Octreotide Absorption Rates (ng/ml/min)

Figure 20: AC Stim Octreotide Absorption Rates. AC Stimulation Group calculated rate of serum octreotide concentration change for each rabbit, as well as the average for the group in ng/ml/min for Δ time points 1, 2, and 3. Average rate change at each Δ time point is 0.001 ng/ml/min, 0.001 ng/ml/min, and 0.009 ng/ml/min respectively. Highest absorption rate was seen at Δ time point 3 in R61 (0.028 ng/ml/min). P value for rate change of serum octreotide concentration over the entire array of concentration rate changes is 0.135 (as compared to the array of calculated rate change in octreotide concentration values in the Baseline Absorption Group), which is not statistically significant.

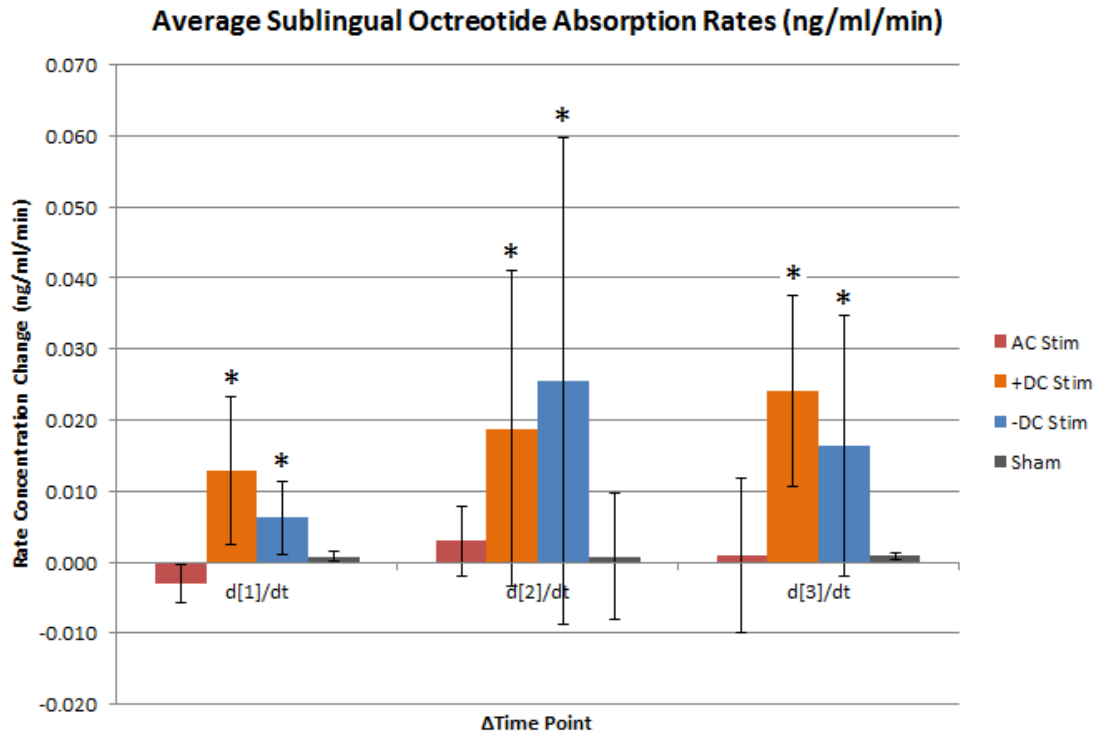


Figure 21: Average Sublingual Octreotide Absorption Rates. Average calculated rate of serum octreotide concentration change for sublingual group in ng/ml/min for Δ time points 1, 2, and 3. At Δ time point1, +DC absorption rate is 16x greater than Baseline; -DC absorption rate is 8x more than Baseline; and AC absorption rate is 2x greater than Baseline. At Δ time point2, +DC absorption rate is 24x Baseline; -DC absorption rate is 32x greater than Baseline; and AC absorption rate is equal to Baseline. At Δ time point3, +DC absorption rate is 28x greater than Baseline; -DC absorption rate is 19x greater than Baseline; and AC absorption rate is 11x greater than Baseline. When all rate concentration changes at each Δ time point for each rabbit were compared to Baseline, +DC was statistically significant, $p=0.0008$; -DC was statistically significant, $p=0.032$; AC was not statistically significant, $p=0.135$. * indicates statistical significance.

Subcutaneous Serum Octreotide Concentration Analysis

The intended dosage of octreotide for the subcutaneous group was calculated by taking the lower level of therapeutic dosage and serum concentration in humans (100 mcg dose, 5.2 ng/ml serum concentration) and dividing by twenty-two. The assumptions used in these calculations were based on the fact that rabbit blood volume (BVr) in milliliters is approximately 7% of its body weight (BWr) in grams (this parameter is a widely accepted estimate of rabbit blood volume; average in our SubQ animals was 208 ml). Additionally, BVr is approximately twenty times less than that of a human (BVh; human blood volume is between 4700 – 5000 ml). The equations used were:

$$BVr = 0.07 * BWr$$

$$\text{Blood volume ratio} = \frac{BVh}{BVr} = \frac{4700 \text{ ml}}{208 \text{ ml}} = 22$$

$$\text{Rabbit dosage} = \frac{\text{Therapeutic dose in humans}}{\text{Blood volume ratio}} = \frac{100 \text{ mcg}}{22} \sim 5 \text{ mcg}$$

Since each syringe of octreotide contained a 50 mcg dose, the volume administered was intended to be 0.1 ml to obtain serum octreotide concentrations close to our intended concentration of 5.2 ng/ml. However, during the studies, personnel mistakenly administered an entire syringe to each subcutaneous subject, which increased the dosage by a factor of ten (versus intended dose).

Additionally, our original intended dosage would have rendered serum octreotide concentrations that exceeded the detection limits of the RIA kit used to detect sample octreotide concentrations (this was not discovered until after RIA analysis); therefore, with a dosage ten times that of the intended dosage, all subcutaneous animals' serum octreotide concentrations far exceeded levels that we were capable of detecting. For this reason, it became necessary to calculate serum octreotide concentrations in each subcutaneous animal at 30 minutes. In order to do this, we had to estimate octreotide volume of distribution in rabbits.

This group was originally intended to compare sublingual diffusion groups with a known therapeutic serum concentration; however, once we discovered that the animals were substantially overdosed, these calculations were used purely to distinguish magnitude of disparity between our SubQ group serum concentrations and known therapeutic serum octreotide concentrations in humans, as the latter was more relevant to determine therapeutic significance in the sublingual diffusion groups.

To calculate SubQ group serum octreotide concentrations at 30 minutes, first-order elimination rate equations were utilized, including:

$$C_0 = \frac{Dose}{Vd}$$

$$t_{1/2} = \frac{\ln(2)}{k}$$

$$C_t = C_0 * e^{-kt}$$

where C_0 is the original dose, V_d is the volume of distribution, $t_{1/2}$ is the half-life, k is the elimination rate constant, C_t is concentration at time t , and t is time in hours. Half-life was assumed to be 1.8 hours based on human data, and k was calculated to be 0.385. Since V_d for octreotide in rabbits could not be found, an estimate was calculated using the known V_d in humans (14 L), blood volume in humans (4.85 L), and rabbit blood volume by the following equation to render a V_{dr} of 606 ml for rabbits:

$$\frac{BV_r}{BV_h} = \frac{V_{dr}}{V_{dh}}$$

C_0 was then calculated by taking our initial dosage (50 mcg) and dividing by our calculated V_{dr} to obtain a value of 82.5 mcg/ml. Both C_0 and the calculated elimination rate constant were then plugged into the concentration equation with a $t=0.5$ to obtain concentration at time = 30 minutes for each rabbit. These values are shown in Table 9. The average SubQ animal serum octreotide concentration was more than 10 times greater than therapeutic levels in humans (5.2 ng/ml), and approximately 100 times greater than the average concentration in the +DC group (the sublingual group with the highest average serum octreotide concentration).

TABLE 9: Subcutaneous Injection Group Calculated Octreotide Serum Concentrations at 30 mins (ng/ml)

Rabbit #	Date	Weight (kg)	BVr (ml)	Vd (ml)	Co (ng/ml)	[Serum] ng/ml
41	16-Jun	2.90	203	587	85.2	70.3
45	16-Jun	3.08	216	623	80.2	66.2
53	17-Jun	2.90	203	587	85.2	70.3
59	20-Jun	2.99	210	605	82.7	68.2
62	21-Jun	2.99	210	605	82.7	68.2
Average:		2.98	208	601	83.2	68.6
Standard Deviation:		0.07	5	14	1.9	1.6

Experiment date, animal weights, calculated rabbit blood volume (BVr), volume of distribution (Vd), initial concentration (C_0), and serum concentrations at 30 mins. This group was intended to be used to as a gold standard of therapeutically significant serum octreotide concentrations; however, dosage far exceeded therapeutic levels – the average peak plasma concentration of our SubQ groups was more than 10 times greater than the lower limit of therapeutic octreotide concentration in humans (5.2 ng/ml). Average peak plasma SubQ concentration is approximately 100 times greater than serum octreotide concentrations at 30 minutes in the +DC stim group, the sublingual group with the highest serum concentrations.

Protocol Deviations

It should be noted that some of the experiments did not follow the protocol exactly due to errors/unforeseen variables during the experiment. After reviewing the concentration data from these particular animals and recalculating p value data, these deviations did not seem to significantly impact the validity of our results. These disparities were annotated on each animal's datasheet, and are as follows:

The first four Stimulated animals: Rabbits 42-43 (Positive DC Stimulation Group), 46 (AC Stimulation Group), and 47 (Negative DC Stimulation Group):

After completing the first four stimulated animals, it became apparent that we needed to increase the gauge of our electrode wire due to oral and hip electrode breakage. All four of these animals exhibited lower concentrations of serum octreotide than the average and median values in the other animals in their respective groups. Rabbits 42, 43, and 46 all exhibited the lowest octreotide concentrations in their respective groups (Positive DC Stimulation Group and AC Stimulation Group), while Rabbit 47 exhibited the second-lowest in the Negative DC Stimulation Group. It is possible that this smaller gauge of wire was not as effective at delivering the desired current to the animals and/or exhibited small fractures that were not observed until the experiment was complete (due to observed breakages that occurred with this gauge of wire after utilizing for a few experiments). However, two of these animals were in the Positive DC Stim group, which still displayed a statistically significant higher concentration of serum octreotide than the Baseline Oral Absorption Group.

Rabbit 46: AC Stimulation Group

This was the first experiment performed with the animal hooked up to the stimulation system, and thus was the operator's first opportunity to run the system during the absorption study. In addition to running the electrical system, the operator was also in charge of manually administering the oral octreotide drip and recording relevant times

during the duration of the study (start oral drip, start electrical stimulation, blood draws, cease oral drip, cease stimulation, etc.), as well as monitoring the voltages recorded on the oscilloscope. Due to the operator's unfamiliarity with performing all duties at once, the input voltage was set to 4 v peak-to-peak (which was our target voltage), but the frequency was not set, and therefore ran at the default frequency of the function generator (100 kHz) for the first 18 minutes of the experiment, after which the frequency was decreased to 20 Hz. Additionally, the operator neglected to record the voltage across the animal in this experiment; however, due to the other recorded voltage data for the AC Stimulation Group animals, it is estimated that the voltage and resulting current delivered to the animal was higher than our target of 4 mA (estimated at 8 mA based on other animal data). This particular animal did display a noticeably lower serum octreotide concentration, but only at $t=30$ mins as compared to the other animals in the AC Stim Group. This animal also had the smaller gauge electrode, as mentioned above, which may have decreased stimulation effectiveness/delivery.

Rabbit 50: AC Stimulation Group

This animal was started with a circuit input voltage of 4 volts peak-to-peak and exhibited twitching. The voltage was decreased until the twitching ceased, which was at 2 volts peak-to-peak. Each AC Stimulation Group animal thereafter was administered a V_{in} of approximately 2 volts peak-to-peak, which was adjusted slightly depending on how the animal tolerated stimulation. Additionally, due to the amount of

twitching upon administration of electrical stimulation, a higher-than-normal (as compared to the other experiments) amount of the octreotide drip was applied to wet the mucosa of the animal to decrease twitching. This resulted in the animal receiving a bit less of the oral octreotide drip for the duration of the experiment. During the 30 minute blood draw, the artery was constricted, and therefore a cardiac stick was performed to obtain the 30 minute blood sample for serum concentration analysis.

Rabbit 47: Negative DC Stimulation Group

Prior to the start of the experiment, the animal exhibited a tiny prick on the tongue associated with tweezers utilized during intubation. We were concerned this could corrupt our concentration data if the prick was not fully clotted and octreotide seeped straight into the blood stream; however, this prick turned out to be inconsequential, as this rabbit exhibited the second-lowest octreotide concentration at 30 minutes in the Negative DC Stimulation Group. The hip electrode in this animal had become brittle for unknown reasons by the end of the experiment and broke at the skin when the alligator clip was detached. This animal did appear to have a significantly lower serum octreotide concentration than three of the other animals in the Negative DC Stimulation Group; however, one other animal (Rabbit 54) in this group did exhibit lower concentrations than Rabbit 47 at each time point, so it is difficult to say whether the brittle electrode affected octreotide absorption. However, after this electrode breakage,

it was determined that we should switch to a larger gauge wire for our electrodes for the remainder of the study, as mentioned above.

Rabbit 63: Negative DC Stimulation Group

This animal displayed signs of light anesthesia towards the end of the experiment, and consequently was administered an additional half dose of anesthesia. Additionally, this animal exhibited an unexplained green ooze at the skin where the hip electrode entered/exited the skin. This did not appear to affect serum octreotide concentration.

Rabbit 60: Positive DC Stimulation Group

At t=11 minutes, stimulation was ceased for approximately 2 seconds to adjust the oral electrode connection to the circuit. This did not appear to affect the concentration of serum octreotide, as this particular rabbit had concentrations very close to the mean and median values of the other animals in the group.

6.3 Discussion

Since octreotide is administered to patients with chronic conditions such as acromegaly, carcinoid syndrome, and chemotherapy-induced severe diarrhea, it is desirable to explore alternate routes of delivery (other than parenteral routes typically used), particularly if these alternate routes are accompanied with higher patient

compliance, ease of use, and less discomfort. Octreotide cannot be administered orally due to denaturation in the gastrointestinal tract and hepatic first-pass metabolism; with the aid of an applied local electrical current, orotransmucosal delivery may provide a means with which to effectively and non-invasively deliver octreotide to patients in a chronic manner.

The findings from this pilot animal study were significantly positive and clearly demonstrate the ability of an applied electrical current to increase the serum concentration of sublingual octreotide in rabbits versus passive sublingual diffusion alone. Electrical stimulation of +4 mA direct current increased serum octreotide concentration by a factor of nine versus sublingual diffusion alone ($p=0.023$; statistically significant), and increased absorption rate by a factor of 28 (i.e., 2,700% increase in absorption rate) with high statistical significance (p -value of 0.0008) as compared to the Oral Baseline Absorption Group. For a direct current stimulus of -4 mA, the serum concentration was increased by a factor of seven versus sublingual diffusion alone ($p=0.08$; non-statistically significant), and the rate of octreotide absorption increased by a factor of 19x with borderline significance ($p=0.032$) when compared with the Oral Baseline Absorption Group. Alternating current (20 Hz) stimulus with an average of 2.3 mA peak-peak across the rabbits was less effective than the direct current stimulation groups (3x increase in serum concentration and 10x increase of rate of concentration change (on average) as compared to the unstimulated oral absorption group, but not statistically significant due to large variations).

In one animal in the +DC group and one animal in the –DC group, a decrease in animal mucosal resistance was observed. In these experiments, this change in resistance appeared to be on the order of tens to hundreds of ohms; however, sufficient data was not collected for these two animals, or for other study animals to draw decisive conclusions on how mucosal resistance changes over time in the presence of an electrical field; however, other studies³⁰ have shown a decrease in oral mucosa over time with the application of a direct current electric field. It is worth noting that this phenomena was not observed in any of the AC animals, and therefore may have played a role in the significant increase in octreotide absorption rate into the blood stream associated with both DC groups.

The first stimulated experiment we performed was on Rabbit 46, and as noted in the Results section, this animal received a 100 kHz 4 v peak-to-peak stimulation for the first 18 minutes of the experiment due to stimulation system operator inexperience and error. Even when this animal was excluded from our calculations, however, the recalculated p value (0.092) was not significantly different than the original p value (0.091), and therefore the errors made with this particular animal did not have a significant impact on our overall outcomes and findings. This animal was also one of the four animals that received a smaller-gauge electrode wire.

As mentioned in the Results section, one animal in the Negative DC Stimulation Group received a smaller-gauge electrode wire than the other animals in the group, and also

exhibited electrode breakage at the hip upon completion of the study. The p value was recalculated for the Negative DC Stimulation Group without this animal (0.093), and it was not found to be significantly different from the original p value calculated for this group (0.085). The other two animals that received a smaller-gauge electrode wire were in the Positive DC Stimulation Group, and since they had the lowest serum octreotide concentrations in this group, but the group was still statistically significant, a p value excluding these two animals was not calculated (since hypothetically their exclusion should further decrease the p value).

Although the electrical stimulus increased the rate of absorption significantly, the baseline rate of oral absorption was relatively very low. In humans, the lower limit of therapeutic serum concentration is approximately 5.2 ng/ml (100 mcg dose). The percentage of therapeutic dose was calculated for each sublingual group (Table 10). We found that the Baseline group exhibited serum octreotide concentrations that were about 1.4% of known therapeutic serum concentrations (70 times less than therapeutic levels); the +DC group exhibited serum octreotide concentrations that were 13% of known therapeutic concentrations (8 times less than therapeutic levels); the -DC group exhibited serum concentrations that were about 10% of known therapeutic levels (10 times less than therapeutic levels); and the AC group exhibited serum concentrations that were about 5% of known therapeutic levels (21 times less than therapeutic levels).

Again, these results clearly demonstrate the ability of an applied electrical field to significantly increase sublingual octreotide diffusion into the blood stream, while showing promise that therapeutic serum octreotide concentrations could potentially be achieved via this route of delivery. Since diffusion is proportional to the concentration differences across a barrier, theoretically oral octreotide concentration can be increased in the saliva to make sublingual absorption more effective.

TABLE 10: Comparison Between Sublingual Diffusion Groups Serum Octreotide Concentrations and Known Therapeutic Serum Concentration

Sublingual Group	Avg. [Serum] at 30m (ng/ml)	% [Therapeutic]
Baseline	0.07	1.4
+DC	0.68	13.0
-DC	0.54	10.3
AC	0.25	4.9

Comparison between Sublingual Diffusion Groups serum octreotide concentrations at 30 mins and therapeutic levels (5.2 ng/ml). Baseline group exhibited average serum levels that were 1.4% of known therapeutic concentrations; +DC exhibited average serum concentration at 30 minutes that was 13% of known therapeutic concentration; -DC exhibited average serum concentration at 30 minutes that was 10% of therapeutic concentrations; and AC group exhibited average serum concentrations at 30 minutes that was 5% of known therapeutic concentrations.

Though the stimulated animals in our study did not exhibit serum concentrations of octreotide high enough to be therapeutically significant, there is evidence that extending the time of exposure to octreotide, as well as increasing the concentration of the oral drip may result in blood octreotide concentrations closer to therapeutically

significant levels.²⁵ Lau et al. showed that transdermal iontophoretic delivery of octreotide acetate at a concentration of 5 mg/ml and a current of 0.15 mA resulted in serum octreotide concentration of approximately 2.2 ng/ml after approximately 3 hours of exposure, with an apparent bioavailability of 8.1%. This concentration is only half the calculated lower limit of therapeutically significant serum octreotide concentration (~5.2 ng/ml for a dose of 100 mcg at 25 minutes). Since the stratum corneum is the main barrier to diffusion across the skin, sublingual delivery may be even more significant given the same concentration and exposure duration since the sublingual mucosa lacks a stratum corneum. Additionally, the most effective concentration of transdermally administered octreotide was 100 times more than the concentration utilized in our study, and the maximum current utilized was 46 times less than in our study. It follows that utilizing our system at the same currents delivered in our study with durations and concentrations similar to that of Lau, et al., compounded with the fact that our system delivers octreotide across a membrane which lacks a stratum corneum should result in more effective systemic octreotide delivery than our pilot study and the transdermal study by Lau et al.

Additionally, Hau et al. showed that local transmucosal delivery of lidocaine through the buccal mucosa was significantly enhanced by utilizing a low-dc current (as in our study), coupled with electroporation (short, high voltage pulses) and absorption enhancement chemicals. It follows that both electroporation and/or enhancement

chemicals may potentially enhance systemic octreotide delivery in our system as well, and should be incorporated into future works.

6.4 Limitations

Although the outcomes of our experiments were largely positive and insightful, there are improvements (in addition to the mediating deviations from the protocol mentioned in the Results section) that could be made to enhance outcomes from future feasibility studies in the development of the SEP device.

Our experiments were designed to only last for 30 minutes based on the fact that we preferred to only administer one dose of anesthesia to each animal, and one dose was expected to last for approximately 45 minutes (giving us a window of time to get the animal and system set up, perform the experiment, euthanize the animal and harvest tissue). When both the concentration data and the rate change of concentration data are examined, however, it appears that serum concentration levels in the stimulated animals was still increasing at the termination of the experiment (30 mins), and had we been able to continue oral drip and stimulation we believe serum octreotide concentrations would have increased as well – possibly to the point of statistical significance in the negative DC stimulation group and the AC stimulation group.

Since the concentration gradient of octreotide across the sublingual mucosa plays a significant role in diffusion, it would be beneficial to perform an oral absorption study

with electrical stimulation utilizing octreotide acetate at higher concentrations to discern if achieving a therapeutic level of octreotide in the blood stream through sublingual absorption is feasible.

For AC stimulation, capacitive properties of the animals were not taken into account in the design of the precision current source; however, since these groups did not display substantially higher concentrations of octreotide in the serum, further studies to correct this design flaw and explore concentration results are not necessary.

Additionally, the oral electrode design was not ideal to ensure proper location of current delivery in the oral cavity. Development in the precision of this oral electrode should enhance the increase in octreotide absorption rate, and this factor most likely played a large role in the large disparities in serum concentrations between animals in the same stimulation groups. Likewise, oral drug delivery was not as precise as we would have liked, and could be improved upon by delivery via a local vehicle, either by a pill or patch, or by a method that would render a more precise rate of oral drip, such as an infusion pump. The localization factor of both these components likely contributed to the large disparities seen in concentrations between animals in the same stimulation groups.

7. CONCLUSIONS

By applying three distinct electrical stimulation patterns to the oral mucosa of rabbits in the presence of octreotide acetate, we've discovered that a positive direct current of approximately 4 mA produces a statistically significant increase in the serum concentration of octreotide that is nine times greater than that of sublingual absorption alone. Additionally, when the rate changes of octreotide serum concentration between each sample time (absorption rates) were investigated, both the positive direct current and negative direct current groups exhibited statistically significant higher octreotide absorption rates when compared to sublingual absorption in the absence of electrical stimulation (28 times greater, $p=0.0008$; and 19 times greater, $p=0.023$ respectively). While therapeutic serum octreotide concentrations were not obtained in this study, we believe that by increasing oral electrode and drug delivery efficiency, increasing the duration of stimulation and sublingual octreotide exposure to about 4-5 hours, and utilizing an oral octreotide drip concentration of 5 mg/ml, therapeutic serum octreotide concentrations are feasible. Though the mechanisms involved in increased diffusion and decreased resistance in the mucosa as a result of an applied electrical field are not fully understood, key factors include the charge of the constituent that is administered and convective transport that affects movement of both neutral and charged particles (electroosmosis).^{8,19}

We discovered that a device such as the Sublingual Electronic Pill may be feasible in the sublingual delivery of peptides, proteins, and/or biologics, and shows enough promise to be investigated further. Additional studies that could aid in the successful development of this technology include: studies utilizing larger groups of animals; studies to investigate the effects of utilizing a higher concentration oral drip;²⁵ studies that have a duration greater than 30 minutes, since it appears serum concentration was still increasing at this time; studies to determine feasibility in substances other than octreotide acetate; studies utilizing more efficient electrode and oral drug delivery designs; studies to assess synergistic benefits/efficiency of utilizing oral electrical stimulation in conjunction with absorption enhancers; studies utilizing direct current (iontophoresis) in tandem with high-voltage pulses (electroporation);¹⁹ and studies to determine ideal stimulation waveform and magnitude. This pilot study was a necessary first step in the direction of the successful realization of the SEP device.

7.1 Funding

This project is funded by the Department of Defense through DARPA (Defense Advanced Research Projects Agency) and USAMRMC (United States Army Medical Research and Material Command) ARO #58268-LS-DRP.

7.2 Consultants

John C. Criscione, Texas A&M University - Department of Biomedical Engineering

Maya Scott, Texas A&M University – Department of Veterinary Physiology &
Pharmacology

Michael Moreno, Texas A&M University – Department of Biomedical Engineering

Kenith Meissner, Texas A&M University – Department of Biomedical Engineering

Texas A&M University Comparative Medicine Program

Elizabeth Browder

Vincent Gresham

Andrea Taylor

Ryan Byrd

TAMU Physics Department Electronics Shop

Erwin Thomas III

Texas A&M University Veterinary Medical Teaching Hospital

Stephen Lagutchik

Sublingual Electronic Pill (SEP) Technologies, Inc.

REFERENCES

1. Adams, G.P. and L.M. Weiner. Monoclonal antibody therapy of cancer. *Nat. Biotechnol.* 23(9):1147-1157, 2005.
2. Ahsan, F., J. Arnold, E. Meezan, and D.J. Pillion. Enhanced bioavailability of calcitonin formulated with alkylglycosides following nasal and ocular administration in rats. *Pharm. Res.* 18(12):1742-1746, 2001.
3. Analog Devices, Inc. [Internet]. Low cost low power instrumentation amplifier – AD620 Datasheet - Revision H; c2003-2011 [updated 2011 Jul; cited 2012 Jan 12]. Available from: <http://www.analog.com/en/specialty-amplifiers/instrumentation-amplifiers/ad620/products/product.html>
4. Asgeirsson K.S., A. Agrawal, C. Allen, A. Hitch, I.O. Ellis, C. Chapman, K.L. Cheung, and J.F. Robertson. Serum epidermal growth factor receptor and HER2 expression in primary and metastatic breast cancer patients. *Breast Cancer Res.* 9(6):R75, 2007.
5. Banga, A.K. and Y.W. Chien. Iontophoretic delivery of drugs: fundamentals, developments and biomedical applications. *J. Controlled Release* 7:1-24, 1988.
6. Banga, A.K. and Y.W. Chien. Systemic delivery of therapeutic peptides and proteins. *Int. J. Pharm.* 48:15-50, 1988.
7. Bauer, W., U. Briner, W. Doepfner, R. Haller, R. Huguenin, P. Marbach, T.J. Petcher, and J. Pless. SMS 201-995: a very potent and selective octapeptide analogue of somatostatin with prolonged action. *Life Sci.* 31(11):1133-1140, 1982.

8. Bejjani, R.A., C. Andrieu, C. Bloquel, M. Berdugo, D. BenEzra, and F. Behar-Cohen. Electrically assisted ocular gene therapy. *Surv. Ophthalmol.* 52:196-208, 2007.
9. Benson, A.B. III, Ajani, J.A., Catalano, R.B., Engelking, C., Kornblau, S.M., Martenson, J.A. Jr., R. McCallum, E.P. Mitchell, T.M. O'Dorisio, E.E. Vokes, and S. Wadler. Recommended guidelines for the treatment of cancer treatment-induced diarrhea. *J. Clin. Oncol.* 22(14):2918-2926, 2004.
10. Bouwstra, J. and M. Ponc. The skin barrier in healthy and diseased state. *Biochim. Biophys. Acta.* 1758:2080-2095, 2006.
11. Campisi, G., L.I. Giannola, A.M. Florena, V. De Caro, A. Schumacher, R. Gottsche, C. Paderni, and A. Wolff. Bioavailability in vivo of naltrexone following transbuccal administration by an electronically-controlled intraoral device: a trial on pigs. *J. Control. Release* 145:214-220, 2010.
12. Chien, Y.W., P. Lelawongs, O. Siddiqui, Y. Sun, and W.M. Shi. Facilitated transdermal delivery of therapeutic peptides and proteins by iontophoretic delivery devices. *J. Control. Release* 13:263-278, 1990.
13. Ciach, T. and A. Moscicka-Studzinska. Buccal iontophoresis: an opportunity for drug delivery and metabolite monitoring. *Drug Discov. Today* 16:361-366, 2011.
14. De Caro, V., G. Giandalia, M.G. Siragusa, F.M. Sutura, and L.I. Giannola. New prospective in treatment of Parkinson's disease: studies on permeation of ropinirole through buccal mucosa. *Int. J. Pharm.* 429:78-83, 2012.

15. Feelders, R.A., L.J. Hofland, M.O. van Aken, S.J. Neggers, S.W.J. Lamberts, W.W. de Herder, and A.J. van der Lely. Medical therapy of acromegaly: efficacy and safety of somatostatin analogues. *Drugs* 69(16):2207-2226, 2009.
16. Giannola, L.I., V. De Caro, G. Giandalia, M.G. Siragusa, C. Tripodo, A.M. Floreno, and G. Campisi. Release of naltrexone on buccal mucosa: permeation studies, histological aspects and matrix system design. *Eur. J. Pharm. Biopharm.* 67:425-433, 2007.
17. Godin, B. and E. Touitou. Transdermal skin delivery: predictions for humans from *in vivo*, *ex vivo* and animal models. *Adv. Drug Delivery Rev.* 59:1152-1161, 2007.
18. Guy, R.H., Y.N. Kalia, M.B. Delgado-Charro, V. Merino, A. Lopez, and D. Marro. Iontophoresis: electrorepulsion and electroosmosis. *J. Control. Release* 64:129-132, 2000.
19. Hau, J., Li, S.K., Liu, C., and W.W.Y. Kao. Electrically assisted delivery of macromolecules into the corneal epithelium. *Exp. Eye Res.* 89:934-941, 2009.
20. Holbrook, K.A. and G.F. Odland. Regional differences in the thickness (cell layers) of the human stratum corneum: an ultrastructural analysis. *J. Invest. Dermatol.* 62:415-422, 1974.
21. Jacobsen, J. Buccal iontophoretic delivery of atenolol-HCl employing a new *in vitro* three-chamber permeation cell. *J. Control. Release* 70:83-95, 2001.
22. Kalia, Y.N., A. Naik, J. Garrison, and R.H. Guy. Iontophoretic drug delivery. *Adv. Drug Deliver. Rev.* 56:619-658, 2004.

23. Kornblau, S., Benson, A.B. III, Catalano, R., Champlin, R.E., Engelking, C.E., Field, M., Ippoliti, C., Lazarus, H.M., Mitchell, E., Rubin, J., Stiff, P.J., Vokes, E., and S. Wadler. Management of cancer treatment-related diarrhea: issues and therapeutic strategies. *J. Pain Symptom Manage.* 19(2):118-129, 2000.
24. Kutz, K., E. Nuesch, and J. Rosenthaler. Pharmacokinetics of SMS 201-995 in healthy subjects. *Scand. J. Gastroenterol.* 21:65-72, 1986.
25. Lau, D.T.W., J.W. Sharkey, L. Petryk, F.A. Mancuso, Z. Yu, and F.L.S. Tse. Effect of current magnitude and drug concentration on iontophoretic delivery of octreotide acetate (Sandostatin®) in the rabbit. *Pharm. Res.* 11(12):1742-1746, 1994.
26. Madhav, N.V.S., A.K. Shakya, P. Shakya, and K. Singh. Orotransmucosal drug delivery systems: a review. *J. Control. Release* 140:2-11, 2009.
27. Mannila, J., K. Jarvinen, J. Holappa, L. Matilaine, S. Auriola, and P. Jarho. Cyclodextrins and chitosan derivatives in sublingual delivery of low solubility peptides: a study using cyclosporine A, alpha-cyclodextrin and quaternary chitosan N-betainate. *Int. J. Pharm.* 381:19-24, 2009.
28. Mitchell, P. Erbitux diagnostic latest adjunct to cancer therapy. *Nat. Biotechnol.* 22(4):363-4, 2004.
29. Miyagishi, M. and K. Taira. siRNA becomes smart and intelligent. *Nat. Biotechnol.* 23(8):946-7, 2005.

30. Moscicka-Studzinska, A., E. Kijenska, and T. Ciach. Electroosmotic flow as a result of buccal iontophoresis – buccal mucosa properties. *Eur. J. Pharm. Biopharm.* 72:595-599, 2009.
31. Naik, A., Y.N. Kalia, and R.H. Guy. Transdermal drug delivery: overcoming the skin's barrier function. *Pharm. Sci. Technol. Today* 3(9):318-326, 2000.
32. Ottesen, L.H., A. Flyvbjerg, P. Jakobsen, and F. Bendtsen. The pharmacokinetics of octreotide in cirrhosis and in healthy man. *J. Hepatol.* 26:1018-1025, 1997.
33. Prausnitz, M.R. The effects of electric current applied to skin: a review for transdermal drug delivery. *Adv. Drug Delivery Rev.* 18:395-425, 1996.
34. Scheuplein, R.J. and I.H. Blank. Permeability of the skin. *Physiol. Rev.* 51(4):702-747, 1971.
35. Scholz, O.A., A. Wolff, A. Schumacher, L.I. Giannola, G. Campisi, T. Ciach, and T. Velten. Drug delivery from the oral cavity: focus on a novel mechatronic delivery device. *Drug Discov. Today* 13:247-253, 2008.
36. Senel, S., M.J. Rathbone, M. Cansiz, and I. Pather. Recent developments in buccal and sublingual delivery systems. *Expert Opin. Drug Del.* 9(6):615-628, 2012.
37. Senel, S., M. Kremer, K. Nagy, and C. Squier. Delivery of bioactive peptides and proteins across oral (buccal) mucosa. *Curr. Pharm. Biotechnol.* 2:175-186, 2001.
38. Singh, P., and H.I. Maibach. Iontophoresis in drug delivery: basic principles and applications. *Crit. Rev. Ther. Drug Carrier Syst.* 11:161-213, 1994.
39. Sloan, J.B. and K. Soltani. Iontophoresis in dermatology. *J. Am. Acad. Dermatol.* 15:671-684, 1986.

40. Tyle, P. Iontophoretic devices for drug delivery. *Pharm. Res.* 3(6):318-326, 1986.
41. Whitton, J.T. and J.D. Everall. The thickness of the epidermis. *Br. J. Dermatol.* 89:467-476, 1973.

VITA

Christina Marie Bolch is a graduate of the Dwight Look College of Engineering at Texas A&M University where she received her Bachelor of Science degree in Biomedical Engineering (2007) and Master of Engineering in Biomedical Engineering (2010). She received her Doctor of Philosophy in Biomedical Engineering from Texas A&M University in 2012. Presently, she has one publication in press and one publication in submission, and is listed as a partial inventor on an issued patent. Her research interests include the role of mechanics in cardiovascular disease processes and device-based therapies for cardiovascular pathologies. She now works as a Project Engineer at CorInnova, Inc. where she continues to develop these ideas and therapies.

Christina may be reached at 3120 TAMU, Department of Biomedical Engineering, Texas A&M University, College Station, TX 77843-3120. Her email address is stina1115@gmail.com.