

## SMART OPERATIONS OF AIR-CONDITIONING AND LIGHTING SYSTEMS IN A GOVERNMENT BUILDING FOR PEAK POWER REDUCTION

Y. Al-Hadban  
Associate Research  
Scientist

G.P. Maheshwari  
Senior Research  
Specialist

D. Al-Nakib  
Senior Research  
Associate

A. Al-Mulla  
Associate Research  
Scientist

R. Alasseri  
Principal Research  
Technician

Department of Building and Energy Technologies  
Environment and Urban Development Division  
Kuwait Institute for Scientific Research  
P.O. Box 24885, 13109, Safat, Kuwait  
[yhadban@safat.kisr.edu.kw](mailto:yhadban@safat.kisr.edu.kw)

## ABSTRACT

This paper presents the achievements of implementing smart operations strategies for air-conditioning (A/C) and lighting systems in Justice Palace Complex (JPC), Kuwait during the summer 2007. The peak load of this building was 3700 kW. The achievements are summarized as direct savings between 13:00 and 22:00 h by closing supply and return air fans of 52 air-handling units with a connected load 400 kW, and an additional saving of 550 kW during the same period by optimizing the cooling production and distribution. Also an all time saving of 22 kW by de-lamping, and additional saving of 27 kW through TDC of lighting were achieved. In conclusion project achieved an overall reduction in power demand of around 20% between 13:00 to 17:00 h and reduction ranging from 7% to 15% between 17:00 to 20:00 h.

**Key words :** Peak power, air-conditioning, time-of -day control, de-lamping.

## INTRODUCTION

In Kuwait, national peak power, primary controlled by air-conditioning (A/C) of the buildings commonly occur at around 15:00 h. The average power increase between 13:00 and 15:00 h is 4% that amounts to approximately 400 MW. Considering that most of the government offices operate between 07:00 and 14:00 h, and their total power demand exceeds 600 MW; the national power demand in the country can be frozen at 13:00 h level by effectively operating the A/C and lighting in the government buildings. During the summer 2007, smart operation strategies for A/C and lighting systems were developed and tested in a number of governmental buildings in Kuwait as one of the solutions to reduce the national peak electrical power demand. The smart operation strategies implemented in these buildings included Pre-Closing Treatment (PCT) between 13:00 and 14:00 h and Time-of-Day Control (TDC) after 14:00 h. Also de-lamping was carried out in some of the buildings to readjust the higher than recommended illumination levels. This paper presents the findings of

such a scheme implemented in the Justice Palace Complex (JPC) during 2007 summer. More importantly, it presents an approach and methodology for implementation of this scheme that can be followed by countries in the region.

JPC building, commissioned in 1985, houses judicial organs and their agencies. The building is square in plan and has a sky-lit courtyard in its center. It has clear-single glazed windows and un-insulated walls and roof. Occupancy period for this building is between 7:30 and 14:00 h, however, several zones, such as court rooms are occupied after working hours. It has a peak load of around 3,700 kW. The fans of the air-handling units (AHUs) and fan coil units (FCUs), and the secondary chilled water pumps run round the clock. Also the number of chillers in operation is changed only on seasonal basis. JPC building has a BAS that has on/off facility for AHUs but there is no specific control for lighting system.

## DESCRIPTION OF AIR-CONDITIONING AND LIGHTING SYSTEMS

Air-conditioning and lighting systems are the major power users in the JPC like in any other building in Kuwait and the region. Although there are miscellaneous other users, the present study has been confined to A/C and lighting systems.

## Air-Conditioning System

JPC has a central A/C system with recently replaced water-cooled centrifugal chillers. Three chillers each with a cooling capacity of 854 RT are expected to meet the building peak cooling demand. Additionally, there is a stand-by chiller. A single set of chilled water pumps, unlike the common practice in modern A/C systems using a combination of primary and secondary pumps, circulate the chilled water at a constant flow between the chillers and the miscellaneous users. A schematic of the cooling production and distribution equipment is shown in Fig. 1.

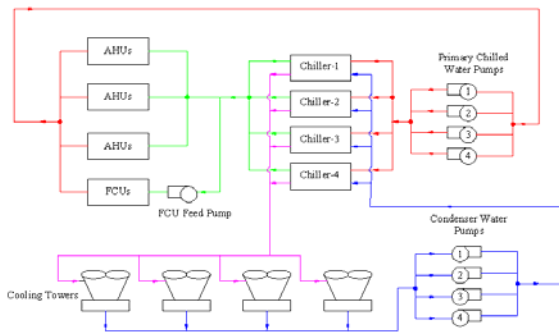

Figure 1. Schematic of air-conditioning system in JPC

The connected load for the different motors is given in Table 1. The connected load for the cooling production and distribution auxiliaries (CPADA) is 1118 kW, while the same for the three chillers is 1,920 kW. The air distribution through 98 AHUs and 900 fan-coil units (FCUs) is with a constant flow. Each AHU has one supply air fan and two return air fans. The connected load of all the supply air fans is 638 kW while that of return air fans is 342 kW. In addition, 900 FCUs has a connected load of 180 kW. Thus, the total connected load of the air distribution system is 1160 kW. Also, there is a booster pump of 45 kW for feeding chilled water to 900 FCUs. The AHUs and FCUs are with 3-way flow regulating valves, accordingly the chilled water flow in the system was constant.

Table 1. Connected Load of Major Power Users in JPC Building

Equipment	Quantity	Unit Power (kW)	Total Power (kW)
Chillers	3+1	640	1920
Chilled water pumps	3+1	160	480
Condenser water pumps	3+1	160	480
Cooling tower fans	3+1	37/12	111
FCU chilled water pump	1+1	45	45
Air-handling units			
- Supply air fans	98	2.2-22	638
- Return air fans	196	0.17-17	342
Fan coil units	900		180
Lighting	lot		915
<b>Total</b>			<b>5111</b>

+1=Stand by

### Lighting System

Lighting system in the interior of the complex comprises mostly of energy-efficient fluorescent tubes. However, the illumination level in many areas exceeds the recommended values specified by the Ministry of Electricity and Water (MEW) through the Energy Conservation Code of Practice (MEW/R-1, 1997). JPC has a lighting load of around 980 kW.

Total connected load of A/C and lighting in JPC is 5111 kW. And the percentage share of chillers, CPADA, air distribution and the lighting system based on their connected load is 37, 22, 21 and 19%, respectively as shown in Fig. 2.

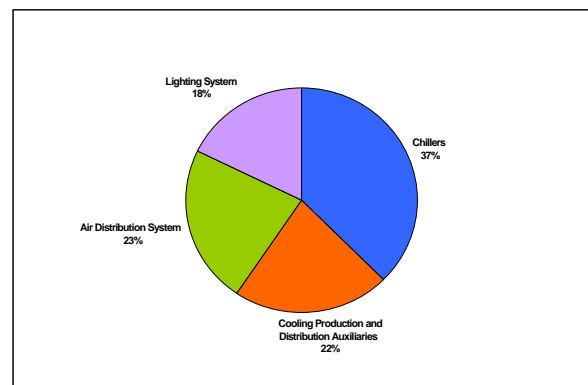

Figure 2. Major consumers of power in JPC

### APPROACH AND METHODOLOGY

Development of the Smart Operation Strategies was based on modifying the current practices of operating A/C system and other facilities in the governmental and institutional buildings to minimize their power demand during the national peak power demand period. Baseline performance was established before implementing the smart operation strategies. The smart operation strategies were developed and finalized in consultation with the facility manager. Methodology used for peak power reduction included Pre-Closing Treatment (PCT) for A/C system, Time-of-Day Control (TDC) for A/C and lighting systems, and reduction of excessive lighting by de-lamping.

#### PCT for A/C System and TDC for A/C and Lighting Systems

A common practice in Kuwait is to operate A/C systems with a fixed comfort temperature and continuous operation of various cooling distribution systems such as pumps and fans, in spite of the fact that most of the governmental and institutional buildings operate between 07:00 and 14:00 h, five days a week. Although, the operation of the lighting system is somewhat controlled. Operation of the A/C

system in relation to the building occupancy, termed as TDC is an excellent option to save a large amount of energy without adversely affecting the quality of comfort during the occupancy period. Likewise, availing the stored cooling in the building's thermal mass, satisfactory comfort conditions may be maintained between 13:00 and 14:00 h with less than required cooling production. This scheme defined as PCT, if applied in such buildings by limiting the cooling production at 13:00 h can help to achieve a 2% reduction in national power demand between 13:00 and 14:00 h.

PCT was the first to be implemented between 13:00 and 14:00 h, when the building was still occupied. It was observed that many areas in the building were practically empty after 13:00 h. As a result, PCT and TDC were applied together for these areas. These areas were fed by as many as 52 AHUs. The total connected load of the supply air and return air fans of these AHUs was around 400 kW. Also, the TDC for the lighting was implemented as well in some selected areas after 13:00 h. Simultaneously, the operation of the cooling production and cooling distribution system was optimized by switching off one of the two chillers along with their auxiliaries such as the chilled water pumps, condenser water pumps and the fans of the cooling towers. Full details of the equipment in operation before and after the implementation are given in Table 2. During the PCT and TDC implementation, comfort levels were monitored using 10 portable sensors, HOBO model U12-012 in different part of the building.

Kuwait has many buildings with very high peak power demand, PCT followed by TDC for A/C and lighting equipment can be effective tools to reduce national peak power demand by 4% MEW, 2007). These two schemes could freeze the national peak power at the level of 13:00 h. However, these measures have to be implemented with utmost care to provide thermal and visual comfort and to ensure that the temperature rise is acceptable during the PCT period and optimum pre-cooling is provided to compensate for thermal build up during the TDC period.

#### De-lamping

De-lamping refers to removing the extra lights from their fixtures. This is an excellent way to rectify the over sizing of the lighting equipment. Usually this is a costless procedure and can be undertaken during the time of maintenance. In areas where light switches control more than one fixture and where the light levels exceed the recommended values, de-lamping is the most suitable remedy. To correctly reform the over utilization of lights by de-lamping, site measurement data for light levels for different tasks

areas are collected and lamps in the areas where the illumination levels exceed the recommended ones are removed. Device used to measure the light levels is called lux meter. It is recommended to remove the ballasts along with the lamps, since ballasts do consume energy. De-lamping was implemented in the corridors and lobbies, while the offices were excluded. Lux levels in the corridors were reduced from 385 to 220 (Fig. 3), while in the lobbies they were reduced from 465 to 235. The recommended illumination levels for corridors and lobbies are 100 and 150 lux, respectively.

Table 2. A/C Equipment in Operation Before and After Implementation of PCT and TDC

Equipment	Before	After
Chillers	2	1
Chilled water pumps	3	1
Condenser water pumps	2	1
Cooling tower fans	3 (1 H, 2L)	3 L
FCU chilled water pump	1	1
Air-handling units	98	46
Supply air fans	196	92
Return air fans		
Fan coil units	900	900

H=High speed; L=Low speed

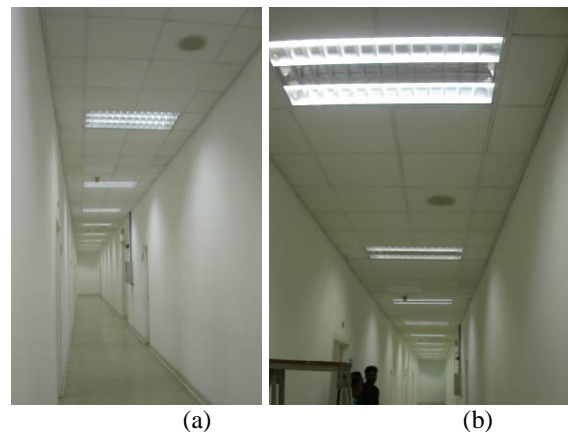

Figure 3. A corridor (a) before (b) after de-lamping

#### RESULTS AND DISCUSSION

The peak load of JPC was 3700 kW. Direct savings of 389 kW were achieved between 13:00 and 22:00 h by closing supply and return air fans of 52AHUs. Also, an additional saving of 550 kW during the same period was achieved by closing the two of the three chillers and their

auxiliaries. Furthermore De-lamping achieved an all time saving of 14 kW and an additional savings of 23 kW through TDC of lighting after 14:00 h. In conclusion project achieved an overall reduction in power demand of around 20% between 13:00 to 1700 h and reduction ranging from 7% to 15% between 17:00 to 20:00 h as shown in Fig. 4.

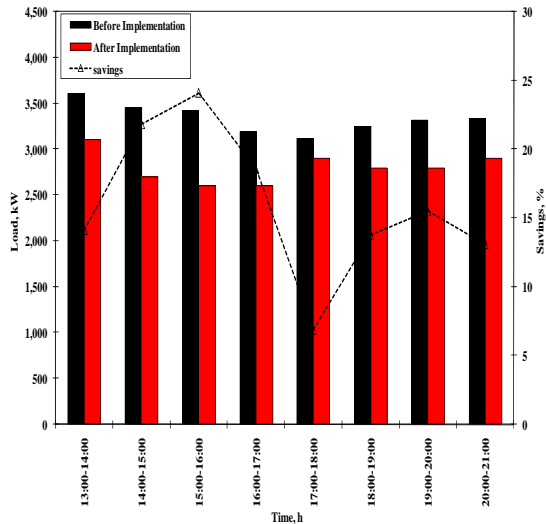

Figure 4. Power demand reduction in JPC during PCT and TDC implementation

The temperature build up during the PCT implementation between 13:00 and 14:00 h of less than 2°C as shown in Fig. 5 was not high enough to adversely affect the occupants' comfort level. Furthermore, considering that unlike the JPC, most buildings in Kuwait have more energy efficient envelop with insulated walls and roof and high quality double glazing (Al-Mulla et al, 2008), the temperature build up in such buildings is going to be significantly lower. Thus, implementation of PCT in the governmental and institutional buildings an hour before their occupancy period is safely recommended as a demand side management to reduce the national peak power demand.

#### CONCLUSIONS AND RECOMENDATIIONS

1. PCT, one hour prior to closing hour of an office building is found to have acceptable temperature build up of less than 2oC.
2. TDC is a simple and effective strategy for minimizing power demand of A/C and lighting systems after the working hours. Available

building management systems in most of the buildings are sufficient for TDC implementation.

3. PCT for A/C system and TDC for A/C and lighting systems should be applied to all the government buildings in Kuwait. These measures will not only limit the national peak power demand at the 13:00 h level, they will reduce the electricity consumption as well.
4. De-lamping, should be implemented wherever it is applicable. This is necessary to ensure energy efficiency and visual comfort.

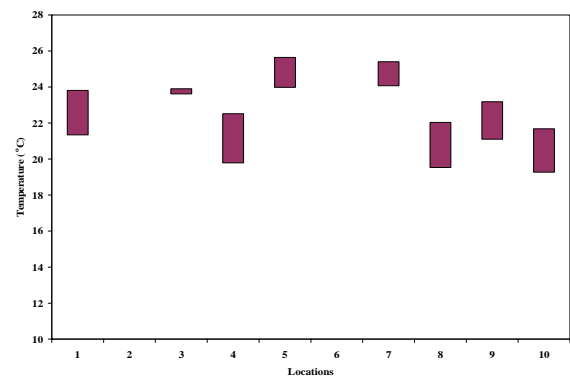

Figure 5. Space temperature rise in JPC during PCT implementation between 13:00 and 14:00 h

#### REFERENCES

1. Al-Mulla, A. , G.P. Maheshwari, D. Al-Nakib, A. ElSherbini, F. Alghimlas, H. Al-Taqi, Y. Al-Hadban, H. Ishaqali, R. Alasser, A. Al-Awadhi and A. Al-Farhan 2008. Smart Operation Of Air-Conditioning And Lighting Systems In Government Buildings For Peak Power Reduction, Final Report, KISR Report 9320, Kuwait.
2. MEW/R-1. 1997. Regulations for electrical installations. Fourth Edition. Ministry of Electricity and Water, Kuwait.
3. MEW. 2007, Statistical data book - Electricity and Water, Ministry of Electricity and Water, Kuwait.