

*SANTO ANTONIO DE TANNÁ*: STORY AND RECONSTRUCTION

A Thesis

by

TIAGO MIGUEL FRAGA

Submitted to the Office of Graduate Studies of  
Texas A&M University  
in partial fulfillment of the requirements for the degree of

MASTER OF ARTS

December 2007

Major Subject: Anthropology

*SANTO ANTONIO DE TANNÁ*: STORY AND RECONSTRUCTION

A Thesis

by

TIAGO MIGUEL FRAGA

Submitted to the Office of Graduate Studies of  
Texas A&M University  
in partial fulfillment of the requirements for the degree of

MASTER OF ARTS

Approved by:

Chair of Committee,	Luis Filipe Vieira de Castro
Committee Members,	Kevin J. Crisman
	James M. Rosenheim
Head of Department,	Donny L. Hamilton

December 2007

Major Subject: Anthropology

## ABSTRACT

*Santo Antonio de Tanná: Story and Reconstruction.* (December 2007)

Tiago Miguel Fraga, Lic., Lusiada University

Chair of Advisory Committee: Dr. Luis Filipe Vieira de Castro

Buy a puzzle, assemble it, and destroy its original box. Take the puzzle, go to a lake, throw the puzzle in the lake, and leave it for a few weeks. Return to the lake and try to rebuild the puzzle from the remaining pieces. Such is the challenge of the research goals presented on this abstract – the reconstruction of a Portuguese frigate, *Santo Antonio de Tanná*, from its submerged remains. This thesis focuses on the mechanisms of reconstructing the ship, including the thought process, new computer tools, and imagination required for an archaeologist to be a detective of lost eras.

The main objective was to understand the construction of a late Seventeenth-century Portuguese frigate. Frigates were responsible for patrolling the seas, intercepting fast-moving vessels, re-supplying military trading stations, and protecting trade routes. The existence of Portuguese frigates was known from historical records, but *Santo Antonio de Tanná* is the only frigate identified in the archaeological record. As such, its reconstruction should enable scholars to better understand the actual capabilities of seventeenth century frigates.

A particular challenge in this study was ascertaining the manner in which *Santo Antonio de Tanná's* construction reflected the state of affairs of the Portuguese trade network. Although their construction methods were advanced, the Portuguese adopted a shipbuilding design that was not able to compete as well in the new conditions of a changing global context. This study clearly demonstrate that cargo capacity was given greater emphasis than either speed or maneuverability, illustrating the on-going necessity of the Portuguese to build military ships with cargo capacity sufficient for minimal trade, even at the expense of speed.

These were just the first steps in terms of what could be learned from the reconstruction. The best method to understand the ship, a three-dimensional object, was to recreate it into a three-dimensional environment in order to create a more accurate model. The resulting model permitted research to extend beyond the limits of the individual line drawings through the added benefit of being able to calculate hydrodynamics, sailing characteristics, and other data based on the ship's morphology.

To my Parents, Carlos and Paula, may I be as good a parent.

## ACKNOWLEDGMENTS

I previously avoided reading the acknowledgments page in the works I came across during my studies. However, I now understand the necessity and value of such pages. And so I must thank the wonderful people that helped me through three years of bad food, sleep deprivation, and, surprisingly immense fun. First, to Filipe Castro for the patience he demonstrated during our work. To Robin Piercy and Jeremy Green, thanks for digging up the subject. To Kevin Crisman and James Rosenheim for making sure that Filipe would not be always right. To Donny Hamilton, who supported me and gave me so many opportunities. To my mentor Jean-Yves Blot for pointing to the right direction. To my moral compass Maria Luisa Blot for keeping me on the right road. To my parents Carlos and Paula and sisters Maria João, Monica, Vanessa, and Emanuele for the dedication and support they showed during this adventure. To Nancy Barnes, without you this thesis would never exist. To Rebekah Luza, Karen Taylor, Cindy Hurt, and Milissa Kennedy, you saved my hide several times and I am deeply grateful. To the team of the International Student Office, thank you. To my friends and colleagues, George and Bryana Schwarz, Alexis and Alexa Catsambis, Randal Sasaki, Jon Swanson, Mark Polzner, Wendy VanDeiveforden, Erika, Erik, Dante Bartoli, Laurie Lind, Claudia, Melissa, Chastity, Sam Li, Sam, Joshua Levin, Joshua, Chris and Katie, for all their patience, wonderful support and for enriching my life, here I state my deepest gratitude.

Finally, to the one that has my heart, and did not mind waiting, Sandra Louro Conde Fraga. The waiting is over, love.

## TABLE OF CONTENTS

	Page
ABSTRACT .....	iii
DEDICATION .....	v
ACKNOWLEDGMENTS.....	vi
TABLE OF CONTENTS .....	vii
LIST OF TABLES .....	x
LIST OF FIGURES.....	xi
CHAPTER	
I INTRODUCTION.....	1
II PORTUGAL AND EUROPE IN THE SEVENTEENTH CENTURY	7
III HISTORY OF THE FRIGATE.....	20
Nomenclature .....	20
The Modern Age frigate.....	26
Ship classification .....	37
IV HISTORY OF <i>SANTO ANTONIO DE TANNÁ</i> .....	45
V HISTORY OF THE FORT <i>SÃO JESUS</i> IN MOMBASA .....	53
Background .....	53
The architect.....	58
Fort design.....	59
Fort construction .....	64
Organization of the fort .....	65
History .....	67
VI WRITTEN SOURCES FOR RECONSTRUCTION .....	80

CHAPTER	Page
Portugal .....	81
Spain.....	85
England.....	89
France.....	91
VII ICONOGRAPHIC SOURCES FOR RECONSTRUCTION.....	100
VIII ARCHAEOLOGICAL REMAINS .....	123
Surviving hull remains .....	123
Information for the line drawings.....	125
Measurements.....	126
Scantlings .....	128
Keel .....	128
Stem post.....	128
Stern post.....	129
Frames .....	130
Keelson.....	133
Mast step .....	134
Mast partners / stanchions.....	135
Stanchions .....	136
Hull planking.....	138
Ceiling.....	138
Stringers .....	138
Deck clamp .....	139
Hanging knees.....	144
IX RECONSTRUCTION OF <i>SANTO ANTONIO DE TANNÁ</i> .....	145
Overall dimensions.....	145
The hull shape .....	152
Reconstructed scantlings .....	168
Keel .....	173
False keel.....	175
Stem .....	175
Stemson.....	176
Stern post.....	177
Deadwood knee.....	178
Transom .....	178
Frames .....	181
Keelson.....	197
Stringers .....	197



CHAPTER	Page
Deck beams and stanchions .....	199
Hatches .....	203
Wales .....	203
Waterway wale .....	205
Caprail .....	205
Planking .....	207
X CONCLUSIONS .....	213
WORKS CITED .....	219
VITA .....	231

## LIST OF TABLES

TABLE		Page
1	1670 French Ship classification .....	40
2	<i>Gloria Britannica's</i> 1689 listing .....	42
3	English ship classification .....	43
4	Seventeenth-century 50-gun frigates and fourth rate models.....	147
5	Planking areas of the ship based on the <i>Relação</i> .....	208

## LIST OF FIGURES

FIGURE		Page
1	Habsburg dominated regions of Europe.....	8
2	Spanish-Portuguese maritime empire in the 1600s.....	9
3	Portugal's maritime empire in 1600s .....	14
4	The Omani empire.....	15
5	The Mogul empire in 1700.....	16
6	The East Indies in 1700s .....	18
7	Brazil expansion and gold areas in the eighteenth century .....	19
8	<i>A fragata</i> by Fernandez.....	22
9	Tagus River <i>Fragata</i> as it looks today .....	23
10	A representation of <i>fregata aquila</i> , common name frigatebird .....	26
11	Jacob Gerritsz Loef, Witte de With's action with Dunkirkers, 1641 .....	28
12	Portuguese <i>patacho</i> of 18 guns .....	29
13	A Dutch <i>patacho</i> , possibly a Dunkirker.....	31
14	Robert Dudley Dunkirk-built ship plate.....	32
15	A French light frigate .....	34
16	Seventeenth-century model of an English 50-gun ship.....	37
17	Diu, Bassein, Bombay and Goa .....	47
18	Mozambique, Zanzibar and Mombasa .....	51

FIGURE		Page
19	The <i>Monomotapa</i> empire by Joao Texeira 1630.....	54
20	The area of the fort's influence .....	57
21	Aerial view of Fort <i>São Jesus</i> .....	60
22	Mombasa and Fort <i>São Jesus</i> by Bocarro .....	61
23	Plan of 1610 by Manuel Godinho de Herédia.....	66
24	The location of the revolting cities.....	71
25	Plan of Fort <i>São Jesus</i> as it stands today.....	78
26	<i>Resolution</i> , a ship built by Deane painted by Willem Van der Velde the younger.....	92
27	Anonymous 1691 table of timbers .....	95
28	Drawings of a French frigate at La Rochelle .....	97
29	Robert Dudley Dunkirk-ship midsection .....	102
30	Bushnell drawing.....	103
31	Deanes drawing .....	104
32	P. Chaillé 42-Gun Frigate.....	105
33	A model of a 44-gun fourth rate.....	107
34	Fifty-gun warship dated to the 1650s of English design.....	108
35	The model of the <i>Mordaunt</i> , a fourth-rate warship built in 1681 at Deptford .....	108
36	An unknown 50-gun warship .....	109
37	Scale model of a 50-gun warship from 1685 .....	109
38	Unidentified fourth rate of the last quarter of the seventeenth-century.....	110

FIGURE	Page
39 Unidentified 44-gun warship dated from the last decade of the seventeenth century .....	110
40 Unidentified English 50-gun warship dated to the last decade of the seventeenth century .....	111
41 Unidentified fourth rate 48-gun warship .....	112
42 Warship pierced for 46 guns .....	113
43 <i>Prins Carl</i> a Danish 50-gun warship, launched at Nyholm 15 October 1696.....	113
44 Fourth rate English warship of 52 guns .....	114
45 Danish warship of 50 to 54 guns built in the last years of the seventeenth century.....	115
46 The stern of <i>Nuestra Señora de la Concepción y Las Animas</i> .....	116
47 Detail of the stern of <i>Nuestra Señora de la Concepción y Las Animas</i> ; the text on the corner details the deck heights.....	117
48 The profile view of a 26-gun frigate .....	117
49 <i>Album de Colbert</i> Plate 12 .....	120
50 <i>Album de Colbert</i> Plate 19 .....	121
51 <i>Album de Colbert</i> Plate 37 .....	122
52 Plan of the 1979 excavation .....	124
53 Photograph MR181L20, detail of site plan and interpretation .....	130
54 Photograph MR4R-26 the bow is to the left .....	131
55 Surviving length of the keelson, notice the scarves .....	134

FIGURE	Page
56 Photograph MRL169L 19 notice the boards on the port side hole, the bow is to the left .....	136
57 Photograph of a stanchion <i>in situ</i> .....	137
58 Surviving port pieces.....	141
59 The picture MR3L06 which is the one that shows more clearly piece A .....	142
60 <i>Serre-bauquires, serre-goutieres</i> and <i>serregoutiere</i> .....	143
61 The interceding curves .....	149
62 Amidships initial and final section.....	151
63 Initial ship lines with overall dimensions.....	153
64 Original section lines from the Mombasa excavation taken from the interior of the ceiling.....	154
65 Diagonals, the Portuguese diagonal is the <i>Santo Antonio de Tanná</i> but transferred upwards to originate from the maximum breadth.....	157
66 <i>Santo Antonio de Tanná</i> initial hull shape .....	158
67 Master frame section. ....	160
68 European panel shapes .....	162
69 Stern panel of <i>Santo Antonio de Tanná</i> .....	164
70 A wooden angel that decorated the stern of the <i>Santo Antonio de Tanná</i> .....	165
71 Wooden statue of a small boy recovered from the stern .....	166
72 <i>Santo Antonio de Tanná</i> bow .....	169
73 Sheer plan of the <i>Santo Antonio de Tanná</i> ., 42-gun version of the 1680s.....	170

FIGURE	Page
74 Full breadth plan of the <i>Santo Antonio de Tanná</i> , 42-gun version of the 1680s .....	171
75 Bow and stern body plans of <i>Santo Antonio de Tanná</i> .....	172
76 <i>Santo Antonio de Tanná</i> tridimensional tentative lines drawings .....	173
77 Keel and ends of the vessel .....	175
78 Stem assembly of vessel showing the keel, stem and stemson .....	176
79 Stern area of the vessel .....	180
80 Stern area of the vessel with pieces labeled .....	181
81 Framing pattern of the <i>Santo Antonio de Tanná</i> .....	183
82 Section of <i>Santo Antonio de Tanná</i> 's hull at the master frame .....	184
83 Three-dimensional view of the master-frame on the keel .....	185
84 Section of <i>Santo Antonio de Tanná</i> 's hull at the frame 15 forward .....	186
85 Three-dimensional view of frame 15 forward on the keel .....	187
86 Section of <i>Santo Antonio de Tanná</i> 's hull at the frame 30 forward .....	188
87 Three-dimensional view of frame 30 forward on the keel .....	189
88 Section of <i>Santo Antonio de Tanná</i> 's hull at the frame 31 forward, cant frame .....	190
89 Three-dimensional view of frame 31 forward, cant frame on the keel .....	191
90 Section of <i>Santo Antonio de Tanná</i> 's hull at the frame 20 aft .....	192
91 Three-dimensional view of frame 20 aft on the keel .....	193

FIGURE	Page
92 Section of <i>Santo Antonio de Tanná</i> 's hull at the frame 35 aft .....	194
93 Three-dimensional view of frame 35 aft on the keel .....	195
94 Section of <i>Santo Antonio de Tanná</i> 's hull at the frame 39 aft .....	196
95 Three-dimensional view of frame 39 aft .....	197
96 Photograph of the port side <i>dormente dos baileus</i> and hanging knees, facing aft .....	198
97 Master-frame showing the stringers, with their Portuguese names on the left .....	200
98 View of <i>Santo Antonio de Tanná</i> showing the deck beams .....	202
99 Hatches position in <i>Santo Antonio de Tanná</i> .....	204
100 The <i>Santo Antonio de Tanná</i> master-frame, showing hull elements .....	206
101 <i>Santo Antonio de Tanná</i> 's master-frame three-dimensional view .....	207
102 The <i>Santo Antonio de Tanná</i> master frame showing planking areas .....	209
103 Master frame, dark gray shows known remains, and light gray display proposed solutions .....	210
104 Three-dimensional breadth view of the <i>Santo Antonio de Tanná</i> .....	211
105 Three-dimensional sheer view of the <i>Santo Antonio de Tanná</i> .....	212



## CHAPTER I

### INTRODUCTION

Maritime archaeology studies the interaction of humankind and the nautical environment. This interaction can be expressed in material remains such as harbors, ships, or coastal improvements; or in cultural spheres such as trade networks, exclusive economic areas, and national waters. Nautical archaeology is a sub discipline of maritime archaeology and focuses primarily on the study of ships and shipwrecks. Its main objective is the reconstruction of ships and boats based on documentary and archaeological evidence, and the understanding of their evolution through time. One of the principal research methods of nautical archaeologists is a type of reverse engineering in which the individual components of a shipwreck are taken apart and reassembled in order to understand the manner in which they were originally designed, fashioned, and assembled.

Economic, demographic, social, and political changes often influence the ways ships were designed and built; therefore, the study of shipbuilding history is greatly helped by the study of history and social change.

This thesis addresses a number of important questions pertaining to the shipbuilding practices of the Portuguese. Its main objective was to determine if it was possible to reconstruct the seventeenth century Portuguese frigate *Santo Antonio de*

---

This thesis follows the style of *American Journal of Archaeology*.

*Tanná* from documentary and archaeological evidence, and to understand the way in which it was built.

This study was made possible by the discovery of the actual shipwreck off the coast of Kenya. Initially called the “Mombasa Wreck,” the remains were identified as the 42-gun frigate *Santo Antonio de Tanná*.<sup>1</sup>

Found by local divers Conway Plough and Peter Philips in 1960, at a depth of 15m, and located in the old harbor of Mombasa, Kenya, *Santo Antonio de Tanná*'s site consisted of about 40m of preserved hull. The port side of the ship was almost completely missing, but the starboard side survived up to the first deck. This allowed for an effective reconstruction of the ship's hull, which was the first step required for the study of the ship's general characteristics and capabilities. The shipwreck was excavated between 1976 and 1981 by a joint team of the Institute of Nautical Archaeology and the National Museum of Kenya. The reconstruction work presented in this thesis results from the analysis of the excavation field data, and textual and iconographic data on shipbuilding.<sup>2</sup>

Given the fact that by the late seventeenth century European warships were standardized to a certain extent, the hypothetical reconstruction of the *Santo Antonio de Tanná* hull was also a reconstruction of a late seventeenth century Portuguese frigate.<sup>3</sup> Further work on this tentative reconstruction should help to provide a better understanding of the

---

<sup>1</sup> Thompson 1988, 9.

<sup>2</sup> Piercy 1977, 1978, 1979, 1980.

<sup>3</sup> Esparteiro 1987.

building process and performance of a Portuguese frigate during this period. It was also the first step in attempting to apply the concept of architectural signatures to Portuguese or Iberian ships of this time.<sup>4</sup>

Not much was previously known about Portuguese shipbuilding of the seventeenth century. Several studies have been published pertaining to the construction of ships in Spain during the second half of the seventeenth century, but very little information survives in Portugal regarding this matter.<sup>5</sup> Previous studies on Portuguese shipbuilding have more often than not been dedicated to traditional boats and traditional shipbuilding, and only a few archaeological studies have been conducted pertaining to the oceangoing ships of the post medieval period.<sup>6</sup> Several Portuguese ships have been “salvaged” by treasure hunters and have therefore contributed almost nothing to the understanding of the problems under analysis. The few in-depth archaeological studies in existence have presented only a fragmented image of Iberian and Portuguese shipbuilding across the centuries. For the seventeenth century, there was no single authoritative study of Portuguese shipbuilding. Therefore, many unanswered questions arose in this field of study, especially in view of the naval reorganization that occurred during that century, the increasing specialization of merchant and naval craft, and the scientific advances that provided a new understanding of winds, currents, and other nautical matters. For

---

<sup>4</sup> Crumlin-Pederson 1991; see also Oertling 1989; see also Oertling 2001.

<sup>5</sup> Serrano Mangas 1992, 1985; see also Gazstañeta Iturribalzaga 1992.

<sup>6</sup> Octavio Lixa Filgueiras has a vast bibliography on regional craft (1988), and Pimentel Barata on post-medieval theoretical documents on shipbuilding. For archaeological studies see Alves 2001, and Castro 2005.

centuries, ships were a central tool in the Portuguese overseas trade network. In the seventeenth century, Portugal ruled an extensive, though shrinking maritime empire that had extended around the world and was perpetually dependent on ships.

Among the important innovations of the second half of the seventeenth century was a new technique for fighting at sea by aligning the ships in a long line of battle; subsequently, a new type of ship was developed to fight in this capacity. It was called a ship of the line and its smaller expression was the frigate.

Frigates were responsible for patrolling the seas, intercepting fast vessels, supplying military installations, and protecting trade routes. In the case of the Portuguese, frigates were fairly well documented, but only *Santo Antonio de Tanná* has been found and excavated by archaeologists. This was why the wreck is such an invaluable opportunity as a case study that can shed light on the actual construction and capabilities of these vessels.

Chapter II provides a brief summary of the status of Europe and the role of Portugal in the second half of the seventeenth century. It enunciates the emergence of the two rival European powers in the East Indies, England and Holland, which ended Portuguese European hegemony in the region. The chapter also explains some of the changes in Portuguese policy regarding that region.

Chapter III discusses the origin and transformation of the frigate into the light warship utilized by all European sea powers in the seventeenth century, and addresses some hypotheses regarding its historical and geographical provenience.

Chapter IV describes the career of *Santo Antonio de Tanná* and the events that led to its loss in Mombasa harbor. This chapter starts with a short introduction to the shipyards where the ship was built; follows with a description of the ship's known voyages prior to its demise, includes a brief mention of a few persons known to have been associated with *Santo Antonio de Tanná*, and ends with a short account of the ship's discovery in the 1960s by skin divers.

Chapter V presents the history of Fort *São Jesus*, its military organization, the successive sieges in the late seventeenth century, the voyage of *Santo Antonio de Tanná* to supply the garrison, and its loss. This chapter includes the reasons for the construction and successive expansions of the fort, as well as a brief biography of the architect responsible for its design and construction.

Chapter VI gives a summary of the known seventeenth century treatises on nautical archaeology, including those which originated in Portugal as well as those from countries which were influential in Portuguese ship construction. This chapter details the content of each treatise and explains its value, or non-value, as a source for reconstruction. It ends with a mention of the treatises that were not accessible to the investigator in time to be included in this thesis.

Chapter VII analyses several seventeenth century iconographical sources that were available to this study at the time of reconstruction, and provides information on their provenience. This chapter also describes the existing line drawings and models from the same period as *Santo Antonio de Tanná* with an explanation of their potential value to the ship's reconstruction.

Chapter VIII presents a critical analysis of the scantlings and archaeological information derived from the excavation of *Santo Antonio de Tanná*.

Chapter IX describes the steps taken in the ship's reconstruction, the difficulties encountered, and the achieved solutions. It starts with an analysis of the ship's main dimensions, followed by a description of the process used to understand the hull shape. It ends with a presentation of a proposed scantlings list for *Santo Antonio de Tanná*.

Chapter X concludes the thesis and presents several avenues for the continuation of this study.

## CHAPTER II

### PORTUGAL AND EUROPE IN THE SEVENTEENTH CENTURY

The seventeenth century was a century of profound change in Europe.<sup>7</sup> Concentration of power in the hands of absolute rulers, economic and political aspirations, and differences between religious ideologies fuelled many conflicts.<sup>8</sup> The Habsburgs, including Spain's maritime and continental empire, were in a position of economic, political, and military dominance of Europe in the first decade of the seventeenth century (Fig. 1).

With the inclusion of Portugal and its maritime possessions in his empire in the early 1580s, Philip II of Spain (also known as Philip I of Portugal) found himself in control of the largest maritime empire the world had ever seen (Fig. 2).

This was not a comfortable political position in the European context. His power, as well as the dominance of his Habsburg successors, was continuously contested by other European nations.

---

<sup>7</sup> Corvisier 1977.

<sup>8</sup> Corvisier 1977, 209-11.



Fig. 1. Habsburg dominated regions of Europe.





Fig. 2. Spanish-Portuguese maritime empire in the 1600s.

Holland rose as a maritime world power during the first half of the seventeenth century, and England and France challenged Dutch power in the second half of the century. As the century progressed France eventually replaced Habsburg Spain as the principal power in Europe.<sup>9</sup> The whole European continent was greatly influenced by France for the next half century, certainly from a political point of view, but also from a cultural one. France was the dominant culture and ended the century in the pinnacle of political and cultural dominance with the reign of Louis XIV (1643-1715).

---

<sup>9</sup> Corvisier 1977, 218.

The two principal maritime adversaries of Spain and Portugal, Holland and England, were also ascendant in the seventeenth century. In the early years of the century the Dutch East India Company (*Verenigde Oostindische Compagnie* or V.O.C.) was formed with the dual purpose of conducting trade in the East Indies and fighting the enemies of the Republic, which basically included any competitors in the vicinity. Portuguese and Spanish dominance in the Indian and Pacific Oceans was soon challenged, and throughout the first half of the seventeenth century the V.O.C. effectively employed naval blockades to limit Portuguese commerce. Goa, the Portuguese East Indies capital, was isolated in 1603, and Malacca, an important Portuguese commercial center was attacked in 1606.<sup>10</sup> In 1619 the V.O.C. established its own capital in Batavia and start choking the Portuguese trade from Goa to Malacca, using a base in Singapore from 1627 onwards.<sup>11</sup>

Slowly replacing Portugal as the principal European maritime presence in Asia, in 1638 the V.O.C. took control of several important pepper production locations in Ceylon. Although it would take another three decades to effectively expel the Portuguese from that island, Holland thereafter became the principal supplier of pepper to Europe.<sup>12</sup>

---

<sup>10</sup> Although significant the attack on the Malacca fortress was a failure and the Dutch suffered heavy casualties (Chaudhuri 1998, 90-1).

<sup>11</sup> Disney 1981, 40.

<sup>12</sup> Boxer 1992, 118-9; it is also necessary to state that the introduction of a new type of vessel, the *Fluit*, and refined shipbuilding techniques greatly enhanced the Dutch ability to challenge Portugal in the East Indies (Barbour 1930).

At the end of the sixteenth century England became a maritime power and an important player in the European political theatre, even though the country's maritime expansion in the first half of the seventeenth century was restricted by Dutch power and its internal politics hampered by corruption and civil war between 1642 to 1660. This period of inner strife did not, however, leave England outside the European political stage. In the second half of the seventeenth century England started to threaten the integrity of the Spanish and Portuguese Empires, damaging their trade networks around the world as well as the Dutch Empire in the East. Although the initial emphasis of England was the purchase of spices, Dutch competition and subsequent fall of prices in the European market forced England to look for more profitable alternatives.<sup>13</sup> The discovery of an insatiable European market for Indian cloth gave the English a profitable alternative that reshaped the structure of their empire by the end of the seventeenth century, and saw them concentrating their efforts in India and gradually abandoning the Indonesian trading areas.<sup>14</sup> During the following century this policy allowed the English East Indies Company to become the most important European trader in Asia.<sup>15</sup> By the late seventeenth century the English were well established on the path that led to their maritime dominance in following centuries. Possession of strategic ports such as Bombay (offered in 1661 by the Portuguese as part of Princess Catherine of Bragança's

---

<sup>13</sup> Marshal 2001, 274.

<sup>14</sup> Marshal 2001, 277.

<sup>15</sup> Marshal 2001, 264.

dowry in her marriage to Charles II [1660-1685]), Madras, and Calcutta, provided the English with a strong hold on the major points of inter-Asian trade.<sup>16</sup>

According to some authors, during its emergence in the fifteenth and sixteenth centuries, the Portuguese presence in the world followed three separate paths. The first path was the establishment of trade dominance in the East Indies. This was supported by small garrisoned trade posts and fortresses, as well as a strong maritime presence that allowed the Portuguese to be the first intermediary in the sale of Indian products in Europe. The second path was the coastal colonization of Africa without any policy of inland penetration until the seventeenth century. Small coastal towns were primarily used as trading posts supplied by local rulers, used mainly for the trade of slaves and gold from Africa to Europe. The third path was the effective occupation and colonization of lands in Brazil. This endeavour required a strong Portuguese presence and relied heavily on the importation of African slaves. Brazilian undertaking was mainly agricultural. Sugar, tobacco, and timber were cultivated or harvested and exported to Europe. Land occupation and exploration required, however, a strong effort of colonization, a much different strategy from the almost nominal presence on land that characterized the Portuguese expansion in Asia.<sup>17</sup>

Portuguese Brazilian trade was at first carried out by a merchant community that became more aware of the potential of the land, which was much more promising and less risky

---

<sup>16</sup> Marshal 2001, 278-9.

<sup>17</sup> Albuquerque 1989, 8.

than investment in the India trade. Brazilian trade was less regulated and less controlled by the crown, thus giving the merchant community more freedom and better profits.

As the heavy administrative and defensive structures were paid through the profits of the trade, the East Indies Empire sometimes looked less appealing than Brazilian exploration (Fig. 3).<sup>18</sup> In spite of the problems, the East Indies trade was nevertheless responsible for the majority of the gross net income of Portugal.

During the seventeenth century, Indian trade profits fell. It was a century of loss for the Portuguese empire: Serião, in the Kingdom of Pegu (Burma) was lost in 1612; Ormuz (Hormuz) fell in 1622 to an Anglo-Persian force; Mascate (Muscat) was lost to the Omani in 1650; the ports of Canará (Kanara region, India) in 1654; and Mombasa in 1698.<sup>19</sup> The Portuguese saw the appearance of a number of formidable enemies in the East. The Shah of Oman expanded his control from the Gulf of Oman and took possession of Africa's east coast, from Tana River (Kenya) to Matwara (Tanzania), by conquering the Portuguese areas of Mombasa, Zanzibar, and Quiloa (Fig. 4). The Mogul Empire consolidated its power over a large part of the Indian Subcontinent (Fig. 5). In Japan, the main source of silver for the Portuguese East Indies trade, the Tokugawa dynasty united the country and ended almost two centuries of civil war.<sup>20</sup> In 1639 the Tokugawa went on to close Japan to all Portuguese visitors.<sup>21</sup>

---

<sup>18</sup> Serrão 1993, 71.

<sup>19</sup> Disney 1981, 70; see also Boxer 1992, 119-20; see also Subrahmanyam 1993, 207.

<sup>20</sup> Subrahmanyam 1993, 208.

<sup>21</sup> Boxer 1992, 119.



Fig. 3. Portugal's maritime empire in 1600s.

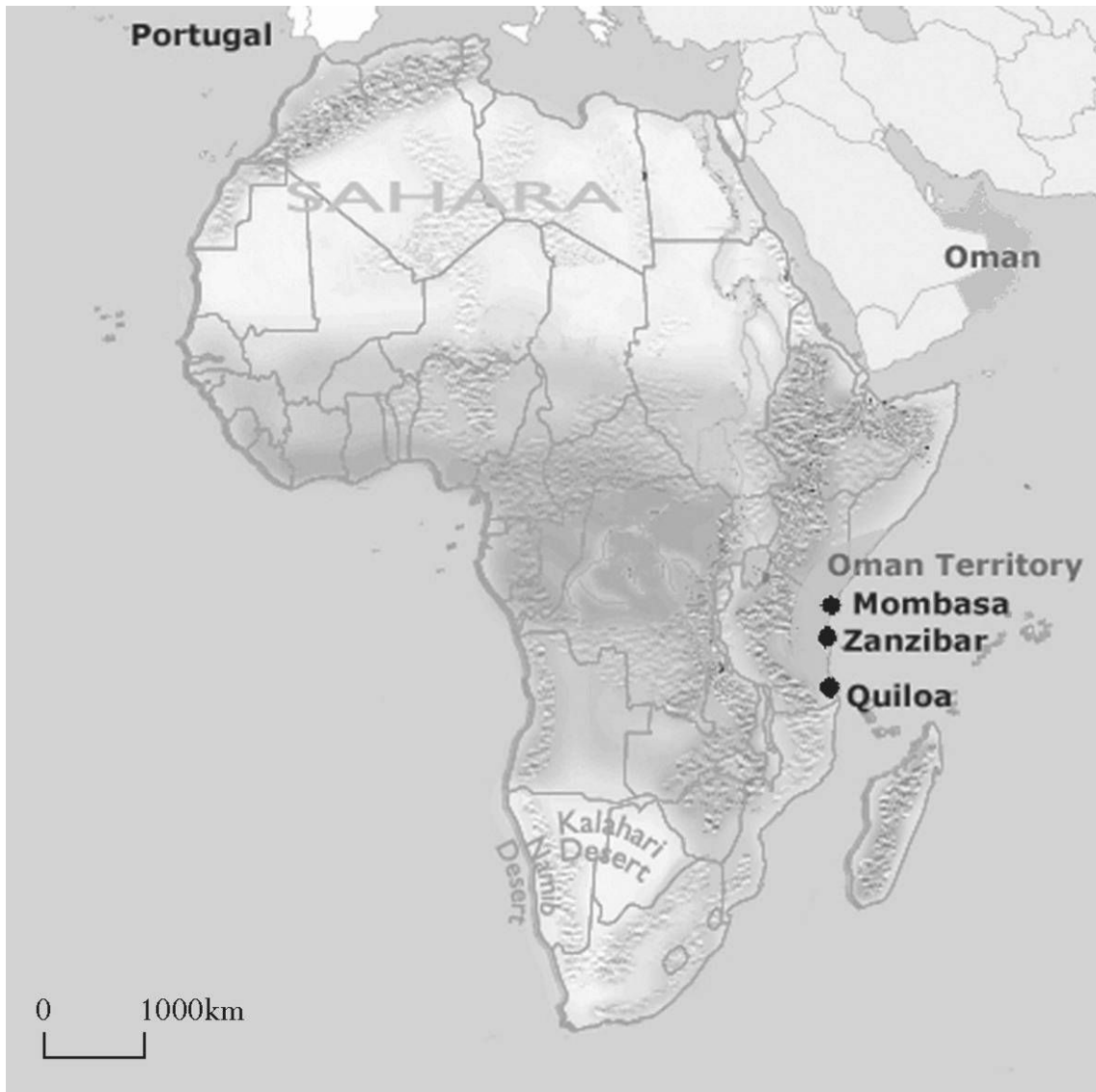

Fig. 4. The Omani empire.

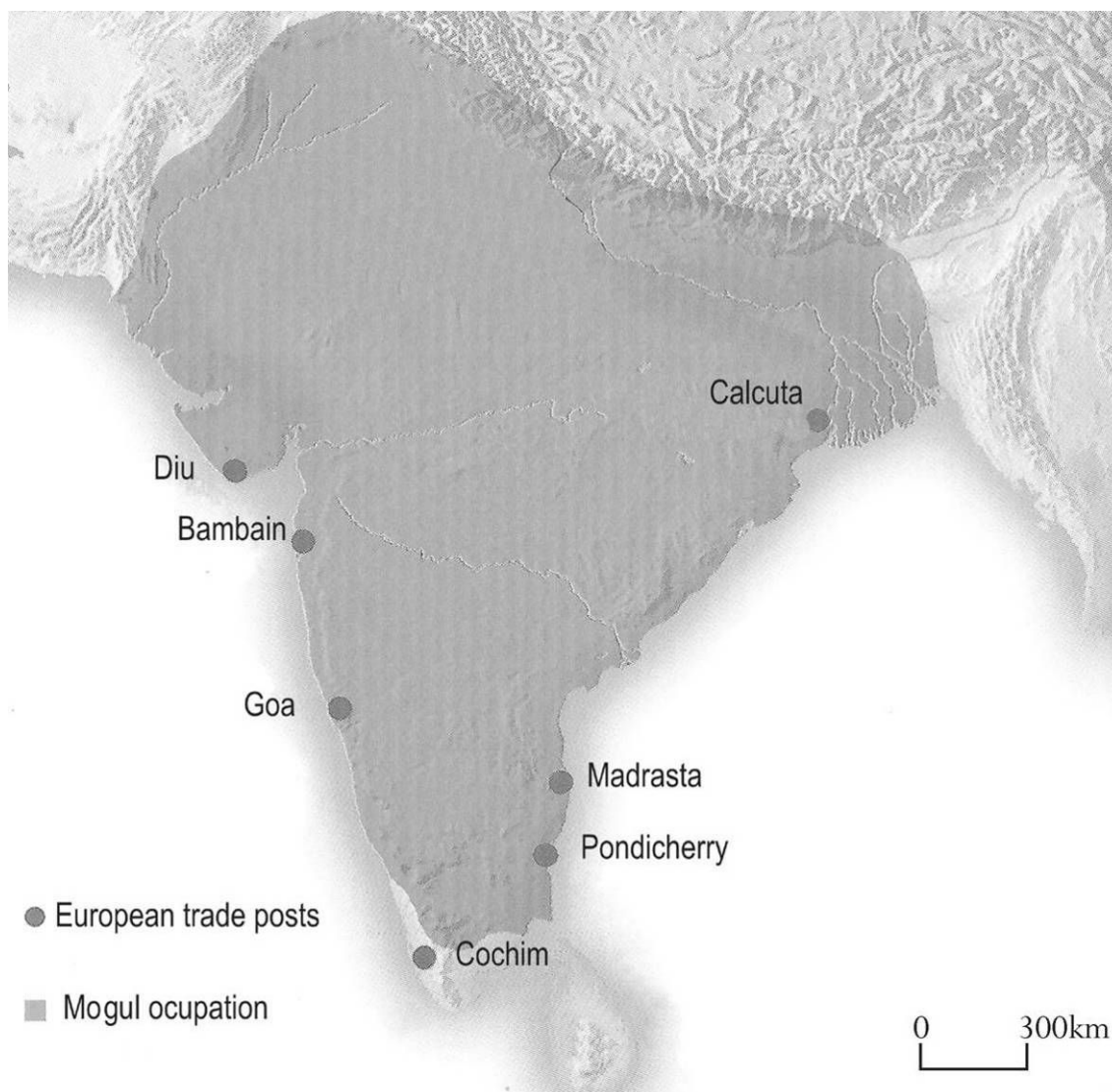

Fig. 5. The Mogul empire in 1700.

The difficulties felt locally all over the Portuguese Empire were worsened by the country's political problems in Europe. Forced by the trade ban decreed by King Philip II, Dutch merchants sailed to India during the first half of the century followed by



English ships. Dutch and English pepper imports to Europe brought the prices down, worsening the Portuguese economic position.

In this environment of decline the loss of strategic positions on the East African coast changed the political map of the Portuguese Empire as well (Fig. 6). In 1640 Portugal regained its political independence with the support of England; the new Portuguese king, John IV (1640-1656), started another costly war, this time against Spain, in order to consolidate his power and against Holland to regain the territories lost during the Habsburg Dynasty. The Portuguese crown became increasingly aware of the potential of Brazil as a replacement for the diminishing returns from the East Indies trade.<sup>22</sup> Brazil's importance in the crown's revenues had already increased with the growth of the sugar, tobacco, and timber trades in the early decades of the seventeenth century.<sup>23</sup> However, in the last years of the seventeenth century the discovery of important gold resources made Brazil the preoccupation of the Portuguese crown, replacing the East Indies trade (Fig. 7).<sup>24</sup> In the following century Brazilian gold allowed for the financial support of Portuguese international and national policies. Moreover, it not only yielded a readily available source of income, it also increased the volume of trade through the most important Portuguese ports as merchants from all corners of Europe came to trade their goods for the freshly arrived gold. With the gold found in Brazil, Portugal could import luxuries from all over the world, as well as ships and guns. And there was a new kind of

---

<sup>22</sup> Serrão 1993, 98.

<sup>23</sup> Mauro 1988, 238-40.

<sup>24</sup> Monteiro 1996, 6-7.

warship developing in Europe, whose accomplishments in the world navies was going to make it a symbol of naval power: the frigate.

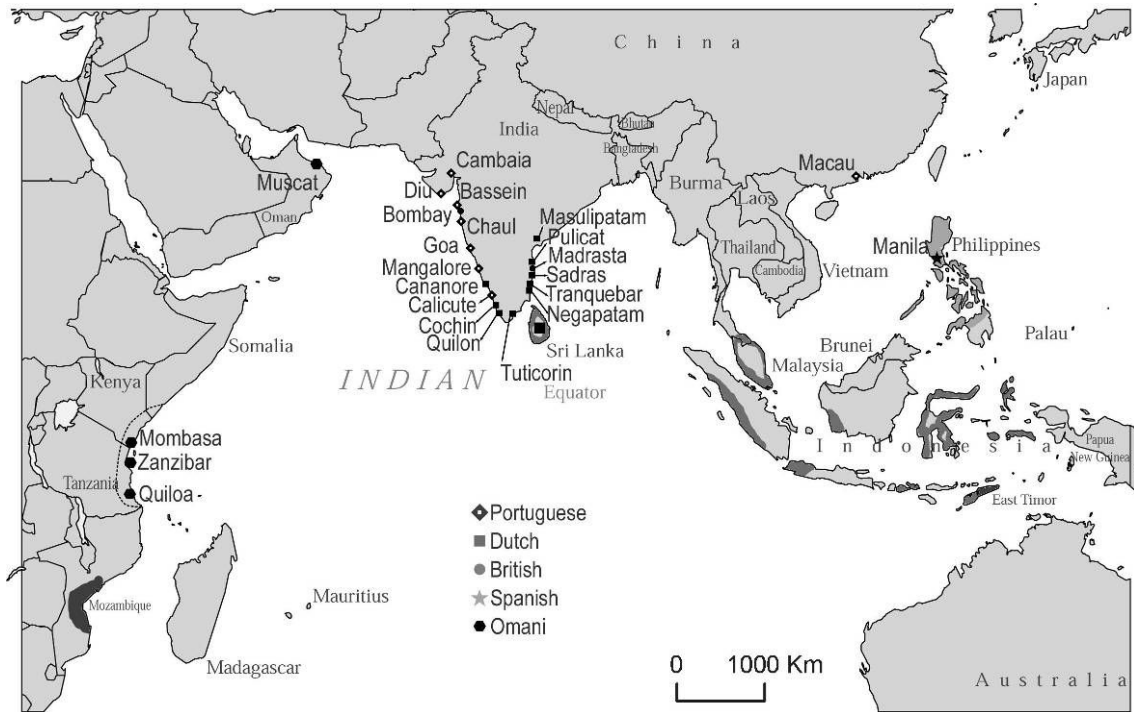

Fig. 6. The East Indies in 1700s.



Fig. 7. Brazil expansion and gold areas in the eighteenth century. (After Magalhaes 1998, 57.)

### CHAPTER III

#### HISTORY OF THE FRIGATE

##### Nomenclature

The word *fragata*, meaning frigate, was used in Portugal from at least 1616 and was initially applied to small transport vessels that sailed the Tagus River.<sup>25</sup> However, the origins of this word in Portugal are not clear. It seems to have derived from the Italian word *fregata*, a term used in the fourteenth century to designate a vessel whose characteristics are unknown to us. Its literary debut seems to have happen in Boccaccio's *Decameron* (IV. 6.6), the celebrated mid fourteenth century collection of stories:<sup>26</sup>

sí per l'ombra e sí per lo destro d'una fontana d'acqua freddissima che v'era, s'erano certi giovani ciciliani, che da Napoli venivano, con una lor fregata raccolti.<sup>27</sup>

Soon after, in 1462, the Italian term *fragata* appeared associated with a type of small ship used for personal transport.<sup>28</sup> According to James John Pontillo, the word reappeared in a letter from Naples in 1535, still referring to a small ship.<sup>29</sup> Again, in 1587, the term *fragata* was given to a small vessel of no more than 50 tons burden and

---

<sup>25</sup> Leitão and Lopes 1990, 274; see also Kochiss 1978, 169-85.

<sup>26</sup> Ciciliot 2005, 147.

<sup>27</sup> [...] as well for the shade as of the comfort afforded by a cool water spring that was there, some Sicilian youths, that came from Naples, had put in with their frigate. (*Decameron IV.6.6*)

<sup>28</sup> Ciciliot 2005, 147.

<sup>29</sup> Pontillo 1975, 279.

by 1599 the term was associated with a type of small bark.<sup>30</sup> At present, there is neither a date nor a reason why this word became associated with warships. That the large, agile, and fast birds of the southern seas were later given this name perhaps allows us to suppose that the early small *fragatas* were already swift vessels.

As mentioned above, the first mention of *fragatas* in Portugal dates to 1616, and occurred in association with the Tagus boats that ferried cargo from ships to shore. These vessels were assigned to harbors and belonged to individual ship owners or merchants. Such entrepreneurs dressed the masthead of these small ships with their company colors.<sup>31</sup>

These single-masted lighters were small vessels, 6 to 7 m in length and 1 to 2 m in breath, and had no deck except for small fore and aft half decks. Fernandez, in his *Livro de Traças de Carpintaria*, described three such vessels and drew two of them (Fig. 8).<sup>32</sup>

This designation of small cargo vessels working as tenders or transporting merchandise from one bank of the Tagus River to the other endured into the twentieth century when it referred to a small lighter with one fore-and-aft sail and a stay sail, and painted with bright colors (Fig. 9).<sup>33</sup>

---

<sup>30</sup> Pontillo 1975, 279

<sup>31</sup> Leitão and Lopes 1990, 274.

<sup>32</sup> Fernandez 1989, 58V - 9V, 133V - 4.

<sup>33</sup> Carrasco and Peres 1997, 19.

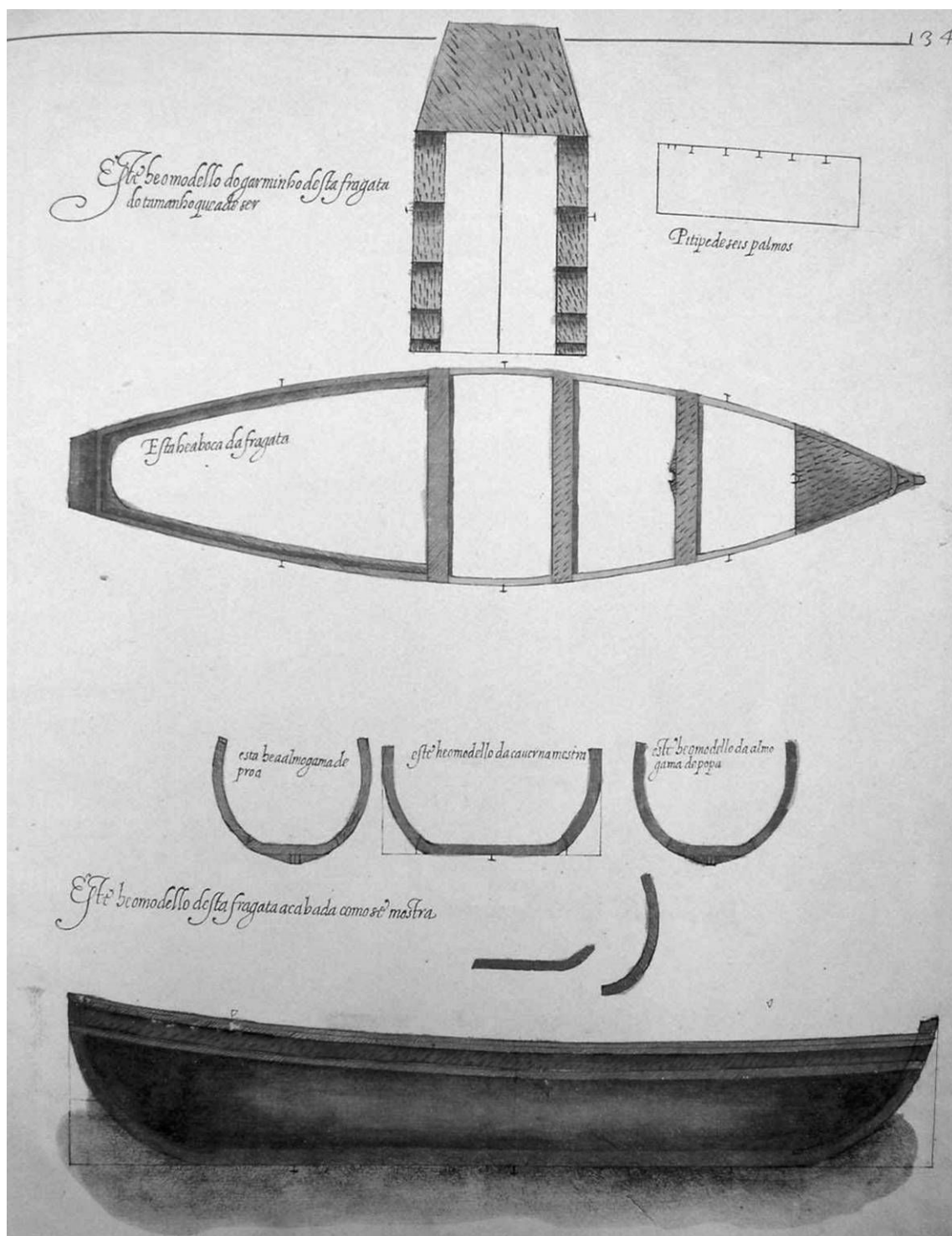

Fig. 8. A *fragata* by Fernandez. (From Fernandez 1983, 134.)

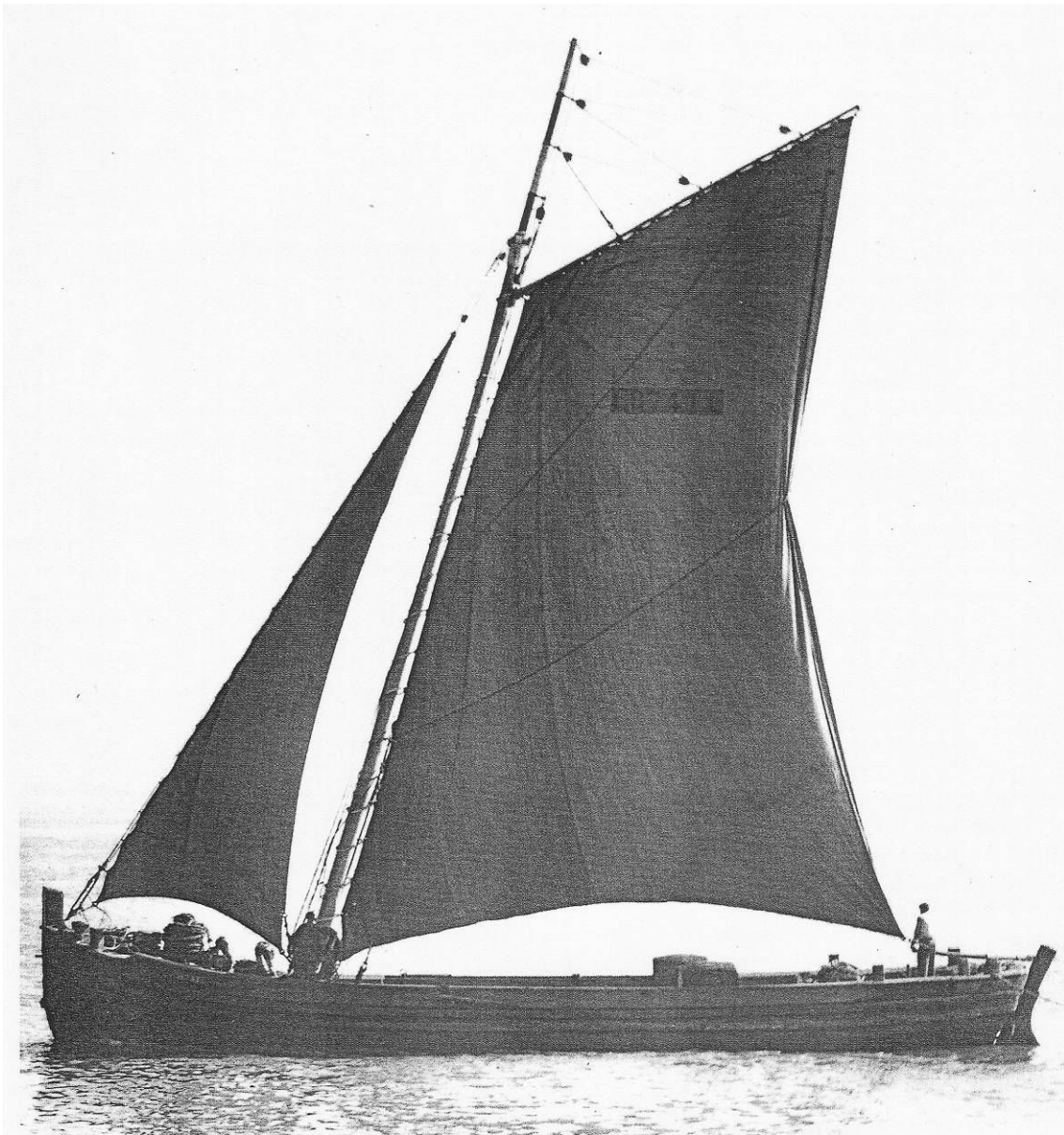

Fig. 9. Tagus River Frigata as it looks today. (From Carrasco and Peres 1997, 18.)

Nevertheless, by the mid seventeenth century the definition of a frigate had changed in France, extending to a much larger type of ship. According to Father Georges Fournier in his 1643 edition of *Hydrographie*, frigates were:

Single decked vessel, long and armed with guns, which also has an upper deck, but which is smaller than the brigantine, it is to be compared with the ancient ships with two banks of oars, one at the bow and one at the stern. In the Mediterranean, they usually accompany the galleys to scout and to carry news quickly. In the Atlantic they are some two-decked frigates also, and they are but middling warships, driven by sail and oars.<sup>34</sup>

The origin of these modern frigates is not presently fully understood. It seems that by the mid-seventeenth century there were two different types of these new, larger frigates: one on the Atlantic, perhaps looking like the *patacho* represented in Fernandez's treatise, or showing an even sleeker design; and one in the Mediterranean, that according to a dictionary entry authored by N. Aubin in 1702, was gradually abandoned due to its heavy construction.<sup>35</sup>

This Mediterranean frigate was a long vessel, powered by oars and sails, with the rowers' benches below the weather deck and the hull pierced for the oars. This made it a heavier and harder ship to steer than the normal galley.<sup>36</sup>

By 1678, the Atlantic ship appropriated the name frigate to mean warship for in that year Georges Guillet de Saint George spoke of these vessels as "Lightly framed and not overburdened with timber, agile under sails, and which usually has two decks. This is a well-formed vessel, and of an agreeable mould."<sup>37</sup> No mention is made of Mediterranean

---

<sup>34</sup> Boudriot 1993, 13.

<sup>35</sup> Boudriot 1993, 13.

<sup>36</sup> Boudriot 1993, 13.

<sup>37</sup> Boudriot 1993, 13.



frigates. In 1687, they are defined by Desroches as “Middling vessels which are flush decked and which are not high out of the water.”<sup>38</sup> A few years later, in 1692, the word was already associated with Atlantic seagoing warships in Portugal.<sup>39</sup> In 1702, they were referred to as warships by the English, who have erroneously been credited with inventing the term frigate more or less at the same time the Mediterranean type frigate was abandoned.<sup>40</sup>

By the end of the seventeenth century in Portugal, as in the rest of Europe, frigates were warships fitted with batteries of eight to 60 guns.<sup>41</sup> Smaller than the larger *naus*, they served as coastal patrols and scouts.

From the beginning, these ships’ speed and maneuverability seem to have been their salient characteristics. By 1758, a seabird known for its fast maneuverability and piratical tendencies (as it stole prey caught by other birds while in the air) was called the frigate bird, *fregata aquila*, by Lineus supposedly in honor of those seagoing vessels with similar sailing characteristics (Fig. 10).<sup>42</sup>

---

<sup>38</sup> Boudriot 1993, 13.

<sup>39</sup> Esparteiro 1987, 53.

<sup>40</sup> An entry in a dictionary states that : “The English were the first to give the name of frigates, in the Atlantic, to long vessels armed for war, and which have their gundeck much lower than that of galleons and of ordinary ships” (Boudriot 1993, 13).

<sup>41</sup> Leitão and Lopes 1990, 273; see also Leitão 1978, 20.

<sup>42</sup> Thomson 1964, 325-7; see also Lofgreen 1984, 92.

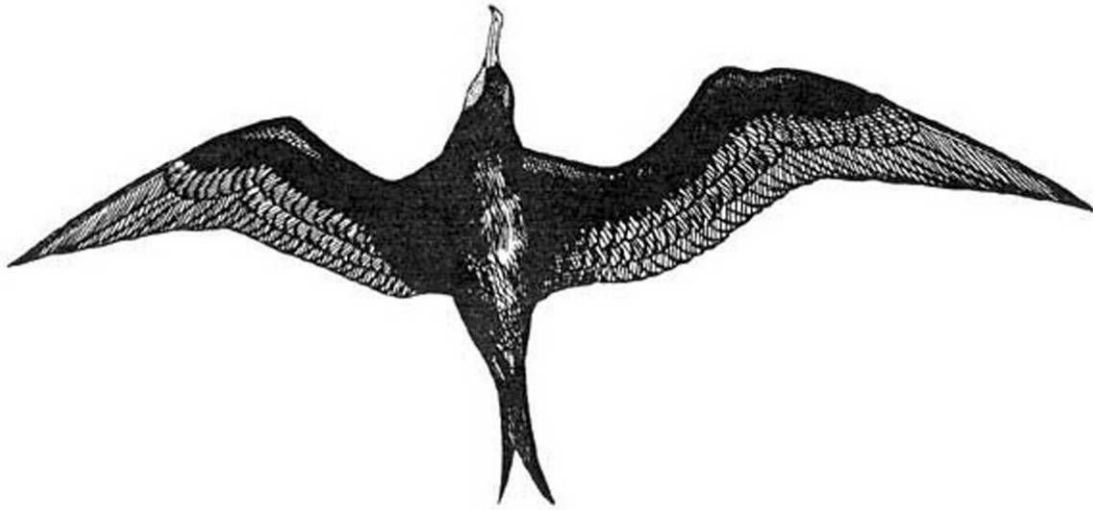

Fig. 10. A representation of *fregata aquila*, common name frigatebird. (From Thomson 1964, 325.)

### The Modern Age frigate

In spite of all the other craft bearing the same name, it is possible that the Modern Age frigate may have originated in the early 1600s when the Spanish built small brigantines to harass Dutch merchants and fishing fleets.<sup>43</sup> These vessels, based upon the design of the *St. Albert*, a ship constructed in Dunkirk of 160 tons and 16 guns, enjoyed great success due to their exceptional ability to wage war. In 1607-8, Don Hurtuño de Urínizar, the new chief official of the Admiralty in Flanders, ordered the construction of a channel-patrolling armada. This armada was built with the main purpose of harassing and preventing the Dutch fleet from reaching their fishing grounds. Eight of these ships

---

<sup>43</sup> Stradling 1992, 33.

were built. However, due to the Truce of Antwerp this squadron was disbanded before committing to battle and ended up in Lisbon. Some of Urínizar's ships were probably already approaching the final design of what would later be called a Dunkirk frigate.<sup>44</sup> In 1618 Urínizar again attempted, but failed, to convince the Spanish crown to build a fleet for the English Channel to be based in Flanders. However, his ideas were put to use later by the *contador* of the Flanders Armada, Diego Pérez de Malvenda, who submitted a budget for the building of 20 ships in the Flemish dockyards; with capacities between 200 to 450 tons, these ships built on the lines of the Dunkirk frigate would be the new English Channel fleet.<sup>45</sup> The purposes of this new fleet were to allow the Spanish to effectively blockade the Dutch from their fisheries and to serve as a privateering force on the Dutch commercial routes in case of hostilities reopening. Although this fleet did not serve in the Thirty Years War (1618-1648), they were used extensively in privateering with great success.<sup>46</sup> By 1618-20, the Dunkirk frigate was used as a construction model by all European powers for the building of ships for privateering (Fig. 11).<sup>47</sup>

---

<sup>44</sup> Stradling 1992, 14-5.

<sup>45</sup> Stradling 1992, 29-30.

<sup>46</sup> The official opening of hostilities between the Spanish and the Dutch was with the Spanish - Dutch war (1621-1648), however the Dutch consider it part of the *Tachtigjarige Oorlog*, Eighty Years War (1566-1648), during the uneasy truce between Spain and Holland (1609-1621), privateering against the Dutch was still authorized and probably escalated in 1618 with the Thirty Years War.

<sup>47</sup> Stradling 1992, 33; Andersan states that the first seventeenth century frigates were produced at Dunkirk (1941, 165).



Fig. 11. Jacob Gerritsz Loef, Witte de With's action with Dunkirkers, 1641. (From Catalogue 1997, 213.)<sup>48</sup>

It was possible that the first Dunkirkers sent to Portugal had some influence in the origin of the seventeenth century naval frigates, but the story of the evolution of the Portuguese frigate has not been studied in depth and it is believed that this type of warship in Portugal during the late seventeenth century was based on French or English models. Fernandez's treatise shows perhaps the frigates' most direct ancestor in the description of a *patacho*, which was translated into English as brigantine (Fig. 12).<sup>49</sup> In an English dictionary dated to 1599, *patacho* was described as a pinnace, a swift ship, and brigantine as a two-masted vessel, square rigged on the fore-mast and fore-and-aft rigged

---

<sup>48</sup> Archibald 1989, 149, 261; see also Preston 1974, 25.

<sup>49</sup> Fernandez 1995, 111.

on the mainmast.<sup>50</sup> However, the *patacho* was also portrayed as a small ship, a Mediterranean oared galley. Perhaps the name brigantine was carried outward into the Atlantic, generally referring to small ships, including the Atlantic *patachos*.

At present, it is tempting to state that *patachos*, pinnaces, and, in the North Atlantic, yachts, are certainly related – at least in the functions performed and in the tonnage ranges in which they were built – to the ancestry of the late seventeenth century frigates.

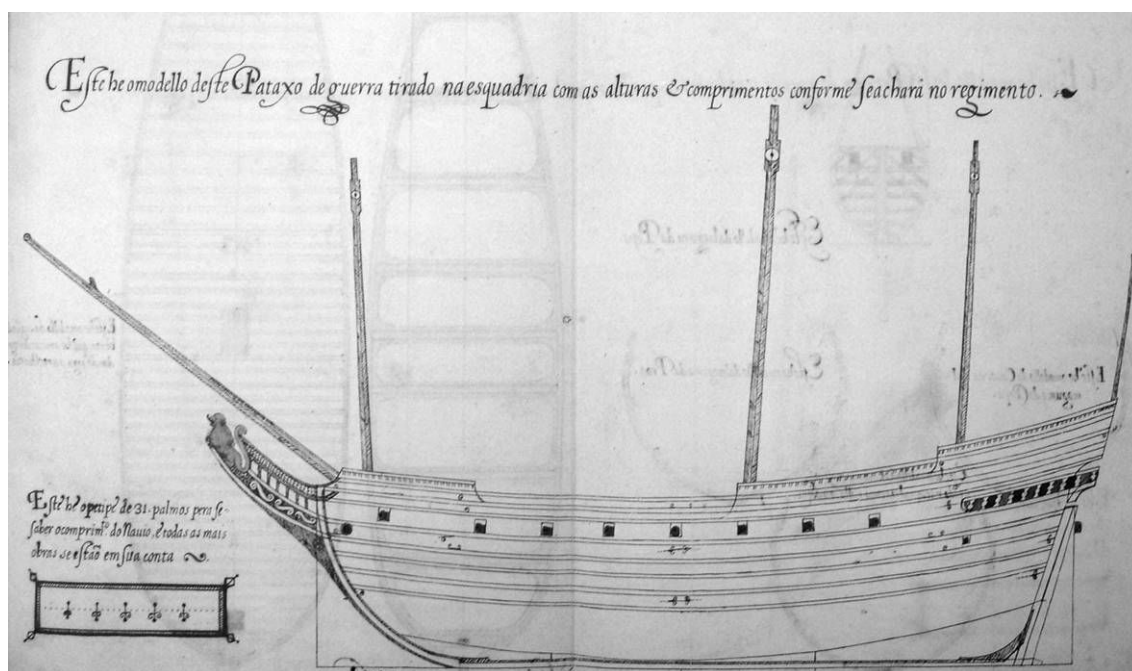

Fig. 12. Portuguese *patacho* of 18 guns. (From Fernandez 1989, 104.)

---

<sup>50</sup> Kemp 1976, 109.

In Portugal *patacho* referred to a swift vessel, but not to a two-masted brigantine, as Fernandez's *patachos* clearly showed a three-masted vessel.<sup>51</sup> In this case, the Dutch *patacho* was the only ship presented by Fernandez that was not Portuguese, and it could be that he included it in his work because of the Dunkirker's impressive record at the Battle of La Marmona in 1614.<sup>52</sup> As in other eras, during the seventeenth century ship types and terminology were very vague and largely interchangeable. Fernandez could have reproduced something close to a Dunkirker and translated its original name as a *patacho*. Moreover, as Dunkirk was part of the Spanish Netherlands in 1616, it was possible that he considered the vessel represented to be a Dutch *patacho*. Despite variation in naming, it was known that these vessels were warships armed with 18 to 26 guns.<sup>53</sup> The early successes of Spain's Flemish fleet could have inspired Fernandez to include this *patacho* in his book (Fig. 13). He specifically called this vessel a warship, reinforcing the possibility that it represents a vessel built along the Dunkirk lines.<sup>54</sup>

---

<sup>51</sup> The projection above the stern in Fernandez drawing resembles a mast, but is in fact a flag staff.

<sup>52</sup> Stradling 1992, 15.

<sup>53</sup> Leitão and Lopes 1990, 398.

<sup>54</sup> Fernandez 1989, 16.

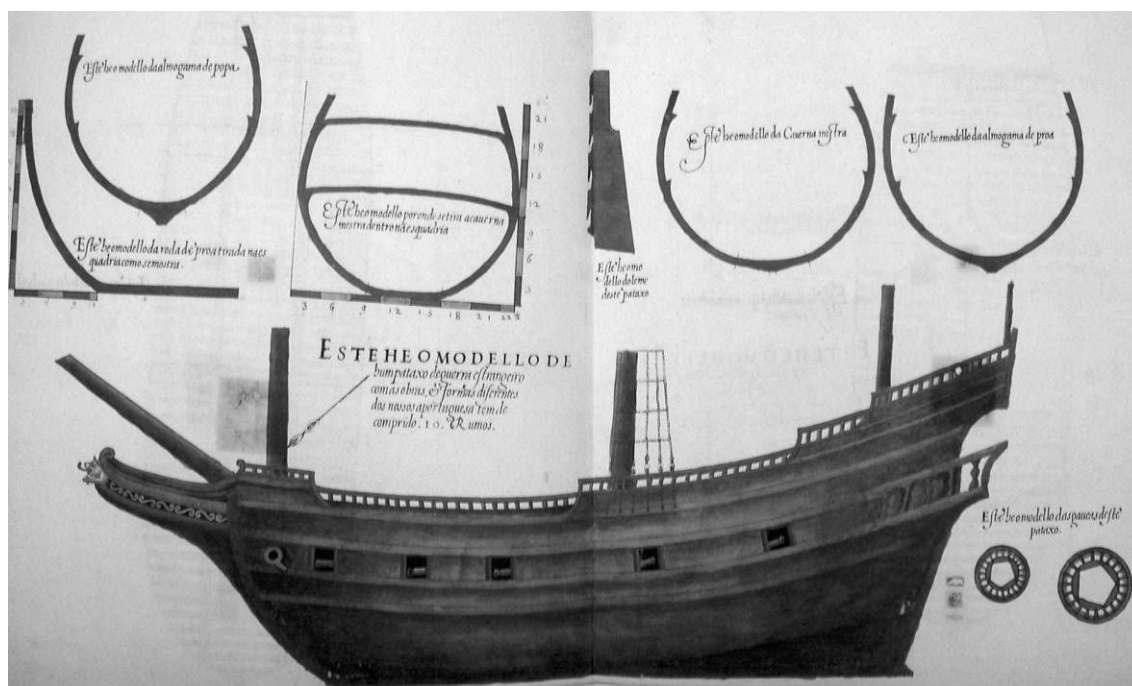

Fig. 13. A Dutch *patacho*, possibly a Dunkirker. (From Fernandez 1989, 133v.)

Assuming that ships with similar functions as the Dunkirkers were named *patachos* in the Iberian Peninsula, or even assuming Fernandez is the only one to designate Dunkirkers as *patachos*, the fact was that treatises and documents before Josep de Veitia Linage's *Norte de la contratación de las Indias Occidentales*, published in 1688 did not call any of the vessels it described a frigate, nor specifically named any vessel as a Dunkirk-built frigate.<sup>55</sup> All ships were mentioned as being galleons or, towards the middle of the century, as just being ships. Dunkirkers seem to have been known to the Habsburg court. A specific reference to a Dunkirk frigate came from the treatise *Livro*

<sup>55</sup> Veitia Linage's book is explained in more detail on chapter VI, 87.

dell' *Arcano del Mare*, authored by the Duke of Northumberland and Earl of Warwick, Robert Dudley, written in 1646 and dedicated to the Habsburg King Ferdinand II.<sup>56</sup> In the forth volume of *Arcano del Mare*, Dudley specifically stated:

Già si portaua la platta dall'Indie Occidentali con certi vascelli lunghi, di vele quadre, nominati fregate, e caminauano bene, ma non erano molto reggenti in Mare ; e di presente si chiamano i vascello da guerra, fregate di Doncherchen in Fiandra : Però l' Autore dà nome di fregata à questa quarta simetria di vascello quadro [...]<sup>57</sup>

He includes in his *Arcano del Mare* two plates of the ship: a diagram of the masterframe and a profile view of a Dunkirk frigate (Fig. 14).<sup>58</sup>

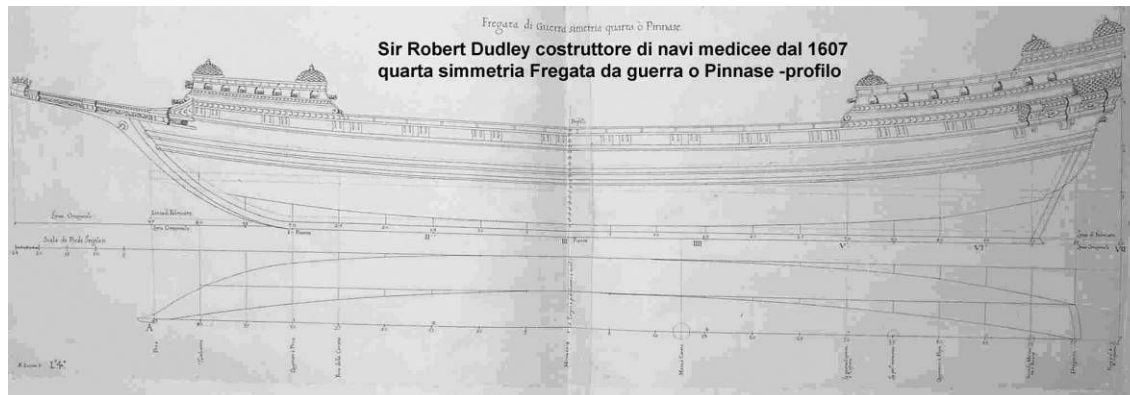

Fig. 14. Robert Dudley's Dunkirk-built ship plate. (After Dudleo 1646.)

<sup>56</sup> Although Dudley was of English nationality, he wrote the original version of the book in Italian (Dudleo 1646).

<sup>57</sup> The silver of the West Indies was transported in certain long vessels with square sails, called frigates, speedy but not very seaworthy in open sea, and at present war vessels are called frigates of Dunkirk in Flanders. However the author calls frigates this fourth symmetry of square rigged vessel [...].(Dudleo 1646, 22.)

<sup>58</sup> Dudleo 1646, fig.12-3.



On the other hand, on the northern shores of France that stood between Spain and the Low Countries, the French attributed the origin of the frigate to the *Double Chaloupe* or *Shallop*, a large, undecked vessel armed with a few swivel guns. It seems that these vessels developed into the frigate by the addition of a flush deck, a small castle fore and aft, and mounted cannons. In 1669, the French referred to these ships as *fregates legeres* and one year later the French crown were already defining specifications for them (Fig. 15):

Light frigates of eight to 16 guns shall have a small forecastle to protect the galley fires and one aft to protect the officers quarters, running as far aft and forward as may be appropriate.<sup>59</sup>

The similarities in design between the French light frigates and the Spanish-Portuguese *patachos* suggests similar functions in a naval fleet and perhaps similar origins in conception and design (Fig. 13 and Fig. 15).

The evolution of French ships, including the light frigates, had much to do with the Shipbuilder's Council, a French organization created in 1671 to study naval vessels. Instructed to collect all measures of individual ships and shipbuilding techniques, they were supposed to inspect, and suggest improvements to, shipbuilder's plans of naval vessels before commencement of their construction. The extent of this information gathering was such that captains were instructed to keep two ship journals; one for the

---

<sup>59</sup> Boudriot 1993, 52.

ship, and the other for the Shipbuilder's Council, containing a record of all information concerning the handling of the ship, any problems it encountered, and suggestions for the improvement of its design.<sup>60</sup> This procedure was instrumental in the evolution of the frigate as a ship type.

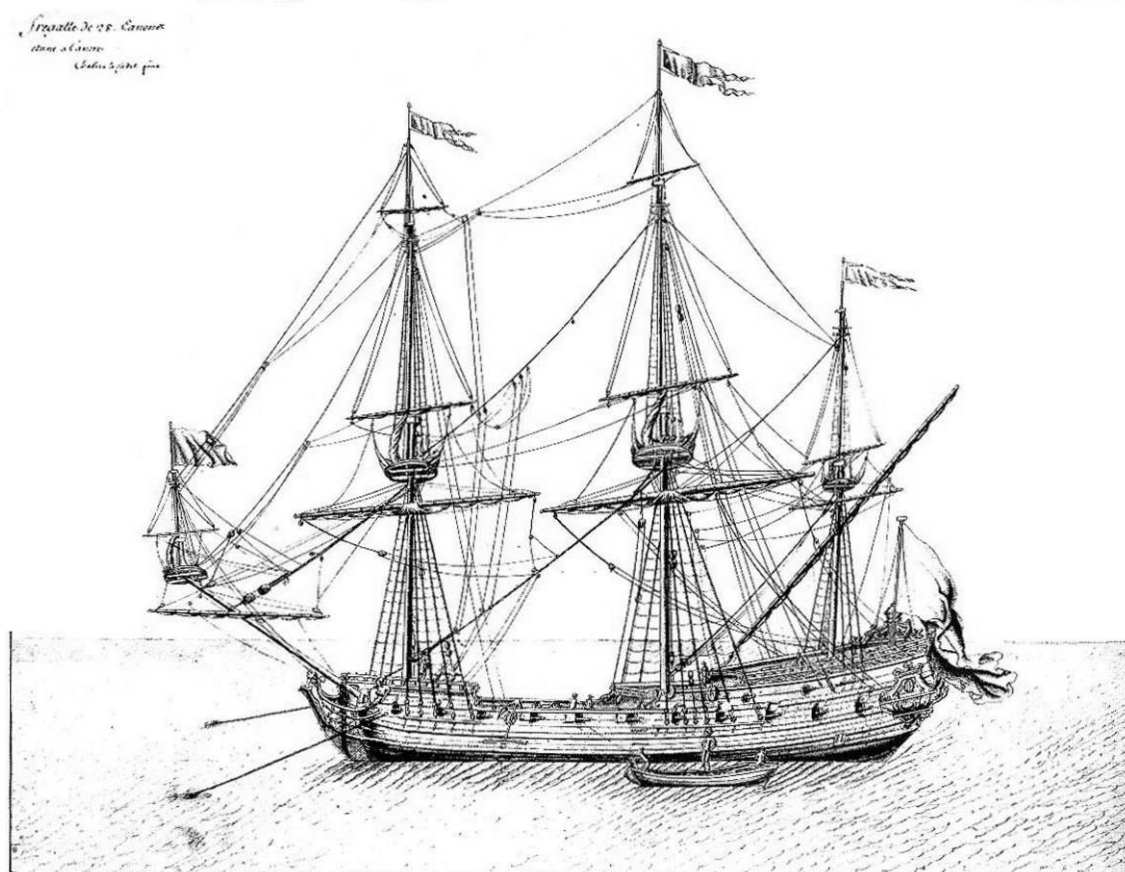

Fig. 15. A French light frigate. (From Boudriot 1993, 54.)

---

<sup>60</sup> Boudriot 1993, 36-7; see also Boudriot 1990.

By 1736 frigates were established in France as warships and had their own system of classification.<sup>61</sup> Soon afterwards, by the mid-eighteenth century, French frigates and ‘light frigates’ had evolved into the modern frigate.<sup>62</sup> The light frigates that preceded the later frigate were renamed *corvettes* (the English term is sloops of war), having only one tier of guns.<sup>63</sup>

Despite their reputation for having invented the term frigate, the English seem to have been reactive in the process of creating this type of naval vessel. During the seventeenth century it appears that English ships conducted privateering on a much smaller scale than that of the French and Spanish.<sup>64</sup>

It took a considerable length of time, between 1588 to 1649, for the English to create a ship capable of responding to the Dunkirk privateers, despite the fact that the Dunkirkers harassed both Dutch and English merchant routes, and with alarming results, they never seem to have been a major concern for the English.<sup>65</sup> As the Galleons of the Royal Navy were too sluggish to keep up with their faster and sleeker adversaries, the response of the English Navy was to acquire Dunkirkers of its own and incorporate them into the fleet as early as 1612.<sup>66</sup> In 1620, William Burrel proposed a ship design to counter these privateers, but the king’s conservatism and the financial difficulties endured by the realm

---

<sup>61</sup> Boudriot 1993, 13.

<sup>62</sup> Boudriot 1993, 12.

<sup>63</sup> Boudriot 1993, 52.

<sup>64</sup> Meyer 1981, 270; see also Timeweel 1979.

<sup>65</sup> Baumber 1971, 388; see also Kepler 1973, 219; see also Timewell 1979, 204.

<sup>66</sup> Winfield 1997, 7; see also Lavery 1983, 18.

seemed to have constrained any major redesign of English ships. As a result, only a few frigate-like types were built, and those built were not equals to the Dunkirkers in speed and maneuverability.<sup>67</sup> In October 1636 the Royal Navy began its own construction program, after the capture of the Dunkirker *Nicodemus*.<sup>68</sup> The capabilities of *Nicodemus* impressed the Navy such that in 1637 two ships, *Expedition* and *Providence*, were built with some frigate characteristics. Unable to replicate the excellence of the *Nicodemus*, the Royal Navy continued to prefer to buy Dunkirkers and in 1643 more were purchased and incorporated.<sup>69</sup> Deprived of most of the navy, the Dunkirker's fame convinced the king to hire several for commercial raiding and supply during the English Civil War (1642-1649).<sup>70</sup> The first true English frigate is considered to have been the privateer *Constant Warwick*, purchased from Earl of Warwick on 20 January 1649, and was likely responsible for the misplaced credit given to the English for the invention of the frigate. In any case, England's frigate construction program had begun and would continue for the next two centuries. During the Commonwealth, beginning in 1649, the number of frigates in the English navy increased drastically. Those on active duty were used extensively in the Anglo-Dutch Wars.<sup>71</sup>

Initially the Dunkirkers and Dunkirk-built frigates only had one gun deck and a quarterdeck with small culverins, but by 1647 the quarterdeck extended into a full deck

---

<sup>67</sup> Winfield 1997, 7-8.

<sup>68</sup> Winfield 1997, 8.

<sup>69</sup> Winfield 1997, 8.

<sup>70</sup> Lavery 1983, 18; see also Ohlmeyer 1990; see also Oppenheim 1894.

<sup>71</sup> Winfield 1997, 12-7; see also Lavery 1983, 19; see also Gardiner 1992.

and by 1650 a forecastle and chaser guns were added; these ships became the standard of the British eighteenth century fourth-rates. Armed with up to 48 or 50 guns, these strong ships were descendants of the Dunkirk frigate (Fig. 16).<sup>72</sup>

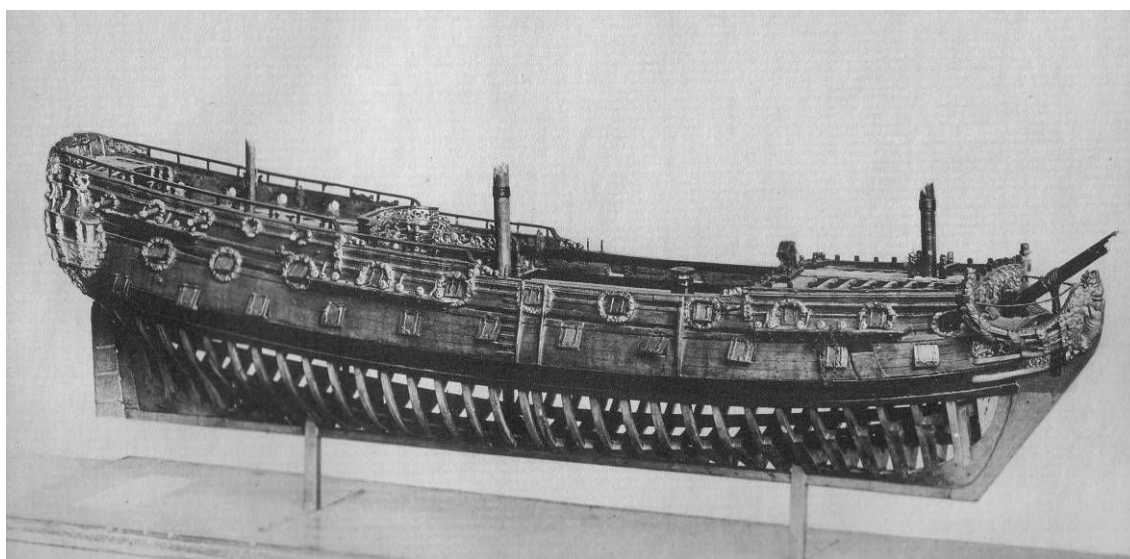

Fig. 16. Seventeenth-century model of an English 50-gun ship. (From Culver 1954, 24.)

### Ship classification

Warship rating in the seventeenth century could be discussed in terms of the development of the line of battle, and the ship of the line must therefore be mentioned. The beginnings of the line of battle are obscure, but it is accepted that it was first used in

---

<sup>72</sup> Winfield 1997, 7.

a systematic fashion during the first Anglo-Dutch War.<sup>73</sup> The first battles of the Anglo-Dutch War showed the need for a new tactic that would maximize the use of the firepower of broadside-mounted guns. The line of battle, attempted as an experiment at the Battle of Gabbard Bank (2-3 June 1653) provided definitive proof of the effectiveness of this new tactic.<sup>74</sup> Line of battle tactics placed the vessels of a fleet in a straight line that would converge upon the enemy and offer a continuous row of broadsides against the foe without any friendly ship masking one another.<sup>75</sup> It became the standard naval tactic until the nineteenth century.<sup>76</sup>

The ship of the line was, in its basic definition, a ship capable of forming part of a line of battle and able to sustain damage from similarly-sized enemy ships and respond effectively.<sup>77</sup> As the ship of the line had to maintain formation and endure enemy fire during a battle at very close quarters, it became evident that only the ships that were strongly built and well armed could be used in that capacity.<sup>78</sup> As a result, warships were gradually designed, built, armed and ranked to fit the new requirements and classed according to where they belonged in the line of battle. First rates, the biggest and most well armed, were expected to be at the lead and begin the action; fifth and sixth rates, the smallest rated vessels, were not expected to serve directly in the line, but instead acted as signal ships, reserves, or scouts.

---

<sup>73</sup> Lavery 1883, 26; see also Woodman 1997, 79-80.

<sup>74</sup> Tunstall 1990, 19-21.

<sup>75</sup> Lavery 1983, 26-7

<sup>76</sup> Woodman 1997, 80, Lavery 1983, 27.

<sup>77</sup> Lavery 1883, 8

<sup>78</sup> Lavery 1983, 27.

The first known European mention of frigates in the naval classification system was in the French regulation of 1669, which implicitly divided ships by number of guns in five rates, and included the frigate.<sup>79</sup>

Only a few months later the lowest rate of the French ship-of-the-line, or *navire de ligne*, was specifically called a frigate in a regulation dated 4 July 1670. This regulation defined the rates not only in terms of guns, as in the previous text, but also in terms of the number of gun decks and castles (Table 1).

The French Crown Great Edict of 1689 included a new classification where the type and amount of ordnance was also considered, together with some shipbuilding specifications. The Great Edict was composed of twenty-three books and dealt with almost everything related to the French Royal Navy. At a later date, the French also divided their warships into two orders, First order ships mounted 12-pound guns on their gun deck; ships of the second order mounted 8-pound guns on the gun deck.

---

<sup>79</sup> Boudriot 1993, 16.

**Table 1. 1670 French ship classification.**

<b>Rate</b>	<b>Guns</b>	<b>Deck and Accommodations</b>
First Rate	70 to 80 guns	Three full decks; stern and fore castle
Second Rate	56 to 70 Guns	Three full decks; stern and fore castle
Third Rates	40 to 50 guns	Two full decks; stern and fore castle
Fourth Rate	30 to 40 Guns	Two running decks; stern and fore castle
Fifth Rate	18 to 28 Guns	Two running decks; stern castle only
Light - Frigate	8 to 16 guns	One deck; larger ones one forecastle

The first seventeenth century English classification came from the Commission of 1618, which divided warships into four classes: Royal Ships of 800 tons and larger, Great Ships of 600 to 800 tons, Middling Ships of 450 tons, and Small Ships and Pinnaces.<sup>80</sup>

The English custom was to name a class after the first ship built with the characteristics that defined the class. This tradition made the English classification system confusing. Frigates in the 1650s seem to have been classified as third and fourth rates. However,

---

<sup>80</sup> Lavery 1983, 14.



their classes were categorized under length of keel and not armament. For instance, third rates were designated Great Frigates of 120 ft; the *Speaker* class of 116 ft was named after the ship *Speaker* built in 1650. Fourth rates were divided into the 110 ft class and the 100 ft class.<sup>81</sup> Although the term frigate did not appear to designate a standard type of vessel at this time, it became interchangeable with the Great Ship class terminology.<sup>82</sup> In the mid seventeenth century some of the vessels built by English shipyards included in the Great Ship classification were built more narrowly than the actual model of a Great Ship, and would be considered true frigates by today's standards.

The English Establishments of 1666, 1677, and 1685, referred again to the number of ordnance for specific ships and not to classifications.<sup>83</sup> *Gloria Britannica* a book, printed for Thomas Howkins, enumerating the existing ships of the Royal Navy as well as the table of wages does not mention frigates in its 1689 version.<sup>84</sup> It divided the ship's listing by rates from first to sixth rate and then on Hulks, Fireships, Yachts, Ketches, Hoyes, and Sloops. *Constant Warwick*, considered the first English frigate, was classified in *Gloria Britannica* as a fourth-rate. *Gloria Britannica* indicated the number of men necessary to handle each of the ships in war and in peace time, as well as the guns to be onboard during these two periods. The following table showed the more significant ship classes and the minimum and maximum men and gun complements required for each one in wartime (Table 2).

---

<sup>81</sup> Lavery 1983, 20.

<sup>82</sup> Lavery 1983, 21.

<sup>83</sup> Winfield 1997, 10.

<sup>84</sup> Howkins 1689, 1-9.

**Table 2. *Gloria Britannica*'s 1689 listing.**

<b>Rate</b>	<b>Guns</b>	<b>Men</b>	<b>Length of Keel</b>
First Rate	90 - 100	520 - 710	125 - 146
Second Rate	64 - 90	335 - 580	116 - 142
Third Rate	60 - 70	270 - 380	108 - 138
Fourth Rate	30 - 54	150 - 240	87 - 109
Fifth Rate	28 - 38	105 - 115	72 - 96
Sixth Rate	4 - 18	25 - 70	38 - 75
Yachts	4 - 8	4 - 20	30 - 66
Sloops	10 - 61	10	4

A 1696 document that seems to be a partial compilation of a revised edition of the *Gloria Britannica* still does not show frigates as a class.<sup>85</sup> However, this revised edition is incomplete and lacks the pages with the tables for the first to fifth rate ships.

Nevertheless, the English began to standardize their ships in the late seventeenth century.

The new system became known as the Establishment of Dimensions. As the French had already done in 1673, the English Establishment of 1706 laid down the principal dimensions for each class of ship. Although this first 1706 Establishment defined the dimensions more broadly, the following version, the Establishment of 1719, required a

---

<sup>85</sup> Howkins 1696, 6-9.

more rigid set of ship dimensions than its French counterpart did in 1689.<sup>86</sup> By the middle of the eighteenth century, the English had developed the following classification (Table 3):

**Table 3. English ship classification.**

<b>Rate</b>	<b>Guns</b>
First Rate	100 guns
Second Rate	90 Guns
Third Rates	64 to 80 guns
Fourth Rate	50 to 60 Guns
Fifth Rate	32 to 44 Guns
Sixth Rate	20 to 28 guns

The Portuguese only clearly defined the line separating merchant vessels from war vessels at the end of the seventeenth century.<sup>87</sup> However, they quickly adapted to the new naval circumstances, because at the same time they differentiated their warships, including frigates. In a set of instructions sent to Goa in 1692, ships are specifically called frigates. These new ships, which replaced the galleon that failed in its role of war

---

<sup>86</sup> National Maritime Museum (2004, 1 November. *Ship of War 1650 - 1815*. [http://www.nmm.ac.uk/site/request/setTemplate:singlecontent/contentTypeA/conWebDoc/contentId/14112/set\\_paginate/No/navId/005001001](http://www.nmm.ac.uk/site/request/setTemplate:singlecontent/contentTypeA/conWebDoc/contentId/14112/set_paginate/No/navId/005001001)); see also Boudriot 1993, 18.

<sup>87</sup> Monteiro, 1996, 9.

vessel, followed the French and English model of building and were probably classified in a manner similar to the French system.<sup>88</sup>

In summation, despite all of the questions surrounding the evolution of the frigate and the elusiveness of the term frigate, in general terms these vessels were smaller, built for speed, and less expensive than regular warships; but they were also as well armed as any other ships of their size. These characteristics allowed them to assume different functions than those attributed to the regular ships of the line. They were employed as escorts for convoys and for policing coastal waters, they served as corsair vessels and sometimes as well-armed supply vessels.<sup>89</sup> In fleets of warships, frigates' primary role was to act as scouts and fast couriers. By the mid eighteenth century, although they kept their original functions, they would evolve into potent naval vessels in their own right.<sup>90</sup> These qualities and functions embodied in *Santo Antonio de Tanná*, a Portuguese frigate sunk in 1697 in Mombasa, Kenya.<sup>91</sup>

---

<sup>88</sup> Monteiro 1993, 29; see also Monteiro 1996, 9.

<sup>89</sup> Pioffre 1994, 14.

<sup>90</sup> Merino and Meyer 1986, 25.

<sup>91</sup> Esparteiro 1987, 56-9.

CHAPTER IV  
HISTORY OF *SANTO ANTONIO DE TANNÁ*

*Santo Antonio de Tanná's* story starts in India, as many other vessels, in the last decades of the seventeenth century.<sup>92</sup> Built by an order of the Portuguese Crown issued to Dom Antonio Sottomayor, captain of Bassein, in February 1678, this ship was a 42-gun frigate scheduled to be ready by the end of the year. Bassein was an important shipyard, located 50 km north of Bombay (today Mumbai).

Funding difficulties delayed construction of the frigate, but the hull was eventually launched in December 1680.<sup>93</sup> By then Bassein had a new captain, Dom Vasco Luis Coutinho, who brought with him from Portugal a new master shipbuilder named Manuel da Costa. Although Manuel da Costa is credited with actually building the frigate, it is likely that he merely supervised the completion as the construction of the ship commenced before his arrival.<sup>94</sup>

Following its launch at the shipyard, the hull, was then towed from Bassein by another frigate, also named *Santo Antonio*, to be completed in Goa 630 km south of Bassein. The

---

<sup>92</sup> Several shipyards, like Goa and Bassain would regularly produce ships for usage in the East Indies and to the India Route, being very common the shipbuilding of Portuguese ships in Portuguese India.

<sup>93</sup> Blot and Blot 1984, 5.

<sup>94</sup> Blot and Blot 1984, 5.

upper works, the masts and rigging were added in the Goa shipyards following the crown's instructions (Fig. 17).<sup>95</sup>

By 1681 the ship was part of the viceroyalty fleet, and baptized *Santo Antonio de Tanná*.<sup>96</sup> This frigate was a welcome addition to a fleet composed of 11 large ships of war and several smaller ships. Few records of its career have been located, however, at least until its demise in 1696. One document dated 22 January 1689, states that the ship was ordered to transport bronze artillery from Diu to Goa.<sup>97</sup> It is known that *Santo Antonio de Tanná* successfully completed at least one round-trip voyage from Goa to Lisbon.<sup>98</sup> In January 1693 it was ordered to load 424 barrels of saltpeter and proceed to Lisbon under the command of Captain Luis da Costa Figueira.<sup>99</sup> It seems that this voyage ended in the harbor of Vigo on the northern coast of Spain instead of Lisbon, and that the ship stayed in this Spanish port for several months for reasons unknown.<sup>100</sup> It is known that *Santo Antonio de Tanná* was in Lisbon by the end of 1694 and that it stayed there until April 1696.<sup>101</sup> On the 6 April 1696, *Santo Antonio de Tanná* left for India under the command of Captain Henrique de Figueiredo de Alarcão.<sup>102</sup> After visiting Mozambique it proceeded to Goa.<sup>103</sup>

---

<sup>95</sup> Pona 1890, 218.

<sup>96</sup> Blot and Blot 1984, 6.

<sup>97</sup> Blot and Blot 1984, 42; see also Esparteiro 1987, 56.

<sup>98</sup> Boxer 1984, 41.

<sup>99</sup> Blot and Blot 1984, 42-3; see also Esparteiro 1987, 56.

<sup>100</sup> Blot and Blot 1984, 43-4.

<sup>101</sup> Sassoon 1981, 114.

<sup>102</sup> Esparteiro 1987, 56.

<sup>103</sup> Sassoon 1981, 129.

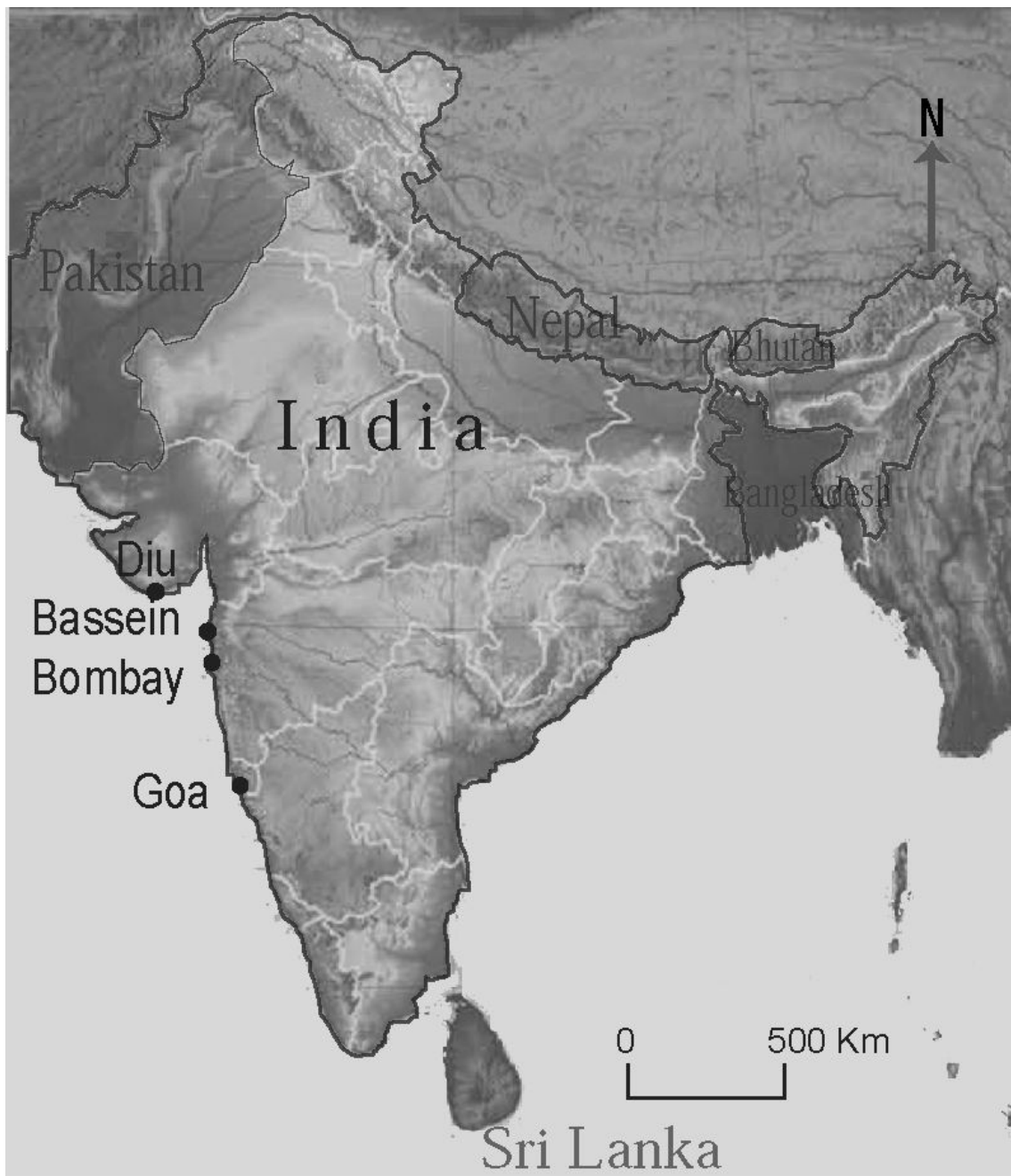

Fig. 17. Diu, Bassein, Bombay and Goa.

In November 1696 *Santo Antonio de Tanná* sailed to Mombasa as the flagship of a squadron under the command of Captain Domingos Pereira de Gusman to deliver supplies and reinforcements to the besieged Fort *São Jesus*. The squadron was composed of *Santo Antonio de Tanná* and another frigate, *Nossa Senhora do Vale*, together with a number of small vessels.<sup>104</sup>

Fort *São Jesus* was a post of strategic importance to the Portuguese and had fallen under assault by Omani forces, an emergent maritime empire from the Arabic Province.<sup>105</sup>

The Portuguese squadron arrived at Mombasa on Christmas Day 1696 and immediately started to disembark troops and supplies to the fort which was reputedly about to fall.<sup>106</sup>

On 14 January 1697, however, the ship lost some anchors and was forced to cruise back and forth while the remaining supplies were unloaded and transported to the fort on small boats.

Accomplishing its mission, *Santo Antonio de Tanná* departed for Mozambique on 25 January.<sup>107</sup> The following months were uneventful, except for a small problem in April when the ship was caught by a hurricane that struck Mozambique and lost its rudder.<sup>108</sup>

On 28 August 1697, General Sampaio de Melo, appointed governor of Mozambique, received distressing news from Fort *São Jesus*. The fort was still under attack by Omani

---

<sup>104</sup> Blot and Blot 1984, 45.

<sup>105</sup> See Chapter II for more information on Omani; see also Chapter V for Fort *São Jesus*.

<sup>106</sup> Kirkman 1975, 4.

<sup>107</sup> Piercy 1979, 308.

<sup>108</sup> Piercy 1979, 308.



forces. The Portuguese garrison had died of disease and the fort was threatened by the Omani besiegers. The Prince of *Dau*, a local prince loyal to Portugal and commanding both Arab and African forces, was defending the fort. The general armed a small squadron in haste and led a relief mission to the beleaguered fortress. *Santo Antonio de Tanná* again sailed as the flagship. As in the first relief mission of 1696, Sampaio de Melo had orders to avoid endangering his ships as *Santo Antonio de Tanná* was part of a much diminished Indian fleet that by this time was composed of only five frigates and 17 smaller vessels.

After a stop at Zanzibar to take on more troops, the squadron sailed to Mombasa and was in sight of the fortress by 15 September 1697 (Fig. 18). Mooring in front of the *São Jesus*, the ship came within range of Omani artillery and lost several anchor cables. Nevertheless, it continued to unload its cargo until 20 October when, during an Omani attack, *Santo Antonio de Tanná* lost its last mooring lines. It is unknown if the ship lost its lines due to gunfire, sabotage, or simply because of rotting, but it is certain that the ship ran aground near the Muslim battery. Intense fighting continued as the Omani army tried to take the ship, but a relief party from the fortress captured a small palisade overlooking the site of the battle and forced an enemy retreat. On the following tide the ship was towed closer to the fort. Upon assessing the damage and judging the damage to the hull too severe to allow the ship to be put afloat again, it was decided by a council of officers and the General to salvage and scuttle *Santo Antonio de Tanná*. It is not clear if they carried their intention or if the ship sank first. One of the contemporary manuscript accounts of the loss of the fort states “the weight bearing on the prow caused it to heel

over and the frigate capsized and sank below the reef ...”.<sup>109</sup> The amount of artifacts located during the excavation does point to an accidental sinking while the salvage operation was under way.

The fighting at the fort continued, but the Portuguese forces were overwhelmed and Fort *São Jesus* surrendered on December 13, 1698.

According to a letter written in December 1698 by Viceroy Antonio Luis Gonçalvez da Camara Coutinho, Count of Vila-Verde (1697 -1701), *Santo Antonio de Tanná* sank with 50 bronze guns aboard.<sup>110</sup> It is known that the Portuguese forces salvaged the ship before scuttling and they certainly had time to remove at least part of the artillery. It is not known if *Santo Antonio de Tanná* was refitted in order to be able to carry 50 guns or what the sizes of those guns may have been. Blot and Blot state that the ship was probably refitted at Goa after the first relief expedition to *São Jesus* in 1696.<sup>111</sup>

---

<sup>109</sup> Kirkman 1979, 308; see also Sassoon 1982, 106.

<sup>110</sup> Blot and Blot 1984, 54.

<sup>111</sup> Blot and Blot 1984, 47.



Fig. 18. Mozambique, Zanzibar and Mombasa.

The shipwreck was discovered in the 1960s by two skin divers, Conway Plough and Peter Philips, at a depth of 15 meters in the old Mombassa harbor.<sup>112</sup> It was excavated from 1976 to 1980 by a joint team from the Institute of Nautical Archaeology and the Fort Jesus Museum. Although the hull of *Santo Antonio de Tanná* was never raised from the bottom of the harbor, the excavation team recovered more than 15,000 artifacts and was successful in establishing a picture of Portuguese seventeenth century maritime life.<sup>113</sup>

The hull remains were partially recorded. A full photographic record of the *in situ* timbers was carried out, a preliminary site plan was drawn, and a number of cross-section profiles were taken of the inner surface of the hull. The ship remains still rest where the frigate was lost in 1697, buried under several meters of sand.

To better understand the geopolitical and military importance of Fort *São Jesus*, known today as the Fort Jesus Museum, and the reasons why the Portuguese risked losing *Santo Antonio de Tanná* in the fort's defense, the next chapter presents the history of the fort, which had an decisive role in *Santo Antonio de Tanná*'s history.

---

<sup>112</sup> Piercy 1977, 331.

<sup>113</sup> Piercy 1998 ; see also Sasson 1978, 1979, 1980,1982.

CHAPTER V  
HISTORY OF THE FORT *SÃO JESUS* IN MOMBASA

### Background

The Portuguese presence along the Swahili coast, located on the south-east area of the African continent, was overshadowed by a mythical Portuguese version of *El Dorado*, the Empire of *Monomotapa* (Fig. 19).<sup>114</sup> When the first ships sent by the king of Portugal arrived on the east coast of Africa in search of a passage to the Indian subcontinent and its rich markets in the last years of the fifteenth century, one of their objectives was to discover and explore the *Monomotapa* Empire, a region expected to provide easy access to gold and slaves.<sup>115</sup> The *Monomotapa* Empire was believed to stretch from Sofala to Quiloa, the area today occupied by the Republic of Mozambique, and the crown invested heavily in the occupation and defense of a number of key areas of that region, which were expected to yield the best return on the investments made. The protection of the less profitable coastal regions on the east African coast was left to a few small garrisons and patrol boats.

---

<sup>114</sup> Boxer and Azevedo 1960, 18; see also Pinto 2002, 33; see also Ames 1998.

<sup>115</sup> Subrahmanyam 1993, 173-4.



Fig. 19. The *Monomotapa* empire by Joao Texeira 1630. (From Axelson 1960, pl. 4.)

It was not until the political unrest felt between 1585 and 1589 that the Portuguese crown decided to commit the considerable resources needed to fortify its positions on the Swahili coast. Attention to this issue was brought about by the Omani invasion, which triggered a local uprising and widespread support of the Omani forces by most local cities, except for the port city of Malindi.<sup>116</sup> Decades of Portuguese intermittent occupation must have encouraged the local population to support the invading army,

<sup>116</sup> Lima 1946, 88.

perhaps wanting to avenge the abuses of Portuguese soldiers on the local populations. Often times, idle soldiers left their assigned garrisons to live among the local villages. Far away from their homeland and not always paid in time, discipline was soft, and there is evidence that soldiers supported themselves through fraudulent deals, coercion, and even theft from the locals.

Thus the Portuguese presence was threatened by the hostility of the local populations and it was known that rebellion in the eastern African continent could compromise the safety of the India route. A two year round-trip voyage from Lisbon to Goa and back, the India route had started in the sixteenth century after Vasco da Gama had discovered the maritime passage to the Indian subcontinent. This route had supplied Lisbon with pepper, white cotton cloth, spices, drugs, and countless exotic products that made the fortune of the country in the first half of the sixteenth century and transformed Lisbon into a cosmopolitan world centre. Changing social conditions later in the century impoverished Portugal, and the death of king Sebastião in 1578 during a badly planned attempt to invade the northern coast of Africa left no heir to the crown. The Spanish emperor Philip II took possession of the Portuguese crown in 1580, and Spain maintained dominion over Portugal until 1640. In the meantime the Portuguese *naus* kept leaving Lisbon to Goa every year in March or April, engaging in a trip around Africa that lasted about six months. Near the eastern African coast these ships were close to land and sometimes stopped for victualling or simply to avoid monsoons when delays made it impossible to cross the Indian Ocean. Any hostile force that established itself in that area could enjoy good opportunities for privateering.

In 1587 the king felt compelled to protect the eastern coast of Africa and sent a punitive expedition led by Martin Afonso de Mello to help re-establish Portuguese power in the area. The ease in which the Omani rulers could potentially subvert and take possession of the region led to a recommendation to the Spanish king to establish a more permanent series of fortifications. However, no action followed this advice. A second invasion by the Omani in 1588, which quickly conquered the area, exposed the fragility of the Portuguese presence in these waters. With the *Rota da Índia* again in danger, in 1589 the Portuguese planned and executed a second punitive expedition. The success of this expedition was greatly helped by a simultaneous attack by African tribes led by a local leader named Zami. The leader of the Omani forces surrendered to the Portuguese with his surviving men to avoid capture by Zami's forces who were believed to perform cannibalistic rituals on their defeated enemies.<sup>117</sup> Later the Portuguese also captured the local leaders who had revolted against the Portuguese rule. After this second Omani invasion there was no doubt that fortification of the area was required to control two of the most important cities in the region, Pate and Lamu, and that the best location for it was Mombasa, a small coastal city (Fig. 20).<sup>118</sup>

---

<sup>117</sup> Lima 1946, 89.

<sup>118</sup> Chittick 1969, 390.



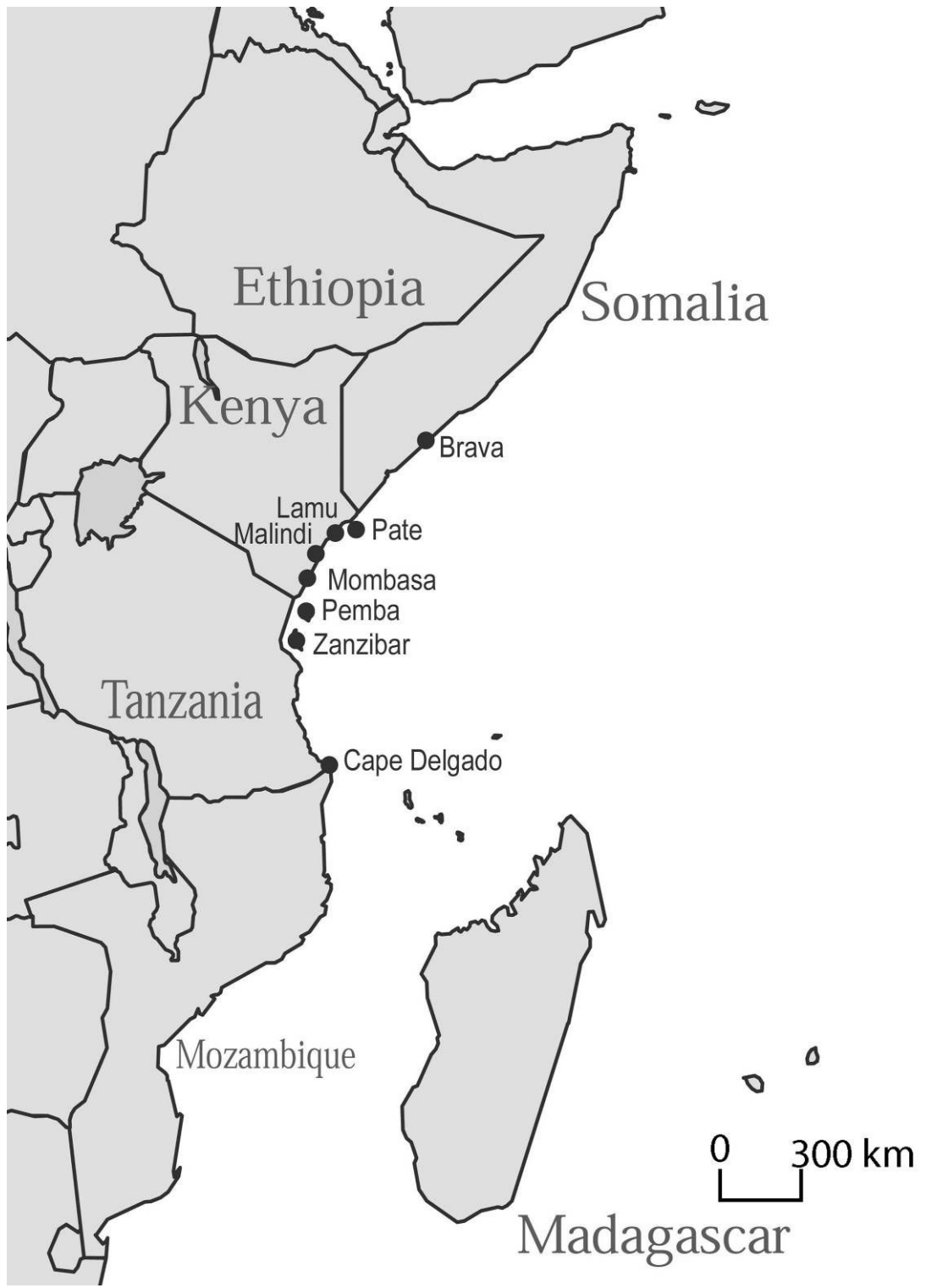

Fig. 20. The area of the fort's influence.

Mombasa was located on an island and its topography allowed an easy defense from both sea and land, while the depth of the harbor permitted any vessel, regardless of its size, to dock next to the planned fortification site. The Iberian crown commissioned plans from an Italian architect for the building of a fort in the best port of the area.<sup>119</sup>

The architect

Giovanni Batista Cairato was the chief architect of the East Indies. As such, he designed the project and supervised the construction of the fort, which was named *São Jesus*. The fort itself was built under the direction of a Portuguese master mason, Gaspar Rodrigues.

Like many architects in the Spanish empire, João Baptista Cairato (as he was known in Portugal) was an Italian with a renowned reputation and was entrusted with the supervision of all the fortifications in the Portuguese East Indies. Cairato is believed to have been Milanese, or at least became internationally known for his architecture during his time in Milan.<sup>120</sup> Even before he reached his thirties Cairato was in charge of the construction of very important fortifications in Malta. In 1563 he gained the title of Engineer of the Community of Milan and by then was known as an architect of some repute in Italy. By 1565 he had written a book on the fortifications of Malta. His career then took him to Spain in 1577. In 1581 Cairato was responsible for the study of the fortifications of the recently acquired country of Portugal under the orders of the Viceroy Marquis of Santa Cruz.

---

<sup>119</sup> Kirkman 1975, 1.

<sup>120</sup> Boxer and Azevedo 1960, 92.

In 1583 Cairato was sent to the East Indies as Chief Architect to “superintend all problems of the Portuguese fortifications.”<sup>121</sup> His achievements were so great that after he requested to return to Europe in 1596, his resignation would not be accepted until a worthy successor could be named. As a result Cairato spent the last months of his life in the East Indies. He died in 1596, after thirteen years of service in the Indian Ocean, awaiting for permission to return to Europe.

### Fort design

Fort *São Jesus*, Giovanni Cairato’s final work, began on 11 April 1593 (Fig. 21).

Built from original plans by Cairato, the fortress remained largely untouched until the end of the Portuguese occupation. Modifications made during the first years of use seem to consist of only a few small improvements.

Employing the Italian style of fortification of its time and carefully studying the terrain, Cairato chose a simple design for the fort with a rectangular plan and a bastion on each of its four corners (Fig. 22).

---

<sup>121</sup> Boxer and Azevedo 1960, 93.

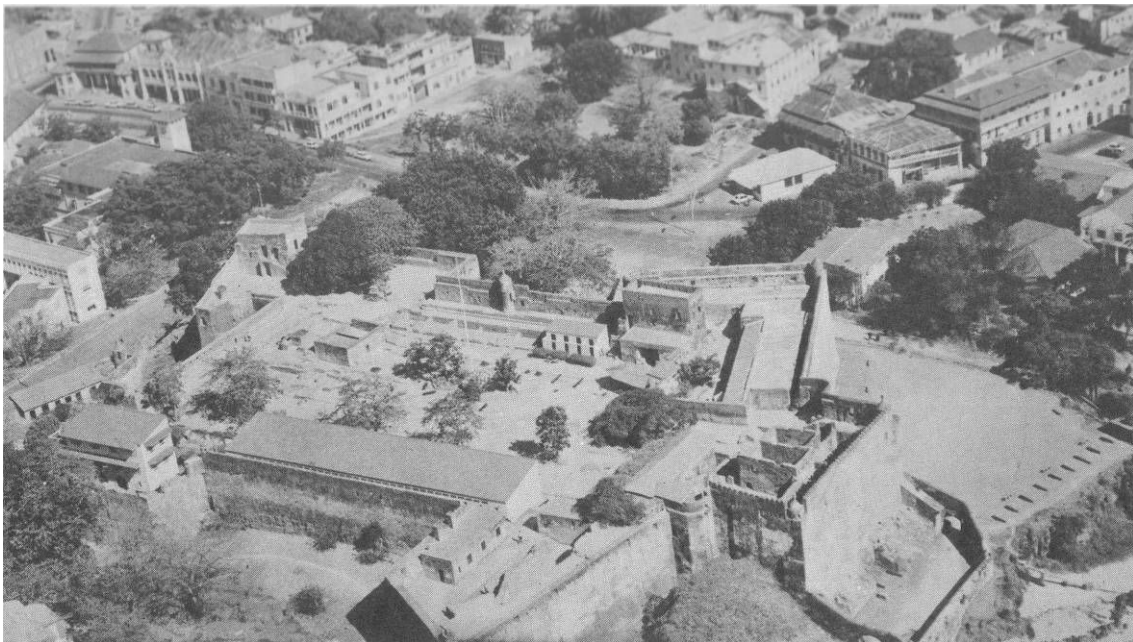

Fig. 21. Aerial view of Fort *São Jesus*. (From Kirkman 1975, 5.)



Fig. 22. Mombasa and Fort *São Jesus* by Bocarro. (From Bocarro 1992, pl. III)

The fort was located on a coral ridge at the entrance to the harbor.<sup>122</sup> The design of the fort ensured the best protection of both land and sea because of the proximity to the sea and the topography of the landscape around it.

The length of the walls between the bastions was determined according to the optimal firing range of contemporary artillery, one of the characteristics adhered to by the Italian Architectural school.<sup>123</sup> The two bastions facing the land were designed to be

---

<sup>122</sup> Kirkman 1975, 1.

<sup>123</sup> Boxer and Azevedo 1960, 96.

symmetrical, and to provide a cross-fire range over a large area. These were the bastions of *São Filipe* and *Santo Alberto*, the latter to be renamed in 1648 the *Santo António* Bastion.<sup>124</sup> The remaining two bastions were built facing the sea to control the entrance of the bay. They were designed to cover the largest area. These were called the *São Mateus* and *São Matias* bastions.

Fort *São Jesus* was planned according to the contemporary humanistic school of thought. Humanists believed that the body of man was the most perfect of God's designs and in keeping with this idea Italian military fortifications imitated the proportions of a human body. This fort is a perfect example of these ideas with its sea bastions representing the arms and head of the human model and the land bastions representing its legs, a favorite plan in Italian architecture of the sixteenth century.<sup>125</sup> To the experienced eye, this Italian school of thought is present in the main characteristics of the fort: the bastions at the edge of the beach were built to cover a wide area of the harbour. Concentrations of cross-fire were planned to deter land assault, and the gateway is well protected under the *oreillon*, the round portion at the base of arrowhead shaped bastions of *São Matias* Bastion. These features are typical sixteenth-century Italian and built with a straight cut. The only exception to the rule is the *oreillon* of *São Matias* Bastion which is rounded, but nevertheless conforms to some of the preferences of Italian military theorists.<sup>126</sup> The dry moat constructed to protect the fort from land forces is also a typical sixteenth-

---

<sup>124</sup> Pinto 2002, 24.

<sup>125</sup> Boxer and Azevedo 1960, 110.

<sup>126</sup> Boxer and Azevedo 1960, 111.

century characteristic. To this day, the plan of Fort *São Jesus* is considered, “a culminating point of Italianate military Architecture.”<sup>127</sup>

The walls were made of coral, a cheap and readily available material. The initial planned height of the walls was 13 meters. However, later restorations added three meters to this height, making for a total of 16 meters. The moat that surrounds the fort ranges from three to 12 meters in width. However, this moat was never totally finished. Access to the main gate behind the *São Matias oreillon* was almost certainly achieved by a drawbridge.

As mentioned above, this fortress kept its original plan almost without modifications.

The main changes to the original plan were the addition of two passages on the sea side of the fort and the addition of a third passage in the south-east bastion, which is also a sea bastion.<sup>128</sup> These changes are historically credited to the first Captain of Mombasa (1593 - 1596), Mateus Mendes de Vasconcelos.<sup>129</sup> Two other constructions were eventually added: the elliptical bastion and the outer gate, which was erected after the Arab revolt of 1631. These modifications did not constitute any major reconstruction of the fort walls because the fort itself was not completed until 1639.

---

<sup>127</sup> Boxer and Azevedo 1960, 117.

<sup>128</sup> Kirkman 1975, 1.

<sup>129</sup> Kirkman 1975, 3; see also Boxer and Azevedo 1960, 99.

## Fort construction

Fort Jesus was intended as base for Portuguese command of the area from *Brava* (Baraawe) to *Cape Delgado*, including the islands of Pemba, Pate, Lamu, and Zanzibar (Fig. 20).<sup>130</sup> Construction was started enthusiastically under its first captain, Mateus Mendes de Vasconcelos, but the pace of the work decreased considerably during the command of the following captains.<sup>131</sup> Before the end of 1597, Dom Francisco da Gama inspected the fort at the request of the Portuguese crown, who believed the fort to be completed. Da Gama, however, told the court that this was a false assumption and that a great amount of work was still necessary, including the raising of several outer walls. In 1605 the captain of Fort *São Jesus* received orders from the crown to finish raising the walls as quickly as possible and to build a cistern.<sup>132</sup> A second group of orders from the crown, sent to the Portuguese trading post in Diu in 1611, instructed the captain to seek additional funds and deliver the money to the captain of the fort.<sup>133</sup> Nevertheless the construction of the fort progressed slowly. By 1614 the crown again urged its officials to complete the fortress's outer walls after receiving complaints from the Mombassa merchants. However, in spite of specific instructions from the viceroy in the same year, the task proved difficult and expensive, and although two conscientious captains, Francisco de Sousa Pereira and João Pereira Semedo, did what they could to continue to expedite the construction of the fort, it was still not completed by August 1631 when the

---

<sup>130</sup> Pinto 2002, 25.

<sup>131</sup> Boxer and Azevedo 1960, 88.

<sup>132</sup> Boxer and Azevedo 1960, 98.

<sup>133</sup> Axelson 1960, 79.



local population again revolted against the Portuguese. This revolt resulted in the massacre of both the garrison and the Portuguese merchants and families living in Mombassa. After successful punitive expeditions that succeeded in retaking the area, the new Portuguese captain was again charged with the completion of the fortress. Captain Francisco de Seixas Cabreira managed to finish the work between the reoccupation of the fort in 1633 and the end of his career in Mombassa in 1639.<sup>134</sup> The fort was finished as it stands today.

During its history under Portuguese rule, Fort *São Jesus* was never heavily garrisoned and generally had between 200 to 400 Portuguese soldiers, some merchants, and the merchants' and soldiers' families. A plan from 1610 shows the accommodations available in the fort (Fig. 23).

#### Organization of the fort

The fort garrison was organized and manned under the direction of a captain who was appointed for a period of three years.

---

<sup>134</sup> Boxer and Azevedo 1960, 99.

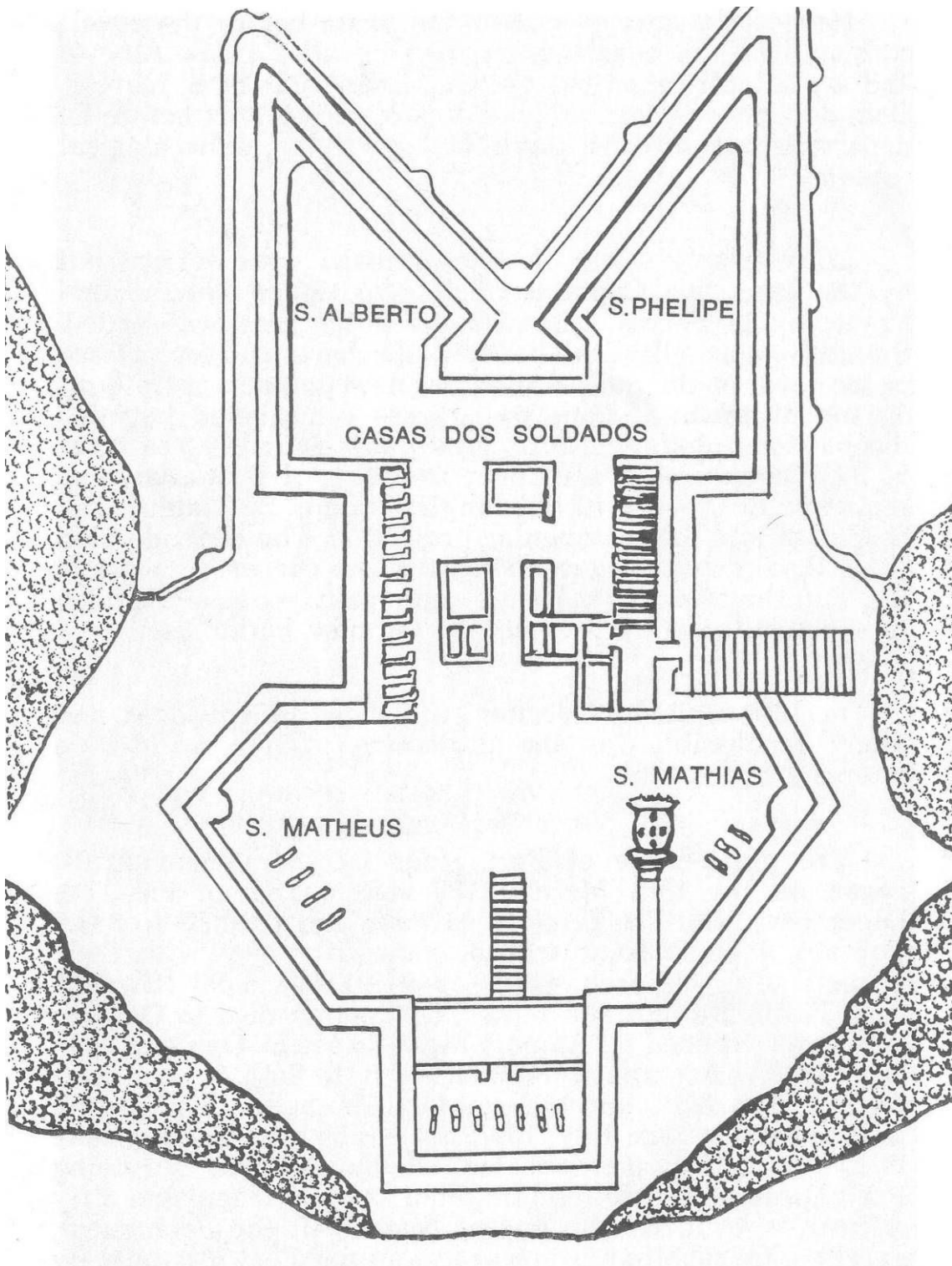

Fig. 23. Plan of 1610 by Manuel Godinho de Herédia. (From Kirkman 1975, 3.)

The captain's powers were extensive, although they were kept in check by the crown's appointed local judge. The captain was charged with the protection of the crown's judge, the clerk of the trade post, and the factor, who also served as the military governor.<sup>135</sup> Although these three officers were not under the captain's direct command the truth is that they seldom questioned or hindered the captain's orders, especially in cases when they stood to benefit from advantageous decisions.

Under the captain's direct command there were generally 94 soldiers, one gatekeeper, one inspector of the watch, two barrack captains, and two sea captains with 80 sailors. He also had one master-gunner and four gunners. For the maintenance of the fort the captain had four masons, two carpenters and one blacksmith. In all, the captain oversaw a total of 192 men. He was also responsible for the safety of the non-military personal, including the wives and children of the soldiers, the merchants, and the local clergymen. The latter was comprised of friars from the convent of Saint Augustine, the Father-Vicar of the Mother Church (main church), and two local vicars.<sup>136</sup>

## History

The fort was originally intended by the crown to stay under the rule and good graces of the Sultan of Malindi. This fact is mentioned in numerous letters from the crown to the fort's captains.<sup>137</sup> Furthermore, the prevalence of the Malindi faction within the Swahili

---

<sup>135</sup> Bocarro 1992, 36-7.

<sup>136</sup> Bocarro 1992, 36-7.

<sup>137</sup> Berg 1968, 45.

culture created a better and more amicable relationship with the Portuguese; it was in the best interest of the Iberian crown that the Sultan of Malindi's power over his subjects be beyond question. The defense of Mombasa depended on amicable relations with the sultan.<sup>138</sup>

Fort *São Jesus* therefore played an important role in the relations between the Swahili and the Portuguese. It was a vital bridge between the Portuguese and the local tribes, whom the Portuguese called *Muzungulos*, and who called themselves Nyika. Most of the relations between the local Nyika and the Portuguese were carried out through Swahili intermediaries, but the Nyika played an important role in the Fort's history.<sup>139</sup>

For a number of reasons, the captains of the fort repeatedly mishandled relations with the sultan. Sometimes taxes due to the sultan were not delivered and in several occasions his overlordship of Pemba was questioned, his trade privileges were sabotaged, and his fiscal and administrative privileges were ignored.<sup>140</sup> The strained relations with local Swahili reached their climax when the sultan was assassinated by the Nyika at the instigation of Simão Pereira de Melo, captain of the fort in 1614.<sup>141</sup> He was succeeded by the sultan's son, Dom Jerónimo, generally known by his Muslim name Yusuf-bin-Hasan. Sultan Dom Jerónimo had a difficult task as the new ruler of the Swahili. He was a converted Christian, something that did not go well with his Muslim subjects,

---

<sup>138</sup> Axelson 1960, 79.

<sup>139</sup> Boxer and Azevedo 1960, 24.

<sup>140</sup> Boxer and Azevedo 1960, 34.

<sup>141</sup> Kirkman 1983, 75.

especially among the remaining noblemen. These Sherik noblemen were a subjugated oligarchy whose ancestors had reigned before the arrival of the Portuguese and who aligned continually with Muslim neighbors in the hope of returning to power. The sultan's only Christian allies, the Portuguese, were responsible for the death of his father. Even worse, the Portuguese captain doubted that Dom Jerónimo had ever fully converted to Christianity and continued to ignore and undermine the sultan's authority.

The crown investigated the matter of the murder of the sultan, father of Dom Jerónimo, but the results of the investigation seem to have disappeared on arrival at Goa and never reached Spain. It is currently believed that the results would have indicted Captain Pereira de Melo. Be that it as it may, the captain had powerful friends in Goa and no news ever reached the crown officers in Lisbon, let alone Madrid.<sup>142</sup>

In August 1631 the Portuguese captain was about to indict the new sultan on charges of heresy, but Dom Jerónimo was forewarned. On August 15, the day of Our Lady of Assumption, Dom Jerónimo went to visit the Portuguese with his escort. Once inside the fort he gave orders to his escort to kill the garrison. While Dom Jerónimo secured the fort the local population massacred the Portuguese residents in Mombasa in a coordinated attack. The sultan assumed his Muslim name Yusuf-bin-Hasan and tried to raise the whole Swahili coast against the Portuguese. However, he was unable to do so. The continuing loyalty of the other cities was due to Alvares Pereira, a crown judge who

---

<sup>142</sup> Axelson 1960, 83.

appealed the local rulers by administering justice against abusive Portuguese.<sup>143</sup> A punitive expedition of 100 men was sent to retake the fort but the overconfidence of the Portuguese and the excellent design of the fort brought victory to Sultan Yusuf.<sup>144</sup> Credit must also be given to the Nyika, whose poisoned arrows severely damaged the Portuguese forces.<sup>145</sup>

The rule of Yusuf-bin-Hasan did not last long. Later events led the Sultan to evacuate the area and flee to the city of Pate, which agreed to harbor him and turn against the Portuguese. In Mombasa, the fort was reoccupied by Portuguese troops in August 1632 thanks to the insight of a veteran captain named Pedro Rodrigues Coelho in command of a force of 75 men.

The pacification of the area took another five years due to revolts in several of the neighboring Muslim cities which, following the example of Mombasa, occasionally revolted against the Portuguese rule. Only in 1637 was Francisco de Seixas, the new captain of the fort, able to force the cities of Siu and Manda in Manda Island, Lamu, and Pate into submission. (Fig. 24).

---

<sup>143</sup> Axelson 1960, 85-6.

<sup>144</sup> Boxer and Azevedo 1960, 37.

<sup>145</sup> Kirkman 1983, 75.

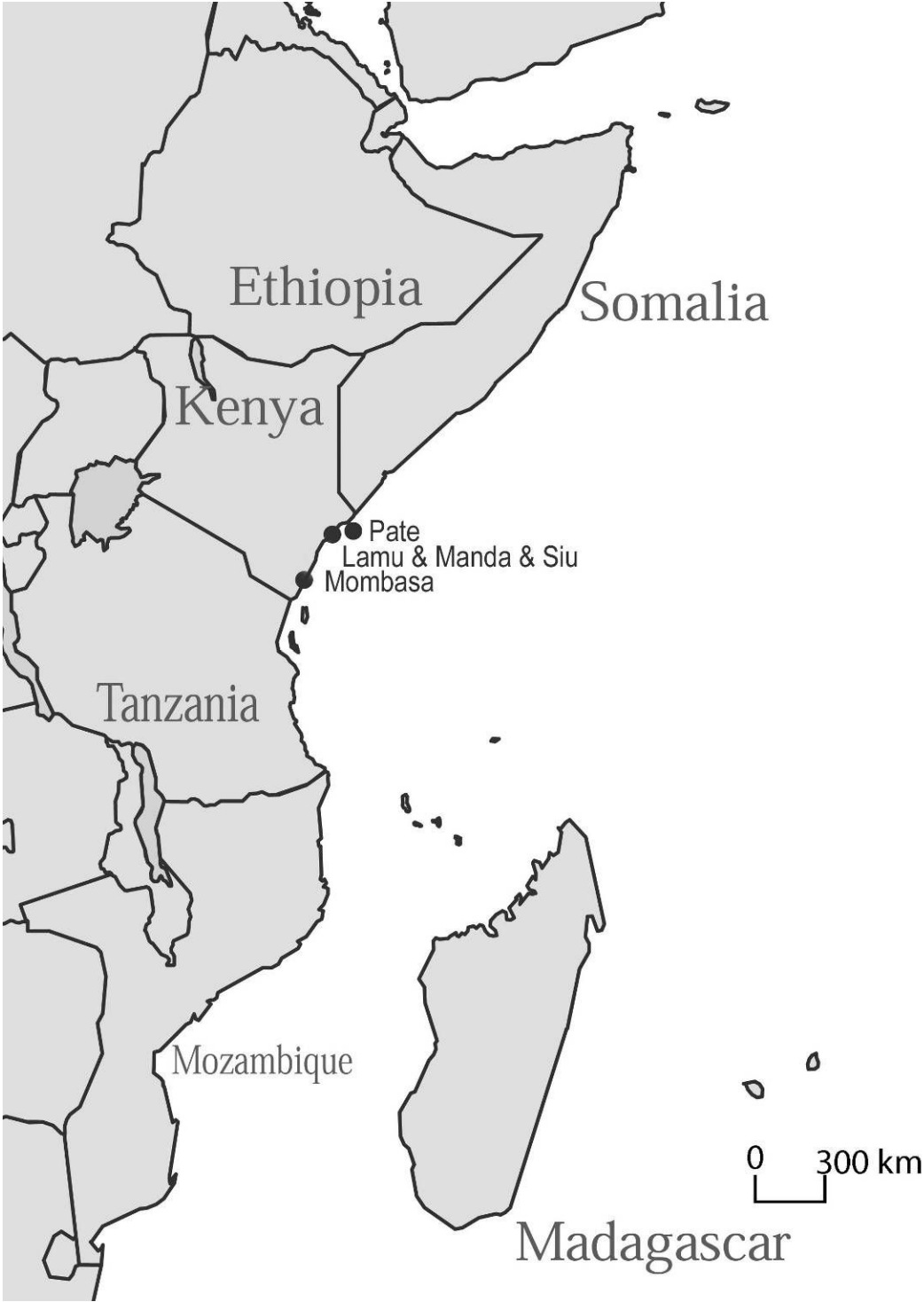

Fig. 24. The location of the revolting cities.

Relations between the vanquished cities and the fort did not improve, and in 1644 the Portuguese destroyed the customs house of Pate (the source of income for the local sultan) and forced all shipping to go through Mombasa and to pay lading charges there. Rulers on the entire Swahili coast complained to the Portuguese crown, recently independent from Spain, about the harsh treatment imposed on them by Portuguese captains. Investigations found the fort captains and officers guilty and subsequent letters from Lisbon ordering the disciplining of those officials and the establishment of good relations with the local rulers seems to have been largely ignored. This was the prelude for yet another open revolt on the Swahili coast.<sup>146</sup>

This time the Swahili had a powerful new ally in the ascendant Omani Arabs. In 1650 the Swahili coast was crowded with Omani pirate vessels and the Portuguese found themselves slowly losing control of the water. Francisco de Seixas was again sent to restore peace to the area and succeeded in his endeavor. Unfortunately, the Portuguese forces were at this time under siege by several new competitors from Europe. Supported by the English crown, the Omani forces were becoming increasingly dangerous, a situation worsened by a new growing conflict with the Dutch merchants in the Portuguese Indies. This state of affairs brought major new troubles to the Portuguese in the following years. Several strongholds were lost to the Dutch V.O.C. forces on Ceylon and the Omani sacked Mombassa in 1660 and 1661. Fort *São Jesus* was powerless to prevent these events. Bombay, Diu, and the Bassein territories on the Indian

---

<sup>146</sup> Boxer and Azevedo 1960, 45.



subcontinent were also sacked by the Omani. Only when peace with the Dutch was restored in 1663 did the Portuguese find the resources to confront the Omani threat. Even after the Portuguese deployed naval fleets to curb their Arab foes the situation remained difficult in the Persian Gulf and it was not until 1678 that the Portuguese regained partial control of the area. On December 16, 1678, a Portuguese expedition once again conquered the city of Pate, the main nest of Portuguese enemies on the East African Coast and the main base of the Omani pirates. Only after the prompt execution of the sultan of Pate (as well as those of Lamu, Siu, and Manda, and some of their nobles) was the city of Pate pacified. However, a few days after the executions an Omani relief force sent to help the city forced the Portuguese army to retreat to Mozambique.<sup>147</sup>

In 1687 the Portuguese again re-conquered Pate and the defeated Sultan of Pate was sent to Goa as a hostage together with some of his closest advisors. The release of the Sultan of Pate depended on his signing a treaty that made him a vassal of the Portuguese crown. Later events determined that the city was given to the Sultan of Faze, a trusted ally of the Portuguese, as the Sultan of Pate was deemed untrustworthy. This issue was resolved even before instructions from the crown reached Goa. On Christmas Day 1688 the hostages were killed in Goa during a failed escape attempt.

The area finally seemed pacified and a civil war in the Omani empire seemed to preclude any further Omani help to the local Swahili resistance. Peace lasted until 1694, when the

---

<sup>147</sup> Boxer and Azevedo 1960, 48-9.

Omani civil war came to an end and Pemba, the main supply city of Mombasa, revolted against the Portuguese rule. Pate and Muscat eventually followed the uprising and Omani aid was again requested. Once again a punitive expedition led by the Portuguese regained the city of Pemba at the end of the same year. The governor of Mombassa requested the viceroyalty to send reinforcements against an expected Omani invasion but the threat did not seem pressing and no additional reinforcements were sent to Fort *São Jesus*.<sup>148</sup>

On 13 March 1696 an army of 3,000 Omani troops under the command of the Prince of Lamu arrived and besieged the fort. This siege lasted until 13 December 1698 -- two years and nine months --, and ended with the capitulation of the Portuguese. The history of the siege exposes the difficulty of either side securing a decisive and lasting victory.<sup>149</sup> The main causes of the loss of the fortress were the lack of reinforcements for the soldiers inside the fort, the lack of provisions (in spite of a continuous although insufficient supply by the Nyika), and finally an outbreak of plague.<sup>150</sup>

The loss of Fort *São Jesus* was decisively delayed by the actions of Captain Joseph Pereira de Brito, stranded inside the besieged fort with the newly-appointed Governor of Mozambique, Melo de Sampaio, after the loss of the relief frigate *Santo Antonio de Tanná*, on 20 October 1697. During the siege Captain de Brito rallied the local garrison

---

<sup>148</sup> Boxer and Azevedo 1960, 58.

<sup>149</sup> Boxer and Azevedo 1960, 61.

<sup>150</sup> Kirkman 1983, 77-8.

and all the Portuguese personnel available, and carried out successful raids against the enemy, destroying almost all of their batteries.

A third relief force was eventually sent from Goa in 1698, arriving at Mombasa in December, under the command of Francisco Pereira da Silva, who refused, as Sampaio had not, to do anything that would endanger his ships and looked upon his role as a supply operation. Some claim that with his three frigates he would probably have managed to drive the Omani forces away. Had he entered the bay and bombarded their positions they probably would have abandoned their positions as it seems they had been ordered to. For how long is the pertinent question. Captain Pereira de Brito, his soldiers, and several of the locals embarked on the ships from the third relief force and left the fort with the disheartened garrison forces under the command of Leandro Barbosa Soutomaior, from whom it was said that his only known achievement was to alienate the local Swahili troops to the point that they all left the fort.

Even if the history of the Portuguese presence in Mombasa could have been changed, the saving of the fort would perhaps only have, in the views of historian Eric Axelson, “prolonged the agony of Fort Jesus and completed the exhaustion of Portuguese India.”<sup>151</sup> The differences between the local population and the Portuguese, combined with the ascent of the Omani Arab influence in the region, and the rise of English power

---

<sup>151</sup> Axelson 1960, 175.

in the East would predictably have given the Swahili other opportunities to revolt and to replace one protection by another.<sup>152</sup>

The Swahili coast remained under Omani protection, but the Arabs alienated the Swahili as much as the Portuguese rulers had and by 1727 the cities of Pate and Mombasa rebelled against the Omani and requested the protection of the Portuguese. A Portuguese force, under the joint command of prince Dau of Faza and Luis de Mello de Sampaio (a captain with the same name as the governor of Mozambique) arrived in January of that year and helped to beat an Arab punitive expedition and retook the fort. The Portuguese were surprised by the fact that instead of an Arab garrison, the fort was manned by rebellious African slaves. After negotiations this garrison was permitted to leave unarmed.<sup>153</sup>

The new Portuguese ruler was given authority over the entire Swahili coast but the ivory trade was to be carried out under the shared control of both the Portuguese and the local rulers, the exception being the trade in the ports of Mombasa, Kilwa, Mafia, and Kwale, which were controlled solely by the Portuguese crown. Again, local politics made it impossible to maintain peace. Eventually the Portuguese governor of Mombassa, Alvaro Caetano de Mello e Castro, found himself at odds with the Sultan of Mombassa, the prince of Dau, the Muslim leader Manni Hanid, and even with the local Nyika tribes, upon whom the supplies of the fort depended.

---

<sup>152</sup> Axelson 1960, 175.

<sup>153</sup> Boxer and Azevedo 1960, 77.

In April 1729 a joint revolt of Manni Hanid and the Nyika people found support among the Pemba, Mafia, and Zanzibar populations, and Fort *São Jesus* was besieged once again. The fortress capitulated to the Arab forces in October and Mello e Castro left for Mozambique on 26 November 1729. An expedition was sent to retake the fort in 1730, but to no avail. Luis de Melo de Sampaio met with Mello e Castro in Mozambique and decided to sail to Goa and prepare another attempt to reconquer the fort. However, the fleet sailing to Goa was caught by a hurricane and the flagship sank with Melo de Sampaio on board.<sup>154</sup> This was the end of the Portuguese occupation of Fort *São Jesus* in Mombasa.

The fort fell under Omani rule until 1741, when the local sultan declared independence, but independence did not last long. The Mombasa Sultanate was forced to become an English protectorate to avoid being conquered by the Omani again in 1824. Nevertheless, four years later the fort was once more taken by Omani forces and only returned to the local rulers in 1837, where it became under the sovereignty of the Sultan of Zanzibar. In 1895 Mombasa was formally declared part of Britain's Kenya protectorate, (the sultan formally presented Mombasa to the British in 1898) and the fort was converted into a prison, until 1958 when it was transformed into a monument, restored by the Portuguese Calouste Gulbenkian Foundation, under the direction of James Kirkman (whom excavated the fort from 1958 to 1971), and became a possession of the Kenya National Parks Service. In 1963, Mombasa town was officially ceded by the state of Zanzibar to

---

<sup>154</sup> Boxer and Azevedo 1960, 82.

the newly independent republic of Kenya. In 1969, it was transformed into the Fort Jesus Museum (under the care of the Museum Trustee of Kenya) and today it houses an exhibition of *Santo Antonio de Tanná* artifacts, recovered by the Institute of Nautical Archaeology between 1977 and 1980 (Fig. 25).<sup>155</sup>

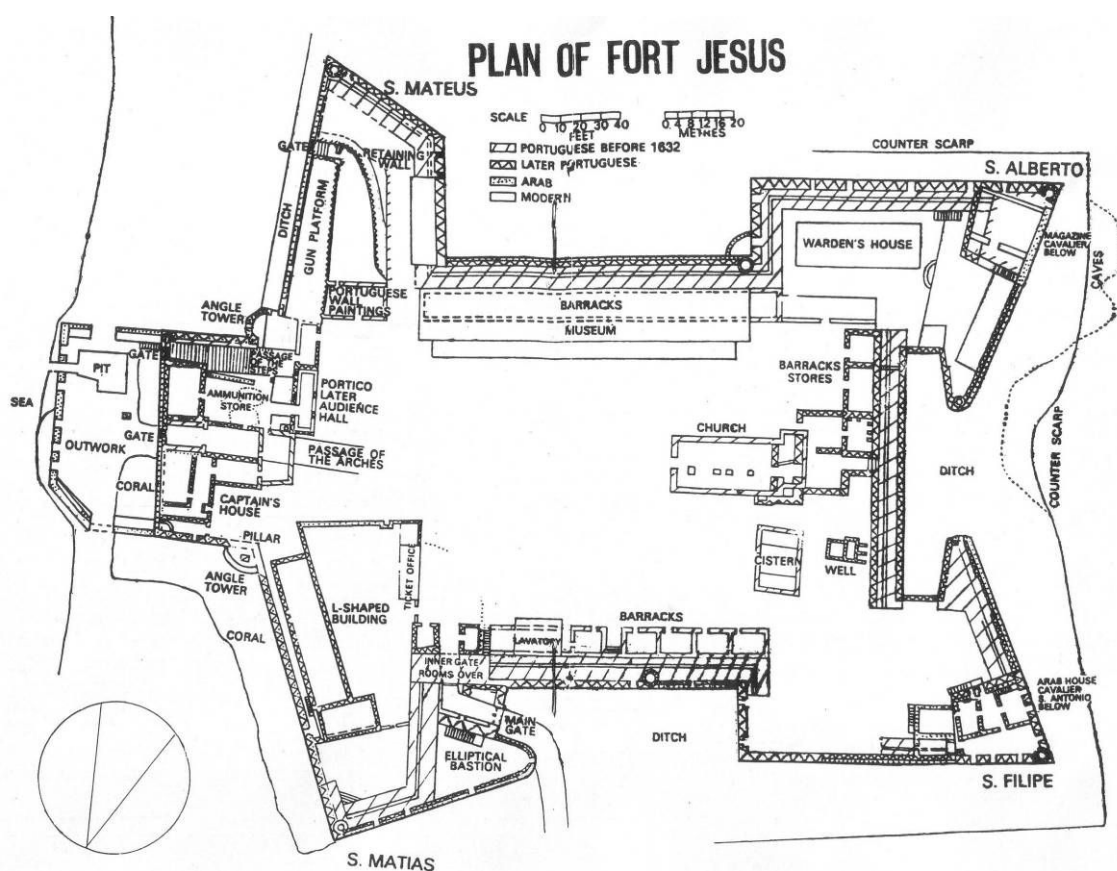

Fig. 25. Plan of Fort *São Jesus* as it stands today. (From Kirkman 1975, 14-5)

<sup>155</sup> Kirkman 1975, 10.

This chapter concludes the historical part of this thesis. The next chapters present the steps taken to reconstruct *Santo Antonio de Tanná*'s hull, starting with the available written sources for the reconstruction study.

## CHAPTER VI

### WRITTEN SOURCES FOR RECONSTRUCTION

The reconstruction of *Santo Antonio de Tanná* presented in this thesis depended largely on available historical and iconographical information to fill the gaps in the archaeological record. Thus, a thorough study of written sources and iconography was a vital first step in creating a plausible reconstruction of a late seventeenth century Portuguese frigate. Shipbuilding treatises, from the generic accounts of building to works that specifically address frigate construction, proved the best way to fill those gaps.

The most important sources that originate from the seventeenth century were consulted and included in this study. The rapid development of the frigate type during that century was taken into account in the analysis of these sources and their applicability to the study was considered to decrease with every decade before and after the 1680s (the construction date of *Santo Antonio de Tanná*). Treatises from the first half of the seventeenth century were studied, but due to the rapidity of the changes in ship design, none yielded a significant contribution to the *Santo Antonio de Tanná* reconstruction. Written sources from European countries that developed frigates for use in the Indian Ocean were specifically considered. The research was restricted to countries from which the Portuguese were likely to have shared, or benefited from, shipbuilding traditions. This excluded countries with excellent shipbuilding traditions, such as Italy or the



Netherlands, but which differed substantially in shipbuilding techniques from what were likely to be the standard Portuguese practices.

Aside from Portugal, this study focused on three countries: Spain for its close cultural and technological ties with Portugal, England for being an important naval power and a close ally of Portugal, and France, the country with naval shipbuilding techniques that were unsurpassed in the seventeenth century by any other European naval power.

## Portugal

Several documents pertaining to the building of frigates in Portugal and dating to the seventeenth century were located and studied. These included three treatises, a group of instructions, or *regimentos*, to build frigates, and an anonymous scantlings list. The treatises were:

*Tratado do que deue saber hũ bom Soldado p.<sup>a</sup> Ser bom Capitan de Mar e gerra*, signed by Caetano de Almeida Ramos and written sometime during the middle seventeenth century;<sup>156</sup> *Livro Primeiro de Arquitectura Naval*, by João Baptista Lavanha's, penned sometime around 1610;<sup>157</sup> and *Livro de Traças de Carpintaria*, by Manuel Fernandez's, dated to 1616;<sup>158</sup>

---

<sup>156</sup> Madahil 1934.

<sup>157</sup> Lavanha 1996.

<sup>158</sup> Fernandez 1989.

The *regimentos* were lists of general dimensions for the construction of a number of frigates which were sent from Portugal to the crown shipyards in India in 1692. These *Regimentos* detailed the general dimensions of five frigates and the overall dimensions of the frigate *São Boaventura* and the frigates *Madre de Deus*, *São Xavier*, and *Santo António*.<sup>159</sup>

The scantling list was contained in a letter from the archives of the Portuguese Maritime Library titled *Relação Dos Nomes das peças da Construção Dos Navios e das madeiras do Brasil próprias para elas* and dated at the end of the seventeenth century.<sup>160</sup>

The *Tratado do que deue saber hũ bom Soldado p.<sup>a</sup> Ser bom Capitan de Mar e Gerra* was composed of three parts. The first part informed the reader of the qualities one must possess to be a good sea captain. The second part covered the dimensions for the construction of galleons; this included the principal dimensions of a ship, its castles and beak-head, and its masts and yards. The final part was a small but useful dictionary of key components on a ship.

In his *Livro Primeiro de Architectura Naval*, João Baptista Lavanha dealt exclusively with the design of a Portuguese Indiaman from the beginning of the seventeenth century. This Indiaman was substantially different from a frigate such as *Santo Antonio de Tanná* and has already been studied in a dissertation from Texas A&M Nautical Archaeology

---

<sup>159</sup> Jordan 2001, 313.

<sup>160</sup> This manuscript was referred to me by Dr. Lui Filipe Vieira de Castro who found it in the Biblioteca Central de Marinha in Lisbon.

Program.<sup>161</sup> In spite of being almost one century too early – and a century that saw dramatic changes in the design of warships – it was an important tool because of its exceptionally well-documented construction details and explanations of ship design processes.

Fernandez's *Traças de Carpintaria* was a compilation of measures for ten types of ships, describing 30 ships in total. The original manuscript was possibly intended to be a gift to the new Habsburg king Filipe II of Portugal (Philip III of Spain).<sup>162</sup> It was dated to 1616, early for the study considered here, and it included several Tagus frigates (*fragatas*) the boat tenders referred to in Chapter III; these *fragatas*, as we have seen, were substantially different from the frigates at the end of that century. However, Fernandez mentioned three war vessels named *patachos*, of which one is titled *Patacho Holandez*, translated in the English version as a Dutch brigantine. It is possible that this ship was related to some type of Flemish Dunkirker. If this was true, the drawings could provide insight to the evolution of the frigate and may be of interest as a stage in the development of the late seventeenth century frigate (as mentioned in Chapter III).<sup>163</sup> Beautifully illustrated with colored scale drawings of all the ships described, Fernandez' book was an important source for the reconstruction of the frigate *Santo Antonio de Tanná* presented here. In spite of its early date, it showed construction details that were likely repeated throughout the century by Portuguese shipwrights.

---

<sup>161</sup> Castro 2001.

<sup>162</sup> Rahn-Phillips 2000.

<sup>163</sup> Fernandez 1995, 144.

The frigate *Regimentos*, mentioned above, were published in an extensive collection of documents pertaining to the Portuguese navy after 1640 titled *Três Séculos do Mar*.<sup>164</sup> As mentioned above, these documents are believed to have been sent from Portugal to Goa on the western coast of India in 1692. An introductory letter from the king is attached to these *Regimentos* and instructs the viceroy of India to follow them closely.<sup>165</sup> The *Regimentos* themselves were signed by Manuel Jacome. In these documents, the general dimensions for frigates from 11 *rumos* (16.96 m) to 21 *rumos* (32.34 m) in length were enumerated.<sup>166</sup> This document additionally provided a list of instructions with proportions for the construction of four specific frigates with two different sizes. These were the frigate *São Boaventura*, with 17.5 *rumos* (26.95 m) of keel length, and *Madre de Deurs, São Xavier e Santo António*, all frigates with 21.5 *rumos* (33.11 m) of keel length.<sup>167</sup> Investigators Jean-Yves Blot and Maria Luisa Blot stated that there was an intention to construct the *São Boaventura* according to the dimensions of *Santo Antonio de Tanná*.<sup>168</sup> Although there was no certainty that their intention was carried out, these dimensions have been the basis of the reconstruction work.

Finally, the *Relação Dos Nomes das peças da Construção Dos Navios* consisted of a list of 75 components of a ship and the wood types to be used in their manufacture. This document was leather bound together with several other documents under the heading

---

<sup>164</sup> Esparteiro 1987, 52-4.

<sup>165</sup> Pona 1890, 218-9.

<sup>166</sup> One *rumo* is equivalent to 154 centimeters (Castro 2001, 287-9).

<sup>167</sup> Esparteiro 1987, 256-7.

<sup>168</sup> Blot and Blot 1984, 39.

Manuscript 52 in the Portuguese Naval Library. The document was unsigned and undated, but its watermark and the associated documents suggest a tentative date of 1691.<sup>169</sup>

Of all these texts, the two crucial documents that aided the most in the reconstruction work were the *regimentos* sent to Goa and the *Relação Dos Nomes das peças da Construção Dos Navios*. The *Regimento* post dates the building of *Santo Antonio de Tanná* by 11 years. As mentioned before, although the frigate design had a rapid evolution during the seventeenth century, this document was the best source available for the understanding of this ship type in Portugal in the last decades of that century. It is safe to assume that the dimensions and rules presented there were representative of frigates -- such as *Santo Antonio de Tanná* -- built a decade earlier. On the other hand, the *Relação* only post dates the construction of the frigate by ten years. And although it is intended for the building of ships with Brazilian timbers (the India-built *Santo Antonio de Tanná* was apparently made entirely of teak) it stands as a reliable source list of hull components.

## Spain

Four treatises and three establishments survived from seventeenth century Spain: The *Arte para fabricar, aparejar naos de guerra y merchante*, written by Tomé Cano in

---

<sup>169</sup> Filipe Castro, personal communication June 2005.

1611;<sup>170</sup> the *Diálogos entre un viscaíno y un montañés*, possibly composed by Pedro Lopes de Soto around 1631 or 1632;<sup>171</sup> the *Arte de fabricar reales*, penned by D. José Antonio de Gazstañeta Yturribalzaga in 1688;<sup>172</sup> the *Norte de La Contratación de las Indias Occidentales* by José de Veitia Linage, also dated to 1688 and The Habsburg *Ordenanzas* of 1607, 1613, and 1618.

Tomé Cano's *Arte para fabricar, aparejar naos de guerra y merchante* of 1611 was a treatise on general ship design, presented in the form of a discussion between three friends.<sup>173</sup> It began by explaining the problems with the West Indiamen built in Spain and ended with the dimensions of a ship of 278 tons burden. As was the case with the Indiamen in the Portuguese treatises, this one also dated to the beginning of the seventeenth century and was substantially different from *Santo Antonio de Tanná*.

The author of *Diálogos entre un viscaíno y un Montañés* of circa 1631 or 1632, presumed to be Pedro Lopes de Soto, wrote this treatise in the form of a conversation about shipbuilding between two Basque citizens.<sup>174</sup> The treatise followed the structure of other contemporaneous treatises. Starting with a section on the origins of ships, it continued with dimensions, scantlings and the rigging required for galleons and smaller ships named *patachos*, and ended with a summation of the ordnance and number of men required for those ships.

---

<sup>170</sup> Duro 1996.

<sup>171</sup> Vicente Maroto 1998, 21 -26.

<sup>172</sup> Gonzáles et al 1992.

<sup>173</sup> Duro 1996.

<sup>174</sup> Vicente Maroto 1998, 14.

D. José Antonio de Gazstañeta Yturribalzaga's *Arte de fabricar reales* of 1688 was a treatise on the construction of the ship *Nuestra Señora de la Concepción y Las Animas*.<sup>175</sup> This was one of the most complete treatises on shipbuilding of its time. In its 177 chapters every phase of the construction of the *Nuestra Señora de la Concepción y Las Animas* was recorded and explained. As was the custom in Medieval and Early-Modern age treatises, interspersed among the pages of the main subject there were pages with information about other ships, defining the best time to cut timbers, explaining how to make ink and, more to the subject of this thesis, pages with the basic measurements of two *fragatas*.<sup>176</sup>

José de Veitia Linage, *Norte de La Cantratación de las Indias Occidentales* of 1688, was a two volume book that covers almost every naval matter pertaining to the Spanish West Indies.<sup>177</sup> The first volume dealt with the administrative organization and proceedings of the institutions relating to the Spanish West Indies. Also included in the first volume were dimensions for the construction of two galleons of 500 and 700 tons respectively. The second volume dealt with ship classifications and the hierarchy of ship captains and officers.

The Habsburg *Ordenanzas* were Spanish laws commissioned by King Philip III (Philip II of Portugal) pertaining to naval matters. The first, published in 1607, was a collection of measures for ships and galleons up to 1184 tons and payment instructions for

---

<sup>175</sup> Gonzáles et al 1992, 1:7.

<sup>176</sup> Gonzáles et al 1992, 1:79-80.

<sup>177</sup> Linage 1688.

shipbuilders and seamen. The edition of 1613 had revised payment instructions and measures. However, in contrast to preceding law which classified ships by tonnage, the 1613 *Ordenanza* classified ships by keel length. Another difference was the inclusion of the measures for three *patachos*. The third *Ordenanzas*, published in 1618, were a compilation of general measurements for ships according to keel length.

There were other *Ordenanzas* issued during the seventeenth century which set the basic dimensions and proportions of Spain's ships of war. The study of early seventeenth century Spanish treatises provided a glimpse into the proto-frigates of that era. However, in spite of the gradual merger of Portuguese and Spanish shipbuilding which occurred during the period of Hapsburg domination (1580-1640), Portugal's independence, regained in 1640, separated the two crowns. After 1640 Spain underwent a period of decadence that makes the study of its legislation largely irrelevant for the reconstruction of *Santo Antonio de Tanná*; mostly in light of the works of Veitia Linage and Gazstañeta Yturribalzaga, both more informative than Spain's legislation.<sup>178</sup>

In truth, Gazstañeta Yturribalzaga's work is the only one that gave some clues about how a late seventeenth-century Spanish frigate would be built, thanks to its inclusion of two contemporary *fragatas*.

---

<sup>178</sup> Serrano Mangas 1992, 1985.



## England

At least five treatises from the seventeenth century concern the construction of ships in England. These included *Newton's Manuscript* written by Isaac Newton in 1600;<sup>179</sup> The anonymous *Scott Manuscript* from 1600-20;<sup>180</sup> *A Treatise on Shipbuilding c.1620*, sometimes attributed to John Wells;<sup>181</sup> Edmund Bushnell's *The complete Shipwright*, composed in 1664,<sup>182</sup> and Anthony Deane's *Doctrine of Naval Architecture of 1670*.

Both the *Newton's* and *Scott* manuscripts seemed to be either copies of previous treatises or inspired by one another. *Newton's Manuscript* was a collection of miscellaneous material, which included a shipbuilding document copied by Newton from earlier unknown documents.<sup>183</sup> Dated to around 1600, this document addressed the dimensions of ships and was divided into three sections. The first section gave the proportions of the ship and how those proportions related to one another, the second section dealt with the instructions for the practical application of the first, and the last section referred to the ship's masts and yards. The section on masts and yards was very similar to the one in the *Scott Manuscript*, which was unpublished and belongs to the Royal Institution of Naval Architects.<sup>184</sup>

---

<sup>179</sup> Barker 1994, 16-29.

<sup>180</sup> Castro 2002, 29 October.

<sup>181</sup> Salisbury and Anderson 1958.

<sup>182</sup> Bushnell 1669.

<sup>183</sup> Barker 1994, 16.

<sup>184</sup> Barker 1994, 16; see also Castro 2004, 29 October.

*A Treatise on Shipbuilding* (1620) was found in a volume containing several documents on naval matters ranging from 1565 to 1695. This treatise addressed the building of ships, but frigates were not mentioned. The treatise itself was composed of two parts. The first part described the scantlings of a vessel in detail. The second part explained the manner in which an “optical projection of the body in 3 several planes,” can be drawn upon paper.<sup>185</sup>

Bushnell’s *The Complete Shipwright* of 1664 was an instructional treatise that taught how to draw a ship correctly on paper. It was an exercise in theory for a geometric model of a ship and how to use it to attest the legitimacy of shipbuilders’ lines. The last chapters described the proportions of masts and a method for rowing a vessel in calm weather.

*Anthony Deane’s Doctrine of Naval Architecture and Tables of Dimensions, Materials, Furniture and Equipment appertaining thereto. Writen in the Yeare 1670 at the Instance of Samuel Pepys, Esq* was a treatise on all six rates of war vessels.<sup>186</sup> As was the case with Bushnell and the *Treatise on Shipbuilding*, it began by demonstrating how to project a ship upon paper. After explaining this process, Deane continued by presenting his geometric model for attesting to the correct proportions of the ship. From that point on he differed from Bushnell and the *Treatise* of 1620 by including lists of scantlings, but contrary to Bushnell and the *Treatise* he also included proportional tables for vessels

---

<sup>185</sup> Salisbury and Anderson 1958, 14.

<sup>186</sup> Abell 1981, 53.

of war from the first rate to the sixth rate.<sup>187</sup> Deane's last section gave the mast, spar and rigging proportions for those vessels and information on how to man the English rates.

Of this collection of English treatises, only Anthony Deane could be used for the study of frigates. Historically, Dean was known to have been a firm supporter of the frigate type, and to have built several (Fig. 26).<sup>188</sup> The ships portrayed in his treatise were probably built according to the frigate characteristics that he considered ideal for a vessel of war.

## France

During the period under analysis, the French produced several treatises and a collection of laws on ship design. These included the *Album de Colbert*, drafted in 1670;<sup>189</sup> Jean Jouve's *Deux albums des batiments de l'Atlantique et de la Mediterranée* completed in 1679;<sup>190</sup> The anonymous *Un manuel de construction de galères*, written in 1691;<sup>191</sup> Dassié's *l'Archictecture navale* of 1695;<sup>192</sup> Francois Lafon's 1695 republication of the anonymous *Construction de Vaisseaux du Roi*, adapted from an early 1691 document printed by Jaques Hubault, merchant librarian;<sup>193</sup> and the French government's regulations issued in 1670,1671,1673 and again in 1683, all of which pertained to shipbuilding.

---

<sup>187</sup> Lavery 1981, 74-80.

<sup>188</sup> Abell 1981, 55.

<sup>189</sup> Anonymous 1988.

<sup>190</sup> Jouve 1971.

<sup>191</sup> Castro 2002, 29 October.

<sup>192</sup> Dassié 1994.

<sup>193</sup> Lafon 1695.



Fig. 26. *Resolution*, a ship built by Deane painted by Willem Van der Velde the younger. (After Woodman 1997, 78.)

Although the *Album de Colbert* was an anonymous document, it has been attributed to Jean Jouve, and consisted of an atlas containing 50 plates depicting all the construction stages of a first rate French ship of the line. It was ordered by French Prime Minister Jean-Baptiste Colbert (1619-1683) during his years as a minister for Louis XIV. It is believed that this album is one of three that Colbert commissioned. The first, *Album de Colbert*, dated to or before 1677. A second work, dated to 1679 and similar in binding and style, shows Mediterranean ships. Its drawings have also been attributed to Jean Jouve of Marseille. A third album depicts merchant and fishing vessels. Also dated to 1679, its drawings and appearance were similar to the two previous works. Moreover, not only did all three albums show similarities in design and style, but all three carried the arms of the Marquis de Seignelay Jean-Baptiste Colbert (1651-1690), son of the prime minister. Jean-Baptiste continued his father's work as Secretary of the Navy between 1683 and 1690. It is believed that he later had the albums bound and included his personal coat of arms.

Jean Jouve's *Deux albums des batiments del Atlantique et de la Mediterranee* of 1679 were two volumes of drawings of small ships that appeared in French harbors. Volume one addressed the Atlantic ports of Nantes, St. Gille, Sables d'Olonne, Maran, La Rochele, Port des Barques, Dans la Rivière de Seudre, Mornac sur la Riveire de Seudre, Depuis Royan, St George, Méché, Thalemont, Mortaigne, St Bonnet, A Blaye, Bordeaux,

and Bayonne. The second volume was composed of 32 drawings of Mediterranean ships.<sup>194</sup>

*Un manuel de construction de galères* was a text dating to 1691 which pertained to the construction of galleys and was not useful in the context of this study.<sup>195</sup>

Dassié's, *l'Archictecture navale* of 1695 was composed of three volumes. In the first volume the author described the general geometric principles of shipbuilding, continues with the ship's proportions and a list of 'ship's parts' for some vessel types, and in the final chapters reported lists of the officers necessary for crewing naval ships. The second volume discussed galleys and included their lists of officers. Some royal regulations were appended at the end of the second volume. The third volume addressed tides and anchorage points, the state of the kingdom's fortresses, and the status of maritime lanes.

Lafon's 1695 republication of the anonymous *Construction dès Vaisseaux du roy, et le nom de toutes les pièces qui y entrent, marquées la Table par numero: Avec tout les proportions des rangs, leur explication, les noms des vents & l'exercice du cannon.*

*Augmenté des manœuvres de Mr. De Tourville Lieutenant general des Armés Navalles ; des Traitez des Voiles, des Pavillons, & des Cordages* presented the general dimensions for all classes of royal ships, from first rate to sixth rate, and gave the specific dimensions and number of all the timbers needed to construct the vessels. The beginning of Lafon's version of this book, which was the fifth edition, included an image with

---

<sup>194</sup> Vergé-Franceschi and Rieth 2001.

<sup>195</sup> Fennis 1983.

drawings of all the timbers mentioned in the book (Fig. 27). At the end was a chapter of the naval evolutions used by Admiral Anne-Hilarion de Contentin Count of Tourville and of sails and rigging.

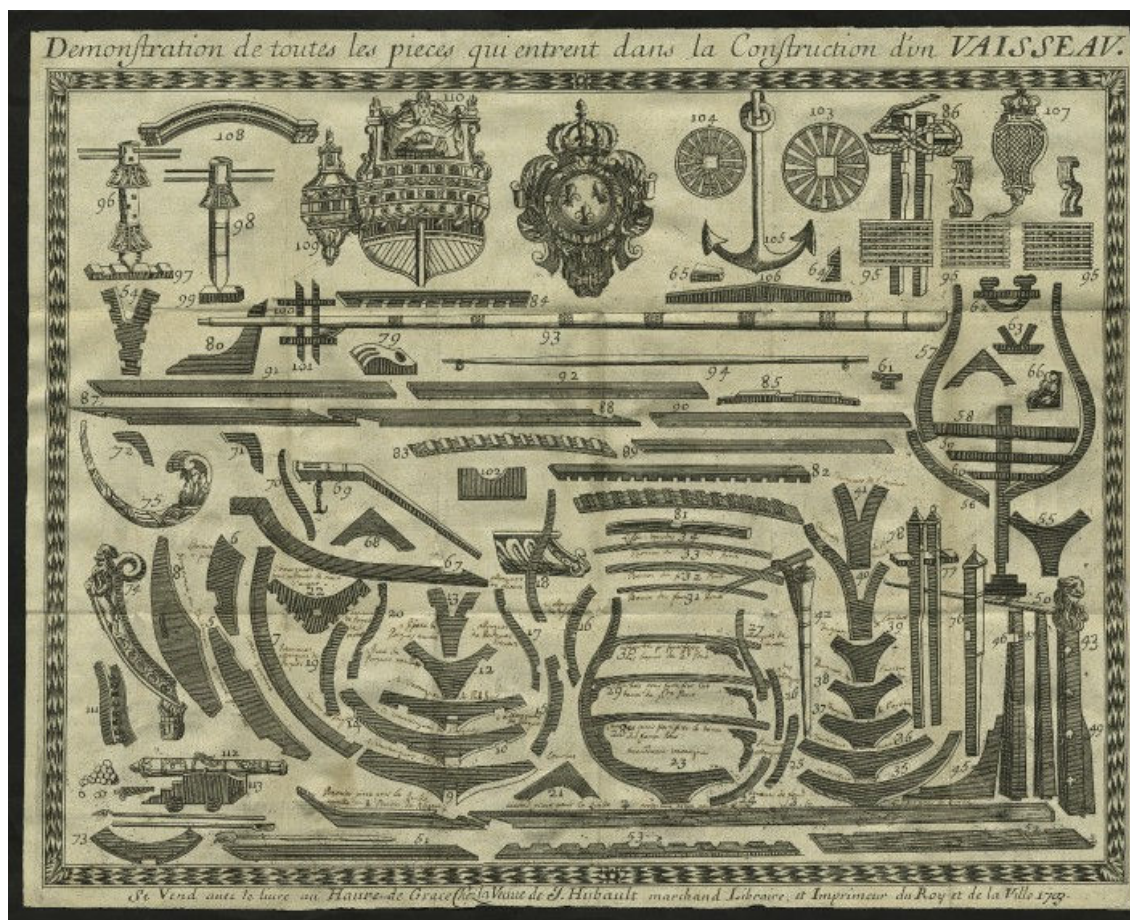

Fig. 27. Anonymous 1691 table of timbers. (Courtesy ECHO)

The king's regulations addressed the construction of several vessels and were issued in accordance with the advice and suggestions of the French Shipbuilders Council,

explained in more detail in Chapter III.<sup>196</sup> The 1670 statute only referred to light frigates and the 1671 ordinance did not discuss any frigates at all. However, in the 1673 regulation, signed by Colbert, instructions existed for a specific relation of length to breadth that must be obeyed in the construction of two-decked frigates:

Lès frégates à deux ponts auront de larguer de dehors en dehors, à l'endroit du maître bau, le quart de la longueur de l'estrave à l'estambot, sans augmentation.<sup>197</sup>

This helped identify some of the extent of French influence in Portuguese shipyards, as some dimensions and sizes are parallel to Portuguese costumes.

In sum, Dassié's work was too general to be of much use in this study and Jouve's work included only one drawing of a frigate with the information that frigates existed in the harbour of La Rochelle and seemed to have been a typical sight there (Fig. 28). More could be gleaned from the *Album de Colbert*, but it addressed a first rate ship of the line with an 80-gun battery, much larger than *Santo Antonio de Tanná*, which was probably the equivalent to a fourth rate frigate, carrying 44 to 50 guns. Lafon's *Construction of the Vaisseaux du Roi* was the best source of information of all sources available for filling the gaps in *Santo Antonio de Tanná's* scantlings list along with the regulation of 1673 which included frigates (among other ship types). Together with Laffon's the 1673

---

<sup>196</sup> Chapter III, 33-4.

<sup>197</sup> Two-decked frigates have a breadth from side to side at the master-frame one quarter of the length from the stem to the stern post without any increase.



regulation was the primary French source on frigates at the end of the seventeenth century.<sup>198</sup>

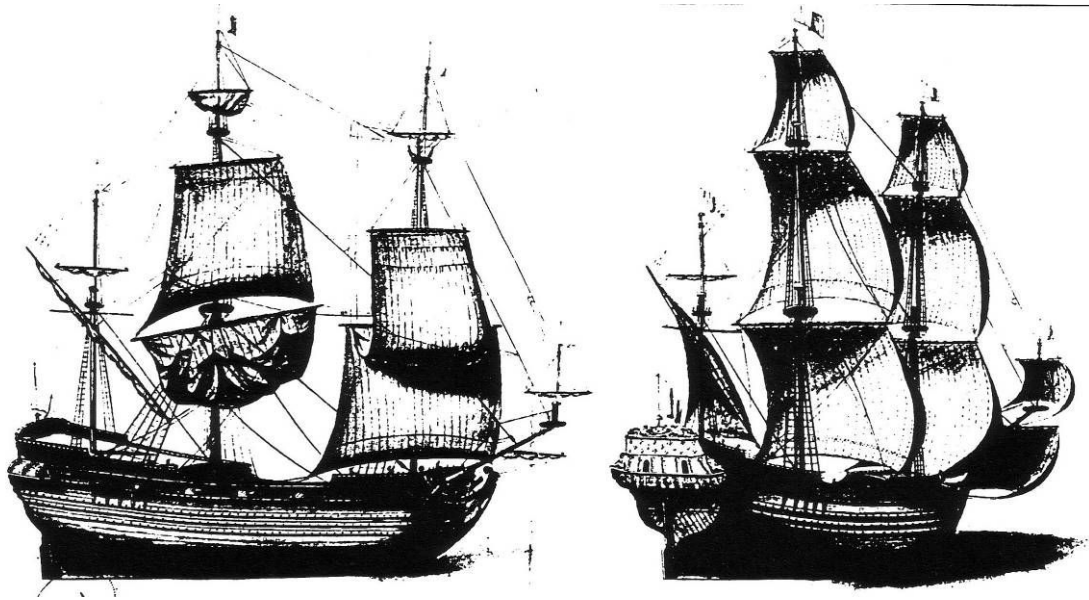

Fig. 28. Drawings of a French frigate at La Rochelle. (From Jouvé 1971, pl. 12.)

As explained in the previous chapter, the lack of definitive specifications throughout the seventeenth century for frigates as a particular ship type makes it difficult to say with certainty which documents described frigates at a particular moment in time and which did not. We can say with some certainty that as a warship type frigates evolved rapidly: those of the early seventeenth century bore little resemblance to the ones built by the end of that same century.

---

<sup>198</sup> Boudriot 1993, 16.

For this reason, the primary document sources considered most pertinent for the reconstruction of *Santo Antonio de Tanná* were:

- a) Two of the lists of dimensions for Portuguese frigates from the 1692 *regimentos* sent to India;
- b) The scantling list from the *Relação dos Nomes das peças da Construção dos Navios e das madeiras do Brasil próprias para elas*;
- c) The two frigates described in Gazstaneta's *Arte de fabricar reales*;
- d) The *Album de Colbert*, even considering that it precedes the construction of *Santo Antonio de Tanná* by 11 years and pertains to the construction of a first-rate ship;
- e) Lafon's *Construction de Vaissaux du Roy*, as it is the only complete manuscript that gives information on the specific timbers that composed a ship;
- f) The 1673 French legislation, because it may have influenced Portuguese construction, either directly or indirectly, through the English as they seized and tried to copy French ships during this period;<sup>199</sup> and

---

<sup>199</sup> Woodman 1997, 77; see also Winfield 1997, 9,28; see also Lavery 1983a, 18,32,37-8.

g) *Deane's Doctrine of Naval Architecture*, while it also precedes the construction of *Santo Antonio de Tanná* by 11 years, there were close relations between Portugal and England at the end of the seventeenth century;

Naturally, not only written documents were considered as historical sources in this reconstruction. Iconography also played an important role; for instance, Figure 27 presented in this chapter is an important iconographic source. Together with contemporary iconography was analyzed and used to help in reconstructing *Santo Antonio de Tanná*. Relevant images and ship models are discussed in the next chapter.

## CHAPTER VII

### ICONOGRAPHIC SOURCES FOR RECONSTRUCTION

Aside from the available textual sources, iconographic representations offer further clues for determining the appearance of a late seventeenth century frigate. Since this type of ship not only evolved rapidly, but also varied from country to country up to the eighteenth century, iconography helped target the specific details of a frigate at the end of the seventeenth century. Three types of iconographic representations were available:

- a) Artistic renderings of vessels;
- b) Technical drawings;
- c) Models.

Artistic renderings are an uncertain source of information if one does not know how reliable his the artist who produced the image. The most realistic drawings of this period are Flemish and Dutch.<sup>200</sup> The quality of both drawings and paintings by Willem van de Velde the Elder (1611-1693), Willem van de Velde the Younger (1633-1707) and Jan Porcellis (1584-1632) are well-known. Other northern artists, such as Sebastian de Castro and Jacob de Gruyter painted realistic views of southern Europe ships, making them a valuable source of information.<sup>201</sup>

---

<sup>200</sup> Goedde 1989,5.

<sup>201</sup> Archibald 1989, 92, 127, 174, 219-20, 253; see also Catalogue 1997.

Unfortunately there are almost no known representations of Portuguese ships of the late seventeenth century. Many Portuguese archives, palaces, and libraries were destroyed in the 1755 earthquake that hit Lisbon or by the fires that consumed the city in the following weeks.

Technical drawings may have originated from within shipbuilding treatises, such as those of Gazstafñeta Yturribalzaga; others were made for shipyard use and are to be found in museums or private collections (the Keltridge Drawings in the National Maritime Museum in England are an example of this).

Contemporary ship models are another valuable source. Some models were prepared for practical shipyard use, others to explain ideas to politicians and other influential persons, and others simply as displays. Sometimes, models were requested by the nobility and clergymen as gifts or for display, mostly when the ships became famous.

Drawings already presented in this study include Dudley's Dunkirker and Fernandez' *Patacho Holandez*, and they showed the probable ancestors of the late seventeenth century frigates (Fig. 29).<sup>202</sup>

---

<sup>202</sup> See also figure 14 in Chapter III, 32.

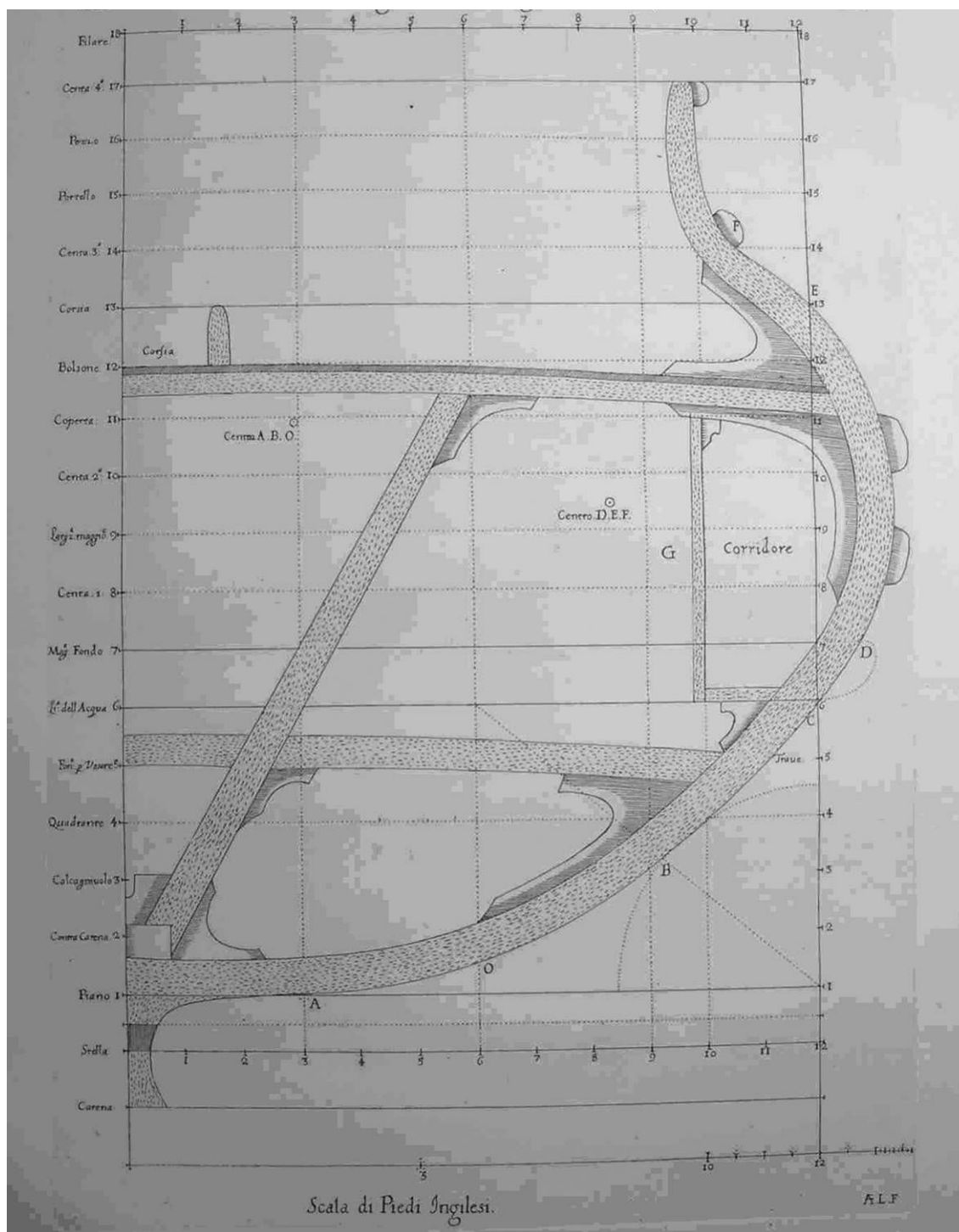

Fig. 29. Robert Dudley Dunkirk-ship midsection. (After Dudleo 1616, pl. 12)

More generic drawings existed in the Bushnell and Deane treatises. These were good references for understanding the common features of these ships (Fig. 30 and Fig. 31).

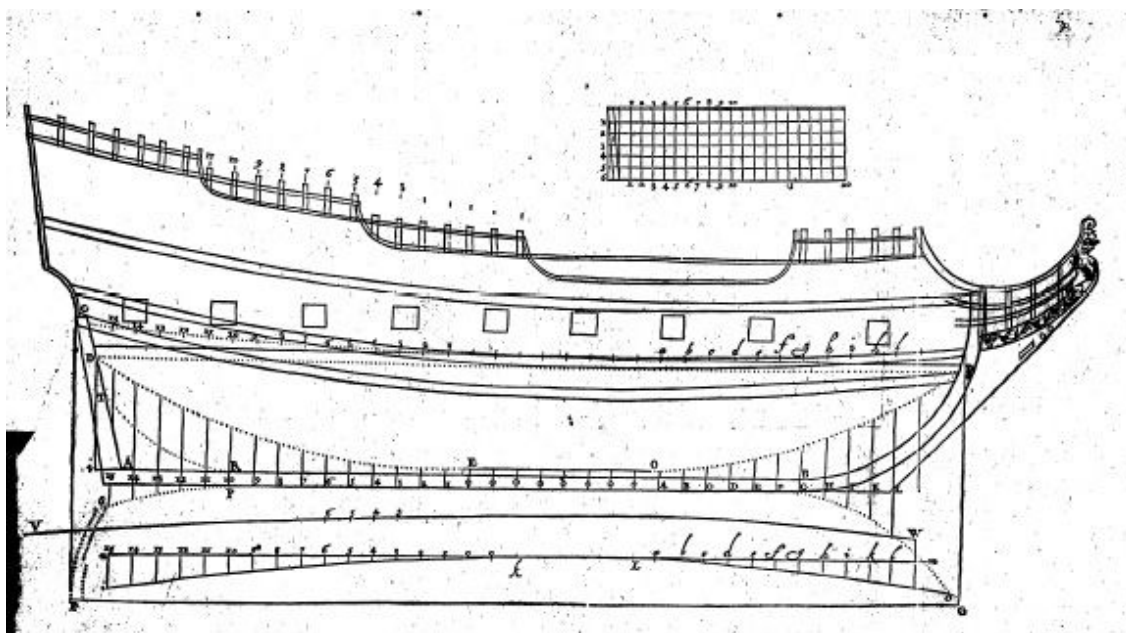

Fig. 30. Bushnell drawing. (1669, 8v)

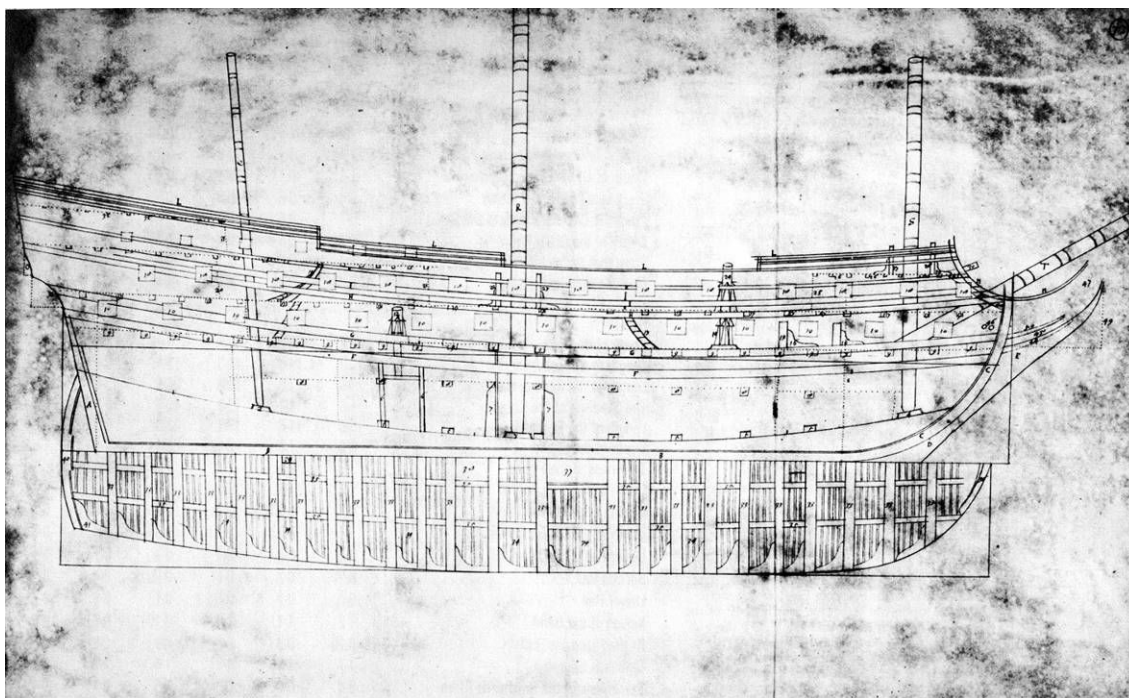

Fig. 31. Deanes drawing. (After Lavery 1981, 75)

Approaching the time span of *Santo Antonio de Tanna* construction some important drawings were found. The first was published by Jean Boudriot.<sup>203</sup> Located in the collections of the Musée de la Marine, this 1686 drawing presented a 42-gun frigate (Fig. 32). Penned by P. Chaillé, a shipbuilder in Le Havre shipyards, this drawing showed the frigate in three views. The sheer plan depicted the frigate above the water line with the positions of the masts and gunports. The half-breadth plan showed the waterlines and the arrangement of the weather deck. Shown in the contemporary manner that passed out of use in the eighteenth century, it represented the framing of the vessel superimposed on

---

<sup>203</sup> Boudriot 1993, 27.



the sheer view. The 1686 Chaillé plan of the 42-gun frigate was especially significant for two reasons: first, because it was contemporary with *Santo Antonio de Tanná*, and second because it was of a very similar type.

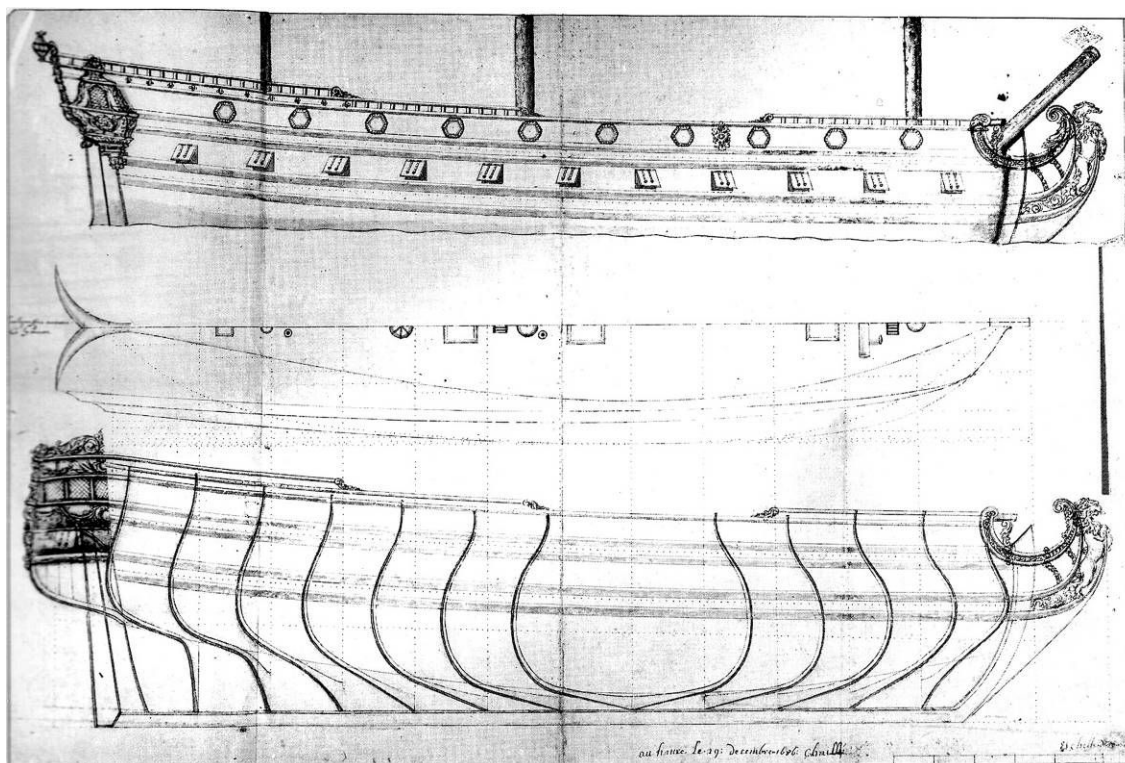

Fig. 32. P. Chaillé 42-Gun Frigate. (After Boudriot 1993, 27)

Other available drawings close to what *Santo Antonio de Tanná* might have been come from the archives of the National Maritime Museum. Made by English shipbuilder William Keltridge between 1680 and 1685 they were known as the Keltridge Drawings. They presented several comparisons of designs between the old style and the new style

of ship building and are considered the earliest scientific drawings produced in England.<sup>204</sup> They consisted of fourth, fifth and sixth rate ships. Relevant to this thesis were the complete lines drawings of a 42-gun frigate and a schematic of a master frame with tables of dimensions for two fourth rates, one fifth rate and two sixth rates.

The line drawings represented a fourth rate in all three views. Two body plans were included, one showing the stern together with its richly decorated transom panel, the other showing the sections of the bow. These sections were spaced three feet apart, totaling 49 sections. The sheer plan depicted three diagonals and showed the completed hull from the load waterline upwards. The sheer view depicted the waterlines. The amount of information derived from these lines drawings made them extremely useful for the reconstruction of *Santo Antonio de Tanná*.

The schematic of a master frame is divided into two sections. On the right, the first section depicted a table that expresses several weights. First, the cubic feet area of each rate was displayed; then, the weight of each rate's hull upon launching. Following that was the amount of victuals needed to sustain the crew. It continued with the weights of the rigging, the ordnance, and the crew luggage, among other details. Portrayed on the left, the second section was a cut of the amidships section. It displayed the timbers required to assemble the frames and the type of guns the ship was intended to carry.

---

<sup>204</sup> National Maritime Museum 2004, 1 November *Ship Plans*. <http://www.nmm.ac.uk/site/request/setTemplate:singlecontent/contentTypeA/conWebDoc/contentId/238/navId/005002000> (11 November 2004).

Henry Culver's book *Contemporary Scale Models of Vessels of the Seventeenth Century* (1954) presented the third iconographic source of information.<sup>205</sup> In his work, Culver photographed and commented on several models, thirteen of which are either fourth rates or 50-gun ships. John Franklin's book *Navy Board Ship Models* expanded on the available information about the models.<sup>206</sup> All help to shed a little more light on the design of a frigate (Fig. 33 to Fig. 45).



Fig. 33. A model of a 44-gun fourth rate. Its name is unknown but it bears the inscription "Bristol 1666". (From Culver 1954, 9)

---

<sup>205</sup> Culver 1954.

<sup>206</sup> Franklin 1989.

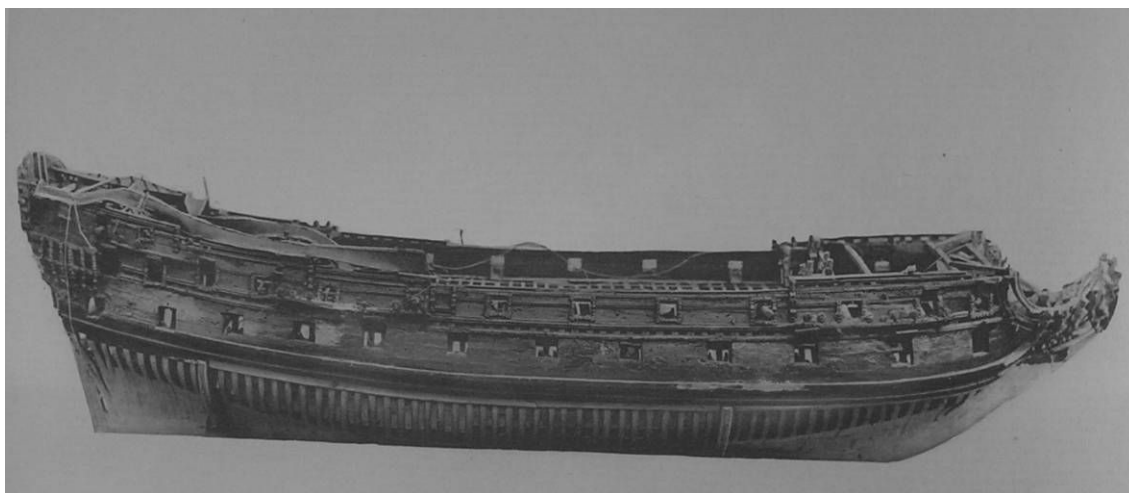

Fig. 34. Fifty-gun warship dated to the 1650s of English design. The model is in bad shape. Notice the scarcity of deck beams on the forecastle. (From Culver 1954, 10)

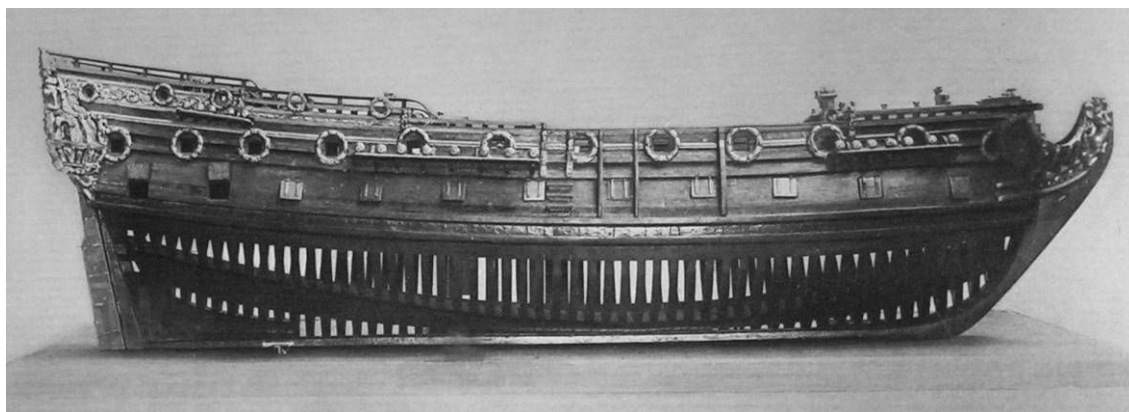

Fig. 35. The model of the *Mordaunt*, a fourth-rate warship built in 1681 at Deptford. Franklin (1989, 94) notes that was originally built as heavy armed privateer. The channels give the location of the masts. (From Culver 1954, 21)



Fig.36. An unknown 50-gun warship. (From Culver 1954, 23)

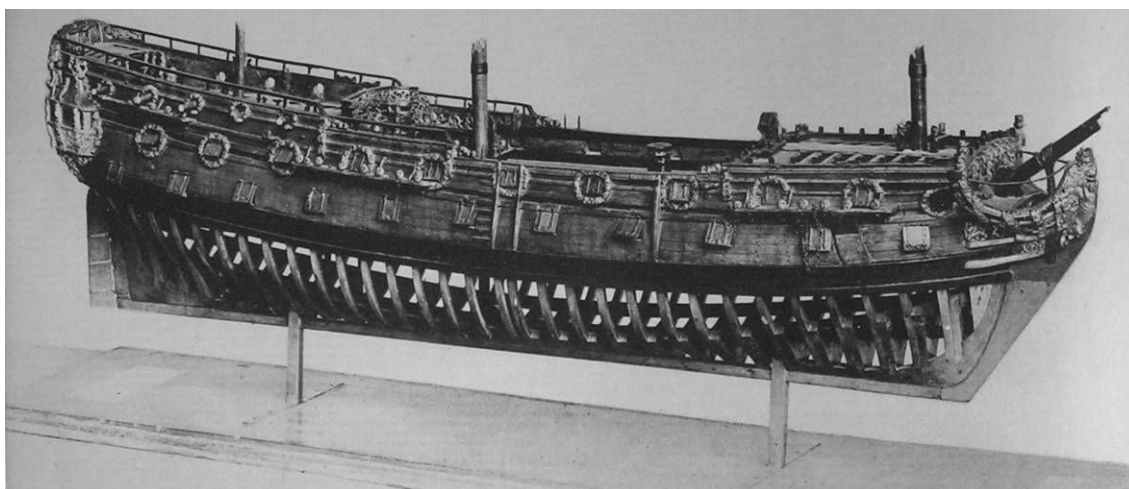

Fig. 37. Scale model of a 50-gun warship from 1685. The framing of this model is clearly not intended to represent the actual pattern of framing the hull (too far apart). Another interesting feature is the heavy gilding of the stern castle. (From Culver 1954, 24)

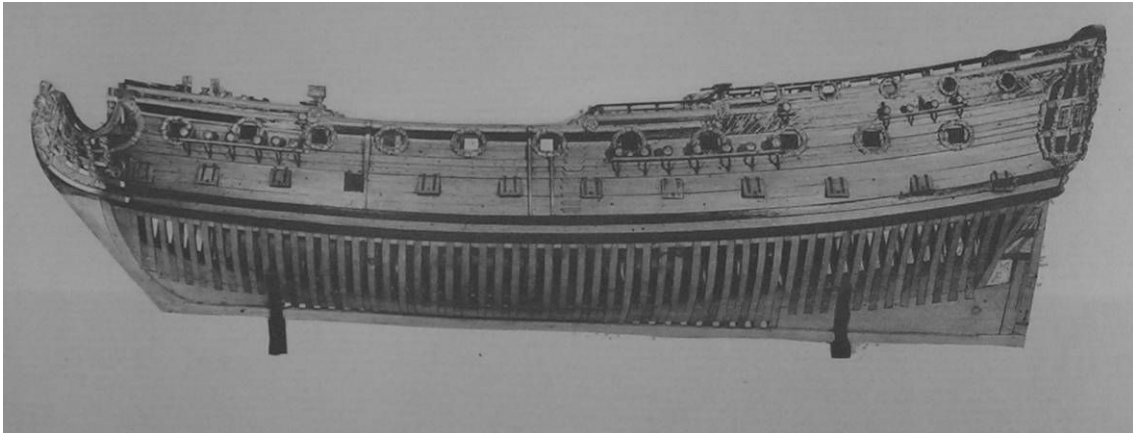

Fig. 38. Unidentified fourth rate of the last quarter of the seventeenth century. Notice the pronounced slope of the stern, a signature feature of English warships in the eighteenth century. (From Culver 1954, 28)

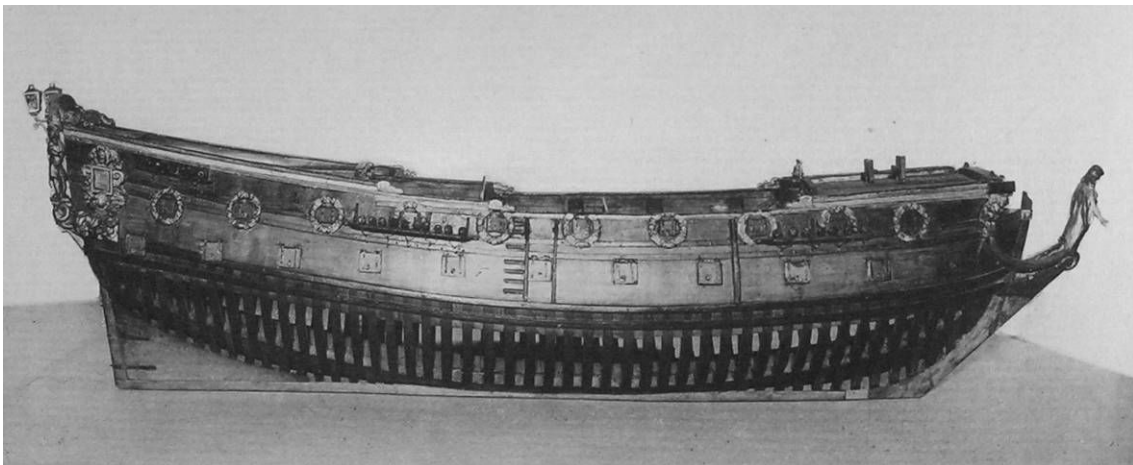

Fig. 39. Unidentified 44-gun warship dated from the last decade of the seventeenth century. Notice the long rake of the stem, which is more commonly used in the first half of the seventeenth century. (From Culver 1954, 35)

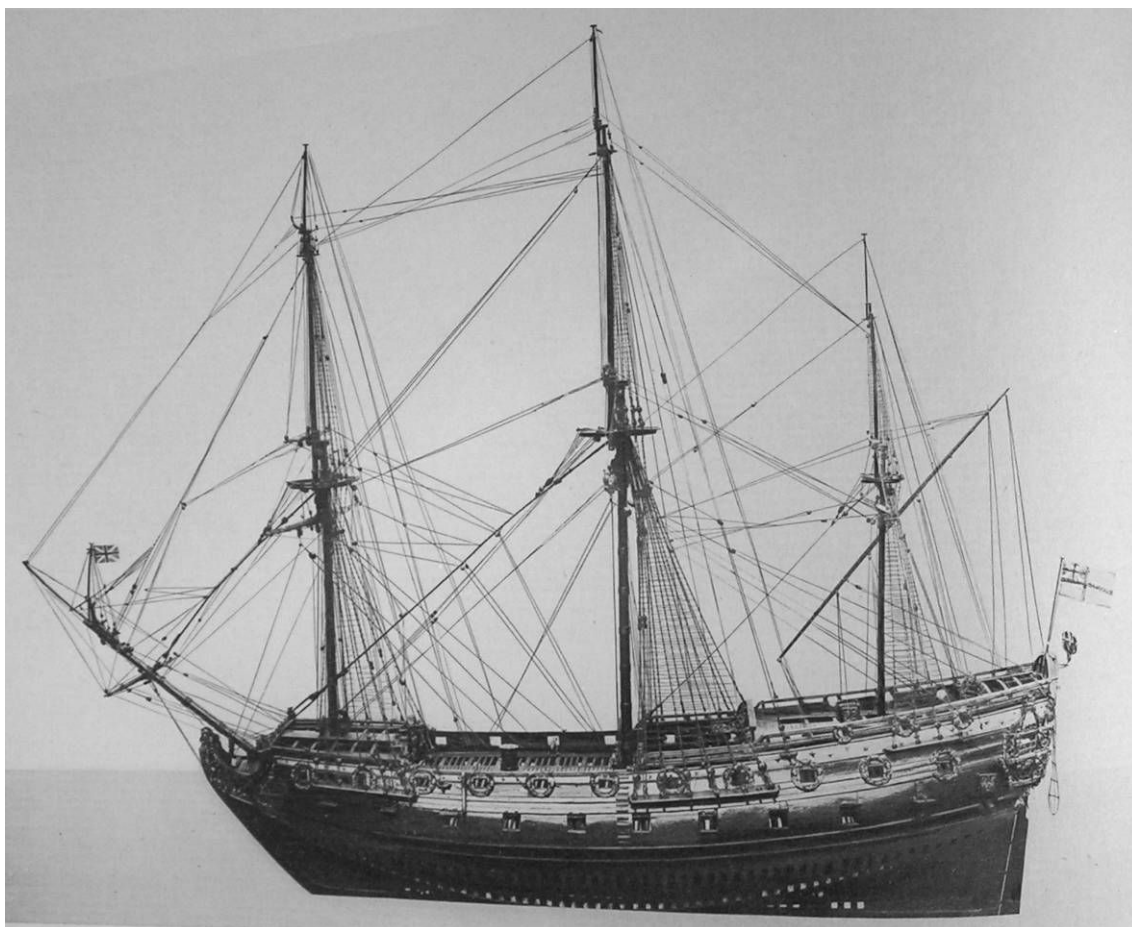

Fig. 40. Unidentified English 50-gun warship dated to the last decade of the seventeenth century. Although this model is complete with masts and rigging, Culver was of the opinion that the rig dates to a later period. (From Culver 1954, 33)



Fig. 41. Unidentified fourth rate 48-gun warship. The rigging seems to be contemporary with the hull. Notice the framing on top of the stern castle for a canvas awning. (From Culver 1954, 36)



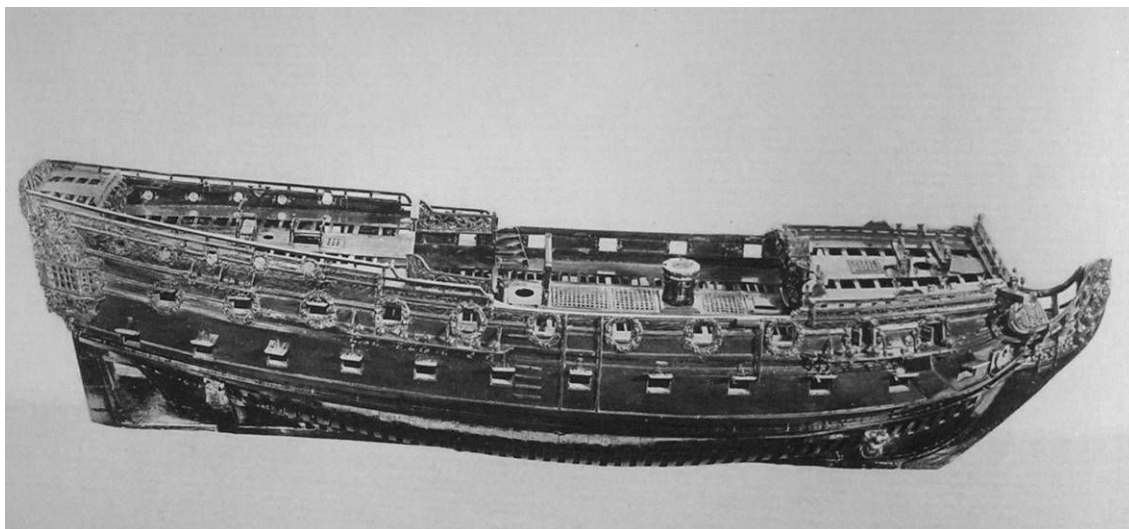

Fig. 42. Warship pierced for 46 guns. Culver titles it the *Boyne*, but refers to it as an 80-gun warship; the paragraph got misplaced, Franklin's work (1989, 111-5) shows the correct model for Boyne. The rake of the stem seems to correspond to the first quarter of the seventeenth century, but the rest of the hull looks of latter date. (From Culver 1954, 39)

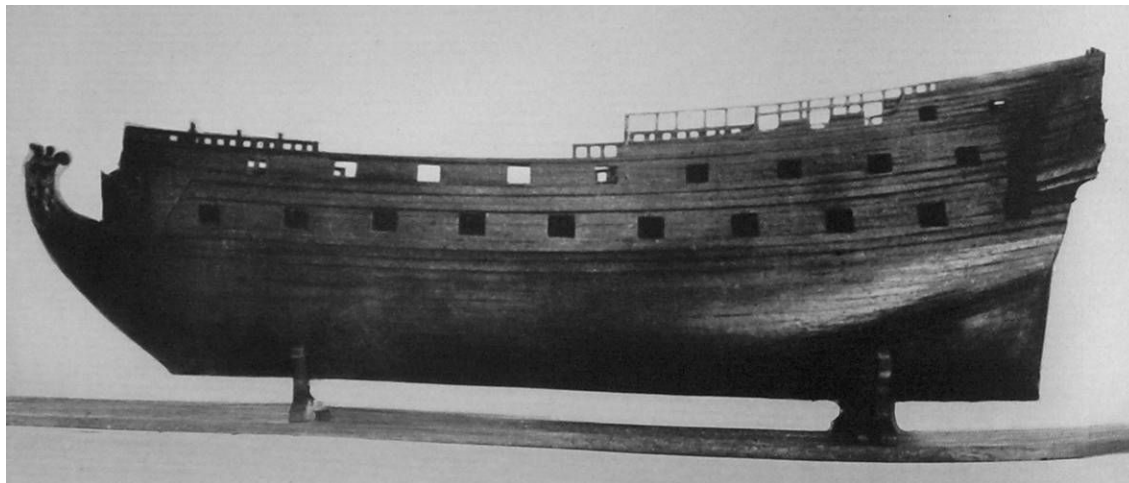

Fig. 43. *Prins Carl* a Danish 50-gun warship, launched at Nyholm 15 October 1696. This model was damaged during a fire at the dockyards in 1795. (From Culver 1954, 42)

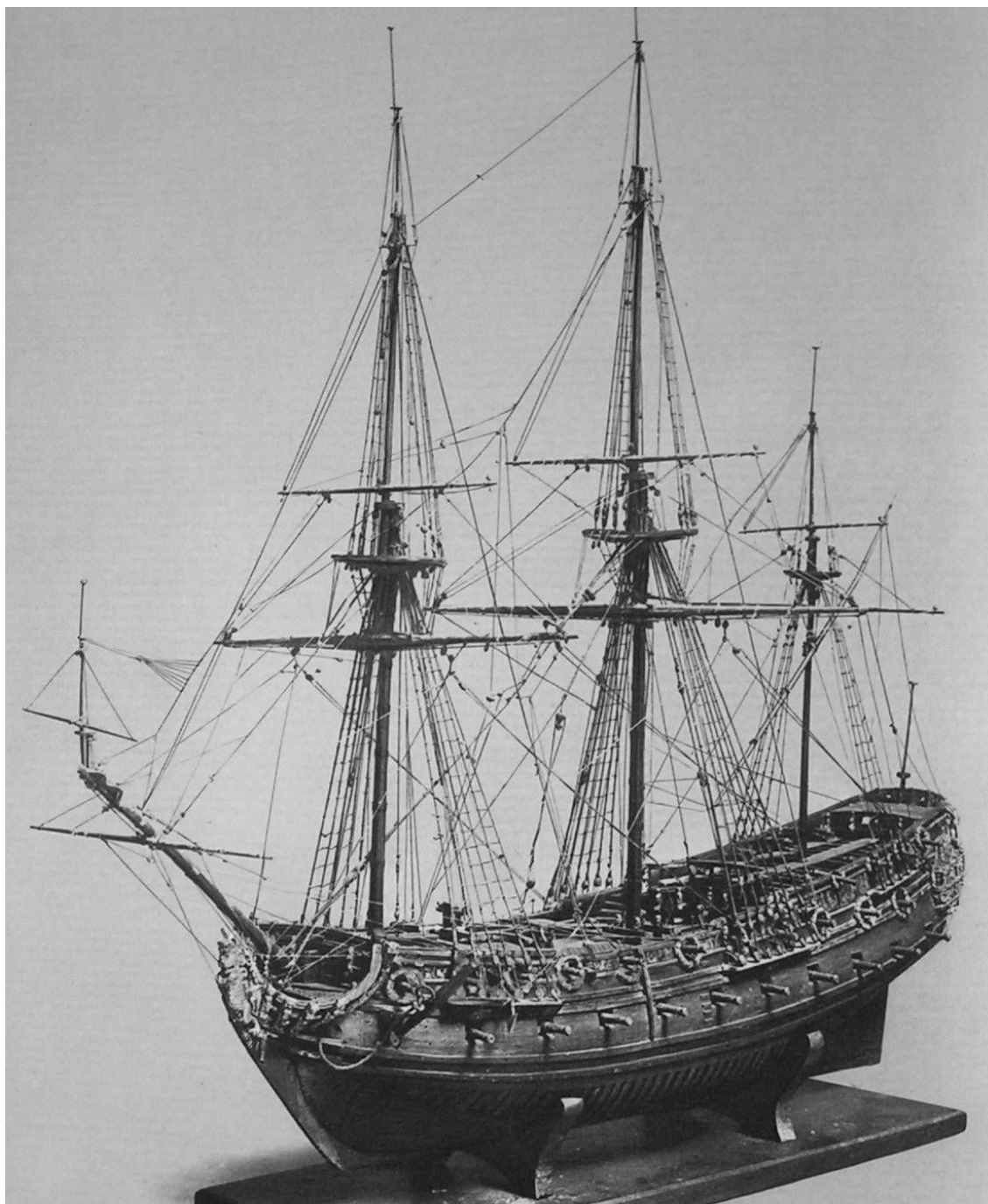

Fig. 44. Fourth rate English warship of 52 guns. This is again a fully rigged model dated to 1695. Culver believes that the rigging is of later date. Dr. Kevin Crisman disagrees (personal communication September 2007). (From Culver 1954, 41)

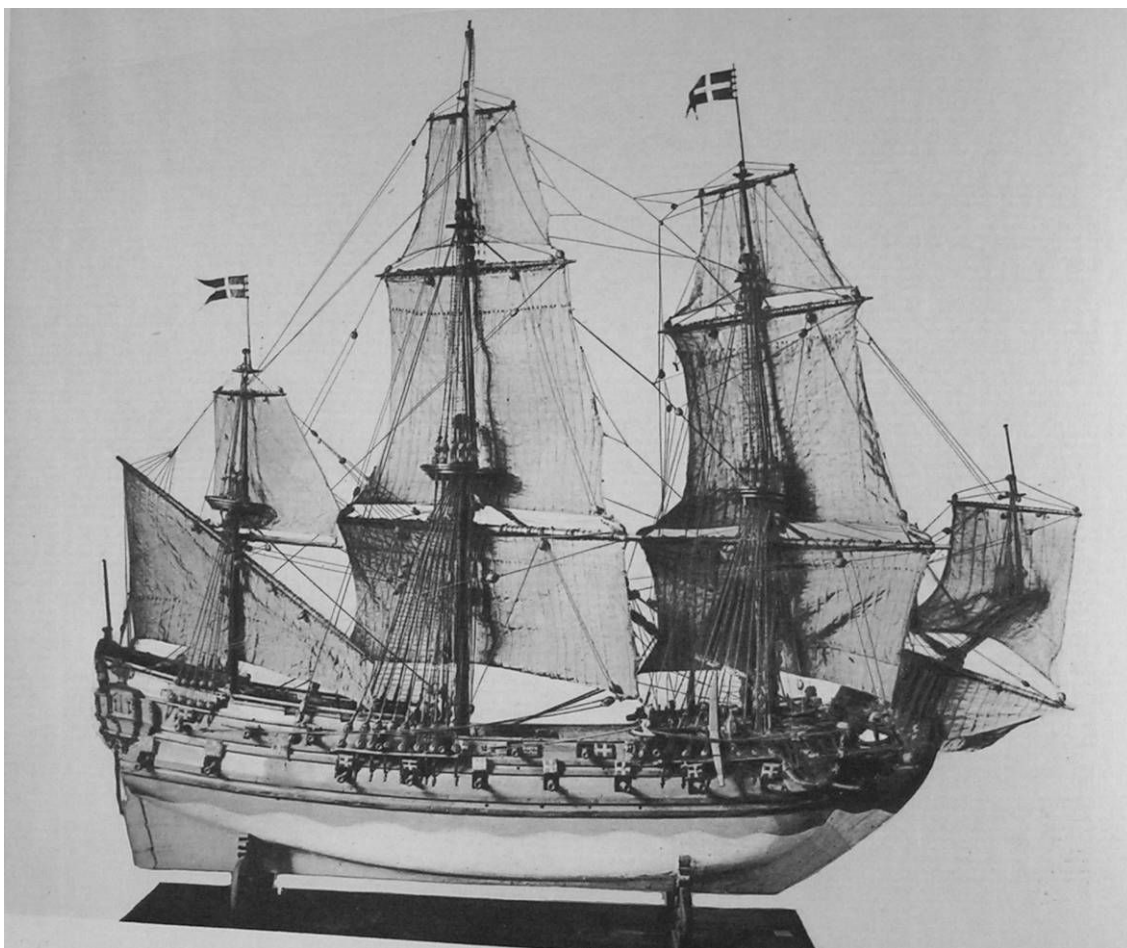

Fig. 45. Danish warship of 50 to 54 guns built in the last years of the seventeenth century. R.C. Anderson states the hull of the model's accuracy is doubtful. However, it is included because it is the only model in which the rigging is considered accurate. (From Culver 1954, 46)

The models gave a good idea of how some European vessels looked, especially English frigates contemporary with *Santo Antonio de Tanná*.

However politically and culturally apart Portugal may have been from its Iberian neighbor Spain, it is likely that they exchanged ideas when it came to naval design and construction. The sketches of Gazstañeta Yturribalzaga's treatise were also considered in

the reconstruction of *Santo Antonio de Tanná*. The drawing of the 90 - gun warship *Nuestra Señora de la Concepción y Las Animas* depicted the appearance of a Spanish stern (Fig. 46 and Fig. 47). However, the most important sketch is of a *Fragata Grande*, armed with 26 guns. It showed the Spanish design preferences for these types of ships (Fig. 48).

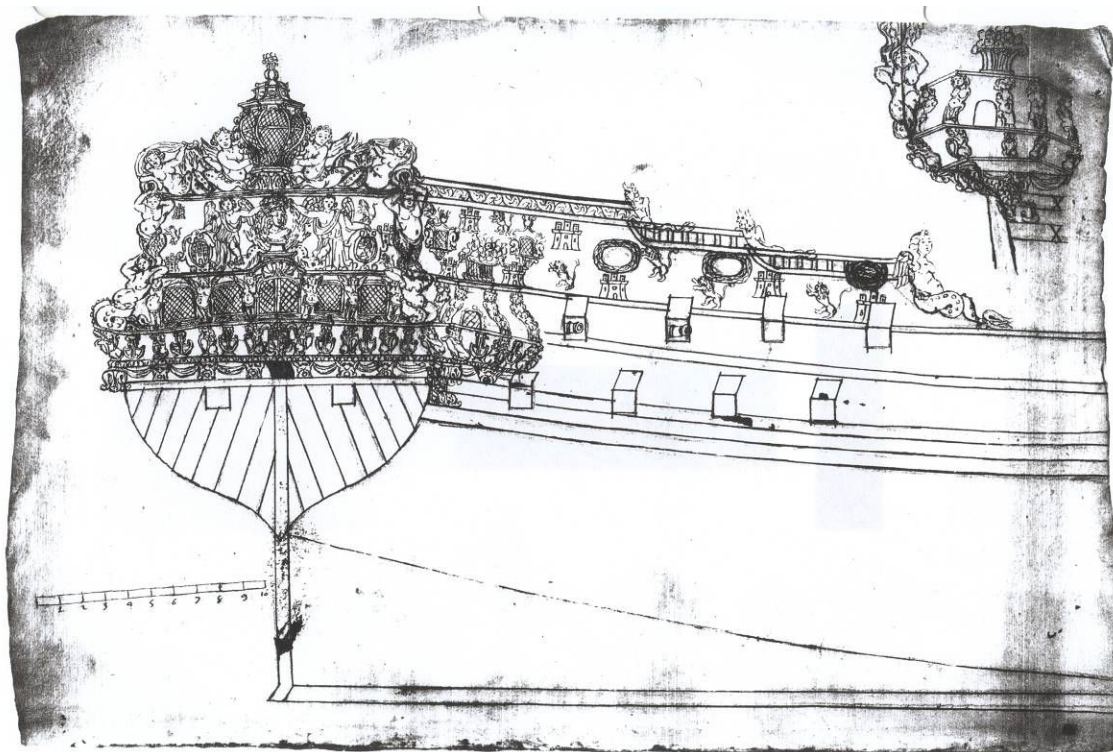

Fig. 46. The stern of *Nuestra Señora de la Concepción y Las Animas*. Notice that the curve of the wales and the sheer are less pronounced than in English ships. (After Gonzales et al. 1992, 2:71)

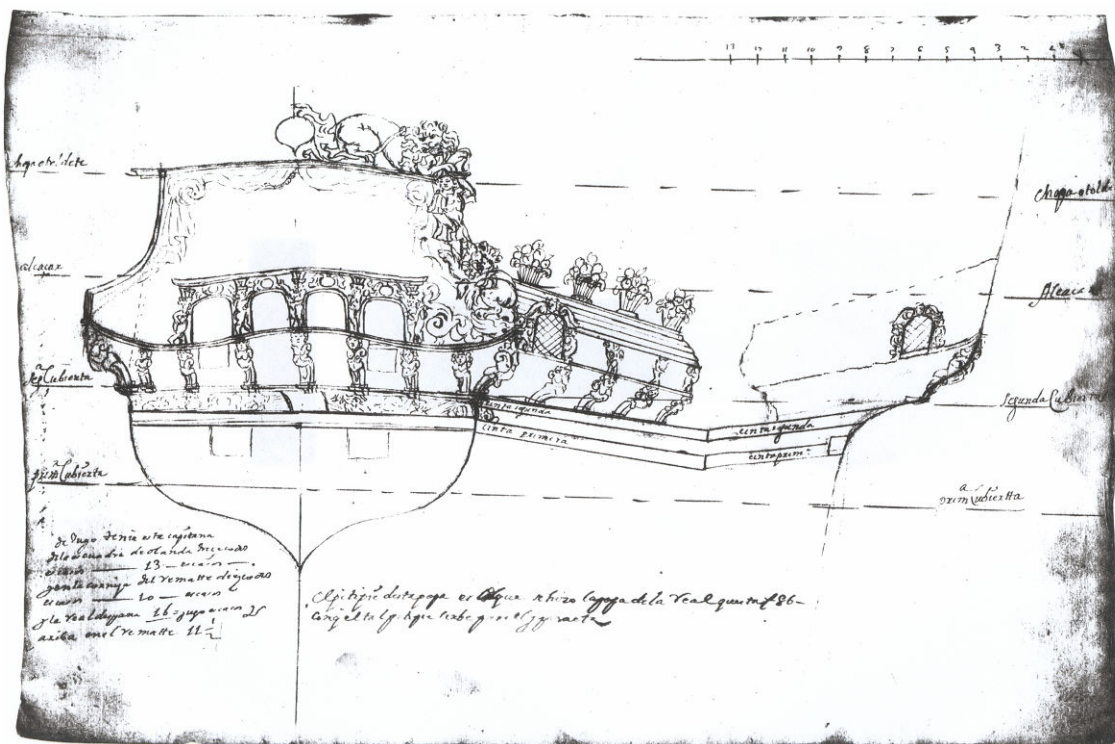

Fig. 47. Detail of the stern of *Nuestra Señora de la Concepción y Las Animas*; the text on the corner details the deck heights. (After Gonzales et al. 1992, 2:72)

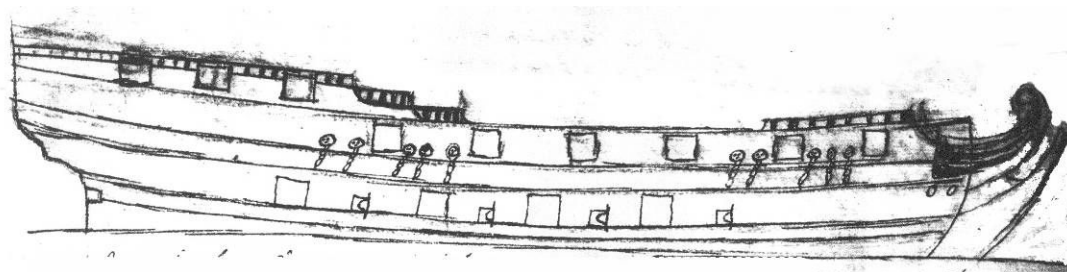

Fig. 48. The profile view of a 26-gun frigate. (After Gonzales et al. 1992, 2:219)

This collection of iconographic sources provided access to some of the general characteristics of these vessels: their gun arrangements, mast positions, and some rigging

information. They also showed, mostly in the case of the models, the general shape of the hull and, in the case of the technical drawings, the general shape of the sections and information about other lines. These data provided information required for the reconstruction of *Santo Antonio de Tanná*. With a hypothesis determining the shape of the hull, and a tentative scantling list derived from written treatises, the reconstruction could have started to advance to the next stage. However, knowing the names and numbers of the components that composed the vessel was not enough; the shape and size of these components also had to be derived. The best available source on individual components was Lafon's *Construction des Vaisseaux du Roy*. The print presented by Lafon in his work encompassed all the components required to build a ship and was of great importance to understanding the shape and style of the timbers mentioned in historical sources.<sup>207</sup>

Yet another question to be addressed was the construction sequence of a ship like *Santo Antonio de Tanná* at the end of the seventeenth century. How did the assembly proceed? What was the order of assembly, and how would shipyards address the technical issues of placement? *Colbert's Album* was the best source to answer these questions. Although the plates in Colbert's treatise showed the construction sequence of a much larger first rate, we know that ship construction for all rates was becoming standardized, and thus it can be assumed that many of the same components existed on a fourth rate. Similarly, the assembly order represented in Colbert's first rate would be along the same lines for a

---

<sup>207</sup> Figure 27 in Chapter VI, 95.

fourth rate, except that fewer decks existed in a fourth rate and that same components might be proportionately larger. In any event, all plates were used to understand the construction sequence. To represent all the plates in Colbert's treatise would be beyond the scope of this thesis and therefore only three are depicted here.<sup>208</sup> The first plate shows the ship built up to its third futtocks (Fig. 49). *Santo Antonio de Tanná* would have looked similar in the shipyards. However, in contrast to Colbert's first rate which has more decks, *Santo Antonio de Tanná* had only two decks, so no more futtocks would be have been added. The second plate presents the ship's deck beams (Fig. 50). Since *Santo Antonio de Tanná* deck beams did not survive, this plate helped to illustrate the deck beam configuration, although it is known that English and French shipbuilders built the decks structures of their ships differently.<sup>209</sup> The third image depicts the cross-section of the first rate (Fig. 51). One of the reconstruction's more difficult tasks was to understand the internal arrangements of the Portuguese frigate; this cross-section provided some clues.

---

<sup>208</sup> For a full analysis and to view all of the *Album of Colbert* plates, Vergé-Franceschi M. and E. Rieth present an excellent discussion of Jouvé and Colbert in their book (2001).

<sup>209</sup> Although the arrangement of the beams for the Portuguese built ships could have been influenced by either English or French, the assembly of the beams was different because the Portuguese used vertical and horizontal knees to support and set the beams in place.

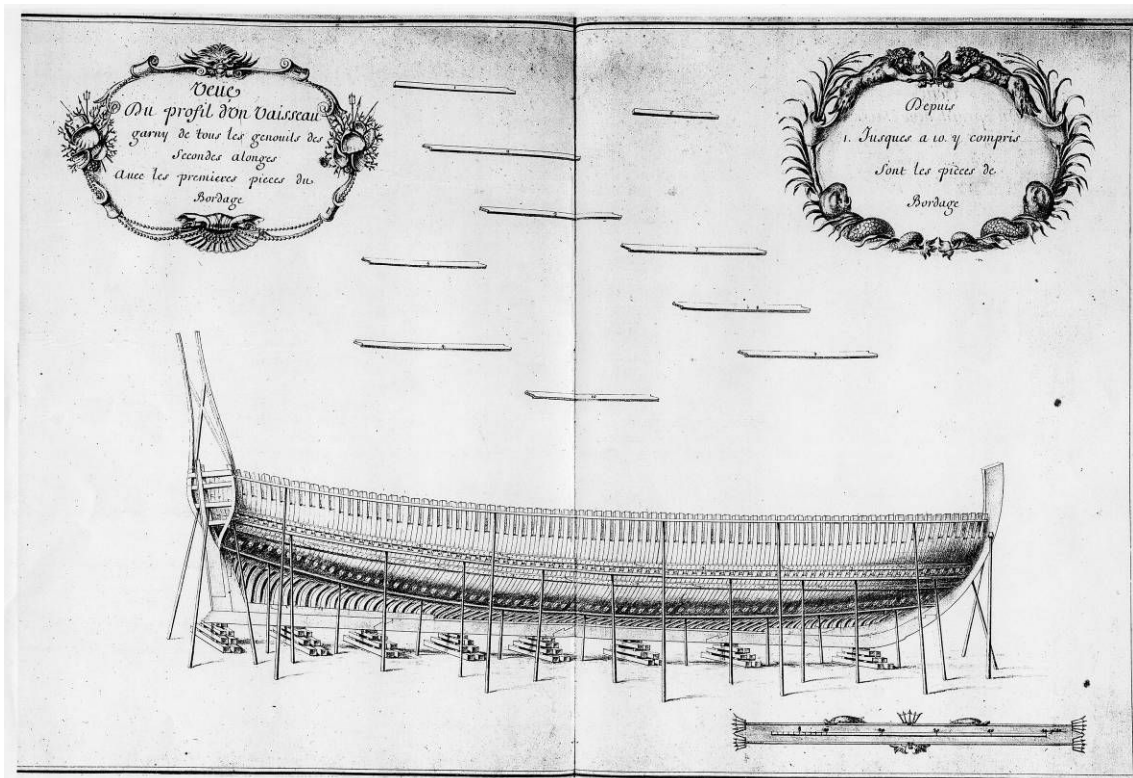

Fig. 49. *Album de Colbert* Plate 12. (From Anonymous 1988, pl. 12)



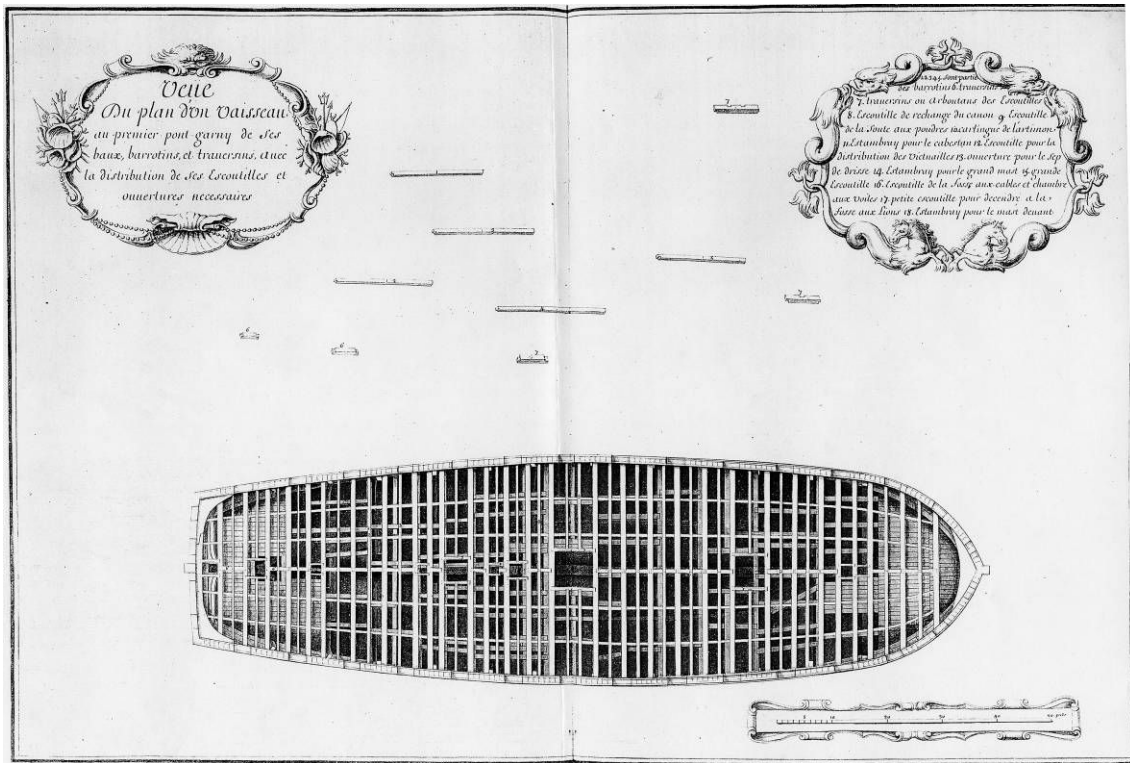

Fig. 50. *Album de Colbert* Plate 19. (From Anonymous 1988, pl. 19)

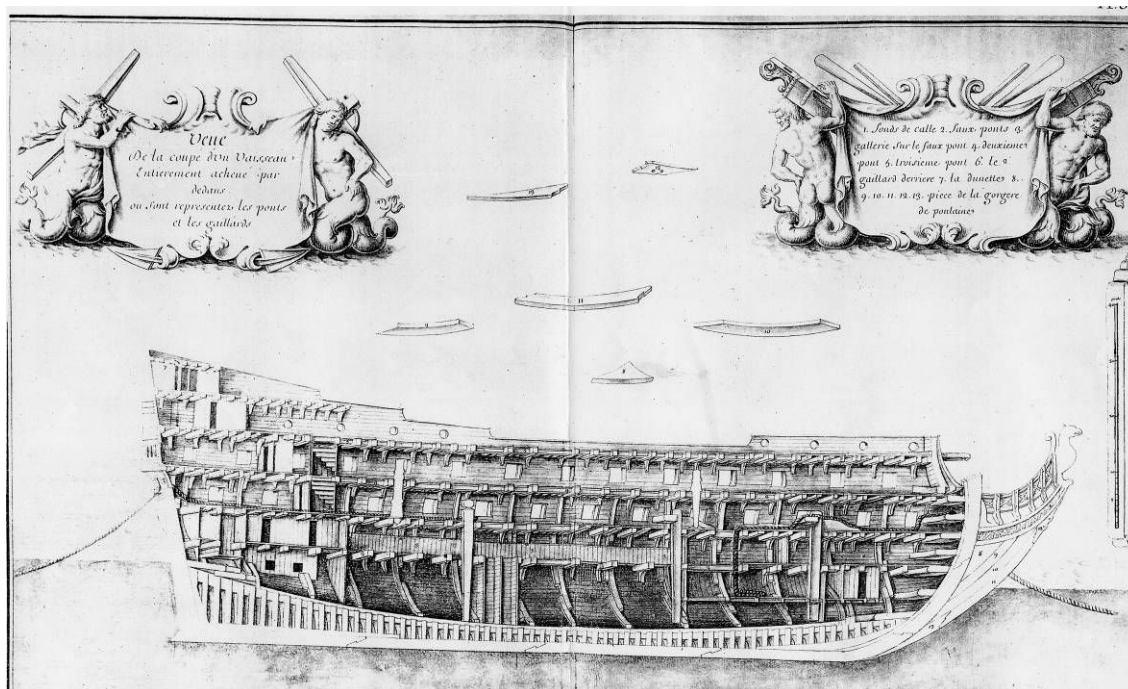

Fig. 51. *Album de Colbert* Plate 37. (From Anonymous 1988, pl. 37)

The iconography that accompanied these treatises and the drawings from the last quarter of the seventeenth century were valuable tools for the reconstruction of *Santo Antonio de Tanná*. This collection helped fill several gaps in the knowledge of Portuguese frigate shipbuilding, or at least permitted an educated guess on the questions that arise in the reconstruction of a ship. Again, it is unfortunate that almost no Portuguese sources have survived to demonstrate the national preferences that undoubtedly were present in *Santo Antonio de Tanná*. Some arrangements in the reconstruction results came not from historical sources or archaeological ones, but from 'best guess' preferences of the author. However, before proceeding to the reconstruction, the next chapter presents the last and most crucial source, the archaeological remains of *Santo Antonio de Tanná*.

## CHAPTER VIII

### ARCHAEOLOGICAL REMAINS

As important as the written and iconographic sources were, they could not replace the most important single source of information, the ship itself. This chapter presents the information ascertained from the surviving remains of *Santo Antonio de Tanná*.

#### Surviving hull remains

The first part of an archaeological reconstruction of a ship comes from the information and scantlings inferred from the hull remains. The hull remains, in the case of *Santo Antonio de Tanná*, lay on a site 33 m in length by 12 m in breadth and were composed of more than 200 pieces of timber (Fig. 52). This considerable portion of the ship was instrumental in understanding how the ship was built. The ship itself ended up resting on its port side, which survives almost up to the gun deck. The starboard side was preserved to the turn of the bilge along the first stringer. At the after end of the area, the base of sternpost survived, giving an indication of the appearance of that part of the ship. The stem did not survive.

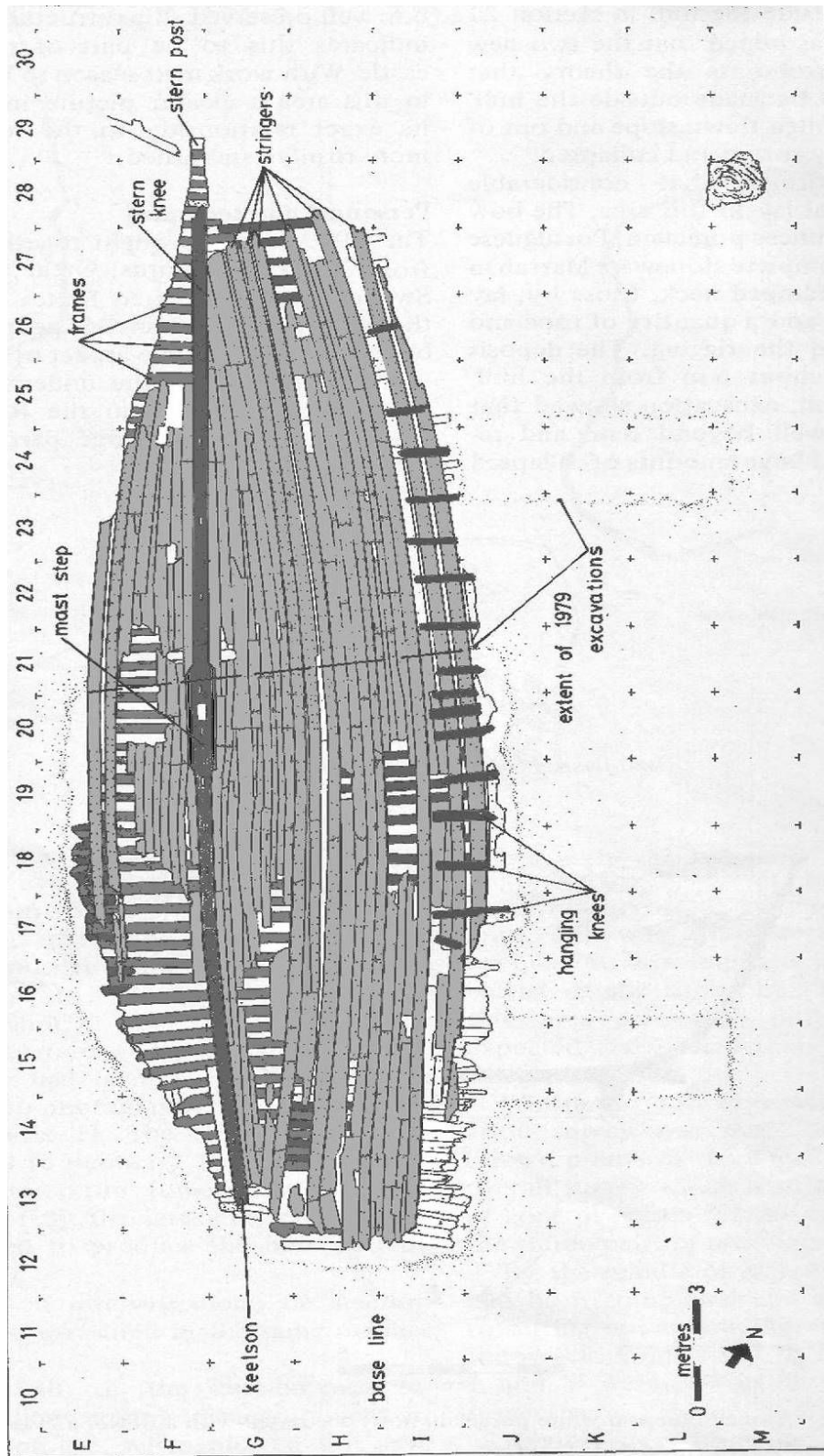

Fig. 52. Plan of the 1979 excavation. (After Piercy 1979, 306)

The team that excavated *Santo Antonio de Tanná* planned to partly disassemble the ship's structure, but time constraints and a change of politics regarding the team's presence in Mombasa did not allow for the completion of the excavation. For those reasons no detailed drawings of the timbers exist. The retrieval of several surviving key features of *Santo Antonio de Tanná* would have served as an excellent platform for the study of Portuguese frigates. The incomplete nature of the hull recording means that the work done in this thesis must be considered an approximation of the frigate. To permanently close the chapter on the ship reconstruction would require a complete re-excavation of the hull remains. The primary basis for this work is a full photomosaic of the hull and a number of profile sections taken on the upper surface of the ceiling planking. Sparse as they were, these data provided the foundation for reconstruction of the hull of *Santo Antonio de Tanná*.

#### Information for the line drawings

As stated above, the bases for this work were the photomosaic and profile sections. The profile sections started at the maststep and were taken every meter towards the stern in 1977 and similarly towards the stem in 1978.<sup>416</sup> These sections were based on the interior face of the ceiling planking and do not have detailed information about the timbers below the ceiling. The lack of frame dimensions, assembly patterns and sections taken to the exterior faces of the frames greatly handicapped the reconstruction work.

---

<sup>416</sup> Green 1991, 9.

In this reconstruction the section lines, normally based on the exterior surface of the frames, had to be inferred from the sections taken from the interior of the ceiling. The main obstacle of this approach was the ceiling curvature, which inevitably will be different from the curve of the exterior frame faces. This is due to several factors including variations in the thickness of the ceiling planking, the difference in shape between the interior face and the exterior face of the frames, and the fact that the narrowing of the upper frames is invisible on the ceiling sections. Even if the recorded sections are not ideal for reconstruction purposes, the sections taken on the ceiling did serve as an approximation of the ship's real lines and serve as a basis for all the remaining drawings.

### Measurements

Although Portugal presently uses the metric system, in the seventeenth century the Portuguese used a different system of measurement for nautical matters. The main unit was the *rumo*, which was divided into six *palmas de Goa* and each *palmo de Goa* in ten *polegadas*. This system was stated clearly on the letter of the King to the Vice-Roy of the East Indies, explained in detail in chapter VI.

*Declaro que todos estes palmos hão de ser de Goa, que tem dez polegadas cada um e cada rumo tem seis palmos de Goa [...]*<sup>417</sup>

---

<sup>417</sup> I declare that all these palms will be of *Goa*, which has ten inches each and each *rumo* has six palms of *Goa* [...]. (Pona 1890 218-9)

Regarding the metric equivalent of a *rumo*, according to Oliveira's *Livro da Fabrica das naus* in 1570:

*A terceira [measurement of palmo] he maior por que alem de estender toda a mão, como dixee, tem mays, que uira o dedo polegar de costas atee a primeira junta. Este se chama palmo de Goa [...]*<sup>418</sup>

Manuel Fernandez in his *Livro das Traças de Carpintaria* in 1616 again reiterated this principle for measurement of a *palmo de Goa*:

*Cada palmo de Goa he hum de vara e hua polegada desde a ponta da unha atee a primeira junta*<sup>419</sup>

This, according to Leitão and Lopes, would have made the *palmo de Goa* 25 cm and the *rumo* 150 cm, an opinion to which Albuquerque and Domingues subscribed.<sup>420</sup>

However, Castro gave the *palmo de Goa* as 25.67 cm in his dissertation.<sup>421</sup> He based this on the *vara*, a seventeenth century measurement for which the metric equivalent is known; from there he extrapolated the *palmo de Goa*.<sup>422</sup> This put the *rumo* at 154 cm and as the Regimentos clearly stated that the *palmo de Goa* was divided into ten

---

<sup>418</sup> The third [measurement of a *palmo*] is bigger because besides extending to all width of the hand, as I explained before, has more because, it turns the thumb finger in is back until the first joint. This is called palm of goa. (Oliveira 1991, 88)

<sup>419</sup> Each *goa* palm is equal to one of *vara* plus one inch counting from the tip of the nail to the first joint (Fernandez 1989, 18v)

<sup>420</sup> Leitão and Lopes 1990 468, see also Albuquerque and Domingues 1994, 950.

<sup>421</sup> Castro 2001, 290.

<sup>422</sup> Castro 2001, 289.

*polegadas*, each *polegada* would have been 2.567cm, a little longer than an English inch. As such, the reconstruction work for the *Santo Antonio de Tanná* assumed measurements of 154 cm for the *rumo*, 25.6 cm for the *palmo de Goa*, and 2.56 cm for the *polegada*.

### Scantlings

As stated before, the excavation team was not able to disassemble the hull and no consistent measurements of the available timbers exists. Most of the following scantling list was based on the site map and photomosaic together.

### Keel

The keel with an estimated length in between 30 m to 32.25 m was not accessible to the excavators and no field record exists. The estimation of the dimensions of the keel is explained in the next chapter.

### Stem post

The stem post was either missing from the surviving hull remains or it was not identified in the several tons of out-of context timber that had to be removed during the excavation. Has with the keel a discussion on the dimensions of the stem is presented in the next chapter. The bow of the ship did not survive, which confirms Antonio da Cunha de Melo's account of the loss of Fort Jesus, where he states that the ship sank because most



equipment slid to the bow due to the ship's inclination.<sup>423</sup> If the ship sank bow first, it is more than likely that its stem was either destroyed hitting the bottom, or rapidly decayed due to the over weigh stressing the bow timbers.

### Stern post

The complete stern post did not survive and, although the aftermost timber recorded seems to be the lowest portion of the post, its poor state of preservation did not allow the retrieval of its shape and full dimensions. Based on the photomosaic it was possible to estimate it's molded and sided dimensions suggesting a square section with 40.1 cm on a side.

The stern assembly seem to have the stern post (a) plus two other inner posts and one timber. The first inner post (b), forward from the stern post, receives the fashion pieces, the second inner post (c) locks them in place and is notched to receive the wing transom and the transom pieces. The reason for the timber was not self evident, the first clue to its use was the notches on the post seen in the photographs, the second clue was the gap between the last frame sitting on the keel and the stern assembly due to the rake of the stern structure. These led to the conclusion that this timber seems to exist to receive the heels of the necessary Y frames to close that gap (Fig. 53).

---

<sup>423</sup> Melo [w.d.].

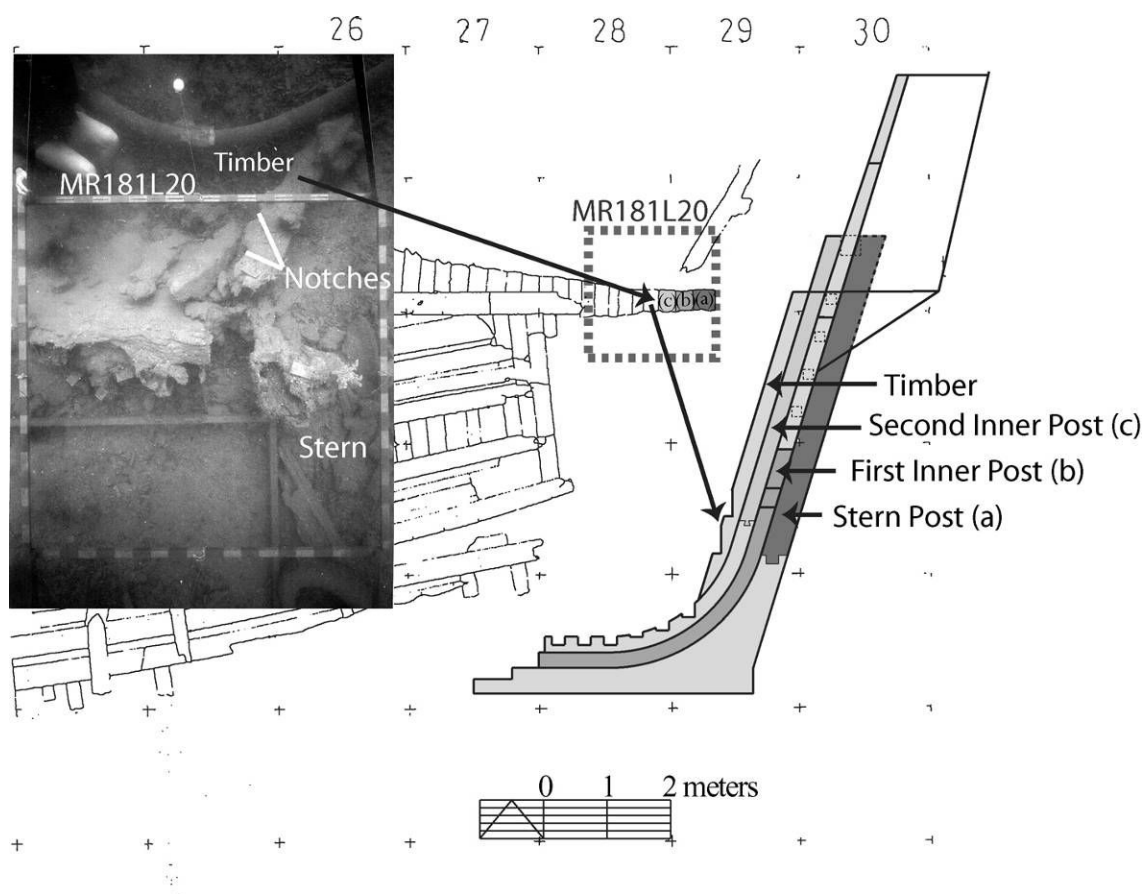

Fig. 53. Photograph MR181L20, detail of site plan and interpretation.

### Frames

According to the site plan, which was corroborated by the photomosaic record, the framing pattern of the ship indicated a room and space of 40.96 cm determined by a space between floors of 20.48 cm, close enough to 8 *polegadas* (20.32 cm), with a gap of 5.12 cm, again close to 2 *polegadas* (5.08 cm), between futtocks.

Fifty-five frames were visible on the site plan, each consisting of a floor, two first futtocks, two second futtocks; third futtocks may have existed, but did not survive (Fig.

52). For the floor dimensions, the study of the photographs where floors were visible gave an average of 20 cm to 21 cm sided.

In photograph MR4R-26 it was possible to see the master frame of the vessel and the measured dimensions were 20 cm sided for the floor timber (Fig. 54).

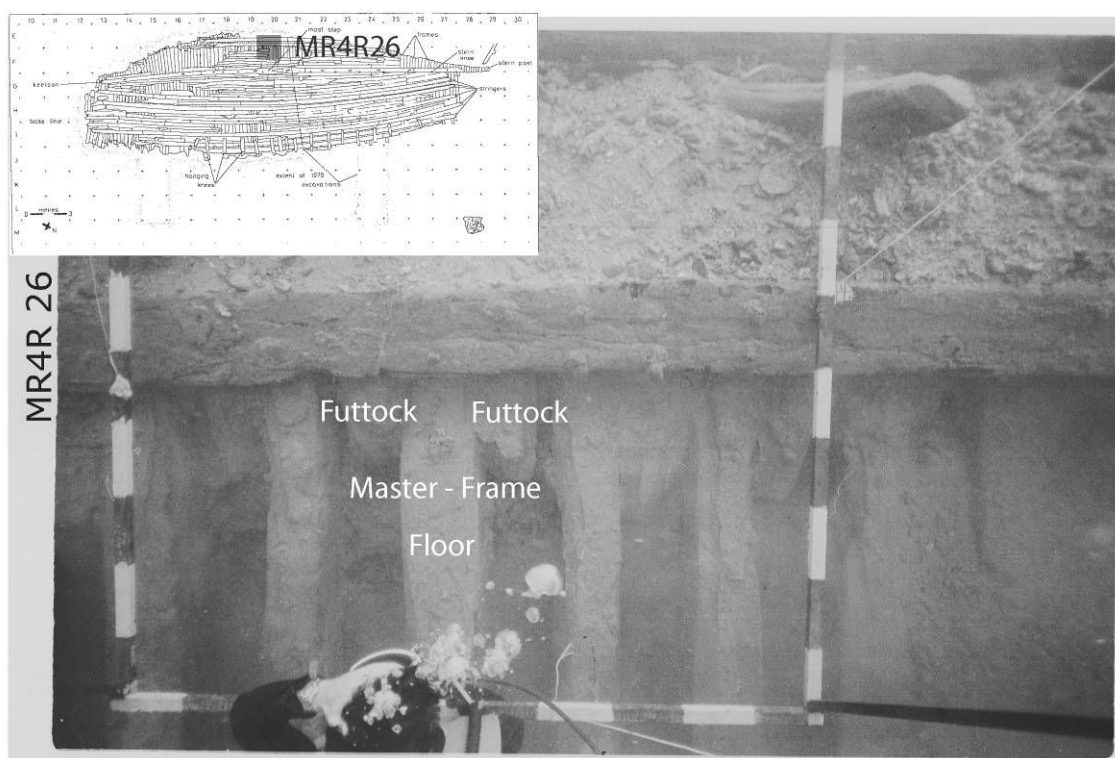

Fig. 54. Photograph MR4R-26 the bow is to the left. (Courtesy Robin Piercy)

Regarding previous studies on the frames, Jordon gave an average sided dimension of 23 cm and an average molded dimension of 26cm while Thompson initially gave an average of 20 cm square.<sup>424</sup> Frames visible on 22 photographs were measured, they average 20 cm, this thesis rounded the sided dimensions to the closest contemporary equivalent of 8 *polegadas* (20.48 cm) and followed Jordon on the molded dimensions while adjusting them to the Portuguese's measures of a *palmo de Goa* (25.6 cm).

Considering that the molded dimensions of both floors and futtocks usually taper slightly, if a floor starts with one *palmo de Goa* (equal to 25.6 cm) the heads should be molded about 8 *polegadas* ( 20.48 cm). With these dimensions and the spacing from frame to frame centerline of 16 *polegadas* (40.96 cm), to fill a ship of 21 *rumos* keel (32.34 m) would be needed about 81 full frames.

Regarding the futtocks, Jordan measured nine and they presented an average square section of 14 cm on a side.<sup>425</sup> In the case of *Santo Antonio de Tanná's* reconstruction, analysis of the photomosaic suggests a section 15 cm sided for both the first futtocks and second futtocks. Considering that 6 *polegadas* was equal to 15.36 cm, the dimensions of the futtocks have a high probability of being 15.36 cm. However, the futtocks had to match the dimensions of the floors which tapered in size as they approached the heads. This gave the first futtocks the molded dimensions of 8 *polegadas* tapering to 6 *polegadas*, or 20.48 cm tapering to 15.36 cm. The molded dimensions of the second

---

<sup>424</sup> Jordon (2001, 305) concludes his average after the measurements of 11 frames; see also Thompson 1988, 26.

<sup>425</sup> Jordan 2001, 306.

futtocks followed the same principle, starting with the same molded dimensions as the end of the first futtock and tapering to 5 *polegadas* (12.8 cm). Due to the castles a third futtock was added in the stern and it followed the same principle and ended with a square section of 4 *polegadas* (10.24 cm).

Shipbuilding treatises and shipwreck remains together indicate that the floors and futtocks of large wooden vessels usually tapered as they extended upward. The rate of tapering for Portuguese ships of the late seventeenth century could not be ascertained from any source. What I have described here a “best guess” based on the excavation experience on other Portuguese or Iberian-built shipwrecks.

The joinery arrangements were also unknown but the frame assembly may have used dovetail joinery with treenails and iron nails characteristic of Iberian ships.<sup>426</sup>

### Keelson

The surviving length of the keelson was 29.68 m long with an average dimension of 34 cm sided and 30.72 cm (12 *polegadas*) molded. The keelson was composed of three pieces. Unusual horizontal rounded butt scarves connected the three pieces with the inner curvature of the butt scarves pointing to the extremities of the ship (Fig. 55). The first piece, which was complete, was 12.88 m in length and extended from the stern area to the second piece, the mast step (described later). The third piece, which was incomplete, was 8.12 m in length, attached to the mast step, and continued towards the

---

<sup>426</sup> Oertling 2001, 235; see also Oertling 2005; see also Rieth 1998.

bow of the ship where it started to taper and ended with a sided dimension of 27.52 cm. The estimated original length of the keelson was 30 m. The keelson appeared to be bolted with two iron bolts on every frame. However, according to the site plan some of the bolts completely missed the frames.

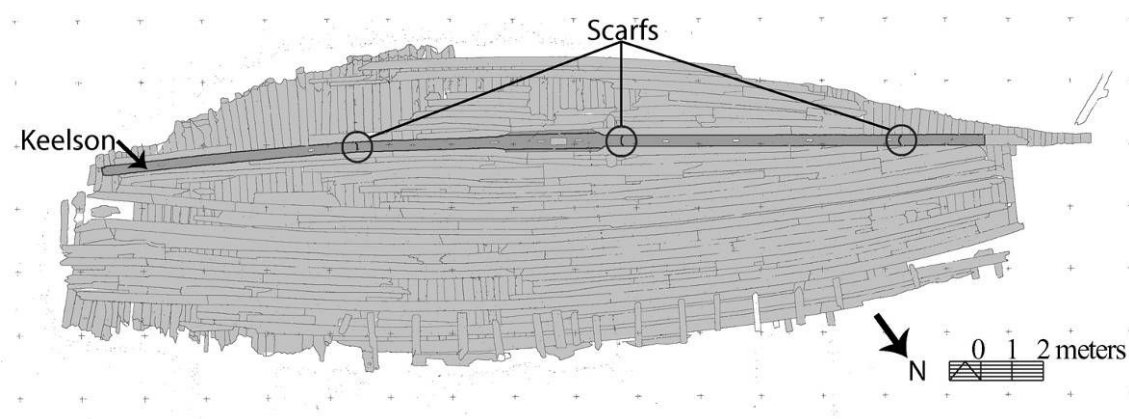

Fig. 55. Surviving length of the keelson, notice the scarves.

### Mast step

*Santo Antonio de Tanná's* mast step was an expanded part of the keelson a feature typical of Iberian ship building practices.<sup>427</sup> Each side of the keelson step was reinforced or 'fished' with a thick plank that was approximately 3 m in length and 10 cm thick (Fig. 56).<sup>428</sup> No bolts or trenails were discernible, and it is unknown how the fish planks were

<sup>427</sup> Oertling 2001, 236; see also Oertling 2005; see also Rieth 1998.

<sup>428</sup> Visible in photograph MRL169L 19.

secured. The mast step had a length of 3.2 m and a width of 50 cm. Together with the encasing pieces, the total width was 70 cm.<sup>429</sup> The maststep mortise was 48 cm in length with a width of 21 cm, but its depth was unknown; in the reconstruction the depth was estimated as six *polegadas* (15.36 cm). Two holes for the pump tubes were represented on the site plan and are visible in photos of the step. The holes were cut through the ceiling planking on either side of the keelson immediately aft of the step. Only the port side have been used as the starboard hole was partially covered by a ceiling plank.<sup>430</sup>

#### Mast partners / stanchions

Two mortises for stanchions existed forward and aft of the mast step. They were 1.3 m apart and had an average size of 25 cm by 5 cm. Due to their proximity to the mast step's mortise it is believed that they supported the reinforced deck beams that also served as mast partners.

---

<sup>429</sup> Jordon 2001, 303.

<sup>430</sup> Visible in photograph MR169L 19.

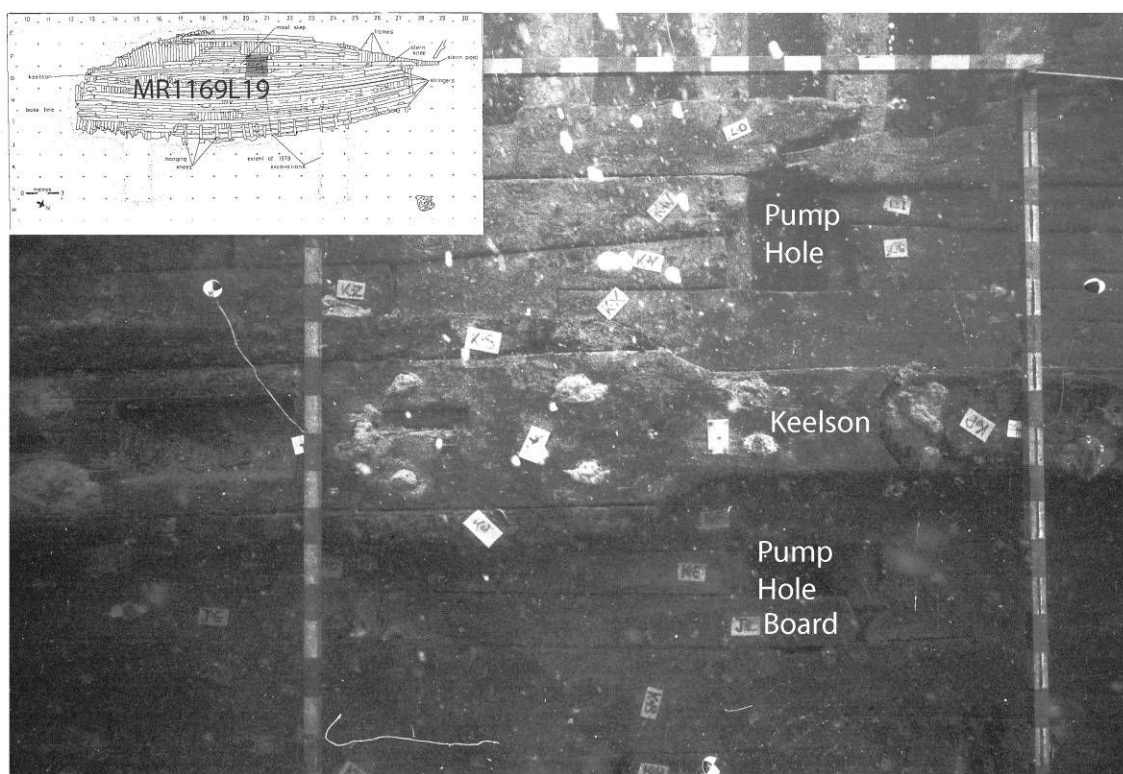

Fig. 56. Photograph MRL169L 19 notice the boards on the port side hole, the bow is to the left. (Courtesy Robin Piercy)

### Stanchions

Six additional mortises for stanchions were cut into the top of the keelson, three forward and three aft of the mast step. Their spacing aft of the mast step was 2.3 m between mortises, while forward they increased in spacing, the first being 2.6 m distant from the mast partner mortise, the second was 3.2 m from the first, and the last surviving third one was 4.9 m forward of the second. All were 20 cm in length and 5 cm in width, but their depth is unknown. The heels of five stanchions survived, each of which averaged



22 cm square (Fig. 57).<sup>431</sup> The most complete of the stanchions was 2.8 m in length.<sup>432</sup>

This length, plus an estimate for the size of the deck beams and planking thickness, provided a basis for latter estimation of the hold's depth.

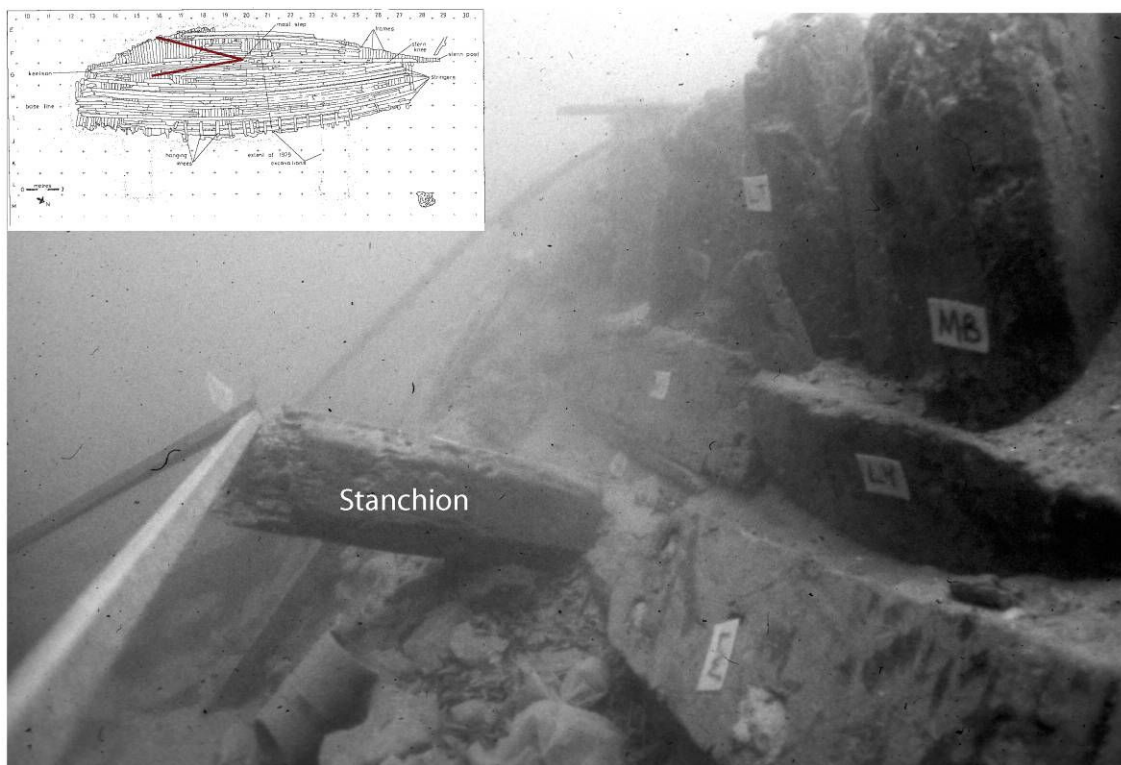

Fig. 57. Photograph of a stanchion *in situ*. (Courtesy Robin Piercy)

---

<sup>431</sup> Jordan 2001, 303.

<sup>432</sup> Thompson 1988, 26.

### Hull planking

The hull planking had a thickness of 10 cm (around 4 *polegadas*). No wood sample were take for dating, nor is there any information regarding the type of fastenings used to secure them to the framing.

### Ceiling

The ceiling of the ship covered the entire inner side of the hull up to the hanging knees of the main deck. The ceiling was a veritable puzzle with every type of scarf, stealers and clamps present. This could be have been caused by several factors: repairs due to wear, enemy action, refitting, a lack of wood or use of scrap wood for cost reduction during the initial construction. Nevertheless, Thompson gave 2 cm thickness for the planking, but Jordan stated 2 cm to 5 cm thickness.<sup>433</sup> Considering the disarray of pieces used to compose the ceiling, a variable thickness seems more probable. The planking is secured in place by nails and treenails without any apparent pattern.

### Stringers

Nine stringers were recorded, seven stringers on the port side and two stringers on the starboard side. Their dimensions were 12.5 cm molded and 20 cm sided.<sup>434</sup> The more complete port side showed that the first three stringers were placed closely together at the floor head line and the turn of the bilge, a potential weak spot on any wooden ship.

---

<sup>433</sup> Thompson 1988, 26; see also Jordan 2001, 305.

<sup>434</sup> Jordan 2001, 306.

At the hold's mid-height stringers four and five were added, spaced in the following manner, stringer number four is exactly at mid-distance between the third stringer (at the turn of the bilge) and the fifth stringer which rests at 2.16 m height (counting from the top of the keel to the upper left corner of the stringer). Finally, two more stringers, numbers six and seven, serve as a basis for the hanging knees almost at the top height of the hold. The best preserved stringer (length of 29.2 m) was on the port side and the least preserved was on the starboard side (length of 12.5 m). The best preserved stringer averaged sided dimensions of 25 cm and was composed of four pieces: a very long piece, starting at the stern with a length of 19.10 m, a second piece about 5.35 m, a third which length was 2.65m, and an incomplete fourth with a length of 2.10 (totalizing 29.2m) and whose angle of approach to the keelson indicated that it probably would have extend between 1 m to 1.5 m giving the original length of the stringer about 30 to 31 m.

The majority of the stringer scarves were diagonal. However, the second stringer on the port side had a butt scarf, a stealer, and ended forward in a flat scarf. The sixth stringer also presented a flat scarf at its forward end. The last stringer could also have ended forward with a flat scarf, but degradation of the wood made its analysis inconclusive. All of the stringers are nailed in place through an extensive nailing of two nails per frame, and two nails per frame and per adjoining futtock where possible.

#### Deck clamp

The deck clamp was difficult to analyse. Two pieces survived on the port side that could have been part of the lower deck clamp (A and B on Fig. 58), although A does show a

groove that might have received the beam. Both pieces, A and B, are too deteriorated to say for certain if they are part of the deck clamp. Observation of the few photographs where piece A appears (MR4R06, MR3R05, MR3R06 and MR3L06) are not clear enough to show if the groove is man made, and do not allow one to state if it could be part of the deck clamp (Fig. 59).

In Hubault's edition of *Construction* (1691) and Lafon's edition of *Construction* (1695), there exist two pieces, the *serre-bauquieres* (numbered 53 in the figure of timbers) translating to 'stringer - beams' that could mean 'deck clamp' and the *serre-goutieres* (numbered 91 in the figure of timbers) that translates to 'shelf-timber' or 'deck clamp'.<sup>435</sup> The problem is that *serre-bauquieres* are grooved and the *serre-goutieres* are not, on *Album de Colbert* (1670), *serregoutiere* shows as a grooved piece and is also translated shelf-timbers, if both could have been shelf-clamps would mean that sometimes a grooved piece was used, but not all the time (Fig. 60).<sup>436</sup>

---

<sup>435</sup> Hubault 1691, 3 and 5; see also figure 24 on chapter VI, 71.

<sup>436</sup> Anonymous 1988, 6 and plate 13.

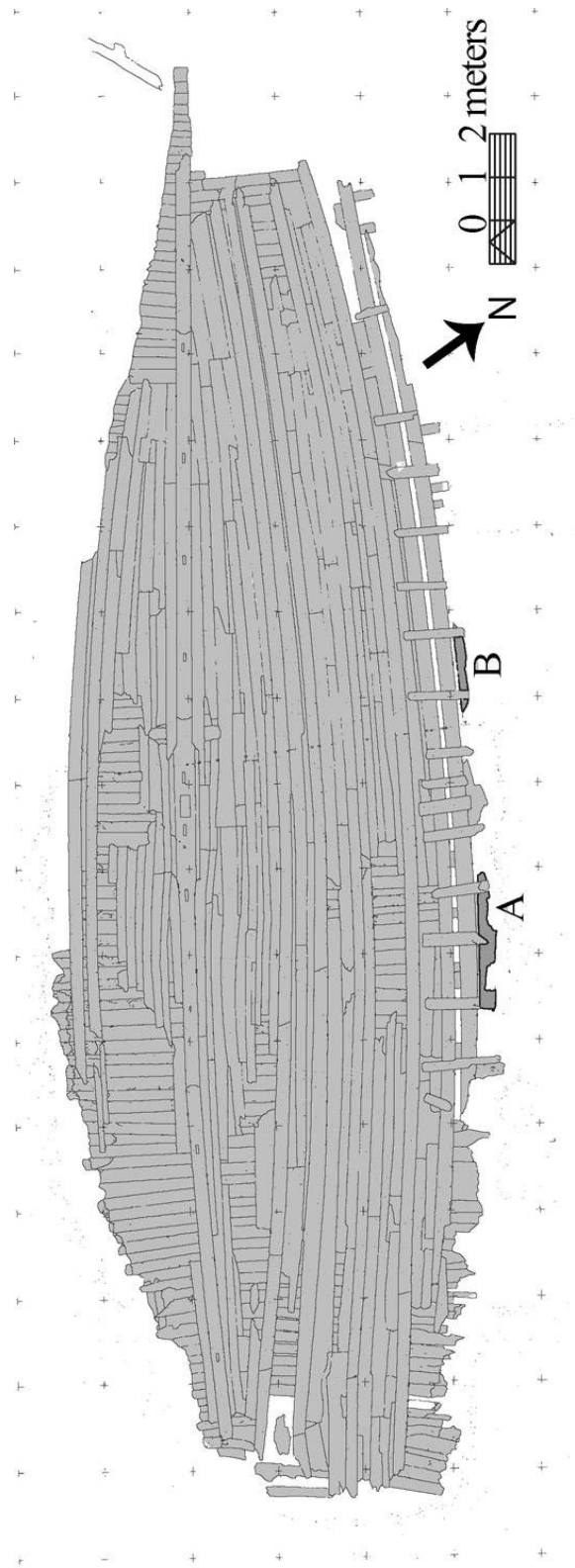

Fig. 58. Surviving port pieces.

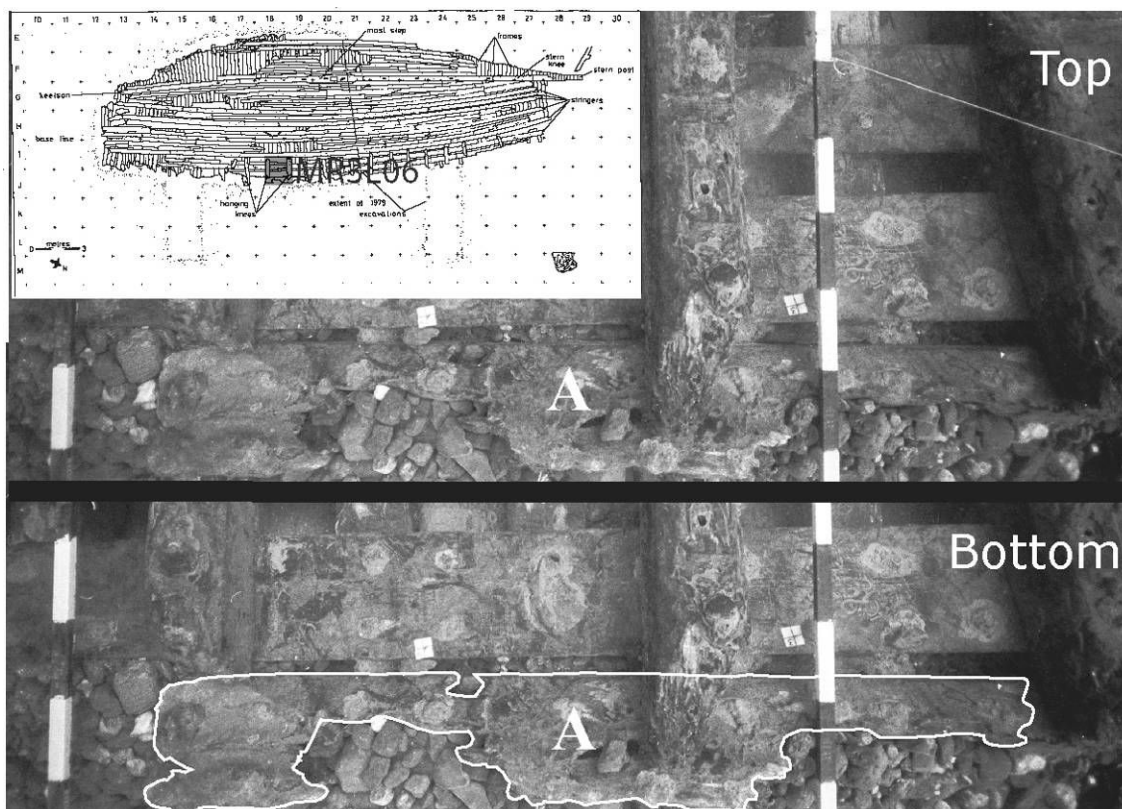

Fig. 59. The picture MR3L06 which is the one that shows more clearly piece A. Top shows a cut-out of the original picture, Bottom shows the piece with accentuated outlines.

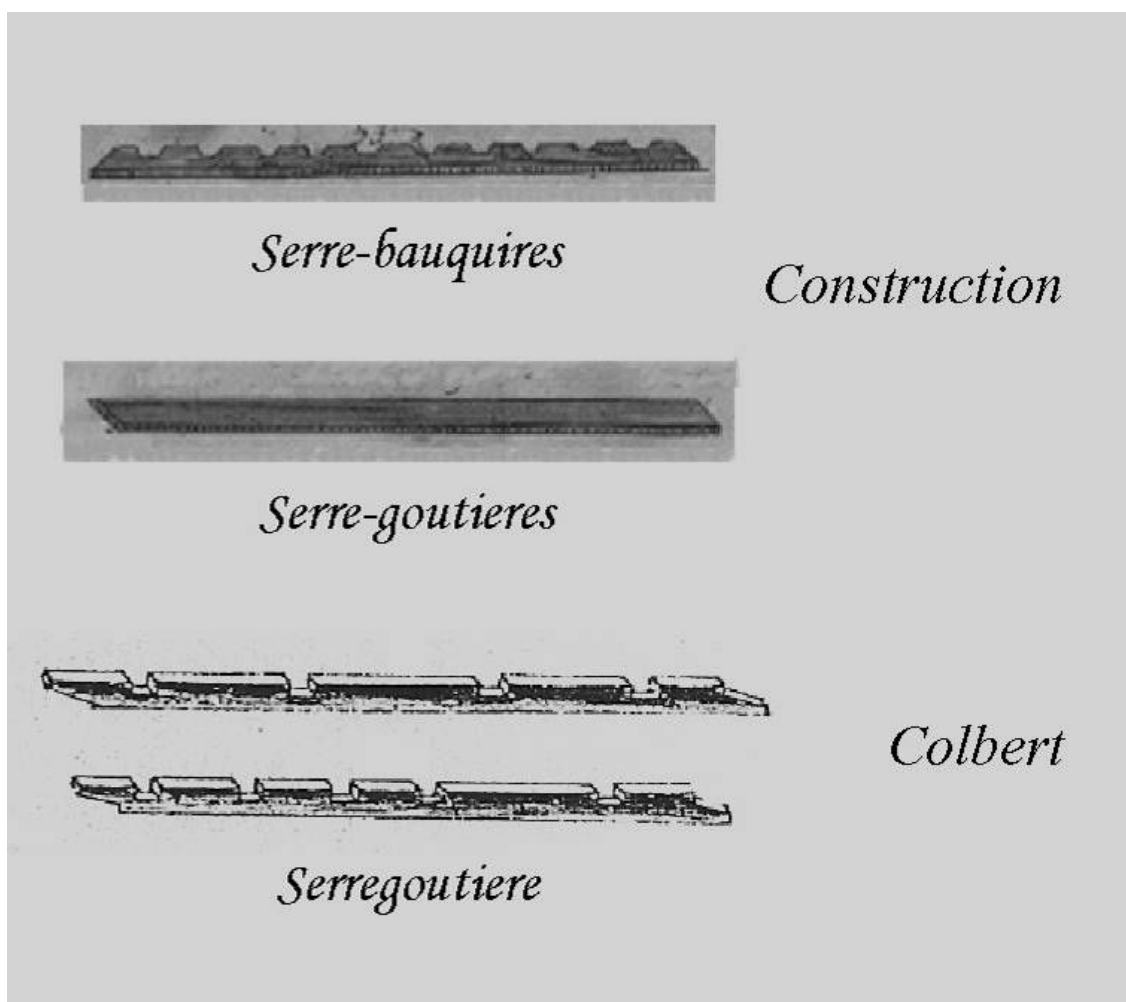

Fig. 60. *Serre-bauquies*, *serre-goutieres* and *serregoutiere*. (After Hubalt 1691 and Anonymous 1988).

In the case of Portuguese construction, there was the habit of using a combination of horizontal (*curvas da abertona*) and vertical (*curvas de alto*) knees to set and support the beams. This combination of knees would not require grooving the shelf clamp to lock the beams in place. Both pieces are shown in the *Relação* (c. 1690s) and it is almost

certain that they existence in the *Santo Antonio de Tanná*.<sup>437</sup> Has we can not prove the existence of a grooved shelf clamp on the hull remains of the *Santo Antonio de Tanná*, it is likely that the seventh stringer served in the capacity of a shelf-clamp.

### Hanging knees

Fifteen hanging knees survived.<sup>438</sup> They ranged between 15 cm to 30 cm sided. Every knee was bolted to two stringers using two nails per stringer.<sup>439</sup>

This was the information available and it clearly provided enough material to start a plausible reconstruction of *Santo Antonio de Tanná*.

---

<sup>437</sup> Anonymous c1690s.

<sup>438</sup> Thompson 1988, 26.

<sup>439</sup> Jordan 2001, 306.



## CHAPTER IX

RECONSTRUCTION OF *SANTO ANTONIO DE TANNÁ*

The main research goal of this thesis is to determine if it is possible to use the available information to effectively reconstruct *Santo Antonio de Tanná* and to present a model for further studies. The first phase of reconstruction was the gathering of the archaeological, historical, and iconographic data available for the reconstruction. The previous chapters presented the evolution and importance of the frigate in addition to the history of *Santo Antonio de Tanná* and of the fort associated with the Portuguese frigate's loss in 1697. We have also examined the archaeological excavation of the wreck and features of its construction.

The basis for reconstruction was derived from the archaeological record, however, several gaps existed: the overall dimensions of the vessel, the hull shape, and elements of the scantlings list. This chapter is intended to fill those gaps, using a combination of the written and iconographic sources, inferences from the archaeological record, and some educated guesses.

#### Overall dimensions

The bow of the *Santo Antonio de Tanná* did not survive and certain dimensions could therefore not be ascertained from the archaeological record. The full length of the ship, the length of the keel, and the breadth of the ship had to be inferred from surviving portions of the hull end frames and historical sources.

Jordan estimated a beam-to-length ratio of 1:3.1 but this has been revised for the present reconstruction due to a re-estimate of the keel length as 32.5 m. The ship is presently believed to have been 37.50 m in length with a breadth of 11.30 m, giving it a ratio of 1:3.3.<sup>440</sup>

These conclusions came from the analysis of the seventeenth century ship models presented in Culver and further study of the hull remains.<sup>441</sup> *Santo Antonio de Tanná*, considered a fourth rate, was designed to carry 42 guns and later remodelled for 50 guns; Culver's models for ships rated as 50-gun frigates or fourth rate ships of the line are represented in the following table (Table 4). It shows that for fourth rates, the guns were divided into two major batteries either with the same number of guns per deck or by the general rule that the main deck should have one more gun than the weather deck. Strengthening this conclusion was a Portuguese historical source, which stated that a *fragata* was a ship of two batteries.<sup>442</sup> Assuming that the *fragata Santo Antonio de Tanná* followed the same principles seen in Culver's models for its two batteries, it would initially have had an 11-gun battery in the main deck and a 10-gun battery in the weather deck.

---

<sup>440</sup> Jordan 2001, 307.

<sup>441</sup> Culver 1954.

<sup>442</sup> Leitão and Lopes 1990, 273.

**Table 4. Seventeenth-century 50-gun frigates and fourth-rate models**

Rate	Gun Battery			Total * 2 batteries	Model Year	Name	Nationality	Pg.
	Main Deck	Weather Dec	Castles*					
44	10	10	2	20*2=40	1666	Bristol	English	9
50	12	13	2	25*2=50	Mid 17 <sup>th</sup>	?	English	10
48	11	12	5	23*2=46	1681	?	English	21
50	11	11	3	22*2=44	1682	?	English	23
50	11	11	5	22*2=44	1685	?	English	24
56	12	11	5	23*2=46	End 17 <sup>th</sup>	?	English	28
50	11	11	3	22*2=44	1690's	?	English	33
44	11	10	0	21*2=42	End 17 <sup>th</sup>	?	English	35
48	10	?	3		1690	?	English	36
80?	12	11	5	23*2=46	1692	Boyne	English	39
50	11	11	4	22*2=44	1695	?	English	41
50	10	10	2	20*2=40	1696	Prins Carl	Danish	42
50	10	8	0	18*2=30	1670-96	?	Danish	46

Keeping in mind the conclusion of the paragraph above, it is time to address the ship remains. The surviving pieces of the keelson measured 26.5 m in length and the beam of the *plão* (distance between starboard and port turn of the bilge) is 4.7 m to 5 m, or 18.5 to 19.5 *palmos*. The unit of measurement used in the seventeenth century by the Portuguese was the *rumo*. According to the last phrases of *Regimentos*, each *rumo* was divided into two *covados* and each *covado* has three *palmos de Goa*. Each *palmos de goa* has ten *polegadas*.<sup>443</sup> It is presently believed that the *polegadas* are equivalent to English inches. This makes the *palmos de goa* 0.256 m, the *covado* 0.768 m and the *rumo* 1.536 m.<sup>444</sup> Using the keelson length as a minimum size for the keel produced a 16 *rumos* (24.64 m) frigate. However following the natural curve created by interceding the straight line of the keelson with the arc of the surviving stringers pointed to a minimum original keelson length of 35.75 m or 23 *rumos* or 138 *palmos de Goa* (Fig. 61). A ship of 138 *palmos* total length must have been an 18 to 19 *rumos* frigate (27.72 m to 29.26 m).

---

<sup>443</sup> Pona 1890, 219,22.

<sup>444</sup> Castro 2001, 287-9.

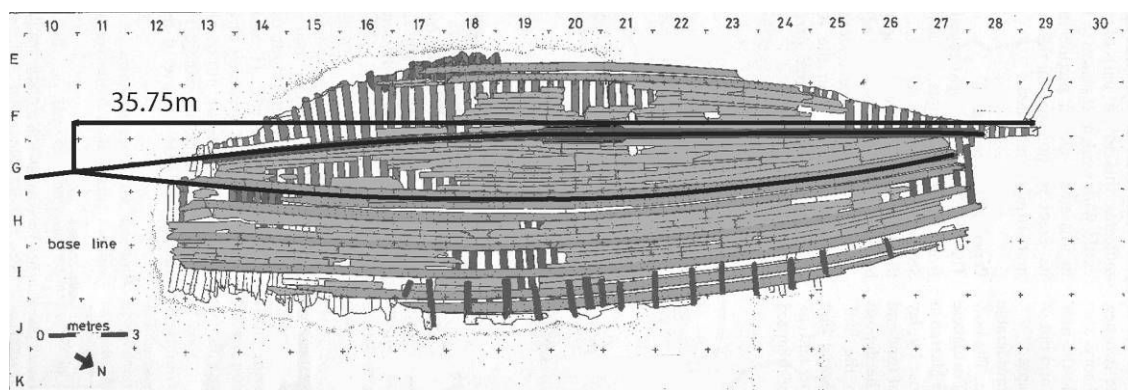

Fig. 61. The interceding curves.

According to the 1692 *Regimentos*, ships above 16 *rumos* had the mast step placed exactly three *palmos de Goa* (76.8 cm) abaft the centre of the ship.<sup>445</sup> On the wreck the maststep was 17 m from the sternpost, and adding 3 *palmos* (76.8 cm) makes 11.5 *rumos* (17.71 m); if the centre of the ship was 11.5 *rumos* (17.71 m) then the ship had to be 23 *rumos* or 138 *palmos* (35.42 m) total length. A total ship length of 138 *palmos* (35.42 m) meant a keel of 19 *rumos* (29.26 m). However, as the position of the sternpost was not the end of the ship, the rake of the sternpost was taken in account. A 19 *rumo* length ship had a rake of 7.5 *palmos* (1.92 m) and this meant that it was necessary to add this to the 11.5 *rumos* or 69 *palmos* (17.71 m). This indicated that the centre of the ship was at 76.5 *palmos* (19.58 m). Multiply by two and the total length of the ship was 153 *palmos* (39.16 m). According to the *Regimentos*, a 153 *palmos* (39.16 m) total length was one *palmo* less than a ship with a keel length of 21 *rumos* (32.34 m), and did not correlate to

---

<sup>445</sup> Esparteiro 1987, 52-4.

a frigate with an 18 *rumos* (27.72 m) keel. The total length given in the regiments for a frigate's keel of 21 *rumos* (32.34 m) frigate was actually 154 *palmas* (39.42 m).

A frigate with a keel of 21 *rumos* (32.34 m) has a spacing from gun to gun of 11.5 *palmas* (2.94 m), and remembering Table 4, multiply this spacing by 11 guns on each deck suggests that the decks must have had a length of at least 126.4 *palmas* (32.38 m). Moreover, the ship was later refitted to carry 50 guns and this meant that the weather deck battery would have carried 13 guns; using the same interval as the previous ones increasing the length required for the guns to 38.27 m. Both the *Regimentos* and the historical number of guns aboard the ship required *Santo Antonio de Tanná's* length on deck to have been between 37 to 39 m.

The initial height of the vessel was taken directly from the *Regimentos* as it was not available from any other sources. The *Regimentos* specified that frigates with a keel of 21 *rumos* (32.34 m) had a depth in hold of 3.32 m, a main deck of 1.92 m, and a sheer of 1.28 m, totalling 6.52 m of height.

The maximum breadth of the ship was ascertained using a combination of the *Regimentos* measures and the archaeological remains. The *Regimentos* gave 21 *rumos* (32.34 m) frigates a breadth of 10.24 m at the midship (widest) frame. The instructions of the *Regimentos* produced the section marked (a) in Figure 62. Every surviving piece of the ship was placed in that arch. As the totality of known pieces could not have fit in the section, it was expanded until the surviving knee would fit under the deck, resulting in the section marked (b) in Figure 62. The required height in the *Regimentos* plus the

totality of the assembly pattern derived from the archaeological study allowed the creation of the section marked (c) in Figure 62. This allowed a tentative estimation of the ship's height (from the upper face of the keel to the upper face of the weather deck beam) of 25.6 *palmos de Goa* (6.56 m) at amidships and meant that *Santo Antonio de Tanná's* breadth would have been around 11.30 m.

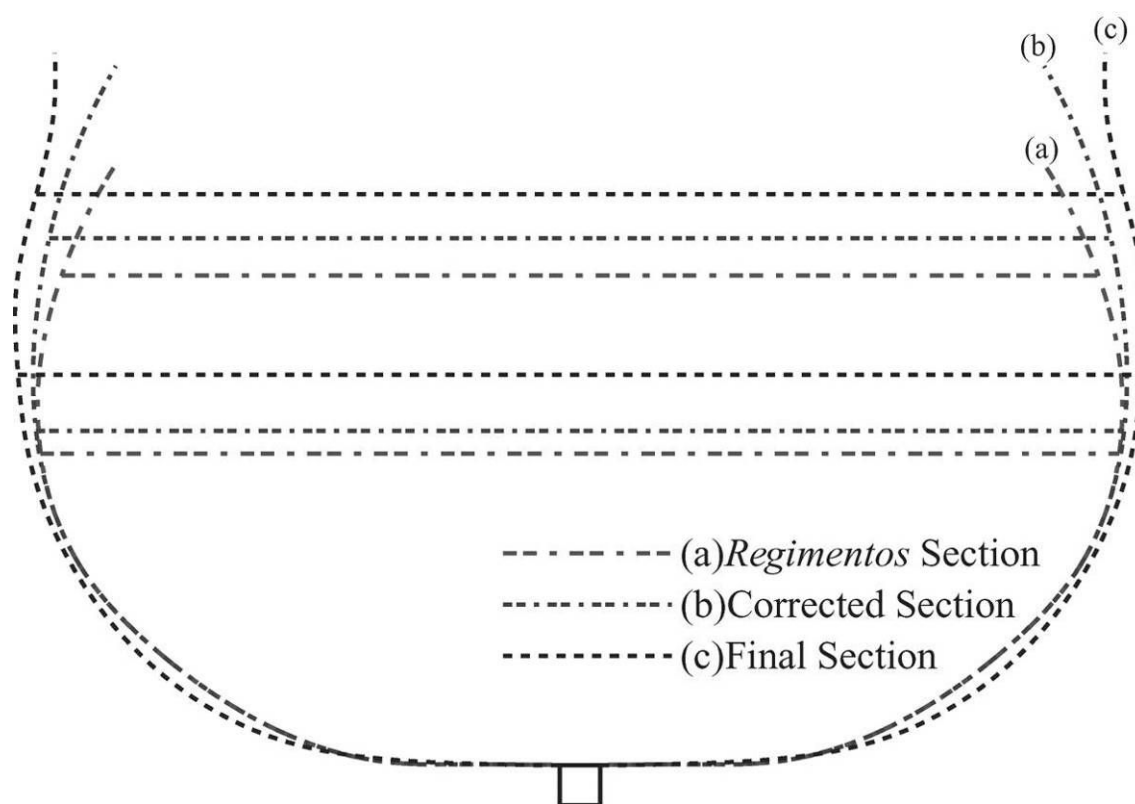

Fig. 62. Amidships initial and final section.

In summary, the estimated dimensions for *Santo Antonio de Tanná* were a length between 37 to 39 m between perpendiculars, extreme breadth around 11.30 m, and

amidships height keel to sheer of 7 m with an estimated tonnage of around 770 tons (Fig. 63).

#### The hull shape

With the basic dimensions of the ship determined it was necessary to fine-tune the design. As Anderson has indicated, from the end of the seventeenth century each nation designed their ships in a different way.<sup>446</sup> A frigate built in England was not the same as one built in Portugal because there were differences in the hull shape. Moreover, key parts of the vessels such as the amidships section, the bow, and the stern had signatures of construction such that an experienced eye could identify the country that built it.

The next steps in the reconstruction process included defining the overall shape of the vessel after defining the key elements of the master-frame, bow, and stern.

A starting point in the search for the overall shape of the vessel were the section-lines derived from the surviving hull which gave a notion – albeit imprecise - of the hull shape (Fig. 64).

---

<sup>446</sup> Anderson 1928, 38.



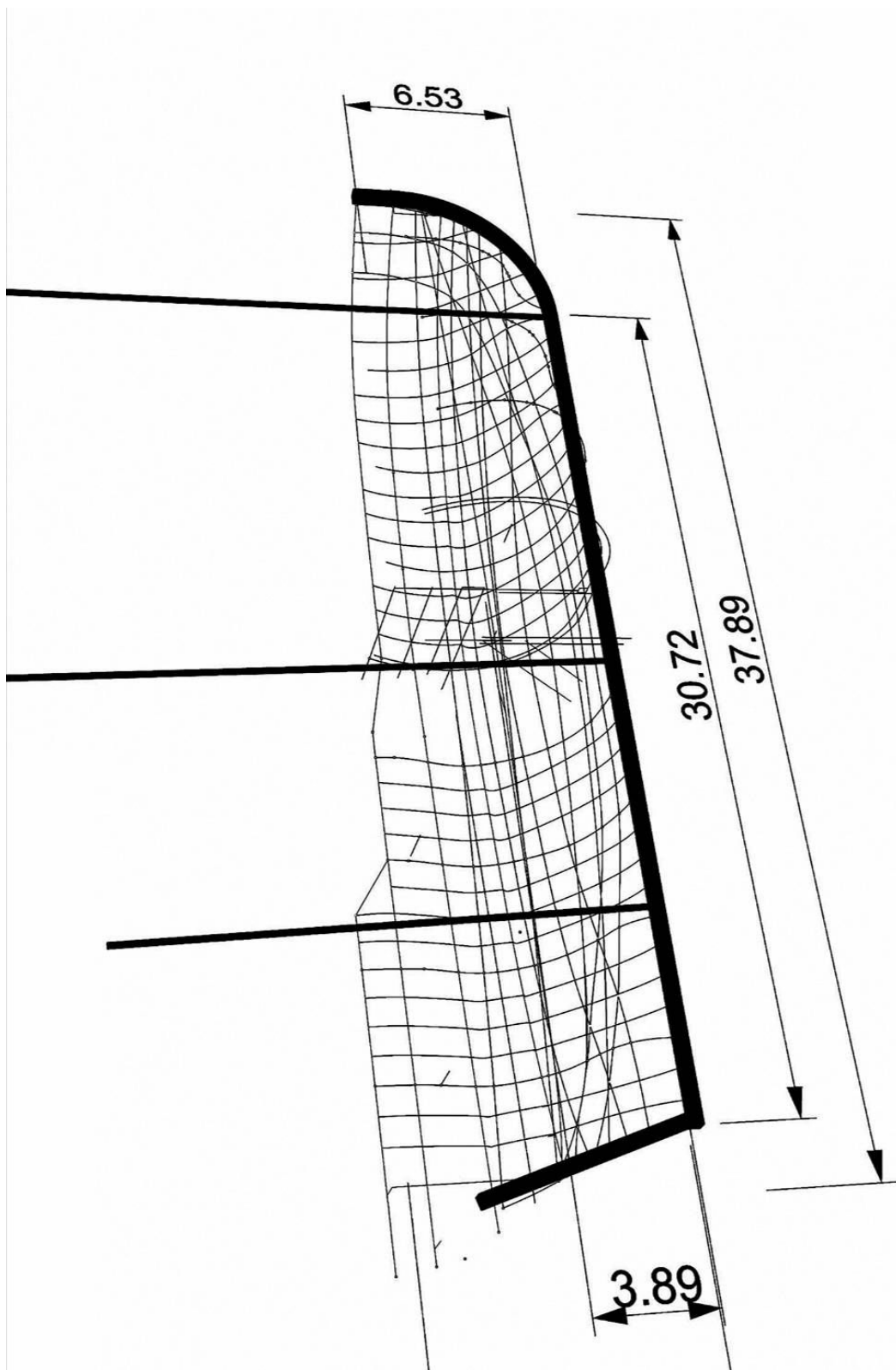

Fig. 63. Initial ship lines with overall dimensions.

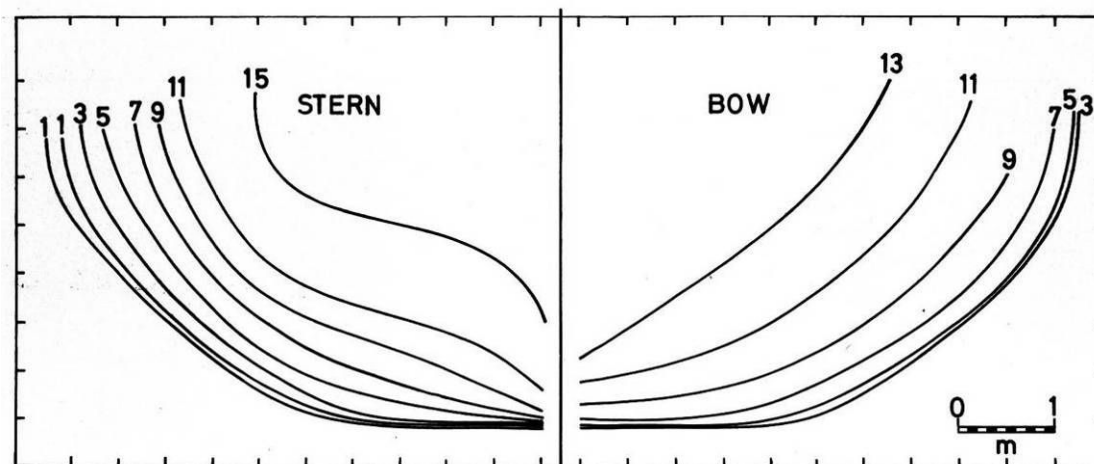

Fig. 64. Original section lines from the Mombasa excavation taken from the interior of the ceiling.  
(Courtesy Robin Piercy)

Two problems arose from the section-lines presented in figure 63. First, the longitudinal hull measurements were incomplete and without them it was not easy to determine the length between sections. It was therefore necessary to move the section forward and aft until an acceptable bottom form surfaced.<sup>453</sup> The second problem with the sections is that they were incomplete – only the lower hull survived – and their shape is unknown above the main deck. Completing the sections from the keel to the weather deck required information from historical sources. The *Regimentos* gave the gross dimensions of the hull and the archaeology recording revealed the shape of the bottom, but to complete the

---

<sup>453</sup> The lines drawings associated with the hull were located in the end stages of this thesis, thanks to the efforts of Robin Piercy.

study it was necessary to ascertain which contemporary seventeenth century lines drawings were most compatible with the information at hand.

Another approach to the problem was developed based on the work of Texas A&M university graduate student, Taras Pevny. Pevny theorized the existence of diagonal lines capable of determining the more important points of the vessel' transversal sections: the turn of the bilge and the maximum breadth. Pevny tested his theory on the *La Belle*, a French light frigate wrecked on the coast of Texas in 1686. If the diagonal information for *Santo Antonio de Tanná* was also visible in the archaeological information, as it was believed to be in *La Belle*, it might have been included in the *Regimentos*.

By testing the hypothesis on the section lines taken from the wreck, it was quickly discovered that the diagonal line for the turn of the bilge, more or less, followed the line of the bilge stringers. It was then necessary to calculate a maximum breadth diagonal. The *Regimentos* specify the maximum breadth amidships and the breadth at the transom, as well as the height of the stem.<sup>454</sup> Those three points marked the run of the maximum-breadth diagonal (the wales that extended around each side of the hull). If the bilge stringer followed the turn of the bilge diagonal, and if the three points given for the maximum-breadth diagonal indicate the run of the wale, then the three points given in the *Regimentos* should also have been the diagonal information sent to the shipyards. On this basis, it was possible to compare hull shapes with contemporary vessels from other

---

<sup>454</sup> Pona 1890, 221-2.

European nations. Two line drawings were selected as being the closest in date to *Santo Antonio de Tanná*: the Keltridge drawing of a English fourth-rate ship, and the Chaillé drawing representing a French 40-gun frigate. Their diagonals were ascertained and compared to the hypothetical diagonal information of *Santo Antonio de Tanná* (Fig. 65).<sup>455</sup>

The results were unexpected. *Santo Antonio de Tanná*'s diagonal in the stern was closest to the English style and the bow was closest to the French. This suggests that the Portuguese had a different style of determining positioning diagonals; this style could have resulted from the importation of both construction styles or it could have evolved from original Portuguese thinking. It was not possible at this time to ascertain which hypothesis was more probable, or if both were valid.<sup>456</sup> The importance of this exercise was the comparison of the resulting diagonals which enabled the presentation of a basic hull shape (Fig. 66).

---

<sup>455</sup> See figure 32 in chapter VII, 105; Keltridge's drawing is at the National Maritime Museum U.K. indexed as KLT0004.

<sup>456</sup> Also because it could be that the Keltridge and Chaillé diagonal placements represent the preferences of those individuals, rather than nationally or regional rules a bigger sampling would be necessary to validate such a hypothesis.

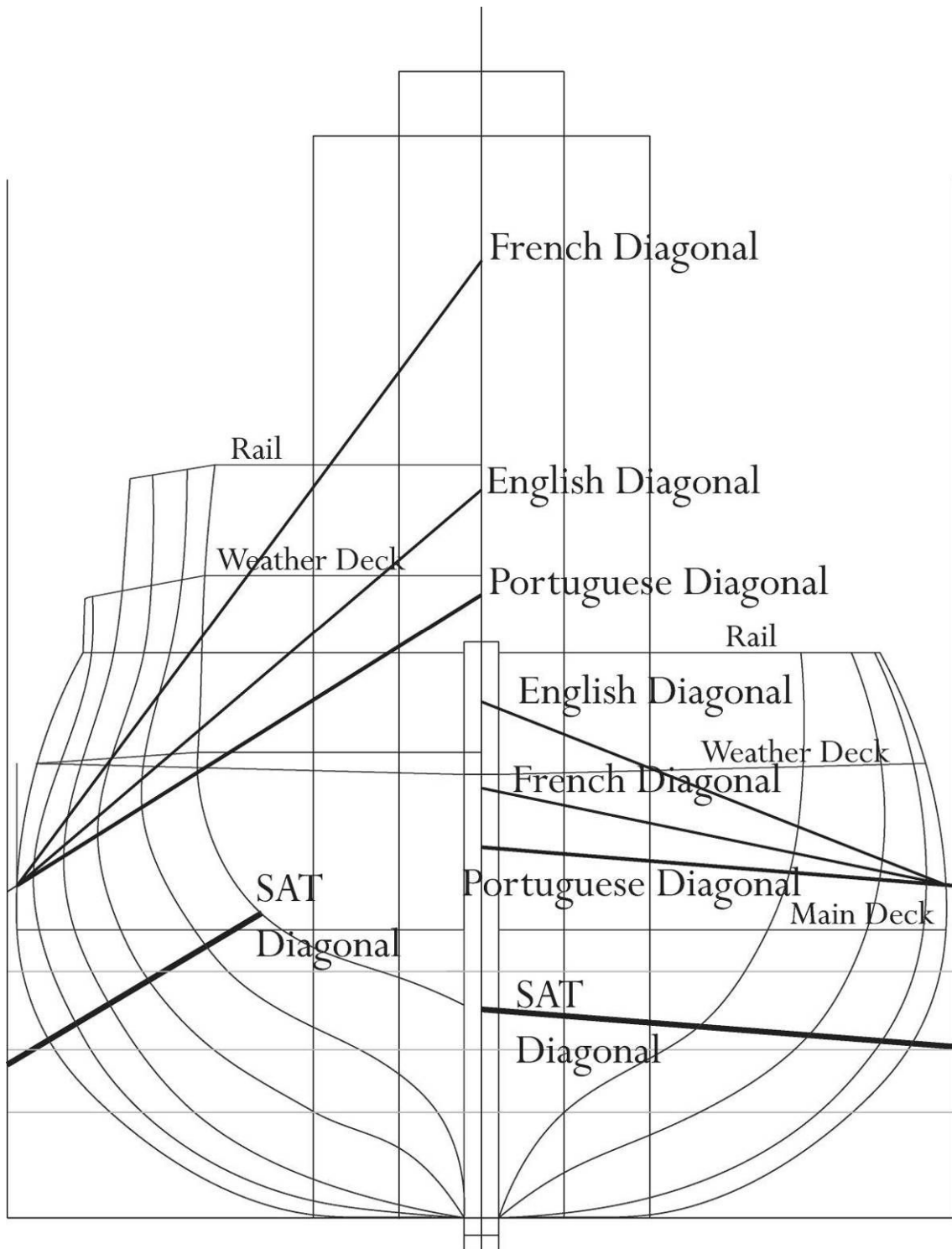

Fig. 65. Diagonals, the Portuguese diagonal is the *Santo Antonio de Tanná* but transferred upwards to originate from the maximum breadth.

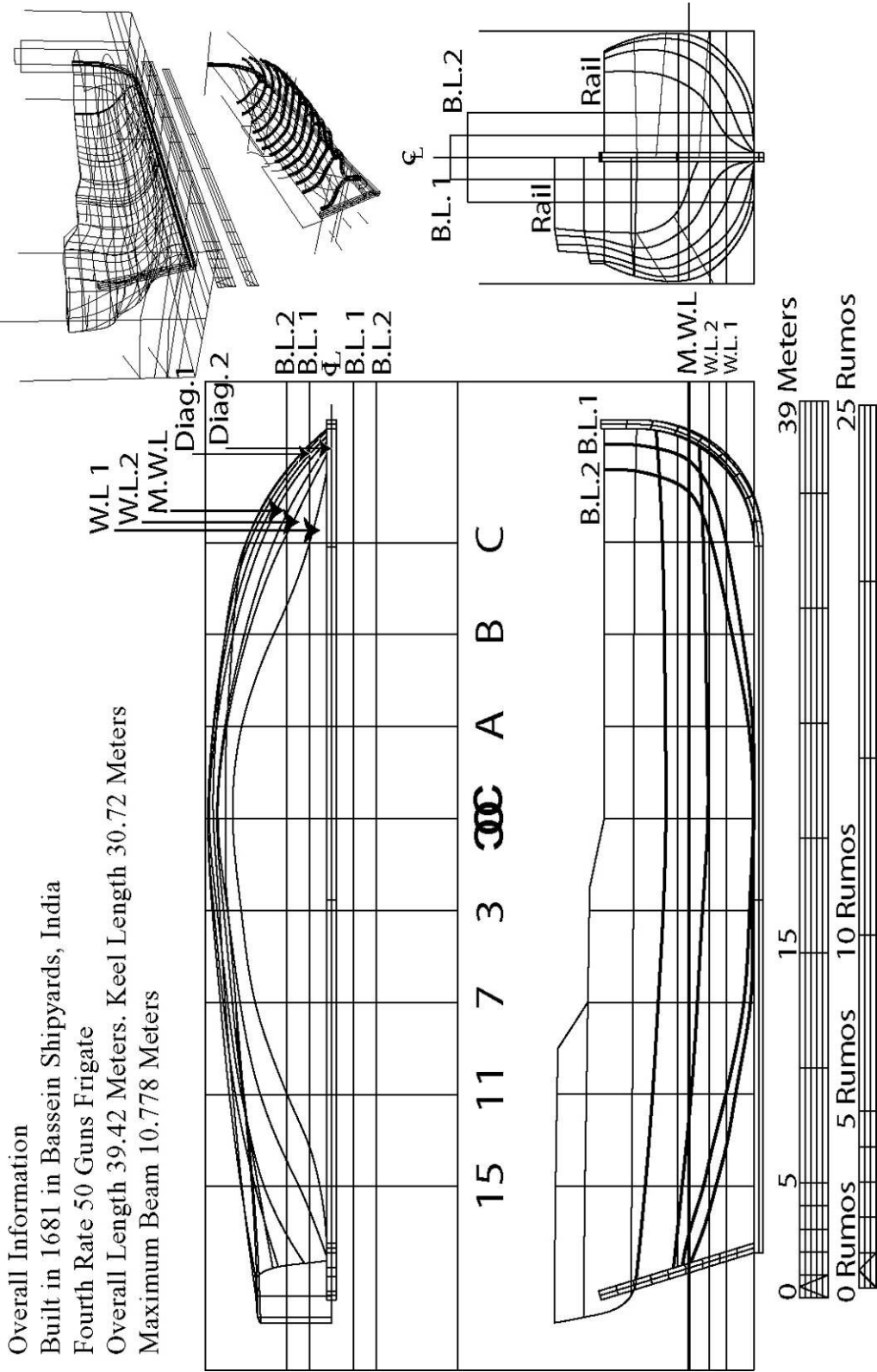

Fig. 66. *Santo Antonio de Tanna* initial hull shape.

Defining the amidships section was the next step in the reconstruction process. The amidships section marked the lowest and widest point of the ship and all other frames forward and aft of its location narrowed in breadth and increased in deadrise towards the end posts. This was a starting point in the framing of a new vessel in a shipyard. After defining the positions of the turn of the bilge, the maximum breadth, and the tumblehome in the master-frame located at the amidships section, shipwrights had only to incrementally narrow the breadth of the following frames and incrementally raise them in proportion to the narrowing. The *Regimentos* defined this precisely for every ship mentioned: the extreme breadth of the master-frame, called the *boca*; the distance between both starboard and port turn of the bilge at the master-frame, called the *plão*; and the tumblehome, called the *recolhimento*.<sup>457</sup> For a 21 *rumos* (32.34 m) frigate, the *plão*,<sup>458</sup> is 20 *palmas* (51.2 cm); the *boca* is at a height of 13 *palmas* (33.28 cm) and is 40 *palmas* (1024 cm) wide; and the *recolhimento* at the main deck is to be 3 *palmas* (76.8 cm). However, as mentioned above, when the section prescribed by the *Regimentos* was confronted with the archaeological record, the maximum breadth line had to be increased by one *palmo* (25.6 cm). This raising allowed all ceiling strakes to fit into the arc. The amidships section presented in the following figure was the combined result of the historical and archaeological sources (Fig. 67).

---

<sup>457</sup> Pona 1890, 221-2.

<sup>458</sup> The archaeological record shows in the case of this ship to be completely flat.

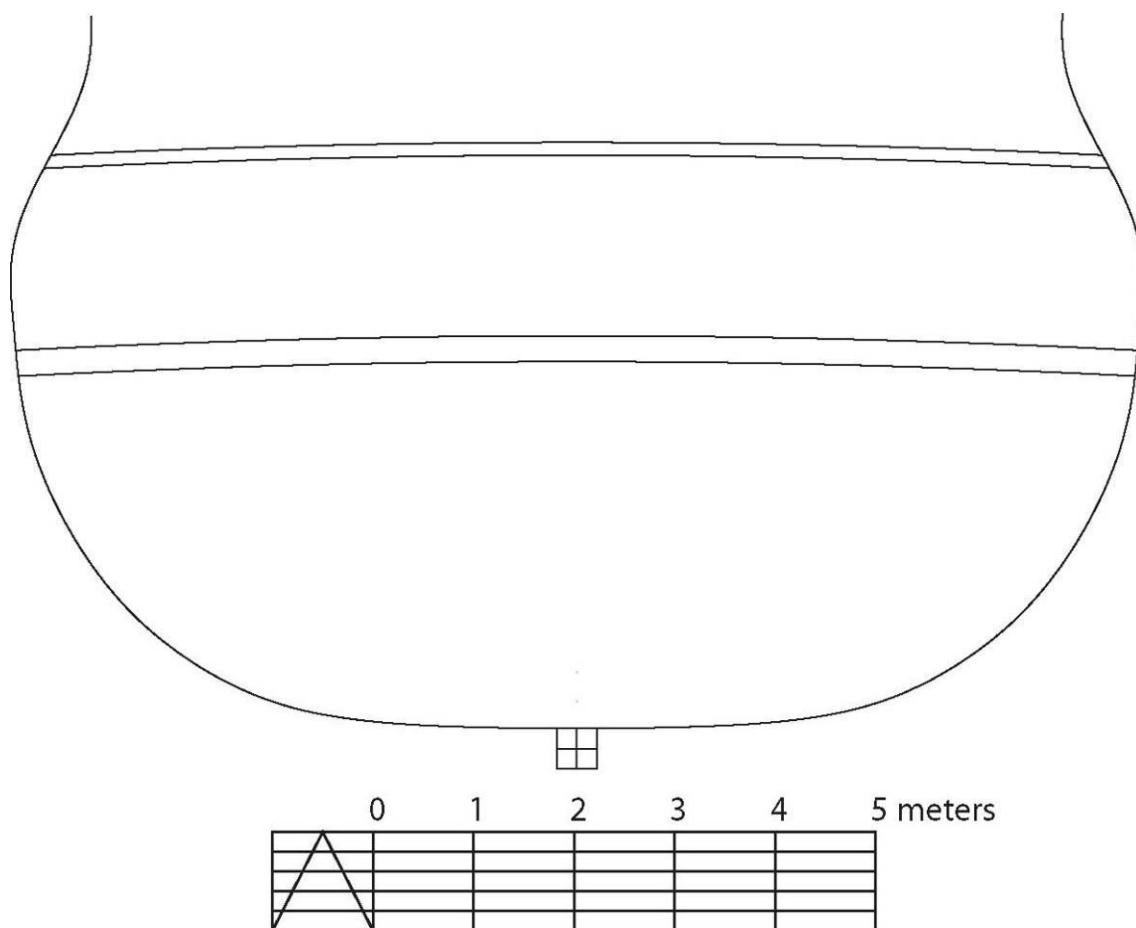

Fig. 67. Master frame section.

After the definition of an amidships frame, the next step was to recreate the ends of the vessel, how the stern and bow of the vessel would have looked, what the level of the narrowing and rising of the frames would be, and the appearance of the stern panel.

Starting with the stern, first the height and rake of the stern post, and the width of the wing transom were determined. The *Regimentos* defined 26 *palmas* (665.2 cm) for the



height of the stern post and a rake of 8 *palmos* (204.8 cm).<sup>459</sup> The *Regimentos* unfortunately skipped the width of the wing transom, perhaps due to a writer's lapse. To solve this gap, a 30 *palmos* (768 cm) width was extrapolated from the relation of the widths of the other frigates described in the *Regimento*. With this information it was possible to ascertain the 'box' within which the stern panel fit.

The shape of the transom was another matter to be settled. The stern panel, when highly decorated, served in a political capacity as a monument to the greatness of the contractor. The contractor, or owner of a ship, was not always the crown; it could also be a private nobleman or one of Europe's East Indies companies. Although ship decoration did change substantially according to fashions of the time and the personal tastes and wealth of the contractor, Anderson stated that each nation maintained a specific stern shape, and in his article presented the following panels' shapes for four European nations (Fig. 68).<sup>460</sup>

---

<sup>459</sup> Pona 1890, 221-2.

<sup>460</sup> Anderson, 1928, 44.

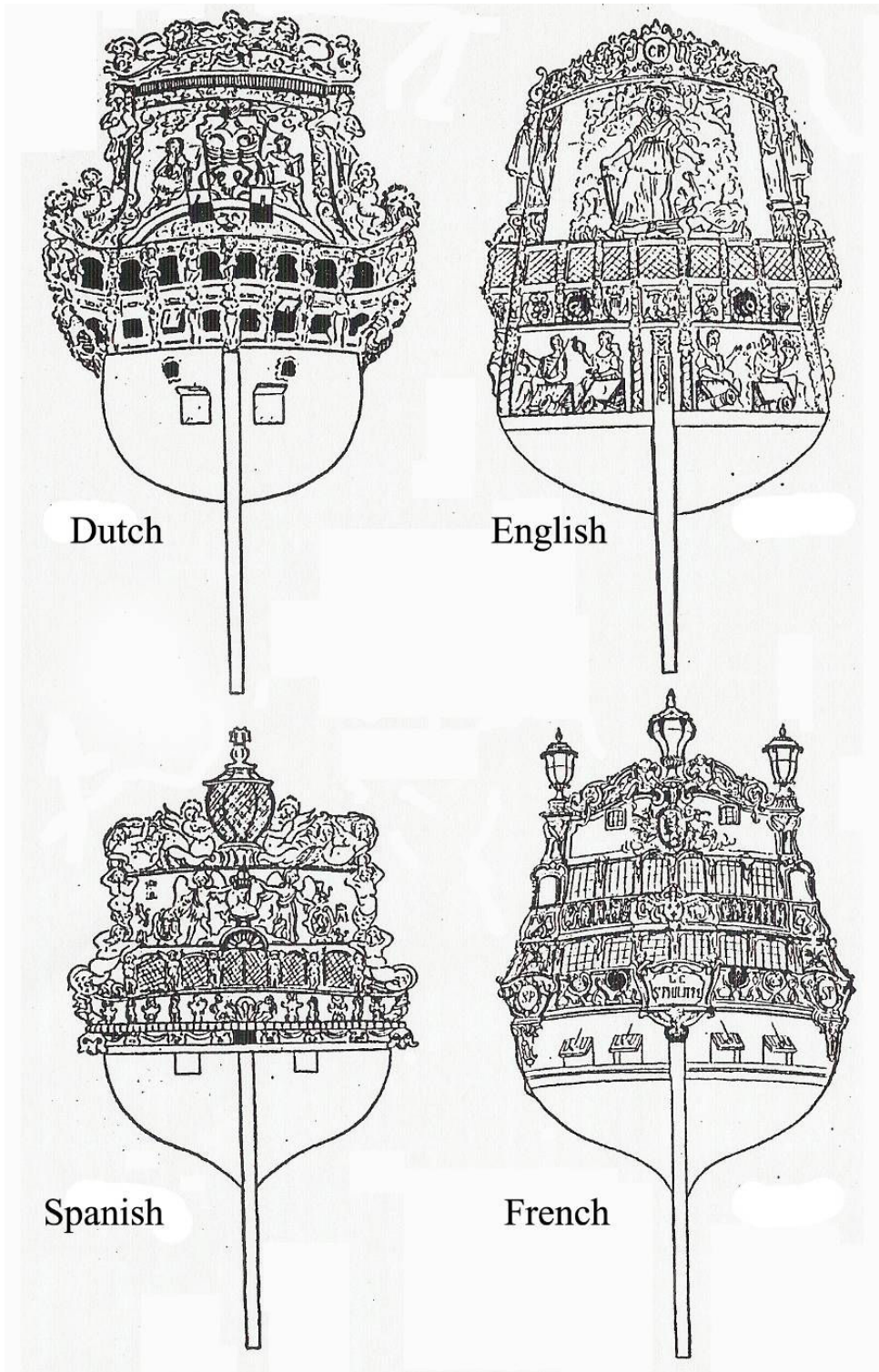

Fig. 68. European panel shapes. (After Anderson 1928, 44)

Unfortunately, Anderson did not include a Portuguese example, probably because no seventeenth century Portuguese iconography is known to have survived. One maritime expert who has studied the Portuguese Navy of seventeenth to nineteenth centuries indicated that the Portuguese stern panel was as rounded as the English during the eighteenth century.<sup>461</sup> Although it is possible that this stern shape could also have been in use in earlier centuries, the stern panel in this study of *Santo Antonio de Tanná* was set as a diagonal V; no information, historic or otherwise, was found to prove or dispute this choice (Fig. 69).

Several carvings located in the stern of the wreck were believed to be part of the highly decorated stern panel (Fig. 70 and Fig. 71).<sup>462</sup> Since *Santo Antonio de Tanná* was a *nau capitania* (flagship) its stern decoration would probably be an equal in aesthetics and wealth to the finest contemporaneous European vessels.

---

<sup>461</sup> Commander Rodrigues Pereira, personal communication January 2006.

<sup>462</sup> Robyn Piercy, personal communication June 2005.

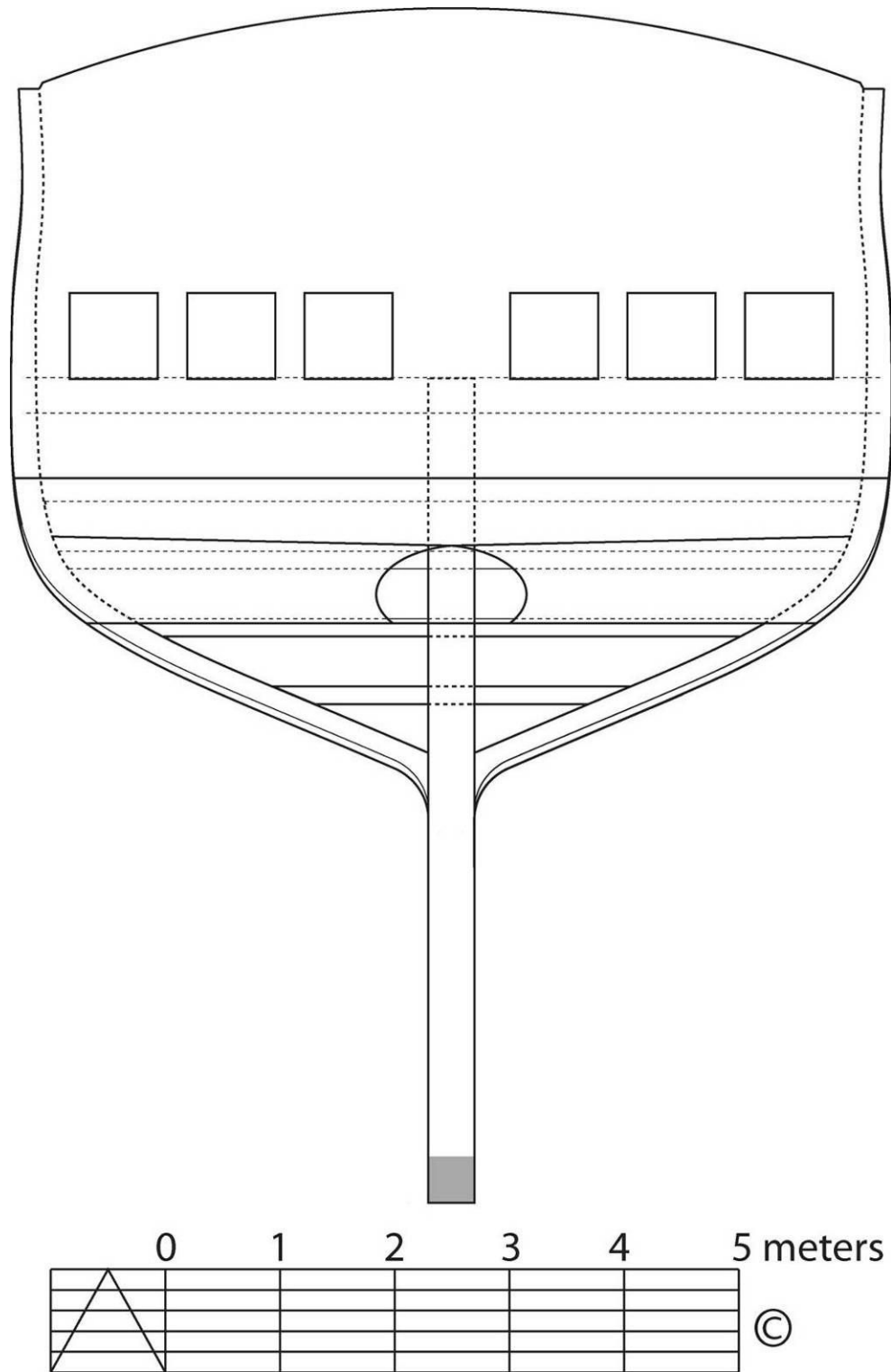

Fig. 69. Stern panel of *Santo Antonio de Tanná*..



Fig. 70. A wooden angel that decorated the stern of the *Santo Antonio de Tanná*. (Courtesy Robin Piercy)



Fig. 71. Wooden statue of a small boy recovered from the stern. (Courtesy Robin Piercy)

In contrast to the stern, in the bow no archaeological remains survived, therefore all reconstruction work was based on historical sources. The reconstruction questions related to the bow were the dimensions of the bow, the shape of the bow, and the beak head type. The bow dimensions were determined using the *Regimentos* information, which stated that the stem should be 26 *palmos* (665.6 cm) in height with a rake of 20 *palmos* (512 cm). The vertical shape of the bow was defined by the understanding that in the seventeenth century bows were based on compass curves.<sup>463</sup> Portugal did not differ from this.<sup>464</sup> The curvature of *Santo Antonio de Tanná*'s stem was the compass curve of 20 *palmos* (512 cm), with the addition of a straight line where the curve would start to arch backwards.<sup>465</sup>

The design and assembly beak head was a challenge. As was the case with the stern panel, the shape of the beak head depended more on political and aesthetical reasons than maritime or architectural imperatives. Studies at the Portuguese archives did not produce any hypothesis for the type of decoration used in ships constructed by the India's viceroyalty. Although the true features of *Santo Antonio de Tanná* were impossible to identify, the reconstruction created a beak head with aesthetical and architectural similarities to the general preferences of the time, based on the Keltridge

---

<sup>463</sup> Lavery 1984, 7-8.

<sup>464</sup> Oliveira 1981, 90-2.

<sup>465</sup> Oliveira 1981, 90-2.

drawings, paintings of English and French late seventeenth-century vessels and Chaillé drawing (Fig. 72).<sup>466</sup>

The combination of archaeological sources, historical sources, and iconography (scanty through it was) allowed for a tentative reconstruction of the frigate's lines (Fig. 73 to Fig. 76). Even though this reconstruction was not able to pinpoint the specific decorations and the precise architectural signatures of this vessel, the lines drawings do provide a basis for further analysis of the ship.

#### Reconstructed scantlings

Having projected a theoretical hull shape, the next required stage in the reconstruction was to have an understanding of the physical components that would compose that theoretical hull. That is, it was necessary to move from the ship plans to the actual ship. From a compilation of archaeological, iconographic, and written evidence the following scantling list of *Santo Antonio de Tanná* was proposed. The structure of the scantling list was based on the *Relação Dos Nomes das peças da Construção Dos Navios e das madeiras do Brasil próprias para elas*.<sup>467</sup>

---

<sup>466</sup> Catalogue 1997; see also Bodriout 1993, 27.

<sup>467</sup> See chapter VI, 84-5.



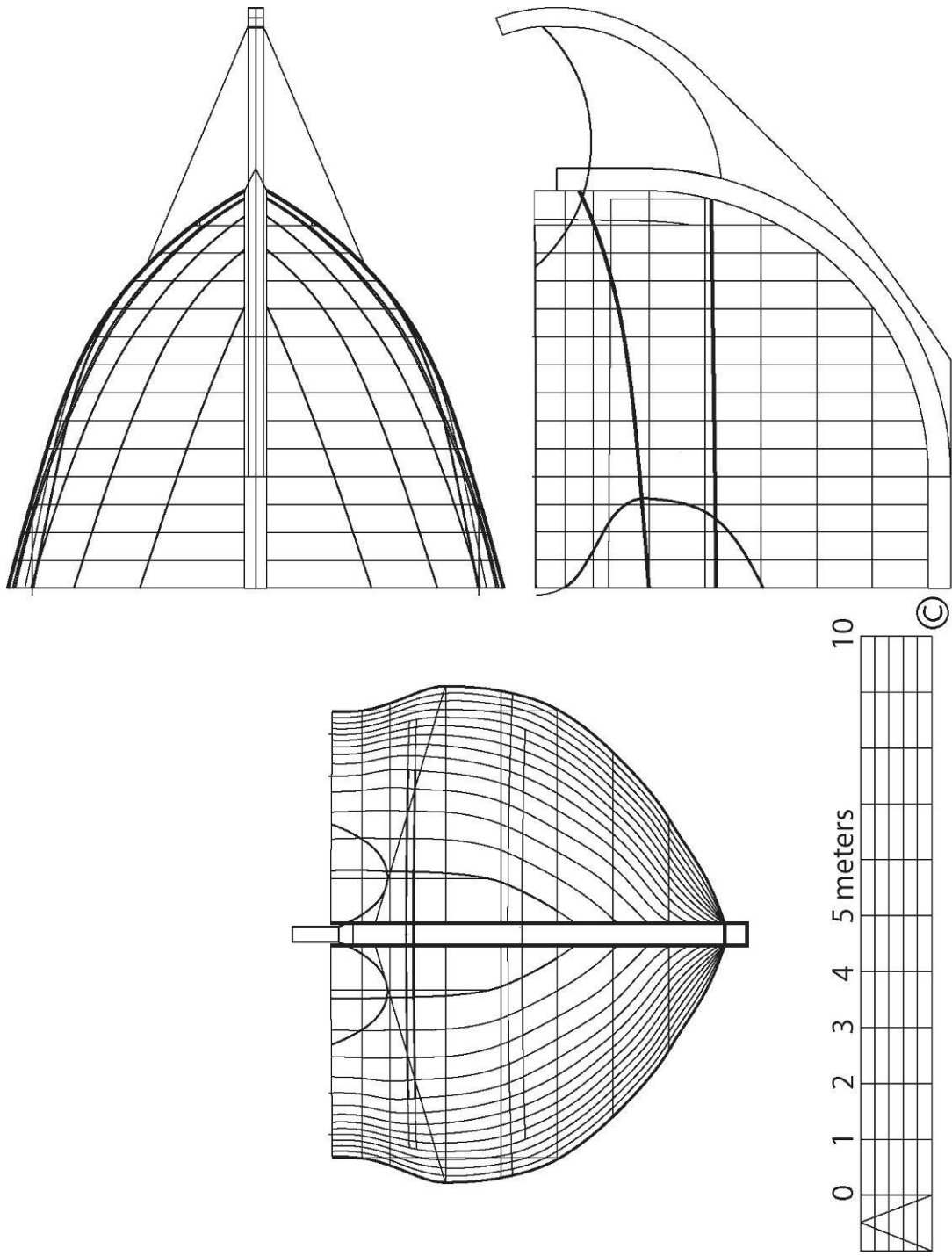

Fig. 72. *Santo Antonio de Tanná* bow.

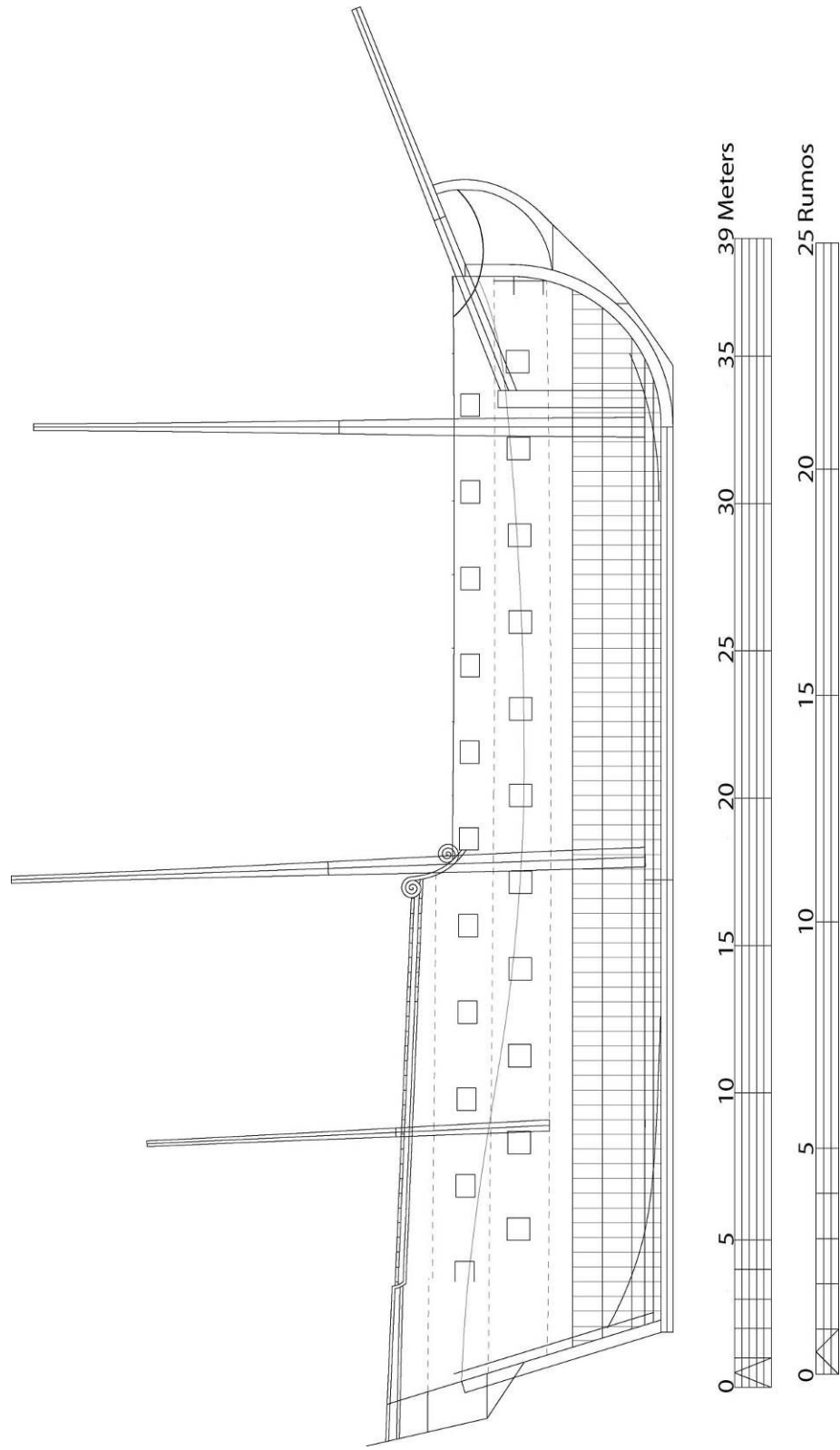

Fig. 73. Sheer plan of the *Santo Antonio de Tanna*, 42-gun version of the 1680s.

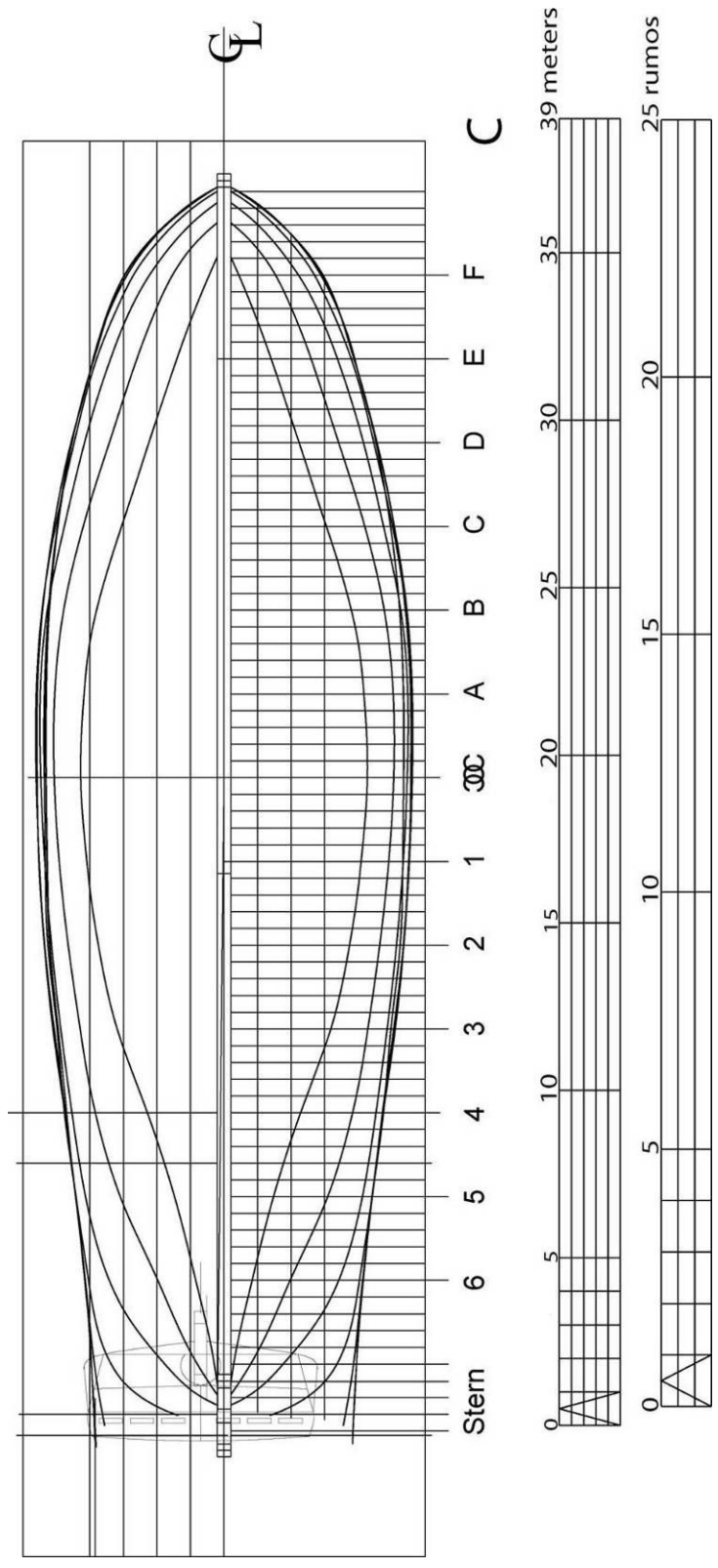

Fig. 74. Full breadth plan of the *Santo Antonio de Tanná*, 42-gun version of the 1680s.

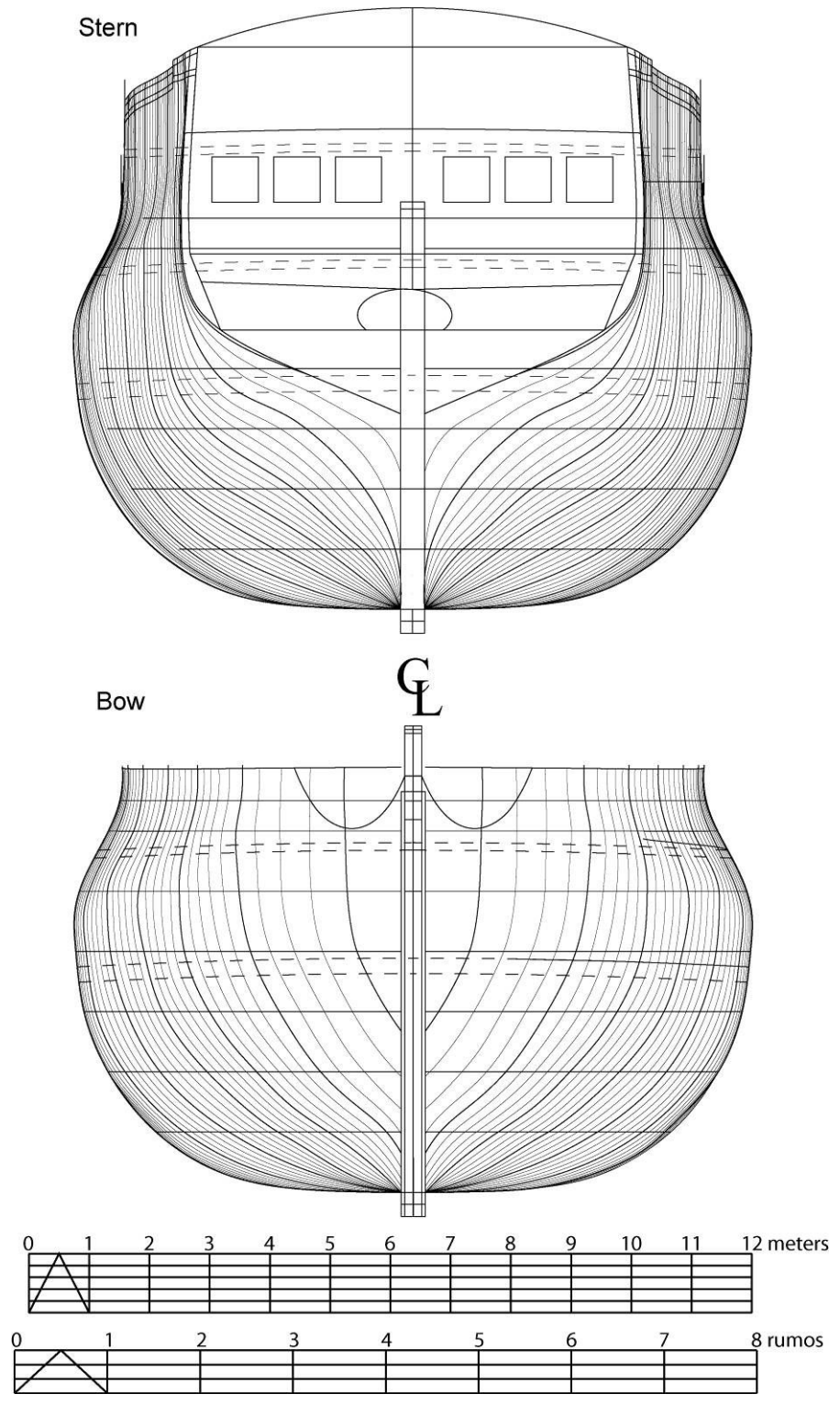

Fig. 75. Bow and stern body plans of *Santo Antonio de Tanná*.

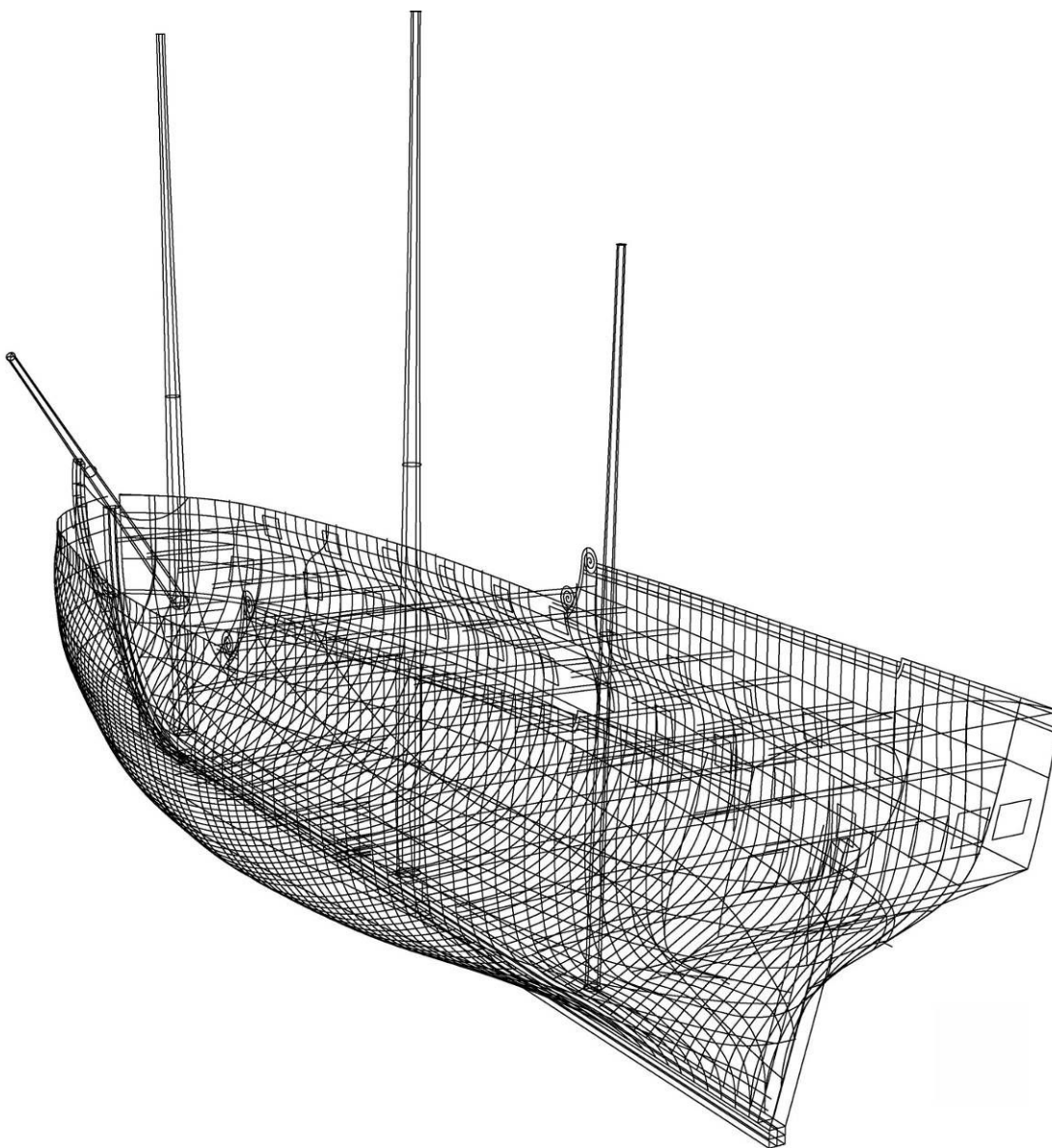

Fig. 76. *Santo Antonio de Tanná* tridimensional tentative lines drawings.

### Keel

The first piece of the ship laid down in the shipyard was the keel. It was a challenge to find the size of the keel because even though it was present in the site, its remains were

not studied. For its length, an estimate of 30 m was initially given by Thompson.<sup>468</sup> Jordan derived from the *Regimentos* estimates that this ship would have a 20 *rumos* keel, equal to 30.72 m in length.<sup>469</sup> Based on the Jordan estimates, the keel in the reconstruction was 30.72 m. However, following the location of the master frame in the photographic record and readjusting the site plan according to the new length of the ship, the hull appeared to have an additional 70 cm more than initially supposed, which led to an estimated keel length of 20 to 21 *rumos* (30.72 m to 32.25 m). Neither the shape of the keel nor the number of pieces that composed its length could be ascertained. It was unfortunate that the keel could not be studied as this is an important part of a ship's construction and all the proportions of a Portuguese ship were determined in relation to the length of the keel. If the keel had been recovered the discussion about the dimensions would have gone from academic to certainty. The keel is presently believed to have a square section of 40.1 cm on a side based upon the stern post being 40.1 cm square (Fig. 77).

---

<sup>468</sup> Thompson 1988, 26.

<sup>469</sup> Jordan 2001, 311-14.



Fig. 77. Keel and ends of the vessel.

### False keel

Located beneath the keel, the false keel consisted of a layer of sacrificial planking. Since no evidence was available, it was not included in the model. It is mentioned only because it appeared in the *Relação Dos Nomes das peças da Construção Dos Navios e das madeiras do Brasil próprias para elas*.

### Stem

Nothing of the stem was known to have survived. The information used for the reconstruction came from other sources. The shape of the post was, as stated above, derived from the *Regimentos* height and length instructions. For the other dimensions, the stem was given the same square section, 40.1 cm, which was recorded in the stern post (Fig. 78). It is likely, however that the leading edge of the stem was narrower than the after (rabbeted) edge

### Stemson

The stemson was an interior timber that reinforced the join of the keel and stem. A piece was placed where this type of hull element is typically found; again, no information was available (Fig. 78).

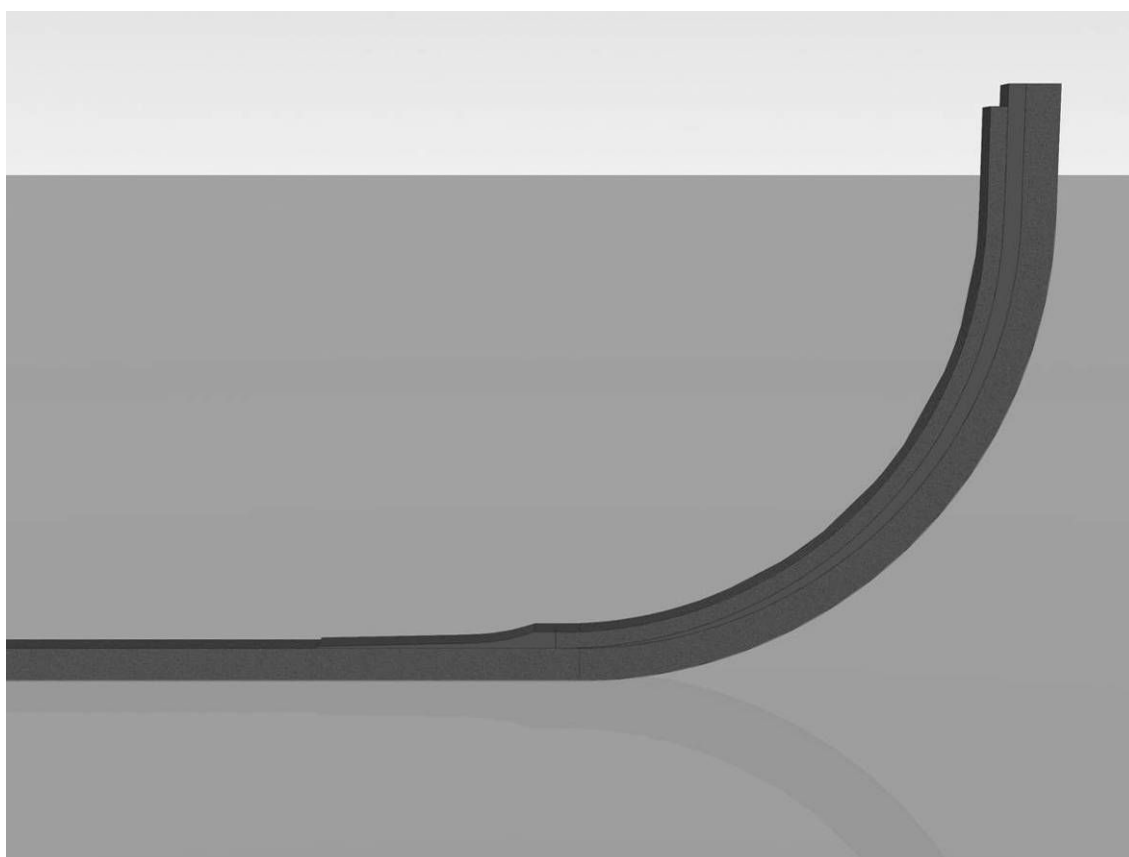

Fig. 78. Stem assembly of vessel showing the keel, stem and stemson.



### Stern post

The heel of the stern post was believed to have survived atop the after end of the keel.<sup>470</sup> Unfortunately, besides the moulded and side dimensions, the amount recorded in the archaeological campaign was insufficient to have yielded much else. The reconstruction of the rake of the stern post and its height come from the *Regimentos*. One small detail was that when testing the steering elements in the model, it appeared that the stern post needed to be 1 or 2 *palmas* (25.6 cm or 51.2 cm ) higher; this is because the midsection was raised 1 *palmo* (25.6 cm) and this placed the tiller in the middle of the between deck space instead of near the underside of the next deck. As no information was found that could explain the correct position of the tiller on a seventeenth century frigate, the ship model was not corrected.

Three timbers forward of the stern post existed and reinforced and supported the upper stern structure. The first, shorter than the rest, received and supported the fashion pieces and is notched for that purpose; the moulded dimensions are the same as those of the stern post (40.1 cm) and the sided dimensions were 25.6 cm. The second post had the same height as the sternpost and served to lock several pieces in place; its sided and molded dimensions (25.6 cm and 40.1 cm respectively) were derived from the site plan. The third timber (of same dimensions as the second) existed to receive the heels of five Y frames that fill the narrow space where the stem tapes to the rudder.

---

<sup>470</sup> See Chapter VIII, 129-30.

### Deadwood knee

The *coral* was a type of deadwood knee that reinforced the union of the sternpost with the keel of Portuguese ships. Because the ship was not fully excavated the existence of this piece cannot be proved or disproved. However, the *coral* was one of the archaeological signatures of Iberian shipbuilding known from the fourth to the nineteenth century and was included in the model (Fig. 79).<sup>471</sup>

### Transom

The transom was composed of several components: the wing transom, the other transom pieces, the fashion pieces, and the counter timbers (Fig. 80).

For the wing transom, the *Regimentos* only mention that it was twice the size of the others transom pieces. As stated before, the width of 30 *palmas* (768 cm) for the wing transom was established by extrapolating the widths of the other frigates mentioned in the *Regimentos*, while the moulded and side dimensions were inferred from French sources.<sup>472</sup> According to the *Construction du Roy*, these dimensions should have been a square in between 15 French inches (16 *polegadas*, 40.96 cm) and 16 French inches (17 *polegadas*, 43.52) corresponding to two-thirds of the width of the floor of the master frame.<sup>473</sup> Following the first 16 *polegadas* (40.96 cm), the size of the transom was

---

<sup>471</sup> It is seen in the majority of Portuguese wrecks (Alves 2001) and it is one of the sixteenth century characteristics that Oertling (2001, 236) presents.

<sup>472</sup> Pona 1890, 220-3.

<sup>473</sup> Lafon 1695, 42 and 57.

disproportional to the ship; when the two-thirds rule was applied the main transom was reduced to 12 *polegadas* (30.72 cm) and this blended more accurately with the proportions of *Santo Antonio de Tanná*. The other transom pieces were six *polegadas* (15.36 cm) square following the *Regimentos* recommendations that they should be half the wing transom size.<sup>474</sup>

The fashion pieces had a square section of 25 cm, determined from the archaeological measurements of the filler pieces in the stern. The fashion pieces needed to be unusually large to withstand the strain of the hull planking that was inserted into recesses cut in the fashion pieces; the planks naturally wanted to spring out from their curved state and needed a very strong piece to keep them in place. However, when the fashion pieces were placed in the model they looked wrong. Further research in iconography and written sources indicated that tapering these pieces was common in ships of the seventeenth century. The problem was that no measurement information was available to make the tapering, the fashion pieces started in the bottom with a square section of 25 cm and tapered to a square section of seven *polegadas* (17.92 cm); this tapering was based on an educated guess (Fig. 80).

---

<sup>474</sup> Pona 1890

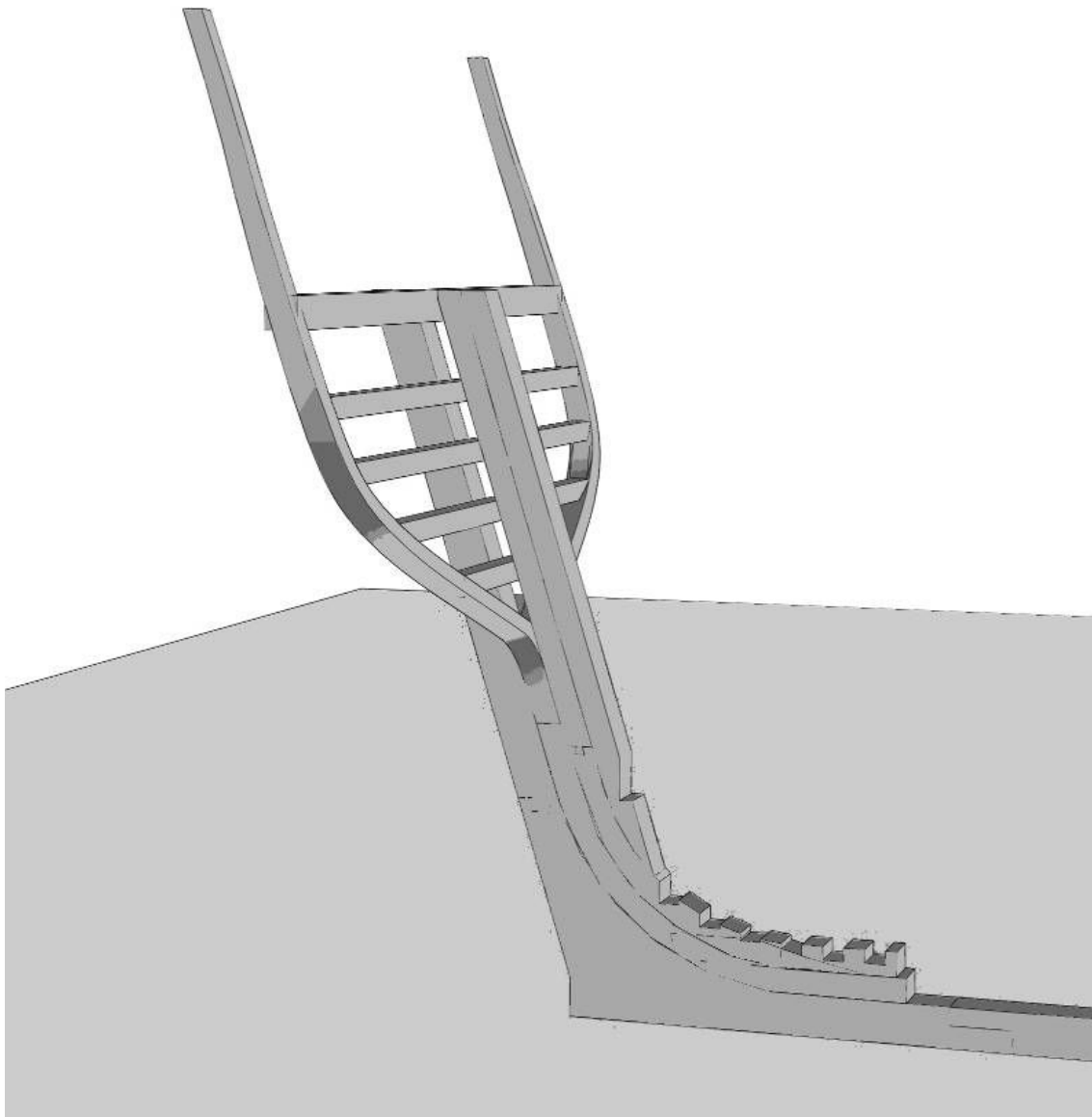

Fig. 79. Stern area of the vessel.

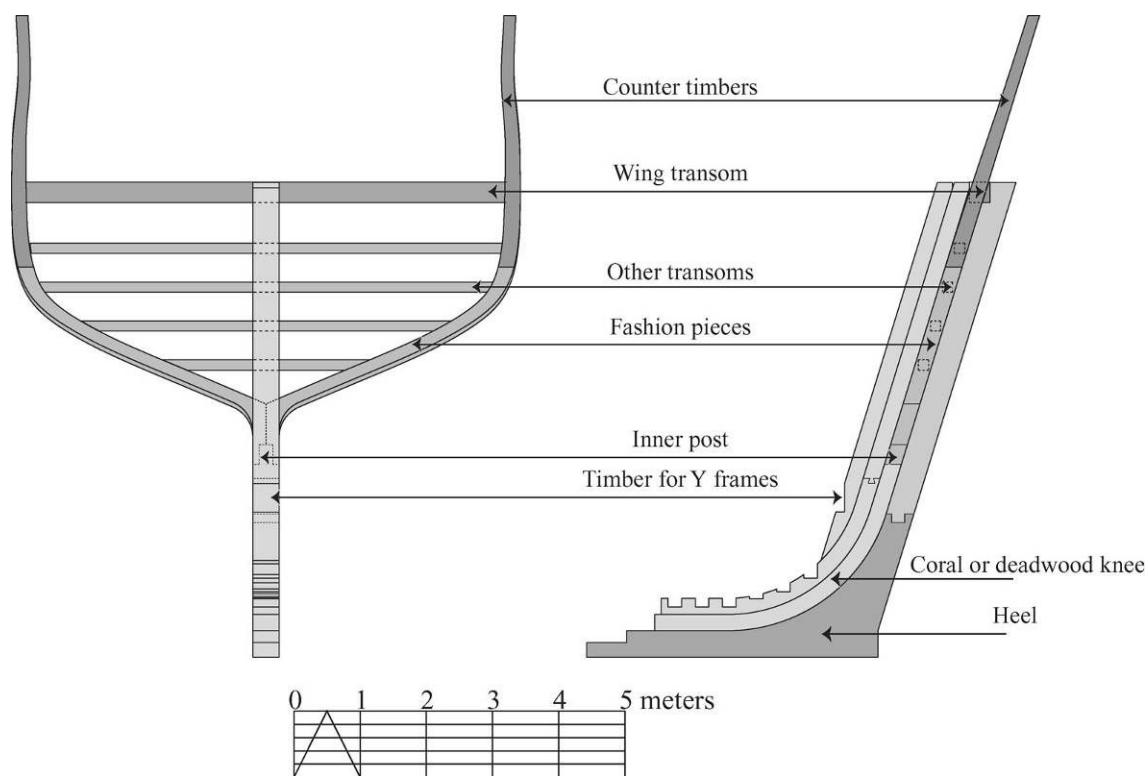

Fig. 80. Stern area of the vessel with pieces labeled.

### Frames

The framing pattern, discussed in the previous chapter, indicated that frames were spaced 8 *polegadas* (20.48 cm) apart and each was composed of a floor, a pair of first futtocks, a pair of second futtocks, a pair of third futtocks, and in the stern, two fourth futtocks. Following this pattern, the reconstruction model had a total of 84 full frames and eight half-frames. They were divided in three frames slotted in the inner stern post, 42 frames aft of the master-frame, and 30 forward. The bow had eight cant frames and eight half frames fitted between the cant frames. The bow and the forward most frames did not survive, and cant frames were included since the time span is close to the

introduction of these structural elements. This makes for a very weak bow that could have had half frames placed in the gaps to strengthen the ship so eight half-frames were added. The absence of coherent bow remains on the wreck could indicate that this was a weak bow and did not survive for that reason. If the few cant frames deteriorated with the passing of time the half frames would have lost their support and fallen from their place.

In the stern area, the inclination of the stern post and the position of the frames atop the deadwood strongly suggested the continuation of framing aft, attached to the inner stern post, so five frames were added to fill the gap.

The next figures show the framing pattern (Fig. 81), the master-frame (Fig. 82 and Fig. 83), three frames forward, and three aft the master frame. The frames forward were frame 15 (Fig. 84 and Fig. 85), showing a typical frame, frame 30 the last frame before the cant frames of the bow (Fig. 86 and Fig. 87), and the first cant frame of the bow (Fig. 88 and Fig. 89). The frames aft were frame 20 (Fig. 90 and Fig. 91), a typical frame, frame 35 the last frame that rests on the keel (Fig. 92 and Fig. 93), and frame 39 one of the frames that was slotted in the stern assembly (Fig. 94 and Fig. 95).

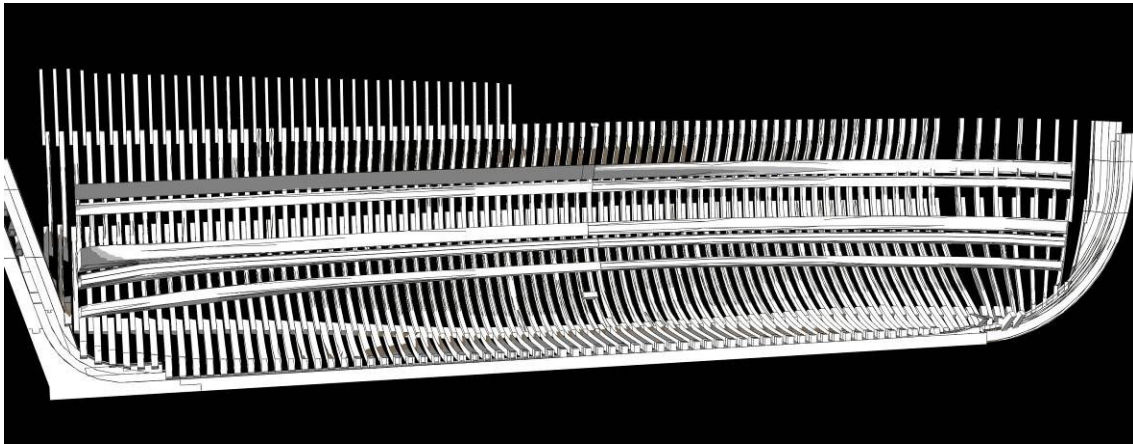

Fig. 81. Framing pattern of the *Santo Antonio de Tanná*.

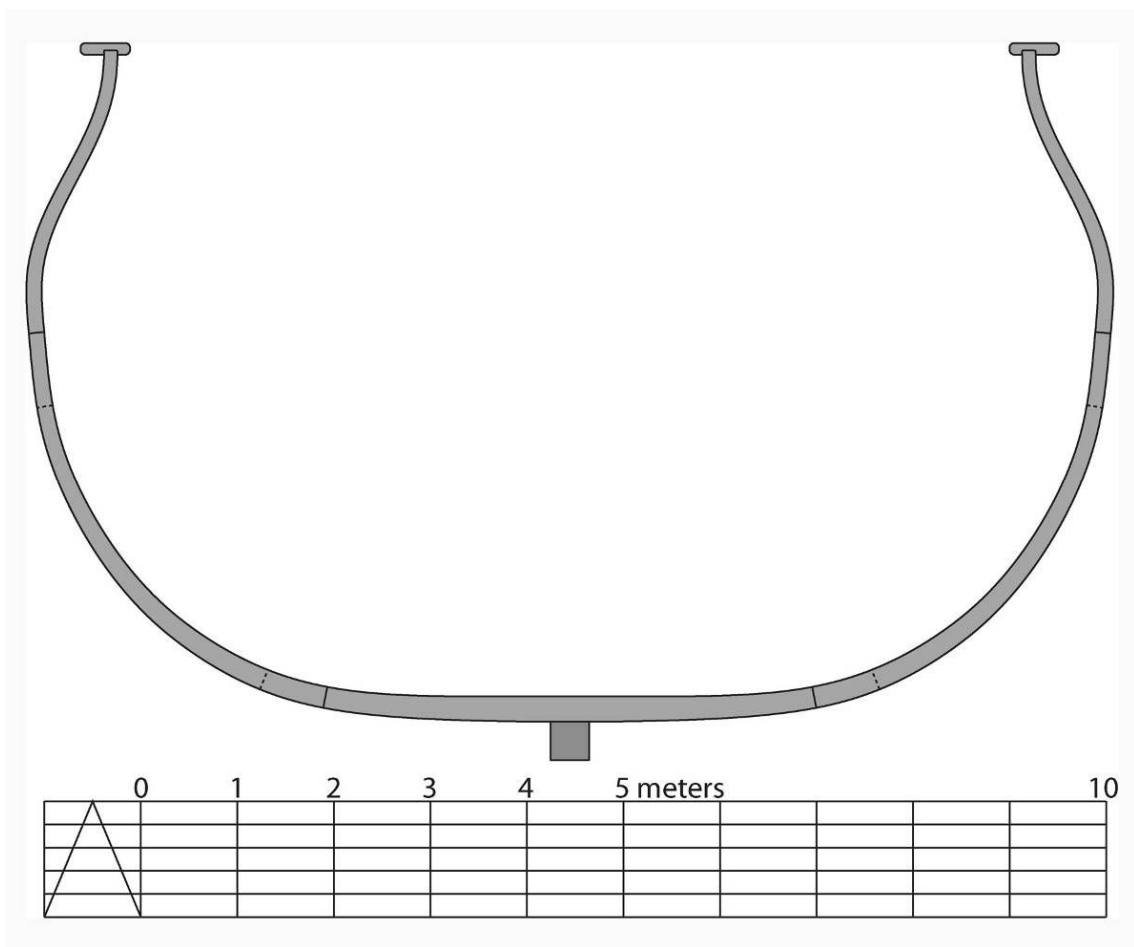

Fig. 82. Section of *Santo Antonio de Tanná*'s hull at the master frame.



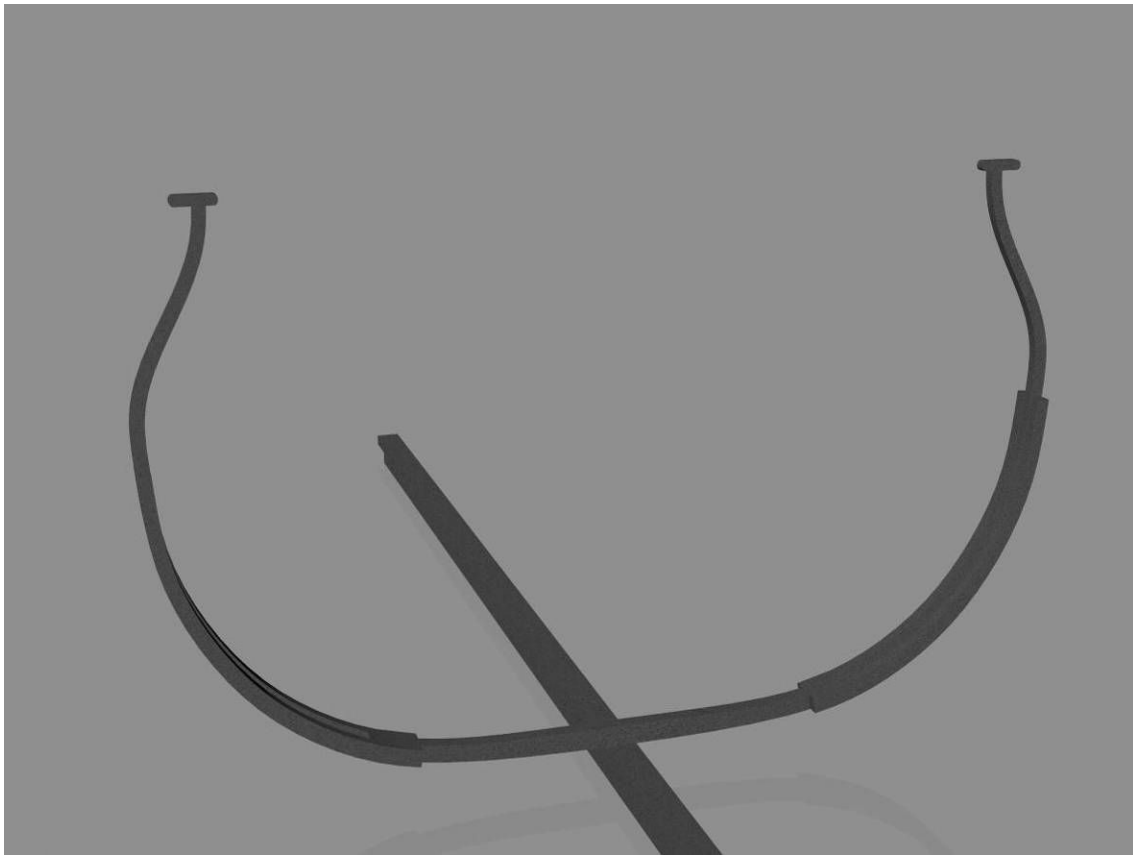

Fig. 83. Three-dimensional view of the master-frame on the keel.

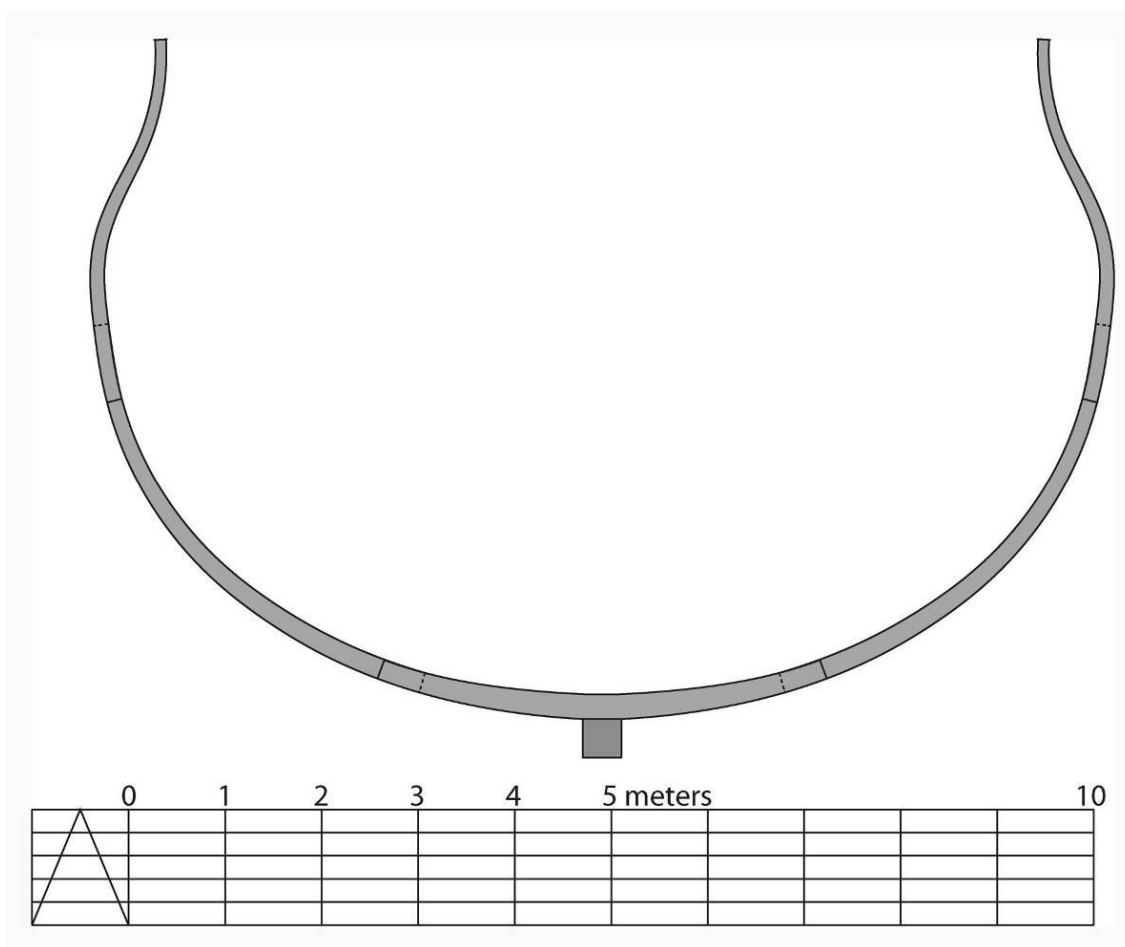

Fig. 84. Section of *Santo Antonio de Tanná*'s hull at the frame15 forward.

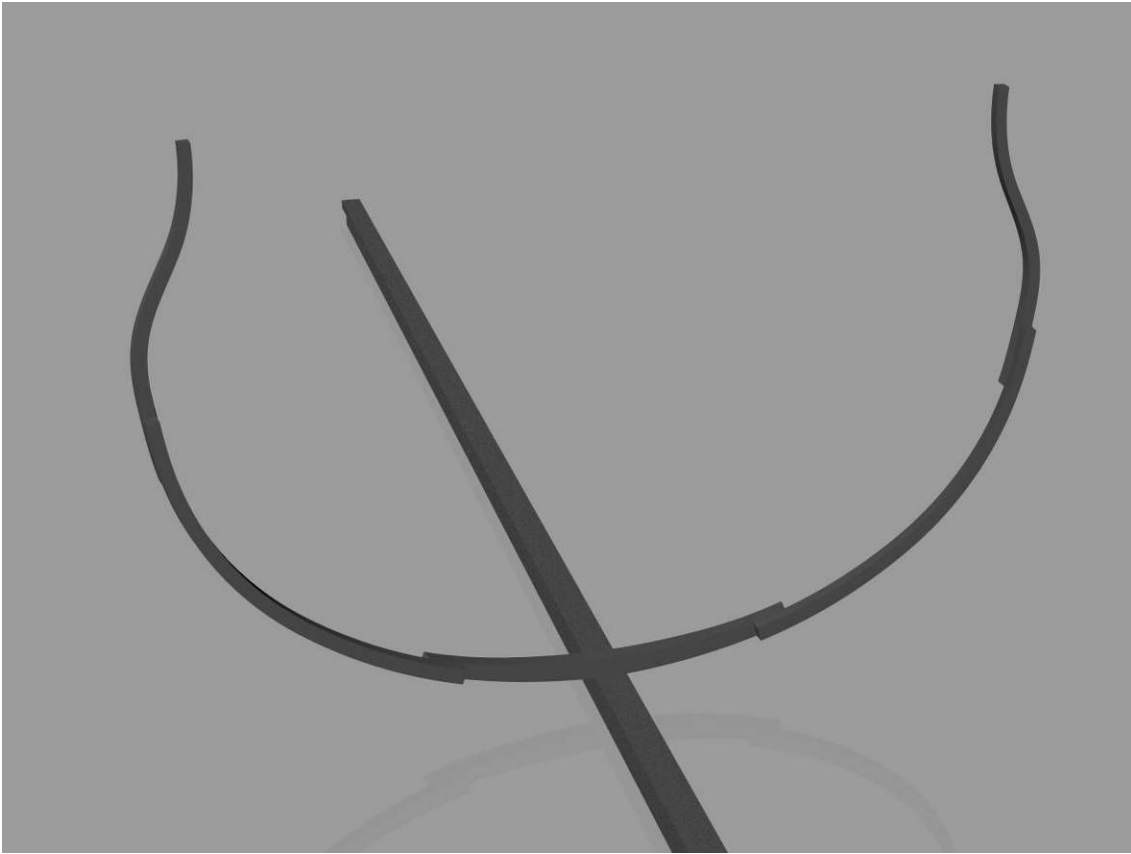

Fig. 85. Three-dimensional view of frame 15 forward on the keel.

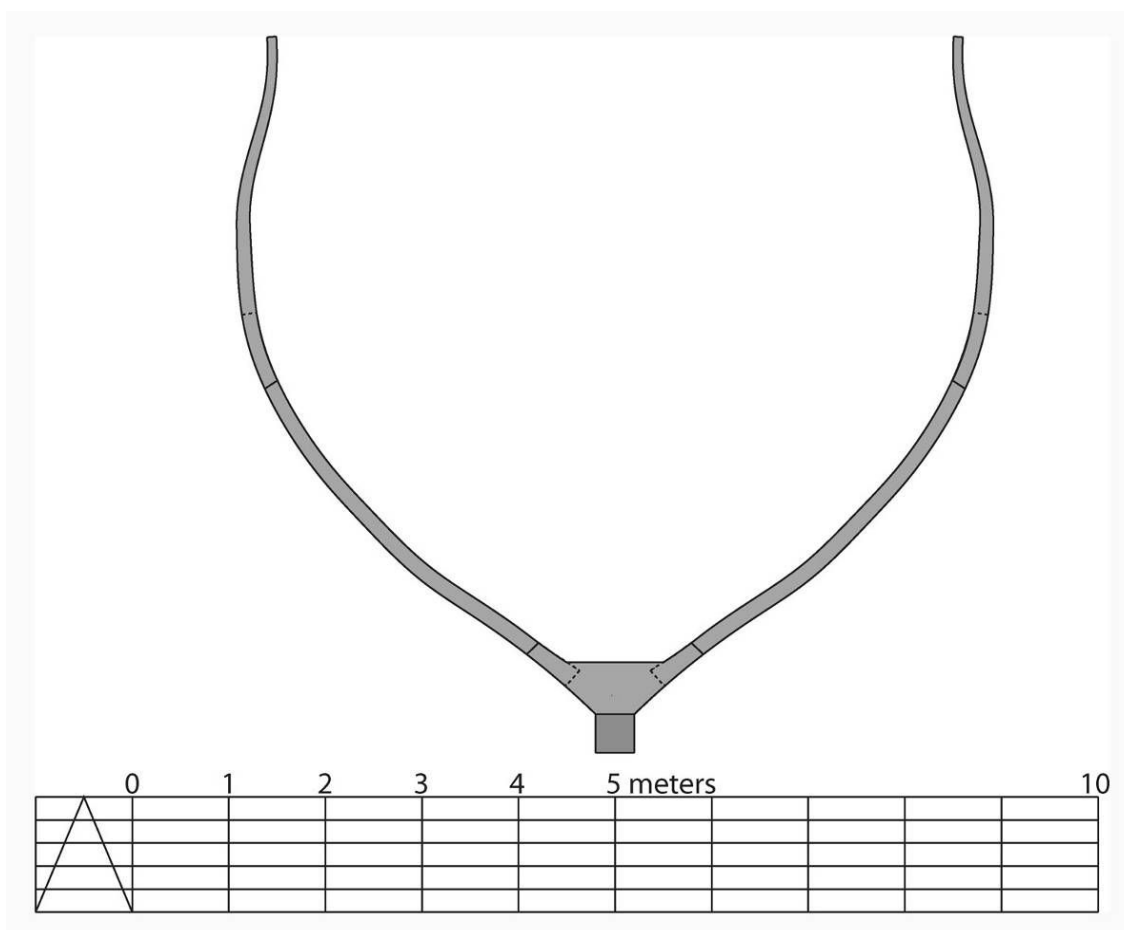

Fig. 86. Section of *Santo Antonio de Tanná*'s hull at the frame 30 forward.

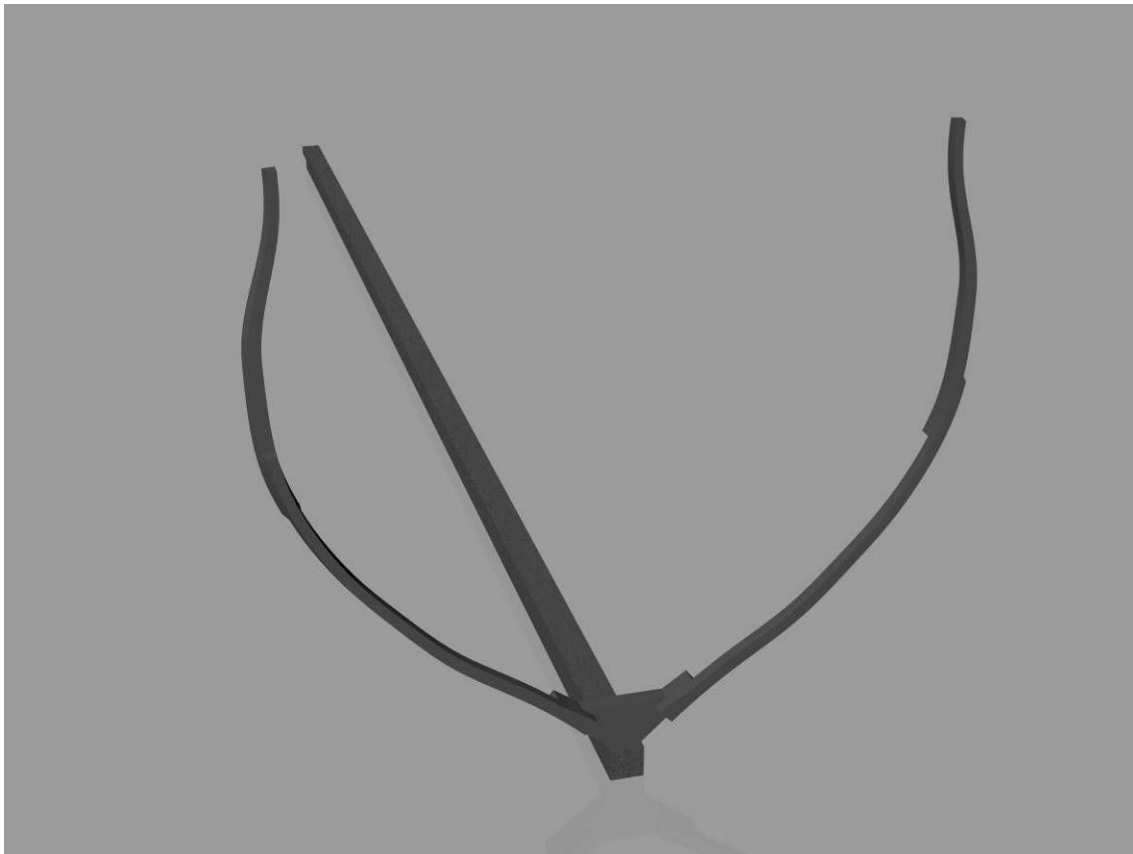

Fig. 87. Three-dimensional view of frame 30 forward on the keel.

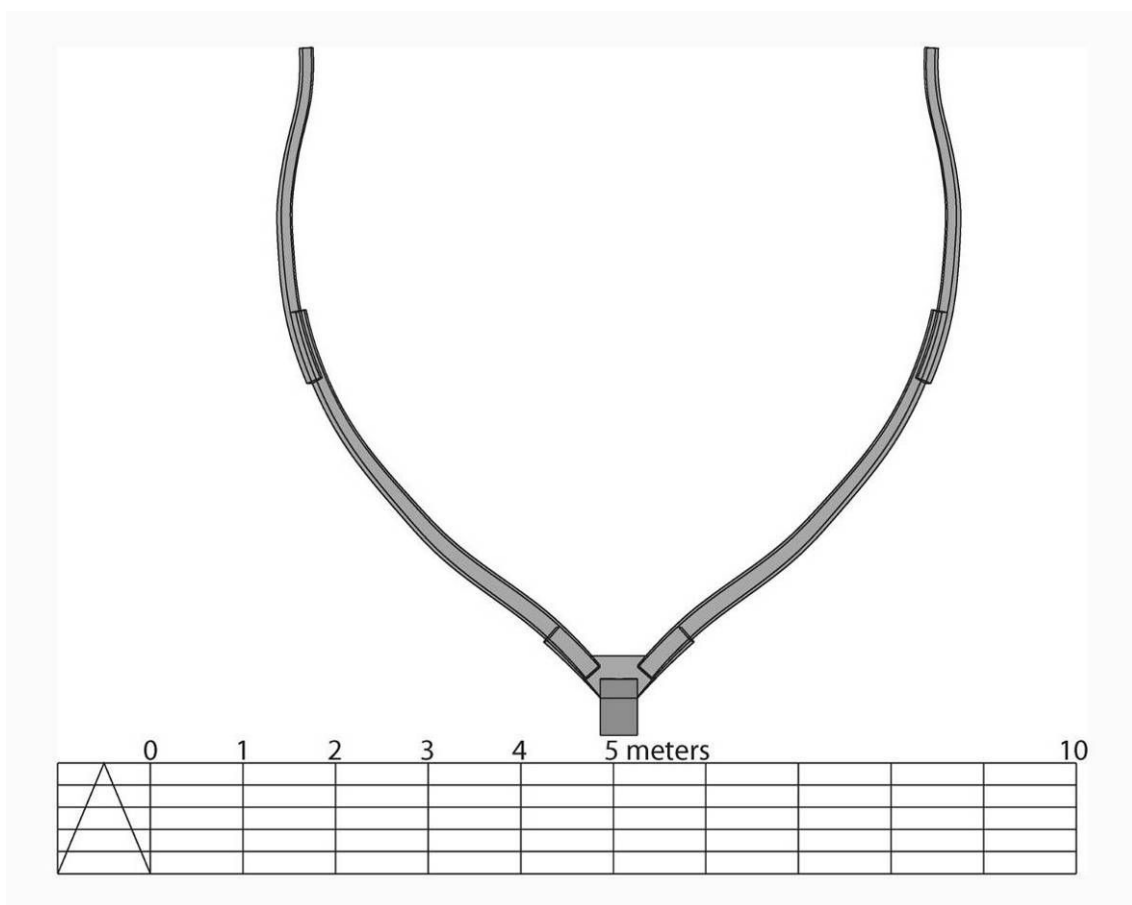

Fig. 88. Section of *Santo Antonio de Tanná*'s hull at the frame 31 forward, cant frame.

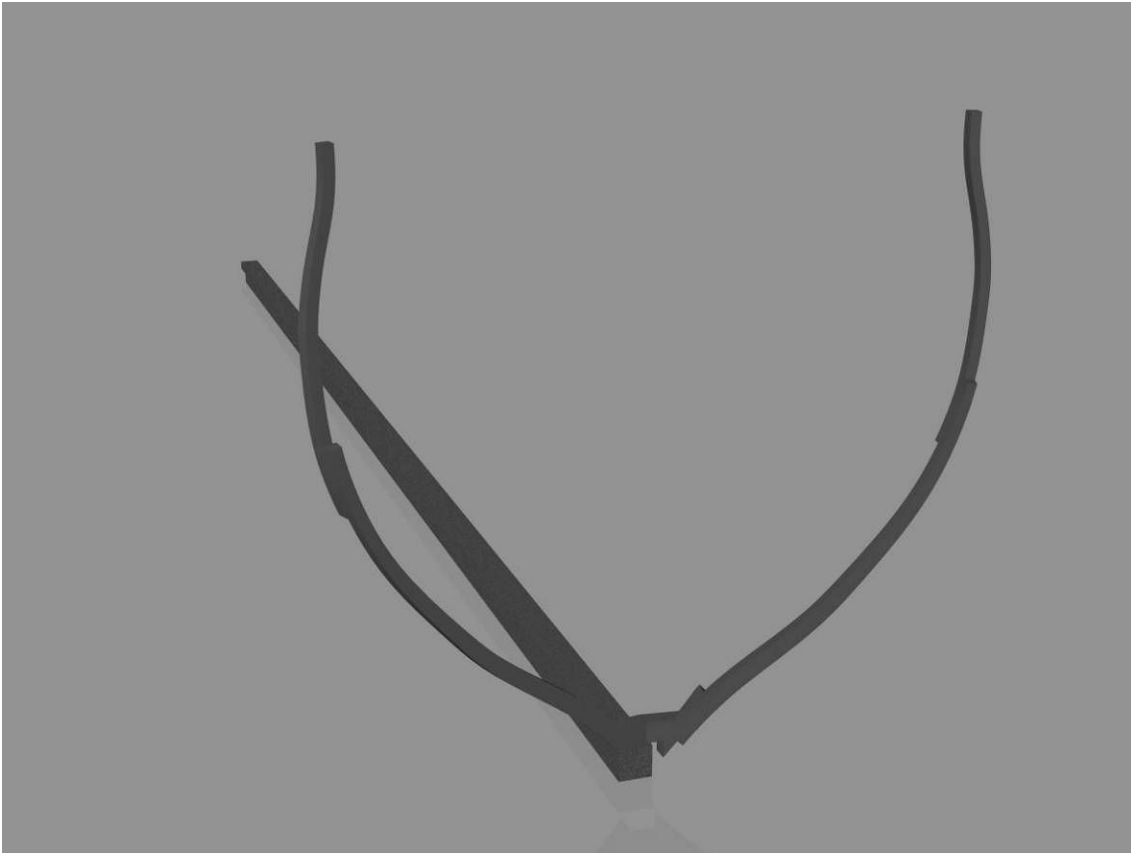

Fig. 89. Three-dimensional view of frame 31 forward, cant frame on the keel.

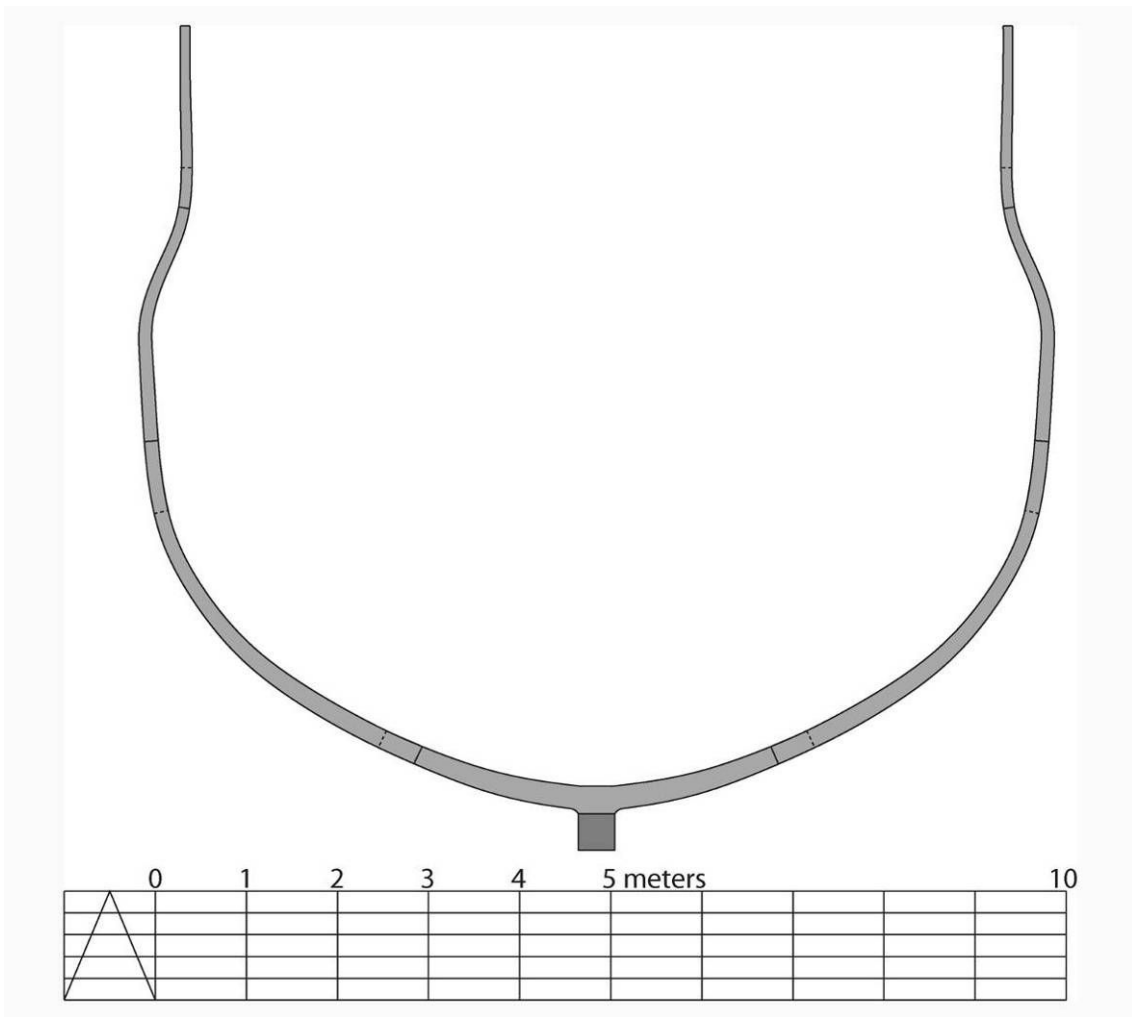

Fig. 90. Section of *Santo Antonio de Tanná*'s hull at the frame 20 aft.



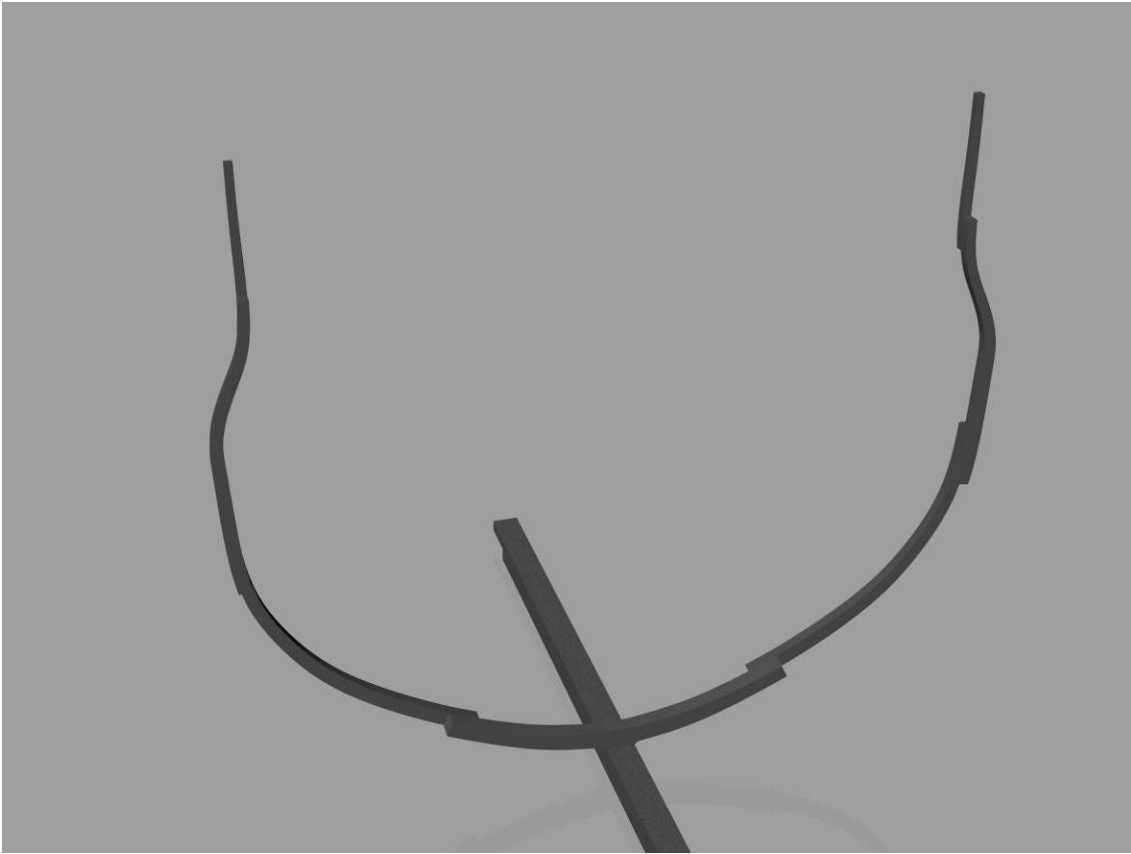

Fig. 91. Three-dimensional view of frame 20 aft on the keel.

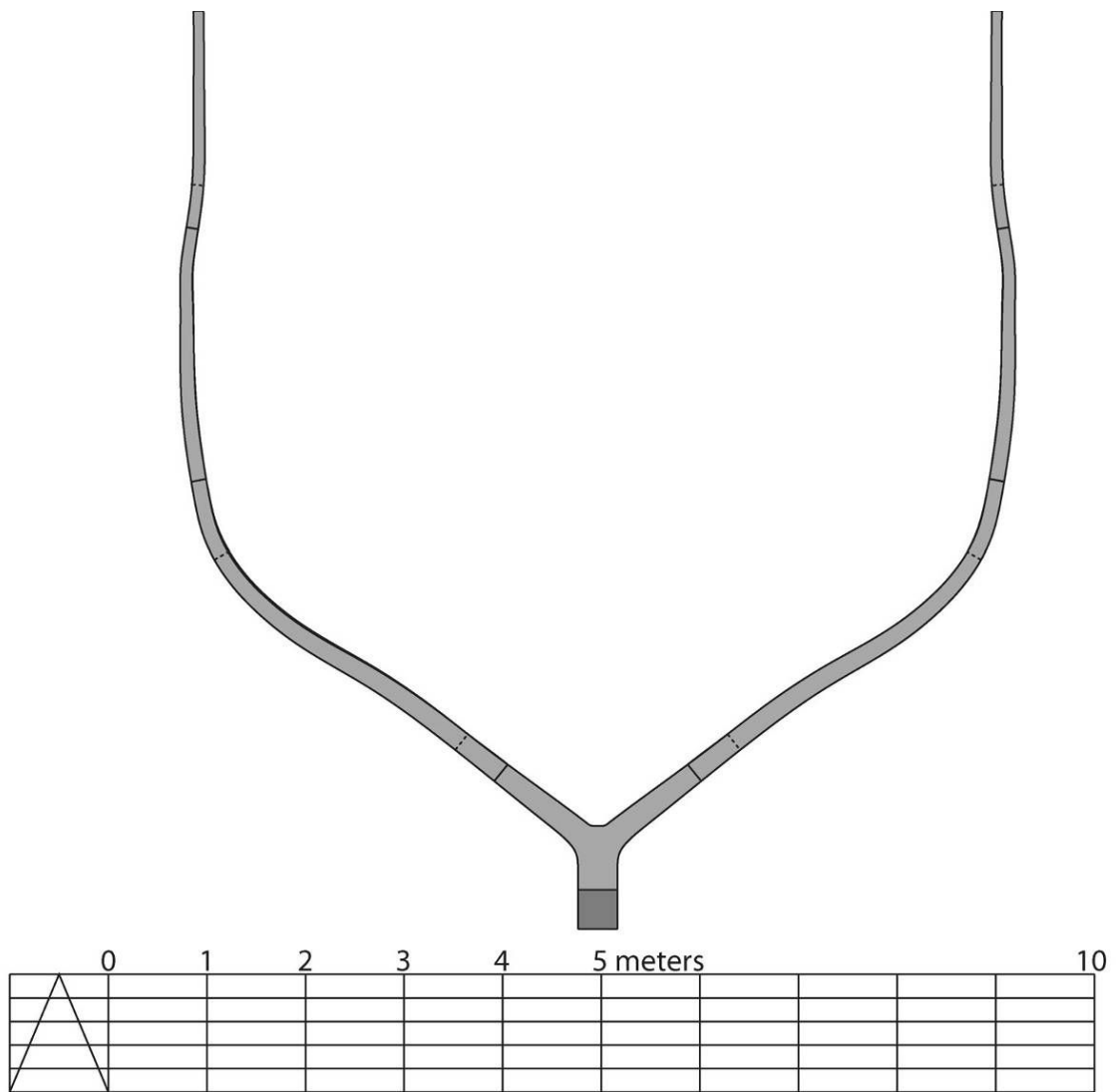

Fig. 92. Section of *Santo Antonio de Tanná*'s hull at the frame 35 aft.

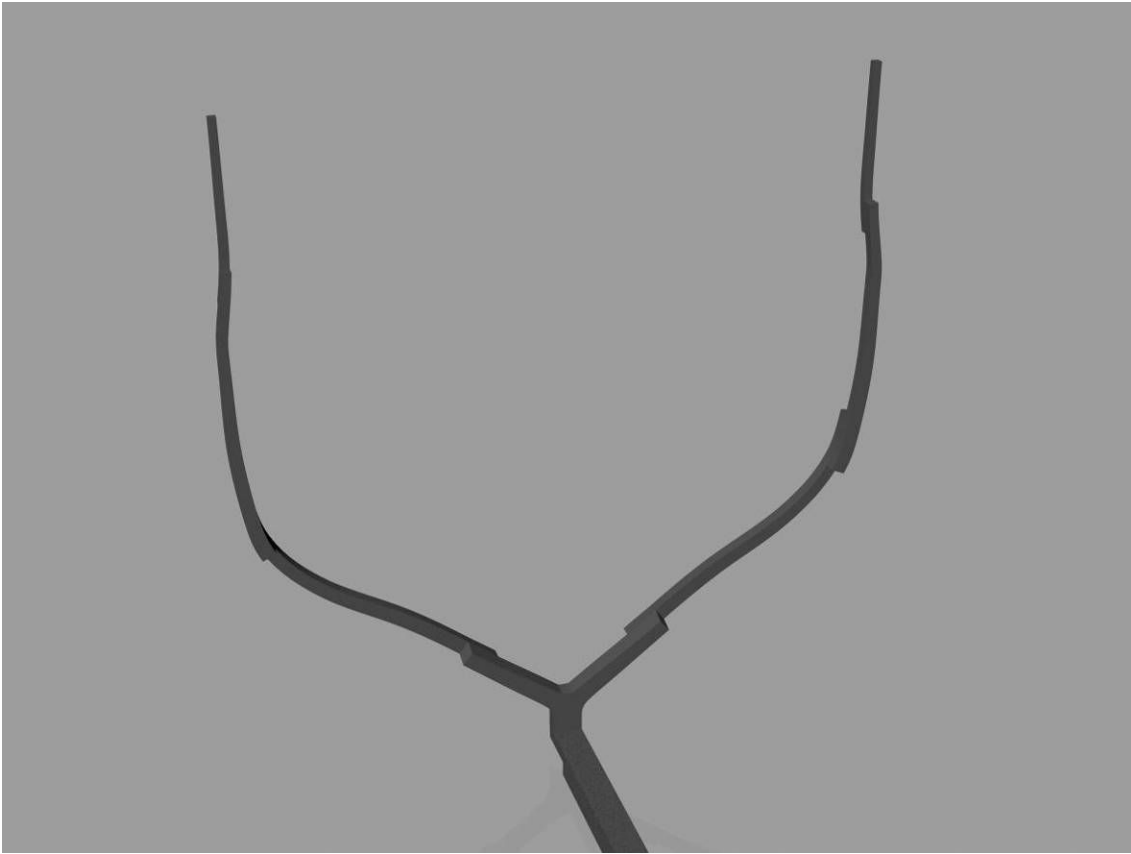

Fig. 93. Three-dimensional view of frame 35 aft on the keel.

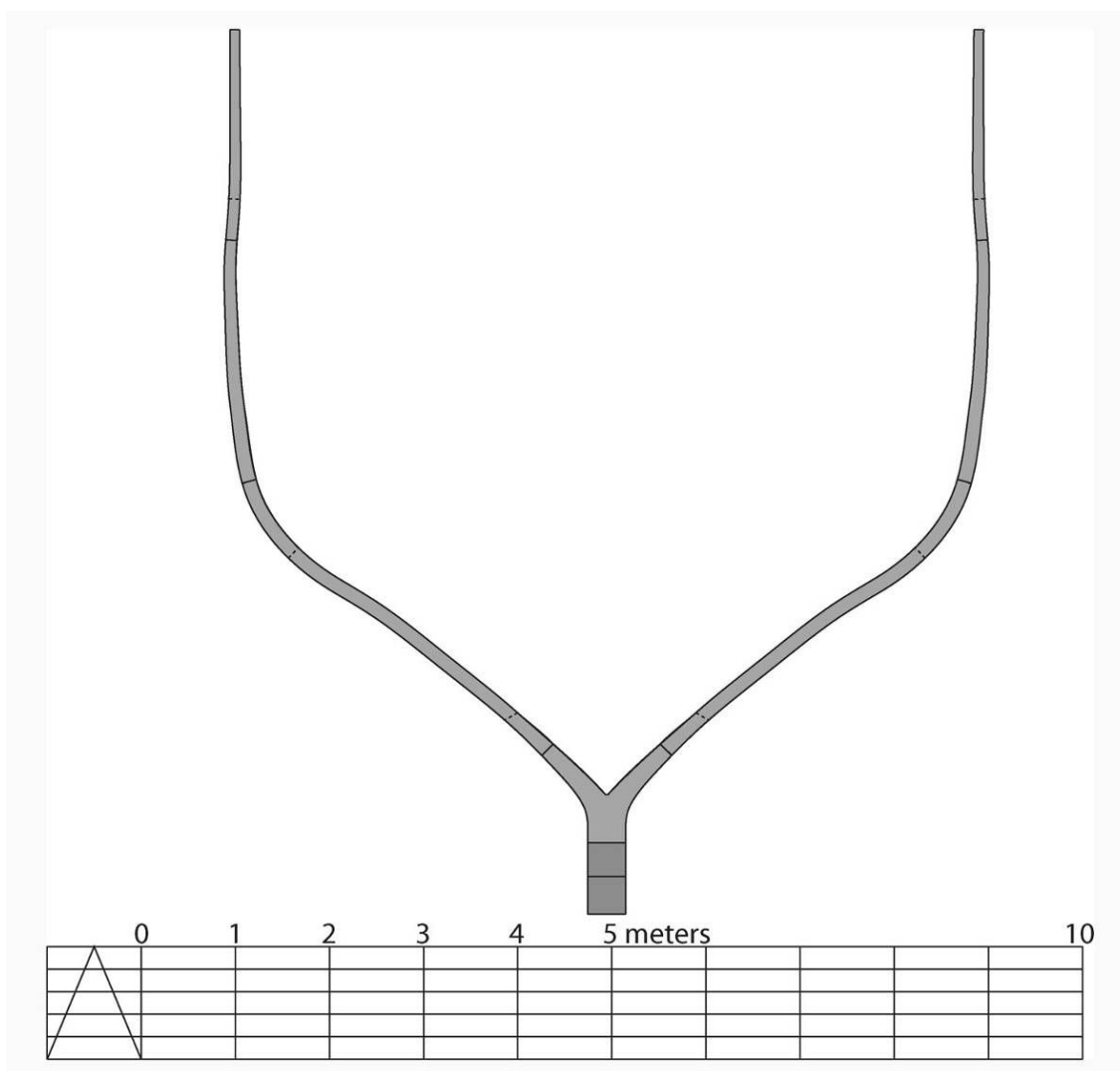

Fig. 94. Section of *Santo Antonio de Tanná*'s hull at the frame 39 aft.



Fig. 95. Three-dimensional view of frame 39 aft.

### Keelson

Most of the keelson survived and it was described in detail in the previous chapter.

### Stringers

*Santo Antonio de Tanná* had a total of 18 stringers that ran the entire length of the ship; 14 in the hold, and four in the main deck. Four more stringers existed in the stern castle for a total of 22 stringers. Starting from the bottom up, the first six stringers served as reinforcements at the turn of the bilge and the floor head line, three on each side. Two

other stringers were placed at mid hold, one on each side. From this point, the Portuguese distinguish between the above-mentioned lower stringers called *escoas do porão* and the upper stringers (*dormentes*). The first *dormentes*, was extremely important because, besides serving as longitudinal support, they served two other functions. The first was to support the hanging knees that were fitted atop the remaining stringers and the second function was to serve as shelf clamps for the *baileus*, an intermediary half deck in the hold made of planking in between the knees; for that reason the stringer was called the *dormente dos baileus* (Fig. 96).



Fig. 96. Photograph of the port side *dormente dos baileus* and hanging knees, facing aft. (Courtesy Robin Percy)

Another four stringers existed in the hold, two on each side of the vessel. The lower and upper pair (above the *dormentes dos baileus*) served as a support for the knees. A gap between these and the upper pair allowed for ventilation of the spaces between the frames. The upper pair served as the shelf clamps for the beams. Dimensions were given in the previous chapter.<sup>475</sup> In the main deck, four more stringers -- *dormentes do convés* -- probably existed, two on each side and they served the same function as the uppermost pairs of stringers in the hold (Fig. 97). Finally, it is likely that two additional pairs of stringers -- *dormentes of the tolda* --; were fitted into the upper works to support of the stern castle deck.

#### Deck beams and stanchions

At least ten of the lower deck's beams were supported by stanchions, as grooves cut into the top of the keelson attest. The stanchions recovered had a square section of 21 cm. However, the lower deck had many more beams to support the weight of the guns mounted upon it (not all deck beams were supported by stanchions). In the reconstruction thirty-one lower deck beams were fitted in the hold, one every three frames. Aft of the mast step the beams alternate between having a stanchion and lacking one. Forward of the main mast the number of beams without stanchions increased because of the increasing distances of the stanchion grooves. This different spacing could have indicated the area of the main hatch, which was likely located forward of the

---

<sup>475</sup> Chapter VIII, 138-9.

main mast, either between the second and third stanchion towards the bow (counting from the mast partner stanchion). Four half beams were added to the reconstruction to support the main hatch.

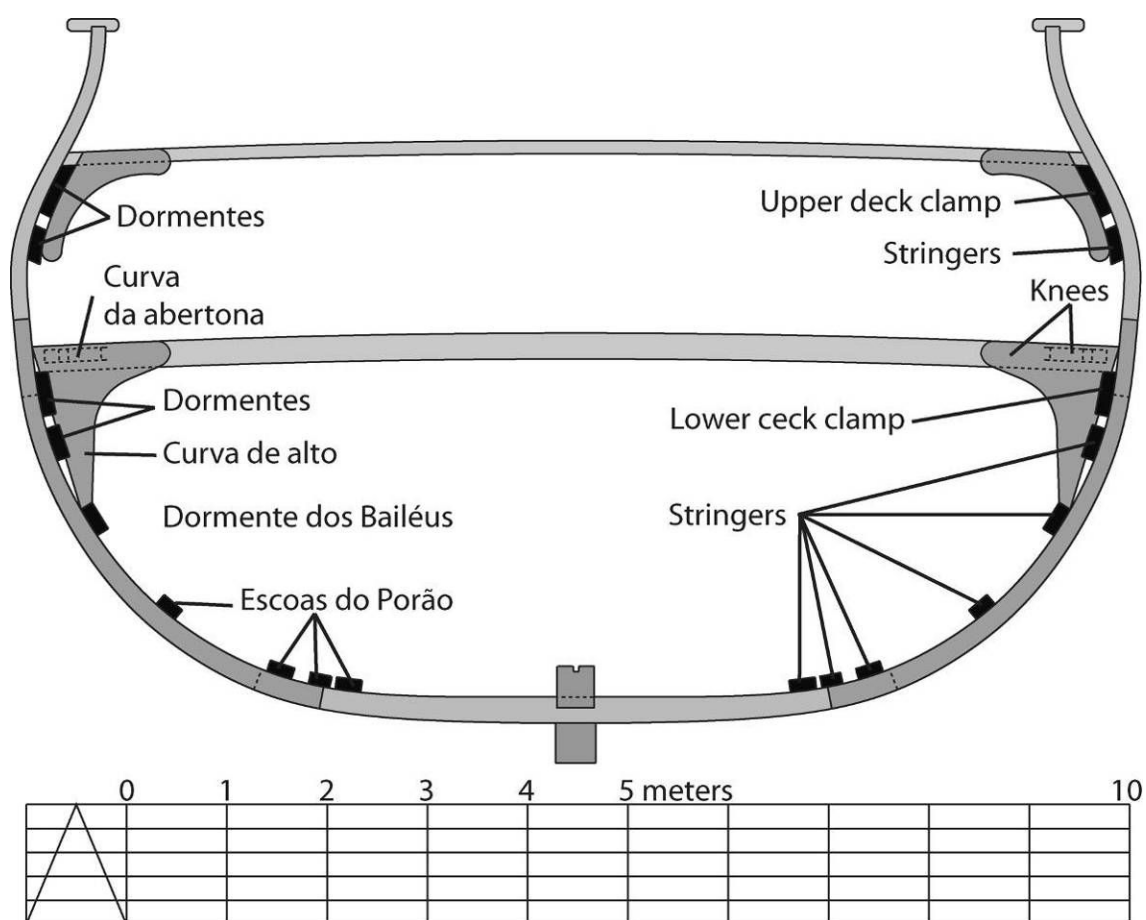

Fig. 97. Master-frame showing the stringers with their Portuguese names on the left.

Of the 31 lower deck beams, three served to support the mizzen mast and were placed under it; it is surprising that no grooves were found in the top of the keelson and these



deck beams are unsupported by stanchions. Four other deck beams out of the 31 also served as mast partners and have stanchions supporting them, increasing the number of stanchions from 10 to 12. The mast partners of the fore mast were located in the area that did not survive. In the reconstruction the weather deck beams were placed every three frames, resulting in 24 deck beams supporting the deck. The weather deck was given the same number of stanchions as the lower deck. Three pairs of deck beams served as mast partners for the three masts and one additional deck beam to support the bowsprit was added, totalling the number of weather deck beams to 31. The deck beam that supported the bowsprit was enlarged to twice the size of the others. As in the case of the main deck bellow, four weather deck half-beams were added to support the sides of the main hatch. Twelve deck beams supported the stern castle deck, making the total number of deck beams in this vessel 74 (Fig. 98).

Additional support was given to some of the beams by hanging knees, the *curvas de alto*. According to the archaeological record, knees seem to have been fitted to nearly every lower deck beam. They were placed along the side of each beam and together with *curvas da abertona*, or horizontal knees that were placed on the opposite side of beams locked the ends of the beams in place. Carlings probably existed in the centre area of the two principal decks; as these pieces, placed longitudinally, would have helped support the deck. No remains survived and their presence was inferred from iconography and written sources. The final locking piece was the *trincaiz*, or waterway fitted over the frames longitudinally from bow to stern, which rested on top of each deck beam that also

received the ends of the deck planking, helping to secure them in place. Except at bow and stern where it is the sides of the outermost deck planks that fit against the waterway.

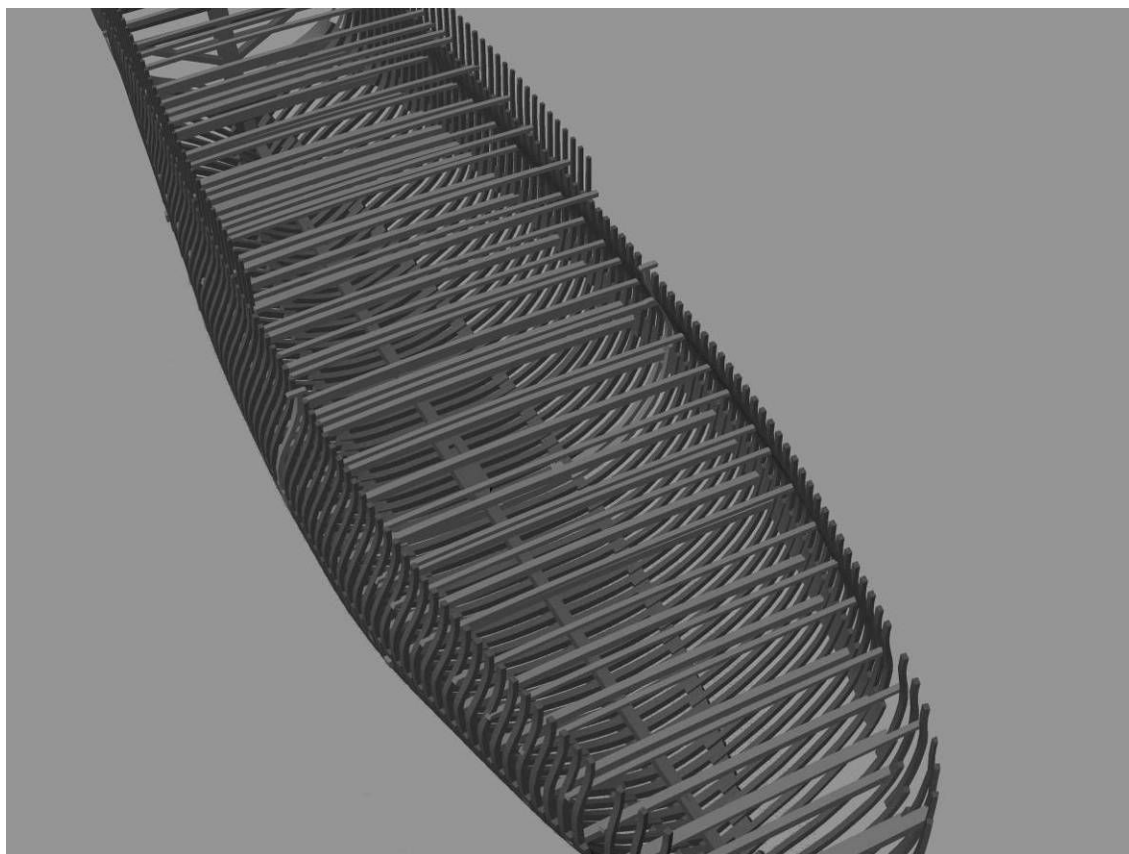

Fig. 98. View of *Santo Antonio de Tanná* showing the deck beams.

The position of the deck beams was calculated by the position of the stanchion groves and the surviving knees, from which the position of the other beams was estimated. However, due to the placement of hatches several beams had to be moved until a perfect fit was found. The shape of the deck beams had a specific feature, which was inferred

from the *Regimentos*: the very low arc or camber (*flecha*) of the deck beams. No archaeological information was available for the molded dimensions, so the dimensions of the deck beams were an estimate from the Keltridge drawings converted into Portuguese *palmos*. The beams dimensions decreased from the main to the weather deck, and still further for the quarter deck.

### Hatches

Several hatches existed for access into the hold, the most important of which were the main hatch for cargo and supplies, the ammunition hatch for sending gunpowder and cannon shot up to the main deck, the bosun's hatch for access to the bosun's locker in the bow, and two cable hatches located at the sides of the fore mast and near the bits for stowing and deploying the anchor cables (Fig. 99).

### Wales

No wales have survived, and the wales on the reconstruction were based on the dimensions of the stringers, with a square section of 22 cm. A great number of wales were placed in the model, almost one wale between each strake, because a great number of wales in the upper works was a characteristic observed in several Portuguese paintings of the early seventeenth century.<sup>476</sup> Regarding their assembly, the principal wales rested directly on the exterior faces of the frames and the upper wales were placed on the hull planking.

---

<sup>476</sup> Fernandez 1989.

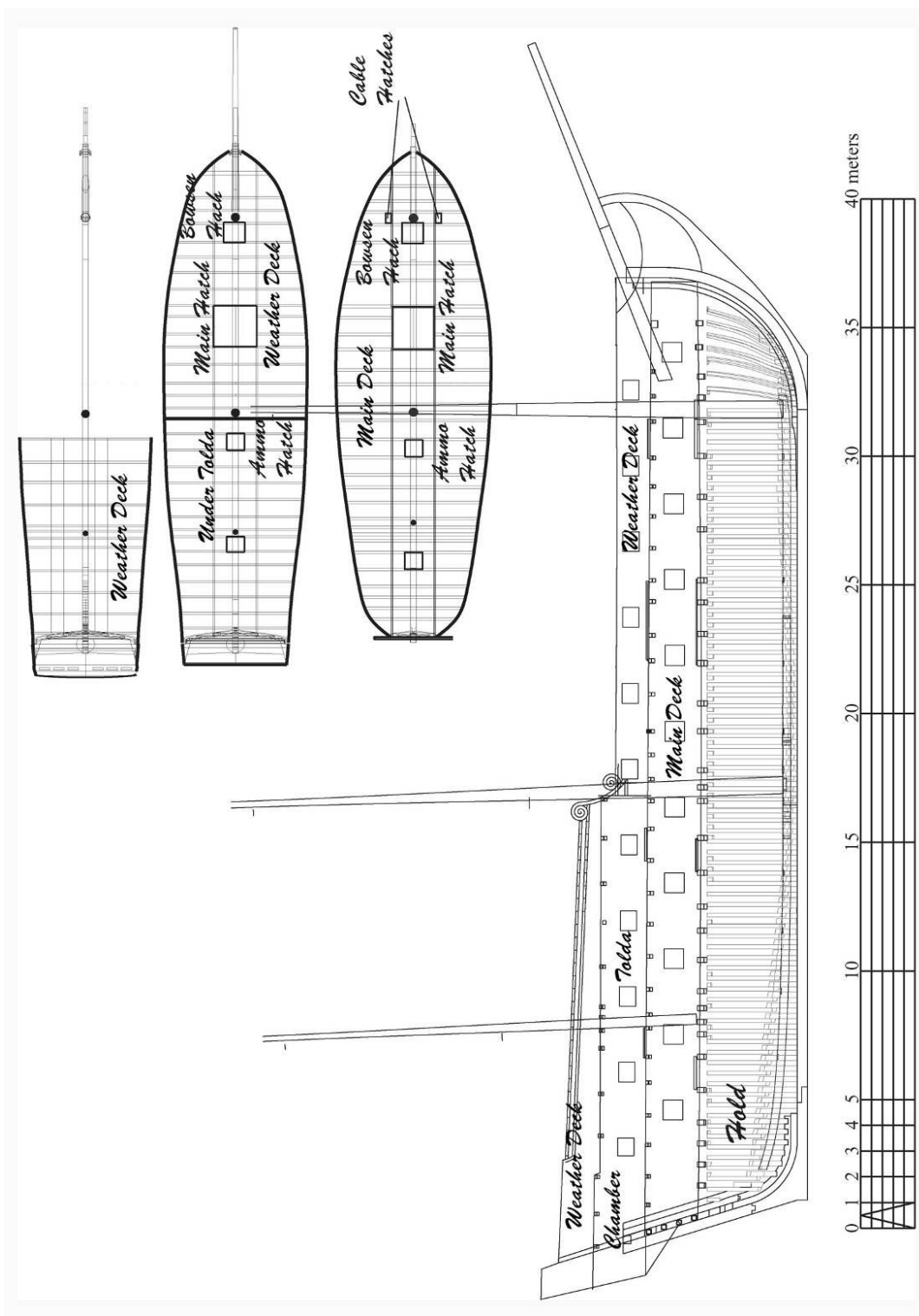

Fig. 99. Hatches position in Santo Antonio de Tanná.

### Waterway wale

The *tabuado do canto quebrado* was the strake placed in the weather deck at the same level as the deck planking where openings with hinged covers scuppers or *porta de mar*, were fitted. This system allowed any water running on the weather deck to be drained over the sides of the ship.

### Caprail

The caprail was composed of the *alcatrates da borda* which received both the outer and inner planking of the vessel. Placed on top of these pieces existed the *talabardão*, a thick piece that served as caprail. No information was ascertained about any fixtures for a hammocks rack on the caprail (which became common in the eighteenth century), so none were added.

The following pictures show the complete proposed master-frame with all the hull construction information discussed in this thesis (Fig. 100 and Fig. 101).

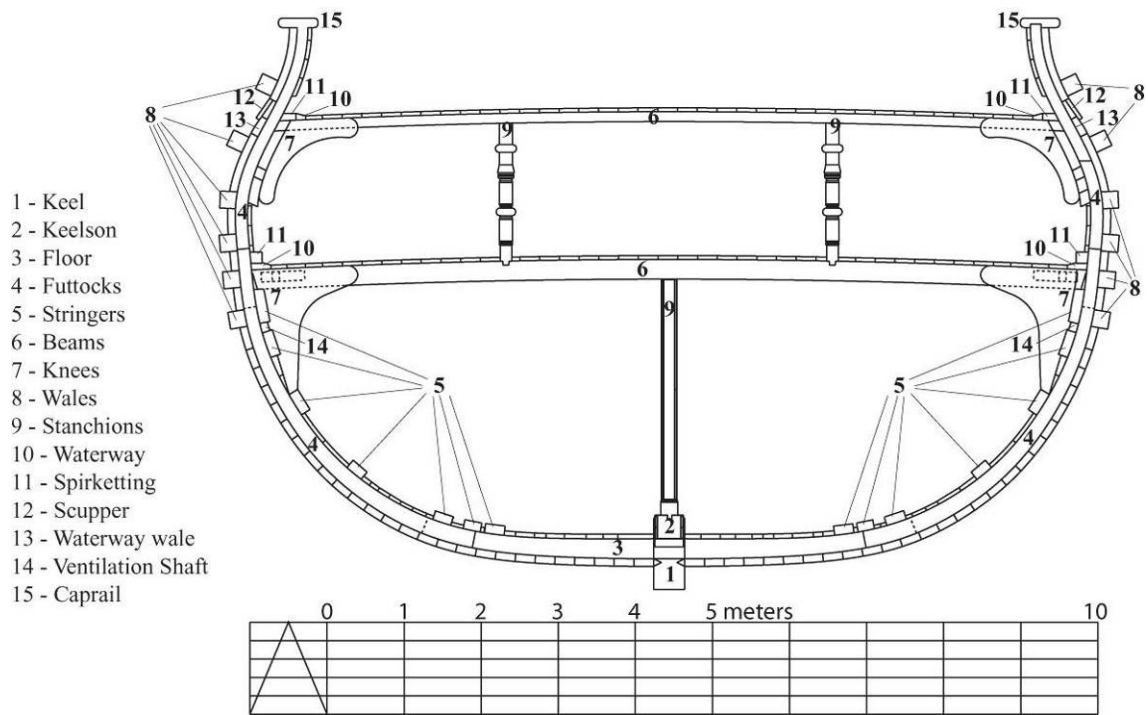

Fig. 100. The *Santo Antonio de Tanná* master-frame, showing hull elements.

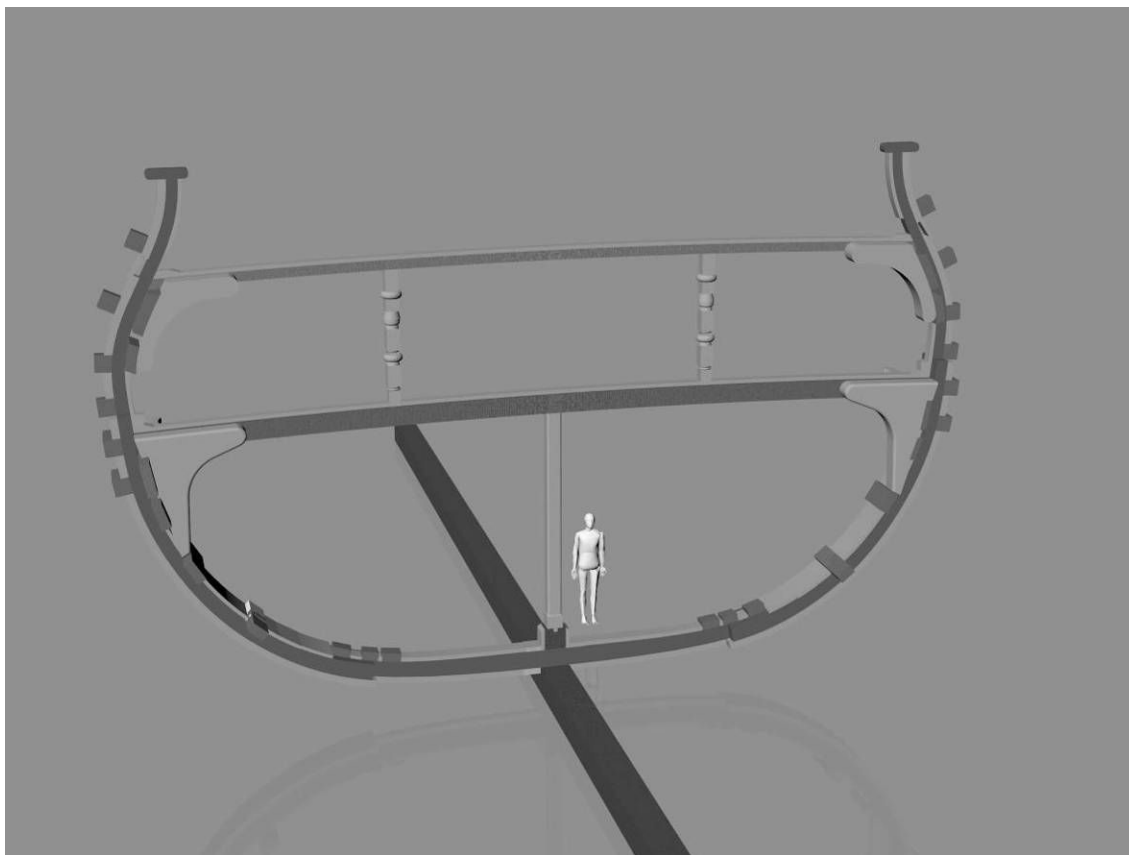

Fig. 101. *Santo Antonio de Tanná*'s master-frame three-dimensional view.

### Planking

The planking of the ship was more complex than originally realized and seventeenth century terminology distinguishes between several areas of the hull besides the division of outer and inner planking. According to the *Relação*, the hull is divided in nine areas which were all planked differently.<sup>477</sup> Table 5 presents the planking areas and Figure 102

---

<sup>477</sup> Lines 17, 20, 38, 40 - 1, 47, 61- 2 and 69 of the *Relação* (anonymous, c1690s)

shows a section of the ship with the planking information. Unfortunately, it was impossible to ascertain if planking differences were present in *Santo Antonio de Tanná*. There is no other seventeenth century Portuguese ship wreck in which the archaeological record could prove or disprove this information.

**Table 5. Planking areas of the ship based on the *Relação*.**

Portuguese	Translation
Forro do porão	The ceiling of the hold
Taboado da coberta e baileos do Porão	The planking of the orlop deck and the planking for the hold's shelves on the <i>dormente dos baileus</i>
Taboado da tolda	The stern castle deck planking
Taboado do Convés	Weather deck planking
Taboado do fundo	The planking of the area composed by the bow's cant frames.
Tabuado da alcaixa grande	Outer planking in between the wales
Forro das amoradas da Coberta de baixo	Orlop deck ceiling
Forro das amoradas do Conves e tolda	Planking of the weather deck sides and the sides of the stern castle
Forro do fundo até a cinta	Outer planking from the keel up to the first wale on the orlop deck



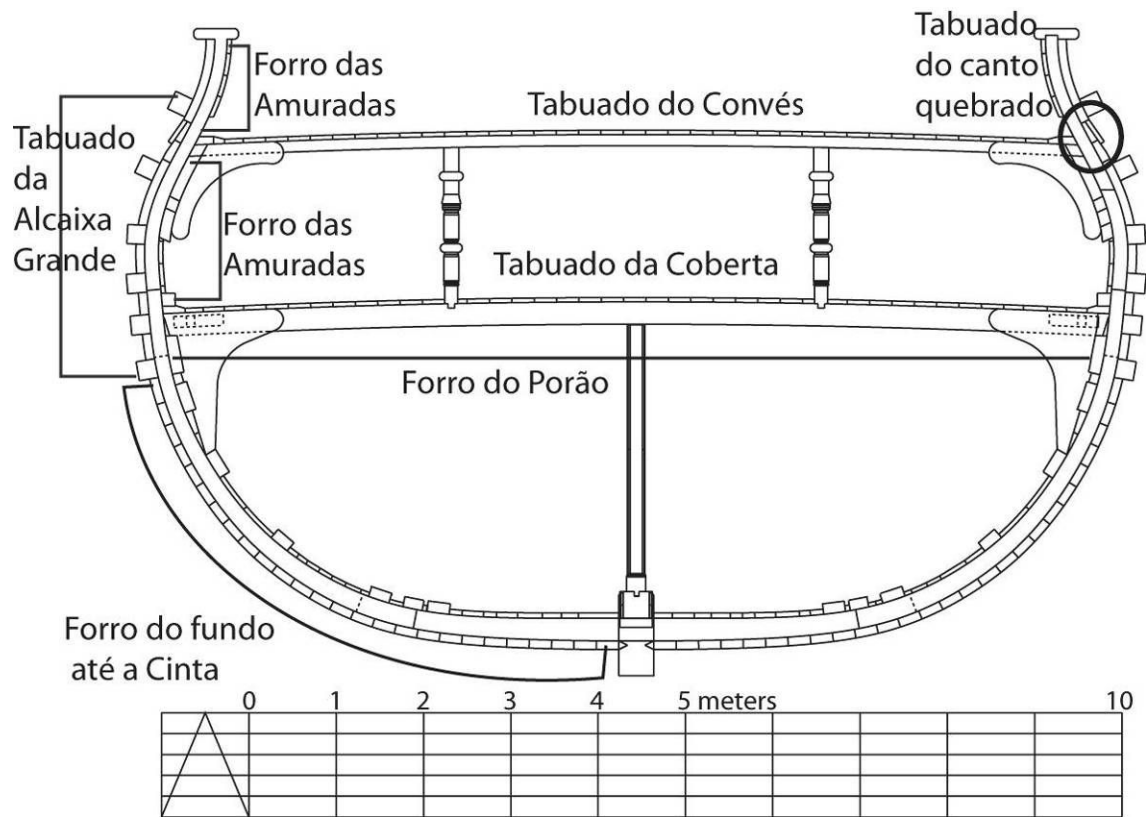

Fig. 102. The *Santo Antonio de Tanná* master frame showing planking areas.

In conclusion, this work used archaeologically – derived information (incomplete through it was, contemporary texts, and iconographic material) to go from the known remains of the vessel, seen in dark gray on the following figure (Fig. 103), to the proposed reconstruction presented in the next figures (Fig. 104 to 105).

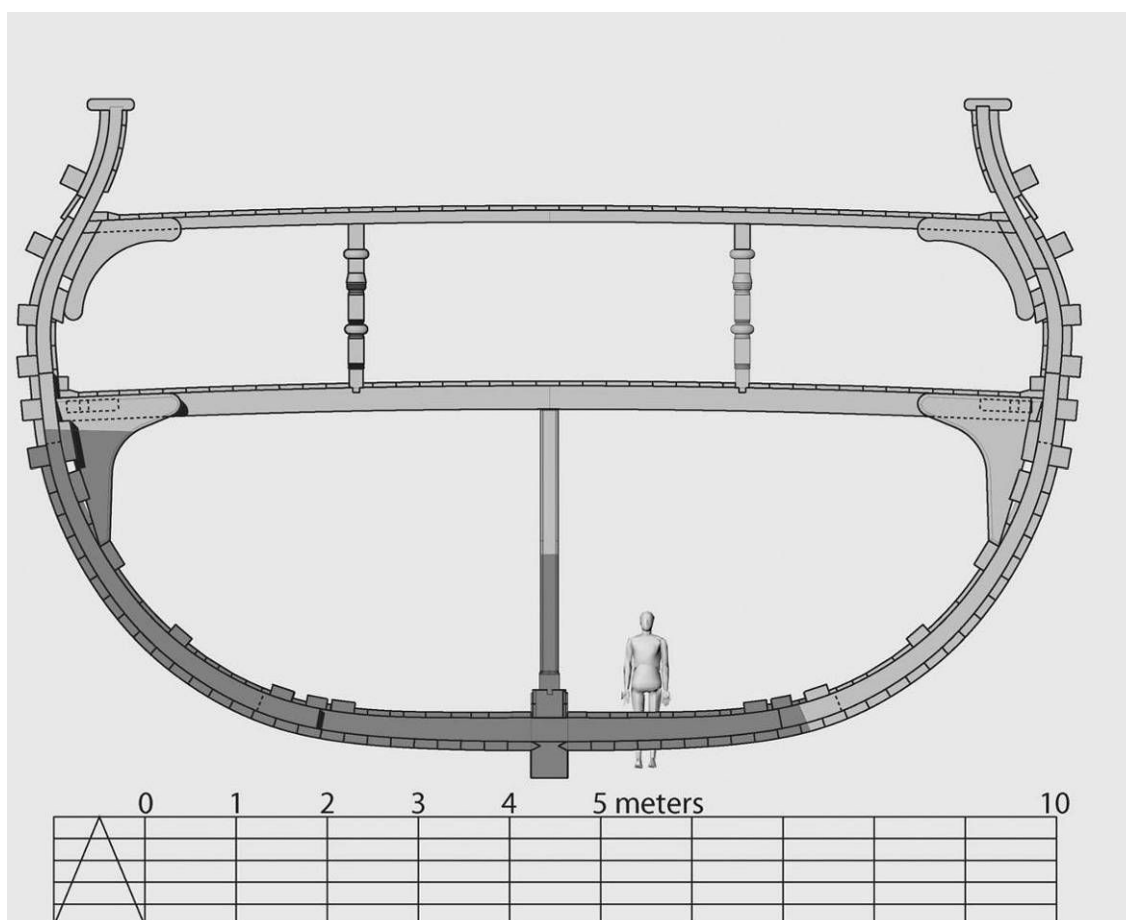

Fig. 103. Master frame, dark gray shows known remains, and light gray displays proposed solutions.

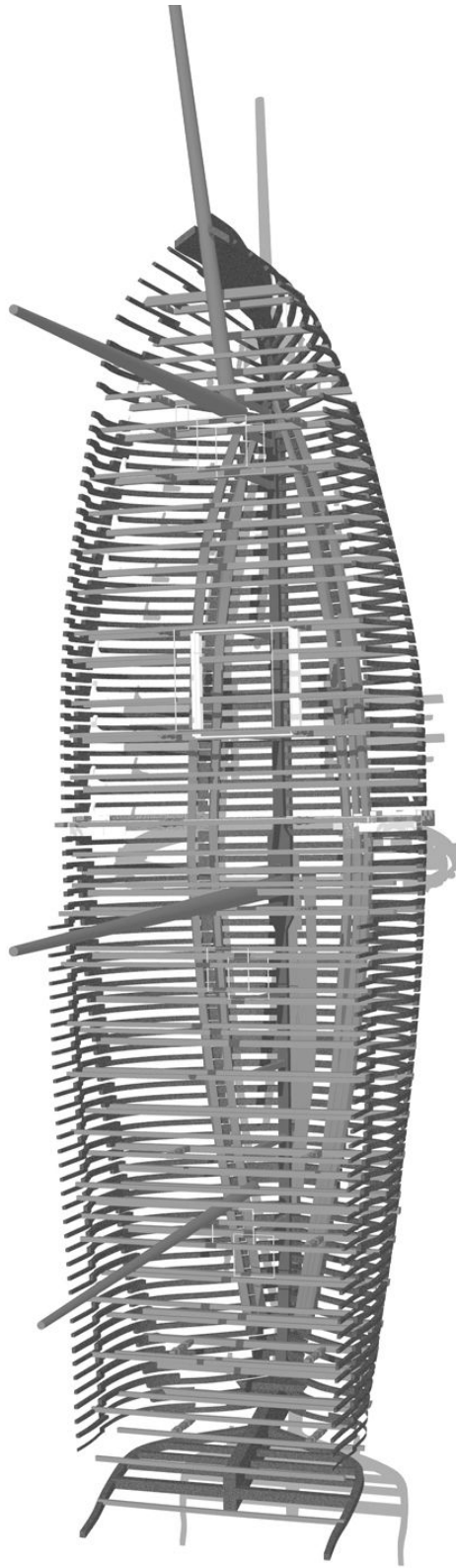

Fig. 104. Three-dimensional breadth view of the *Santo Antonio de Tanná*.

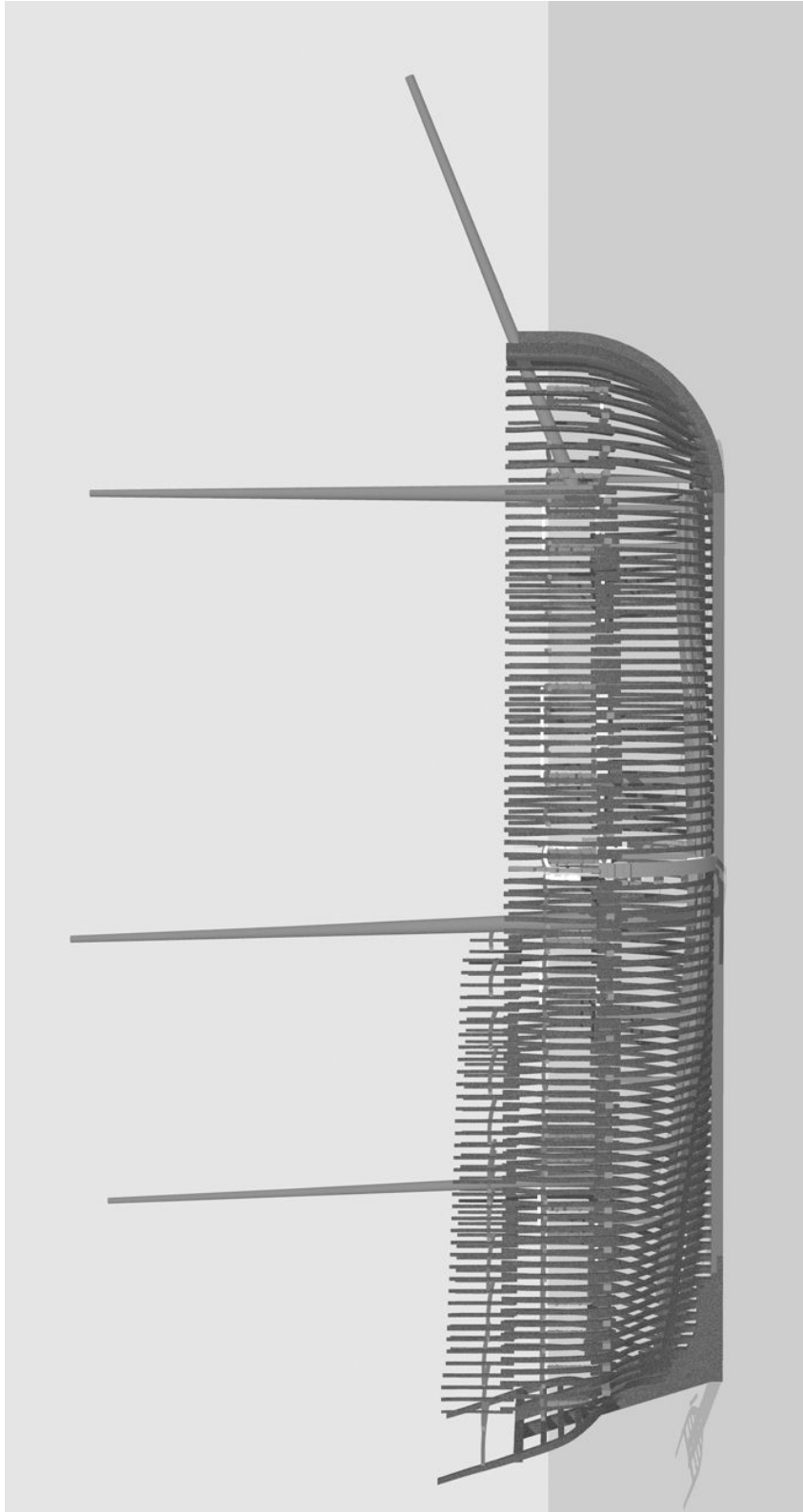

Fig. 105. Three-dimensional sheer view of the *Santo Antonio de Tanná*.

## CHAPTER X

### CONCLUSIONS

The history of Portuguese nautical adventure was summarized best in the words of Padre António Vieira (1608-1697): “God has given my people a small land for their birth, but the entire world in which to die.”

Portugal is a country with an area of 92,361 sq. km, smaller than the state of Indiana or, roughly, one seventh the size of the state of Texas. Yet, its population was able to launch a movement that led to the discovery and establishment of a prodigious trade network extending over 100,000,000 sq. km, an area roughly 10 times greater than the surface of the United States of America.

From the fifteenth century onwards, Portugal developed a number of technical solutions that allowed its sailors to overcome the barriers posed by crossing the Atlantic Ocean and by open sea voyages lasting more than six months. By the early seventeenth century, those technical solutions had allowed Portugal to develop one of the most advanced trade networks in the world. During the unification of the Iberian Crowns, Philip II of Spain (also known as Philip I of Portugal) was the sole ruler of the first global trade network in history. Never again was this position achieved by any other nation.

Understanding the technical solutions that led to the construction of sturdy, far - voyaging vessels, which caused social and economic changes with worldwide repercussions, is vital to understanding the world today.

However, when studying the European maritime expansion (e.g. the trading empires that followed the Portuguese voyages to the Far East, the Spanish conquest and occupation of Central and South America, and the settlement of the North American continent by the French and the English) there is almost no information available regarding the fifteenth and sixteenth century ships that made it possible. Most Portuguese and Spanish ships wrecks found in recent decades have been destroyed by looters and treasure hunters. Although historians have attained a fair understanding of the repercussions following the development of ocean - going three and four masted ships, the tools that allowed the reshaping of the known world (the ships themselves) are presently still mostly unknown. Part of that rich history was told in the previous chapters of this thesis, in the stories of *Santo Antonio de Tanná* and Fort *São Jesus*.

The reconstruction of *Santo Antonio de Tanná* presented in this thesis was a scientific speculation and sometimes an educated guess, a possible solution for the many questions we have regarding the ship's design and construction. However, if this study is presented as a conjectural reconstruction, it should be noted that it was based on extensive archaeological data and thorough archival research. Both the written and iconographic sources cited in the previous chapters made a strong case for the reconstruction decisions, the inferences, and the logical leaps required to develop this model of a seventeenth century Portuguese ship.

As most authors finishing their works come to know, were they to begin the same project anew armed with the knowledge they cultivated along the way, the results would be superior. The reconstruction of *Santo Antonio de Tanná* is no exception.

The model had a few shortcomings that will be immediately apparent to the expert's eye: the sheer on the profile of the hull is likely flatter than on the original vessel, there was a square look that permeates the entire reconstruction, and many curves looked like they were much smoother and fairer in the original.

However, as an attempt to understand a seventeenth century Portuguese frigate, the vessel presented here is a good basis and a solid start. This work ascertained the vessel's basic dimensions, described most of the structural components required to build this type of ship, located the position of the ship's master frame, and made sense when interpreted in light of the written and iconographic sources.

Ideally, a team could return to Mombasa and finish the excavation of the ship started by INA many years ago. This will probably not be possible, at least in a near future, given the complexities and logistics of such a project.

In the meantime, the questions remaining were impossible to answer with any kind of precision. But research is about asking questions and to answer them is called development. The model presented in this study must show the adaptations of the Portuguese trade networks to the late seventeenth century reality. But how? This was a century of loss for the Portuguese. Although the Portuguese presence in Asian waters

lasted until the twentieth century, after 1600 the Dutch Republic took over the power in the Indian and South Atlantic Oceans. Then in the late seventeenth century England took over the hegemonic position after three hard - fought wars with the Dutch. At a time in which other nations were also evolving and specializing their water craft, designing ships for specific roles, a look at *Santo Antonio de Tanná* suggested that Portugal may have maintained a design that would have served in the dual capacity of merchant and war vessel. *Santo Antonio de Tanná*, a cargo carrier with the ability to defend itself quite well, was in this sense a continuation of a culture that prevailed in previous centuries. A need for trade and defence in a world at war characterized both the Spanish and the Portuguese empires and was responsible for the policy of building ships that could at any given time play both roles.<sup>478</sup> Throughout the seventeenth century, eroding power and increasing competition from other nations resulted in a continuous loss of infrastructures overseas and made Portugal lose some of its privileged markets in the East Indies. How did this impact the country's shipbuilding industry? Far more comparative data will be needed to answer such a question.<sup>479</sup>

The scope of the present problem should not be lost. Besides the broader questions, a number of other issues remained unsolved. What were the exact dimensions of this ship? How was it decorated? Was there a meaning, a story to convey, as in other extant examples? Was this ship's construction influenced primarily by Spanish, French, or

---

<sup>478</sup> Rahn-Phillips 1992, 14, 40-1.

<sup>479</sup> However, the continuation of a cost-effective policy of developing vessels less specialized and able to serve in different capacities allowed the maintenance of the Portuguese trade network in the following centuries.



English fashions or ideas? Were there technical shortcuts taken to construct this vessel due to shortages of materials or difficulties experienced in the shipyard? What would be the cultural signatures of the Indian workers on *Santo Antonio de Tanná*? How were the cargo, supply arrangements, and accommodations of the crew made?

Those were only a small number of pertinent questions posed by this reconstruction, and it can be said that some of those answers lay under the sand and water of Mombasa harbour, waiting to be discovered. Even as these lines were written the urge to continue the work is persistent, but all things must end.

On a more positive note, the use of three-dimensional reconstruction tools allowed a new approach to this type of work; the necessity of assembling a coherent structure inherently compensated for the shortcomings of traditional line drawing methods. However, the challenge of three-dimensional reconstruction was a plus and a minus in itself. First, one must possess both computer programming and carpentry skills in order to reconstruct the ship's structure. More importantly, the three-dimensional mind-set must be nurtured and transformed into an analytical tool. However, the ability to rebuild the ship in three-dimensions has shown that some of the timbers represented in the seventeenth century drawings (e.g. Fernandez' drawings) were not entirely correct. It has also clarified the skills required to transform drawings and plans into reality. And above all it has made it clear that in order to understand these ships in detail, far more three dimensional reconstructions will be needed.

The making of this thesis required considerable work, induced a fair share of insomnia, and yielded considerable fun; but most importantly it has been the summation of the amazing skills of several individuals and not the creation of a single student. And this student intends to carry the research further because those persons deserve no less.

## WORKS CITED

- Abell, W. 1981. Reprint. *The Shipwright's Trade*. London: Conway Maritime Press.  
Original edition, London: Conway Maritime Press, 1948.
- Albuquerque, L. ed. 1989. *Portugal no Mundo*, Vol. 2. Lisboa: Publicações Alfa
- Albuquerque, L and F. C. Domingues. 1994. *Dicionário de História dos  
Descobrimentos Portugueses*. Vol. 2. Lisboa: Circulo de Leitores.
- Alves, F. ed. 2001. *Proceedings International Symposium on Archaeology of Medieval  
and Modern Ships of Iberian-Atlantic Tradition*. Lisboa: Instituto Português de  
Arqueologia.
- Ames, G.J. 1998. "An African Eldorado? The Portuguese Quest for Wealth and Power in  
Mozambique and the Rios de Cuama, c. 1661 – 1683." *International Journal of  
African Historical Studies*. 31(1):91-110.
- Anderson, R.C. 1928. "Comparative Naval Architecture, 1670-1720." *Mariner's Mirror*  
7(1): 38-45.
- Anderson, R.C. 1941. "The Ancestry of the Eighteenth-Century Frigate." *Mariner's  
Mirror* 27(2): 158-65.
- Anonymous, c1690s. Manuscript. "*Relação dos nomes das peças de construção e das  
madeiras do Brasil próprias para elas.*" Biblioteca Central de Marinha. RDD6076.
- Anonymous, 1988. Reprint. *Álbum de Colbert*. Nice: Omega. Original edition, Paris,  
1670.

- Archibald, E. H.H. 1989 *Dictionary of Sea Painters* 2nd. ed. Suffolk: Antique Collector's Club.
- Axelsson, E. 1960. *Portuguese in South-East Africa 1600-1700*. Johannesburg, South Africa: Witwatersrand University Press.
- Barbour, V. 1930. "Dutch and English Merchant Shipping in the Seventeenth Century." *Economic History Review* 2(2):261-90.
- Barker, R. 1994. "A Manuscript on Shipbuilding, Circa 1600, copied by Newton." *Mariner's Mirror* 80(1):16-29.
- Baumber, M. L. 1971. "The Navy and Civil War in Ireland 1641 -1643." *Mariner's Mirror* 57(4):385-97.
- Berg, F. J. 1968. "The Swahili Community of Mombasa, 1500-1900." *Journal of African History* 9(1):35-56.
- Blot, J-Y. and M. L. Blot. 1984. Unpublished. "Report on Research in India and Portugal on the Historical Aspects of the 17<sup>th</sup> Century Portuguese Frigate *Santo Antonio de Tanna* Sunk in Mombasa, Kenya, November, 1697." College Station: Institute of Nautical Archaeology.
- Bocarro, A 1992. Reprint. Vol. 2, *Livro das Plantas de todas as fortalezas cidades e povoações do estado da Índia Oriental*. Lisboa: Imprensa Nacional Casa da Moeda.
- Boudriot, J. 1990. *Historique de la Corvette, 1650 – 1850*. Paris: J. Boudriot.
- Boudriot, J. 1993. *The History of the French Frigate, 1650-1850*. Translated by D.H. Roberts. Sussex, UK: J. Boudriot.

- Boxer, C and C. Azevedo. 1960. *Fort Jesus and the Portuguese in Mombasa*. London: Calouste Gulbenkian Foundation.
- Boxer, C.R. 1984. *From Lisbon to Goa, 1500-1750*. London: Variorum Reprints.
- Boxer, C.R. 1992. *O Império Marítimo Português 1415-1825*. Translated by I.S. Duarte. Lisboa: Edições 70.
- Bushnell, E. 1669. *The Complete Shipwright*. London (Third edition). Texas A&M: Evans Library Microfilms. Film B 3609 1587:22
- Carrasco, A. and A. Peres. 1997. *Barcos no Tejo*. Lisbon: INAPA.
- Castro, F. 2001. "The Pepper Wreck: A Portuguese Indiamen at the Mouth of the Tagus River." Ph.D. diss., Texas A&M University.
- Castro, F. V. 2004, 29 October. *Ship Treatises and Books*.  
<http://nautarch.tamu.edu/shiplab/> (5 November 2004).
- Castro, F.V. 2005. *The Pepper Wreck: A Portuguese Indiamen at the Mouth of the Tagus River*. College Station: Texas A&M University Press.
- Catalogue. 1997. *Praise of Ships and the Sea*. Rotterdam, Netherlands: Museum Boijmans Van Beuningen.
- Chaudhuri, K. 1998. "A concorrência Holandesa e Inglesa." In *Historia da Expansão Portuguesa*. Vol. 2, *Do Índico ao Atlântico 1570-1697*, edited by F. Bethencourt and K Chaudhuri, 82-111. Lisboa: Circulo de Leitores e Autores.
- Chittick, N. 1969. "A New Look at the History of Pate." *Journal of African History* 10(3):375-91.

- Ciciliot, F. 2005. *La Superbe Navi: Cantieri e tipologie navali liguri medievali*. Savona: Società savonese di storia.
- Corvisier, A. 1977. *O Mundo Moderno*. Historia Universal. Translated by R.R. da Silva and C.O.C. Amaral. Lisboa: Circulo de Leitores.
- Crumlin-Pederson, O. 1991. "Ship Types and Sizes," *Aspects of Maritime Scandinavia, AD 200-1200*. Roskilde, Denmark: Roskilde Museum.
- Culver, H. B. 1954. *Contemporary Scale Models of Vessels of the Seventeenth Century*. New York: Book Collectors Society.
- Dassié, F. 1994. Facsimile. *l'Architecture navale*. Sanremo, Italy: Pharos. Original edition, Paris, 1695.
- Disney, A. R. 1981. *A decadência do império da Pimenta: Comércio Português na Índia no inicio do séc. XVII*. Translated by P. Jordão. Lisboa: Edições 70.
- Dudleo, R. 1646. Manuscript. *Livro dell' Arcano Del Mare*. Vol.3/4. Ferenze, Italy: Francesco Onofri.
- Duro, F. 1996. *Disquisiciones náuticas*. Madrid: Ministerio de Defensa, Secretaría General Técnica: Instituto de Historia y Cultura Naval.
- Esparteiro, A. M. 1987. *Três Séculos no Mar 1640-1910*. III Parte/Fragatas/1.º Volume. 10. Lisboa: Instituto Hidrográfico.
- Fennis, J. 1983. *Un manuel de construction des galères, Edition annoté des manuscrits SH 132 a 134 (1691) du Service Historique de la Marine à Vincennes*. Amsterdam: Maarssen.

- Fernandez, M. 1989. Facsimile. *Livro de Traças de Carpintaria*. Lisboa: Academia de Marinha. Original edition, Lisboa, 1616.
- Fernandez, M. 1995. Reprint. *Livro de Traças de Carpintaria*. Translated by M. Leitão. Lisboa: Academia de Marinha. Original edition, Lisbon, 1616.
- Filgueiras, O. L. ed.1988. *Local Boats: Fourth International Symposium on Boat and Ship Archaeology, Porto 1985*. Oxford, UK: BAR International Series.
- Franklin, J. 1989. *Navy Board Ship Models 1650-1750*. London: Conway Maritime Press.
- Gardiner, R. 1992. *The First Frigates*. London: Conway Maritime Press.
- Gaztañeta Iturribalzaga, J. A. 1992. *Arte de fabricar Reales*, Barcelona: Lunweg.
- Goedde, L. O. 1989. *Tempest and Shipwreck in Dutch and Flemish Art*. London: Pennsylvania State University Press.
- Goncharov, I.A.1987. *The Frigate Pallada*. New York: St. Martins Press.
- González F.F., C.A. Cardenal and F.M. Garcia. 1992. *Arte de Fabricar Reales: Edición comentada del Manuscrito original de Don Antonio de Gaztañeta Yturribalzaga. 2*. Vols. Barcelona: Lunweg.
- Green, J. 1991. "Hull Recording Methods Used at Mombasa." *INA Newsletter* 18(2): 8-9.
- Howkins, T. 1689. *Gloria Britannica*. London: Thomas Howkins. Early English Books Online.
- Howkins, T. 1696. *Gloria Britannica*. London: Samuel Clark. Early English Books Online.
- Jordan, B. 2001. "Wrecked Ships and Ruined Empires: an Interpretation of the *Santo Antonio de Tanna's* Hull Remains Using Archaeological and Historical Data." In

- Proceedings International Symposium on Archaeological of Medieval and Modern Ships of Iberian-Atlantic Tradition*, edited by F. Alves, 301-16. Lisboa: Instituto Português de Arqueologia.
- Jouve, J. 1971. Reprint. *Deux Albums des Batiments de L'Atlantique et de la Méditerranée*. Nice, France: Omega. Original edition, Paris, 1679.
- Kemp, P.K. 1976. *The Oxford Companion to Ships and the Sea*. London: Oxford University Press.
- Kepler, J. S. 1973. "The Value of Ships Gained and Lost by the English Shipping Industry during the Wars with Spain and France, 1624-1630." *Mariner's Mirror* 59(2):218-21.
- Kirkman, J. 1975. *Fort Jesus: Mombasa*. 8<sup>th</sup> ed. Mombasa: Museum Trustees of Kenya.
- Kirkman, J. 1983. "The Muzungulos of Mombasa." *International Journal of African Historical Studies* 16(1):73-82.
- Kochiss, J. M. 1978. "Tagus River Barges and Passenger Carriers." *Mariner's Mirror* 64(2):169-85.
- Lafon, F. 1695. *Construction des Vaisseaux du Roi, et le nom de toutes les pieces qui y entrent, marquées la Table par numero*. Rocheford, France: Marchant Librairie.
- Lavanha, J. B. 1996. Facsimile. *Livro Primeiro da Architectura Naval*. Lisboa: Academia de Marinha. Original edition, Lisboa, 1610.
- Lavery, B. 1981. *Deane's Doctrine of Naval Architecture 1670*. London: Conway Maritime Press.



- Lavery, B. 1983. *The Ship of the Line*. Vol. 1, *The Development of The Battlefleet 1650-1850*. London: Conway Press.
- Lavery, B. 1984. *The Ship of the Line*. Vol. 2, *Design, Construction and Fittings*. London: Conway Press.
- Leitão, H., and V. Lopes. 1990. *Dicionário da Linguagem de Marinha Antiga e Actual*. 3d Ed. Lisboa: Edições Culturais da Marinha.
- Leitão, M. 1978. *Boats of the Lisbon River: Fragatas and Related Types*. Maritime Monographs and Reports 34. London: Conway Maritime Press.
- Lima, D. P. De. 1946. *O Oriente e a África desde a restauração a Pombal*. Lisboa: Agencia Geral das Colônias.
- Linage, J. V. 1688. Manuscript. *Norte de la Contratacion de las Indias Occidentales*. Sevilla: Juan Francisco de Blas.
- Lofgreen, L. 1984. *Ocean Birds*. New York: Knopf.
- Madahil, A.G. R. 1934. "Um desconhecido tratado de arte naval portuguesa do século XVII." *Arquivo Histórico da Marinha* I(3):277-93.
- Magalhães, J. 1998. "A construção do espaço Brasileiro." In *Historia da Expansão Portuguesa*. Vol. 2, *Do Índico ao Atlântico 1570-1697*, edited by F. Bethencourt and K Chaudhuri, 82-111. Lisboa: Circulo de Leitores e Autores.
- Marshal, P. J. 2001. "The English in Asia." In *Oxford History of the British Empire*. Vol. 1, *The Origins of Empire*, edited by N. Canny, 241-85. London: Oxford University Press.

- Mauro, F. 1988. *Portugal Brasil e o Atlântico:1570-1670*. Vol. 2. Translated by Manuela Barreto. Lisboa: Editorial Estampa.
- Melo, A.C [n.d.] Manuscript. *Planta da ilha de Mombaça, e descrição do princípio do seu [verco] até o fim dele para ver o senhor conde de Avinte ou meu irmão o senhor conde da Galveas que mando por curiosidade para [sescer] o conto se perdeu esta praça*. Fundação Biblioteca Nacional: Coleção Marque. Ref. I-32,34,013 n°006.
- Merino, J. and J. Meyer. 1986. “Les Marines de Guerre Europennes XVII-XVIIIe Siècles.” In *Ships and Shipping in the North Sea and Atlantic, 1400-1800*, edited by R. W.Unger, 1997, **XV**:21-34. Aldershot, UK: Ashgate.
- Meyer, R.W. 1981. “English Privateering in the War of 1688 to 1697.” *Mariner’s Mirror* 67(3):259-72.
- Monteiro, A. S.S. 1996. *Batalhas e Combates da Marinha Portuguesa*, Vol VII. Lisboa: Sa da Costa editora.
- Monteiro, A.S.S. 1993. *A Evolução do Pensamento Naval Português*. Lisboa: Academia de Marinha.
- National Maritime Museum 2004, 1 November. *Ship Plans*.  
<http://www.nmm.ac.uk/site/request/setTemplate:singlecontent/contentTypeA/conWebDoc/contentId/238/navId/005002000> (4 November 2004).
- Oertling, T. J. 1989. “The Few Remaining Clues” in *Underwater Archaeology Proceedings for the Society of Historical Archaeology Conference*, edited by B. J. Arnold, 100-103. Baltimore: SHA.

- Oertling, T. 2001. "The Concept of the Atlantic Vessel." In *Proceedings International Symposium on Archaeological of Medieval and Modern Ships of Iberian-Atlantic Tradition*, edited by F. Alves, 232-40. Lisboa: Instituto Português de Arqueologia.
- Oertling, T. J. 2005. Characteristics of Fifteenth- and Sixteenth-Century Iberian Ships. In *The Philosophy of Shipbuilding*, edited by F. M. Hocker and C. A. Ward, 129-36. College Station: Texas A&M University Press.
- Ohlmeyer, J. H. 1990. "Irish Privateers during the Civil War 1642 – 50." *Mariner's Mirror* 76(2):119-34.
- Oliveira, F. 1981. Facsimile. *O Livro da Fábrica das Naus*. Lisboa: Academia de Marinha. Original edition, Lisboa, 1580.
- Oppenheim, M. 1894. "The Royal Navy under Charles I." *English Historical Review* 9(33):92-116.
- Piercy, R. 1977. "Mombassa Wreck Excavation. Preliminary Report 1977." *IJNA* 6(4):331-47.
- Piercy, R. 1978. "Mombassa Wreck Excavation. Second Preliminary Report, 1978." *IJNA* 7(4):301-19.
- Piercy, R. 1979. "Mombassa Wreck Excavation. Third Preliminary Report, 1979." *IJNA* 8(4):303-9.
- Piercy, R. 1980. "Mombassa Wreck Excavation. Fourth Preliminary Report, 1980." *IJNA* 10.2:109-18.
- Piercy, R. 1998. "A Escavação do Santo António de Tanna, um navio português naufragado no porto de Mombaça." *Al-madan* IIª série.7:135-40.

- Pinto, R. M. C. 2002. *A Costa Oriental Africana 1640-1668*. Lisboa: Estar.
- Pioffre, G. 1994. *L' Aurore, Frégate légère de 22 canons. 1697-1720*. Bourg en Bresse, France: Marines.
- Pona, A. 1890. "Contrucções Navaes no Seculo XVII." *Annaes do Clube Militar Naval*. XX:217-23,255-8.
- Pontillo, J.J. 1975. "Nautical Terms in Sixteenth Century American Spanish" Ph.D. diss., New York State University.
- Preston, R. 1974. *The Seventeenth Century Marine Painters of the Netherlands*. Leigh-on-Sea, UK: F. Lewis.
- Rahn Philips, C. 1992. *Six Galleons for the King of Spain: Imperial Defense in the Early Seventeenth Century*. London: John Hopkins University Press.
- Rahn Philips, C. 2000. "Manuel Fernandez and his 1616 'Livro de Tracas de Carpintaria'" *American Neptune* 60.1:7-29.
- Rieth, E. 1998 "Construction navale à Franc-Bord en Méditerranée et Atlantique (XIVe-XVIIe siècle) et 'Signatures Architecturales' Une Première Approche Archéologique." In *Méditerranée Antique. Pêche, navigation, commerce*, edited by E. Rieth. Paris: CTHS.
- Salisbury, W. and R.C. Anderson.1958. "A Treatise on Shipbuilding and a Treatise on Rigging Written About 1620 -1625." *Society for Nautical Research* 6:1-64.
- Sasson, H. 1982. "The Sinking of the *Santo Antonio de Tanna* in Mombasa Harbour." *Paideuma* 28:101-8.

- Sassoon, H. 1978. Unpublished. "Mombasa Wreck Excavation, Second Interim Report."  
Bodrum, Turkey: Institute of Nautical Archaeology.
- Sassoon, H. 1979. Unpublished. "Mombasa Wreck Excavation, Third Interim Report."  
Bodrum, Turkey: Institute of Nautical Archaeology.
- Sassoon, H. 1980. Unpublished. "Mombasa Wreck Excavation, Fourth Interim Report."  
Bodrum, Turkey: Institute of Nautical Archaeology.
- Sassoon, H. 1981. "Ceramics from the Wreck of a Portuguese Ship at Mombasa."  
*Azania* 16:98-130.
- Serrano Mangas, F. 1985. *Los galeones de la Carrera de Indias, 1650-1700*, Sevilla:  
Ed. Escuela de Estudios Hispano-Americanos de Sevilla.
- Serrano Mangas, F. 1992. *Función y evolución del galeón en la carrera de Indias*,  
Madrid: MAPFRE.
- Serrão, J.V. 1993. "O quadro económico: Configurações estruturais e tendências de  
evolução" In *Historia de Portugal*. Vol. 4, *O Antigo Regime*, edited by J. Matoso,  
71-117. Lisboa: Estampa.
- Stradling, R.A. 1992. *The Armada of Flanders: Spain Maritime Policy 1568-1662*.  
Cambridge: Cambridge University Press.
- Subrahmanyam, S. 1993. *O Império Asiático Português, 1500-1700: Uma História  
Política e Económica*. Linda-a-Velha, Portugal: Difel 82.
- Thompson, B.F.C. 1988. "The Rigging of a 17th-Century Frigate at Mombasa, Kenya."  
M.A. thesis, Texas A&M University.
- Thomson, A.L. 1964. *A New Dictionary of Birds*. New York: Nelson.

- Timeweel, H. C. 1979. "Guernsey Privateers." *Mariners Mirror* 56(2):199-218.
- Tunstall, B. 1990. *Naval Warfare in the Age of Sail: The Evolution of Fighting Tactics 1650-1815*. London: Conway Maritime Press.
- Vergé-Franceschi M. and E. Rieth 2001. *La France Meritime au temps de Louis XIV*. Paris: Editions du Layeur.
- Vicente Maroto, M.I. 1998. *Diálogo entre un Vizcayno Y un Montañés Sobre la Fábrica de Navíos : Estudio y transcripción del texto*. Salamanca, Spain: Universidad de Salamanca.
- Winfield, R. 1997. *The 50-Guns Ship*. London: Chatham Publishing.
- Woodman, R. 1997. *The History of the Ship*. London: Conway Maritime Press.

## VITA

Tiago Miguel Fraga

Address: Dep. of Anthropology c/o Dr. Luis Vieira de Castro Texas A&M Univ. College Station Texas 77843 - 4352.

**Education:**

- 2007 Master of Arts in Anthropology, Nautical Archaeology Program at Texas A&M University (with scholarships from Calouste Gulbenkian Foundation and Luso-American Foundation for Development)
- 1999 Licenciatura, History, Universidade Lusíada de Lisboa

**Professional experience:**

- 2006 Nautical Archaeologist and Project Director, Câmara Municipal de Lagos.
- 2005 Lecturer of Nautical and Underwater Archaeology, Hipocausto
- 2004 - 3 Texas A&M University Graduate Assistant Non Teaching, Nautical Archaeology Program, Anthropology Department. Supervisor Dr. Donny Hamilton
- 2003 Chief Archaeologist, Project Underwater Cultural Heritage Survey & Excavation Faro A 2003. Project Director Dr. Jean-Yves Blot.
- 2002 - 1 Web Designer, Instituto Português de Arqueologia.
- 2001 Arqueotanda Lda (Manager, Senior Archaeologist).
- 2000 - 1997 Senior Archaeologist, Centro Nacional de Arqueologia Náutica e Subaquática – Instituto Português de Arqueologia.
- 1997 - 6 Junior Archaeologist, Centro de Operações de Arqueologia Subaquática da Expo'98 – Instituto Português do Patrimônio Arquitetónico e Arqueológico.