

DESICCANT COOLING SYSTEMS - A REVIEW

C. F. Kettleborough, M. R. Ullah, D. G. Waugaman
 Mechanical Engineering Department
 Texas A&M University
 College Station, Texas

ABSTRACT

Desiccant cooling systems have been investigated extensively during the past decade as alternatives to electrically driven vapor compression systems because regeneration temperatures of the desiccant - about 160°F, can be achieved using natural gas or by solar systems. Comfort is achieved by reducing the moisture content of air by a solid or liquid desiccant and then reducing the temperature in an evaporative cooler (direct or indirect). Another system is one where the dehumidifier removes enough moisture to meet the latent portion of the load while the sensible portion is met by a vapor compression cooling system; desiccant regeneration is achieved by using the heat rejected from the condenser together with other thermal sources. At present, residential desiccant cooling systems are in actual operation but are more costly than vapor compression systems, resulting in relatively long payback periods. Component efficiencies need to be improved, particularly the efficiency of the dehumidifier.

Desiccant cooling systems can be used with solar energy and can aid conservation of non-renewable energy resources.

Desiccants have been used for many years to provide dry air for a variety of industrial and commercial processes, in particular, for situations where very low humidities are required. Desiccant dehumidification for use in air conditioning systems is an extension of this. Both residential and commercial applications have been considered.

Residential applications have received most of the attention to date. The proposed systems typically dry air in a desiccant dehumidifier, cool the air through heat exchange with an available temperature sink, and then cool the air further in an evaporative cooler. These systems use either a solid or liquid desiccant, which is regenerated with solar or other thermal energy sources.

Recently, desiccant dehumidification has been considered for use in commercial air conditioning applications. In most of these systems, the dehumidifier removes only enough moisture to meet the latent portion of the cooling load, while the sensible portion is met by a vapor compression cooling system. The desiccant can be regenerated with the heat rejected from the condenser of the vapor compression system in combination with solar

Summer comfort conditioning consists of two functions: (a) decreasing the humidity and (b) decreasing the ambient temperature. Control of these can be achieved by one of several means: vapor compression systems, absorption systems, freon jet systems, etc. Direct evaporative coolers - known as swamp coolers - add moisture; indirect evaporative coolers cool at constant humidity ratio which causes an increase in the relative humidity. However, evaporative coolers do not have the capability of reducing moisture content. In humid areas, vapor compression has taken over as the standard form of cooling. A much simpler system is one where the moisture is removed by a desiccant and the temperature is reduced in an evaporative cooler. The system is essentially at or near atmospheric pressure.

Desiccant cooling systems have been investigated extensively during the past few years as alternatives to electrically driven vapor compression cooling systems. The natural gas industry is looking for new markets because of growing supplies and an interest in generating summer loads to balance their annual distribution profiles. The electric utilities are interested in reducing their peak summer loads caused by people using vapor compression air conditioning.

to use the strengths of the individual components to maximize system performance. Again, either solid or liquid desiccants can be used.

At the Solar Energy Research Institute (SERI), located in Denver, Colorado, the concept of desiccant cooling has been proven, advances have been made in component and system design and performance, and further improvements are expected. However, the current state-of-the-art desiccant system performance is not yet competitive with conventional systems in general practice. Additional work is needed to obtain further improvements and to implement them in actual components and systems.

SOLID DESICCANT SYSTEMS

Solid desiccant cooling systems have been investigated extensively at the component and system levels both analytically and experimentally. Several system configurations have been proposed. Two open-cycle systems that use adiabatic dehumidifiers have received much of the attention to date.

Most of this review summary is taken from references 1 through 3.

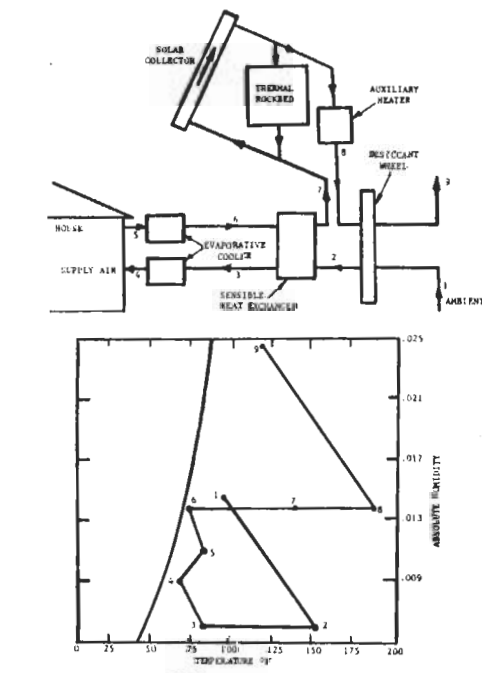

Fig. 1 Ventilation Cycle

These are the ventilation cycle, also known as the Pennington cycle, shown in Figure 1, and the recirculation cycle, Figure 2. In the ventilation cycle, as ambient air (1) is dried in the dehumidifier (2) its temperature increases because of the energy that is released in the adsorption process. Typically, this energy is slightly greater than the heat of vaporization. The process air is sensibly cooled (3) in the heat exchanger and then evaporatively cooled (4) to provide the conditioned air for the room (5). Room air is evaporatively cooled (6) to provide a sink for the heat exchanger. This air stream is then passed through the heat exchanger (7) where the energy released during adsorption is reclaimed. Additional heating (8) is done with solar or other thermal energy and the air stream is used to regenerate the desiccant (9). The recirculation cycle is similar except that room air is processed and recirculated, and ambient air is used for the regeneration stream. At ARI conditions (80°F and 50% relative humidity indoors and 95°F and 40% relative humidity outdoors), one might expect a COP near 1.2 for very high efficiency components [4]. The Pennington cycle modeled by Jurinak, Mitchell and Beckman [5] for a Ft. Worth cooling season predicted a maximum seasonal COP of 1.015. Grolmes and Epstein [6] have projected a Pennington cycle COP of 1.4 by impregnating the desiccant with inert materials.

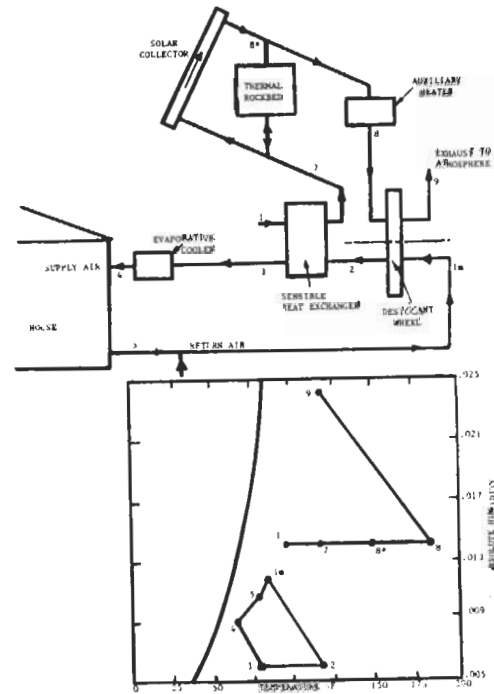

Fig. 2 Recirculation Cycle

These projections are at ARI conditions but are approximations based on their algebraic analysis. Exxon produced a one-ton test unit based on the Pennington cycle and achieved a COP of 1.1 [7]. In an adiabatic dehumidifier the temperatures can become fairly high because of the heat released during the adsorption process. This either limits the amount of dehumidification that can be done or increases the required regeneration temperature. By cooling the dehumidification process, either increased dehumidification (and therefore cooling capacity), or reduced regeneration temperatures (and therefore better solar system performance), can be expected.

An early modification to the Pennington cycle is the recirculation cycle shown in Figure 2. Unfortunately, this recirculation method does not improve the COP.* A COP of 0.8 would be high according to Jurinak [5]. Majundar, Worek, and Lavan [8] have modeled this arrangement but used cross-cooled desiccant wheels and predict a COP of 0.7.

In 1985, Maclaine-Cross [9] proposed a cycle with a COP in excess of 2.0. This cycle is known as the "SENS" cycle for the extra sensible heat

*COP = Coefficient of Performance and defined by

$$\frac{\dot{Q} \text{ (Cooling load)}}{\dot{Q} \text{ (Actual regeneration energy)}}$$

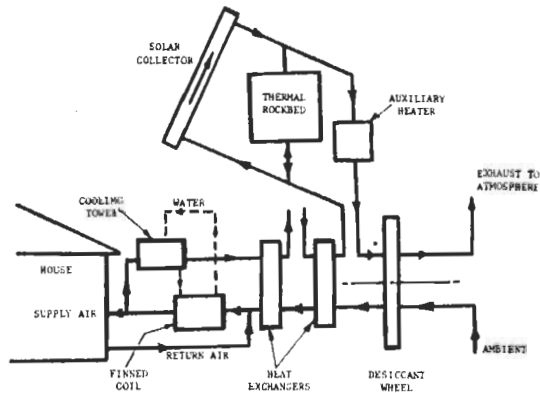

Fig. 3 'SENS' Cycle

exchanger (see Figure 3). It requires a cooling tower used with a finned coil heat exchanger to replace the evaporative coolers of the Pennington cycle. This has been investigated further by Tae Seok [10] and he predicts a COP of 2.58 assuming ideal components. Due to the additional heat exchanger and the nature of the finned coil and cooling tower components, this cycle is more complicated and expensive to construct than the Pennington cycle. The "REVERS" cycle proposed by Maclaine-Cross [9] and shown in Figure 4 is similar to the SENS cycle but simplified by eliminating one of the heat exchangers. Apparently the name "REVERS" was chosen for the reversible nature of the evaporative cooling in the finned coil. Tae Seok [10] predicted a COP of 1.25 for ARI conditions but again for unrealistic, ideal components. The low thermal COP's found in the Pennington cycle and recirculation cycle and the complexity of the "SENS" cycle have motivated the "DINC" (direct, indirect evaporative coolers) cycle proposed by Waugaman [2].

Figure 5 is a schematic of the DINC cycle and shows the psychrometric processes. A commercially available, plastic plate, indirect evaporative cooler followed by a direct evaporative cooler replaces the cooling-tower and finned-coil components of the "REVERS" cycle.

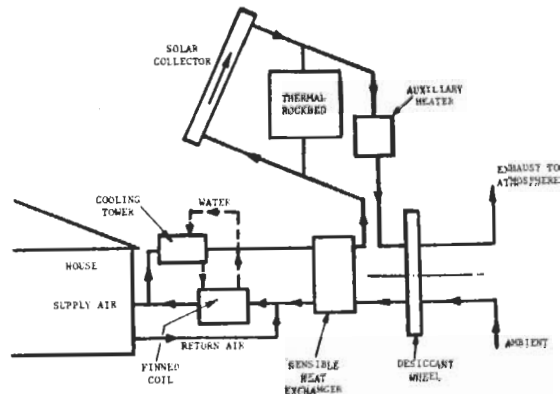

Fig. 4 'REVERS' Cycle

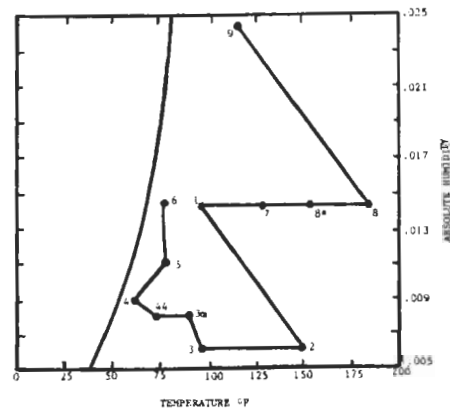
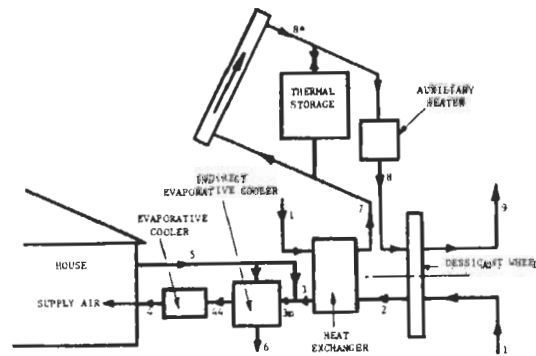

Fig. 5 'DINC' Cycle

Predicted COP's at ARI conditions, for the DINC cycle are shown in Table 1. The COP is a strong function of wheel size, desiccant fraction, flow ratios and regeneration temperatures. COP's range from 1.10 to 1.93. These estimates are based on a heat exchanger efficiency of 93%. The evaporative cooler efficiency is assumed to be 90%. The predicted COP's of the cycles described are summarized in Table 2. The DINC cycle is chosen for further study and a cooling season simulation (2) even though the SENS cycle appears more efficient in the table. The high value of COP for the SENS cycle is based on ideal components. Also, the DINC cycle has the advantages of simplicity and lower installation costs compared to the SENS cycle.

Table 1.

DINC Cycle Summary for 3 Tons of Cooling

R(ft)	P($\frac{min}{rev}$)	Raf	T _s	Z ₀ (ft)	α	T ₄	W ₄	Xmdtp($\frac{lb}{min}$)	COP
1.5	4	0.8	170	1.34	0.8	62.1	0.01124	133	1.66
1.5	12	0.8	170	1.34	0.8	62.7	0.01156	138	1.10
1.5	4	1.0	170	1.34	1.0	61.7	0.01109	132	1.62
1.5	4	0.8	170	1.34	0.6	62.5	0.0115	141	1.60
1.5	4	0.8	170	1.34	0.4	63.3	0.0117	144	1.59
1.5	4	0.8	170	1.34	0.2	64.4	0.0124	162	1.35
1.5	4	0.8	170	2.68	0.4	64.2	0.01234	151	1.81
1.5	4	0.8	170	2.68	0.8	63.0	0.01170	140	1.90
1.5	4	0.8	170	0.67	0.8	62.1	0.01125	134	1.40
1.75	4	0.8	170	1.34	0.8	62.1	0.01124	134	1.83
2.00	4	0.8	170	1.34	0.8	62.4	0.01140	136	1.93
1.5	4	0.8	160	1.34	0.8	62.7	0.01156	142	1.85
1.5	4	0.8	170	1.34	0.8	62.1	0.01124	133	1.66
1.5	4	0.8	185	1.34	0.8	61.1	0.0108	125	1.44
1.5	4	0.8	200	1.34	0.8	60.5	0.0105	120	1.26

Table 2.

Desiccant Cooling Cycle COP Values

Cycle	Investigators	COP
Pennington	Schlepp and Barlow [4]	1.2
Pennington	Jurinak, Mitchell, Beckman [5]	0.53 to 1.02
Pennington	Grolmes, Epstein [6]	1.4
Pennington	Exxon Tests [7]	1.1
Pennington	Majundar, Worek, and Lavan [8]	0.5
Recirculation	Majundar, Worek, and Lavan [8]	0.7
Recirculation	Jurinak, Mitchell, Beckman [5]	0.50 to 0.78
REVERS	Maclaine-Cross and Tae Seok [10]	1.25
SENS	Maclaine-Cross and Tae Seok [10]	2.58
DINC	Waugaman and Kettleborough	1.10 to 1.93

LIQUID DESICCANT SYSTEMS

Liquid desiccant systems are being considered for both heating and cooling. The characteristics of liquid systems offer several advantages over solid systems. Liquid desiccants can be regenerated on thin-film, open flow collectors that would be inexpensive to build. Energy is stored as chemical energy in the form of concentrated desiccant solution rather than thermal energy. This allows for greater energy storage and reduced reliance on auxiliary thermal energy sources. A simple system is shown in Figure 6.

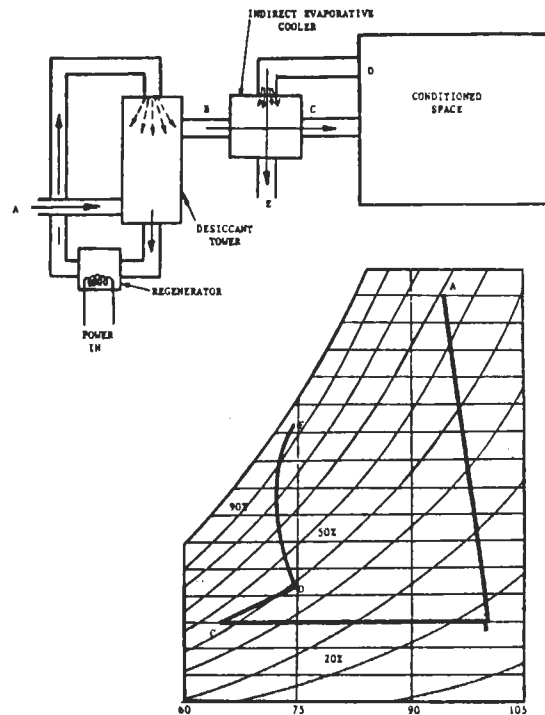

Fig. 6 Liquid Desiccant Cooling System

In the desiccant tower, water is removed from the air by the liquid desiccant (CaCl₂), which is regenerated by electric heat, gas, or solar energy. After drying, the air is passed through an indirect evaporative cooler (IEC) where cooling takes place without adding moisture to the air supplied to the house (the primary flow). Return air from the house acts as the secondary flow for the IEC. The process is shown on the psychrometric chart shown in Figure 6. In the liquid desiccant system the moisture in the air is absorbed by the desiccant (calcium chloride). There is a small exchange of heat; a heat and mass balance shows that the temperature change of the air is only a few degrees and in many cases cooling can take place. Regener-

ation of the desiccant solution involves a low pressure liquid pump to pass the desiccant through a low temperature heater. Overall, liquid desiccant systems have not received as much attention as solid systems and so development is not as advanced. Analytical and experimental work has concentrated mainly on the collector/regenerator. Little overall systems analysis has been done.

Griffiths [11] and Robinson [12] have proposed the system configuration shown in Figure 7. Return air from the conditioned space (1) contacts concentrated liquid desiccant solution in the absorber and is dehumidified. Simultaneously, the heat of absorption and possibly some sensible heat is rejected to the heat sink. This dried and cooled air (2) is then evaporatively cooled (3) and delivered to the conditioned space. During periods of favorable insolation, weak solution is pumped from storage and heated in the collector. Ambient air (6) is then contacted with the solution, removing moisture (7) and concentrating the solution.

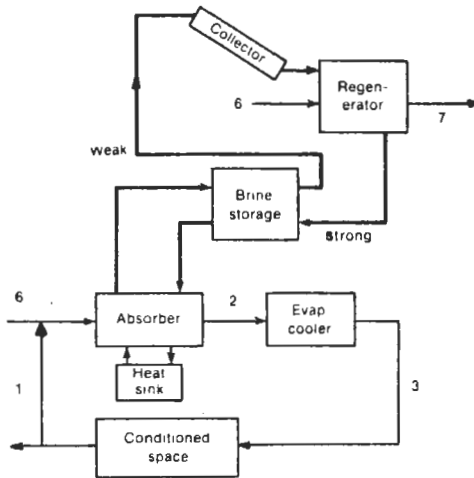

Fig. 7 Liquid Desiccant Cooling System Proposed by Griffiths

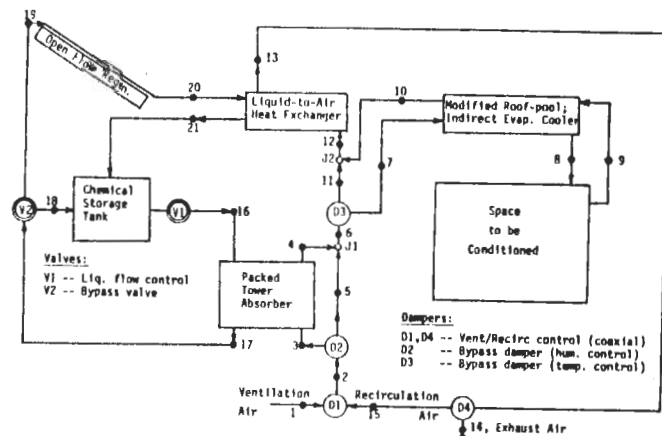

Fig. 8: Information Flow Diagram for the System Simulation Model

Robinson [12] has proposed using a thin-film, open flow collector for the collector and regenerator. A complete system using this concept was designed and installed in a test house. A counter-flow packed tower was used as the absorber and well water was used as the heat sink. The collector/regenerator was constructed of plywood coated with neoprene liquid roofing material and covered with low-iron glass. Calcium chloride solution was used as the desiccant. The system was operated for two cooling seasons. The average ratio of cooling supplied to incident solar energy was 0.6 and the electric COP was 2.9 [13]. Peng and Howell [14] have proposed another system; numerical analysis shows the thermal COP's to be of the order of 0.5.

Ullah [3] has investigated the system shown in Figure 8. The average seasonal thermal COP was found to be approximately 2.0 for a cooling season from April through October for Houston. A typical psychrometric chart is shown in Figure 9.

SUGGESTIONS FOR FURTHER RESEARCH

Most current research is concerned with solid desiccant systems. As the liquid desiccant system is simpler in many aspects it is recommended that this system be investigated in more detail. However it is also recommended that more emphasis be placed on experimental verification and investigation of the various components as well as the whole system.

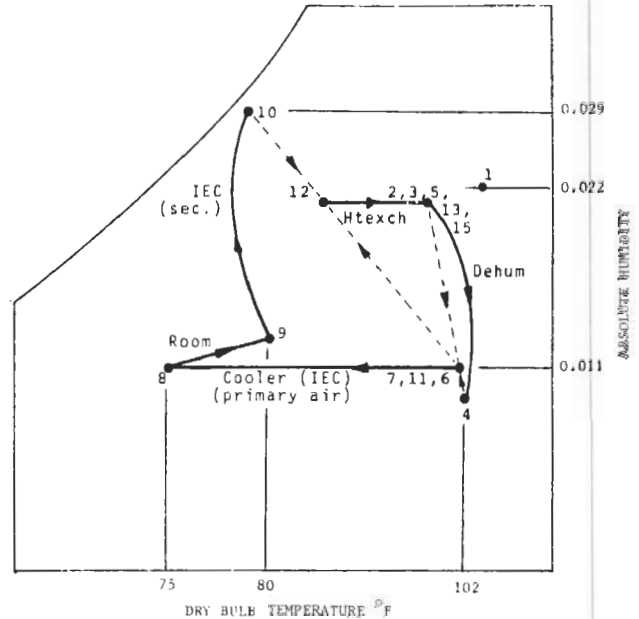

Fig. 9 Psychrometric Chart; Proposed System in Recirculation Mode

REFERENCES

1. Dennis R. Schlepp and Kenneth J. Schultz, "High Performance Solar Desiccant Cooling Systems," Solar Energy Research Institute, SERI/TR-252-2497, Colorado, September 1984.
2. D.G. Waugaman, "Thermodynamic Behavior with Cost Predictions of Residential Desiccant Cooling Systems," Ph.D. Dissertation, Texas A&M University, College Station, Texas 77843
3. M.R. Ullah, "Analysis of a Counterflow Indirect Evaporative Cooling and Liquid Desiccant Dehumidification System," Ph.D. Dissertation, Texas A&M University, College Station, Texas 77843.
4. D. Schlepp and R. Barlow, "Performance of the SERI Parallel Passage Dehumidifier," SERI/TR-252-1951, Colorado, September 1984.
5. J.J. Jurinak, J.W. Mitchell and W.A. Beckman, "Open-Cycle Desiccant Air Conditioning as an Alternative to Vapor Compression Cooling in Residential Applications," A.S.M.E. Journal of Solar Energy Engineering, Vol. 106, August 1984.
6. M.A. Grolmes and M. Epstein, "Desiccant Cooling System Performance: A Simple Approach," Final Report for the Gas Research Institute, Contract No. 5081-343-0502, 1982.
7. Exxon Corporation, "Advanced Solar/Gas Desiccant Cooling System," Final Report for the Gas Research Institute, Contract No. 5081-343-0477, 1981.
8. J.J. Majundar, W.M. Worek and Z. Lavan, "Performance of a Cross-Cooled Solar-Powered Desiccant Cooling System," Illinois Institute of Technology Report No. DES-81-1, 1982.
9. I.L. Maclaine-Cross, "A Theory of Combined Heat and Mass Transfer in Regenerators," Ph.D. Dissertation, Dept. of Mechanical Engineering, Monash University, Melbourne, Australia, 1974.
10. Kang Tae Seok, "Adiabatic Desiccant Open Cooling Cycles," M.Sc. Thesis, School of Mechanical and Industrial Engineering, The University of New South Wales, Australia, 1985.
11. W. Griffiths, U.S. Patent No. 4,164,125.
12. H. Robison, "Open-Cycle Chemical Heat Pump and Energy Storage Systems," Columbia: University of South Carolina, Coastal Carolina College, Energy Laboratory, January 1982.
13. H. Robison and H. Harris, "Year-round Operational Test Results of a Chemical Heat Pump Powered by Waste Heat, Off-peak Electricity, or Solar Energy," Energex '82: Conference Proceedings, Solar Energy Society of Canada, Regina, Saskatchewan, 1982.
14. C.S. Peng and J.R. Howell, "Optimization of Liquid Desiccant Systems for Solar/Geothermal Dehumidification and Cooling," Journal of Energy, Vol. 5, No. 6, 1981, pp. 401-408

SYMBOLS USED IN TABLE 1

- R = desiccant wheel outside radius
P = period of rotation of desiccant wheel
Raf = regeneration air fraction
 T_8 = regeneration temperature
 Z_0 = desiccant wheel length
 α = desiccant fraction
 T_4 = process air temp into house
 W_4 = process air humidity into house
 X_{mdotp} = process air mass flow rate