

CAPACITY DYNAMICS OF FEED-FORWARD, FLOW-MATCHING  
NETWORKS EXPOSED TO RANDOM DISRUPTIONS

A Dissertation

by

ALIAKSEI SAVACHKIN

Submitted to the Office of Graduate Studies of  
Texas A&M University  
in partial fulfillment of the requirements for the degree of

DOCTOR OF PHILOSOPHY

August 2005

Major Subject: Industrial Engineering

CAPACITY DYNAMICS OF FEED-FORWARD, FLOW-MATCHING  
NETWORKS EXPOSED TO RANDOM DISRUPTIONS

A Dissertation

by

ALIAKSEI SAVACHKIN

Submitted to the Office of Graduate Studies of  
Texas A&M University  
in partial fulfillment of the requirements for the degree of

DOCTOR OF PHILOSOPHY

Approved by:

Chair of Committee,	Martin A. Wortman
Committee Members,	Sila Çetinkaya
	Debra A. Elkins
	Georgia-Ann Klutke
	Thomas E. Wehrly
Head of Department,	Brett A. Peters

August 2005

Major Subject: Industrial Engineering

## ABSTRACT

Capacity Dynamics of Feed-Forward, Flow-Matching  
Networks Exposed to Random Disruptions. (August 2005)

Aliaksei Savachkin,

B.S., Belarussian State University of Informatics and Radioelectronics;

M.S., University of Colorado

Chair of Advisory Committee: Dr. Martin A. Wortman

While lean manufacturing has greatly improved the efficiency of production operations, it has left US enterprises in an increasingly risky environment. Causes of manufacturing disruptions continue to multiply, and today, seemingly minor disruptions can cause cascading sequences of capacity losses. Historically, enterprises have lacked viable tools for addressing operational volatility. As a result, each year US companies forfeit billions of dollars to unpredictable capacity disruptions and insurance premiums. In this dissertation we develop a number of stochastic models that capture the dynamics of capacity disruptions in complex multi-tier flow-matching feed-forward networks (FFN). In particular, we relax basic structural assumptions of FFN, introduce random propagation times, study the impact of inventory buffers on propagation times, and make initial efforts to model random network topology. These stochastic models are central to future methodologies supporting strategic risk management and enterprise network design.

## ACKNOWLEDGMENTS

I would like to thank Professor Martin Wortman for his continuous support and encouragement through the development of this dissertation. I also would like to thank the other members of my committee for their contribution of time and intellectual energy in this endeavor.

I would like to thank Debra Elkins, General Motors R&D Center, for her numerous insightful suggestions for improvement, assistance and encouragement.

On a more personal note, I would like to thank my parents, Alexander and Anna, for giving me the appreciation for learning and education, and my wife, Kseniya, for her support in completing this degree. Without their patience and faith in me, this achievement would not have been possible.

## TABLE OF CONTENTS

CHAPTER		Page
I	INTRODUCTION . . . . .	1
II	LITERATURE REVIEW . . . . .	4
III	BASIC ANALYSIS OF FFN . . . . .	9
	A. Terminology and notation . . . . .	10
	B. Basic model and main result . . . . .	11
	C. Interpretation of the main result in terms of paths . . . . .	15
IV	EXTENDED ANALYSIS OF FFN . . . . .	19
	A. Relaxing structural assumptions of FFN . . . . .	19
	B. Modeling propagation times . . . . .	23
	C. Special case: Serial FFN . . . . .	32
	D. Modeling the impact of inventory buffers . . . . .	36
	E. Modeling random network topology . . . . .	44
V	STOCHASTIC MODELS FOR AVAILABLE EFFECTIVE CAPACITY OF THE NETWORK . . . . .	49
	A. Stepwise capacity loss with instantaneous recovery . . . . .	51
	B. Instantaneous capacity loss with instantaneous recovery . . . . .	55
	C. Instantaneous capacity loss with constant recovery rate . . . . .	62
	D. Constant rate capacity loss with constant recovery rate . . . . .	70
VI	CONCLUSIONS AND FUTURE RESEARCH . . . . .	76
	REFERENCES . . . . .	79
	VITA . . . . .	84

## LIST OF FIGURES

FIGURE	Page
1	Numbering scheme in a FFN. . . . . 10
2	Available supply capacity of vertex $i$ . . . . . 13
3	Vertex $j$ has multiple paths. . . . . 16
4	Modeling a direct multi-tier connection between vertices $j$ and $i$ . . . 20
5	Introducing dummy vertices. . . . . 20
6	Modeling re-entrant flow. . . . . 22
7	Reconfiguring the network to eliminate re-entrant flow. . . . . 22
8	Overlapping and non-overlapping paths of a vertex. . . . . 27
9	A serial feed-forward network. . . . . 32
10	Modeling a flow balanced network. . . . . 36
11	Conversion from a flow balanced network to a serial network. . . . . 38
12	Tier-1 suppliers of vertex $i$ . . . . . 38
13	Impact of disruptions and inventory buffers. . . . . 39
14	Impact of disruptions: case of graceful capacity recovery. . . . . 42
15	Independence of multifurcation coefficients. . . . . 45
16	Stepwise capacity loss with instantaneous capacity recovery. . . . . 51
17	$\{C_{p_j}(t)\}$ process of model 1. . . . . 53
18	Corresponding $\{B_t^u\}$ process of model 1. . . . . 53
19	Instantaneous capacity loss with instantaneous recovery. . . . . 56

FIGURE	Page
20	$\{C_{p_j}(t)\}$ process of model 2. . . . . 58
21	Corresponding $\{B_t^u\}$ process of model 2. . . . . 58
22	Instantaneous capacity loss with constant rate recovery. . . . . 63
23	Corresponding $\{B_t^u\}$ process of model 3. . . . . 63
24	$\{C_{p_j}(t)\}$ process of model 3. . . . . 66
25	Including random delay time $R_n$ in model 3. . . . . 67
26	Corresponding $\{B_t^u\}$ process of the model. . . . . 68
27	Loss with a constant rate $\beta$ , recovery with a constant rate $\alpha$ . . . . . 70
28	$\{C_{p_j}(t)\}$ process of model 4. . . . . 74
29	$\{B_t^u\}$ process when $u = C^*$ of model 4. . . . . 74

## CHAPTER I

## INTRODUCTION

Lean business practices are widely accepted and deployed in modern manufacturing enterprises. Estimates suggest that the shift to just-in-time scheduling in the US automotive industry has saved companies more than \$1 billion a year in inventory costs, alone. Unfortunately, while lean manufacturing has dramatically boosted operational efficiency, it has also left companies highly vulnerable to capacity disruptions. According to a recent survey by A.M. Best Company, Inc. of 600 executives, 69 percent of chief financial officers, treasurers and risk managers at Global 1,000 companies in North America and Europe view property-related hazards—such as fires and explosions—and supply chain disruptions as the leading threats to top revenue sources. Causes of manufacturing disruptions continue to multiply, and, today, seemingly minor disruptions can rapidly starve downstream operations.

Global outsourcing has greatly reduced costs, but at the same time it has increased risk exposure. The recent outbreak of Severe Acute Respiratory Syndrome (SARS) in China and Singapore forced most electronics and hardware factories there to suspend operations for days, and several Motorola plants shut down. In December 2002, a political strike in Venezuela made transnational businesses including GM, BP, Ford, Goodyear and Procter & Gamble to suspend their manufacturing for the duration of the conflict.

Enterprises are consolidating their internal and external suppliers to gain economies of scale at the expense to exposure of supply chain disruption. In September 2002, longshoremen on the US West Coast were locked out in a labor strike for 11 days,

---

The journal model is *IEEE Transactions on Automatic Control*.



forcing the shutdown of 29 ports. With more than \$300 billion of dollars in goods shipped annually through these ports, the dispute caused between \$11 and \$22 billion in lost sales, spoiled perishables and underutilized capacity.

Accidents and natural disasters also impact production capacity. In 1999 an earthquake in Taiwan displaced power lines to the semiconductor fabrication facilities responsible for more than 50 percent of the worldwide supplies of memory chips, circuit boards, and other computer components. Estimates show it shaved 5 percent off earnings for hardware manufacturers including Dell, Apple, Hewlett-Packard, IBM, and Compaq.

Man-made disasters are on the rise, from terrorist attacks to computer viruses. In January 2003, a computer virus named SQL Sapphire caused nearly \$1 billion in damage by overloading the global network. Continental Airlines was forced to delay flights, and Bank of America's ATMs shut down.

These and many other examples of catastrophic capacity disruptions illustrate the fact that enterprises increasingly depend on a complicated multi-tier network of global suppliers and partners, thus boosting the risk of the entire system if a member of the network loses its capacity, even temporarily. Often managers fail to recognize risk because they do not have a sufficient understanding of the enterprise network.

Historically companies have developed relatively sophisticated techniques for dealing with financial risk [1]. Tools to address operational disruptions are considerably less developed, and traditionally risk has been traded to insurance companies. Insurance does not eliminate or even reduce risk of operational disruptions, rather it only provides an indemnity by cushioning the impact of financial losses. As a result, each year US companies forfeit billions of dollars to unpredicted disruptions and insurance premiums. Risk managers need new methods to measure and manage operational disruptions at a strategic level.

The research developed here is focused on developing stochastic models for capturing capacity dynamics in complex multi-tier flow-matching feed-forward networks (FFN).

This dissertation is organized as follows. A review of the related literature is given in Chapter II. In Chapter III we introduce terminology and notation, present a basic production enterprise multi-tier flow-matching FFN, and obtain an expression for available effective capacity of a network in terms of available production capacities of individual vertices. Derivation of the distribution of network available effective capacity follows from the basic analysis. A useful interpretation of the main result in terms of paths allows us to relax certain structural assumptions of the feed-forward architecture in Chapter IV, and introduce random propagation times, study the impact of capacity disruptions and inventory buffers, and model random network topology. Chapter IV also presents a special case of FFN called serial FFN (SFFN). In Chapter V we develop a number of stochastic models which characterize certain dynamics of available production capacity at network vertices, which along with the main result from Chapter III, allow to obtain the limiting distribution of available effective capacity of the entire network. Finally, the contributions and conclusions of this research are reviewed in Chapter VI.

## CHAPTER II

### LITERATURE REVIEW

While there is a wealth of literature on production and inventory control, supply chain, manufacturing systems, and operations, only a small portion of the open research has been dedicated to modeling the impact of various disruptions such as demand patterns, supplier and production lead times, prices, imperfect process quality, process yield, etc. Most of the recent literature focuses on minimizing costs of supply chain operations (see, for example, [2, 3, 4, 5, 6]); there appear to be very few results on managing production disruptions.

One of the most common types of disruption appearing in the production/inventory control and supply chain literature is that of supply rate changes. The work was pioneered by [7] who offer a model of a single-stage production with a constant demand where the supply was subject to a random failure. Under the assumption of Poisson machine failures, a fixed storage capacity and no setup time and/or setup cost, the authors derived performance measures, such as average inventory level and the fraction of time demand was met, for either exponentially distributed or constant repair times. [8] extends this work to the case where demand follows a compound Poisson distribution. An explicit closed form solution for the steady-state distribution of the inventory level is derived, and this result is then used to compute system performance indices of interest related to service level to customers and machine utilization.

More recently [9] explores the management of inventory for stochastic-demand systems, where the products supply is randomly disrupted for periods of random duration. The analysis yields the optimal values of the policy parameters, explores the impact on the optimal values of the policy parameters of variations in the average frequency and duration of supply disruptions, and of variations in the fraction of

stockouts that are backordered, and provides insight into the optimal inventory strategy when there are changes in the severity of supply disruptions or in the behavior of unfilled demands. [10] study the classic economic order quantity (EOQ) problem with supply disruptions, and [11] consider a order-quantity/reorder-point inventory models with two suppliers subject to independent disruptions to compute the exact form of the average cost expression. For the multiple-supplier problem, assuming that all the suppliers have similar availability characteristics, the authors develop a simple model and show that as the number of suppliers becomes large, the model reduces to the classical EOQ model. [12] presents an analytical model for computing the stationary distribution of the on-hand inventory in a continuous-review inventory system with compound Poisson demand, Erlang distributed lead time, and lost sales, where the supplier can assume one of the two "available" and "unavailable" states at any point in time according to a continuous-time Markov chain. Exact analytical expressions are derived for the special case where demand sizes are exponentially distributed, and some cost minimization numerical results are presented. Other work on production-inventory systems with deterministic demand and supply disruptions includes [13, 14, 15, 16].

Papers addressing both supply disruptions and random demand include [17, 18, 19]. [17] proposes a dynamic model concerning optimal inventory policies in the presence of market disruptions, which are often characterized by events with uncertain arrival time, severity and duration. [18] considers a continuous-review stochastic inventory problem with random demand and random lead-time where supply may be disrupted due to machine breakdowns, strikes or other randomly occurring events. [19] explore an inventory-control model which includes a detailed Markovian model of the resupply system. A number of papers which address supply and demand changes have been developed in the field of oil stockpiling, as there has been grave concern

over the oil supply from the Middle East. For examples see [20, 21, 22].

Modeling production rate disruptions (machine failures) challenged many researchers for several decades, and numerous research efforts have been devoted to extending classical economic manufacturing quantity (EMQ) models. [23] derive an EMQ model when the production process is subject to a random deterioration from an in-control state to an out-of control state. [24] proposes a model to determine an optimal lot size under the following assumptions: while producing a lot, each time it produces an item the process can go out-of control with a given probability, and the process continues to produce defective items until the entire lot is produced. The process is presumed to be in control before starting production of a new lot. [25] models the defect-generating process in the semiconductor wafer probe process to determine an optimal lot size, which reduces the average processing time on a critical resource. [26] presents a simple approximation of the EMQ model with Poisson machine breakdowns and low failure rate. [27] study an unreliable production system with constant demand and random breakdowns, with the focus on the effects of machine failure and repair on optimal lot-sizing decisions. Assuming exponentially distributed time between failures and instantaneous repair of the machine, authors derive some unique properties of their model compared to the classical EMQ model. Since it is assumed that machine restoration times are negligible, [27] only address the lot-sizing problem. [28] extend their earlier work in [27] to the case where repair times are randomly distributed and excess demand is lost.

[29] propose an extension to the model in [28], which determines an optimal lot size when a machine is subject to random failures and the time to repair is constant. They formulate average cost functions for the optimal lot size, and derive conditions for determining the optimal lot size. [30] presents a model that assumes the  $(s, S)$  control policy. With Poisson failures and exponential repair times, a cost function is

derived. Among other notable examples of such works are [31] and [32].

The topic of system unreliability in the production/inventory context has also attracted interest among operations management researchers as represented in the sample of works we describe here. [8] superimpose the reliability feature comprising the machine failure process and the ensuing repair actions. [13] investigate the optimality of zero-inventory policies in production systems with uncertain manufacturing capacity. [14] and [15] examine the classical economic lot-sizing model with single and multiple disruptions. [33] analyze a single localized unreliable bottleneck facility with a constant production and demand rate that is subject to random disruptions. The time between breakdowns is assumed to be exponentially distributed while the restoration times are constant. The authors employ an  $(s, S)$  production policy and develop expressions for evaluating the probability distribution of the number of production runs in a cycle together with its first two moments, the average cycle time, the average on-hand inventory and backorder levels, and the expected total cost rate of the system. In addition, they investigate the behavior and the properties of the average total cost rate and the policy parameters with changes in reliability and other system parameters. However, the authors leave to future work the case of random demand and/or production rates and a stochastic duration of the disruption period.

[34] examines a single machine production and inventory system with a deterministic production and demand rate, when the machine is subject to random failures. The machine times to failure and repair times are random, and during repairs, demand is backordered as long as the backordering level does not exceed a prescribed amount, after which demand is lost. Considering time in discrete units and the times to failure and repair times to be geometrically distributed, the author models the production/inventory system as a Markov chain and develops an algorithm to compute the potentials that are used to formulate the cost function. [35] presents an integrated

model for determining an economic manufacturing quantity, inspection schedule and control chart design of an imperfect production process, where he assumes that the process is subject to the occurrence of a non-Markovian shock having an increasing failure rate.

Temporary price changes (disruptions) have also attracted interest among operations management researchers. Basic price discount models were formulated in the 1960s (e.g., [36]). [37] extend the basic model to situations in which the price change becomes effective at any time in the future (originally - at the end of the next cycle). [38] extends the model to situations in which there are limits on the quantities that could be purchased at the discounted price. [39] analyze the price disruption interval by looking at a minimal order quantity on discounted purchases and determine optimal policies for various cases. [40] focus on a short disruption period that allows only one special purchase. [41] emphasizes the differences between a net present value model as opposed to a no-discount model for temporary price reduction.

To summarize, all production and inventory control, supply chain, manufacturing systems, and operations literature, which consider various types of disruptions, focus on traditional localized issues of inventory, production lot sizing, production scheduling, cost management of inventory, setup, and backorder costs. At a strategic level, there is a need to explore enterprise-wide disruptions with focus on strategic enterprise design and enterprise risk management decisions. We offer a modeling paradigm suitable for capturing the stochastic dynamics of capacity in complex feed-forward flow-matching networks exposed to disruptions that occur anywhere across the enterprise. Particular emphasis is given to constructing a number of stochastic models characterizing capacity dynamics at point of delivery, which in conjunction with demand dynamics, will provide the analytical foundation necessary to model network risk.

## CHAPTER III

### BASIC ANALYSIS OF FFN

We treat a manufacturing enterprise as a flow-matching network which receives a supply of raw materials, parts and services, and assembles them, in a prespecified technological sequence using manufacturing resources, to produce items and deliver them to the point of consumption. Manufacturing resources belong to the enterprise but materials, parts and logistics services may be supplied both internally and externally. Operations are a multi-step sequence, and so we combine suppliers, assembly and distributors in tiers in accordance with the sequence. Managing enterprise topology at a strategic level allows an assumption that the flow of assembly is not re-entrant. Hence, we model the enterprise infrastructure as a multi-tier flow-matching FFN. FFN have a characteristic layered architecture with each tier comprising one or more simple assembly units as vertices. Each vertex is connected to one or more other vertices by edges which represent flow of materials and parts. Each vertex is responsible for a single assembly operation. The reader is referred to [42] for a basic exposition of FFN.

This chapter is organized as follows. In section A we introduce terminology and notation. Section B identifies underlying assumptions, presents a basic structural model for enterprise topology as a multi-tier flow-matching FFN, and gives an expression for available effective capacity of the network in terms of available production capacities of individual vertices. Finally, in section C, we propose a useful interpretation of the main result in terms of paths, followed by derivation of the distribution of available effective capacity of the network.



### A. Terminology and notation

Suppose we have a feed-forward flow-matching network  $N$  with a finite number of vertices  $n \geq 2$  arranged in a fixed number of tiers  $m \geq 2$  ( $m \leq n$ ) so that each tier contains at least one vertex. Tiers are numbered in ascending order starting from tier 1 (on the far right) which represents point of delivery and moving upstream from right to left. The first input tier (farthest left in Figure 1) is assigned to be tier  $m$ . Tier  $m$  is typically where raw materials enter the network. Vertices are numbered in ascending order from 1 to  $n$  according to their position in tiers starting from tier 1 and moving to left, and from top to bottom within a tier, so that lower-numbered vertices belong to lower-numbered tiers (see Figure 1).

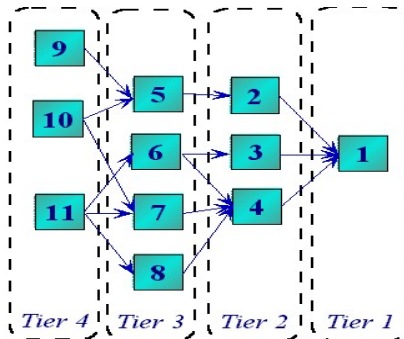

Fig. 1. Numbering scheme in a FFN.

Let  $N_k$  be the set of all vertices that belong to tier  $k$ ,  $k = 1, 2, \dots, m$ . For example, in Figure 1,  $N_1 = \{1\}$ ,  $N_2 = \{2, 3, 4\}$ , etc. We have  $N_k \cap N_l = \emptyset$ ,  $k, l = 1, 2, \dots, m$ ,  $k \neq l$ , and  $\bigcup_{k=1}^m N_k = N = \{1, 2, \dots, n\}$ . We introduce the following terminology.

*Throughput* is a long-run average of the number of units of finished product per unit time flowing through a vertex. Each vertex has a demand which is the number

of units of raw material or parts consumed by the vertex to produce a single unit of finished product. This transformation is required to express network flows in common production units; thus, vertex capacities are measured in the same units.

*Available production capacity of vertex  $j$* , denoted  $C_{p_j}(t)$ ,  $j \in N$ , and fixed  $t > 0$ , is the maximum throughput that production resources of vertex  $j$  are capable of sustaining at time  $t$ .

*Available supply capacity of vertex  $j$* , denoted  $C_{s_j}(t)$ ,  $j \in N$ , and fixed  $t > 0$ , is the maximum throughput that supply of raw materials to vertex  $j$  is capable of sustaining at time  $t$ . Both  $C_{p_j}(t)$  and  $C_{s_j}(t)$  are positive bounded random variables.

*Available effective capacity of vertex  $j$* , denoted  $C_{e_j}(t) = \min \{C_{p_j}(t), C_{s_j}(t)\}$ . Vertex effective capacity is the maximum output throughput that the vertex can produce.

*Multifurcation coefficient*,  $0 \leq A_{ji} \leq 1$ ,  $i, j \in N$ ,  $j > i$ , is the proportion of the effective capacity of vertex  $j$  designated to serve the destination node  $i$ .

$$A_{ji} = \begin{cases} 0, & \text{if vertices } i \text{ and } j \text{ are disconnected.} \\ 1, & \text{if vertex } i \text{ is the only receiver of vertex } j\text{'s output.} \end{cases}$$

We are ready to proceed with our basic network topology model.

### B. Basic model and main result

We accept the following *assumptions* for our basic enterprise network model:

1. Network configuration is fixed, i.e., network structure is provided for a fixed instant of time so that values of  $N_k$  and  $A_{ji}$  are known with certainty for all  $i, j \in N$ ,  $k = 1, \dots, m$ . Modeling an enterprise network with a fixed topology is suitable when all structural relationships among suppliers are known.

2. The enterprise has a single point of delivery, i.e., the network flow converges to a single output vertex. This vertex is  $j = 1$ .
3. Available production capacities are independent for all vertices. This is typically true when assembly locations are remotely separated and/or operations of different locations are managed independently. This assumption may not be reasonable for capacity disruptions generated by events impacting labor, as well as disruptions affecting common infrastructure.
4. Propagation times between nodes are negligible. Propagation times include transportation times only.
5. Enterprise has no inventory buffers.

Assumptions 1, 4, and 5 will be later relaxed.

With the above assumptions the following basic properties of FFNs must be true:

**Property 1.**  $N_1 = \{1\}$ ,  $\{2\} \in N_2$ ,  $\{n\} \in N_m$ .

**Property 2.**  $\forall j \in N_2$ ,  $A_{j1} = 1$ . This follows from assumption 2 above.

**Property 3.**  $A_{ij} = 0 \forall i, j \in N$ , s.t.  $i < j$ . This constraint along with the numbering scheme characterize feed-forward flow.

**Property 4.**  $\forall j \in N_{k+s}$ ,  $i \in N_k$ ,  $A_{ji} = 0$ , where  $k = 1, 2, \dots, m$ ;  $s \geq 2$ . Equivalently,  $\forall i, j \in N$ ,  $A_{ji} > 0 \Rightarrow j \in N_{k+1}$ ,  $i \in N_k$  for some  $k$ . This means that a vertex can only source vertices in its immediately succeeding tier. The converse statement  $j \in N_{k+1}$ ,  $i \in N_k$ ,  $k = 1, 2, \dots, m \Rightarrow A_{ji} > 0$ , does not necessarily hold, since we do not require a vertex be connected to *all* vertices in its preceding and/or succeeding tier; we only require that a vertex be connected to a nonempty proper subset of the tiers. However,  $j \in N_{k+1}$ ,  $i \in N_k$ ,  $k = 1, 2, \dots, m \Rightarrow A_{ji} \geq 0$  always holds.

**Property 5.**  $\forall i, j \in N_k, A_{ji} = 0$ . This follows from the observation that a vertex is not connected to any of the vertices in the tier it belongs to (including itself).

**Property 6.**  $\forall j \in N_k, \exists$  at least one  $i \in N_{k-1}$ , s.t.  $A_{ji} > 0$ , where  $k = 1, 2, \dots, m$ . Thus, every vertex  $j$  above point of delivery has at least one vertex recipient of its output.

Available supply capacity of any vertex  $i \in N_k$  can be expressed as follows (see Figure 2):

$$C_{s_i}(t) = \min_{\substack{j \in N_{k+1} \\ A_{ji} > 0}} \{A_{ji} C_{e_j}(t)\} = \min_{\substack{j \in N \\ A_{ji} > 0}} \{A_{ji} C_{e_j}(t)\}. \quad (3.1)$$

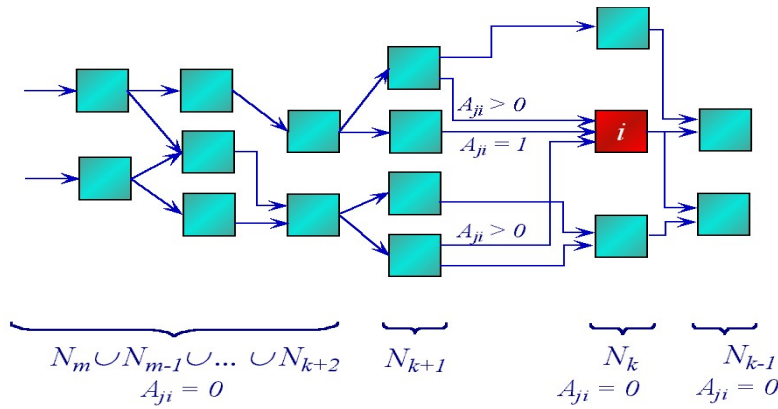

Fig. 2. Available supply capacity of vertex  $i$ .

It follows immediately from property 2 that, for point of delivery, available supply capacity is given by:

$$C_{s_1}(t) = \min_{j \in N_2} \{A_{j1} C_{e_j}(t)\} = \min_{j \in N_2} \{C_{e_j}(t)\}. \quad (3.2)$$

We have the following little lemma:

**Lemma 1** For any vertex  $i \in N_k, k < m$ ,

$$C_{e_i}(t) = \min_{\substack{j \in N_{k+1} \\ A_{ji} > 0}} \{C_{p_i}(t), A_{ji} C_{e_j}(t)\} = \min_{\substack{j \in N \\ A_{ji} > 0}} \{C_{p_i}(t), A_{ji} C_{e_j}(t)\}.$$

*Proof.* We use (3.1) and properties (3), (4), and (5) of FFNs:

$$\begin{aligned} C_{e_i}(t) &\stackrel{\text{def}}{=} \min\{C_{p_i}(t), C_{s_i}(t)\} \\ &= \min\{C_{p_i}(t), \min_{\substack{j \in N_{k+1} \\ A_{ji} > 0}} \{A_{ji} C_{e_j}(t)\}\} \\ &= \min_{\substack{j \in N_{k+1} \\ A_{ji} > 0}} \{C_{p_i}(t), A_{ji} C_{e_j}(t)\} \\ &= \min_{\substack{j \in N \\ A_{ji} > 0}} \{C_{p_i}(t), A_{ji} C_{e_j}(t)\}. \end{aligned}$$

■

We can now introduce the central proposition of this chapter, which gives an expression for available effective capacity at point of delivery, for a fixed time, in terms of available production capacities of all network vertices.

**Proposition 1** *Available effective capacity at point of delivery, for a fixed time  $t \geq 0$ , is given by*

$$C_{e_1}(t) = \min_{\substack{M=2,3,\dots,m \\ i_1 \in N_1, i_2 \in N_2, \dots, i_m \in N_m \\ A_{i_k i_{k-1}} > 0 \forall k=1, \dots, m}} \{C_{p_1}(t), C_{p_{i_M}}(t) \prod_{k=2}^M A_{i_k i_{k-1}}\},$$

provided that  $C_{e_i}(t) = C_{p_i}(t) \forall i \in N_m$ .

*Proof.* Condition  $C_{e_i}(t) = C_{p_i}(t) \forall i \in N_m$  means that input tier  $N_m$  has no suppliers. To prove the result we move recursively upstream from vertex one and consider each tier. For fixed  $t \geq 0$ ,

$$\begin{aligned} C_{e_1}(t) &\stackrel{\text{def}}{=} \min\{C_{p_1}(t), C_{s_1}(t)\} \\ &= \min\{C_{p_1}(t), \min_{i \in N_2} \{C_{e_i}(t)\}\} && \text{by (3.2)} \\ &= \min_{h \in N_1, i \in N_2} \{C_{p_h}(t), C_{e_i}(t)\} && \text{consolidating } \min \text{ arguments} \end{aligned}$$

$$\begin{aligned}
&= \min_{h \in N_1, i \in N_2} \{C_{p_h}(t), \min_{\substack{j \in N_3 \\ A_{ji} > 0}} \{C_{p_i}(t), A_{ji} C_{e_j}(t)\}\} \\
&= \min_{h \in N_1, i \in N_2} \{C_{p_h}(t), C_{p_i}(t), \min_{\substack{j \in N_3 \\ A_{ji} > 0}} \{A_{ji} C_{e_j}(t)\}\} \\
&= \min_{\substack{h \in N_1, i \in N_2, j \in N_3 \\ A_{ji} > 0}} \{C_{p_h}(t), C_{p_i}(t), A_{ji} C_{e_j}(t)\} \\
&= \min_{\substack{h \in N_1, i \in N_2, j \in N_3 \\ A_{ji} > 0}} \{C_{p_h}(t), C_{p_i}(t), A_{ji} \min_{\substack{k \in N_4 \\ A_{kj} > 0}} \{C_{p_j}(t), A_{kj} C_{e_k}(t)\}\} \\
&= \min_{\substack{h \in N_1, i \in N_2, j \in N_3, k \in N_4 \\ A_{ji} > 0, A_{kj} > 0}} \{C_{p_h}(t), C_{p_i}(t), A_{ji} C_{p_j}(t), A_{ji} A_{kj} C_{e_k}(t)\} \\
&= \min_{\substack{h \in N_1, i \in N_2, j \in N_3, k \in N_4 \\ A_{ji} > 0, A_{kj} > 0}} \{C_{p_h}(t), C_{p_i}(t), A_{ji} C_{p_j}(t), A_{ji} A_{kj} \min_{\substack{l \in N_5 \\ A_{lk} > 0}} \{C_{p_k}(t), A_{lk} C_{e_l}(t)\}\} \\
&\dots \\
&= \min_{\substack{M=2,3,\dots,m \\ i_1 \in N_1, i_2 \in N_2, \dots, i_m \in N_m \\ A_{i_k i_{k-1}} > 0 \forall k=1, \dots, m}} \{C_{p_1}(t), C_{p_{i_M}}(t) \prod_{k=2}^M A_{i_k i_{k-1}}\}.
\end{aligned}$$

■

Available effective capacity at point of delivery, for fixed  $t \geq 0$ , is therefore the minimum of available production capacities of each vertex multiplied by the product form  $\prod_{k=2}^M A_{i_k i_{k-1}}$ , where  $M = 2, 3, \dots, m$ ;  $i_1 \in N_1, \dots, i_m \in N_m$ ;  $A_{i_k i_{k-1}} > 0 \forall k = 1, \dots, m$ .

### C. Interpretation of the main result in terms of paths

In order to gain intuition about Proposition 1, we need additional terminology. We define the  $i^{\text{th}}$  path from vertex  $j \in N_k$  to point of delivery as a set of vertices

$$L_j^i = \{j, j_1^i \in N_{k-1}, j_2^i \in N_{k-2}, \dots, 1 \in N_1 : A_{j j_1^i} > 0, A_{j_1^i j_2^i} > 0, \dots, A_{j_{k-2}^i 1} > 0\}, \quad (3.3)$$

where  $i \in \mathbb{N}$ . Each vertex  $j$  in the network has at least one unique path  $L_j^1$ ; this

follows from property 6 of FFNs. In fact, the number of unique paths a vertex  $j$  can have (see Figure 3) is no smaller than  $\text{card}(\{i \in N : A_{ji} > 0\})$ . Paths  $L_j^1$  and  $L_j^2$  are unique, if, in terms of sets,  $L_j^1 \neq L_j^2$ .

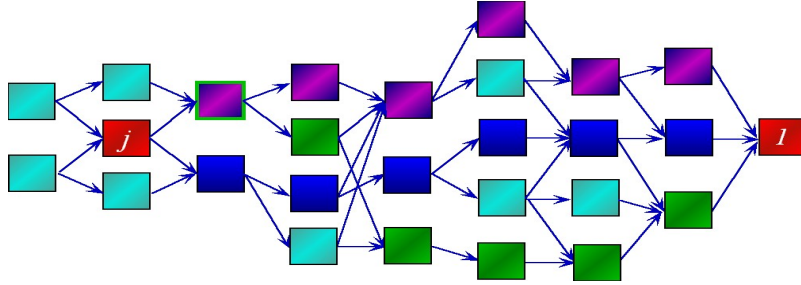

Fig. 3. Vertex  $j$  has multiple paths.

For each unique path  $L_j^i$  of vertex  $j$ ,  $i \in \mathbb{N}$ , we let the product of the corresponding multifurcation coefficients be as

$$A_j^i = A_{jj_1^i} A_{j_1^i j_2^i} \dots A_{j_{k-2}^i j_{k-1}^i}, \quad (3.4)$$

and then take the minimum over all unique paths  $i$  from  $j$  to point of delivery:

$$\bar{A}_j = \min_i \{A_j^i\}. \quad (3.5)$$

Now we can rewrite the result of Proposition 1 as:

**Proposition 2** *Available effective capacity at point of delivery, for a fixed time  $t \geq 0$ , is given by*

$$C_{e_1}(t) = \min_{j \in N} \{\bar{A}_j C_{p_j}(t)\}.$$

*Proof.* From Proposition 1 we have

$$\begin{aligned} & \min_{\substack{M=2,3,\dots,m \\ i_1 \in N_1, i_2 \in N_2, \dots, i_m \in N_m \\ A_{i_k i_{k-1}} > 0 \forall k=1, \dots, m}} \{C_{p_1}(t), C_{p_{i_M}}(t) \prod_{k=2}^M A_{i_k i_{k-1}}\} = \\ & = \min_{M=2,3,\dots,m} \{C_{p_1}(t), C_{p_{i_M}}(t) \min_{\substack{i_1 \in N_1, i_2 \in N_2, \dots, i_m \in N_m \\ A_{i_k i_{k-1}} > 0 \forall k=1, \dots, m}} \{\prod_{k=2}^M A_{i_k i_{k-1}}\}\}. \end{aligned}$$

For each fixed vertex  $i_M$ , the expression  $C_{p_{i_M}}(t) \prod_{k=2}^M A_{i_k i_{k-1}}$ , where  $i_1 \in N_1, i_2 \in N_2, \dots, i_m \in N_m; A_{i_k i_{k-1}} > 0$ , is equivalent to  $C_{p_{i_M}}(t) A_{i_M}^i$  for some path  $i$  of the vertex  $i_M$ . Then

$$C_{p_{i_M}}(t) \min_{\substack{i_1 \in N_1, i_2 \in N_2, \dots, i_m \in N_m \\ A_{i_k i_{k-1}} > 0 \forall k=1, \dots, m}} \{\prod_{k=2}^M A_{i_k i_{k-1}}\} = C_{p_{i_M}}(t) \min_i \{A_{i_M}^i\} = C_{p_{i_M}}(t) \bar{A}_{i_M}.$$

Finally, available effective capacity of point of delivery is given by

$$C_{e_1}(t) = \min_{j \in N} \{\bar{A}_j C_{p_j}(t)\}. \quad \blacksquare$$

Proposition 2 expresses available effective capacity at point of delivery as a minimum of available production capacities of individual vertices multiplied by a factor  $\bar{A}_j$ . To obtain  $\bar{A}_j$  for each vertex we identify all unique paths from the vertex to point of delivery, then for each path calculate its product of multifurcation coefficients  $A_j^i$  as in (3.4), and take the minimum over all paths as in (3.5). We are now in a position to state the main result of this chapter

**Proposition 3** *The complimentary distribution of available effective capacity of a network, for fixed  $t \geq 0$ , is the product of complimentary distributions of available production capacity of individual vertices*

$$\bar{F}_{C_{e_1}(t)}(\alpha) = P\{C_{e_1}(t) > \alpha\} = \prod_{j=1}^n \bar{F}_{C_{p_j}(t)}(\alpha/\bar{A}_j).$$



*Proof.* We use Proposition 2 and the assumption that available production capacities of all vertices are independent.

$$\begin{aligned}
\bar{F}_{C_{e_1}(t)}(\alpha) &= P\{C_{e_1}(t) > \alpha\} \\
&= P\{\min_{j \in N} \{\bar{A}_j C_{p_j}(t)\} > \alpha\} \\
&= P\{\bar{A}_1 C_{p_1}(t) > \alpha, \bar{A}_2 C_{p_2}(t) > \alpha, \dots, \bar{A}_n C_{p_n}(t) > \alpha\} \\
&= \prod_{j=1}^n P\{\bar{A}_j C_{p_j}(t) > \alpha\} = \prod_{j=1}^n \bar{F}_{C_{p_j}(t)}(\alpha/\bar{A}_j).
\end{aligned}$$

■

In this chapter we have developed the basic underlying structural model of an enterprise as a flow-matching FFN. We have chosen available effective capacity at point of delivery as a measure of overall performance of the network. In the presence of independent operations, available effective capacity of the enterprise is the minimum of available production capacities of individual vertices. Proposition 3 reveals the relationship between probability law on network capacity and probability law on vertex capacity. The proposition leads to an important observation that, for relatively small (e.g.,  $n = 30$ ) and reliable networks (with relatively high probabilities of exceeding a certain capacity level for individual vertices, e.g.,  $P\{\bar{A}_j C_{p_j}(t) > \alpha\} = 0.95$ ), we could have the corresponding probability for the entire network to be rather small ( $P\{C_{e_1}(t) > \alpha\}$  could be as low as  $(0.95)^{30} \approx 0.21$ ). Analysis of this result suggests that lean flow-matching FFN of independent operations are fragile - the output of such networks is vulnerable to even minor upstream disruptions. Mathematically, this follows from the *min*-type form of available effective capacity at point of delivery in Proposition 1, and it could serve as a good explanation for recent catastrophic losses mentioned in Chapter I.

## CHAPTER IV

## EXTENDED ANALYSIS OF FFN

In this chapter we extend the basic analysis of chapter III by relaxing certain structural assumptions of the feed-forward architecture (Section A) and introducing random propagation times (Section B). A special case of FFN called serial FFN (SFFN) is modeled in section C. We study the impact of capacity disruptions and inventory buffers (Section D), and make initial efforts to model random network topology (section E).

*A. Relaxing structural assumptions of FFN*

In this section we relax two structural constraints of FFNs: firstly, that only immediate adjacent tiers can be possibly connected and, secondly, the feed-forwardness constraint that no re-entrant flow is allowed.

FFN assume that within a tier, each vertex is connected only to vertices in the previous tier and vertices in the subsequent tier. Any vertex can feed only vertices in its immediately subjacent tier, that is,  $\forall i \in N_k, j \in N_{k+s}, A_{ji} = 0$ , where  $k = 1, 2, \dots, m; s \geq 2$ . However, not all enterprise level production networks comply with this constraint. We will relax this constraint and allow feed-forward connections among multiple tiers.

Suppose we have a feed-forward flow-matching network, so that there exist directly connected vertices  $i$  and  $j$  separated by several tiers (see Figure 4), i.e.,  $\exists i \in N_k, j \in N_{k+s}, s \geq 2$  s.t.  $A_{ji} > 0$ . For vertex  $i$ , available supply capacity is given by:

$$C_{s_i}(t) = \min_{\substack{l \in N_{k+1} \\ A_{li} > 0}} \{A_{li} C_{e_l}(t), A_{ji} C_{e_j}(t)\}. \quad (4.1)$$

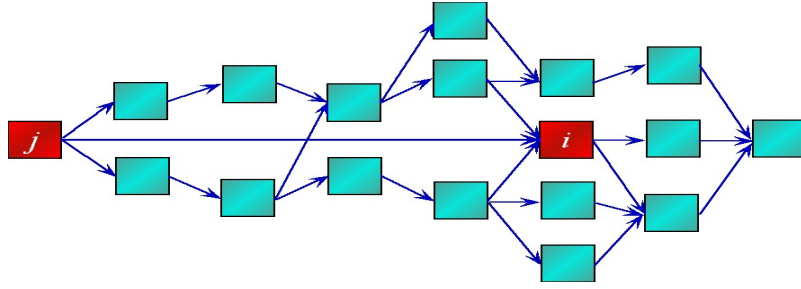

Fig. 4. Modeling a direct multi-tier connection between vertices  $j$  and  $i$ .

It is possible to model such a network and still remain within the bounds of FFN and utilize our capacity calculus results. Consider introducing  $s-1$  dummy vertices located in adjacent tiers in the following way:  $j_1 \in N_{k+s-1}$ ,  $j_2 \in N_{k+s-2}, \dots, j_{s-1} \in N_{k+1}$  (see Figure 5).

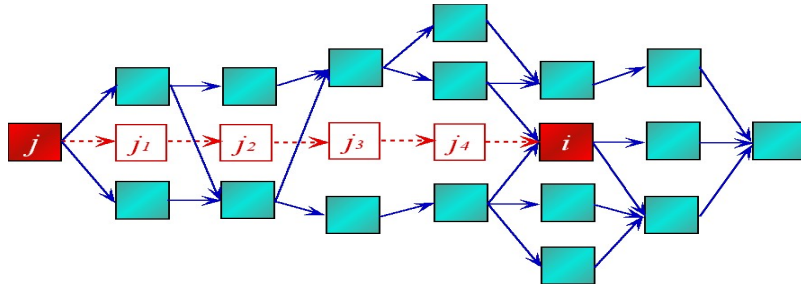

Fig. 5. Introducing dummy vertices.

For these intermediate dummy vertices we assume the following properties:

1.  $C_{e_{j_1}}(t) = C_{e_j}(t)$ .
2.  $C_{e_{j_k}}(t) = C_{s_{j_k}}(t)$ ,  $k = 2, \dots, s-1$ ;  $t > 0$ .
3.  $A_{j j_1} = A_{j i}$ .
4.  $A_{j_k j_{k+1}} = 1$ ,  $\forall k = 1, 2, \dots, s-2$ .
5.  $A_{j_{s-1} i} = 1$ .

6. (3)-(5) implies that  $A_{jj_1}A_{j_1j_2}\dots A_{j_{s-1}i} = A_{ji}$ .

Now we have (4.1) in terms of effective capacities of dummy vertices as follows:

$$\begin{aligned}
C_{s_i}(t) &= \min_{\substack{l \in N_{k+1} \\ A_{li} > 0}} \{A_{li} C_{e_l}(t)\} \\
&= \min_{\substack{l \in N_{k+1} \\ A_{li} > 0}} \{A_{li} C_{e_l}(t), A_{j_{s-1}i} C_{e_{j_{s-1}}}(t)\} \\
&= \min_{\substack{l \in N_{k+1} \\ A_{li} > 0}} \{A_{li} C_{e_l}(t), A_{j_{s-1}i} \min\{C_{p_{j_{s-1}}}(t), C_{s_{j_{s-1}}}(t)\}\} \\
&= \min_{\substack{l \in N_{k+1} \\ A_{li} > 0}} \{A_{li} C_{e_l}(t), A_{j_{s-1}i} A_{j_{s-2}j_{s-1}} C_{e_{j_{s-2}}}(t)\} \\
&= \min_{\substack{l \in N_{k+1} \\ A_{li} > 0}} \{A_{li} C_{e_l}(t), A_{j_{s-1}i} A_{j_{s-2}j_{s-1}} \min\{C_{p_{j_{s-2}}}(t), C_{s_{j_{s-2}}}(t)\}\} \\
&= \min_{\substack{l \in N_{k+1} \\ A_{li} > 0}} \{A_{li} C_{e_l}(t), A_{j_{s-1}i} A_{j_{s-2}j_{s-1}} A_{j_{s-3}j_{s-2}} C_{e_{j_{s-3}}}(t)\} \\
&= \dots \\
&= \min_{\substack{l \in N_{k+1} \\ A_{li} > 0}} \{A_{li} C_{e_l}(t), A_{j_{s-1}i} A_{j_{s-2}j_{s-1}} A_{j_{s-3}j_{s-2}} \dots A_{j_1j_2} C_{e_{j_1}}(t)\} \\
&= \min_{\substack{l \in N_{k+1} \\ A_{li} > 0}} \{A_{li} C_{e_l}(t), A_{j_{s-1}i} A_{j_{s-2}j_{s-1}} A_{j_{s-3}j_{s-2}} \dots A_{j_1j_2} A_{jj_1} C_{e_j}(t)\} \\
&= \min_{\substack{l \in N_{k+1} \\ A_{li} > 0}} \{A_{li} C_{e_l}(t), A_{ji} C_{e_j}(t)\},
\end{aligned}$$

by property 6 for intermediate vertices. The equivalence of these approaches is recognized by considering paths of vertex  $j$ . Introducing supplementary vertices  $j_1 \in N_{k+s-1}$ ,  $j_2 \in N_{k+s-2}, \dots, j_{s-1} \in N_{k+1}$  does not change the corresponding value of  $A_j^s$  for a path  $s$  from node  $j$  through vertex  $i$  to point of delivery, since  $A_{jj_1}A_{j_1j_2}\dots A_{j_{s-1}i} = A_{ji}$ .

Now we turn our attention to the feed-forward constraint. In some cases it may

be desirable to relax this assumption and allow re-entrant flow. There could be a number of reasons for this. One possibility is to model a situation where a part, after being assembled at a tier, does not pass quality control procedure at the next tier, and has to be brought back. Another example would be to model some specialized treatment after which the part has to be brought back to finish manufacturing before shipping to next tier.

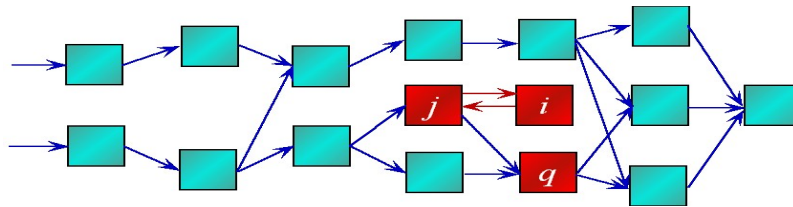

Fig. 6. Modeling re-entrant flow.

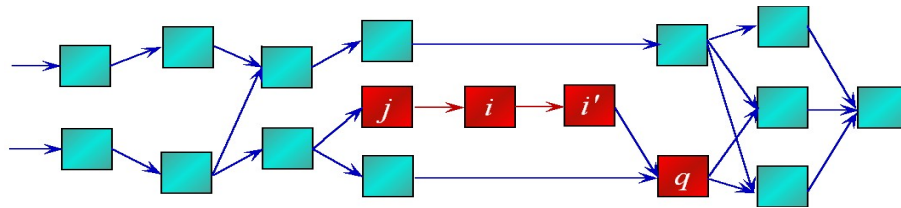

Fig. 7. Reconfiguring the network to eliminate re-entrant flow.

Suppose we have a network with a vertex  $j \in N_k$  sourcing vertex  $i \in N_{k-1}$  with a re-entrant flow from vertex  $i$  to vertex  $j$  ( $A_{ji} = A_{ij} = 1$ ). After parts have been processed for a second time at  $j$ , they go directly to vertex  $q \in N_{k-1}$  (blue arrow on Figure 6) with ( $A_{jq} = 1$ ). Consider reconfiguring the network by introducing an additional vertex  $i'$  (and additional tier) with  $A_{ij} = A_{i'i'}$  so that  $A_{ji} = A_{i'i'} = A_{i'q} = 1$  (see Figure 7).

Now we can model the assembly as a feed-forward network with connections running through multiple tiers. In a similar way we can model feedback of arbitrary complexity (e.g., multi-step feedback, feedback that multifurcate, etc).

In this section we have modeled network models which are more general than FFN. These networks allow direct multi-tier connections and re-entrant flows. At a strategic level, we can view any enterprise as a FFN. At the same time, results developed in this section can be applied to model risk for local subassemblies and individual vertices.

### B. *Modeling propagation times*

In chapter III propagation times between vertices were assumed to be negligible, i.e., a disruption in available effective capacity of a vertex in any tier will have an immediate impact on available effective capacity of all vertices connected to the disrupted vertex downstream the network. In many situations, however, there are positive propagation times between vertices so that disruptions have a delayed impact. Propagation times can include handling time at the point of output vertex, time in transit, handling time at the point of input vertex, delays, etc. Propagation times are generally random. In this section we introduce propagation times between vertices still assuming that the enterprise is running very lean with zero inventories. First, we model deterministic propagation times and later investigate the random case.

We denote a *propagation time* from vertex  $j \in N_{k+1}$  to vertex  $i \in N_k$ ,  $k = 1, 2, \dots, m$  located in adjacent tiers by  $T_{ji} > 0$ . Obviously,  $A_{ji} = 0$  if and only if  $T_{ji} = 0$ . From (3.1) available supply capacity of any vertex  $i \in N_k$  can be expressed

in the following way, including propagation time from node  $j$  to node  $i$ :

$$C_{s_i}(t) = \min_{\substack{j \in N_{k+1} \\ A_{ji} > 0}} \{A_{ji} C_{e_j}(t - T_{ji})\}, \quad (4.2)$$

and its available effective capacity is, therefore, by Lemma 1 is given by

$$C_{e_i}(t) = \min\{C_{p_i}(t), C_{s_i}(t)\} = \min_{\substack{j \in N_{k+1} \\ A_{ji} > 0}} \{C_{p_i}(t), A_{ji} C_{e_j}(t - T_{ji})\}. \quad (4.3)$$

Now we can obtain the following expression for available effective capacity at point of delivery:

**Proposition 4** *Available effective capacity at point of delivery, for fixed  $t \geq 0$ , is given by*

$$C_{e_1}(t) = \min_{\substack{M=2,3,\dots,m \\ i_1 \in N_1, i_2 \in N_2, \dots, i_m \in N_m \\ A_{i_k i_{k-1}} > 0 \forall k=1, \dots, m}} \{C_{p_1}(t), C_{p_{i_M}}(t - \sum_{k=2}^M T_{i_k i_{k-1}}) \prod_{k=2}^M A_{i_k i_{k-1}}\},$$

provided that  $C_{e_i}(t) = C_{p_i}(t) \forall i \in N_m$ .

*Proof.* Similar to the proof of Proposition 1, the inclusion of propagation times gives

$$\begin{aligned} C_{e_1}(t) &= \min\{C_{p_1}(t), C_{s_1}(t)\} \\ &= \min_{h \in N_1, i \in N_2} \{C_{p_h}(t), C_{e_i}(t - T_{ih})\} \\ &= \min_{h \in N_1, i \in N_2} \{C_{p_h}(t), \min_{\substack{j \in N_3 \\ A_{ji} > 0}} \{C_{p_i}(t - T_{ih}), A_{ji} C_{e_j}(t - T_{ih} - T_{ji})\}\} \\ &= \min_{\substack{h \in N_1, i \in N_2, j \in N_3 \\ A_{ji} > 0}} \{C_{p_h}(t), C_{p_i}(t - T_{ih}), A_{ji} C_{e_j}(t - T_{ih} - T_{ji})\} \\ &\dots \\ &= \min_{\substack{M=2,3,\dots,m \\ j_1 \in N_1, j_2 \in N_2, \dots, j_m \in N_m \\ A_{j_k j_{k-1}} > 0 \forall k=1, \dots, m}} \{C_{p_1}(t), C_{p_{j_M}}(t - \sum_{k=2}^M T_{j_k j_{k-1}}) \prod_{k=2}^M A_{j_k j_{k-1}}\}. \end{aligned}$$

■

We can obtain a result equivalent to Proposition 4 by introducing path times. For

each unique path  $i$  from vertex  $j \in N_k$  to point of delivery in the form of (3.3), we let  $T_j^i$  be the *total propagation time of the path*  $L_j^i$ .  $T_j^i$  is the sum of propagation times between individual vertices constituting the path

$$T_j^i = T_{jj_1^i} + T_{j_1^i j_2^i} + \dots + T_{j_{k-2}^i j_1^i}. \quad (4.4)$$

Now let  $\bar{T}_j$  be the total propagation time of the path with the smallest  $A_j^i$ , i.e.,

$$\bar{T}_j = T_j^i \text{ when } i \text{ is such that } A_j^i = \bar{A}_j. \quad (4.5)$$

We denote *the total propagation time of vertex*  $j$  by  $\bar{T}_j$ .

**Proposition 5** *Available effective capacity at point of delivery, for fixed  $t \geq 0$ , is given by*

$$C_{e_1}(t) = \min_{j \in N} \{ \bar{A}_j C_{p_j}(t - \bar{T}_j) \}.$$

The proof is similar to that of Proposition 2 and follows from Proposition 4, (4.4) and (4.5). ■

Finally, we have

**Proposition 6** *The complimentary distribution of available effective capacity of a network, for fixed  $t \geq 0$ , is the product of complimentary distributions of available production capacity of individual vertices*

$$\bar{F}_{C_{e_1}(t)}(\alpha) = P\{C_{e_1}(t) > \alpha\} = \prod_{j=1}^n P\{\bar{A}_j C_{p_j}(t - \bar{T}_j) > \alpha\} = \prod_{j=1}^n \bar{F}_{C_{p_j}(t - \bar{T}_j)}(\alpha / \bar{A}_j).$$

The proof follows from Proposition 3 and Proposition 5.

Now, assume that propagation times  $T_{jh}$  between successive assembly operations at any vertices  $j$  and  $h$  are independent nonnegative random variables with known



distribution functions  $F_{T_{jh}}(t) = P\{T_{jh} \leq t\}$ ,  $h, j = 1, 2, \dots, n$ ;  $t > 0$ . We assume that  $F_{T_{jh}}(t)$  is absolutely continuous with density  $f_{T_{jh}}(t)$ ,  $h, j = 1, 2, \dots, n$ ,  $t > 0$ .

Suppose  $j \in N_k$ , and let the path corresponding to the minimal  $A_j^i$  be of the form of

$$L_j = \{j, j_1 \in N_{k-1}, j_2 \in N_{k-2}, \dots, j_{k-2} \in N_2, 1 \in N_1\}.$$

To find an expression for the distribution of  $\bar{T}_j = T_{jj_1} + T_{j_1j_2} + \dots + T_{j_{k-2}1}$ , observe that

$$P\{T_{jj_1} + T_{j_1j_2} \leq t\} = \int_0^t F_{T_{jj_1}}(t-u) f_{T_{j_1j_2}}(u) du. \quad (4.6)$$

The distribution (4.6) is the convolution of  $F_{T_{jj_1}}(t)$  and  $F_{T_{j_1j_2}}(t)$  and is denoted by  $F_{T_{jj_1}}(t) * F_{T_{j_1j_2}}(t)$ . Then it follows that

$$F_{\bar{T}_j}(t) = F_{T_{jj_1}} * F_{T_{j_1j_2}} * \dots * F_{T_{j_{k-2}1}}(t). \quad (4.7)$$

In particular, if  $F_{T_{jj_1}}(t), F_{T_{j_1j_2}}(t), \dots, F_{T_{j_{k-2}1}}(t)$  are identically distributed with a distribution function  $F(t)$ , we have that

$$F_{\bar{T}_j}(t) = F^{(k-1)}(t),$$

where  $F^{(k-1)}(t)$  is the  $(k-1)$ -fold convolution of  $F$ .

It is possible for a vertex  $j$  to have a non-unique value of  $\bar{A}_j$ , i.e., there may exist two or more paths  $L_j^i$ ,  $i \in \mathbb{N}$  s.t.  $\forall i A_j^i = \bar{A}_j$ , where the corresponding total propagation times of the paths  $T_j^i$  differ. If we take the total propagation time of the vertex to be

$$\bar{T}_j = \min_i \{T_j^i\}, \quad (4.8)$$

Propositions 5 and 6 hold for deterministic case. For random propagation times we

have

$$\bar{F}_{T_j}(t) = P\left\{\min_{i=2,3,\dots,\bar{n}} T_j^i > t\right\} = P\{T_j^1 > t, T_j^2 > t, \dots, T_j^{\bar{n}} > t\}. \quad (4.9)$$

Note that  $T_j^i$  need not to be independent as they could have common arcs. To analyze (4.9) we need an additional terminology.

Consider two propagation times for vertex  $j$ , say  $L_j^1$  and  $L_j^2$ . We say that paths  $L_j^1$  and  $L_j^2$  are *overlapping* if they have at least one common *arc*, and *non-overlapping* otherwise. For example, on Figure 8, purple- and yellow-colored paths are overlapping twice, while green- and yellow-colored paths are non-overlapping. Note that it is possible for two paths to have one or more common vertices and be non-overlapping (e.g. navy- and yellow-colored paths are non-overlapping).

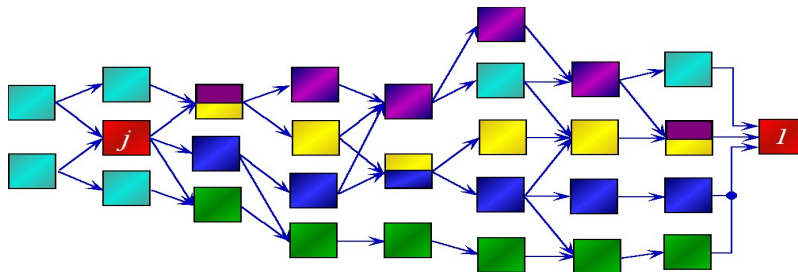

Fig. 8. Overlapping and non-overlapping paths of a vertex.

We analyze (4.9) separately for overlapping and non-overlapping paths. We have the following proposition

**Proposition 7** *The complimentary distribution of the total propagation time of vertex  $j$  for the case of  $\bar{n}$  non-overlapping paths  $T_j^1, T_j^2, \dots, T_j^{\bar{n}}$  is given by*

$$\bar{F}_{T_j}(t) = P\left\{\min_{i=2,3,\dots,\bar{n}} T_j^i > t\right\} = P\{T_j^1 > t\}P\{T_j^2 > t\} \dots P\{T_j^{\bar{n}} > t\}.$$

*Proof.* We first model the case of two non-overlapping paths and later extend it.

Consider two non-overlapping paths  $L_j^1$  and  $L_j^2$  of vertex  $j$ . Let the total propagation times of the paths be  $T_j^1$  and  $T_j^2$  respectively:

$$\begin{aligned} T_j^1 &= T_{jj_1^1} + T_{j_1^1 j_2^1} + \dots + T_{j_{k-2}^1 j_1^1} \\ T_j^2 &= T_{jj_1^2} + T_{j_1^2 j_2^2} + \dots + T_{j_{k-2}^2 j_1^2}. \end{aligned}$$

Since  $T_j^1$  is a function of only  $T_{jj_1^1}$ ,  $T_{j_1^1 j_2^1}$ , ...  $T_{j_{k-2}^1 j_1^1}$  and  $T_j^2$  is a function of only  $T_{jj_1^2}$ ,  $T_{j_1^2 j_2^2}$ , ...  $T_{j_{k-2}^2 j_1^2}$ , and all individual propagation times are independent, it follows that the random variables  $T_j^1$  and  $T_j^2$  are independent. So we have

$$P\{\min\{T_j^1, T_j^2\} > t\} = P\{T_j^1 > t, T_j^2 > t\} = P\{T_j^1 > t\}P\{T_j^2 > t\}. \quad (4.10)$$

When we have more than two non-unique total propagation times of vertex  $j$  associated with paths  $L_j^i$ ,  $i = 2, 3, \dots, \bar{n}$ , the analysis is similar:

$$\begin{aligned} P\{\min_{i=2,3,\dots,\bar{n}} T_j^i > t\} &= P\{T_j^1 > t, T_j^2 > t, \dots, T_j^{\bar{n}} > t\} \\ &= P\{T_j^1 > t\}P\{T_j^2 > t\} \dots P\{T_j^{\bar{n}} > t\}. \end{aligned}$$

■

Now we model overlapping paths.

**Proposition 8** *The distribution of the total propagation time of vertex  $j$  for the case of two paths  $T_j^1$  and  $T_j^2$ , which overlap through one common arc, connecting vertices  $j \in N_k$  and  $j_1^1 \in N_{k-1}$ , is given by*

$$P\{\bar{T}_j \leq t\} = P\{\min\{T_j^1, T_j^2\} \leq t\} = F_{T_{jj_1^1}} * (1 - \bar{F}_Z)(t),$$

where

$$\bar{F}_Z(t) = (1 - F_{T_{j_1^1 j_2^1}} * \dots * F_{T_{j_{k-2}^1 j_1^1}}(t)) (1 - F_{T_{j_1^2 j_2^2}} * \dots * F_{T_{j_{k-2}^2 j_1^2}}(t)).$$

*Proof.* We assume, without loss of generality, that this common arc connects vertices  $j \in N_k$  and  $j_1^1 \in N_{k-1}$ . After  $j_1^1$  the paths split and do not intersect. Let the total propagation times of the paths be  $T_j^1$  and  $T_j^2$  respectively

$$\begin{aligned} T_j^1 &= T_{jj_1^1} + T_{j_1^1 j_2^1} + \dots + T_{j_{k-2}^1 1} \\ T_j^2 &= T_{jj_1^1} + T_{j_1^1 j_2^2} + \dots + T_{j_{k-2}^2 1}. \end{aligned}$$

We seek the distribution of  $\min\{T_j^1, T_j^2\}$ . Now,  $T_j^1$  and  $T_j^2$  are both functions of  $T_{jj_1^1}$ , and, thus, not independent. For the case of two overlapping paths with one common arc, let  $Z$  be defined as

$$Z = \min\{T_{j_1^1 j_2^1} + \dots + T_{j_{k-2}^1 1}, T_{j_1^1 j_2^2} + \dots + T_{j_{k-2}^2 1}\}.$$

Then

$$\min\{T_j^1, T_j^2\} = T_{jj_1^1} + Z.$$

Now, since  $T_{j_1^1 j_2^1} + \dots + T_{j_{k-2}^1 1}$  is a function of only  $T_{j_1^1 j_2^1}, \dots, T_{j_{k-2}^1 1}$ , and  $T_{j_1^1 j_2^2} + \dots + T_{j_{k-2}^2 1}$  is a function of only  $T_{j_1^1 j_2^2}, \dots, T_{j_{k-2}^2 1}$ , it follows that these sums of independent random variables are independent, and so we have that

$$\begin{aligned} \bar{F}_Z(t) &= P\{\min\{T_{j_1^1 j_2^1} + \dots + T_{j_{k-2}^1 1}, T_{j_1^1 j_2^2} + \dots + T_{j_{k-2}^2 1}\} > t\} \\ &= P\{T_{j_1^1 j_2^1} + \dots + T_{j_{k-2}^1 1} > t, T_{j_1^1 j_2^2} + \dots + T_{j_{k-2}^2 1} > t\} \\ &= P\{T_{j_1^1 j_2^1} + \dots + T_{j_{k-2}^1 1} > t\} P\{T_{j_1^1 j_2^2} + \dots + T_{j_{k-2}^2 1} > t\} \\ &= (1 - F_{T_{j_1^1 j_2^1}} * \dots * F_{T_{j_{k-2}^1 1}}(t)) (1 - F_{T_{j_1^1 j_2^2}} * \dots * F_{T_{j_{k-2}^2 1}}(t)). \end{aligned}$$

Note that  $Z$  and  $T_{jj_1^1}$  are independent. Finally

$$P\{\min\{T_j^1, T_j^2\} \leq t\} = P\{T_{jj_1^1} + Z \leq t\} = F_{T_{jj_1^1}} * (1 - \bar{F}_Z)(t). \quad (4.11)$$

■

It is straightforward to extend this approach to include multiple common arcs. Suppose that we have two paths  $L_j^1$  and  $L_j^2$  of vertex  $j \in N_k$  which overlap through an arbitrary number  $q$  of common arcs located in an arbitrary manner. We simplify the notation by letting  $X_1, X_2, \dots, X_q$  denote the propagation times associated with the common arcs. Let  $F_{X_1}(t), F_{X_2}(t), \dots, F_{X_q}(t)$  be the respective distributions of  $X_1, X_2, \dots, X_q$ . After regrouping and renaming,  $T_j^1$  and  $T_j^2$  can be expressed as follows

$$\begin{aligned} T_j^1 &= X_1 + X_2 + \dots + X_q + T_{j_q^1 j_{q+1}^1} + \dots + T_{j_{k-2}^1} \\ T_j^2 &= X_1 + X_2 + \dots + X_q + T_{j_q^2 j_{q+1}^2} + \dots + T_{j_{k-2}^2}. \end{aligned}$$

We introduce the following proposition

**Proposition 9** *The distribution of the total propagation time of vertex  $j$ , for the case of two paths  $T_j^1$  and  $T_j^2$  overlapping through  $q$  common arcs, is given by the following expression*

$$\bar{F}_{T_j}(t) = F_{X_1} * F_{X_2} * \dots * F_{X_q} * (1 - \bar{F}_Z)(t),$$

where

$$\bar{F}_Z(t) = (1 - F_{T_{j_q^1 j_{q+1}^1}} * \dots * F_{T_{j_{k-2}^1}}(t)) (1 - F_{T_{j_q^2 j_{q+1}^2}} * \dots * F_{T_{j_{k-2}^2}}(t)).$$

*Proof.* Now we define  $Z$  as

$$Z = \min\{T_{j_q^1 j_{q+1}^1} + \dots + T_{j_{k-2}^1}, T_{j_q^2 j_{q+1}^2} + \dots + T_{j_{k-2}^2}\},$$

so that

$$\min\{T_j^1, T_j^2\} = X_1 + X_2 + \dots + X_q + Z.$$

We have

$$\bar{F}_Z(t) = (1 - F_{T_{j_q^1 j_{q+1}^1}} * \dots * F_{T_{j_{k-2}^1}}(t)) (1 - F_{T_{j_q^2 j_{q+1}^2}} * \dots * F_{T_{j_{k-2}^2}}(t)).$$

Note that  $Z$  and  $X$ s are mutually independent, and finally,

$$P\{\min\{T_j^1, T_j^2\} \leq t\} = P\{\sum_{i=1}^q X_i + Z \leq t\} = F_{X_1} * F_{X_2} * \dots * F_{X_q} * (1 - \bar{F}_Z)(t).$$

■

Note that in the case of multiple overlapping paths  $L_j^i$ ,  $i = 2, 3, \dots, \bar{n}$ , if some or all  $L_j^i$  are overlapping, one can proceed iteratively, by their pairwise comparison:

$$\min_{i=2,3,\dots,\bar{n}} \{T_j^i\} = \min\{T_j^{\bar{n}}, \dots, \min\{T_j^3, \min\{T_j^1, T_j^2\}\}\}.$$

In this section we have modeled random propagation times between vertices. For each vertex  $j$ , potentially having multiple overlapping paths to point of delivery, we have identified the total propagation time,  $\bar{T}_j$ , as a unique measure of propagation delay between the vertex and point of delivery. We have derived the distribution of  $\bar{T}_j$ , which can easily be integrated with the basic underlying model to obtain the distribution of available effective capacity of the network.

This analysis allows to obtain a more precise snapshot of the network which now can include analysis of the impact of upstream disruption delays and in-transit inventory. This is particularly important for global enterprises where propagation times can be of the magnitude of several weeks or months.

The ability to model random propagation times combined with modeling inventory buffers in section D, results in a more efficient handling of capacity disruptions. In this light, development of tools based on intelligent data mining to monitor and manage a real-time dashboard of disruptions/inventory levels for the scale of the enterprise is of a paramount importance. These developments is a subject of future research.

C. *Special case: Serial FFN*

A special type of FFN with a property that each tier consists of only one vertex can be of practical interest (see Figure 9). We shall call such networks *serial FFN* (SFFN).



Fig. 9. A serial feed-forward network.

For SFFN we have that the number of tiers is equal to the number of vertices,  $m = n$ , and according to the numbering scheme,  $j \in N_j \ \forall j = 1, 2, \dots, n$ . Some of the basic properties of FFN will become more specific for SFFN:

**Property 1.**  $N_1 = \{1\}, N_2 = \{2\}, \dots, N_m = N_n = \{n\}$ .

**Properties 2-5.** These properties simplify to the following:  $\forall i, j \in N, A_{ji} > 0 \Leftrightarrow j = i + 1$  and  $A_{ji} > 0 \Rightarrow A_{ji} = 1$ .

Available supply capacity of any vertex  $i \in N$  is expressed as:

$$C_{s_i}(t) = \min_{\substack{j \in N_{i+1} \\ A_{ji} > 0}} \{A_{ji} C_{e_j}(t)\} = C_{e_{i+1}}(t).$$

**Corollary 1** For SFFN, available effective capacity of vertex  $i$ , for a fixed time  $t \geq 0$ , is given by

$$C_{e_i}(t) = \min\{C_{p_i}(t), C_{e_{i+1}}(t)\}.$$

*Proof.*

$$C_{e_i}(t) \stackrel{\text{def}}{=} \min\{C_{p_i}(t), C_{s_i}(t)\} = \min\{C_{p_i}(t), C_{e_{i+1}}(t)\}.$$

■

**Corollary 2** *For SFFN, available effective capacity at point of delivery, for a fixed time  $t \geq 0$ , is given by*

$$C_{e_1}(t) = \min_{j \in N} \{C_{p_j}(t)\}.$$

*Proof.* From Proposition 1 we have that

$$C_{e_j}(t) = \min_{\substack{M=2,3,\dots,m \\ i_1 \in N_1, i_2 \in N_2, \dots, i_m \in N_m \\ A_{i_k i_{k-1}} > 0 \forall k=1, \dots, m}} \{C_{p_1}(t), C_{p_{i_M}}(t) \prod_{k=2}^M A_{i_k i_{k-1}}\}.$$

By properties 2-5 of SFFN, for  $i_1 \in N_1, i_2 \in N_2, \dots, i_m \in N_m$  and  $M = 2, 3, \dots, m$ , we have that

$$\prod_{k=2}^M A_{i_k i_{k-1}} = 1,$$

which along with property 1 for SFFN give the desired result.

As an alternative proof, consider paths of vertex  $j$ . For each vertex  $j \in N_j$ , there exists only one path from the vertex to point of delivery:

$$L_j^1 = \{j, j-1 \in N_{j-1}, j-2 \in N_{j-2}, \dots, 1 \in N_1\}.$$

The product of the corresponding multifurcation coefficients is given by:

$$A_j^1 = A_{j(j-1)} A_{(j-1)(j-2)} \dots A_{21} = 1,$$

and

$$\bar{A}_j \stackrel{\text{def}}{=} \min_i \{A_j^i\} = A_j^1 = 1.$$

Now the result follows from Proposition 2 and the fact that  $\bar{A}_j = 1 \forall j \in N$ . ■

**Corollary 3** *For SFFN, the complimentary distribution of available effective capacity of a network, for fixed  $t \geq 0$ , is the product of complimentary distributions of available*



*production capacity of individual vertices*

$$\bar{F}_{C_{e_1}(t)}(\alpha) = P\{C_{e_1}(t) > \alpha\} = \prod_{j=1}^n \bar{F}_{C_{p_j}(t)}(\alpha), \quad \alpha \geq 0.$$

The proof follows immediately from Proposition 3. ■

Introducing propagation times between vertices, available supply capacity of any vertex  $i \in N$  can be expressed as

$$C_{s_i}(t) = \min_{\substack{j \in N_{i+1} \\ A_{ji} > 0}} \{A_{ji} C_{e_j}(t - T_{ji})\} = C_{e_{i+1}}(t - T_{(i+1)i}),$$

and available effective capacity of the vertex is given by

$$C_{e_i}(t) = \min\{C_{p_i}(t), C_{e_{i+1}}(t - T_{(i+1)i})\}.$$

**Corollary 4** *For SFFN, available effective capacity at point of delivery, for a fixed time  $t \geq 0$  and random propagation times, is given by*

$$C_{e_1}(t) = \min_{j=2,3,\dots,n} \{C_{p_1}(t), C_{p_j}(t - \sum_{k=2}^j T_{k(k-1)})\},$$

*provided that  $C_{e_n}(t) = C_{p_n}(t)$ .*

*Proof.* Note that

$$\begin{aligned} C_{e_1}(t) &= \min\{C_{p_1}(t), C_{s_1}(t)\} \\ &= \min\{C_{p_1}(t), C_{e_2}(t - T_{21})\} \\ &= \min\{C_{p_1}(t), \min\{C_{p_2}(t - T_{21}), C_{e_3}((t - T_{21}) - T_{32})\}\} \\ &= \min\{C_{p_1}(t), C_{p_2}(t - T_{21}), C_{e_3}(t - (T_{21} + T_{32}))\} \\ &= \dots \\ &= \min_{j=2,3,\dots,n} \{C_{p_1}(t), C_{p_j}(t - \sum_{k=2}^j T_{k(k-1)})\}. \end{aligned}$$

As an alternative proof, in terms of propagation times of paths, we have

$$T_j^1 = T_{j(j-1)} + T_{(j-1)(j-2)} + \dots + T_{21} = \sum_{k=2}^j T_{k(k-1)},$$

and

$$\bar{T}_j = T_j^1 = \sum_{k=2}^j T_{k(k-1)}.$$

From Proposition 4 we have

$$\begin{aligned} C_{e_1}(t) &= \min_{j \in N} \{\bar{A}_j C_{p_j}(t - \bar{T}_j)\} = \min_{j \in N \setminus N_1} \{C_{p_1}(t), \bar{A}_j C_{p_j}(t - \bar{T}_j)\} \\ &= \min_{j=2,3,\dots,n} \{C_{p_1}(t), C_{p_j}(t - \sum_{k=2}^j T_{k(k-1)})\}. \end{aligned}$$

■

Finally, for

$$L_j = \{j \in N_j, j-1 \in N_{j-1}, j-2 \in N_{j-2}, \dots, 1 \in N_1\},$$

we have that the distribution of

$$\bar{T}_j = T_{j(j-1)} + T_{(j-1)(j-2)} + \dots + T_{21}$$

is given by

$$F_{\bar{T}_j}(t) = F_{T_{j(j-1)}}(t) * F_{T_{(j-1)(j-2)}}(t) * \dots * F_{T_{21}}(t).$$

Analyzing Proposition 3 and Corollary 3 we can conclude that SFFN give extreme case results that might be used as quick-reference, lower bounds for more general networks. For the example on page 18, for  $n = 30$ , and probabilities of exceeding a certain capacity level for individual vertices  $P\{C_{p_j}(t) > \alpha\} = 0.95$ , we have the corresponding probability for the entire network  $P\{C_{e_1}(t) > \alpha\} \approx 0.21$ .

D. *Modeling the impact of inventory buffers*

In this section we consider the impact of disruptions on available effective capacity of the entire network and individual vertices. We introduce inventory buffers and investigate the influence of propagation times under capacity disruptions.

Suppose that a disruptive event reduces available production capacity of vertex  $i \in N_k, C_{p_i}$ , by  $\Delta C_{p_i} > 0$  for a period of time  $\Delta t_i > 0$  beginning at  $t$ . Impact of this event on the available effective capacity at the point of delivery will depend on the state of the network at time  $t$ . We consider two possible states of the network: flow balanced and flow unbalanced. In a flow balanced network, each vertex has available production capacity matching available supply capacities of vertex's suppliers, i.e., the following holds for any fixed vertex  $i \in N_k, k = 1, 2, \dots, m$  and for any supplier of the vertex  $j_n \in N_{k+1}$  (see Figure 10):

$$A_{j_1 i} C_{e_{j_1}} = A_{j_2 i} C_{e_{j_2}} = A_{j_3 i} C_{e_{j_3}} = \dots = A_{j_n i} C_{e_{j_n}} = \sum_{s \in N_{k-1}} A_{is} C_{e_i}. \quad (4.12)$$

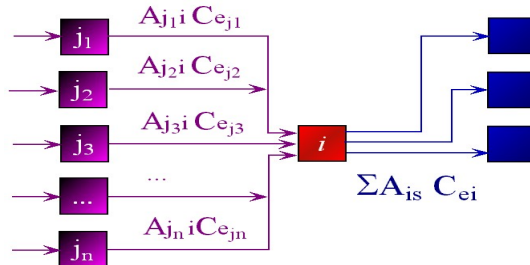

Fig. 10. Modeling a flow balanced network.

If the network is flow balanced, and a vertex  $i \in N_k, k = 1, 2, \dots, m$  has tier-1 suppliers as vertices  $j_n \in N_{k+1}, n = 1, 2, \dots$ , then from (4.12) and (3.1) we have the

following:

$$C_{s_i}(t) = \min_{\substack{n=1,2,\dots \\ A_{j_n i} > 0}} \{A_{j_n i} C_{e_{j_n}}(t)\} = A_{j_1 i} C_{e_{j_1}}(t), \quad (4.13)$$

without loss of generality, so that by definition of a flow balanced network and from (4.13) we obtain

$$C_{e_i}(t) = C_{p_i}(t) = C_{s_i}(t) = A_{j_1 i} C_{e_{j_1}}(t). \quad (4.14)$$

If we now apply the same logic to vertex  $j_1 \in N_{k+1}$  and consider its suppliers, we obtain for some  $k_1 \in N_{k+2}$  (see Figure 11) from (4.13) and (4.14):

$$\begin{aligned} C_{s_{j_1}}(t) &= A_{k_1 j_1} C_{e_{k_1}}(t), \\ C_{e_{j_1}}(t) &= C_{s_{j_1}}(t) = A_{k_1 j_1} C_{e_{k_1}}(t), \\ C_{e_i}(t) &= A_{j_1 i} C_{e_{j_1}}(t) = A_{j_1 i} A_{k_1 j_1} C_{e_{k_1}}(t) = A_{j_1 i} A_{k_1 j_1} A_{l_1 k_1} C_{e_{l_1}}(t), \end{aligned}$$

for some  $l_1 \in N_{k+3}$  (see Figure 11). In general, by continuing in this fashion, we can identify  $m$  vertices located in adjacent tiers,  $i_s \in N_s$ ,  $s = 1, 2, \dots, m$ , so that applying results for serial networks from the previous section, we get the following for the available effective capacity at point of delivery:

$$C_{e_1}(t) = \bar{A}_{i_1} C_{p_{i_1}}(t - \bar{T}_{i_1}) = \bar{A}_{i_2} C_{p_{i_2}}(t - \bar{T}_{i_2}) = \dots = \bar{A}_{i_m} C_{p_{i_m}}(t - \bar{T}_{i_m}). \quad (4.15)$$

Now, suppose that at time  $t$ , a disruption reduces available production capacity of fixed vertex  $i \in N_k$  by  $\Delta C_{p_i} > 0$  for a period of time  $\Delta t_i > 0$ , and then instantly recovers. After possible renumbering of vertices, using (4.15) we can deduce that available effective capacity at point of delivery will be reduced by  $\bar{A}_i \Delta C_{p_i}$  in the interval  $[t + \bar{T}_i, t + \bar{T}_i + \Delta t_i]$ , provided that no other disruptions occur downstream the network between  $t$  and  $t + \bar{T}_i$ .

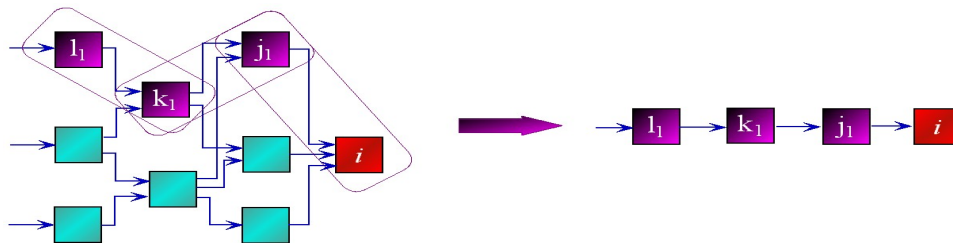

Fig. 11. Conversion from a flow balanced network to a serial network.

To conclude this part, we want to note that, in practice, most enterprise networks are designed as flow balanced, especially for cases where supply is inexpensive comparing to the value of capital assets. Analysis of flow unbalanced networks and effect of contemporaneous disruptions can be very complicated, and it is a subject of future research.

We are now ready to investigate the effects of inventory buffers. Consider vertex  $i \in N_k$ ,  $k = 1, 2, \dots, m$ , and suppose it has multiple tier-1 suppliers  $j_1, j_2, j_3, \dots \in N_{k+1}$  operating in a flow balanced network (see Figure 12).

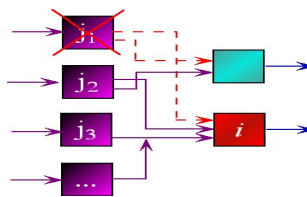

Fig. 12. Tier-1 suppliers of vertex  $i$ .

Suppose, at time  $t$ , a disruption reduces available effective capacity of vertex  $j_1$  (see Figure 12) by  $\Delta C_{e_{j_1}} > 0$  for a period  $\Delta t > 0$ , and then instantly recovers (see

Figure 13(a)). We have that

$$C_{e_{j_1}}(t) = C_{e_{j_1}}(t - \epsilon) - \Delta C_{e_{j_1}} \text{ for an arbitrary small } \epsilon > 0,$$

$$C_{e_{j_1}}(t + s) = C_{e_{j_1}}(t) \text{ for } s < \Delta t, \text{ and}$$

$$C_{e_{j_1}}(t + \Delta t) = C_{e_{j_1}}(t - \epsilon).$$

The disruption could be a disruption in production  $C_{p_{j_1}}$  and/or supply capacity  $C_{s_{j_1}}$  as well as a temporary inability to move parts from  $j_1$  to  $i$ . Available effective capacities of vertices  $j_2, j_3, \dots$ , as well as available production capacity of vertex  $i$  continue to stay the same.

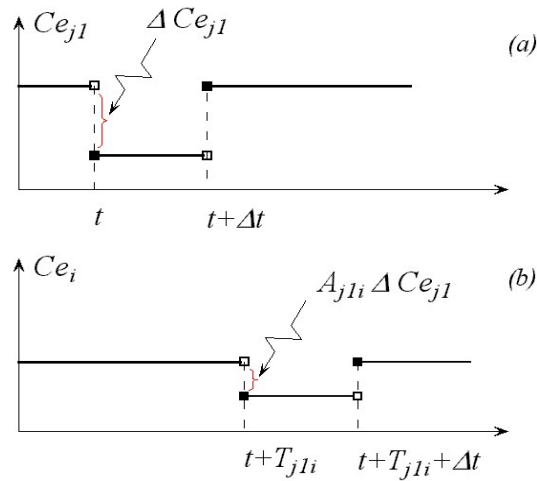

Fig. 13. Impact of disruptions and inventory buffers.

In general, we have

$$C_{s_i}(t) \stackrel{\text{def}}{=} \min\{A_{j_1 i} C_{e_{j_1}}(t - T_{j_1 i}), A_{j_2 i} C_{e_{j_2}}(t - T_{j_2 i}), A_{j_3 i} C_{e_{j_3}}(t - T_{j_3 i}), \dots\},$$

so that we have

$$C_{s_i}(t + T_{j_1 i}) < C_{p_i}(t + T_{j_1 i}), \text{ and}$$

$$C_{e_i}(t + T_{j_1 i}) = C_{s_i}(t + T_{j_1 i}) = A_{j_1 i} \bar{C}_{e_{j_1}}(t) = A_{j_1 i} [C_{e_{j_1}}(t - \epsilon) - \Delta C_{e_{j_1}}].$$

Therefore, in the presence of zero inventory buffers, we have that available effective capacity of vertex  $i$  will be reduced by  $A_{j_1 i} \Delta C_{e_{j_1}}$  in the interval  $[t + T_{j_1 i}, t + T_{j_1 i} + \Delta t]$  (see Figure 13(b)). Available effective capacity at point of delivery will be reduced by  $\bar{A}_i A_{j_1 i} \Delta C_{e_{j_1}}$ , beginning at  $t + T_{j_1 i} + \bar{T}_i$ , for a period  $\Delta t$ , provided that no other disruptions occur downstream the network between time  $t$  and  $t + T_{j_1 i} + \bar{T}_i$ .

Next we introduce inventory buffers. Suppose that at time  $t > 0$ , vertex  $i$  has inventory buffers  $B_{j_1}^i(t) > 0, B_{j_2}^i(t) > 0, B_{j_3}^i(t) > 0, \dots$  of parts supplied by vertices  $j_1, j_2, j_3, \dots$  respectively. Inventory buffers have the same units as available capacities. Inventory buffer of the disrupted network,  $B_{j_1}^i(t)$ , remains constant until time  $t + T_{j_1 i}$ . When the  $\Delta C_{e_{j_1}}$  disturbance impacts vertex  $i$  at time  $t + T_{j_1 i}$ ,  $B_{j_1}^i(t)$  will start to be depleted at a constant rate  $A_{j_1 i} \Delta C_{e_{j_1}}$  units per unit time. We introduce the following variable

$$t^* = \frac{B_{j_1}^i(t + T_{j_1 i})}{A_{j_1 i} \Delta C_{e_{j_1}}}. \quad (4.16)$$

Then either of the following two cases can happen:

**Case 1.**  $t^* \leq \Delta t$

- 1.1. Buffer  $B_{j_1}^i$  is completely depleted:  $B_{j_1}^i(t + T_{j_1 i} + \Delta t) = 0$ .
- 1.2.  $C_{e_1}$  is reduced by  $\bar{A}_i A_{j_1 i} \Delta C_{e_{j_1}}$  from time  $t + T_{j_1 i} + t^* + \bar{T}_i$  for a period  $\Delta t - t^*$ .
- 1.3. Levels of  $B_{j_2}^i(t), B_{j_3}^i(t), \dots$  are increased by  $A_{j_1 i} \Delta C_{e_{j_1}} (\Delta t - t^*)$ .

**Case 2.**  $t^* > \Delta t$

- 2.1.  $C_{e_1}$  remains unaffected between  $t$  and  $t + T_{j_1 i} + \Delta t + \bar{T}_i$ .
- 2.2. Buffer  $B_{j_1}^i$  is depleted to  $B_{j_1}^i(t + T_{j_1 i} + \Delta t) = B_{j_1}^i(t + T_{j_1 i}) - A_{j_1 i} \Delta C_{e_{j_1}} \Delta t$ .

2.3. Buffers  $B_{j_2}^i(t), B_{j_3}^i(t), \dots$  are unaffected.

Therefore, in the presence of an inventory buffer  $B_{j_1}^i > 0$ , the impact of a disruption can either be eliminated completely, or the total propagation time (delay) of the disruption can be increased from  $(t + T_{j_1 i} + \bar{T}_i)$  to  $(t + T_{j_1 i} + \bar{T}_i + B_{j_1}^i(t + T_{j_1 i}) / A_{j_1 i} \Delta C_{e_{j_1}})$ .

Now suppose that again a disruption reduces available effective capacity of vertex  $j_1$  by  $\Delta C_{e_{j_1}} > 0$ , beginning at time  $t$  for a period  $\Delta t > 0$ , but unlike the previous case, capacity recovers gracefully at rate  $\alpha$  units per unit time (see Figure 14(a)) so that total recovery time  $t_r$  is:

$$t_r = \frac{\Delta C_{e_{j_1}}}{\alpha}, \text{ and}$$

$$C_{e_{j_1}}(t) = C_{e_{j_1}}(t - \epsilon) - \Delta C_{e_{j_1}}, \text{ for an arbitrary small } \epsilon > 0,$$

$$C_{e_{j_1}}(t + s) = C_{e_{j_1}}(t) \text{ for } 0 \leq s < \Delta t,$$

$$C_{e_{j_1}}(t + \Delta t + s) = C_{e_{j_1}}(t + \Delta t) + \alpha s \text{ for } 0 \leq s \leq t_r \text{ (see Figure 14(a)).}$$

In the presence of zero inventory we have

$$C_{e_i}(t + T_{j_1 i} + s) = A_{j_1 i} [C_{e_{j_1}}(t - \epsilon) - \Delta C_{e_{j_1}}] \text{ for } 0 \leq s \leq t,$$

so that beginning at time  $t + T_{j_1 i}$ , available effective capacity of vertex  $i$  will be reduced by  $A_{j_1 i} \Delta C_{e_{j_1}}$  for a period  $\Delta t$  (see Figure 14(b)). Starting at  $t + T_{j_1 i} + \Delta t$ ,  $C_{e_i}$  will recover at rate  $A_{j_1 i} \alpha$ :

$$C_{e_i}(t + T_{j_1 i} + \Delta t + s) = C_{e_i}(t + T_{j_1 i} + \Delta t) + A_{j_1 i} \alpha s \text{ for } 0 \leq s \leq t_r.$$

Available effective capacity at point of delivery will be reduced by  $\bar{A}_i A_{j_1 i} \Delta C_{e_{j_1}}$  beginning at  $t + T_{j_1 i} + \bar{T}_i$ , for a period  $\Delta t$ , provided that no other disruptions occur downstream in the interval  $[t, t + T_{j_1 i} + \bar{T}_i]$ . Starting at time  $t + T_{j_1 i} + \Delta t + \bar{T}_i$ , ca-



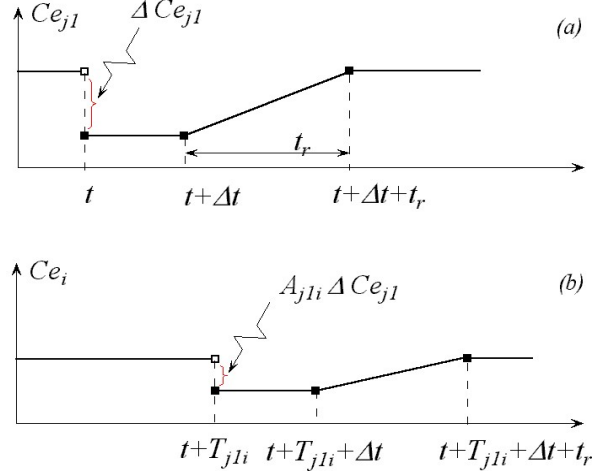

Fig. 14. Impact of disruptions: case of graceful capacity recovery.

capacity will recover at rate  $\bar{A}_i A_{j1i} \alpha$  until complete recovery at time  $t + T_{j1i} + \Delta t + \bar{T}_i + t_r$ .

Now suppose that at time  $t > 0$ , vertex  $i$  has inventory buffers  $B_{j1}^i(t) > 0$ ,  $B_{j2}^i(t) > 0$ ,  $B_{j3}^i(t) > 0, \dots$ . In the presence of the disruption, buffer  $B_{j1}^i(t)$  remains constant until time  $t + T_{j1i}$ . Between  $t + T_{j1i}$  and  $t + T_{j1i} + \Delta t$  it will be depleting at rate  $A_{j1i} \Delta C_{e_{j1}}$ . We introduce the following variable:

$$t^{**} = s \text{ such that } [B_{j1}^i(t + T_{j1i} + \Delta t) - \sum_{k=1}^s A_{j1i}(\Delta C_{e_{j1}} - \alpha k)] \geq 0. \quad (4.17)$$

Here,  $t^{**}$  is the time that the buffer  $B_{j1}^i$  can withstand the disruption to maintain the network flow balance. We have the following cases:

**Case 1.**  $t^* \leq \Delta t$

1.1. The network remains flow balanced in the interval  $[t, t + T_{j1i} + t^* + \bar{T}_i]$ .

Buffer  $B_{j1}^i$  is completely depleted:  $B_{j1}^i(t + T_{j1i} + \Delta t) = B_{j1}^i(t + T_{j1i} + t^*) = 0$ .

1.2.  $C_{e_1}$  is reduced by  $\bar{A}_i A_{j1i} \Delta C_{e_{j1}}$  from time  $t + T_{j1i} + t^* + \bar{T}_i$  for a period  $\Delta t - t^*$ .

Capacity recovers at rate  $\bar{A}_i A_{j_1 i} \alpha$  from time  $t + T_{j_1 i} + \Delta t + \bar{T}_i$ .

- 1.3. Inventory levels  $B_{j_2}^i(t), B_{j_3}^i(t), \dots$  are increased by  $A_{j_1 i} \Delta C_{e_{j_1}} (\Delta t - t^*)$  by time  $t + T_{j_1 i} + \Delta t$ . Starting at  $t + T_{j_1 i} + \Delta t$ , inventory is accumulating at rate  $A_{j_1 i} \alpha$ .

**Case 2.**  $\Delta t < t^* \leq \Delta t + t_r$

- 2.1.  $C_{e_1}$  remains unaffected in the interval  $[t, t + T_{j_1 i} + \Delta t + \bar{T}_i]$ .
- 2.2. By time  $t + T_{j_1 i} + \Delta t$ , buffer  $B_{j_1}^i$  is depleted to the level  

$$B_{j_1}^i(t + T_{j_1 i} + \Delta t) = B_{j_1}^i(t + T_{j_1 i}) - A_{j_1 i} \Delta C_{e_{j_1}} \Delta t.$$
- 2.3. Buffers  $B_{j_2}^i(t), B_{j_3}^i(t), \dots$  are unaffected in the interval  $[t + T_{j_1 i}, t + T_{j_1 i} + \Delta t]$ .
- 2.4. *If  $t^{**} \geq t_r$ , then*

2.4.1.  $C_{e_1}$  remains unaffected.

2.4.2.  $B_{j_1}^i(t + T_{j_1 i} + \Delta t + t_r) = B_{j_1}^i(t + T_{j_1 i} + \Delta t) - \sum_{k=1}^{t_r} A_{j_1 i} (\Delta C_{e_{j_1}} - \alpha k).$

2.4.3. Buffers  $B_{j_2}^i(t), B_{j_3}^i(t), \dots$  are unaffected in  $[t + T_{j_1 i}, t + T_{j_1 i} + \Delta t + t_r]$ .

*If  $t^{**} < t_r$ , then*

2.4.4.  $C_{e_1}$  is unaffected in  $[t + T_{j_1 i} + \Delta t + \bar{T}_i, t + T_{j_1 i} + \Delta t + t^{**} + \bar{T}_i]$ .

2.4.5.  $B_{j_1}^i(t + T_{j_1 i} + \Delta t + t_r) = 0.$

2.4.6.  $C_{e_1}$  recovers at rate  $\bar{A}_i A_{j_1 i} \alpha$  beginning at time  $t + T_{j_1 i} + \Delta t + t^{**} + \bar{T}_i$ .

**Case 3.**  $t^* > \Delta t + t_r$

Apply the results of 2.4.1. - 2.4.3.

In this section we have measured the impact of inventory buffers on total propagation time (delay) of upstream capacity disruptions and available effective capacity of the network. In the presence of an inventory buffer, the impact of a disruption can either be eliminated completely, or the total propagation time (delay) of the disruption can be increased. The amount of increase depends on the magnitude and duration of capacity disruption, as well as on the level of the buffer.

We have considered a one time disruption affecting a single vertex in a flow balanced network. Analysis of flow unbalanced networks and effect of contemporaneous disruptions can be very complicated, and it is a subject of future research.

On a more general note, we want to mention that companies have begun to measure/estimate on-hand inventory in terms of time until days out once a disruption has occurred, but it is difficult to monitor and manage a real-time dashboard of critical inventory levels for the scale of a large enterprise. The inventory measurement in terms of time is at a stage of infancy and more research is required to integrate decision support systems and inventory management.

#### *E. Modeling random network topology*

In a dynamic manufacturing environment, it is often a formidable task to identify the chain of upstream suppliers, especially suppliers which are external to the enterprise. Decision makers must rely on probabilistic models. As we traverse the network from the final point of delivery upstream, our knowledge of configuration of suppliers becomes less certain. Hence, our specification of probability law must reflect this uncertainty. One way to capture the uncertainty associated with network configuration is via probability law on available production capacity of individual vertices.

This approach is developed in Chapter V. Another approach is to model network topology as a random graph [42]. Our initial work in this direction includes modeling a fixed structure of tiers with random multifurcation coefficients (supply allocation). Investigating random structure of tiers is a subject of future research.

Suppose that  $A_{ji}$  are random variables with known distribution functions  $F_{A_{ji}}(a) = P\{A_{ji} \leq a\}$ ,  $i, j = 1, 2, \dots, n$ ;  $0 \leq a \leq 1$  and probability mass functions  $p_{A_{ij}}(a) = P\{A_{ij} = a\}$ ,  $i, j = 1, 2, \dots, n$ ;  $0 \leq a \leq 1$ . We introduce the following assumptions on independence of  $A_{ji}$ : two multifurcation coefficients  $A_{ji}$  and  $A_{hg}$  are pairwise independent if  $j \neq h$  ( $A_{ji}$  and  $A_{hg}$  are associated with arcs emanating from different vertices). If  $j = h$ , then  $A_{ji}$  and  $A_{hg}$  are not pairwise independent through the identity

$$\sum_{i \in N_k} A_{ji} = 1,$$

for any  $j \in N_{k+1}$ ,  $k = 1, 2, \dots, m$ . For example, on Figure 15, factors  $A_{ji_k}$ ,  $k = 1, 2, \dots$  are pairwise dependent. Factors  $A_{ji_1}$  and  $A_{i_1h_1}$  are pairwise independent, as are  $A_{ji_1}$  and  $A_{i_1h_2}$ ,  $A_{ji_1}$  and  $A_{i_1h_3}$ .

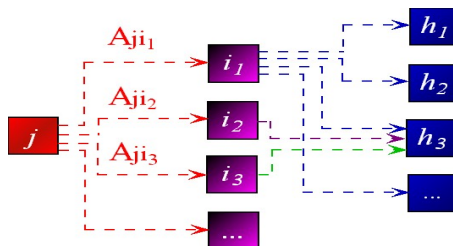

Fig. 15. Independence of multifurcation coefficients.

Suppose that each unique  $i^{th}$  path ( $i = 1, 2, \dots$ ) from vertex  $j \in N_k$  to point of delivery is in the form of

$$L_j^i = \{j, j_1^i \in N_{k-1}, j_2^i \in N_{k-2}, \dots, j_{k-2}^i \in N_2, 1 \in N_1\},$$

and the product of the corresponding multifurcation coefficients is given by

$$A_j^i = A_{jj_1^i} A_{j_1^i j_2^i} \dots A_{j_{k-2}^i 1}, \quad i = 1, 2, \dots \quad (4.18)$$

We have the following proposition

**Proposition 10** *The distribution of  $\bar{A}_j$  of vertex  $j$  is given by*

$$\bar{F}_{\bar{A}_j}(a) = P\{\bar{A}_j > a\} = P\{A_j^1 > a, A_j^2 > a, \dots\},$$

for all  $i = 1, 2, \dots$ ,  $0 \leq a \leq 1$ .

*Proof.* We have that

$$\bar{F}_{\bar{A}_j}(a) = P\{\bar{A}_j > a\} \stackrel{def}{=} P\{\min_i \{A_j^i\} > a\} = P\{A_j^1 > a, A_j^2 > a, \dots\}.$$

■

We will analyze Proposition 10 for overlapping and non-overlapping paths. As a reminder, paths  $L_j^1$  and  $L_j^2$  are overlapping, if they have at least one common arc, and non-overlapping otherwise. Consider two non-overlapping paths  $L_j^1$  and  $L_j^2$  of vertex  $j \in N_k$ :

$$L_j^1 = \{j, j_1^1 \in N_{k-1}, j_2^1 \in N_{k-2}, \dots, j_{k-2}^1 \in N_2, 1 \in N_1\}$$

$$L_j^2 = \{j, j_1^2 \in N_{k-1}, j_2^2 \in N_{k-2}, \dots, j_{k-2}^2 \in N_2, 1 \in N_1\}.$$

Let the corresponding products of multifurcation coefficients of the paths be  $A_j^1$  and  $A_j^2$  respectively:

$$A_j^1 = A_{jj_1^1} A_{j_1^1 j_2^1} \dots A_{j_{k-2}^1 1}$$

$$A_j^2 = A_{jj_1^2} A_{j_1^2 j_2^2} \dots A_{j_{k-2}^2 1}.$$

Knowing that  $A_{j_1^1 j_2^1}, \dots, A_{j_{k-2}^1 1}$  and  $A_{j_1^2 j_2^2}, \dots, A_{j_{k-2}^2 1}$  are all pairwise independent, as

are  $A_{j_1^1 j_2^1}, \dots, A_{j_{k-2}^1}$  and  $A_{j j_1^2}, A_{j_1^2 j_2^2}, \dots, A_{j_{k-2}^2}$ , we have that

$$\begin{aligned}
& P\{\min\{A_j^1, A_j^2\} > a\} = \\
& = P\{A_j^1 > a, A_j^2 > a\} \\
& = P\{A_{j j_1^1} A_{j_1^1 j_2^1} \dots A_{j_{k-2}^1} > a, A_{j j_1^2} A_{j_1^2 j_2^2} \dots A_{j_{k-2}^2} > a\} \\
& = \sum_{x_1} P\{A_{j_1^1 j_2^1} \dots A_{j_{k-2}^1} > a/x_1, A_{j j_1^2} A_{j_1^2 j_2^2} \dots A_{j_{k-2}^2} > a\} P\{A_{j j_1^1} = x_1\} \\
& = \sum_{x_1} P\{A_{j_1^1 j_2^1} \dots A_{j_{k-2}^1} > a/x_1\} P\{A_{j j_1^2} A_{j_1^2 j_2^2} \dots A_{j_{k-2}^2} > a\} P\{A_{j j_1^1} = x_1\} \\
& = \sum_{x_1} P\{A_{j_1^1 j_2^1} \dots A_{j_{k-2}^1} > a/x_1\} \bar{F}_{A_j^2}(a) p_{A_{j j_1^1}}(x_1).
\end{aligned}$$

To extend this approach to networks having more than two non-overlapping paths  $L_j^i$ ,  $i = 2, 3, \dots$ , we need only determine pairwise minimums of the corresponding  $A_j^i$ :

$$\bar{A}_j = \min_{i=2,3,\dots} \{A_j^i\} = \min\{\dots, \min\{A_j^3, \min\{A_j^1, A_j^2\}\}\}.$$

Now consider two paths  $L_j^1$  and  $L_j^2$  emanating from vertex  $j \in N_k$  that overlap through one common arc. Assume, without loss of generality, that this common arc connects vertices  $j \in N_k$  and  $j_1^1 \in N_{k-1}$  with corresponding multifurcation coefficient  $A_{j j_1^1}$ . Downstream of  $j_1^1$ , the paths do not intersect, so that they are two non-overlapping paths emanating from vertex  $j_1^1$ . Let the corresponding products of multifurcation coefficients of the paths be  $A_j^1$  and  $A_j^2$  respectively:

$$\begin{aligned}
A_j^1 &= A_{j j_1^1} A_{j_1^1 j_2^1} \dots A_{j_{k-2}^1}, \\
A_j^2 &= A_{j j_1^1} A_{j_1^1 j_2^2} \dots A_{j_{k-2}^2}.
\end{aligned}$$

Define  $\Psi$  as

$$\Psi = \min\{A_{j_1^1 j_2^1} \dots A_{j_{k-2}^1}, A_{j_1^1 j_2^2} \dots A_{j_{k-2}^2}\}.$$

Then

$$\min\{A_j^1, A_j^2\} = A_{jj_1} \Psi.$$

Note that  $\Psi$  and  $A_{jj_1}$  are independent, since  $\Psi$  is a function of random variables all of which are pairwise independent of  $A_{jj_1}$ . Since  $A_{j_1 j_2}^1 \dots A_{j_{k-2} 1}^1$  is written only in terms of  $A_{j_1 j_2}^1, \dots, A_{j_{k-2} 1}^1$ , and  $A_{j_1 j_2}^2 \dots A_{j_{k-2} 1}^2$  is written only in terms of  $A_{j_1 j_2}^2, \dots, A_{j_{k-2} 1}^2$ , it follows that these are products of independent random variables. Hence,

$$\begin{aligned} \bar{F}_\Psi(a) &= P\{\min\{A_{j_1 j_2}^1 \dots A_{j_{k-2} 1}^1, A_{j_1 j_2}^2 \dots A_{j_{k-2} 1}^2\} > a\} \\ &= P\{A_{j_1 j_2}^1 \dots A_{j_{k-2} 1}^1 > a, A_{j_1 j_2}^2 \dots A_{j_{k-2} 1}^2 > a\} \\ &= P\{A_{j_1 j_2}^1 \dots A_{j_{k-2} 1}^1 > a\} P\{A_{j_1 j_2}^2 \dots A_{j_{k-2} 1}^2 > a\}. \end{aligned}$$

Finally, since  $\Psi$  and  $A_{jj_1}$  are mutually independent, we obtain for  $0 \leq a \leq 1$ :

$$P\{\min\{A_j^1, A_j^2\} > a\} = P\{A_{jj_1} > a, \Psi > a\} = \bar{F}_{A_{jj_1}}(a) \bar{F}_\Psi(a). \quad (4.19)$$

In this section we have modeled random multifurcation coefficients with a fixed structure of tiers. We have shown that under certain assumptions of independence among  $A_{ji}$ s, the distribution of  $\bar{A}_j$  exhibits a fairly simple form for non-overlapping paths. For large enterprises with complex, multi-tier topology and many involute overlapping paths, the analysis becomes complicated. As we propagate upstream the network, our knowledge of configuration of suppliers becomes less certain. In the presence of little or no historical data, specification of probability law on multifurcation coefficients can become very intricate.

## CHAPTER V

## STOCHASTIC MODELS FOR AVAILABLE EFFECTIVE CAPACITY OF THE NETWORK

Development of appropriate stochastic models that capture the dynamics of network capacity disruptions is one of the most important objectives of this research. Our main focus will be on point of delivery, and the corresponding stochastic process  $\{C_{e_1}(t), t \geq 0\}$ , which is dependent, through the feed-forward, flow-matching network, on the family of processes  $\{C_{e_i}(t), i \in N, t \geq 0\}$ .

In Chapter III, Proposition 3 provided us with a key result that for independent operations, the complimentary distribution of available effective capacity of a network, for fixed  $t \geq 0$ , is the product of complimentary distributions of available production capacity of individual vertices:

$$\bar{F}_{C_{e_1}(t)}(\alpha) = \prod_{j=1}^n \bar{F}_{C_{p_j}(t)}(\alpha/\bar{A}_j), \quad \alpha \geq 0, t > 0.$$

This chapter develops four stochastic models that characterize dynamics of available production capacity at individual vertices exposed to random disruptions.

In section A we consider stepwise capacity loss with instantaneous capacity recovery model. This behavior is suitable for a number of industrial scenarios. One example is a limited availability of repair personnel and performance degradation caused by failing equipment/tooling (quality issues) with a subsequent repair upon complete failure. Or, it can be non-self-announcing equipment failures causing stepwise performance degradation. Upon detection, the problem is fixed in a very short time so that repair time is negligible. Or, piecewise equipment modernization when available production capacity decreases stepwise (possibly, to zero). Upon complete modernization, the capacity is instantaneously restored. Or, piecewise reset of equip-



ment due to a shift to manufacturing of a new product.

Section B presents an instantaneous capacity loss with instantaneous recovery. This capacity pattern can be applicable to model emergency power outage, water (gas, heat) supply disruptions, as well as disruptions in any infrastructure system (IT, telephone, etc.).

The instantaneous capacity loss with instantaneous recovery model is extended to an instantaneous capacity loss with constant recovery rate model in section C. This paradigm is appropriate for modeling, for example, instantaneous types of disruptions presented in the previous model when capacity restoration occurs gracefully (approximately). A graceful restoration can be due to a number of reasons. One example, is a failure (reset, maintenance procedures, or gradual modernization/testing) of a complex multi-line equipment. Another example is a terrorist attack threat/warning followed by area search/checking with a gradual restoration of human and manufacturing resources. Or, it can be a limited availability of (outside) repair personnel. Or, it can be a compressed air/steam failure. In this case, production capacity is restoring with a gradual increase in the compressed air/steam pressure. One more example is modeling an extended warmup period of a failed equipment.

Finally, in section D we consider a constant capacity loss rate with a constant rate of recovery. Graceful capacity degradation and restoration is suitable to modeling events impacting labor (labor strikes, political riots, epidemics (e.g., SARS), etc.). Gradual modernization (reset, maintenance) followed by a gradual recovery is another example of this capacity behavior.

A. *Stepwise capacity loss with instantaneous recovery*

Consider our first model describing the dynamics of available production capacity at a vertex  $j \in N_k$ .

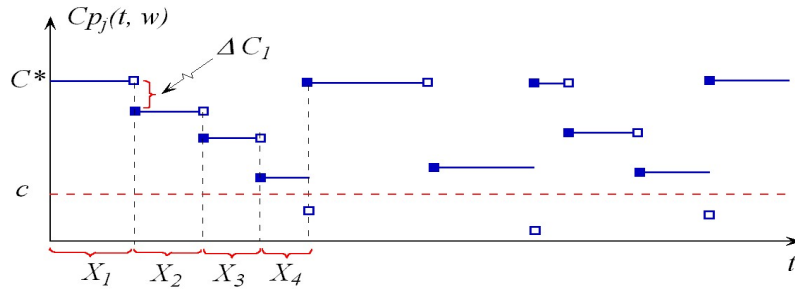

Fig. 16. Stepwise capacity loss with instantaneous capacity recovery.

Initially,  $C_{p_j}(0) = C^*$ , where  $C^*$  is set apriori based on demand. In general,  $C^*$  is vertex dependent, since each vertex has a different demand function. We will omit the  $j$ -th index for  $C^*$ . This notational convention will be preserved for later models. Capacity is subject to disruptions causing instantaneous random stepwise capacity degradation. Disruptions occur one at a time. Following each disturbance, if the amount of available capacity exceeds a critical level  $c$ , the system continues to operate at the disrupted level. If, after a disruption, the amount of available capacity falls below level  $c$ , the vertex instantly recovers its capacity to the target level  $C^*$ . Figure 16 shows a realization of the process. We assume that the points of recovery form a sequence of stopping times at which the process stochastically regenerates, so that  $\{C_{p_j}(t), t \geq 0\}$  forms a regenerative stochastic process.

We use the following notation for vertex  $j$ :

$C^*$  - target capacity level,  $C^* > 0$ .

$c$  - critical capacity level,  $0 \leq c < C^*$ .

$\Delta C_n$  - magnitude of the  $n$ -th capacity loss,  $0 \leq \Delta C_n \leq C^*$ ,  $n \in \mathbb{N}$ .

$X_1$  - epoch of the first capacity loss.

$X_n$  - time between capacity losses  $n - 1$  and  $n$ ,  $n \geq 2$ .

Let  $Z_0 = 0$ , and

$$Z_n = \sum_{j=1}^n X_j, \quad n = 1, 2, \dots \quad (5.1)$$

be the arrival epoch of the  $n$ -th capacity loss.

Available production capacity of vertex  $j$  is a nonnegative random variable. If, at any time  $t > 0$ , the cumulative amount of lost capacity exceeds  $C^*$ , we say that  $C_{p_j}(t) = 0$ . Suppose that capacity losses occur as a renewal process, with  $\{X_n\}$  being independent and identically distributed. We also assume that  $\{\Delta C_n, n \in \mathbb{N}\}$  form a sequence of independent and identically distributed random variables that are independent of the  $\{X_n\}$ . Beginning with  $\{C_{p_j}(t), t \geq 0\}$  process, we define the regenerative process  $\{B_t^u, 0 \leq u \leq C^*, t \geq 0\}$  with state space  $\{0, 1\}$  (see Figures 17 and 18), where:

$$B_t^u = \begin{cases} 1, & \text{if } C_{p_j}(t) \geq u; \\ 0, & \text{otherwise.} \end{cases}$$

The process is in state one when the amount of available production capacity is at least  $u$ , and it is in state zero otherwise. Any epoch, where available production capacity falls below  $u$ , initiates a transition from state one to state zero. Any epoch where available production capacity falls below  $c$  is a transition from state zero to state one, and the process regenerates. Therefore, the process  $\{B_t^u, 0 \leq u \leq C^*, t \geq 0\}$  has the same stopping times as  $\{C_{p_j}(t), t \geq 0\}$ .

We define a cycle as a portion of the process between two adjacent transitions from zero to one (see Figure 17). Let  $T_u$  denote the amount of time that  $C_{p_j} \geq u$ , i.e., is in state one during a one/zero cycle, and let  $T$  denote the length of time of a

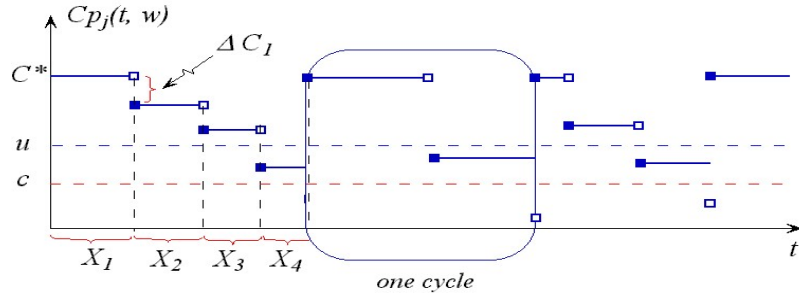

Fig. 17.  $\{C_{p_j}(t)\}$  process of model 1.

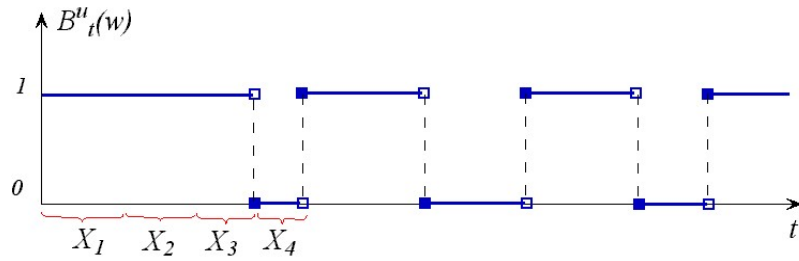

Fig. 18. Corresponding  $\{B_t^u\}$  process of model 1.

cycle. Consider the first cycle, and let

$$N_x = \min\{n \text{ s.t. } \Delta C_1 + \Delta C_2 + \cdots + \Delta C_n > C^* - x\}.$$

That is,  $N_x$  is the index of the first capacity disturbance for which a cumulative loss in available capacity up to this epoch has been exceeding  $C^* - x$ , or the index of the first capacity loss that causes available capacity to fall below  $x$ . Note that

$$T_u = Z_{N_u}, \text{ and} \quad (5.2)$$

$$T = Z_{N_c}. \quad (5.3)$$

We have the following proposition.

**Proposition 11** *For stepwise capacity loss with instantaneous capacity recovery,*

$$\lim_{t \rightarrow \infty} P\{C_{p_j}(t) \geq u\} = \frac{E(N_u)}{E(N_c)},$$

where  $c \leq u \leq C^*$ .

*Proof.* To prove, we use Proposition 3.7.1 in [43], (5.2), (5.3), and the fact that the  $\{X_n\}$  are i.i.d., independent of the  $\{\Delta C_n\}$ :

$$\begin{aligned} \lim_{t \rightarrow \infty} P\{C_{p_j}(t) \geq u\} &= \frac{E(T_u)}{E(T)} \\ &= \frac{E(Z_{N_u})}{E(Z_{N_c})} \\ &= \frac{E\left(\sum_{j=1}^{N_u} X_j\right)}{E\left(\sum_{j=1}^{N_c} X_j\right)} \quad \text{by definition of } Z_n \text{ in (5.1), and} \\ &= \frac{E(N_u)E(X_1)}{E(N_c)E(X_1)} \quad \{X_n\} \text{ are i.i.d., independent of } \{\Delta C_n\} \\ &= \frac{E(N_u)}{E(N_c)}. \end{aligned}$$

■

Now define

$$\tilde{N}_x = \max\{n \text{ s.t. } \Delta C_1 + \Delta C_2 + \cdots + \Delta C_n \leq x\}.$$

$\tilde{N}_x$  is the index of the last capacity loss for which a cumulative loss in available capacity does not exceed  $x$ . Since  $\Delta C_i$  are independent nonnegative random variables, then  $\tilde{N}_x$  is a renewal process. From the elementary renewal theorem it follows that

$$\lim_{t \rightarrow \infty} \frac{E(\tilde{N}_t)}{t} = \frac{1}{E(\Delta C_1)}. \quad (5.4)$$

Note that  $N_x$  and  $\tilde{N}_x$  are connected through the following simple expression:

$$N_{C^*-x} = \tilde{N}_x + 1. \quad (5.5)$$

**Proposition 12** *For stepwise capacity loss with instantaneous capacity recovery, the limiting complimentary distribution of available production capacity of vertex  $j$  can be approximated by the following expression, where  $c \leq u \leq C^*$ :*

$$\lim_{t \rightarrow \infty} P\{C_{p_j}(t) \geq u\} \approx \frac{(C^* - u) + E(\Delta C_1)}{(C^* - c) + E(\Delta C_1)}.$$

*Proof.* From Proposition 11 and (5.4), it follows that

$$\lim_{t \rightarrow \infty} P\{C_{p_j}(t) \geq u\} = \frac{E(N_u)}{E(N_c)} = \frac{E(\tilde{N}_{C^*-u}) + 1}{E(\tilde{N}_{C^*-c}) + 1} \approx \frac{\frac{C^*-u}{E(\Delta C_1)} + 1}{\frac{C^*-c}{E(\Delta C_1)} + 1} = \frac{(C^* - u) + E(\Delta C_1)}{(C^* - c) + E(\Delta C_1)}.$$

■

Finally, we obtain the following result as a measure of overall network performance

**Proposition 13** *For stepwise capacity loss with instantaneous capacity recovery, the limiting complimentary distribution of available effective capacity of a network can be approximated by the following expression, where  $c \leq u \leq C^*$ :*

$$\lim_{t \rightarrow \infty} P\{C_{e_1}(t) \geq u\} \approx \prod_{j=1}^n \frac{(C^* - u/\bar{A}_j) + E(\Delta C_1)}{(C^* - c) + E(\Delta C_1)}.$$

*Proof.* We use Proposition 3 and Proposition 12 to have

$$\begin{aligned} \lim_{t \rightarrow \infty} P\{C_{e_1}(t) \geq u\} &= \lim_{t \rightarrow \infty} \prod_{j=1}^n P\{C_{p_j}(t) \geq u/\bar{A}_j\} && \text{by Proposition 3} \\ &= \prod_{j=1}^n \lim_{t \rightarrow \infty} P\{C_{p_j}(t) \geq u/\bar{A}_j\} && \text{the product is finite} \\ &\approx \prod_{j=1}^n \frac{(C^* - u/\bar{A}_j) + E(\Delta C_1)}{(C^* - c) + E(\Delta C_1)} && \text{by Proposition 12.} \end{aligned}$$

■

### B. Instantaneous capacity loss with instantaneous recovery

Consider our second model describing the dynamics of available production ca-

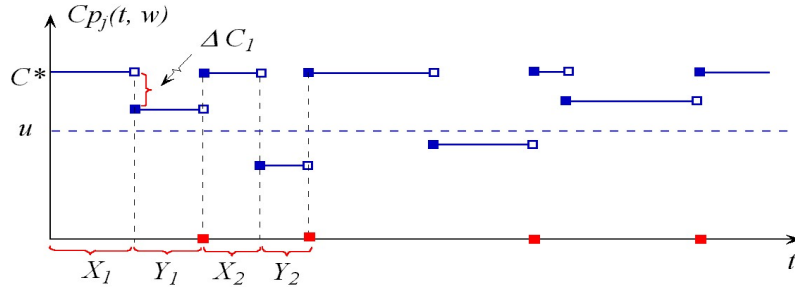

Fig. 19. Instantaneous capacity loss with instantaneous recovery.

capacity at a vertex  $j \in N_k$ .

Initially,  $C_{p_j}(0) = C^*$ . Random disruptions cause immediate random capacity loss. Disruptions occur one at a time. Following each capacity disturbance, the vertex switches to the recovery mode that takes a random amount of time, and then instantly recovers its capacity to the target level. Figure 19 shows a realization of the process. We, again, assume that the points of recovery form a sequence of stopping times at which the system stochastically regenerates, so that  $\{C_{p_j}(t), t \geq 0\}$  forms a regenerative process.

Let  $X_n, n \in \mathbb{N}$  be the amount of time the system operates at target capacity before experiencing the  $n$ -th disruption. Assume  $\{X_n\}$  forms a sequence of independent and identically distributed random variables with known mean  $\mu_X$ . Let  $Y_n, n \in \mathbb{N}$  denote the time of the  $n$ -th disruption period. Assume that  $\{Y_n\}$  forms a sequence of independent and identically distributed random variables with known mean  $\mu_Y$ . In addition, we assume that the sequences  $\{X_n\}$  and  $\{Y_n\}$  are mutually independent. Let  $Z_n = \sum_{i=1}^n (X_i + Y_i)$ ,  $n \in \mathbb{N}$ , so that  $\{Z_n\}$  forms an embedded renewal process. We denote by  $\Delta C_n$  the magnitude of the  $n$ -th capacity loss ( $0 \leq \Delta C_n \leq C^*$ ,  $n \in \mathbb{N}$ ), and assume that  $\{\Delta C_n, n \in \mathbb{N}\}$  forms a sequence of independent and identically distributed random variables with known distribution function  $F_{\Delta C}(x)$ , which are

independent of the  $\{X_n\}$  and  $\{Y_n\}$ . We define the following regenerative process  $\{B_t^u, 0 \leq u \leq C^*, t \geq 0\}$  with state space  $\{0, 1\}$  (see Figures 20 and 21):

$$B_t^u = \begin{cases} 1, & \text{if } C_{p_j}(t) \geq u; \\ 0, & \text{otherwise.} \end{cases}$$

The process is in state one when available production capacity is at least  $u$ , and it is in state zero otherwise. The epoch, where available production capacity falls below  $u$ , initiates a transition from state one to state zero, and the epoch, where available production capacity recovers to the target level, initiates a transition from state zero to state one. The recovery epoch is a point of regeneration. The process  $\{B_t^u, 0 \leq u \leq C^*, t \geq 0\}$  is a thinning of  $\{C_{p_j}(t), t \geq 0\}$  since the sequence of stopping times of  $\{B_t\}$  is a subsequence of the sequence of stopping times of  $\{C_{p_j}(t)\}$ .

Note that transitions from one to zero coincided with an arrival epoch of the renewal process  $\{Z_n\}$ , and the amount of time that  $\{B_t^u\}$  is in state zero is the recovery time for the cycle. We define a cycle as a portion of the process between two adjacent transitions from zero to one (see Figure 21). Let  $T_u$  denote the amount of time that  $C_{p_j} \geq u$ , and let  $T$  denote length of the cycle. Consider the first cycle, and let

$$N_x = \min\{n \text{ s.t. } \Delta C_n > C^* - x\}.$$

$N_x$  is the index of the first capacity loss that causes available capacity to fall below  $x$ . Then the index of the (first) capacity loss that causes the system to experience a transition from one to zero can be expressed as follows

$$\begin{aligned} N_u &= \min\{n \text{ s.t. } \Delta C_n > C^* - u\} \\ &= n \text{ s.t. } \Delta C_n > C^* - u, \end{aligned} \tag{5.6}$$



since after the  $N_u$ -th loss, there are no further capacity losses in this cycle.

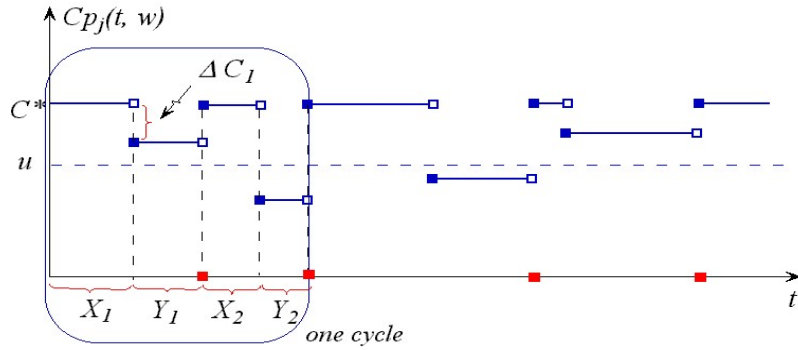

Fig. 20.  $\{C_{p_j}(t)\}$  process of model 2.

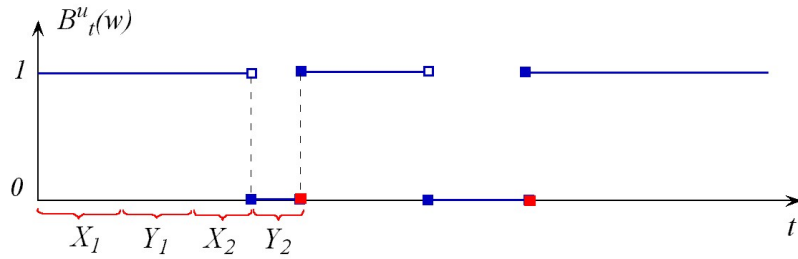

Fig. 21. Corresponding  $\{B_t^u\}$  process of model 2.

A transition from zero to one coincides with an epoch of the renewal process  $\{Z_n\}$ , and, we observe that

$$\begin{aligned} T &= Z_{N_u}, \text{ and} \\ T_u &= Z_{N_u} - Y_{N_u}. \end{aligned} \tag{5.7}$$

**Proposition 14** *For instantaneous capacity loss with instantaneous capacity recovery,*

$$\lim_{t \rightarrow \infty} P\{C_{p_j}(t) \geq u\} = 1 - \frac{\mu_Y}{E(N_u)(\mu_X + \mu_Y)}, \quad 0 \leq u \leq C^*.$$

*Proof.* From Proposition 3.7.1 in [43], (5.7), and the fact that the  $\{X_n\}$  are i.i.d.,  $\{Y_n\}$  are i.i.d., and both are independent of the  $\{\Delta C_n\}$ , we observe that

$$\begin{aligned}
\lim_{t \rightarrow \infty} P\{C_{p_j}(t) \geq u\} &= \frac{E(T_u)}{E(T)} \\
&= \frac{E(Z_{N_u} - Y_{N_u})}{E(Z_{N_u})} \\
&= \frac{E\left(\sum_{j=1}^{N_u} (X_j + Y_j) - Y_{N_u}\right)}{E\left(\sum_{j=1}^{N_u} (X_j + Y_j)\right)} \\
&= \frac{E\left(\sum_{j=1}^{N_u} X_j\right) + E\left(\sum_{j=1}^{N_u-1} Y_j\right)}{E\left(\sum_{j=1}^{N_u} X_j\right) + E\left(\sum_{j=1}^{N_u} Y_j\right)} \\
&= \frac{E(N_u)\mu_X + E(N_u - 1)\mu_Y}{E(N_u)\mu_X + E(N_u)\mu_Y} \\
&= 1 - \frac{\mu_Y}{E(N_u)(\mu_X + \mu_Y)}.
\end{aligned}$$

■

At this point we can estimate  $E(N_u)$  by first obtaining the distribution of  $N_u$ . Consider the first cycle, and let

$$p_u = P\{\Delta C_n > C^* - u\} \text{ for } n = 1, 2, \dots, N_u \quad (\text{since } \Delta C_n \text{ are i.i.d.}). \quad (5.8)$$

Since, for a given cycle,  $N_u$  is the index of the first (and the last) capacity loss having a magnitude that exceeds  $(C^* - u)$ , and since the  $\Delta C_n$  are i.i.d., we can treat them as a sequence of repeated independent trials stopped when the process reaches capacity  $(C^* - u)$ . At this epoch, the process transitions to the recovery mode. For each trial, there are only two possible (mutually exclusive) outcomes: a success event, when the capacity loss exceeds the  $(C^* - u)$  level, and a failure event, when it does not. Therefore,  $N_u$  has a negative binomial distribution with the probability mass function

given by

$$P\{N_u = n\} = p_u (1 - p_u)^{(n-1)} \quad \text{for } n = 1, 2, \dots \quad (5.9)$$

**Proposition 15** *For instantaneous capacity loss with instantaneous capacity recovery,*

$$E(N_u) = \frac{p_u}{1 - p_u} \sum_{k=1}^{\infty} k (1 - p_u)^k.$$

The proof follows directly from (5.9). ■

We now have the following result.

**Proposition 16** *For instantaneous capacity loss with instantaneous capacity recovery, the limiting complimentary distribution of available production capacity of vertex  $j$  is given by the following expression, where  $0 \leq u \leq C^*$ :*

$$\lim_{t \rightarrow \infty} P\{C_{p_j}(t) \geq u\} = 1 - \frac{\mu_Y(1 - p_u)}{(\mu_X + \mu_Y) p_u \sum_{k=1}^{\infty} k (1 - p_u)^k}.$$

*Proof.* From Propositions 14 and 15 it follows that

$$\begin{aligned} \lim_{t \rightarrow \infty} P\{C_{p_j}(t) \geq u\} &= 1 - \frac{\mu_Y}{E(N_u)(\mu_X + \mu_Y)} \\ &= 1 - \frac{\mu_Y(1 - p_u)}{(\mu_X + \mu_Y) p_u \sum_{k=1}^{\infty} k (1 - p_u)^k}. \end{aligned} \quad \blacksquare$$

Finally, we obtain the following result as a measure of overall network performance:

**Proposition 17** *For instantaneous capacity loss with instantaneous capacity recovery, the limiting complimentary distribution of available effective capacity of a network is given by the following expression, where  $\tilde{u}_j = u/\bar{A}_j$ ,  $0 \leq u \leq C^*$ :*

$$\lim_{t \rightarrow \infty} P\{C_{e_1}(t) \geq u\} = \prod_{j=1}^n \left( 1 - \frac{\mu_Y(1 - p_{\tilde{u}_j})}{(\mu_X + \mu_Y) p_{\tilde{u}_j} \sum_{k=1}^{\infty} k (1 - p_{\tilde{u}_j})^k} \right).$$

*Proof.* We use Propositions 3 and 16

$$\begin{aligned}
\lim_{t \rightarrow \infty} P\{C_{e_1}(t) \geq u\} &= \lim_{t \rightarrow \infty} \prod_{j=1}^n P\{C_{p_j}(t) \geq u/\bar{A}_j\} \\
&= \prod_{j=1}^n \lim_{t \rightarrow \infty} P\{C_{p_j}(t) \geq u/\bar{A}_j\} \\
&= \prod_{j=1}^n \left( 1 - \frac{\mu_Y(1-p_{\bar{u}_j})}{(\mu_X + \mu_Y)p_{\bar{u}_j} \sum_{k=1}^{\infty} k(1-p_{\bar{u}_j})^k} \right).
\end{aligned}$$

When  $u = C^*$ , we have the following proposition.

**Proposition 18** *For instantaneous capacity loss with instantaneous capacity recovery, the limiting probability that vertex  $j$  operates at the target capacity is given by*

$$\lim_{t \rightarrow \infty} P\{C_{p_j}(t) = C^*\} = \frac{\mu_X}{\mu_X + \mu_Y}.$$

*Proof.* With  $u = C^*$ , it follows that

$$p_u = P\{\Delta C_n > C^* - u\} = P\{\Delta C_n > 0\} = 1 \quad \text{for } n = 1, 2, \dots, N_u,$$

so that

$$E(N_u) = \frac{p_u}{1-p_u} \sum_{k=1}^{\infty} k(1-p_u)^k = \sum_{k=1}^{\infty} k p_u (1-p_u)^{(k-1)} = p_u + \sum_{k=2}^{\infty} k p_u (1-p_u)^{(k-1)} = 1.$$

It follows from Proposition 14 that

$$\begin{aligned}
\lim_{t \rightarrow \infty} P\{C_{p_j}(t) = C^*\} &= \lim_{t \rightarrow \infty} P\{C_{p_j}(t) \geq C^*\} \\
&= 1 - \frac{\mu_Y}{E(N_u)(\mu_X + \mu_Y)} \\
&= \frac{\mu_X}{\mu_X + \mu_Y}.
\end{aligned}$$

■

**Corollary 5** *For instantaneous capacity loss with instantaneous capacity recovery,*

the limiting probability that a network operates at the target capacity is given by

$$\lim_{t \rightarrow \infty} P\{C_{e_1}(t) = C^*\} = \prod_{j=1}^n \frac{\mu_{X_j}}{\mu_{X_j} + \mu_{Y_j}}.$$

*Proof.* From Proposition 18, the proof is analogous to that of Proposition 17. ■

### C. Instantaneous capacity loss with constant recovery rate

Consider our third model describing the dynamics of available production capacity at a vertex  $j \in N_k$ . Initially,  $C_{p_j}(0) = C^*$ . Capacity disruptions occur one at a time. Following each disruption, the system enters a recovery period, and immediately begins recovering the lost capacity at a constant rate  $\alpha > 0$  until the target level is achieved (see Figure 22). We assume that the points of recovery form a sequence of stopping times at which the system stochastically regenerates, so that  $\{C_{p_j}(t), t \geq 0\}$  forms a regenerative stochastic process.

As before,  $X_n, n \in \mathbb{N}$  denotes the amount of time the system operates at the target level before experiencing the  $n$ -th capacity disruption.  $\{X_n, n \in \mathbb{N}\}$  are assumed to form a sequence of independent and identically distributed random variables with known mean  $\mu_X$ . We denote by  $\Delta C_n$  the magnitude of the  $n$ -th capacity loss ( $0 \leq \Delta C_n \leq C^*, n \in \mathbb{N}$ ), and further assume that  $\{\Delta C_n, n \in \mathbb{N}\}$  forms a sequence of independent and identically distributed random variables, independent of the  $\{X_n\}$ . We let  $Y_n, n \in \mathbb{N}$  to be the length of the  $n$ -th recovery period: with distribution function  $F_{\Delta C}(x), x \in \mathbb{N}$ .

$$Y_n = \frac{\Delta C_n}{\alpha}, \quad \alpha > 0.$$

Then  $\{Y_n\}$  is a sequence of independent and identically distributed random variables with mean  $\mu_{\Delta C}/\alpha$ . In addition, sequences  $\{X_n\}$  and  $\{Y_n\}$  are mutually independent

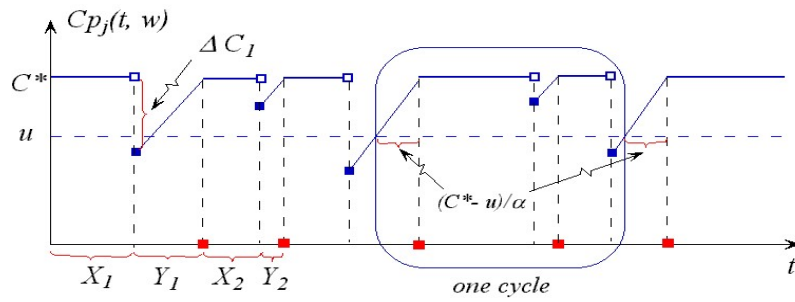

Fig. 22. Instantaneous capacity loss with constant rate recovery.

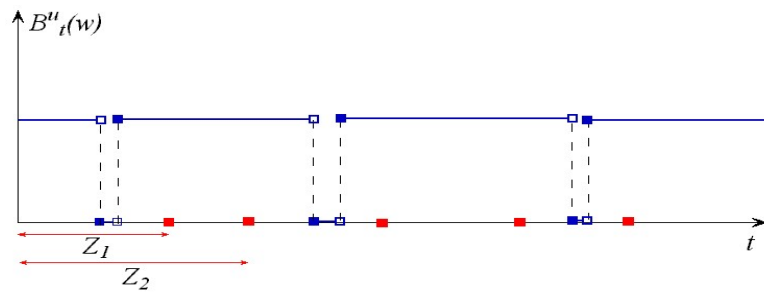

Fig. 23. Corresponding  $\{B_t^u\}$  process of model 3.

since  $\{X_n\}$  and  $\{\Delta C_n\}$  are independent. Let  $Z_n = \sum_{i=1}^n (X_i + Y_i)$ ,  $n \in \mathbb{N}$ , so that  $\{Z_n\}$  forms an embedded renewal process.

Let  $B_t^u$  be defined as before, with the process  $\{B_t^u, t \geq 0\}$  (see Figure 23). The process is in state one when available production capacity is at least  $u$ , and it is in state zero otherwise. When available production capacity falls below  $u$ , the process moves from state one to state zero. When available production capacity recovers to  $u$  (not to the target level, as in the previous model), the process moves from state zero to state one. We define  $T_u$  and  $T$  as in the previous model, and  $N_u$  and  $p_u$  as in

(5.6) and (5.8) respectively. It follows that

$$T = \frac{C^* - u}{\alpha} + Z_{N_u} - \frac{C^* - u}{\alpha} = Z_{N_u}, \quad (5.10)$$

and

$$T_u = \frac{C^* - u}{\alpha} + Z_{N_u} - \frac{\Delta C_{N_u}}{\alpha}. \quad (5.11)$$

**Proposition 19** *For instantaneous capacity loss with a constant recovery rate, the limiting complimentary distribution of available production capacity of vertex  $j$  is given by the following expression, where  $E(N_u) = \sum_{k=1}^{\infty} k p_u (1 - p_u)^{(k-1)}$ ,  $0 \leq u \leq C^*$ :*

$$\lim_{t \rightarrow \infty} P\{C_{p_j}(t) \geq u\} = \frac{(C^* - u)/\alpha + E(N_u)(\alpha\mu_X + \mu_{\Delta C}) - \mu_{\Delta C}}{E(N_u)(\alpha\mu_X + \mu_{\Delta C})}.$$

*Proof.* From Proposition 3.7.1 in [43], Proposition 15, (5.10) and (5.11) we observe that

$$\begin{aligned} \lim_{t \rightarrow \infty} P\{C_{p_j}(t) \geq u\} &= \\ &= \frac{E(T_u)}{E(T)} \\ &= \frac{E((C^* - u)/\alpha + Z_{N_u} - \Delta C_{N_u}/\alpha)}{E(Z_{N_u})} \\ &= \frac{(C^* - u)/\alpha + E(N_u)\mu_X + E(\sum_{i=1}^{N_u} Y_i) - \mu_{\Delta C}/\alpha}{E(N_u)\mu_X + E(\sum_{i=1}^{N_u} Y_i)} \\ &= \frac{(C^* - u)/\alpha + E(N_u)\mu_X + \sum_{n=1}^{\infty} E(\sum_{i=1}^n Y_i)P\{N_u = n\} - \mu_{\Delta C}/\alpha}{E(N_u)\mu_X + \sum_{n=1}^{\infty} E(\sum_{i=1}^n Y_i)P\{N_u = n\}} \\ &= \frac{(C^* - u)/\alpha + E(N_u)\mu_X + (\mu_{\Delta C}/\alpha) \sum_{n=1}^{\infty} nP\{N_u = n\} - \mu_{\Delta C}/\alpha}{E(N_u)\mu_X + (\mu_{\Delta C}/\alpha) \sum_{n=1}^{\infty} nP\{N_u = n\}} \\ &= \frac{(C^* - u)/\alpha + E(N_u)\mu_X + E(N_u)(\mu_{\Delta C}/\alpha) - \mu_{\Delta C}/\alpha}{E(N_u)\mu_X + E(N_u)(\mu_{\Delta C}/\alpha)} \end{aligned}$$

$$= \frac{(C^* - u)/\alpha + E(N_u)(\alpha\mu_X + \mu_{\Delta C}) - \mu_{\Delta C}}{E(N_u)(\alpha\mu_X + \mu_{\Delta C})}.$$

■

We obtain the following result as a measure of overall network performance:

**Proposition 20** *For instantaneous capacity loss with a recovery constant rate, the limiting complimentary distribution of available effective capacity of a network is given by the following expression, where  $\tilde{u}_j = u/\bar{A}_j$ :*

$$\lim_{t \rightarrow \infty} P\{C_{e_1}(t) \geq u\} = \prod_{j=1}^n \frac{(C^* - \tilde{u}_j)/\alpha + E(N_{\tilde{u}_j})(\alpha\mu_X + \mu_{\Delta C}) - \mu_{\Delta C}}{E(N_{\tilde{u}_j})(\alpha\mu_X + \mu_{\Delta C})}.$$

*Proof.* We use Propositions 3 and 19

$$\begin{aligned} \lim_{t \rightarrow \infty} P\{C_{e_1}(t) \geq u\} &= \lim_{t \rightarrow \infty} \prod_{j=1}^n P\{C_{p_j}(t) \geq u/\bar{A}_j\} \\ &= \prod_{j=1}^n \lim_{t \rightarrow \infty} P\{C_{p_j}(t) \geq u/\bar{A}_j\} \\ &= \prod_{j=1}^n \frac{(C^* - \tilde{u}_j)/\alpha + E(N_{\tilde{u}_j})(\alpha\mu_X + \mu_{\Delta C}) - \mu_{\Delta C}}{E(N_{\tilde{u}_j})(\alpha\mu_X + \mu_{\Delta C})}. \end{aligned}$$

■

We have the following important corollary when  $u = C^*$ :

**Corollary 6** *For instantaneous capacity loss with a constant recovery rate, the limiting probability that vertex  $j$  operates at the target capacity is given by*

$$\lim_{t \rightarrow \infty} P\{C_{p_j}(t) = C^*\} = \frac{\alpha\mu_X}{\alpha\mu_X + \mu_{\Delta C}}.$$

*Proof.* We have, as shown in proof of Proposition 18, that  $p_u = 1$ , and  $E(N_u) = 1$ .

From Proposition 19 it follows that

$$\lim_{t \rightarrow \infty} P\{C_{p_j}(t) = C^*\} = \lim_{t \rightarrow \infty} P\{C_{p_j}(t) \geq C^*\} = \frac{\alpha\mu_X}{\alpha\mu_X + \mu_{\Delta C}}.$$



Alternatively, we have (see Figure 24) that

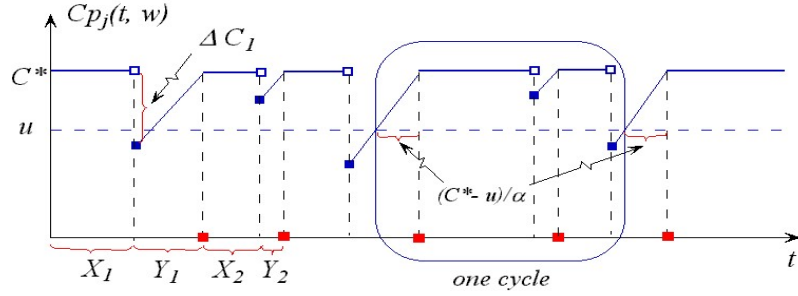

Fig. 24.  $\{C_{p_j}(t)\}$  process of model 3.

$$\begin{aligned}
 N_u &= \min\{n \text{ s.t. } \Delta C_n > C^* - u\} \\
 &= \min\{n \text{ s.t. } \Delta C_n > 0\} \\
 &= 1.
 \end{aligned}$$

Therefore,

$$T = Z_{N_u} = Z_1 = X_1 + \frac{\Delta C_1}{\alpha}, \quad (5.12)$$

and

$$\begin{aligned}
 T_u &= \frac{C^* - u}{\alpha} + Z_{N_u} - \frac{\Delta C_{N_u}}{\alpha} \\
 &= Z_1 - \frac{\Delta C_1}{\alpha} \\
 &= X_1.
 \end{aligned} \quad (5.13)$$

Now from (5.12) and (5.13) we have that

$$\begin{aligned}
\lim_{t \rightarrow \infty} P\{C_{p_j}(t) \geq u\} &= \frac{E(T_u)}{E(T)} \\
&= \frac{\mu_X}{\mu_X + \frac{\mu_{\Delta C}}{\alpha}} \\
&= \frac{\alpha \mu_X}{\alpha \mu_X + \mu_{\Delta C}}.
\end{aligned}$$

■

**Corollary 7** For instantaneous capacity loss with a constant recovery rate, the limiting probability that a network operates at the target capacity is given by

$$\lim_{t \rightarrow \infty} P\{C_{e_1}(t) = C^*\} = \prod_{j=1}^n \frac{\alpha_j \mu_{X_j}}{\alpha_j \mu_{X_j} + \mu_{\Delta C_j}}.$$

The proof follows directly from Proposition 3 and Corollary 6.

■

It is straightforward to extend this analysis to the situation shown in Figure 25.

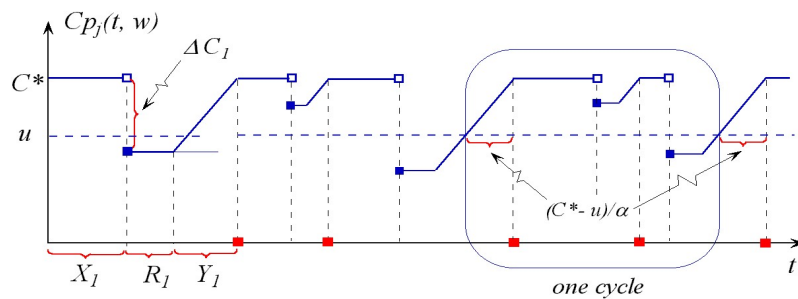

Fig. 25. Including random delay time  $R_n$  in model 3.

In this case, the total recovery time of the  $n$ -th capacity loss consists of a random recovery delay  $R_n, n \in \mathbb{N}$ , when available production capacity remains at the level

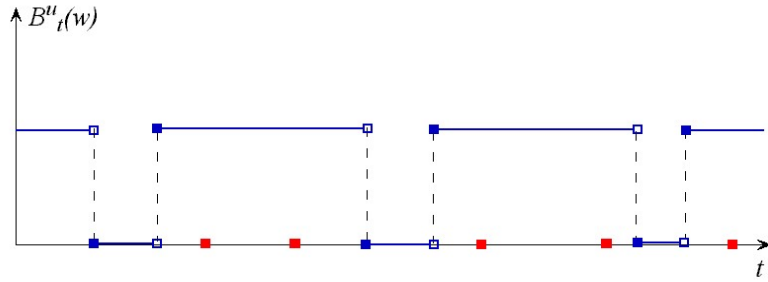

Fig. 26. Corresponding  $\{B_t^u\}$  process of the model.

$C^* - \Delta C_n$ , and time  $Y_n$ ,  $n \in \mathbb{N}$ , required to recover the lost capacity to the target level at a constant rate  $\alpha$ :

$$Y_n = \frac{\Delta C_n}{\alpha}.$$

$R_n$  is a random delay before capacity recovery begins. We assume that  $\{R_n\}$  forms a sequence of independent and identically distributed random variables with mean  $\mu_R$ , mutually independent of  $\{X_n\}$  and  $\{Y_n\}$ , and we define  $Z_n = \sum_{i=1}^n (X_i + R_i + Y_i)$ ,  $n \in \mathbb{N}$ . We have that

$$T = \frac{C^* - u}{\alpha} + Z_{N_u} - \frac{C^* - u}{\alpha} = Z_{N_u}, \quad (5.14)$$

and

$$T_u = \frac{C^* - u}{\alpha} + Z_{N_u} - \left( R_{N_u} + \frac{\Delta C_{N_u}}{\alpha} \right). \quad (5.15)$$

Now we have the following result.

**Proposition 21** *For instantaneous capacity loss and a constant recovery rate with random recovery delay, the limiting complimentary distribution of available production capacity of vertex  $j$  is given by the following expression, where  $0 \leq u \leq C^*$  and*

$$E(N_u) = \sum_{k=1}^{\infty} k p_u (1 - p_u)^{(k-1)}:$$

$$\lim_{t \rightarrow \infty} P\{C_{p_j}(t) \geq u\} = \frac{(C^* - u)/\alpha + E(N_u)(\alpha\mu_X + \alpha\mu_R + \mu_{\Delta C}) - \alpha\mu_R - \mu_{\Delta C}}{E(N_u)(\alpha\mu_X + \alpha\mu_R + \mu_{\Delta C})}.$$

*Proof.* From (5.14) and (5.15), the proof is analogous to that of Proposition 19. ■

**Proposition 22** *For instantaneous capacity loss and a constant recovery rate with random recovery delay, the limiting complimentary distribution of available effective capacity of a network is given by the following expression, where  $\tilde{u}_j = u/\bar{A}_j$ ,  $0 \leq u \leq C^*$ :*

$$\lim_{t \rightarrow \infty} P\{C_{e_1}(t) \geq u\} = \prod_{j=1}^n \frac{(C^* - \tilde{u}_j)/\alpha + E(N_{\tilde{u}_j})(\alpha\mu_X + \alpha\mu_R + \mu_{\Delta C}) - \alpha\mu_R - \mu_{\Delta C}}{E(N_{\tilde{u}_j})(\alpha\mu_X + \alpha\mu_R + \mu_{\Delta C})}.$$

The proof is straightforward by using Propositions 3 and 21. ■

**Corollary 8** *For instantaneous capacity loss and a constant recovery rate with random recovery delay, the limiting probability that vertex  $j$  operates at the target capacity is given by*

$$\lim_{t \rightarrow \infty} P\{C_{p_j}(t) = C^*\} = \frac{\alpha\mu_X}{\alpha\mu_X + \alpha\mu_R + \mu_{\Delta C}}.$$

The proof is analogous to that of Corollary 6. ■

**Corollary 9** *For instantaneous capacity loss and a constant recovery rate with random recovery delay, the limiting probability that a network operates at the target capacity is given by*

$$\lim_{t \rightarrow \infty} P\{C_{e_1}(t) = C^*\} = \prod_{j=1}^n \frac{\alpha_j\mu_{X_j}}{\alpha_j\mu_{X_j} + \alpha_j\mu_{R_j} + \mu_{\Delta C_j}}.$$

The proof is analogous to that of Corollary 7. ■

*D. Constant rate capacity loss with constant recovery rate*

Consider our fourth model describing the dynamics of available production capacity at a vertex  $j \in N_k$ . This model is an extension of the previous model, where, in addition, we allow random graceful capacity losses with a constant rate  $\beta > 0$  (see Figure 27), so that the  $n$ -th capacity loss  $\Delta C_n$  ( $0 \leq \Delta C_n \leq C^*$ ,  $n \in \mathbb{N}$ ) lasts

$$S_n = \frac{\Delta C_n}{\beta}$$

amount of time.

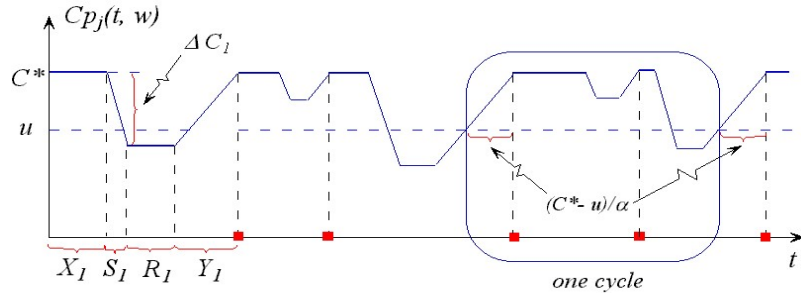

Fig. 27. Loss with a constant rate  $\beta$ , recovery with a constant rate  $\alpha$ .

As before, we assume that total recovery time of the  $n$ -th capacity loss consists of a random recovery delay  $R_n$ ,  $n \in \mathbb{N}$ , and a recovery time  $Y_n$ ,  $n \in \mathbb{N}$ :

$$Y_n = \frac{\Delta C_n}{\alpha}.$$

We let

$$Z_n = \sum_{i=1}^n (X_i + S_i + R_i + Y_i), \quad n \in \mathbb{N}.$$

We have that

$$T = \frac{C^* - u}{\alpha} + Z_{N_u} - \frac{C^* - u}{\alpha} = Z_{N_u}, \quad (5.16)$$

and

$$T_u = \frac{C^* - u}{\alpha} + Z_{N_u} - \left( \frac{\Delta C_{N_u}}{\alpha} + R_{N_u} + \frac{\Delta C_{N_u} - (C^* - u)}{\beta} \right). \quad (5.17)$$

**Proposition 23** *For a constant capacity loss rate with a constant recovery rate,  $E(T)$  and  $E(T_u)$  are given by the following expressions:*

$$E(T) = E(N_u) \frac{\alpha\beta(\mu_X + \mu_R) + (\alpha + \beta)\mu_{\Delta C}}{\alpha\beta},$$

$$E(T_u) = \frac{(\alpha + \beta)(C^* - u - \mu_{\Delta C}) - \alpha\beta\mu_R + E(N_u)(\alpha\beta(\mu_X + \mu_R) + (\alpha + \beta)\mu_{\Delta C})}{\alpha\beta}.$$

*Proof.* From (5.16) and (5.17) we have that

$$\begin{aligned} E(T) &= E(Z_{N_u}) \\ &= E(N_u) \frac{\alpha\beta(\mu_X + \mu_R) + (\alpha + \beta)\mu_{\Delta C}}{\alpha\beta}, \end{aligned}$$

where

$$E(N_u) = \frac{p_u}{1 - p_u} \sum_{k=1}^{\infty} k (1 - p_u)^k. \quad (5.18)$$

It follows that

$$E(T_u) = E\left( \frac{C^* - u}{\alpha} + Z_{N_u} - \left( \frac{\Delta C_{N_u}}{\alpha} + R_{N_u} + \frac{\Delta C_{N_u} - (C^* - u)}{\beta} \right) \right)$$

$$\begin{aligned}
&= \frac{C^* - u}{\alpha} + E(N_u) \frac{\alpha\beta(\mu_X + \mu_R) + (\alpha + \beta)\mu_{\Delta C}}{\alpha\beta} \\
&\quad - \left( \frac{\mu_{\Delta C}}{\alpha} + \mu_R + \frac{\mu_{\Delta C} - (C^* - u)}{\beta} \right) \\
&= \frac{(\alpha + \beta)(C^* - u - \mu_{\Delta C}) - \alpha\beta\mu_R + E(N_u)(\alpha\beta(\mu_X + \mu_R) + (\alpha + \beta)\mu_{\Delta C})}{\alpha\beta}.
\end{aligned}$$

■

**Proposition 24** *For a constant capacity loss rate with a constant recovery rate, the limiting complimentary distribution of available production capacity of vertex  $j$  is given by the following expression, where  $E(N_u) = \sum_{k=1}^{\infty} k p_u (1 - p_u)^{(k-1)}$  and  $0 \leq u \leq C^*$ :*

$$\begin{aligned}
\lim_{t \rightarrow \infty} P\{C_{p_j}(t) \geq u\} &= \frac{(\alpha + \beta)(C^* - u - \mu_{\Delta C}) - \alpha\beta\mu_R + E(N_u)(\alpha\beta(\mu_X + \mu_R))}{E(N_u)[\alpha\beta(\mu_X + \mu_R) + (\alpha + \beta)\mu_{\Delta C}]} \\
&\quad + \frac{(\alpha + \beta)\mu_{\Delta C}}{E(N_u)[\alpha\beta(\mu_X + \mu_R) + (\alpha + \beta)\mu_{\Delta C}]}.
\end{aligned}$$

The proof follows directly from Proposition 23.

■

**Proposition 25** *For a constant capacity loss rate with a constant recovery rate, the limiting complimentary distribution of available effective capacity of a network is given by the following expression, where  $\tilde{u}_j = u/\bar{A}_j$ :*

$$\begin{aligned}
&\lim_{t \rightarrow \infty} P\{C_{e_1}(t) \geq u\} \\
&= \prod_{j=1}^n \left( \frac{(\alpha + \beta)(C^* - \tilde{u}_j - \mu_{\Delta C}) - \alpha\beta\mu_R + E(N_{\tilde{u}_j})(\alpha\beta(\mu_X + \mu_R) + (\alpha + \beta)\mu_{\Delta C})}{E(N_{\tilde{u}_j})(\alpha\beta(\mu_X + \mu_R) + (\alpha + \beta)\mu_{\Delta C})} \right).
\end{aligned}$$

The proof is straightforward using Proposition 3 and Proposition 24.

■

**Corollary 10** *For a constant capacity loss rate with a constant recovery rate, the limiting probability that vertex  $j$  operates at the target capacity is given by*

$$\lim_{t \rightarrow \infty} P\{C_{p_j}(t) = C^*\} = \frac{\alpha\beta\mu_X}{\alpha\beta(\mu_X + \mu_R) + (\alpha + \beta)\mu_{\Delta C}}.$$

*Proof.* When  $u = C^*$ , we have (see Figures 28 and 29) that:

$$N_u = \min\{n \text{ s.t. } \Delta C_n > C^* - u\} = 1.$$

Therefore,

$$T = Z_{N_u} = Z_1 = X_1 + \frac{\Delta C_1}{\beta} + \mu_R + \frac{\Delta C_1}{\alpha},$$

and

$$\begin{aligned} T_u &= \frac{C^* - u}{\alpha} + Z_{N_u} - \left( \frac{\Delta C_{N_u}}{\alpha} + R_{N_u} + \frac{\Delta C_{N_u} - (C^* - u)}{\beta} \right) \\ &= Z_1 - \left( \frac{\Delta C_1}{\alpha} + R_1 + \frac{\Delta C_1}{\beta} \right) \\ &= X_1. \end{aligned}$$

Now we have that

$$\begin{aligned} \lim_{t \rightarrow \infty} P\{C_{p_j}(t) \geq u\} &= \frac{E(T_u)}{E(T)} \\ &= \frac{\mu_X}{\mu_X + \frac{\mu_{\Delta C}}{\beta} + \mu_R + \frac{\mu_{\Delta C}}{\alpha}} \\ &= \frac{\alpha\beta\mu_X}{\alpha\beta(\mu_X + \mu_R) + (\alpha + \beta)\mu_{\Delta C}}. \end{aligned}$$

■



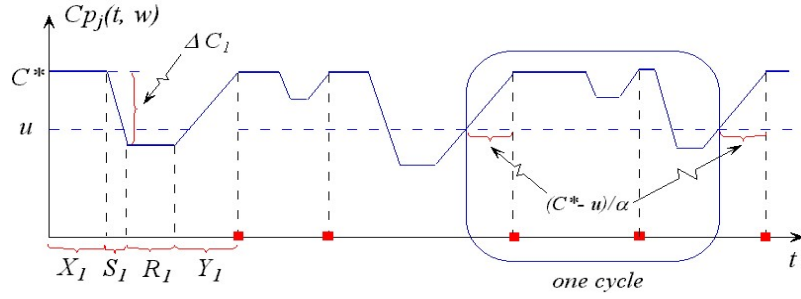

Fig. 28.  $\{C_{p_j}(t)\}$  process of model 4.

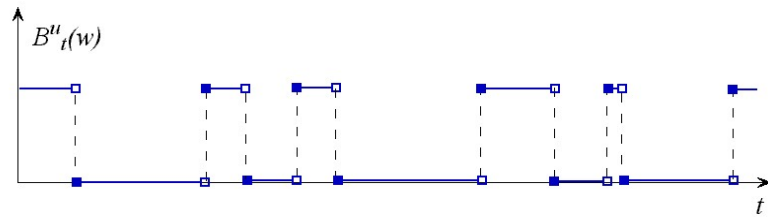

Fig. 29.  $\{B_t^u\}$  process when  $u = C^*$  of model 4.

Finally,

**Corollary 11** *For a constant capacity loss rate with a constant recovery rate, the limiting probability that a network operates at the target capacity is given by*

$$\lim_{t \rightarrow \infty} P\{C_{e_1}(t) = C^*\} = \prod_{j=1}^n \frac{\alpha_j \beta_j \mu_{X_j}}{\alpha_j \beta_j (\mu_{X_j} + \mu_{R_j}) + (\alpha_j + \beta_j) \mu_{\Delta C_j}}.$$

The proof follows directly from Proposition 3 and Corollary 10.

In this chapter we have imposed certain capacity dynamics on the underlying feed-forward, flow-matching network model. In the presence of independent available production capacities, in order to characterize stochastic dynamics of the network, it is sufficient to describe the dynamics of individual vertices. We have developed

four stochastic models that capture this dynamics. These models can be applied or extended to cover a large variety of capacity disruption scenarios. Drivers of these disruptions, affecting both human and technological resources, can range from accidents and natural disasters to man-made distortions like labor strikes, political riots, computer viruses, and terrorist attacks.

For each developed model, we have derived the limiting distribution of available effective capacity of the network. As a special case, we have obtained the limiting probability that the network operates at a fixed target capacity level set a priori based on demand. The product-type form of these probabilistic results suggest that large, lean enterprise networks are brittle, their ability to sustain demand is susceptible to even minor upstream disruptions. Another important conclusion is that for a complex, dynamic manufacturing environment, in the presence of little or no historical data, capturing probability law on capacity degradation and restoration can be very intricate.

To best of our knowledge, these results give, for the first time, an analytical characterization of capacity dynamics at the network level. The analytical approach that we have developed can be integrated with decision support methodologies based on risk theory and expected utility theory, to focus on strategic risk management and enterprise network design. Obtaining transient phase results, modeling event-dependent capacity losses, introducing random target capacity levels, and combining different capacity disruption scenarios for one network constitute a promising venue for future research.

## CHAPTER VI

## CONCLUSIONS AND FUTURE RESEARCH

We have developed a number of stochastic models that capture the dynamics of capacity disruptions in complex multi-tier feed-forward, flow-matching networks. We derived an expression for available effective capacity of point of delivery, proposed a useful interpretation of this result in terms of paths, followed by the derivation of the distribution of available effective capacity of a network. In addition, we relaxed some basic structural assumptions of FFN, introduced random propagation times, studied the impact of inventory buffers on propagation times, and made initial efforts to model a random network topology. We considered SFFN as a special case.

For a fixed network topology and a fixed time, available effective capacity of the network is a complicated nonlinear function of available production capacity of individual vertices. The result is further complicated by introduction of random propagation times and random network architecture. However, under the assumption of independence of production capacities, the complimentary distribution of available effective capacity exhibits a fairly simple product form. Analysis of this result suggests that lean feed-forward, flow-matching enterprise networks are brittle - the output of such networks is vulnerable to minor upstream disruptions. In addition, enterprise topology is often traceable to at most two-three upstream tiers. Furthermore, most enterprises do not have a long history of company-specific data, and in many instances, company owned data are not representative to model current and future disruptions. Thus, capturing the probability law on available effective capacity can be difficult.

Analysis of feed-forward flow-matching networks developed in Chapters III and IV, and stochastic models presented in Chapter V give, for the first time, an analytical characterization of stochastic dynamics for feed-forward, flow-matching networks.

We have developed four stochastic models that can be applied or extended to model a large variety of capacity disruption scenarios. Additionally, we have explored the dynamics of capacity disruptions throughout the network, i.e., at the enterprise level. As is pointed in Chapter II, most literature on production and inventory control, supply chain, and manufacturing systems which considers disruptions, focuses on traditional localized issues of inventory, production lot sizing, production scheduling, and cost management. To the best of our knowledge, this is the first set of results reporting a model that captures capacity dynamics at the network level. The analytical approach that we have developed can be integrated with decision support methodologies based on risk theory and expected utility theory, to focus on strategic risk management and enterprise network design.

Future research embraces a number of objectives: 1) to obtain conversion metrics that transforms available effective capacity at point of delivery to a reward, and investigate associated stochastic processes. In the simplest case, reward is a linear function of the network effective capacity, having the same time basis, so that the limiting distribution function of reward is as follows:

$$\bar{F}_{kC_{e_1}(t)}(\alpha) = \prod_{j=1}^n \bar{F}_{C_{p_j}(t)}(\alpha/k\bar{A}_j), \quad \alpha \geq 0, t \geq 0, k > 0, \quad (6.1)$$

and results developed in Chapter V can be extended using (6.1); 2) to refine existing stochastic models and obtain transient phase results in special cases. For example, it can be shown that for instantaneous capacity loss with instantaneous recovery, with exponentially distributed  $X_n$  and  $Y_n$  with means  $1/\beta_X$  and  $1/\beta_Y$  respectively, and fixed  $t \geq 0$ , the probability that vertex  $j$  operates at target level  $C^*$  is given by:

$$P\{C_{p_j}(t) = C^*\} = \frac{\beta_Y}{\beta_X + \beta_Y} + \frac{\beta_X}{\beta_X + \beta_Y} e^{-(\beta_X + \beta_Y)t}. \quad (6.2)$$

Note that as  $t \rightarrow \infty$ , (6.2) gives the result of Proposition 18; 3) to model random structure of tiers  $N_k$ ,  $k = 1, 2, \dots, m$ . Analysis of random multifurcation coefficients  $A_{ji}$  for a fixed network structure from section E of Chapter IV can be extended, and combined with approaches from reverse engineering (i.e., conjecturing upstream suppliers based on successive product decomposition); 4) to further relax structural assumptions of FFN, in particular, the assumption that a network has a single point of delivery. If a network has multiple points of delivery, it can be decomposed into several networks each having a single output vertex, so that topology results from Chapter III can be applied to obtain an aggregate effective capacity of the complex network.

Ultimately, we want to develop methodologies to analytically support strategic design of enterprise infrastructure. The developed network algebra and stochastic models serve as a foundation of this research iceberg.

## REFERENCES

- [1] C. L. Marshall, *Measuring and Managing Operational Risks in Financial Institutions: Tools, Techniques, and Other Resources*, New York, NY: John Wiley & Sons, Inc., 2001.
- [2] D. Barnes-Schuster, Y. Bassok, and R. Anupindi, “Coordination and flexibility in supply contracts with options,” *Manufacturing & Service Operations Management*, vol. 4, pp. 171–207, 2002.
- [3] K. L. Cheung and H. L. Lee, “The inventory benefit of shipment coordination and stock rebalancing in a supply chain,” *Management Science*, vol. 48, pp. 300–306, 2002.
- [4] J. M. Milner and P. Kouvelis, “On the complementary value of accurate demand information and production and supplier flexibility,” *Manufacturing & Service Operations Management*, vol. 4, pp. 99–113, 2002.
- [5] C. J. Corbett and G. A. DeCroix, “Shared-savings contracts for indirect materials in supply chains: channel profits and environmental impacts,” *Management Science*, vol. 47, pp. 881–893, 2001.
- [6] H. Lee, P. Padamanabhan, and S. Whang, “Information distortion in supply chain: the bullwhip effect,” *Management Science*, vol. 43, pp. 546–558, 1997.
- [7] R. R. Meyer, M. H. Rothkopf, and S. A. Smith, “Reliability and inventory in a production storage system,” *Management Science*, vol. 25, pp. 799–807, 1979.
- [8] M. J. Posner and M. Berg, “Analysis of a production-inventory system with unreliable production facility,” *Operations Research Letters*, vol. 8, pp. 339–345, 1989.

- [9] A. Arreola-Risa and C. A. DeCroix, “Inventory management under random supply disruptions and partial backorders,” *Naval Research Logistics*, vol. 45, pp. 687–703, 1998.
- [10] M. Parlar and D. Berkin, “Future supply uncertainty in EOQ models,” *Naval Research Logistics*, vol. 38, pp. 50–55, 1991.
- [11] M. Parlar and D. Perry, “Inventory models of future supply uncertainty with single and multiple suppliers,” *Naval Research Logistics*, vol. 43, pp. 191–210, 1996.
- [12] E. Mohebbi, “Supply interruptions in a lost-sales inventory system with random lead time,” *Computers and Operations Research*, vol. 30, pp. 824–835, 2003.
- [13] R. E. Bielecki and P. R. Kumar, “Optimality of zero inventory policies for unreliable manufacturing systems,” *Operations Research*, vol. 36, pp. 532–541, 1988.
- [14] G. Gallego, “Scheduling the production of several items with random demands in a single facility,” *Management Science*, vol. 36, pp. 1579–1592, 1990.
- [15] G. Gallego, “When is a base stock policy optimal in recovering disrupted cyclic schedules?,” *Naval Research Logistics*, vol. 41, pp. 317–333, 1994.
- [16] H. J. Weiss and E. C. Rosenthal, “Optimal ordering policies when anticipating a disruption in supply or demand,” *European Journal of Operational Research*, vol. 59, pp. 370–382, 1992.
- [17] H. Chao, “Inventory policy in the presence of market disruptions,” *Operations Research*, vol. 2, pp. 274–281, 1987.

- [18] M. Parlar, “Continuous-review inventory problem with random supply interruptions,” *European Journal of Operational Research*, vol. 99, pp. 366–385, 1997.
- [19] J. Song and P. Zipkin, “Inventory control with information about supply conditions,” *Management Science*, vol. 42, pp. 1409–1419, 1996.
- [20] T. J. Teisberg, “A dynamic programming model of the U.S. strategic petroleum reserve,” *Bell Journal of Economics*, vol. 12, pp. 526–546, 1981.
- [21] H. Chap and A. S. Manne, “An Integrated Analysis of U.S. Oil Stockpiling Policies,” Tech. Rep., Cambridge, MA: Ballinger Publishing Company, 1982.
- [22] F. H. Murphy, M. A. Toman, and H. J. Weiss, “A stochastic dynamic Nash game analysis of policies for managing the strategic petroleum reserves of consuming nations,” *Management Science*, vol. 33, no. 4, pp. 484–499, 1987.
- [23] M. J. Rosenblatt and H. L. Lee, “Economic production cycles with imperfect production processes,” *IIE Transactions*, vol. 18, pp. 48–55, 1986.
- [24] E. L. Porteus, “Optimal lot sizing, process quality improvement and setup cost reduction,” *Operations Research*, vol. 34, pp. 137–144, 1986.
- [25] H. L. Lee, “Lot sizing to reduce capacity utilization in a production process with defective items, process corrections, and rework,” *Management Science*, vol. 38, pp. 1314–1328, 1992.
- [26] N. E. Abboud, “A simple approximation of the EMQ model with poisson machine failures,” *Production Planning and Control*, vol. 8, pp. 385–397, 1997.
- [27] H. Groenevelt, A. Seidmann, and L. Pintelon, “Production lotsizing with machine breakdowns,” *Management Science*, vol. 38, pp. 104–123, 1992.



- [28] H. Groenevelt, A. Seidmann, and L. Pintelon, “Production batching with machine breakdowns and safety stocks,” *Operations Research*, vol. 40, pp. 959–971, 1992.
- [29] C. H. Kim and Y. Hong, “An extended EMQ model for a failure prone machine with general lifetime distribution,” *International Journal of Production Economics*, vol. 49, pp. 215–223, 1997.
- [30] W. J. Hopp, N. Pati, and P. C. Jones, “Optimal inventory control in a production flow system with failures,” *International Journal of Production Research*, vol. 27, pp. 1367–1384, 1989.
- [31] M. Henig and Y. Gerchak, “The structure of periodic review policies in the presence of random yield,” *Operations Research*, vol. 38, pp. 634–643, 1990.
- [32] J. A. Buzacott and J. G. Shantikumar, *Stochastic Models of Manufacturing Systems*, Englewood Cliffs, NJ: Prentice Hall, 1993.
- [33] K. Moinzadeh and P. Aggarwal, “Analysis of a production/inventory system subject to random disruptions,” *Management Science*, vol. 43, pp. 1577–1588, Nov. 1997.
- [34] N. E. Abboud, “A discrete-time markov production-inventory model with machine breakdowns,” *Computers & Industrial Engineering*, vol. 39, pp. 95–107, 2001.
- [35] M. A. Rahim, “Joint determination of production quantity, inspection schedule, and control chart design,” *IIE Transactions*, vol. 26, pp. 2–11, 1994.
- [36] E. Naddor, *Inventory Systems*, New York, NY: John Wiley & Sons, Inc., 1966.

- [37] S. G. Taylor and C. E. Bradley, “Optimal ordering strategies for announced price increases,” *Operations Research*, vol. 33, pp. 312–325, 1985.
- [38] R. L. Aull-Hyde, “Evaluation of supplier-restricted purchasing options under temporary price discounts,” *IIE Transactions*, vol. 24, pp. 184–186, 1992.
- [39] F. J. Arcelus and G. Srinivasan, “Discount strategies for one-time only sales,” *IIE Transactions*, vol. 27, pp. 618–624, 1995.
- [40] R. J. Tersine and S. Barman, “Economic purchasing strategies for temporary price discounts,” *European Journal of Operational Research*, vol. 80, pp. 328–343, 1995.
- [41] A. Ardalan, “A comparative analysis of approaches for determining optimal price and order quantity when a sale increases demand,” *European Journal of Operational Research*, vol. 84, pp. 416–430, 1995.
- [42] S.N. Dorogovtsev and J.F. Mendes, *Evolution of Networks : From Biological Nets to the Internet and WWW*, Oxford, Great Britain: Oxford University Press, 2003.
- [43] S. M. Ross, *Stochastic Processes*, New York, NY: John Wiley & Sons, Inc., 1996.

## VITA

Aliaksei Savachkin received a B.S. in industrial engineering from Belarussian State University of Informatics and Radioelectronics in 1996, and a M.S. in management of technology from the University of Colorado in 1998. He worked for several years in various industrial environments. His research interests lie in applied stochastic processes. He can be reached by contacting his advisor, Professor M. A. Wortman, Department of Industrial Engineering, Texas A&M University, College Station, TX 77843.