

**EFFECT OF ALKALINITY IN IRRIGATION WATER ON SELECTED  
GREENHOUSE CROPS**

A Dissertation

by

LUIS ALONSO VALDEZ AGUILAR

Submitted to the Office of Graduate Studies of  
Texas A&M University  
in partial fulfillment of the requirements for the degree of

DOCTOR OF PHILOSOPHY

August 2004

Major Subject: Horticulture

**EFFECT OF ALKALINITY IN IRRIGATION WATER ON SELECTED  
GREENHOUSE CROPS**

A Dissertation

by

LUIS ALONSO VALDEZ AGUILAR

Submitted to Texas A&M University  
in partial fulfillment of the requirements  
for the degree of

DOCTOR OF PHILOSOPHY

Approved as to style and content by:

---

David Wm. Reed  
(Chair of Committee)

---

H. Brent Pemberton  
(Member)

---

Frank M. Hons  
(Member)

---

Raul I. Cabrera  
(Member)

---

Tim Davis  
(Head of Department)

August 2004

Major Subject: Horticulture

## ABSTRACT

Effect of Alkalinity in Irrigation Water on Selected Greenhouse Crops. (August 2004)

Luis Alonso Valdez Aguilar, B.S., Universidad Autónoma de Nuevo León, Mexico;

M.S., Universidad Autónoma Chapingo, Mexico

Chair of Advisory Committee: Dr. David Wm. Reed

Bicarbonate ( $\text{HCO}_3^-$ ) and carbonate ( $\text{CO}_3^{2-}$ ) are the most important ions that determine alkalinity. When the carbonates accumulate in a growing medium, the growing medium solution pH reaches levels that cause plant growth inhibition, which is caused primarily by the transformation of soluble forms of Fe into insoluble forms.

The general objective of this research was to provide information about the limits of tolerance to alkalinity in ornamental plants, and to study the interaction of ions such as ammonium ( $\text{NH}_4^+$ ) and nitrate ( $\text{NO}_3^-$ ) on the response of plants to alkalinity, as well as the effect of the counter-ions potassium ( $\text{K}^+$ ), sodium ( $\text{Na}^+$ ), cesium ( $\text{Cs}^+$ ), ammonium ( $\text{NH}_4^+$ ) and rubidium ( $\text{Rb}^+$ ).

The maximum SPAD index was estimated to occur at 0 mM of  $\text{NaHCO}_3$  in chrysanthemum, mini-rose, and hibiscus 'Bimini Breeze' and 'Mango Breeze'. For vinca it was set at 2.64 mM. A 15% decrease from the maximum SPAD index was considered the threshold to declare the toxic concentration of  $\text{NaHCO}_3$ , which was calculated based on the maximum SPAD index predicted by the models.

The toxic concentration of  $\text{NaHCO}_3$  was set at 4.1, 1.1, 6.7, 3.1, and 6.3 mM of  $\text{NaHCO}_3$  in chrysanthemum, mini-rose, vinca, and hibiscus 'Mango Breeze' and 'Bimini Breeze', respectively. Hibiscus 'Bimini Breeze' was considered tolerant to alkalinity, due to increased Fe-reduction capacity and acidification of the growing medium.

In the hydroponic experiment, results showed that the  $\text{NH}_4^+:\text{NO}_3^-$  ratio altered the response of sunflower plants to alkalinity. Sunflower plants grew better in solutions containing 5 mM  $\text{NaHCO}_3$  prepared with a 0.25:0.75  $\text{NH}_4^+:\text{NO}_3^-$  ratio. This was possible due to the reaction of  $\text{NH}_4^+$  with the  $\text{HCO}_3^-$ , which reduced its buffering capacity.

The response to  $\text{HCO}_3^-$ -induced alkalinity was modified by the counter-cation of  $\text{HCO}_3^-$ . In bean plants, at low-to-intermediate levels of  $\text{Na}^+$  and  $\text{HCO}_3^-$  induced approximately same growth decrease. At high concentration,  $\text{Na}^+$  induced a decrease on shoot growth that exceeded the toxic effects of  $\text{HCO}_3^-$ . Thus, the toxic effect of  $\text{Na}^+$  is higher than that of  $\text{HCO}_3^-$  when its concentration is high. Rubidium was extremely toxic at concentrations of 7.5 mM.

## **DEDICATION**

I dedicate this dissertation to Juany, my wife, and Anakaren, my daughter. You girls have always been there for me, and you know I have you both deep in my mind and in my heart.

A very special dedication to my parents, Alonso and Angélica, for all they have represented in my life: honesty, dignity, dedication, perseverance, love, and religion.

This dissertation is also dedicated to my extended family: brothers and sisters, nieces and nephews. I also dedicate this dissertation to Rebeca, my mom in law, and all my numerous in-laws.

## ACKNOWLEDGEMENTS

I express my utmost gratitude to Dr. David Wm. Reed. Certainly his guidance determined the academic formation I received at Texas A&M University. His support and understanding at the beginning of my studies gave me the time I needed to get established in a country that looked so different than what I was used to. During difficulties, I know his intervention was important for me to overcome hard times.

I am also grateful to all my committee members: Dr. H. Brent Pemberton, Dr. Raul I. Cabrera, and Dr. Frank M. Hons. Thanks for all the advice, the thorough review of my proposal and dissertation, and the constructive criticism.

I thank Dr. Frank Hons for his permission to work in his laboratory to analyze nutrient solutions.

My sincere gratitude goes to Matthew Kent, senior research assistant. Thanks for the suggestions and for bringing up the experiments with mixtures to Dr. Reed's lab. I also thank you for your technical assistance in the experiments executed.

Thanks to Paul Greer and Dr. Chuanjiu He for the help to solve all my problems with computers and hydroponic experiments.

Special thanks to Dr. Michael A. Arnold, Mr. Jim Johnson, and Dr. Richard White for the support during the Fall of 2003, when all seemed to be over.

My gratitude also goes to Andrew Cartmill, Donita Bryan, Trisha Blessington, Carrie Whitcher, Alejandro Alarcon, Alma Solis, and Lucila Carpio. Special thanks to Laura and Jeremy Burton.

I express my gratitude to México, for the financial support through the National Council of Science and Technology (CONACYT) and the Department of Fitotecnia of the Universidad Autónoma Chapingo.

## TABLE OF CONTENTS

	Page
ABSTRACT.....	iii
DEDICATION.....	v
ACKNOWLEDGEMENTS.....	vi
TABLE OF CONTENTS.....	vii
LIST OF TABLES.....	xiii
LIST OF FIGURES.....	xx
CHAPTER	
I INTRODUCTION.....	1
Alkalinity Levels in Texas Water.....	2
Chemistry of the Carbonates.....	2
Relationship between Alkalinity, $\text{HCO}_3^-$ , and pH.....	7
Other Factors That Increase Alkalinity.....	7
Direct and Indirect Effects of Alkalinity on Plants.....	8
Leaf Chlorosis and Alkalinity.....	9
Alkalinity and Irrigation Water in Greenhouse Crops.....	11
II LITERATURE REVIEW.....	12
Effect of $\text{HCO}_3^-$ on Plant Growth.....	12
Is There a Signal to Detect $\text{HCO}_3^-$ Stress?.....	14
Iron Uptake and Accumulation.....	14
Effect of $\text{HCO}_3^-$ on Tissue Concentration of Fe.....	14
Bicarbonate and Fe Chlorosis: the Chlorosis Paradox.....	15
Bicarbonate and Root and Leaf Apoplastic pH.....	16
Bicarbonate and Fe-Reduction Capacity.....	17
Plant Responses to Fe Deficiency.....	19
Strategy I.....	19
Strategy II.....	20
Effect of $\text{HCO}_3^-$ on Plant Nutrition.....	20
Nitrogen.....	21

CHAPTER	Page
Potassium.....	21
Phosphorus.....	21
Calcium.....	22
Magnesium.....	22
Zinc.....	22
Other Micronutrients.....	23
Interaction between Sodium and Alkaline pH .....	23
Uptake of HCO <sub>3</sub> <sup>-</sup> and CO <sub>2</sub> by Roots.....	23
 III DETERMINATION OF TOLERANCE AND TOXICITY ALKALINITY LIMITS IN SELECTED GREENHOUSE ORNAMENTAL PLANTS.....	24
Introduction.....	24
Materials and Methods.....	26
Results and Discussion.....	29
Chrysanthemum.....	29
Rose.....	36
Vinca.....	41
Hibiscus.....	45
Conclusions.....	53
 IV RESPONSE OF TWO CULTIVARS OF HIBISCUS ( <i>Hibiscus rosa-sinensis</i> L. ) TO ALKALINITY IN IRRIGATION WATER...	54
Introduction.....	54
Materials and Methods.....	54
Experiment 4.1. Determination of Tolerance and Toxic Limits of Alkalinity of Hibiscus Grown in Sphagnum Peat-Based Growing Medium.....	54
Experiment 4.2. Determination of Tolerance and Toxic Limits of Alkalinity of Hibiscus Grown in Hydroponics.....	56
Results.....	58
Experiment 4.1. Determination of Tolerance and Toxic Limits of Alkalinity of Hibiscus Grown in Sphagnum Peat-Based Growing Medium.....	58
Shoot growth.....	58
Root growth.....	64
Shoot:root ratio.....	64
Growing medium pH.....	67
SPAD index.....	67



CHAPTER	Page
	Toxic concentrations of NaHCO <sub>3</sub> ..... 67
	Experiment 4.2. Determination of Tolerance and Toxic Limits of Alkalinity in Hibiscus in Hydroponics..... 70
	General appearance..... 70
	Shoot growth..... 70
	Root growth..... 70
	Shoot:root ratio..... 74
	Solution pH..... 74
	Fe-reductase activity..... 76
	SPAD index..... 76
	Discussion..... 76
	Shoot Growth..... 76
	Root Growth..... 80
	Growing Medium and Solution pH..... 81
	SPAD Index and Fe-Reductase Activity..... 82
	Conclusions..... 83
V	EFFECT OF NO <sub>3</sub> <sup>-</sup> : NH <sub>4</sub> <sup>+</sup> RATIO IN THE RESPONSE OF SUNFLOWER ( <i>Helianthus annuus</i> L. 'Big Smile') TO ALKALINITY IN HYDROPONICS..... 84
	Introduction..... 84
	Materials and Methods..... 85
	Results..... 86
	Solution pH..... 86
	Shoot Height and Number of Leaves..... 88
	Total and Root Dry Mass..... 93
	Shoot:Root Ratio..... 93
	Discussion..... 93
	Effect of the NO <sub>3</sub> <sup>-</sup> : NH <sub>4</sub> <sup>+</sup> Ratio..... 93
	The Interaction of NaHCO <sub>3</sub> and NO <sub>3</sub> <sup>-</sup> : NH <sub>4</sub> <sup>+</sup> Ratio..... 97
	Conclusions..... 99
VI	EFFECT OF COUNTER-IONS OF BICARBONATE ON BEAN ( <i>Phaseolus vulgaris</i> L.) 'Poncho' GROWN IN HYDROPONICS..... 100
	Introduction..... 100
	Materials and Methods..... 104

	Page
Experiment 6.1. Effect of Mixtures of $\text{Na}^+$ , $\text{K}^+$ , and $\text{NH}_4^+$ on the Response of Bean Plants to $\text{HCO}_3^-$ .....	104
Experiment 6.2. Effect of Mixtures of $\text{Na}^+$ , $\text{K}^+$ , and $\text{Cs}^+$ on the Response of Bean Plants to $\text{HCO}_3^-$ .....	105
Experiment 6.3. Effect of Mixtures of $\text{Rb}^+$ , $\text{K}^+$ , and $\text{Na}^+$ on the Response of Bean Plants to $\text{HCO}_3^-$ .....	108
Experiment 6.4. Effect of Mixtures of $\text{Rb}^+$ , $\text{K}^+$ , and $\text{Na}^+$ on the Response of Bean Plants to $\text{HCO}_3^-$ .....	111
Experiment 6.5. Response of Bean Plants to Alkalinity Induced by $\text{NaHCO}_3$ and $\text{KHCO}_3$ .....	111
Experiment 6.6. Effect of the $\text{K}^+:\text{Na}^+$ Binary Mixtures on the Response of Bean Plants to $\text{HCO}_3^-$ .....	113
Results.....	117
Experiment 6.1. Effect of Mixtures of $\text{Na}^+$ , $\text{K}^+$ , and $\text{NH}_4^+$ on the Response of Bean Plants to $\text{HCO}_3^-$ .....	117
Shoot and root mass.....	117
Models.....	117
Pure blends (vertices).....	117
Coordinates (0% to 100% blends).....	117
Binary blends (50%:50% blends).....	122
Optimization.....	122
Leaf growth.....	122
Shoot:root ratio.....	125
Total chlorophyll.....	125
Solution final pH.....	127
Discussion.....	127
Shoot growth.....	127
Root growth and total chlorophyll concentration.....	130
Conclusions.....	131
Experiment 6.2. Effect of Mixtures of $\text{Na}^+$ , $\text{K}^+$ , and $\text{Cs}^+$ on the Response of Bean Plants to $\text{HCO}_3^-$ .....	131
Experiment 6.3. Effect of Mixtures of $\text{Rb}^+$ , $\text{K}^+$ , and $\text{Na}^+$ on the Response of Bean Plants to $\text{HCO}_3^-$ .....	132
Shoot and root mass .....	132
0 mM $\text{HCO}_3^-$ .....	132
7.5 mM $\text{HCO}_3^-$ .....	138

	Page
Leaf growth.....	140
Shoot:root ratio.....	140
Total chlorophyll.....	145
Solution final pH.....	145
Water consumption.....	147
K <sup>+</sup> tissue concentration.....	147
Discussion.....	150
Conclusions.....	153
Experiment 6.4. Effect of Mixtures of Rb <sup>+</sup> , K <sup>+</sup> , and Na <sup>+</sup> on the Response of Bean Plants to HCO <sub>3</sub> <sup>-</sup> .....	157
Shoot and root mass.....	157
0 mM HCO <sub>3</sub> <sup>-</sup> .....	157
7.5 mM HCO <sub>3</sub> <sup>-</sup> .....	163
Leaf growth.....	164
Shoot:root ratio.....	164
Total chlorophyll.....	170
Solution final pH.....	170
Discussion.....	172
Experiment 6.5. Response of Bean Plants to Alkalinity Induced by NaHCO <sub>3</sub> and KHCO <sub>3</sub> .....	173
Shoot and root mass.....	173
Leaf growth.....	176
Total chlorophyll.....	176
Discussion.....	176
Experiment 6.6. Effect of K <sup>+</sup> :Na <sup>+</sup> Binary Mixtures on the Response of Bean Plants to HCO <sub>3</sub> <sup>-</sup> .....	178
Shoot mass.....	178
2.5 mM total mixture.....	178
5 mM total mixture.....	184
7.5 mM total mixture.....	189
Root mass.....	194
2.5 and 5 mM total mixture.....	194
7.5 mM total mixture.....	194
Shoot:root ratio.....	196
Leaf growth.....	196
Total chlorophyll.....	204
Solution final pH.....	204
Water consumption.....	212
K <sup>+</sup> and Na <sup>+</sup> net uptake.....	212
Discussion.....	212
Shoot growth.....	212

CHAPTER	Page
2.5 mM total mixture .....	212
5 mM total mixture.....	218
7.5 mM total mixture.....	219
Root growth.....	220
Effect of $\text{HCO}_3^-$ in the $\text{K}^+$ and $\text{Na}^+$ uptake.....	220
Water uptake.....	221
Shoot:root ratio.....	222
Conclusions.....	222
Summary.....	223
VII SUMMARY.....	226
Tolerance to Alkalinity in Selected Greenhouse Plants.....	226
Response of Two Cultivars of Hibiscus to Alkalinity in Irrigation Water.....	227
Effect of the $\text{NO}_3^-$ : $\text{NH}_4^+$ Ratio in the Response of Sunflower to Alkalinity.....	229
Effect of Counter-ions of Bicarbonate on Bean Plants.....	230
LITERATURE CITED.....	232
APPENDIX.....	245
VITA.....	265

## LIST OF TABLES

TABLE	Page
3.1. Recommended concentrations of alkalinity, as $\text{HCO}_3^-$ , for irrigation of ornamental plants.....	25
3.2. Effect of the concentration of $\text{NaHCO}_3$ in irrigation water on shoot growth parameters, SPAD index, and growing medium pH of <i>Chrysanthemum morifolium</i> Ramat ‘Miramar’.....	32
3.3. Estimated maximum shoot dry mass and SPAD index and optimum and toxic concentrations of $\text{NaHCO}_3$ in irrigation water of <i>Chrysanthemum morifolium</i> Ramat ‘Miramar’, <i>Rosa</i> sp. L. ‘Pink Cupido’, <i>Catharanthus roseus</i> (L.) G. Don ‘Apricot Delight’, and <i>Hibiscus rosa-sinensis</i> L. ‘Mango Breeze’ and ‘Bimini Breeze’. Optimum concentration defined as the concentration at the maximum shoot dry mass or SPAD index when ANOVA was significant; toxic concentration defined as the concentration at 15% reduction for shoot dry mass or SPAD index.....	35
3.4. Effect of the concentration of $\text{NaHCO}_3$ in irrigation water on shoot growth parameters, SPAD index, and growing medium pH of <i>Rosa</i> sp. L. ‘Pink Cupido’.....	37
3.5. Effect of the concentration of $\text{NaHCO}_3$ in irrigation water on shoot growth parameters, SPAD index, and growing medium pH of <i>Catharanthus roseus</i> (L.) G. Don ‘Apricot Delight’.....	42
3.6. Effect of the concentration of $\text{NaHCO}_3$ in irrigation water on shoot growth parameters, SPAD index, and growing medium pH of <i>Hibiscus rosa-sinensis</i> L. ‘Mango Breeze’.....	47
3.7. Effect of the concentration of $\text{NaHCO}_3$ in irrigation water on shoot growth parameters, SPAD index, and growing medium pH of <i>Hibiscus rosa-sinensis</i> L. ‘Bimini Breeze’.....	48
4.1. Effect of the concentration of $\text{NaHCO}_3$ (mM) in irrigation water on growth parameters of <i>Hibiscus rosa-sinensis</i> L. ‘Bimini Breeze’ (BB) and ‘Carolina Breeze’ (CB).....	60
4.2. Effect of the concentration of $\text{NaHCO}_3$ (mM) in irrigation water on SPAD index and growth parameters of <i>Hibiscus rosa-sinensis</i> L. ‘Bimini Breeze’ (BB) and ‘Carolina Breeze’ (CB). .....	63

TABLE	Page
4.3. Effect of the concentration of $\text{NaHCO}_3$ (mM) in irrigation water on root growth parameters and growing medium pH of the top, middle, and bottom layer of <i>Hibiscus rosa-sinensis</i> L. ‘Bimini Breeze’ (BB) and ‘Carolina Breeze’ (CB). .....	66
4.4. Estimated maximum shoot dry mass, root dry mass, and SPAD index, and optimum and toxic concentration of $\text{NaHCO}_3$ . Optimum concentration defined as the concentration at the maximum shoot dry mass or SPAD index when ANOVA was significant; toxic concentration defined as the concentration at 15% reduction for shoot dry mass or SPAD index.....	69
4.5. Effect of the concentration of $\text{NaHCO}_3$ (mM) in nutrient solution on shoot and root growth parameters of <i>Hibiscus rosa-sinensis</i> L. ‘Bimini Breeze’ (BB) and ‘Carolina Breeze’ (CB).....	72
4.6. Effect of the concentration of $\text{NaHCO}_3$ (mM) in nutrient solution on root growth parameters and Fe-reductase activity of <i>Hibiscus rosa-sinensis</i> L. ‘Bimini Breeze’ (BB) and ‘Carolina Breeze’ (CB). .....	73
6.1. Mixtures utilized for Experiment 6.1 indicating respective proportion and concentration of counter-cations.....	106
6.2. Mixtures utilized for Experiment 6.2 indicating respective proportion and concentration of counter-cations and $\text{HCO}_3^-$ . .....	109
6.3. Mixtures utilized for Experiment 6.3 indicating respective proportion and concentration of counter-cations and $\text{HCO}_3^-$ . .....	110
6.4. Resulting pH and EC for the $\text{NaHCO}_3$ and $\text{KHCO}_3$ concentrations evaluated.....	112
6.5. Mixtures utilized for Experiment 6.6 indicating respective proportion and concentration of counter-cations, $\text{HCO}_3^-$ . .....	116
6.6. Effect of mixtures of varying proportions of $\text{NH}_4^+$ , $\text{K}^+$ , and $\text{Na}^+$ counter-cations of $\text{HCO}_3^-$ on shoot, root, and leaf growth parameters of bean, <i>Phaseolus vulgaris</i> L. ‘Poncho’, plants grown in hydroponics with a 5 mM total concentration. Experiment 6.1 .....	118
6.7. Models <sup>z</sup> for the shoot, root, and leaf growth parameters of bean, <i>Phaseolus vulgaris</i> L. ‘Poncho’, plants in response to $\text{NH}_4^+:\text{K}^+:\text{Na}^+$ mixtures with a 5 mM total concentration. Experiment 6.1.....	119

TABLE	Page
6.8. Predicted response and 95% confidence interval for some growth parameters evaluated of bean, <i>Phaseolus vulgaris</i> L. 'Poncho', plants grown in mixtures of varying proportions of $\text{NH}_4^+$ , $\text{K}^+$ , and $\text{Na}^+$ counter-cations of $\text{HCO}_3^-$ in hydroponics with a 5 mM total concentration. Experiment 6.1.....	121
6.9. Effect of mixtures of varying proportions of $\text{NH}_4^+$ , $\text{K}^+$ , and $\text{Na}^+$ counter-cations of $\text{HCO}_3^-$ on leaf area, leaf number, shoot:root ratio, solution pH, and total chlorophyll concentration of bean, <i>Phaseolus vulgaris</i> L. 'Poncho', plants grown in hydroponics with a 5 mM total concentration. Experiment 6.1.....	123
6.10. Models <sup>z</sup> for leaf area, leaf number, shoot:root ratio, solution pH, and total chlorophyll concentration of bean, <i>Phaseolus vulgaris</i> L. 'Poncho', plants in response to $\text{NH}_4^+:\text{K}^+:\text{Na}^+$ mixtures with a 5 mM total concentration. Experiment 6.1.....	124
6.11. Effect of mixtures of varying proportions of $\text{Rb}^+$ , $\text{K}^+$ , and $\text{Na}^+$ counter-cations of $\text{HCO}_3^-$ on shoot, root, and leaf growth parameters of bean, <i>Phaseolus vulgaris</i> L. 'Poncho', plants grown in hydroponics with a 7.5 mM total concentration and two levels of $\text{HCO}_3^-$ . Experiment 6.3.....	133
6.12. Models <sup>z</sup> for the shoot, root, and leaf growth parameters of bean, <i>Phaseolus vulgaris</i> L. 'Poncho', plants in response to $\text{Rb}^+:\text{K}^+:\text{Na}^+$ mixtures with a 7.5 mM total concentration combined with two concentrations of $\text{HCO}_3^-$ . Experiment 6.3.....	134
6.13. Final equations for the growth parameters of bean, <i>Phaseolus vulgaris</i> L. 'Poncho', plants in response to $\text{Rb}^+:\text{K}^+:\text{Na}^+$ mixtures with a 7.5 mM total concentration combined with two concentrations of $\text{HCO}_3^-$ . Experiment 6.3.....	137
6.14. Predicted response and 95% confidence interval for growth parameters evaluated of bean, <i>Phaseolus vulgaris</i> L. 'Poncho', plants grown in mixtures of varying proportions of $\text{Rb}^+$ , $\text{K}^+$ , and $\text{Na}^+$ counter-cations of $\text{HCO}_3^-$ with 7.5 mM total concentration and two concentrations of $\text{HCO}_3^-$ . Experiment 6.3.....	139

TABLE	Page
6.15. Effect of mixtures of varying proportions of $\text{Rb}^+$ , $\text{K}^+$ , and $\text{Na}^+$ counter-cations of $\text{HCO}_3^-$ on leaf area, shoot:root ratio, solution pH, total chlorophyll concentration, and water consumption of bean, <i>Phaseolus vulgaris</i> L. ‘Poncho’, plants grown in hydroponics with a 7.5 mM total concentration and two levels of $\text{HCO}_3^-$ . Experiment 6.3.....	141
6.16. Models <sup>z</sup> for leaf area, shoot:root ratio, solution pH, total chlorophyll concentration, and water consumption of bean, <i>Phaseolus vulgaris</i> L. ‘Poncho’, plants in response to $\text{Rb}^+:\text{K}^+:\text{Na}^+$ mixtures with a 7.5 mM total concentration combined with two concentrations of $\text{HCO}_3^-$ . Experiment 6.3.....	142
6.17. Percentage decrease in shoot dry mass due to the effect of the counter-cations, $\text{HCO}_3^-$ , and interactions. Experiment 6.3.....	153
6.18. Effect of mixtures of varying proportions of $\text{Rb}^+$ , $\text{K}^+$ , and $\text{Na}^+$ counter-cations of $\text{HCO}_3^-$ on shoot, root, and leaf growth parameters of bean, <i>Phaseolus vulgaris</i> L. ‘Poncho’, plants grown in hydroponics with a 7.5 mM total concentration and two levels of $\text{HCO}_3^-$ . Experiment 6.4.....	158
6.19. Models <sup>z</sup> for the shoot, root, and leaf growth parameters of bean, <i>Phaseolus vulgaris</i> L. ‘Poncho’, plants in response to $\text{Rb}^+:\text{K}^+:\text{Na}^+$ mixtures with a 7.5 mM total concentration combined with two concentrations of $\text{HCO}_3^-$ . Experiment 6.4.....	159
6.20. Predicted response and 95% confidence interval for growth parameters evaluated of bean, <i>Phaseolus vulgaris</i> L. ‘Poncho’, plants grown in mixtures of varying proportions of $\text{Rb}^+$ , $\text{K}^+$ , and $\text{Na}^+$ counter-cations of $\text{HCO}_3^-$ with 7.5 mM total concentration and two concentrations of $\text{HCO}_3^-$ . Experiment 6.4.....	162
6.21. Final equations for the growth parameters of bean, <i>Phaseolus vulgaris</i> L. ‘Poncho’ plants, in response to $\text{Rb}^+:\text{K}^+:\text{Na}^+$ mixtures with a 7.5 mM total concentration combined with two concentrations of $\text{HCO}_3^-$ . Experiment 6.4.....	165
6.22. Effect of mixtures of varying proportions of $\text{Rb}^+$ , $\text{K}^+$ , and $\text{Na}^+$ counter-cations of $\text{HCO}_3^-$ on leaf area, leaf number, shoot:root ratio, solution pH, and total chlorophyll concentration of bean, <i>Phaseolus vulgaris</i> L. ‘Poncho’, plants grown in hydroponics with a 7.5 mM total concentration and two levels of $\text{HCO}_3^-$ . Experiment 6.4.....	166



TABLE	Page
6.23. Models <sup>2</sup> for leaf area, leaf number, shoot:root ratio, solution pH, and total chlorophyll concentration of bean, <i>Phaseolus vulgaris</i> L. 'Poncho', plants in response to Rb <sup>+</sup> :K <sup>+</sup> :Na <sup>+</sup> mixtures with a 7.5 mM total concentration combined with two concentrations of HCO <sub>3</sub> <sup>-</sup> . Experiment 6.4.....	169
6.24. Effect of the concentration of two sources of bicarbonate, NaHCO <sub>3</sub> and KHCO <sub>3</sub> , on shoot and root mass of bean, <i>Phaseolus vulgaris</i> L. 'Poncho', plants grown in hydroponics. Experiment 6.5.....	174
6.25. Effect of the concentration of two sources of bicarbonate, NaHCO <sub>3</sub> and KHCO <sub>3</sub> , on leaf area, leaf dry and fresh mass, final solution pH, and total chlorophyll concentration of bean, <i>Phaseolus vulgaris</i> L. 'Poncho', plants grown in hydroponics. Experiment 6.5.....	177
6.26. Effect of mixtures of varying proportions of K <sup>+</sup> and Na <sup>+</sup> counter-cations of HCO <sub>3</sub> <sup>-</sup> on shoot and root mass of bean, <i>Phaseolus vulgaris</i> L. 'Poncho', plants in a 2.5 mM total concentration and two levels of HCO <sub>3</sub> <sup>-</sup> . Experiment 6.6.....	179
6.27. Models <sup>2</sup> for the shoot and root mass, shoot:root ratio, and leaf area of bean, <i>Phaseolus vulgaris</i> L. 'Poncho', plants in response to K <sup>+</sup> :Na <sup>+</sup> mixtures with a 2.5 mM total concentration combined with two concentrations of HCO <sub>3</sub> <sup>-</sup> . Experiment 6.6.....	180
6.28. Final equation for the growth parameters of bean, <i>Phaseolus vulgaris</i> L. 'Poncho', plants in response to K <sup>+</sup> :Na <sup>+</sup> mixtures with a 2.5 mM total concentration combined with two concentrations of HCO <sub>3</sub> <sup>-</sup> . Experiment 6.6.....	181
6.29. Predicted response and 95% confidence interval for shoot mass, root mass, and leaf area of bean, <i>Phaseolus vulgaris</i> L. 'Poncho' plants, grown in mixtures of varying proportions of K <sup>+</sup> and Na <sup>+</sup> counter-cations of HCO <sub>3</sub> <sup>-</sup> with a 2.5 mM total concentration and two concentrations of HCO <sub>3</sub> <sup>-</sup> . Experiment 6.6.....	183
6.30. Effect of mixtures of varying proportions of K <sup>+</sup> and Na <sup>+</sup> counter-cations of HCO <sub>3</sub> <sup>-</sup> on shoot and root mass of bean, <i>Phaseolus vulgaris</i> L. 'Poncho' plants, in a 5 mM total concentration and two levels of HCO <sub>3</sub> <sup>-</sup> . Experiment 6.6.....	185

TABLE	Page
6.31. Models <sup>z</sup> for the shoot and root mass, shoot:root ratio, and leaf area of bean, <i>Phaseolus vulgaris</i> L. 'Poncho', plants in response to a 5 mM mixture of varying proportions of K <sup>+</sup> and Na <sup>+</sup> combined with two concentrations of HCO <sub>3</sub> <sup>-</sup> . Experiment 6.6.....	186
6.32. Final equation for the growth parameters of bean, <i>Phaseolus vulgaris</i> L. 'Poncho', plants in response to K <sup>+</sup> :Na <sup>+</sup> mixtures with a 5 mM total concentration combined with two concentrations of HCO <sub>3</sub> <sup>-</sup> . Experiment 6.6.....	187
6.33. Predicted response and 95% confidence interval for shoot mass, root mass, and leaf area of bean, <i>Phaseolus vulgaris</i> L. 'Poncho', plants grown in mixtures of varying proportions of K <sup>+</sup> and Na <sup>+</sup> counter-cations of HCO <sub>3</sub> <sup>-</sup> with a 5 mM total concentration and two concentrations of HCO <sub>3</sub> <sup>-</sup> . Experiment 6.6.....	188
6.34. Effect of mixtures of varying proportions of K <sup>+</sup> and Na <sup>+</sup> counter-cations of HCO <sub>3</sub> <sup>-</sup> on shoot and root mass of bean, <i>Phaseolus vulgaris</i> L. 'Poncho', plants in a 7.5 mM total concentration and two levels of HCO <sub>3</sub> <sup>-</sup> . Experiment 6.6.....	190
6.35. Models <sup>z</sup> for the shoot and root mass, shoot:root ratio, and leaf area of bean, <i>Phaseolus vulgaris</i> L. 'Poncho' plants in response to K <sup>+</sup> :Na <sup>+</sup> mixtures with a 7.5 mM total concentration combined with two concentrations of HCO <sub>3</sub> <sup>-</sup> . Experiment 6.6.....	191
6.36. Final equation for the growth parameters of bean, <i>Phaseolus vulgaris</i> L. 'Poncho', plants in response to K <sup>+</sup> :Na <sup>+</sup> mixtures with a 7.5 mM total concentration combined with two concentrations of HCO <sub>3</sub> <sup>-</sup> . Experiment 6.6.....	192
6.37. Predicted response and 95% confidence interval for shoot mass, root mass, and leaf area of bean, <i>Phaseolus vulgaris</i> L. 'Poncho', plants grown in mixtures of varying proportions of K <sup>+</sup> and Na <sup>+</sup> counter-cations of HCO <sub>3</sub> <sup>-</sup> with a 7.5 mM total concentration and two concentrations of HCO <sub>3</sub> <sup>-</sup> . Experiment 6.6.....	193
6.38. Effect of mixtures of varying proportions of K <sup>+</sup> and Na <sup>+</sup> counter-cations of HCO <sub>3</sub> <sup>-</sup> on shoot:root ratio and leaf growth parameters of bean, <i>Phaseolus vulgaris</i> L. 'Poncho', plants in a 2.5 mM total concentration and two levels of HCO <sub>3</sub> <sup>-</sup> . Experiment 6.6.....	197

TABLE	Page
6.39. Effect of mixtures of varying proportions of $K^+$ and $Na^+$ counter-cations of $HCO_3^-$ on shoot:root ratio and leaf growth parameters of bean, <i>Phaseolus vulgaris</i> L. 'Poncho', plants in a 5 mM total concentration and two levels of $HCO_3^-$ . Experiment 6.6.....	198
6.40. Effect of mixtures of varying proportions of $K^+$ and $Na^+$ counter-cations of $HCO_3^-$ on shoot:root ratio and leaf growth parameters of bean, <i>Phaseolus vulgaris</i> L. 'Poncho', plants in a 7.5 mM total concentration and two levels of $HCO_3^-$ . Experiment 6.6.....	199
6.41. Models <sup>z</sup> for leaf mass, solution pH, total chlorophyll concentration, and water consumption of bean, <i>Phaseolus vulgaris</i> L. 'Poncho', plants in response to $K^+ : Na^+$ mixtures with a 2.5 mM total concentration combined with two concentrations of $HCO_3^-$ . Experiment 6.6.....	201
6.42. Models <sup>z</sup> for leaf mass, solution pH, total chlorophyll concentration, and water consumption of bean, <i>Phaseolus vulgaris</i> L. 'Poncho', plants in response to $K^+ : Na^+$ mixtures with a 5 mM total concentration combined with two concentrations of $HCO_3^-$ . Experiment 6.6.....	202
6.43. Models <sup>z</sup> for leaf mass, solution pH, total chlorophyll concentration, and water consumption of bean, <i>Phaseolus vulgaris</i> L. 'Poncho', plants in response to $K^+ : Na^+$ mixtures with a 7.5 mM total concentration combined with two concentrations of $HCO_3^-$ . Experiment 6.6.....	203
6.44. Effect of mixtures of varying proportions of $K^+$ and $Na^+$ counter-cations of $HCO_3^-$ on solution pH, total chlorophyll concentration, and water consumption of bean, <i>Phaseolus vulgaris</i> L. 'Poncho', plants in a 2.5 mM total concentration and two levels of $HCO_3^-$ . Experiment 6.6.....	205
6.45. Effect of mixtures of varying proportions of $K^+$ and $Na^+$ counter-cations of $HCO_3^-$ on solution pH, total chlorophyll concentration, and water consumption of bean, <i>Phaseolus vulgaris</i> L. 'Poncho', plants in a 5 mM total concentration and two levels of $HCO_3^-$ . Experiment 6.6.....	206
6.46. Effect of mixtures of varying proportions of $K^+$ and $Na^+$ counter-cations of $HCO_3^-$ on solution pH, total chlorophyll concentration, and water consumption of bean, <i>Phaseolus vulgaris</i> L. 'Poncho', plants in a 7.5 mM total concentration and two levels of $HCO_3^-$ . Experiment 6.6.....	207

TABLE	Page
6.47. Predicted response and 95% confidence interval for leaf mass, total chlorophyll concentration, and water consumption of bean, <i>Phaseolus vulgaris</i> L. ‘Poncho’, plants grown in mixtures of varying proportions of $K^+$ and $Na^+$ counter-cations of $HCO_3^-$ with a 2.5 mM total concentration and two concentrations of $HCO_3^-$ . Experiment 6.6.....	209
6.48. Predicted response and 95% confidence interval for leaf mass, total chlorophyll concentration, and water consumption of bean, <i>Phaseolus vulgaris</i> L. ‘Poncho’, plants grown in mixtures of varying proportions of $K^+$ and $Na^+$ counter-cations of $HCO_3^-$ with a 5 mM total concentration and two concentrations of $HCO_3^-$ . Experiment 6.6.....	210
6.49. Predicted response and 95% confidence interval for leaf mass, total chlorophyll concentration, and water consumption of bean, <i>Phaseolus vulgaris</i> L. ‘Poncho’, plants grown in mixtures of varying proportions of $K^+$ and $Na^+$ counter-cations of $HCO_3^-$ with a 7.5 mM total concentration and two concentrations of $HCO_3^-$ . Experiment 6.6.....	211
6.50. Percentage decrease in shoot dry mass due to the effect of the counter-cations, $HCO_3^-$ , and interactions. Experiment 6.6.....	215
6.51. Summary of the percentage decrease in shoot dry mass due to the effect of the counter-cations, $HCO_3^-$ , and interactions.....	225

## LIST OF FIGURES

FIGURE	Page
1.1 Distribution of three classes of water reservoirs in Texas according to Ground and Groeger (1994).....	3
1.2. Effect of the solution pH on the proportion of the carbonate species. Adapted from Lindsay (1979).....	6
1.3. Effect of solution pH on the activity of carbonate species in equilibrium with 0.0003 atm of CO <sub>2</sub> . Adapted from Lindsay (1979).....	6
1.4. Effect of pH on the activity of Fe forms and other nutrients. Adapted from Barber, 1999.....	9
3.1. Effect of the concentration of NaHCO <sub>3</sub> in irrigation water on plant growth of (TOP) <i>Chrysanthemum morifolium</i> Ramat 'Miramar' (A), <i>Rosa</i> sp. L. 'Pink Cupido' (B), <i>Catharanthus roseus</i> 'Apricot Delight' (C), and (BOTTOM) <i>Hibiscus rosa-sinensis</i> L. 'Mango Breeze' (D) and 'Bimini Breeze' (E).....	30
3.2. Effect of the concentration of NaHCO <sub>3</sub> in irrigation water on root growth of <i>Chrysanthemum morifolium</i> Ramat 'Miramar' (A), <i>Rosa</i> sp L. 'Pink Cupido' (B), <i>Catharanthus roseus</i> 'Apricot Delight' (C), and <i>Hibiscus rosa-sinensis</i> L. 'Mango Breeze' (D) and 'Bimini Breeze' (E). Left column is for control plants, right column is for plants irrigated with 10 mM NaHCO <sub>3</sub> .....	31
3.3. Plant height of <i>Chrysanthemum morifolium</i> Ramat 'Miramar' plants irrigated with increasing concentrations of NaHCO <sub>3</sub> (mM). Bars represent standard error for the mean (n=5).....	33
3.4. SPAD index at final harvest of <i>Chrysanthemum morifolium</i> Ramat 'Miramar' plants irrigated with increasing concentrations of NaHCO <sub>3</sub> (mM). Bars represent standard error for the mean (n=5). LSD is the minimum significant difference at $P \leq 0.05$ .....	34
3.5. Plant height of <i>Rosa</i> sp L. 'Pink Cupido' plants irrigated with increasing concentrations of NaHCO <sub>3</sub> (mM). Bars represent standard error for the mean (n=5).....	38
3.6. SPAD index at final harvest of <i>Rosa</i> sp L. 'Pink Cupido' plants irrigated with increasing concentrations of NaHCO (mM). Bars represent standard error for the mean (n=5). LSD is the minimum significant difference at $P \leq 0.05$ .....	40

FIGURE	Page
3.7. Plant height of <i>Catharanthus roseus</i> (L.) G. Don 'Apricot Delight' plants irrigated with increasing concentrations of NaHCO <sub>3</sub> (mM). Bars represent standard error for the mean (n=5).....	43
3.8. SPAD index at final harvest of <i>Catharanthus roseus</i> (L.) G. Don 'Apricot Delight' plants irrigated with increasing concentrations of NaHCO <sub>3</sub> (mM). Bars represent standard error for the mean (n=5). LSD is the minimum significant difference at $P \leq 0.05$ .....	44
3.9. Plant height of <i>Hibiscus rosa-sinensis</i> L. 'Mango Breeze' (A) and 'Bimini Breeze' (B) irrigated with increasing concentrations of NaHCO <sub>3</sub> (mM). Bars are the standard error of the mean (n=5).....	49
3.10. SPAD index at final harvest of <i>Hibiscus rosa-sinensis</i> L. 'Mango Breeze' and 'Bimini Breeze' irrigated with increasing concentrations of NaHCO <sub>3</sub> (mM). Bars represent standard error for the mean (n=5). LSD BB and LSD MB are the minimum significant difference at $P \leq 0.05$ for hibiscus 'Bimini Breeze' and 'Mango Breeze', respectively.....	50
4.1. Effect of the concentration of NaHCO <sub>3</sub> in irrigation water on general appearance of <i>Hibiscus rosa-sinensis</i> L. 'Bimini Breeze' (left) and 'Carolina Breeze' (right).....	59
4.2. Shoot height of <i>Hibiscus rosa-sinensis</i> L. 'Bimini Breeze' (A) and 'Carolina Breeze' (B) plants irrigated with increasing concentrations of NaHCO <sub>3</sub> (mM). Bars represent standard error for the mean (n=5).....	61
4.3. Number of leaves at final harvest of <i>Hibiscus rosa-sinensis</i> L. 'Bimini Breeze' (A) and 'Carolina Breeze' (B) plants irrigated with increasing concentration of NaHCO <sub>3</sub> (mM). Bars represent standard error for the mean (n=5).....	62
4.4. Effect of the concentration of NaHCO <sub>3</sub> in irrigation water on root growth of <i>Hibiscus rosa-sinensis</i> L. 'Bimini Breeze' (left column) and 'Carolina Breeze' (right column).....	65
4.5. SPAD index at final harvest of <i>Hibiscus rosa-sinensis</i> L. 'Bimini Breeze' and 'Carolina Breeze' plants irrigated with increasing concentrations of NaHCO <sub>3</sub> . Bars represent the standard error for the mean. LSD <sub>0.05</sub> is the minimum significant difference for hibiscus 'Bimini Breeze' (BB) and Carolina Breeze' (CB) respectively, at $P \leq 0.05$ .....	68

FIGURE	Page
4.6. Effect of the concentration of NaHCO <sub>3</sub> in nutrient solution on shoot and root growth of 3-week old plants of <i>Hibiscus rosa-sinensis</i> L. 'Bimini Breeze' (left) and 'Carolina Breeze' (right) grown in hydroponics.....	71
4.7. Solution pH of <i>Hibiscus rosa-sinensis</i> L. 'Bimini Breeze' (A) and 'Carolina Breeze' (B) plants grown in hydroponics with increasing concentrations of NaHCO <sub>3</sub> (mM). .....	75
4.8. Iron-reductase activity ( $\mu\text{M Fe}\cdot\text{gr}^{-1}$ root dry mass $\cdot\text{hr}^{-1}$ ) of <i>Hibiscus rosa-sinensis</i> L. 'Bimini Breeze' and 'Carolina Breeze' grown in hydroponics with increasing concentrations of NaHCO <sub>3</sub> . Bars represent the standard error for the mean. LSD <sub>0.05</sub> is the minimum significant difference for hibiscus 'Bimini Breeze' (BB) and Carolina Breeze' (CB) respectively.....	77
4.9. SPAD index at final harvest of <i>Hibiscus rosa-sinensis</i> L. 'Bimini Breeze' and 'Carolina Breeze' grown in hydroponics with increasing concentrations of NaHCO <sub>3</sub> (mM). Bars represent the standard error of the mean (n=5). LSD <sub>0.05</sub> is the minimum significant difference for hibiscus 'Bimini Breeze' (BB) and Carolina Breeze' (CB) respectively. ....	78
5.1. Solution pH of <i>Helianthus annuus</i> 'Big Smile' plants grown in hydroponics with 0 and 5 mM of NaHCO <sub>3</sub> and varying NO <sub>3</sub> <sup>-</sup> : NH <sub>4</sub> <sup>+</sup> ratios: 1:0 (A), 0.75:0.25 (B), 0.5:0.5 (C), 0.25:0.75 (D), and 0:1 (E). Bars represent standard error of the mean. Arrows show beginning of NaHCO <sub>3</sub> treatments.	87
5.2. Solution pH at day 30 of <i>Helianthus annuus</i> 'Big Smile' plants grown in hydroponics with 0 mM (open bars) and 5 mM (solid bars) of NaHCO <sub>3</sub> and varying NO <sub>3</sub> <sup>-</sup> : NH <sub>4</sub> <sup>+</sup> ratios.....	89
5.3. Effect of the concentration of NaHCO <sub>3</sub> and varying NO <sub>3</sub> <sup>-</sup> :NH <sub>4</sub> <sup>+</sup> ratios on the growth and general appearance of shoots of <i>Helianthus annuus</i> 'Big Smile' plants at harvest time.....	90
5.4. Shoot height (cm) of <i>Helianthus annuus</i> 'Big Smile' plants grown in hydroponics with 0 and 5 mM of NaHCO <sub>3</sub> and varying NO <sub>3</sub> <sup>-</sup> : NH <sub>4</sub> <sup>+</sup> ratios: 1:0 (A), 0.75:0.25 (B), 0.5:0.5 (C), 0.25:0.75 (D), and 0:1 (E). Bars represent standard error for the mean (n=5). ....	91
5.5. Number of leaves per plant of <i>Helianthus annuus</i> 'Big Smile' plants grown in hydroponics with 0 and 5 mM of NaHCO <sub>3</sub> and varying NO <sub>3</sub> <sup>-</sup> : NH <sub>4</sub> <sup>+</sup> ratios: 1:0 (A), 0.75:0.25 (B), 0.5:0.5 (C), 0.25:0.75 (D), and 0:1 (E). Bars represent standard error for the mean (n=5). ....	92

FIGURE	Page
5.6. Total dry mass (g), root dry mass (g), and shoot:root ratio ( $\text{g}\cdot\text{g}^{-1}$ ) at final harvest of <i>Helianthus annuus</i> 'Big Smile' plants grown in hydroponics with 0 and 5 mM of $\text{NaHCO}_3$ and varying $\text{NO}_3^-:\text{NH}_4^+$ ratios. Bars represent standard error of the mean (n=5). *, NS, significant at $P\leq 0.05$ and non significant, respectively.....	94
6.1 Simplex centroid mixture design augmented with three interior points. Dotted lines are the coordinates for the components $V_1$ , $V_2$ , and $V_3$ .....	102
6.2. Example of a mixture experiment with the proportions of a hypothetical experiment with X, Y, and Z components.....	103
6.3. Simplex centroid mixture design augmented with three interior points. Dotted lines represent the coordinates for $\text{NH}_4^+$ , $\text{K}^+$ , and $\text{Na}^+$ .....	106
6.4. Mixture-amount experiment design consisting of two concentrations of $\text{HCO}_3^-$ , each was a simplex centroid mixture design augmented with three interior points. Dotted lines represent the $\text{Cs}^+$ , $\text{K}^+$ , and $\text{Na}^+$ coordinates.....	107
6.5. Two-component mixture-amount designs at three total mixtures.....	114
6.6. Effect of mixtures of varying proportions of $\text{NH}_4^+$ , $\text{K}^+$ , and $\text{Na}^+$ as counter-cations of $\text{HCO}_3^-$ on shoot and root dry mass of bean, <i>Phaseolus vulgaris</i> L. 'Poncho', grown in hydroponics with 5 mM total concentration. Top figures are 3-dimensional response surface and lower figures are counter plots.....	120
6.7 Effect of mixtures of varying proportions of $\text{NH}_4^+$ , $\text{K}^+$ , and $\text{Na}^+$ as counter-cations of $\text{HCO}_3^-$ on leaf area, leaf dry mass and total chlorophyll content of bean, <i>Phaseolus vulgaris</i> L. 'Poncho', grown in hydroponics with 5 mM total concentration. Top figures are 3-dimensional response surface and lower figures are counter plots.....	126
6.8. Effect of mixtures of varying proportions of $\text{Rb}^+$ , $\text{K}^+$ , and $\text{Na}^+$ as counter-cations of $\text{HCO}_3^-$ on shoot dry mass of bean, <i>Phaseolus vulgaris</i> L. 'Poncho', grown in hydroponics with 7.5 mM total concentration and two levels of $\text{HCO}_3^-$ .....	135



FIGURE	Page
6.9. Effect of mixtures of varying proportions of Rb <sup>+</sup> , K <sup>+</sup> , and Na <sup>+</sup> as counter-cations of HCO <sub>3</sub> <sup>-</sup> on root dry mass of bean, <i>Phaseolus vulgaris</i> L. ‘Poncho’, grown in hydroponics with 7.5 mM total concentration and two levels of HCO <sub>3</sub> <sup>-</sup> .....	136
6.10. Effect of mixtures of varying proportions of Rb <sup>+</sup> , K <sup>+</sup> , and Na <sup>+</sup> as counter-cations of HCO <sub>3</sub> <sup>-</sup> on leaf dry mass of bean, <i>Phaseolus vulgaris</i> L. ‘Poncho’, grown in hydroponics with 7.5 mM total concentration and two levels of HCO <sub>3</sub> <sup>-</sup> .....	143
6.11. Effect of mixtures of varying proportions of Rb <sup>+</sup> , K <sup>+</sup> , and Na <sup>+</sup> as counter-cations of HCO <sub>3</sub> <sup>-</sup> on leaf area of bean, <i>Phaseolus vulgaris</i> L. ‘Poncho’, grown in hydroponics with 7.5 mM total concentration and two levels of HCO <sub>3</sub> <sup>-</sup> .....	144
6.12. Effect of mixtures of varying proportions of Rb <sup>+</sup> , K <sup>+</sup> , and Na <sup>+</sup> as counter-cations of HCO <sub>3</sub> <sup>-</sup> on total chlorophyll concentration of bean, <i>Phaseolus vulgaris</i> L. ‘Poncho’, grown in hydroponics with 7.5 mM total concentration and two levels of HCO <sub>3</sub> <sup>-</sup> .....	146
6.13. Effect of mixtures of varying proportions of Rb <sup>+</sup> , K <sup>+</sup> , and Na <sup>+</sup> as counter-cations of HCO <sub>3</sub> <sup>-</sup> on water consumption of bean, <i>Phaseolus vulgaris</i> L. ‘Poncho’, grown in hydroponics with 7.5 mM total concentration and two levels of HCO <sub>3</sub> <sup>-</sup> .....	148
6.14. Effect of mixtures of varying proportions of Rb <sup>+</sup> , K <sup>+</sup> , and Na <sup>+</sup> as counter-cations of HCO <sub>3</sub> <sup>-</sup> on K <sup>+</sup> concentration of leaf, stem, and root tissue of bean, <i>Phaseolus vulgaris</i> L. ‘Poncho’, grown in hydroponics with 7.5 mM total concentration and two levels of HCO <sub>3</sub> <sup>-</sup> .....	149
6.15. Separation of the Na <sup>+</sup> toxicity/K <sup>+</sup> deficiency effect from the HCO <sub>3</sub> <sup>-</sup> toxicity effect on shoot growth of bean, <i>Phaseolus vulgaris</i> L. ‘Poncho’, grown in hydroponics with 7.5 mM total concentration and two levels of HCO <sub>3</sub> <sup>-</sup> , 0 mM (top response surface) and 7.5 mM (bottom response surface).....	154
6.16. Separation of the Rb <sup>+</sup> toxicity/K <sup>+</sup> deficiency effect from the HCO <sub>3</sub> <sup>-</sup> toxicity effect on shoot growth of bean, <i>Phaseolus vulgaris</i> L. ‘Poncho’, grown in hydroponics with 7.5 mM total concentration and two levels of HCO <sub>3</sub> <sup>-</sup> , 0 mM (top response surface) and 7.5 mM (bottom response surface).....	155

FIGURE	Page
6.17. Separation of the $\text{Rb}^+ + \text{Na}^+$ toxicity effect from the $\text{HCO}_3^-$ toxicity effect on shoot growth of bean, <i>Phaseolus vulgaris</i> L. 'Poncho', grown in hydroponics with 7.5 mM total concentration and two levels of $\text{HCO}_3^-$ , 0 mM (top response surface) and 7.5 mM (bottom response surface).....	156
6.18. Effect of mixtures of varying proportions of $\text{Rb}^+$ , $\text{K}^+$ , and $\text{Na}^+$ as counter-cations of $\text{HCO}_3^-$ on shoot dry mass of bean, <i>Phaseolus vulgaris</i> L. 'Poncho', grown in hydroponics with 7.5 mM total concentration and two levels of $\text{HCO}_3^-$ .....	160
6.19. Effect of mixtures of varying proportions of $\text{Rb}^+$ , $\text{K}^+$ , and $\text{Na}^+$ as counter-cations of $\text{HCO}_3^-$ on root dry mass of bean, <i>Phaseolus vulgaris</i> L. 'Poncho', grown in hydroponics with 7.5 mM total concentration and two levels of $\text{HCO}_3^-$ .....	161
6.20. Effect of mixtures of varying proportions of $\text{Rb}^+$ , $\text{K}^+$ , and $\text{Na}^+$ as counter-cations of $\text{HCO}_3^-$ on leaf area of bean, <i>Phaseolus vulgaris</i> L. 'Poncho', grown in hydroponics with 7.5 mM total concentration and two levels of $\text{HCO}_3^-$ .....	167
6.21. Effect of mixtures of varying proportions of $\text{Rb}^+$ , $\text{K}^+$ , and $\text{Na}^+$ as counter-cations of $\text{HCO}_3^-$ on leaf dry mass of bean, <i>Phaseolus vulgaris</i> L. 'Poncho', grown in hydroponics with 7.5 mM total concentration and two levels of $\text{HCO}_3^-$ .....	168
6.22. Effect of mixtures of varying proportions of $\text{Rb}^+$ , $\text{K}^+$ , and $\text{Na}^+$ as counter-cations of $\text{HCO}_3^-$ on total chlorophyll concentration of bean, <i>Phaseolus vulgaris</i> L. 'Poncho', grown in hydroponics with 7.5 mM total concentration and two levels of $\text{HCO}_3^-$ .....	171
6.23. Shoot and root dry mass at final harvest of bean, <i>Phaseolus vulgaris</i> L. 'Poncho', plants grown in hydroponics with increasing concentrations of $\text{NaHCO}_3$ and $\text{KHCO}_3$ . Bars represent standard error for the mean (n=5).....	175
6.24. Effect of 2.5, 5, and 7.5 mM total mixtures of varying $\text{K}^+$ and $\text{Na}^+$ proportions at two levels of $\text{HCO}_3^-$ on shoot dry mass of bean, <i>Phaseolus vulgaris</i> L. 'Poncho', plants. Open symbols=0 mM $\text{HCO}_3^-$ . Closed symbols=2.5, 5, or 7.5 mM $\text{HCO}_3^-$ . Dashed portion indicates a region of a probable $\text{K}^+$ deficiency effect. ....	182

FIGURE	Page
6.25. Effect of 2.5, 5, and 7.5 mM total mixtures of varying $K^+$ and $Na^+$ proportions at two levels of $HCO_3^-$ on root dry mass in bean, <i>Phaseolus vulgaris</i> L. 'Poncho', plants. Open symbols=0 mM $HCO_3^-$ . Closed symbols=2.5, 5, or 7.5 mM $HCO_3^-$ . Dashed portion indicates a region of a probable $K^+$ deficiency effect. ....	195
6.26. Effect of 2.5, 5, and 7.5 mM total mixtures of varying $K^+$ and $Na^+$ proportions at two levels of $HCO_3^-$ on leaf dry mass of bean, <i>Phaseolus vulgaris</i> L. 'Poncho', plants. Open symbols=0 mM $HCO_3^-$ . Closed symbols=2.5, 5, or 7.5 mM $HCO_3^-$ . Dashed portion indicates a region of a probable $K^+$ deficiency effect.....	200
6.27. Effect of 2.5, 5, and 7.5 mM total mixtures of varying $K^+$ and $Na^+$ proportions at two levels of $HCO_3^-$ on total chlorophyll concentration of bean, <i>Phaseolus vulgaris</i> L. 'Poncho', plants. Open symbols=0 mM $HCO_3^-$ . Closed symbols=2.5, 5, or 7.5 mM $HCO_3^-$ . Dashed portion indicates a region of a probable $K^+$ deficiency effect. ....	208
6.28. Effect of 2.5, 5, and 7.5 mM total mixtures of varying $K^+$ and $Na^+$ proportions at two levels of $HCO_3^-$ on water consumption of bean, <i>Phaseolus vulgaris</i> L. 'Poncho', plants. Open symbols=0 mM $HCO_3^-$ . Closed symbols=2.5, 5, or 7.5 mM $HCO_3^-$ . Dashed portion indicates a region of a probable $K^+$ deficiency effect. ....	213
6.29. Effect of mixtures of a 7.5 mM mixture of varying proportions of $K^+$ and $Na^+$ at two levels of $HCO_3^-$ , on $K^+$ (A) and $Na^+$ (B) net uptake of bean, <i>Phaseolus vulgaris</i> L. 'Poncho', plants. Bars represent the standard error for the mean (n=4).....	214
6.30. Separation of the $Na^+$ toxicity/ $K^+$ deficiency effect from the $HCO_3^-$ toxicity effect on shoot growth of bean, <i>Phaseolus vulgaris</i> L. 'Poncho', grown in hydroponics with a 2.5, 5, and 7.5 mM $K^+$ and $Na^+$ total concentration.....	216
6.31. Separation of the $Na^+$ toxicity effect from the $HCO_3^-$ toxicity effect on shoot growth of bean, <i>Phaseolus vulgaris</i> L. 'Poncho', grown in hydroponics with a 2.5, 5, and 7.5 mM $K^+$ and $Na^+$ total concentration.....	217

## CHAPTER I

### INTRODUCTION

Water quantity and quality are important factors to determine water availability and suitability for irrigation, but water quality is often neglected (Ayers and Westcot, 1976). Water quality can determine the crops that can or cannot be grown, the methods for irrigation, and the requirement of water treatments. Among the most important quality parameters, alkalinity of water is considered critical due to its impact on soil or growing medium solution pH (Petersen, 1996).

Alkalinity is defined as the concentration of soluble alkalis with the capacity to neutralize acids (Bailey, 1996). The major contributors to alkalinity are bicarbonate ( $\text{HCO}_3^-$ ) and carbonate ( $\text{CO}_3^{2-}$ ), while hydroxide, borate, ammonia, organic bases, phosphates, and silicates are considered minor contributors (Petersen, 1996).

Sometimes alkalinity is confused with alkaline pH. High or alkaline pH is caused by a high proportion of hydroxide ions in regard to the proportion of hydrogen ions (Handreck and Black, 2002). The hydroxide anion is a contributor to alkalinity, but it is a major contributor only when pH is higher than 11.0. At normal water pH,  $\text{HCO}_3^-$  and  $\text{CO}_3^{2-}$  are usually the alkalinity causing factors, and together, along with carbonic acid ( $\text{H}_2\text{CO}_3$ ) and  $\text{CO}_2$ , are known as the carbonate species or the carbonate system (Lindsay, 1979). Thus, water can have a high pH due to the hydroxide ions, but it may not have a high alkalinity since soluble alkalis are not present. Accordingly, water can have an acid pH but it may contain alkalinity if alkalis are present.

The carbonate system is a buffer since it can donate and accept  $\text{H}^+$ , imparting the ability to resist sudden changes in pH; thus, alkalinity makes water resistant to rapid changes in pH. Due to their predominance,  $\text{HCO}_3^-$  and  $\text{CO}_3^{2-}$  are the main buffering system that controls irrigation water and growing medium solution pH (Lindsay, 1979).

---

This dissertation follows the style of the Journal of the American Society for Horticultural Science.

## **ALKALINITY LEVELS IN TEXAS WATER**

Water reservoirs in Texas are classified as West, Central, and East reservoirs (Fig. 1)(Ground and Groeger, 1994). Alkalinity varies between 2 to 4 meq·L<sup>-1</sup> across the western and central regions, with much lower values in the east (Ground and Groeger, 1994). Alkalinity increases from east to central Texas from around 0.3 to 2.0 meq·L<sup>-1</sup>, and remains relatively constant at a longitude above 96<sup>0</sup> (Ground and Groeger, 1994). Alkalinity in west and central Texas is controlled by saturation and precipitation of Ca(HCO<sub>3</sub>)<sub>2</sub> (Ground and Groeger, 1994).

Associated to alkalinity, there is an increase in water pH in reservoirs located in west Texas; it goes from 6.6 to around 8.0 at longitude 96<sup>0</sup> and remains between 8.0 and 8.5 at higher longitudes (Ground and Groeger, 1994).

Reservoirs in west Texas are dominated by evaporation and chemical precipitation processes, while in central Texas, they are more affected by chemical weathering of the rich limestone deposits that characterize the geology of that area, along with a higher rainfall (Ground and Groeger, 1994). Reservoirs in east Texas are more diluted and the major mechanism affecting water chemistry is atmospheric precipitation and dilution of eastward flowing rivers (Ground and Groeger, 1994).

The most important anions are Cl<sup>-</sup> in west Texas, HCO<sub>3</sub><sup>-</sup> and CO<sub>3</sub><sup>2-</sup> in central Texas, and HCO<sub>3</sub><sup>-</sup> in east Texas (Ground and Groeger, 1994). In the Edwards plateau, the ionic composition of surface water is dominated by Ca<sup>2+</sup> and alkalinity, caused mostly by HCO<sub>3</sub><sup>-</sup>, which is acquired through weathering of limestone (Groeger and Gustafson, 1994).

## **CHEMISTRY OF THE CARBONATES**

Soil is an open system in regard to carbonate species because the CO<sub>2</sub> produced by root and microbial respiration escapes to the atmosphere and may return to precipitate carbonate minerals (Lindsay, 1979). Carbon dioxide and the carbonates cause changes in soil pH, acidifying and alkalinizing respectively, which in turn modifies the solubility of nutrients (Lindsay, 1979).

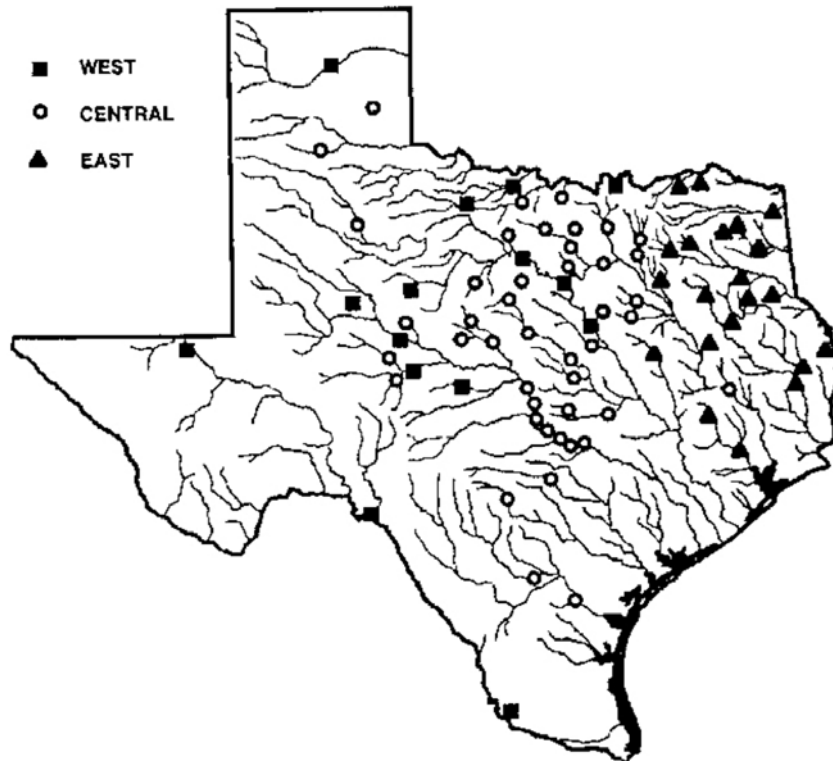
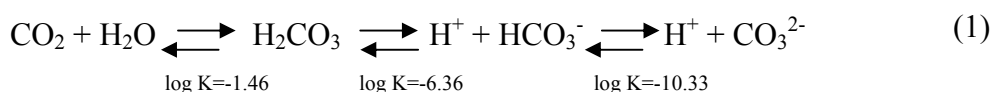

Fig. 1.1 Distribution of three classes of water reservoirs in Texas according to Ground and Groeger (1994).

The predominant form of carbonates is determined by pH (Whipker et al., 1996), which gives rise to four carbonate species:  $\text{CO}_2$ ,  $\text{H}_2\text{CO}_3$ ,  $\text{HCO}_3^-$  and  $\text{CO}_3^{2-}$ . Carbon dioxide dissolves in  $\text{H}_2\text{O}$  to render  $\text{CO}_2$  (dissolved gas) and  $\text{H}_2\text{CO}_3$  (not dissociated) in a ratio 3.86:1 (Lindsay, 1979). The non-dissociated  $\text{H}_2\text{CO}_3$  has a very important impact on soil and water pH. The dissociation constant for this reaction is:  $\log K = -1.46$  (Lindsay, 1979).

Carbonic acid dissociates to produce  $\text{H}^+$  and  $\text{HCO}_3^-$  ( $\log K = -6.36$ ), and  $\text{HCO}_3^-$  dissociates to  $\text{H}^+$  and  $\text{CO}_3^{2-}$  ( $\log K = -10.33$ ). Summarizing, the dissociation of the carbonate species is:

#### Dissolution of $\text{CO}_2$



In order to keep the same units, all carbonate species must be transformed to a logarithmic scale, and the  $\log K$  is now expressed as  $K$ . Hence, to determine the concentration of  $\text{H}_2\text{CO}_3$ , one should use the equation:  $\log \text{H}_2\text{CO}_3 = -1.46 + \log \text{CO}_2$ . To determine the concentration of  $\text{HCO}_3^-$ , one should use:  $\log \text{HCO}_3^- = -7.82 + \log \text{H}^+ + \log \text{CO}_2$ . To determine the concentration of  $\text{CO}_3^{2-}$ , the equation is:  $\log \text{CO}_3^{2-} = -18.15 + 2(\log \text{H}^+) + \log \text{CO}_2$ .

To determine the fraction of each species, the equations are:

$$\text{Mole Fraction of } \text{HCO}_3^- = \frac{\text{Mole of } \text{HCO}_3^-}{\text{Mole of } \text{H}_2\text{CO}_3 + \text{Mole of } \text{HCO}_3^- + \text{Mole of } \text{CO}_3^{2-}}$$

Substituting for each species:

$$\text{Mole Fraction of } \text{HCO}_3^- = \frac{(10^{-7.82} * \text{CO}_2/\text{H}^+)}{(10^{-1.46} / \text{CO}_2) + (10^{-7.82} * \text{CO}_2/\text{H}^+) + (10^{-18.15} * \text{CO}_2/(\text{H}^+)^2)}$$

Since the concentration of  $\text{H}^+$  can be expressed as pH, and for a given concentration of  $\text{CO}_2$ , which may vary,  $\text{CO}_2$  becomes a constant susceptible of elimination. Thus the final equation would take the following form:

$$\text{Mole Fraction of HCO}_3^- = \frac{(10^{-7.82} / 10^{-\text{pH}})}{(10^{-1.46}) + (10^{-7.82} / 10^{-\text{pH}}) + (10^{-18.15} / 10^{-\text{pH}(2)})}$$

Similarly:

$$\text{Mole Fraction of H}_2\text{CO}_3 = \frac{(10^{-1.46})}{(10^{-1.46}) + (10^{-7.82} / 10^{-\text{pH}}) + (10^{-18.15} / 2 * 10^{-\text{pH}(2)})}$$

$$\text{Mole Fraction of CO}_3^{2-} = \frac{(10^{-18.15} / 2 * 10^{-\text{pH}})}{(10^{-1.46}) + (10^{-7.82} / 10^{-\text{pH}}) + (10^{-18.15} / 2 * 10^{-\text{pH}(2)})}$$

Since  $\text{CO}_2$  is canceled out, these equations are independent of the concentration and tell nothing about the actual carbonate species concentration, however they are useful for showing the pH effect on the distribution of carbonate species (Fig. 1.2)(Lindsay, 1979).

The carbonate form predominating in soils is determined by soil pH (Whipker, 1996). As observed in Fig. 1.2, the proportion of  $\text{H}_2\text{CO}_3$  and  $\text{HCO}_3^-$  is in equilibrium when solution pH is equal to 6.36, but as pH increases, the proportion of  $\text{HCO}_3^-$  increases, while the proportion of  $\text{H}_2\text{CO}_3$  starts to decrease.

The carbonate system consists of only  $\text{HCO}_3^-$  when the pH is around 8.34. The proportion of  $\text{HCO}_3^-$  declines in solutions with a pH higher than 8.34, but the proportion of  $\text{CO}_3^{2-}$  increases. In terms of actual concentration, or activity, it is necessary to allow for the  $\text{CO}_2$  concentration in the system; therefore, it is necessary to calculate the speciation of the carbonates for each concentration of  $\text{CO}_2$ . In Fig. 1.3, the lines represent the activity in a logarithmic scale for the carbonate species at  $\text{CO}_2 = 0.0003$  atm. If the concentration of  $\text{CO}_2$  increases from 0.0003 to 0.100 atm, the lines must be shifted upward in 2.52 units ( $\log(0.100 \text{ atm}/0.0003 \text{ atm})$ ), thus at pH 8,  $\text{HCO}_3^-$  is shifted from  $10^{-3.34} \text{ M}$  to  $10^{-0.82} \text{ M}$  ( $10^{-3.34+2.52} \text{ M} = 10^{-0.82} \text{ M}$ ) (Lindsay, 1979).



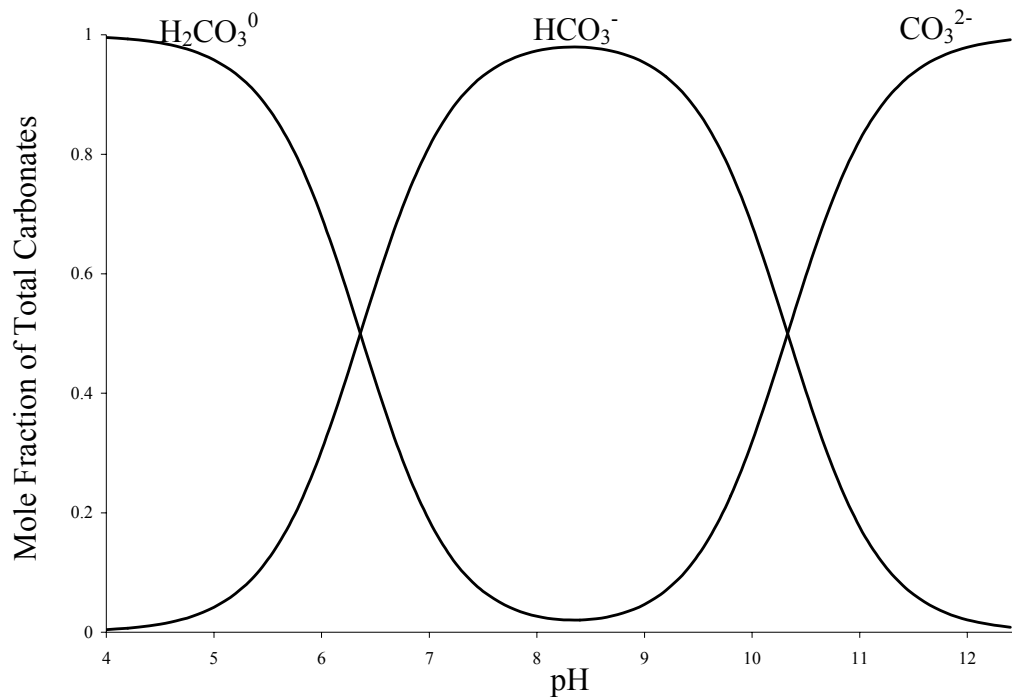

Fig. 1.2. Effect of the solution pH on the proportion of the carbonate species. Adapted from Lindsay (1979)

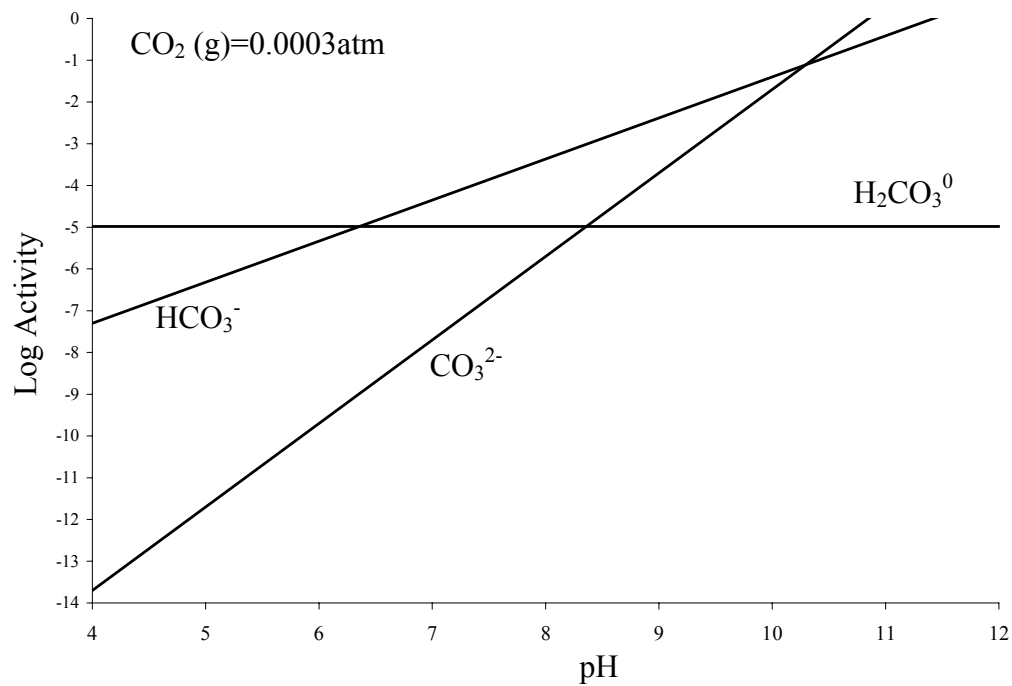

Fig. 1.3. Effect of solution pH on the activity of carbonate species in equilibrium with 0.0003 atm of  $\text{CO}_2$ . Adapted from Lindsay (1979).

## RELATIONSHIP BETWEEN ALKALINITY, $\text{HCO}_3^-$ , AND pH

Alkalinity describes the concentration of soluble alkalis (salts that can neutralize acids) (Bailey, 1996), and measures the water buffering capacity caused by the removal of  $\text{H}^+$  from solution (Kuehny and Morales, 1998). The removal of  $\text{H}^+$  causes the pH increase associated with high alkalinity.

Bicarbonate is a buffer since it can donate and accept  $\text{H}^+$ , imparting the capacity to resist sudden changes in pH. Under normal growing medium pH,  $\text{HCO}_3^-$  reacts with  $\text{H}^+$  in the growing medium solution (see reaction (1)), which might raise pH up to undesirable levels (Bierbaum, 1994).

Bicarbonate can also be produced by dissolution of  $\text{CO}_2$  in water (see reaction (1)) or by dissolving calcite or other carbonates, as demonstrated in reaction (2):

### Dissolution of Calcite



Calcite acts as a weak base coupled with  $\text{HCO}_3^-$ , which in turn acts as an acid (Lucena, 2000):

The double behavior of  $\text{HCO}_3^-$ , as an acid and a base, provides a system able to buffer pH changes at a wide range (Lucena, 2000). The kinetics of both processes is very important. The dissolution of  $\text{CO}_2$  is very slow because it is not catalyzed by any enzyme, but the system is oversaturated because the concentration of  $\text{H}_2\text{CO}_3$  is much larger than expected from the concentration of  $\text{CO}_2$  in the environment (Lucena, 2000). Dissolution of calcite is also a slow process and it is normally unsaturated, thus the  $\text{HCO}_3^-$  produced diffuses easily and the equilibrium concentration is achieved rapidly (Lucena, 2000).

## OTHER FACTORS THAT INCREASE ALKALINITY

There are other factors that contribute to increased alkalinity in soils. In soils with organic matter at high content and a fast decay rate,  $\text{CO}_2$  partial pressure is above the concentration of  $\text{CO}_2$  in the atmosphere, up to 0.5% to 1.5% by volume (Larcher, 1975), or 10 times higher than the atmospheric concentration. Compacted soils (Bloom and Inskeep, 1986) or soils with little porosity, have a slow diffusion of  $\text{CO}_2$ , which

increases its concentration (Bloom and Inskeep, 1986; Vapaavuory and Pelkonen, 1985). A high moisture content or waterlogging also reduces CO<sub>2</sub> diffusion (Vapaavuory and Pelkonen, 1985), so CO<sub>2</sub> stays in the soil reacting with water to produce H<sub>2</sub>CO<sub>3</sub>, which dissociates to HCO<sub>3</sub><sup>-</sup> and CO<sub>3</sub><sup>2-</sup> (Vapaavuory and Pelkonen, 1985). The slow diffusion of CO<sub>2</sub> can raise alkalinity up to 1 to 4 mM (Takkar et al., 1987) or up to 10 mM if soil is calcareous and rich in organic matter (McCray and Matocha, 1992). Some authors have suggested that such a high concentration of HCO<sub>3</sub><sup>-</sup> is unlikely to reach such high levels in nature (Vapaavuory and Pelkonen, 1985).

### **DIRECT AND INDIRECT EFFECTS OF ALKALINITY ON PLANTS**

Some authors suggest that alkalinity affects plant growth via a decrease in the solubility of nutrients. The decrease in solubility is caused by the increase of pH associated with increasing concentrations of carbonates (Lindsay and Thorpe, 1954; Lunt et al., 1956). For example, the concentration of soluble Fe in soil decreases 1000 fold per unit increase in pH (Fig. 1.4). Zinc, Cu, and Mn are also less soluble at alkalinity-induced high pH (Barber et al., 1995).

Other authors indicate that the high pH caused by alkalinity may directly inhibit growth of sensitive plants, as demonstrated in *Lupinus* species (Bertoni et al., 1992; Tang and Robson, 1993). However, in most instances it is not the pH, but the high concentration of HCO<sub>3</sub><sup>-</sup> that is the major factor for plant growth inhibition (Lee and Woolhouse, 1969) due to its toxic effects (Matkin and Petersen, 1971; Wadleigh and Brown, 1952). This was demonstrated by maintaining maize plants growing in solution at pH 8.0 with the buffer HEPES, without HCO<sub>3</sub><sup>-</sup>. The high pH without high HCO<sub>3</sub><sup>-</sup> did not cause any negative effect on root and shoot elongation (Lee and Woolhouse, 1969). In Douglas fir, an inhibition in root respiration is caused by a high concentration of HCO<sub>3</sub><sup>-</sup> (Qi et al., 1994), which normally occurs at high rate in the apical zones of growing roots (Bingham and Stevenson, 1993). Thus, a rapid decline in root growth induced by HCO<sub>3</sub><sup>-</sup> might be, at least in part, the result of inhibited respiration (Alhendawi et al., 1997). Burley tobacco seedlings roots developed a brown burned

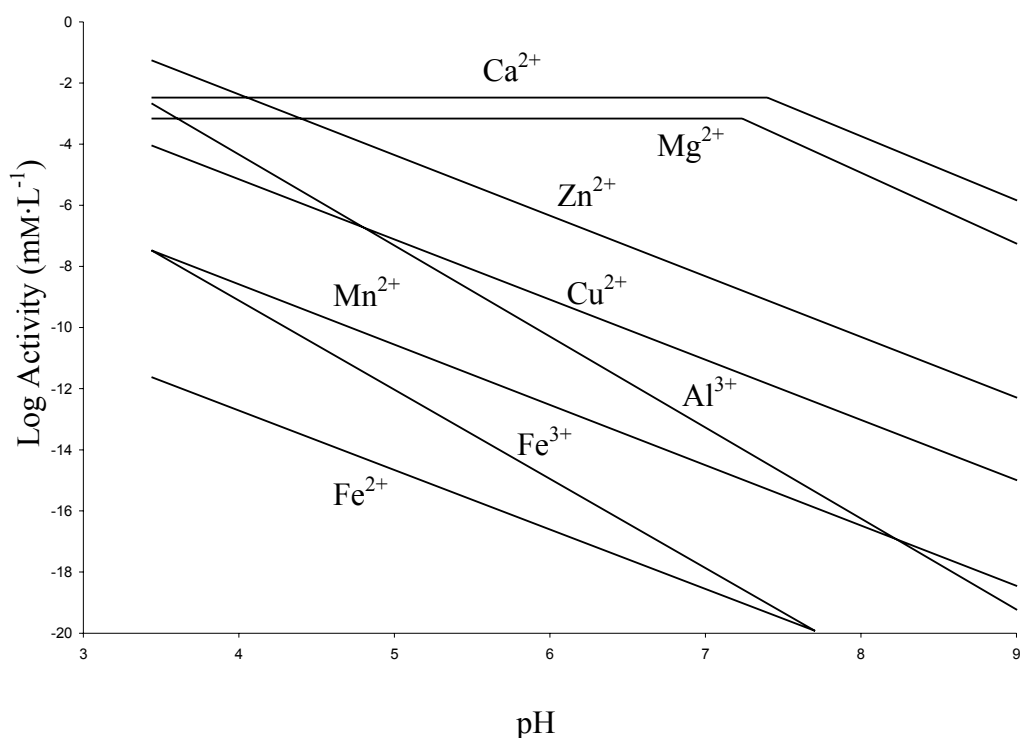

Fig 1.4. Effect of pH on the activity of Fe forms and other nutrients. Adapted from Barber, 1995.

appearance when they were in contact with  $\text{HCO}_3^-$  or  $\text{Na}^+$  in nutrient solution at 8 mM (Pearce et al., 1999b), sustaining that alkalinity also induces direct effects.

Hepes and Tris, as  $\text{HCO}_3^-$ , are buffers with similar effect on pH. They can be used to study the  $\text{HCO}_3^-$ -independent-of-pH action by preparing solutions with identical pH (Romera et al., 1992). Iron reducing capacity in sunflower and cucumber was affected in the order: Tris >  $\text{HCO}_3^-$  > Hepes, indicating that  $\text{HCO}_3^-$  has an independent-of-pH effect on plants (Romera et al., 1992).

### LEAF CHLOROSIS AND ALKALINITY

The most conspicuous symptom of excessive alkalinity is the induction of an interveinal chlorosis in the youngest leaves of plants and stunted growth (Pearce et al., 1999a and b). Leaf chlorosis is correlated to a decrease in chlorophyll content in the upper leaves, as it has been reported for sensitive sunflower cultivars (Alcántara et al.,

1988), soybean (McCallister et al., 1989), grapevine (Nikolic and Kastori, 2000), sugar beet (Campbell and Nishio, 2000), peach (Alcántara et al., 2000), and other plants. Leaf chlorosis has been attributed to a high pH-induced Fe deficiency due to a decrease in Fe uptake (Bertoni et al., 1992).

Iron is required for the synthesis of the heme structure, which is an essential part of the structure of chlorophyll (Nikolic and Kastori, 2000; Terry and Abadià, 1986). If Fe availability is inadequate, the synthesis of chlorophyll is impaired (De la Guardia and Alcántara, 2002; Terry and Abadià, 1986).

Chlorosis symptoms begin by 12 h after the application  $\text{HCO}_3^-$  in sunflower plants. Visible chlorotic areas appeared at the base of the youngest leaves and proceeded to the tip until the whole leaf became chlorotic (Kosegarten et al., 2001). Older leaves may show small chlorotic areas at the leaf base (Kosegarten et al., 2001).

If leaf chlorosis is associated with calcareous soils, it is known as "lime-induced chlorosis" (McCallister et al., 1989; Romera et al., 1997), although  $\text{HCO}_3^-$  is more detrimental than lime (Romera et al., 1997) since  $\text{CaCO}_3$  reacts with  $\text{H}_2\text{O}$  and  $\text{CO}_2$  rendering  $\text{Ca}^{2+}$  and  $\text{HCO}_3^-$  (Havlin et al., 1999). Other factors causing leaf chlorosis are poor aeration due to soil compaction and water saturation (Römheld, 2000), which may inhibit Fe uptake.

Sometimes leaf chlorosis is not due to a decrease in Fe uptake, as reported for soybean (McCallister et al., 1989). Rather it may be due to tissue Fe not being available or active (Marschner, 1995). The concept "chlorosis paradox" defines cases in which chlorosis seems related to Fe deficiency despite an acceptable concentration of Fe is present in plant tissues (Römheld, 2000). In hydroponics,  $\text{HCO}_3^-$  has also been demonstrated to inhibit Fe utilization, inducing chlorosis (Fleming et al., 1984).

Leaf chlorosis might be a consequence of a limitation on other root-derived factors required for leaf expansion (Alhendawi et al., 1997), which explains the frequent shoot and root growth inhibition occurring prior the occurrence of chlorosis manifestation (Alhendawi et al., 1997).

## **ALKALINITY AND IRRIGATION WATER IN GREENHOUSE CROPS**

From a sample of 289 analysis performed in water used for irrigation of greenhouse or nursery facilities, it has been estimated that the average alkalinity in Texas is  $200 \text{ mg}\cdot\text{L}^{-1}$  (as  $\text{CaCO}_3$ ), which is above the suggested concentrations (Argo et al., 1997). Seventy one percent of these samples were above the recommended level, and Texas turned out to be the state with the second highest percentage of samples above limits, surpassed only by Michigan (Argo et al., 1997).

Greenhouse growers usually are aware of the influence that pH has on plant nutrition, but in many cases they are not familiar with how alkalinity affects irrigation water and growing medium solution pH (Ludwig, 1985). Alkalinity in irrigation water prevents the acidification of growing medium solution by consuming  $\text{H}^+$  resulting in a higher pH, and through continuous irrigation, growing medium pH could reach dangerous levels because of the accumulation of  $\text{HCO}_3^-$ , and  $\text{CO}_3^{2-}$ . Growing medium solution pH controls the solubility of nutrients and under high pH, a deficiency of many micronutrients, mainly Fe, is frequently reported.

High alkalinity in water may be harmful but water with zero alkalinity is not necessarily recommended. The buffer capacity of alkalinity helps prevent sudden pH changes in the growing medium solution, which may cause unbalances in nutrient availability. Therefore, a low level of alkalinity in water is desirable.

Most of the information about the effect of alkalinity in plants has been obtained with field crops, and there is little research concerning acceptable or threshold levels in ornamental greenhouse plants. The general objective of this research was to provide information about the limits of tolerance to alkalinity in ornamental plants, to study the interaction of ions such as ammonium ( $\text{NH}_4^+$ ) and nitrate ( $\text{NO}_3^-$ ) on the response of plants to alkalinity, as well as the effect of the counter-ions potassium ( $\text{K}^+$ ), sodium ( $\text{Na}^+$ ), cesium ( $\text{Cs}^+$ ), ammonium ( $\text{NH}_4^+$ ), and rubidium ( $\text{Rb}^+$ ) on the response to alkalinity.

## CHAPTER II

### LITERATURE REVIEW

#### EFFECT OF $\text{HCO}_3^-$ ON PLANT GROWTH

Plants respond to elevated  $\text{HCO}_3^-$  concentrations with decreased shoot growth. Shoot growth inhibition is associated with a decrease in number of leaves, fresh and dry mass, and shoot elongation. Sunflower (Alcántara et al., 1988), white lupinus (Bertoni et al., 1992), tomato, petunia (Bailey and Hammer, 1986), celery (Mason et al., 1989), chrysanthemum (Kramer and Peterson, 1990), apple (Zhou et al., 1984), tobacco transplants (Rideout et al., 1995), rice (Yang et al., 1994), sorghum, maize, barley (Alhendawi et al., 1997), grapevine (Römheld, 2000), olive, peach (De la Guardia and Alcántara, 2002), pea (Zribi and Gharsalli, 2002), and roses (Fernandez-Falcón et al., 1986), exhibited stunted growth when growing in either soil or nutrient solution containing a high concentration of  $\text{HCO}_3^-$ . The detrimental concentration for  $\text{HCO}_3^-$  reported varies between 4 to 20 mM.

Tolerance to  $\text{HCO}_3^-$  has been reported for some cultivars in crops such as sunflower (Alcántara et al., 1988), pea (Zribi and Gharsalli, 2002) and rice (Yang et al., 1994).

Decreased shoot growth is attributed to a low photosynthetic rate occurring in the  $\text{HCO}_3^-$ -induced chlorotic leaves. A lower photosynthetic rate results from impaired chlorophyll synthesis due to low translocation of Fe (Bavaresco et al., 1999) or to lower solubility of Fe in soil or growing medium solution.

Root growth inhibition is one of the earliest visually detected effects of  $\text{HCO}_3^-$ , as observed in sugar beet (Campbell and Nishio, 2000). Grapevine plants treated with a solution with pH 8.5 and 10 mM  $\text{HCO}_3^-$  exhibited a 16% decrease in root mass (Römheld, 2000). Zinc-inefficient rice cultivars showed a severe impairment of root dry mass and length and number of roots, after two days of growing in soil with 5.0 mM  $\text{HCO}_3^-$  (Yang et al., 1994). In contrast, Zn-efficient rice cultivars showed a slight

increase in root growth parameters with a concentration between 5 to 10 mM (Yang et al., 1994).

Increasing concentration of  $\text{HCO}_3^-$  in nutrient solutions depressed root length in maize, sorghum, and barley; but root diameter increased in response to elevated concentrations of  $\text{HCO}_3^-$  (Alhendawi et al., 1997). Sugar beet plants also increased root thickness, and a higher production of lateral roots was observed three days after Fe deficiency and  $\text{HCO}_3^-$  treatments started (Campbell and Nishio, 2000). Root thickness also was observed in Fe-efficient cultivars but at a lesser extent (Campbell and Nishio, 2000).

Tobacco seedlings treated with  $\text{NaHCO}_3$  developed a brown, burned appearance in the roots (Pearce et al., 1999b). This might be due to either  $\text{HCO}_3^-$  or  $\text{Na}^+$  (Pearce et al., 1999b). According to the authors, the effect was probably due to  $\text{HCO}_3^-$  rather than  $\text{Na}^+$  since acidified solutions prepared with  $\text{NaHCO}_3$  had no negative effect on roots (Rideout et al., 1995).

Elevated  $\text{HCO}_3^-$  concentrations have been shown to inhibit root respiration (Qi et al., 1994). Since root respiration rate is very high in the apical zone (Bingham and Stevenson, 1993), root meristem, and therefore root growth, is affected (Alhendawi et al., 1997).

An increase, or no negative effect, in root dry mass has also been reported. Peach rootstocks and olive plants maintained or increased root weight when treated with either 10 mM  $\text{HCO}_3^-$  or Fe stress (De la Guardia and Alcántara, 2002). Both sensitive and tolerant pea cultivars also increased root mass when treated with solutions containing  $\text{HCO}_3^-$  (Zribi and Gharsalli, 2002).

Cluster roots, also called proteoid roots, are formed in some plants, such as *Casuarina glauca*, when exposed to P and/or Fe deficiency (Zaïd et al., 2003). In white lupinus the number of cluster roots is six times greater in P-deprived compared to Fe-deprived plants (Hagström et al., 2001). When incubating roots of *C. glauca* in chrome-azurool S-agar on blue plates, the root system exhibited orange halos around the cluster roots, indicating the production of a ferric chelating agent due to Fe removal from the



dye (Zaid et al., 2003). In *Ficus benjamina*, an increase in cluster root formation was reported when plants were grown in Fe-deficient conditions (Rosenfield et al., 1991). The cluster roots also possessed the highest Fe-reduction capacity compared to the reduction capacity of lateral and primary roots.

### **IS THERE A SIGNAL TO DETECT HCO<sub>3</sub><sup>-</sup> STRESS?**

It has been suggested that the rapid decline in shoot growth observed even at low concentrations of HCO<sub>3</sub><sup>-</sup> is related to a root-derived signal, like a hormone (Alhendawi et al., 1997). A mechanism like this has been reported for other stress factors in the root environment such as root growth restriction (Ternes et al., 1994), water logging, and drought stress (Tardieu et al., 1992).

Other authors report evidence suggesting that the effect of HCO<sub>3</sub><sup>-</sup> is not due to an inhibitory factor translocable from the roots. This was proven by using a split-root system. In cucumber, the principal root was cut to increase growth of laterals and then laterals were separated into two sections. One section was treated with HCO<sub>3</sub><sup>-</sup> while the other was kept as control (Romera et al., 1992). The section of roots maintained in solutions with no HCO<sub>3</sub><sup>-</sup> showed a high Fe<sup>2+</sup> reducing capacity despite the other section was maintained in solutions with 10 mM NaHCO<sub>3</sub>. The Fe<sup>2+</sup> reducing capacity was diminished in the roots maintained with 10 mM NaHCO<sub>3</sub> (Romera et al., 1992). Results obtained in grafted sunflower seedlings also support the lack of a translocable factor in response to HCO<sub>3</sub><sup>-</sup>. The approach-grafted seedlings, with just one shoot left, showed normal acidification and reducing capacity in the root section with no HCO<sub>3</sub><sup>-</sup>, whether or not the other section was treated (Romera et al., 1992).

### **IRON UPTAKE AND ACCUMULATION**

#### **Effect of HCO<sub>3</sub><sup>-</sup> on Tissue Concentration of Fe**

There is evidence indicating that HCO<sub>3</sub><sup>-</sup> causes a decrease in Fe uptake (Alhendawi et al., 1997; Bertoni et al., 1992), Fe accumulation (Bertoni et al., 1992), or an increase in internal precipitation of Fe (Fernández-Falcón et al., 1986). There are two hypotheses attempting to explain HCO<sub>3</sub><sup>-</sup>-induced Fe chlorosis. One of these hypotheses suggests that HCO<sub>3</sub><sup>-</sup> in the rhizosphere inhibits Fe acquisition (Fernández Falcón et al.,

1986; Römheld, 2000), while the other states that Fe is absorbed but it is inactivated by the alkalization of root tissues caused by  $\text{HCO}_3^-$  (Bertoni et al., 1992; Römheld, 2000). The main objection for the latter is that in some plants there is not a significant increase in xylem sap pH or apoplastic leaf fluids (Römheld, 2000).

In Fe-inefficient sunflower plants and white lupine, Fe uptake decreased 14% and 38%, respectively (Alcántara et al., 1988; Bertoni et al., 1992). Apple seedlings in solution culture containing 1 mM  $\text{HCO}_3^-$  exhibited decreased Fe concentration, from 130 to 20  $\mu\text{g}\cdot\text{g}^{-1}$  (Zhou et al., 1984). Similar results were reported for maize, sorghum, and barley grown in solutions containing 5 to 20 mM  $\text{HCO}_3^-$  (Alhendawi et al., 1997). Even 5 mM  $\text{HCO}_3^-$  significantly decreased the concentration of Fe in shoot and root tissues in terms of both concentration ( $\text{mg Fe}\cdot\text{kg}^{-1}$  dry weight) and total content ( $\text{mg Fe}\cdot\text{plant}^{-1}$ ) (Alhendawi et al., 1997). Greenhouse roses treated for seven months with 6.82 to 9.56 mM  $\text{HCO}_3^-$  showed a 20 to 30% decrease in leaf Fe concentration (Fernández-Falcón et al., 1986). In 4-week long experiments, shoots of grapevine accumulated 50% less Fe when grown in nutrient solution containing 10 mM  $\text{HCO}_3^-$  ( $610 \text{ mg}\cdot\text{L}^{-1}$ ) (Römheld, 2000). Leaves and roots of peach rootstocks had a significant decrease in Fe concentration when treated with 5 to 10 mM  $\text{HCO}_3^-$  (De la Guardia and Alcántara, 2002).

### **Bicarbonate and Fe Chlorosis: the Chlorosis Paradox**

In some cases,  $\text{HCO}_3^-$  or lime-induced chlorosis is not associated with a decrease in Fe uptake since Fe has been found in plant tissues at more than adequate concentration for normal growth (Mengel and Geurtzen, 1986). The term ‘chlorosis paradox’ is used to describe the induction of leaf chlorosis despite leaves containing a concentration of Fe higher than that in green leaves (Mengel, 1994; Römheld, 1997; Römheld, 2000). The chlorosis paradox is observed only when shoot growth is severely impaired and the calculation of Fe is made on a dry mass basis, implying that the higher concentration of Fe in chlorotic leaves is a secondary event of Fe deficiency (Nikolic and Römheld, 2002).

Some experiments report a higher concentration of Fe due to the use of Fe-chelates, such as Fe-EDTA (Alhendawi et al., 1997), as reported with tobacco seedlings growing in solution culture with high levels of  $\text{HCO}_3^-$  (Pearce et al., 1999b). In contrast, the concentration of total Fe decreased by 14% in white lupine, despite the presence of Fe-chelates, while  $\text{Fe}^{2+}$  concentration decreased by 38% (Bertoni et al., 1992).

The increase in Fe concentration may be due to decrease in plant growth and to the dry matter dilution effect (Pearce et al., 1999b), also called 'negative' dilution effect (Römheld, 2000), when the concentration of Fe declines during leaf expansion (Römheld, 2000; Venkat Raju and Marschner, 1981) or shoot growth (Bavaresco et al., 1999). The increase in Fe concentration may also explain the poor correlation between chlorosis and the frequently reported high Fe concentration (Bavaresco et al., 1999; Römheld, 2000).

Another argument supporting the fact that the chlorosis paradox depends more on a negative dilution is the higher concentration of all the macro and micronutrients, except for Ca, Mg and B, in kiwifruit chlorotic leaves (Tagliavini et al., 2000).

### **Bicarbonate and Root and Leaf Apoplastic pH**

Leaf apoplast pH is very important in controlling the availability of nutrients such as Fe, Cu, Mn, and Zn in leaves (Yu et al., 2000). Bicarbonate may play a role in apoplastic pH changes as demonstrated in sunflower plants treated with 10 mM  $\text{HCO}_3^-$ . Treated plants exhibited an increase of 0.8 units in leaf apoplastic pH (Mengel et al., 1994). An increase of 0.5 units in xylem sap-internal pH has been reported for maize and sorghum grown in the presence of 20 mM  $\text{HCO}_3^-$  (Alhendawi et al., 1997). In contrast, other reports indicate that there is not a significant increase of leaf apoplastic pH in sunflower (Kosegarten et al., 2001; Nikolic and Römheld, 2002).

Fluorescence-boronic acid is a dye that binds covalently to  $\text{OH}^-$  groups in the cell wall, which allows the determination of apoplastic pH (Kosegarten et al., 1999). In maize plants grown for 12 hours at pH 5, root apoplastic pH was 4.95. When external solution pH was increased to 8.6 with 10 mM  $\text{KHCO}_3$ , root apoplastic pH was 5.2. Increased pH to 8.6 with  $\text{KNO}_3$ , caused the apoplast to have a pH 5.4 (Kosegarten et al.,

1999). Increasing the pH to 8.6 with both  $\text{KNO}_3$  and  $\text{KHCO}_3$ , caused an increase in root apoplastic pH to 5.7 (Kosegarten et al., 1999), indicating that  $\text{HCO}_3^-$  in presence of  $\text{NO}_3^-$  caused alkalization of the apoplast in all root zones. The  $\text{H}^+$  pumped out of the cytosol was neutralized by the  $\text{HCO}_3^-$ , what could explain the increase in pH (Kosegarten et al., 1999).

Iron trapped in leaf apoplast due to alkaline pH should be mobilized if the pH of apoplast is decreased by increasing  $\text{Fe}^{3+}$  reduction, and thus uptake of  $\text{Fe}^{2+}$  into the symplast is increased. This reduction of  $\text{Fe}^{3+}$  to  $\text{Fe}^{2+}$  would have a re-greening effect on chlorotic leaves, as confirmed in sunflower leaves sprayed with the equivalent of 93 mM  $\text{H}^+$  from citric acid (Kosegarten et al., 2001) and in kiwifruit (Tagliavini et al., 2000). The re-greening was due to the remobilization of Fe in the apoplast (Kosegarten et al., 2001). Sprays of sulphuric acid were not effective at a concentration equivalent to 4.6 mM  $\text{H}^+$  in sunflower (Kosegarten et al., 2001), but it was effective in kiwifruit (Tagliavini et al., 2000). Sprays of ascorbic acid and indole acetic acid have also been reported to increase the synthesis of chlorophyll in Fe-deficient plants (Tagliavini et al., 2000).

The acid growth theory (Rayle and Cleland, 1992) indicates that acidity in the apoplast activates the cell wall-loosening processes, stimulating cell wall extension. Ammonium ion can promote a faster root growth compared to  $\text{NO}_3^-$  via a low apoplastic pH in the transition to the elongation zone (Bloom et al., 1993; Kosegarten et al., 1999). In contrast, under  $\text{NO}_3^-/\text{HCO}_3^-$  treatment, the alkalization of the apoplast may inhibit root growth due to the neutralization of the acidity required for the induction of cell wall extension (Kosegarten et al., 1999).

### **Bicarbonate and Fe-Reduction Capacity**

Bicarbonate has a detrimental effect on Fe-reduction capacity. Bicarbonate in the root apoplast might inhibit the reduction of Fe by affecting Fe-reductase activity (Kosegarten et al., 2001; Nikolic and Römheld, 2000; Zribi and Gharsally, 2002). The decrease in the Fe-reductase activity by  $\text{HCO}_3^-$  is due to its buffer capacity (Romera et al., 1997). Due to the strong buffer capacity of  $\text{HCO}_3^-$ , the  $\text{H}^+$  released by the proton

pumps are neutralized, resulting in high pH of the root apoplast and inhibition of the plasma membrane-bound Fe-reductase (Romera et al., 1992). In this way,  $\text{HCO}_3^-$  can maintain solution pH around 7.5 to 8.0, impairing the Fe-reductase activity since its optimal pH is 6.5 to 7.5 (Eckhardt and Buckhout, 2000).

Bicarbonate depresses Fe-reductase activity, but addition of Fe to solutions may activate the enzymatic function. In Fe-starved sunflower and cucumber plants, Fe-reduction capacity was decreased similarly in both plant species, but in plants supplied with a low concentration of Fe, the inhibitory effect of  $\text{HCO}_3^-$  was smaller (Romera et al., 1992). Bicarbonate also affected the reductase activity in peach 'Nemaguard', but it recovered after transferring the plants from a solution containing 2.5  $\mu\text{M}$  Fe and 10 mM  $\text{NaHCO}_3$  to 100  $\mu\text{M}$  and 10 mM, respectively, which caused re-greening in plants (Alcántara et al., 2000). Sunflower plants growing with 10 mM  $\text{HCO}_3^-$  and without Fe showed a severe decrease in Fe reductase activity, but when Fe was added to the solution containing the same  $\text{HCO}_3^-$  concentration, the activity was enhanced (Romera et al., 1997)

Soybean plants treated with  $\text{HCO}_3^-$  showed a severe decrease in Fe-reduction capacity (0.009  $\mu\text{mol}$  of  $\text{Fe}^{3+}$ ) compared to  $\text{HCO}_3^-$  free plants (0.205  $\mu\text{mol}$  of  $\text{Fe}^{3+}$ ) (Dofing et al., 1989). Apparently,  $\text{HCO}_3^-$  resulted in the suppression or inactivation of the mechanism by which roots release reductants (Dofing et al., 1989). Similar responses to  $\text{HCO}_3^-$  have been demonstrated with other buffers, such as HEPES, Tris and KOH (Romera et al., 1992; Römheld et al., 1982).

Iron deficient bean plants stopped  $\text{H}^+$  extrusion when  $\text{Zn}^{2+}$  and  $\text{Mn}^{2+}$  were removed from the nutrient solution, but after re-supplying  $\text{Zn}^{2+}$ ,  $\text{Cu}^{2+}$ ,  $\text{Mn}^{2+}$ , and even  $\text{Fe}^{2+}$ , plants resumed  $\text{H}^+$  extrusion and  $\text{Fe}^{3+}$  reduction capacity (Sijmons and Bienfait, 1986). For this reason, it has been suggested that  $\text{Zn}^{2+}$ ,  $\text{Cu}^{2+}$ , and  $\text{Mn}^{2+}$  are either a constituent or a cofactor of a compound that plays a role in both acidification and  $\text{Fe}^{3+}$ -reduction capacity (Romera et al., 1997).

## PLANT RESPONSES TO Fe DEFICIENCY

Iron can be absorbed by plants as  $\text{Fe}^{3+}$  or  $\text{Fe}^{2+}$  (Havlin et al., 1999), ferric and ferrous Fe, respectively, although  $\text{Fe}^{2+}$  is preferred (Marschner, 1995). Ferrous iron has been called “active iron”; it is the best indicator of the Fe nutritional status of leaves (Nikolic and Kastori, 2000).

Plants have developed mechanisms to overcome Fe deficiency, including: a) increased Fe-reductase capacity, b) net extrusion of  $\text{H}^+$ , c) release of phenolic compounds, such as caffeic acid in dicots and non-graminaceous monocots, d) release of phytosiderophores to act as  $\text{Fe}^{3+}$  chelators in graminaceous plants, and e) formation of proteoid roots with a high reductase activity and high capacity to release  $\text{H}^+$  in perennial and annual dicots (Marschner, 1995). The mechanism including increased reduction and extrusion of  $\text{H}^+$  is known as strategy I; the release of phytosiderophores is strategy II (Marschner, 1995).

### Strategy I

This mechanism is present in all dicot plants and non-graminaceous monocots. Iron uptake rate in strategy I plants increased 4 to 10 times, after re-supplying of Fe, in Fe-deficient tomato and cucumber plants, respectively, compared to Fe-supplemented plants (Zaharieva and Römheld, 2000).

Releasing  $\text{H}^+$  gives rise to the acidification of the rhizosphere (Wei et al., 1998). Iron efficient sugar beet cultivars acidify the nutrient solution in response to Fe deficiency from 6.0 to 3.5 when no  $\text{HCO}_3^-$  was added, but with 2.5 mM  $\text{HCO}_3^-$ , the acidification went from 7.5 to 6.5. Thus,  $\text{HCO}_3^-$  was buffering the pH change due to neutralization of  $\text{H}^+$ . Iron inefficient sugar beet cultivars acidified the solution from 6.0 to 4.6 (Campbell and Nishio, 2000). Iron inefficient cultivars slightly increased solution pH compared to Fe-efficient cultivars when Fe was added to the solution along with 2.5 mM  $\text{NaHCO}_3$ . This has been attributed to an anionic exchange of  $\text{HCO}_3^-$  and  $\text{OH}^-$  for the  $\text{NO}_3^-$  taken up (Campbell and Nishio, 2000).

## Strategy II

In graminaceous plants, Fe deficiency causes increased release of phytosiderophores (PS)(Marschner et al., 1986; Mori, 1999) which act as high affinity chelates (Zaharieva and Römheld, 2000). Phytosiderophores are non-proteinogenic aminoacids that form a PS-Fe<sup>3+</sup> complex in order to make Fe<sup>3+</sup> more mobile, facilitating its uptake (Marschner et al., 1986). Rice and oat plants release PS, such as avenic and mugenic acid, following a diurnal pattern, with the maximum release a few hours after the onset of the light period (Marschner et al., 1986). Barley, a calcicole plant, has a higher production of PS, enabling this plant to grow at elevated HCO<sub>3</sub><sup>-</sup> concentrations (Lee and Woolhouse, 1969).

Alkaline pH, such as that caused by HCO<sub>3</sub><sup>-</sup> and CO<sub>3</sub><sup>2-</sup>, can depress the release of PS, although it is only slightly affected when pH is between 5 to 8 (Marschner et al., 1986). Since a very high pH and HCO<sub>3</sub><sup>-</sup> and CO<sub>3</sub><sup>2-</sup> concentrations are required to inhibit the PS release, it has been stated that graminaceous plants are less susceptible to alkalinity than dicots and non-graminaceous plants (Alhendawi et al., 1997).

## EFFECT OF HCO<sub>3</sub><sup>-</sup> ON PLANT NUTRITION

Contradictory information in regard to the effect of HCO<sub>3</sub><sup>-</sup> on plant nutrition has been reported. A decrease in nutrient concentration can be caused by a) the inhibitory effect of HCO<sub>3</sub><sup>-</sup> on metabolic processes (Bialczyk and Lechowsky, 1992; Bialczyk et al., 1994; Vapaavuori and Pelkonen, 1985), b) an impairment on root activity (Yang et al., 1993), c) a decrease in nutrient availability in soils with a high pH (Alcántara et al., 1988), and d) an increase in net efflux of nutrients (Alhendawi et al., 1997).

In contrast, an increase in nutrient concentration may be associated with a higher concentration of organic compounds triggered by HCO<sub>3</sub><sup>-</sup>, and the necessity of maintaining electrochemical balance of the solution (Bialczyk and Lechowski, 1995). A decrease in plant growth is also another possibility, since there is a dilution factor by less dry matter accumulation (Pearce et al., 1999b).

## **Nitrogen**

Total N concentration in  $\text{HCO}_3^-$ -treated plants was decreased in white lupinus (Bertoni et al., 1992), tobacco (Pearce et al., 1999b), celery (Tremblay et al., 1989), maize, sorghum and soybean (Alhendawi et al., 1997), but it was unaffected in mums (Kramer and Peterson, 1990). In contrast, N concentration increased slightly in tobacco plants treated with 8 mM  $\text{HCO}_3^-$  (Pearce et al., 1999a).

## **Potassium**

Potassium concentration in  $\text{HCO}_3^-$ -treated plants was increased in non-tolerant sunflower plants (Alcántara et al., 1988), white lupinus (Bertoni et al., 1992), celery (Tremblay et al., 1989), tobacco (Pearce et al., 1999b), peach (Alcántara et al., 2000) and tomato (Bialczyk et al., 1994). The concentration was decreased in tobacco (Pearce et al., 1999b), mums (Kramer and Peterson, 1990), maize, sorghum, and beans (Alhendawi et al., 1997), rice (Yang et al., 1993), and roses (Fernández-Falcón et al., 1986). Leaf  $\text{K}^+$  concentration was unaffected in olive and peach plants treated with  $\text{HCO}_3^-$ , but it decreased in the root (De la Guardia and Alcántara, 2002).

## **Phosphorus**

Phosphorus concentration was decreased in  $\text{HCO}_3^-$ -treated sunflower (Alcántara et al., 1988), tobacco (Pearce et al., 1999b) and chrysanthemum (Kramer and Peterson, 1990), but was unaffected in white lupinus (Bertoni et al., 1992), and increased in celery (Tremblay et al., 1989). The concentration of P remained unaffected in tomato seedlings (Bialczyk et al., 1994). Soybean grown in calcareous soils showed an elevated concentration of P associated with low Fe; this might be due to decreased Fe activity in the presence of P, leading to Fe inactivation inside the plant (McCallister et al., 1989). This can be corroborated by analyzing the phosphorus/iron ratio; plants exhibited chlorosis under high P/Fe ratio, but if the ratio is low, the plants resulted in less chlorosis (McCallister et al., 1989). The increase in P uptake may result from the higher  $\text{H}^+$  extrusion in roots in order to maintain the electrochemical neutrality caused by a higher cation-anion uptake (McCallister et al., 1989). In olive and peach rootstocks, the concentration of P decreased in plants treated with  $\text{HCO}_3^-$  but increased in roots by



300% to 500% (De la Guardia and Alcántara, 2002). The increase of P in roots might be due to its precipitation at the alkaline pH associated with the application of  $\text{HCO}_3^-$  (De la Guardia and Alcántara, 2002).

### **Calcium**

Calcium concentration increased in sunflower (Alcántara et al., 1988), white lupinus (Bertoni et al., 1992), tobacco seedlings (Pearce et al., 1999b), peach (De la Guardia and Alcántara, 2002), and tomato seedlings (Bialczyk et al., 1994) treated with a high concentration of  $\text{HCO}_3^-$ . In contrast, in olive (De la Guardia and Alcántara, 2002) and celery, the concentration of calcium in plant tissue decreased (De la Guardia and Alcántara, 2002; Tremblay et al., 1989). A high level of  $\text{HCO}_3^-$  had little effect on  $\text{Ca}^{2+}$  concentration in shoots of maize and sorghum, but it markedly increased  $\text{Ca}^{2+}$  concentration in roots (4 to 5 fold); about 25% of  $\text{Ca}^{2+}$  was accounted for as  $\text{CaCO}_3$  in both species (Alhendawi et al., 1997).

### **Magnesium**

Magnesium levels usually increase when  $\text{HCO}_3^-$  is high, as reported for white lupinus (Bertoni et al., 1992), sunflower (Alcántara et al., 1988), and peach rootstocks (De la Guardia and Alcántara, 2002). In tobacco, the concentration of  $\text{Mg}^{2+}$  remained unchanged (Pearce et al., 1999b) and in olive it decreased (De la Guardia and Alcántara, 2002) when the concentration of  $\text{HCO}_3^-$  was high.

### **Zinc**

Bicarbonate has also been regarded as the major Zn deficiency-causing factor (Yang et al., 1993), as observed in olive, peach rootstocks (De la Guardia and Alcántara, 2002) and white lupinus (Bertoni et al., 1992). The mechanisms by which  $\text{HCO}_3^-$  causes such deficiency are very similar to those for Fe. Bicarbonate inhibits the Zn absorption by roots (Dogar and Hai, 1980) and inhibits the translocation of Zn from roots to shoots (Forno et al., 1975). Root growth retardation is also one of the earliest events reported for Zn-inefficient rice cultivars exposed to solutions containing 5 to 50 mM  $\text{HCO}_3^-$  as  $\text{NaHCO}_3$  (Yang et al., 1994).

Similar to Fe, plants can accumulate more Zn even when growing in high  $\text{HCO}_3^-$ . Tobacco seedlings in solution culture accumulated more Zn in shoots with the highest  $\text{HCO}_3^-$  treatment, but this was attributed to a concentration effect as a result of a lower dry matter production (Pearce et al., 1999b)

### **Other Micronutrients**

A high concentration of  $\text{HCO}_3^-$  induced decrease in Cu concentration in white lupinus (Bertoni et al., 1992), in Mn in white lupinus (Bertoni et al., 1992), rice (Yang et al., 1993), and olive plants (De la Guardia and Alcántara, 2002), but increased in sunflower (Alcántara et al., 1988) and shoots of peach rootstock (De la Guardia and Alcántara, 2002).

### **INTERACTION BETWEEN SODIUM AND ALKALINE pH**

High salinity, caused by 60 mM NaCl, had a more detrimental effect on the total chlorophyll and dry mass of tomato, cucumber, pepper (Kaya et al., 2002b) and strawberry plants (Kaya et al., 2002b) compared to an alkaline pH of 8.5 (induced by using KOH); however, when both salinity and high pH were combined, the effect was much more negative (Kaya et al., 2002b). The addition of 3 mM  $\text{K}_2\text{SO}_4$  restored the loss of dry mass and total chlorophyll (Kaya et al., 2002a; Kaya et al., 2002b).

### **UPTAKE OF $\text{HCO}_3^-$ AND $\text{CO}_2$ BY ROOTS**

Potato (Arteca et al., 1980), willow cuttings (Vapaavuori and Pelkonen, 1985) and tomato (Bialczyk and Lechowski, 1992) have been shown to absorb inorganic carbon as  $\text{HCO}_3^-$  or dissolved  $\text{CO}_2$  from soil solution. Using labeled  $\text{HCO}_3^-$  ( $\text{H}^{14}\text{CO}_3^-$ ) in solution-cultured tomato, Bialczyk and Lechowski (1992) were able to recover 61% of the total radioactivity in the roots after 74 h, and 39% was recovered in shoots and leaves, indicating uptake of C. Similar results were reported in willow plants growing in  $\text{CO}_2$ -free solutions containing 0.015 or 1.473 mM  $\text{NaH}^{14}\text{CO}_3^-$  since plants showed accumulation of  $^{14}\text{C}$  in leaves and shoots after 6 h (Vapaavuori and Pelkonen, 1985). The carbon can be utilized in the synthesis of organic acids and other organic compounds that are then transported to the plant tops (Bialczyk and Lechowski, 1992; Lance and Rustin, 1984; Maxwell et al., 1984).

## CHAPTER III

### DETERMINATION OF TOLERANCE AND TOXICITY ALKALINITY LIMITS IN SELECTED GREENHOUSE ORNAMENTAL PLANTS

#### INTRODUCTION

Water quality is an important factor in the ornamental industry because it can determine the species that can be grown, methods of irrigation, and the necessity of water pretreatments. Among the most important quality parameters, alkalinity of water is considered critical due to its direct effect on growing medium solution pH and its direct and indirect effects on plant growth and quality. Alkalinity is a measure of the buffering capacity of water. High alkalinity removes  $H^+$  from the solution, which in turn raises the pH (Kuehny and Morales, 1998).

Greenhouse growers usually are aware of the influence of pH on plant nutrition, but in many cases they are not informed of the effect of alkalinity on irrigation water and growing medium solution pH (Ludwig, 1985). Through continuous irrigation with water of high alkalinity, growing medium pH could reach dangerous levels because of  $HCO_3^-$  and  $CO_3^{2-}$  accumulation, the main components of alkalinity (Whipker, 2001).

The most conspicuous symptom of excessive alkalinity is the induction of interveinal chlorosis in the youngest leaves and stunted growth (Pearce et al., 1999a; Pearce et al., 1999b; Lucena, 2000). Leaf chlorosis is correlated with a decrease in chlorophyll content in the upper leaves, as reported for sensitive sunflower cultivars (Alcántara et al., 1988; Nikolic and Römheld, 2002), soybeans (McCallister et al., 1989), grapevine (Bavbaresco et al, 1999; Nikolic and Kastori, 2000; Römheld, 2000) sugar beet (Campbell and Nishio, 2000), peach (Alcántara et al., 2000; De la Guardia and Alcántara, 2002; Tagliavini et al, 2000), casuarinas (Zaïd et al, 2003), olive (De la Guardia and Alcántara, 2002), pea (Zribi and Gharsalli, 2002), pear, and kiwifruit (Tagliavini et al., 2000).

Alkalinity-induced leaf chlorosis has been attributed to a Fe deficiency due to decreased Fe uptake (Bertoni et al., 1992) and/or Fe availability. Iron is required for the

synthesis of the heme structure, the essential part of chlorophyll (Terry and Abadià, 1986; Nikolic and Kastori, 2000). If Fe in plant tissue is not available or inadequate, the synthesis of chlorophyll is impaired (Terry and Abadià, 1986; De la Guardia and Alcántara, 2002). Alkalinity reduces the solubility of Fe due to the high pH associated with the consumption of  $H^+$  by  $HCO_3^-$ .

High alkalinity in water may be harmful, but water with zero alkalinity is not necessarily recommended. The buffer capacity of alkalinity prevents sudden pH changes in growing medium solution, which may cause unbalances in nutrient availability. Therefore, a low level of alkalinity in water is desirable (Bailey, 1996). In general, it is accepted that ideal alkalinity in irrigation water varies between 0 and 3.2 mM  $HCO_3^-$ . Some authors recommend the levels of alkalinity indicated in Table 3.1.

Table 3.1. Recommended concentrations of alkalinity, as  $HCO_3^-$ , for irrigation of ornamental plants.

Recommended Alkalinity <sup>z</sup>		
mM	mg·L <sup>-1</sup>	Reference
0 – 1.2	0 – 75	Nelson (1998)
0 – 1.6	0 – 100	Peterson and Kramer (1991)
0.7 – 2.6	40 – 160	Bierbaum (1994)
1 – 2	61 – 122	Dole (1994)

<sup>z</sup> as  $HCO_3^-$

The maximum alkalinity that a plant can tolerate depends on plant species, the age of the plant, size of the container, type of growing medium used (Whipker et al., 1996), length of the crop period, and growing medium volume and buffer capacity (Kessler, 1999).

Growing medium can accumulate more alkalinity-inducing salts in crops with longer schedules due to additional irrigations (Nelson, 1998). As for container size, the smaller the size the less the volume of growing medium, and the lower the buffering capacity of this growing medium (Bailey, 1996). Since in smaller containers the plants

are grown for a shorter time, these plants are more immature and more sensitive to alkalinity. In plug production, recommended alkalinity varies from 0.7 to 1.3 mM  $\text{HCO}_3^-$  (Bailey, 1996). For 4 to 5" potted plants, it varies from 0.7 to 2.1 mM  $\text{HCO}_3^-$ , and for 6" potted plants it is from 1.2 to 2.6 mM  $\text{HCO}_3^-$  (Bailey, 1996).

Most of the information about the effect of alkalinity in plants has been obtained in field crops, but there is little research concerning acceptable or threshold levels in ornamental greenhouse plants. A concentration between 8.2 and 16.4 mM  $\text{HCO}_3^-$  affected growth of chrysanthemum (Kramer and Peterson, 1990) and 10 meq·L<sup>-1</sup>  $\text{Ca}(\text{HCO}_3)_2$  (5 mM  $\text{Ca}(\text{HCO}_3)_2$ ) caused chlorosis in azalea (Rutland, 1971) and chrysanthemum (Rutland and Bukovac, 1971). Pansy plants showed a decrease in flower number and necrosis of leaf edges; and impatiens was chlorotic with a concentration higher than 3.3 mM  $\text{HCO}_3^-$  (200 mg·L<sup>-1</sup>) (Kuehny and Morales, 1998). Wallace and Wallace (1986) reported a list with more than 50 ornamental plants susceptible to Fe-chlorosis, which potentially makes them susceptible to alkalinity. Among the greenhouse crops reported were African daisy, osteospermum, vinca, azalea, hibiscus, hydrangea, rhododendron, rose, petunia, iris, gladiolus, geranium, verbena, and several genera of ferns.

The small amount of published reports in regard to the effect of  $\text{HCO}_3^-$  in ornamental greenhouse crops stresses the necessity of more research on these crops. For this reason, this study had the objective of determining the effect of alkalinity in irrigation water on plant growth of four selected greenhouse plant species and both the tolerance and toxic levels of  $\text{HCO}_3^-$ .

## **MATERIALS AND METHODS**

Four species were studied: chrysanthemum (*Chrysanthemum morifolium* Ramat) 'Miramar', rose (*Rosa* sp L.) 'Pink Cupido', vinca (*Catharanthus roseus* (L.) G. Don) 'Apricot Delight', and hibiscus (*Hibiscus rosa-sinensis*) 'Bimini Breeze' and 'Mango Breeze'. The experiments were conducted in a glass greenhouse. Average temperature, relative humidity and radiation were measured at noon by using a Hobo meter (Onset Co. Computer Corporation. Pocasset, MA). Temperature, relative humidity and

irradiation averaged 29.7<sup>0</sup>/17<sup>0</sup>C (daytime/nighttime), 58.9%, and 544.0  $\mu\text{mol}\cdot\text{m}^{-2}\cdot\text{s}^{-1}$ , respectively.

Plants were transplanted into 10.2 cm diameter standard pots containing Sunshine #2<sup>®</sup> (Sun Gro Horticulture, Bellevue, WA) sphagnum peat-perlite mix. Sunshine #2<sup>®</sup> is a commercial growing medium with lime added but no additional nutrients. The growing medium was pre-plant amended with 4.7  $\text{kg}\cdot\text{m}^{-3}$  of 14-14-14 Osmocote<sup>®</sup> (Scotts Sierra, Marysville, OH) and 1  $\text{kg}\cdot\text{m}^{-3}$  of Micromax<sup>®</sup> (Scotts Sierra, Marysville, OH) trace element mix.

Simulated alkalinity in irrigation water was prepared by using  $\text{NaHCO}_3$  at 0, 2.5, 5, 7.5, and 10 mM in reverse osmosis water (0, 153, 305, 458, and 610  $\text{mg}\cdot\text{L}^{-1}$  of  $\text{HCO}_3^-$ ). A 24.7 L-tank of each solution was prepared 24 h before use to allow pH stabilization. The resulting pH was 7.19 $\pm$ 0.09, 8.29 $\pm$ 0.06, 8.48 $\pm$  0.05, 8.61 $\pm$ 0.04 and 8.65 $\pm$ 0.04 (pH  $\pm$  standard error, n=5), respectively. Each plant was top watered by hand with the respective  $\text{NaHCO}_3$  solution as needed to achieve a leaching fraction between 0.2 and 0.3.

The experimental design was a completely randomized design with 5 replications; one pot with one plant was used per replication. Data were analyzed with ANOVA (SAS Institute, Inc. N.C.). For data that showed a significant F test, the LSD multiple range test was used as a best estimate of differences between means. Linear, quadratic and cubic effects were determined by using orthogonal contrasts.

Chrysanthemum cuttings (Yoder Brother Inc., Parrish, Fla.) were transplanted on 20 Mar. 2000 and kept under long-day condition from 24 Mar. to 9 Apr. 2000 using incandescent bulbs from 2200 HR to 0200 HR. Plants were pinched on 30 Mar. 2000 by removing the tip, leaving 10 leaves on each plant. Plant tops were harvested 20 June 2000. Rose rooted cuttings (Texas A&M University, Overton, TX.) were transplanted on 24 Mar. 2000, pinched on 10 Apr. 2000 and harvested on 29 June. Hibiscus liners (Yoder Brothers, Inc., Salinas Ca.) were transplanted on 26 Mar. 2000. A soft pinch to eliminate 0.5 to 1 cm of the top of each cutting was carried out two weeks after transplanting. Plants were harvested on 26 and 27 June 2000 for hibiscus 'Bimini

Breeze' and 'Mango Breeze', respectively. Vinca plugs (Color Spot, Huntsville, Texas) were transplanted on 27 Mar. and harvested on 28 June 2000.

The parameters measured were plant height on a weekly basis, SPAD index of the newly formed leaves, leaf number, shoot fresh and dry mass and growing medium pH at experiment termination. SPAD index was determined with a SPAD Meter<sup>®</sup> (Model 501, Minolta Camera Co., LTD, Japan). Fresh mass was determined by weighing after the plants were cut at the growing medium surface. The plants were placed in individual paper bags, dried in an oven at 75<sup>0</sup>C for 72 h, and then weighed for dry mass. The growing medium was separated into three horizontal sections: top, middle and bottom layer. Samples were collected, minus roots, to determine growing medium pH for each layer. The growing medium was thoroughly mixed with nanopure water in a 1:2 proportion (30 ml of growing medium: 60 ml of water), allowed to sit for 60 min and then filtered. The filtrate pH was determined with a TwinpH<sup>®</sup> meter (Spectrum Technologies, Inc., Plainfield, Ill.).

For rose, hibiscus, and vinca, the parameters measured included leaf fresh and dry mass. In rose the number of flowers was also measured, while in hibiscus and vinca leaf area was measured with a Portable Area Meter (Li-Cor LI-3000<sup>®</sup>, LI-COR Biosciences, Lincoln, Nebr.).

The concentration of NaHCO<sub>3</sub> at which maximum shoot dry mass and SPAD index occurred was estimated by using the model that best fit the results. The best model was determined by choosing the one with the highest  $R^2$ . For quadratic models,  $Y = \beta_0 + \beta_1 X + \beta_2 X^2$ , the highest SPAD reading and shoot mass were estimated with the formula  $Y = -\beta_1 / 2\beta_2$ , which is a modification of the formula to determine the point at which the tangent has a zero slope in quadratic functions. Once the highest SPAD and shoot mass were calculated, the concentration of NaHCO<sub>3</sub> at which these values are obtained were estimated by using the models. A 15% decrease from the maximum shoot dry mass and SPAD index was considered the threshold to declare the toxic concentration of NaHCO<sub>3</sub>. The 15% decrease was calculated based on the maximum shoot mass or SPAD index predicted by the models.

## RESULTS AND DISCUSSION

### Chrysanthemum

Overall growth was slightly affected by increasing concentration of NaHCO<sub>3</sub> in irrigation water (Fig. 3.1A). The plants were slightly less green with 2.5 and 5 mM NaHCO<sub>3</sub>, and a visible chlorosis appeared with 7.5 mM. Root formation was severely inhibited in plants irrigated with water containing 10 mM NaHCO<sub>3</sub>, compared to control plants (Fig. 3.2A).

Leaf number, shoot fresh and dry mass (Table 3.2), and plant height (Fig. 3.3) were not significantly affected by the concentration of NaHCO<sub>3</sub>. Similar results were reported in chrysanthemum by Peterson and Kramer (1991) since dry mass was unaffected significantly in plants irrigated with up to 8.2 mM HCO<sub>3</sub><sup>-</sup>. The authors reported that shoot dry mass was significantly decreased 42% with solutions containing 16.4 mM HCO<sub>3</sub><sup>-</sup>. The severe chlorosis induced by alkalinity made the plants not suitable for marketing (Figure 3.1A). Compared to the control, plants irrigated with 5 mM of NaHCO<sub>3</sub> showed a significant ( $P \leq 0.05$ ) 21% decrease in SPAD index, which decreased to around 72% with 10 mM (Table 3.2)(Fig. 3.4).

Since there was not a significant effect of the concentration of NaHCO<sub>3</sub> on shoot dry mass, the best parameter to determine the optimum and toxic limits was SPAD index. The concentration of NaHCO<sub>3</sub> at which the maximum SPAD index was obtained was calculated with the formula  $X = -\beta_1/2\beta_2$ . The coefficients were obtained from the quadratic model shown in Fig. 3.4 and Table 3.3. Accordingly, the maximum SPAD index in chrysanthemum occurred at -1.0 mM. Since -1 mM is outside of the domain of interest in the model, it is concluded that the optimum concentration for chrysanthemum was 0 mM NaHCO<sub>3</sub> (Table 3.3). The maximum predicted SPAD index at this treatment was 62.8. Subtracting the 15% decrease in SPAD index required to estimate the toxic limits, the minimum index tolerated was 53.4. This SPAD index was estimated to occur at 4.1 mM NaHCO<sub>3</sub>, which would be the toxic limit.



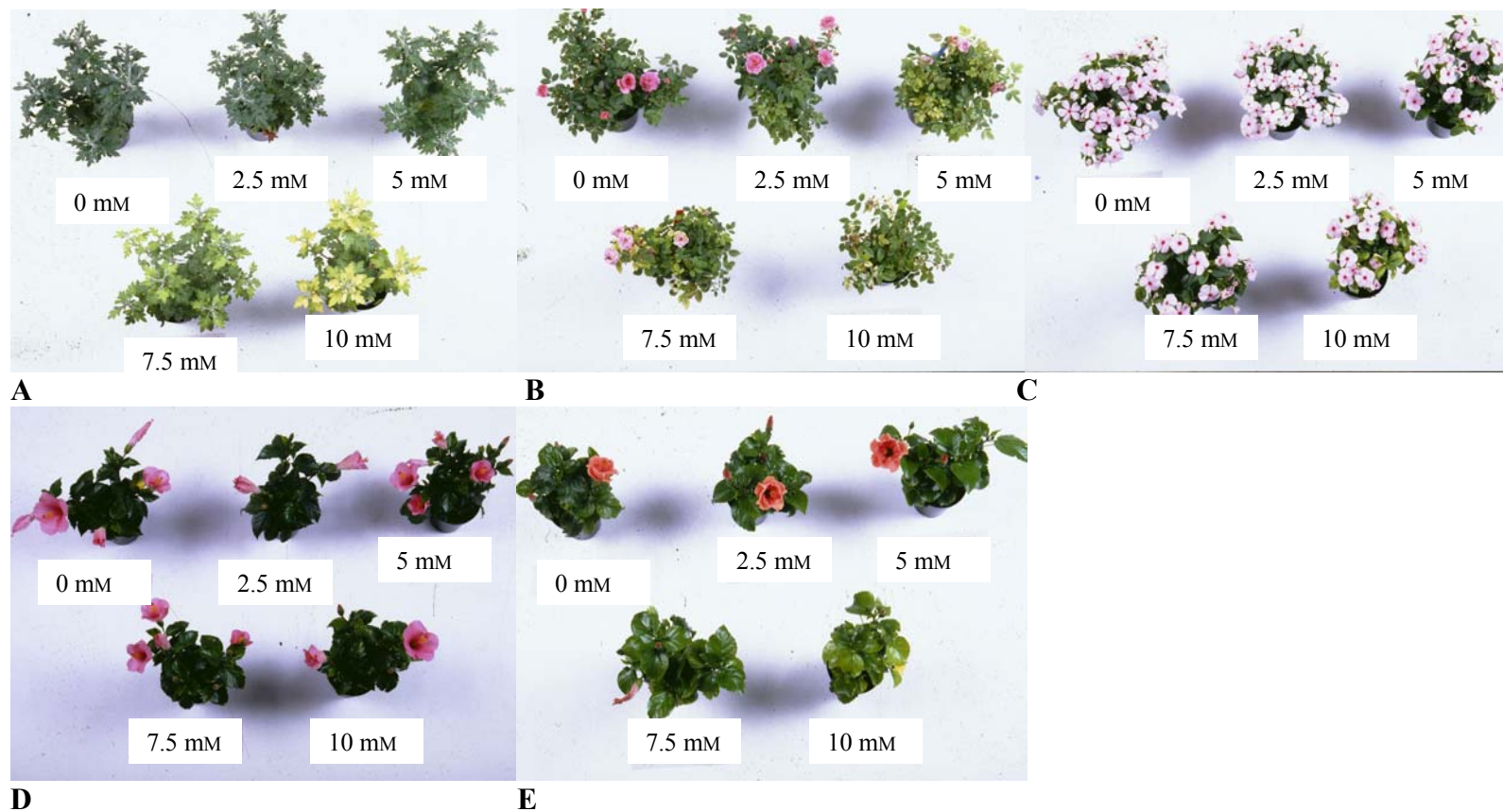

Fig. 3.1. Effect of the concentration of  $\text{NaHCO}_3$  in irrigation water on plant growth of (TOP) *Chrysanthemum morifolium* Ramat 'Miramar' (A), *Rosa* sp. L. 'Pink Cupido', *Catharanthus roseus* 'Apricot Delight' (B), and (BOTTOM) *Hibiscus rosa-sinensis* L. 'Mango Breeze' (D) and 'Bimini Breeze' (E).

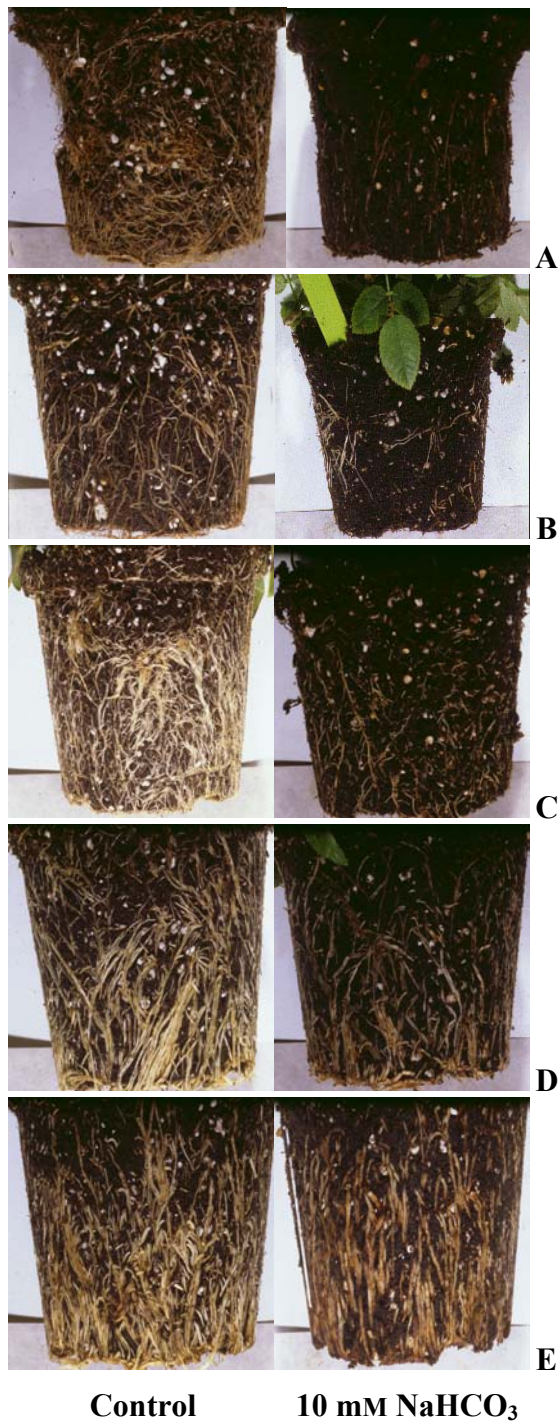

Fig. 3.2. Effect of the concentration of NaHCO<sub>3</sub> in irrigation water on root growth of *Chrysanthemum morifolium* Ramat 'Miramar' (A), *Rosa* sp L. 'Pink Cupido' (B), *Catharanthus roseus* 'Apricot Delight' (C), and *Hibiscus rosa-sinensis* L. 'Mango Breeze' (D) and 'Bimini Breeze' (E). Left column is for control plants, right column is for plants irrigated with 10 mM NaHCO<sub>3</sub>.

Table 3.2. Effect of the concentration of  $\text{NaHCO}_3$  in irrigation water on shoot growth parameters, SPAD index, and growing medium pH of *Chrysanthemum morifolium* Ramat 'Miramar'.

NaHCO <sub>3</sub> (mM)	Shoot Growth Parameters			SPAD index <sup>z</sup>	Growing Medium pH <sup>y</sup>		
	Leaf Number	Shoot Fresh Mass (g)	Shoot Dry Mass (g)		Top layer	Middle layer	Bottom layer
0	143	64.7	17.9	61.8a	5.14e	5.26e	5.25e
2.5	150	64.0	17.9	60.5a	6.01d	6.01d	6.22d
5	154	61.2	18.2	49.1b	6.67c	6.75c	6.84c
7.5	147	58.2	19.0	33.8c	7.44b	7.35b	7.47b
10	161	54.8	19.9	17.6d	8.12a	7.98a	8.26a
Model <sup>x</sup>	NS	NS	NS	***	***	***	***
R <sup>2</sup>	0.16	0.28	0.13	0.96	0.99	0.97	0.99
Linear	NS	*	NS	***	***	***	***
Quadratic	NS	NS	NS	***	NS	NS	NS
Cubic	NS	NS	NS	NS	NS	NS	*

<sup>z</sup>If ANOVA was significant, means separation was performed according to LSD multiple comparison test; within columns, same letter indicates non significant difference at  $P \leq 0.05$

<sup>y</sup>initial growing medium pH was 6.3

<sup>x</sup> Significance according to ANOVA

NS, \*, \*\*, \*\*\* Non-significant, significant at  $P \leq 0.05$ ,  $P \leq 0.01$  and  $P \leq 0.001$ , respectively

R<sup>2</sup> = Coefficient of determination

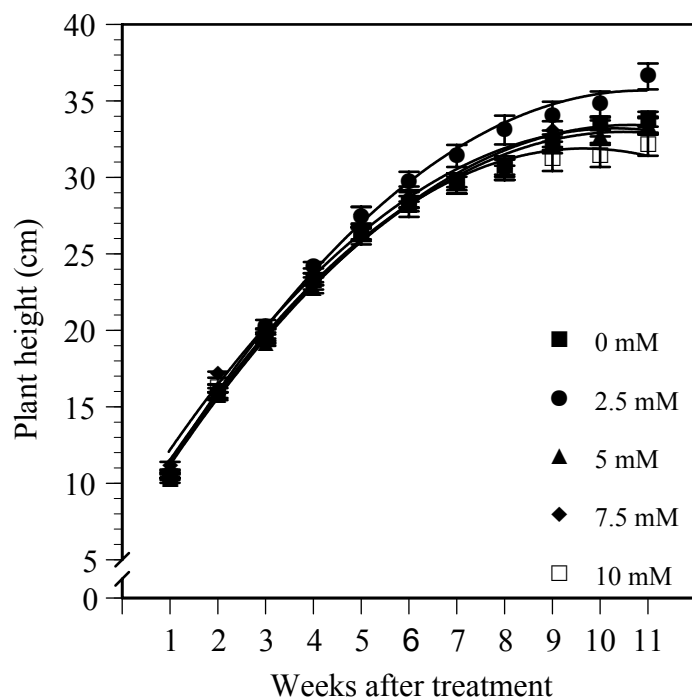

Fig. 3.3. Plant height of *Chrysanthemum morifolium* Ramat 'Miramar' plants irrigated with increasing concentrations of  $\text{NaHCO}_3$  (mM). Bars represent standard error for the mean ( $n=5$ ).

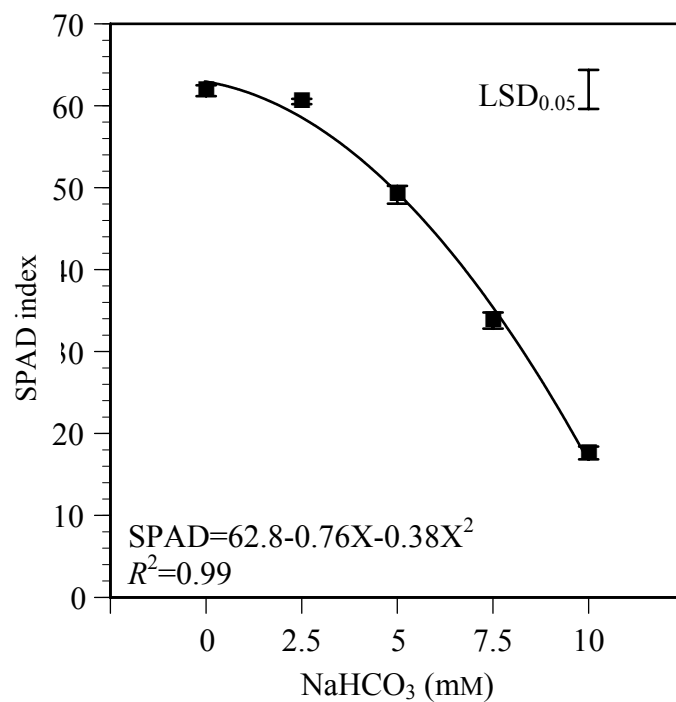

Fig. 3.4. SPAD index at final harvest of *Chrysanthemum morifolium* Ramat 'Miramar' plants irrigated with increasing concentrations of NaHCO<sub>3</sub> (mM). Bars represent standard error for the mean (n=5). LSD is the minimum significant difference at  $P \leq 0.05$ .

Table 3.3. Estimated maximum shoot dry mass and SPAD index and optimum and toxic concentrations of NaHCO<sub>3</sub> in irrigation water of *Chrysanthemum morifolium* Ramat ‘Miramar’, *Rosa* sp. L. ‘Pink Cupido’, *Catharanthus roseus* (L.) G. Don ‘Apricot Delight’, and *Hibiscus rosa-sinensis* L. Mango Breeze’ and ‘Bimini Breeze’. Optimum concentration defined as the concentration at the maximum shoot dry mass or SPAD index when ANOVA was significant; toxic concentration defined as the concentration at 15% reduction for shoot dry mass or SPAD index.

Species	Shoot Dry Mass				SPAD Index			
	Maximum dry mass (g)	NaHCO <sub>3</sub> (mM)		Model	Maximum SPAD index	NaHCO <sub>3</sub> (mM)		Model
		At Maximum	At 15% Reduction			At Maximum	At 15% Reduction	
Mums	19.9	NS <sup>z</sup>	NS	-	62.8	0	4.1	Quadratic Y=62.8-0.76X-0.38X <sup>2</sup> (R <sup>2</sup> =0.99)
Rose	12.40	0	3.0	Linear Y=12.400.62X (R <sup>2</sup> =0.94)	45.3	0	1.1	Quadratic Y=45.3-6.01X+0.40X <sup>2</sup> (R <sup>2</sup> =0.86)
Vinca	9.66	NS	NS	-	42.3	2.64	6.7	Quadratic Y=39.6+2.01X-0.38X <sup>2</sup> (R <sup>2</sup> =0.99)
Hibiscus ‘Mango Breeze’	8.74	2.95	7.3	Quadratic Y=8.16+0.40X-0.07X <sup>2</sup> (R <sup>2</sup> =0.93)	52.2	0	3.1	Linear Y=52.2-2.50X (R <sup>2</sup> =0.95)
Hibiscus ‘Bimini Breeze’	9.30	NS	NS	-	55.0	0	6.3	Linear Y=55.0-1.30X (R <sup>2</sup> =0.96)

<sup>z</sup>NS, non significant at  $P>0.05$ ; therefore, optimum and toxic concentrations can not be defined

The initial growing medium pH was 6.3. In the control treatment, 0 mM  $\text{NaHCO}_3$ , growing medium pH of the three layers decreased (Table 3.2), indicating a level of acidification of the growing medium by chrysanthemum. This is probably the result of ammonium uptake from the slow release fertilizer used in this experiment (14-14-14 Osmocote). Chrysanthemum was able to neutralize the alkalinity effect of 2.5 mM  $\text{NaHCO}_3$  since the maximum pH was 6.22 (Table 3.2). At 5 mM  $\text{NaHCO}_3$  and above, growing medium pH increased significantly ( $P \leq 0.001$ ). Increased growing medium pH followed a significant ( $P \leq 0.001$ ) linear model with increasing levels of alkalinity. Growing medium pH between layers was similar.

In conclusion, the maximum SPAD reading was obtained with no  $\text{NaHCO}_3$  in the irrigation solution and the concentration that induced toxicity was around 4.1 mM.

### **Rose**

Overall growth of rose plants was affected by increasing concentration of  $\text{NaHCO}_3$  in irrigation water (Fig. 3.1B). Plants were slightly less green with 2.5 mM  $\text{NaHCO}_3$  and an evident chlorosis appeared with 5 mM and above. Root formation was severely inhibited in plants irrigated with water containing 10 mM  $\text{NaHCO}_3$ , compared to control plants (Fig. 3.2B).

In rose, increasing the concentration of  $\text{NaHCO}_3$  in irrigation water induced a significant ( $P \leq 0.001$ ) decrease in flower and leaf number, leaf fresh and dry mass and shoot fresh and dry mass (Table 3.4). Except for flower number, the lowest  $\text{NaHCO}_3$  concentration that was significant from the control was 5 mM.

Most growth parameters were decreased in a significant linear relationship ( $P \leq 0.001$ ) (Table 3.4), indicating a high degree of sensitivity of rose to alkalinity. Analogous results were reported by Huges and Hanan (1978) in cut flower production in rose 'Forever Yours' when plants were irrigated with water containing a concentration higher than 2 mM  $\text{HCO}_3^-$ .

At harvest time, plant height was significantly decreased ( $P \leq 0.05$ ) when plants were treated with 10 mM  $\text{NaHCO}_3$  (Fig. 3.5); the tallest plants were obtained when irrigating with 0 and 2.5 mM  $\text{NaHCO}_3$ .

Table 3.4. Effect of the concentration of NaHCO<sub>3</sub> in irrigation water on shoot growth parameters, SPAD index, and growing medium pH of *Rosa* sp. L. ‘Pink Cupido’.

NaHCO <sub>3</sub> (mM)	Shoot Growth Parameters						SPAD Index	Growing Medium pH <sup>z</sup>		
	Leaf Number <sup>y</sup>	Flower Number	Leaf Fresh Mass (g)	Leaf Dry Mass (g)	Shoot Fresh Mass (g)	Shoot Dry Mass (g)		Top layer	Middle layer	Bottom layer
0	310a	16.0a	24.3a	6.71a	46.0a	11.7a	43.0a	6.25c	5.91c	6.00c
2.5	267ab	16.6a	22.9a	6.48a	45.0a	11.8a	37.5a	6.75b	7.05b	7.00b
5	245bc	13.8a	18.8b	5.30b	33.8b	9.3b	25.1b	7.50a	7.59a	7.65a
7.5	195cd	7.8b	15.2b	4.26b	28.0b	7.9b	17.8b	7.63a	7.68a	7.81a
10	142d	1.5c	10.8c	3.24c	19.1c	6.0c	27.1c	7.66a	7.61a	7.56a
Model <sup>x</sup>	***	***	***	***	***	***	***	***	***	***
R <sup>2</sup>	0.69	0.96	0.76	0.83	0.85	0.75	0.83	0.92	0.92	0.88
Linear	***	***	***	***	***	***	***	***	***	***
Quadratic	NS	***	NS	***	NS	NS	***	***	***	***
Cubic	NS	NS	NS	***	NS	NS	***	NS	NS	NS

<sup>z</sup> initial growing medium pH was 6.3

<sup>y</sup>If ANOVA was significant, means separation was performed according to LSD multiple comparison test; within columns, same letter indicates non significant difference at  $P \leq 0.05$

<sup>x</sup> Significance according to ANOVA

NS, \*, \*\*, \*\*\* Non-significant, significant at  $P \leq 0.05$ ,  $P \leq 0.01$  and  $P \leq 0.001$ , respectively

R<sup>2</sup> = Coefficient of determination



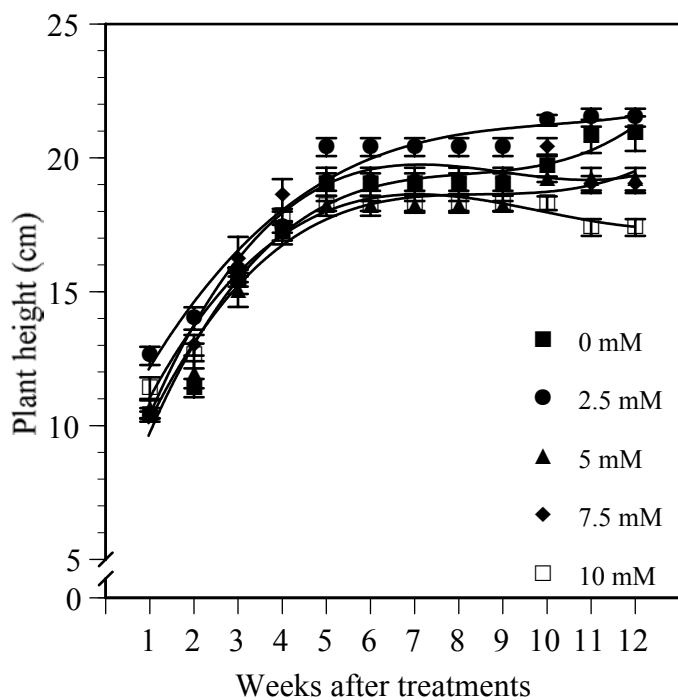

Fig. 3.5. Plant height of *Rosa* sp L. 'Pink Cupido' plants irrigated with increasing concentrations of  $\text{NaHCO}_3$  (mM). Bars represent standard error for the mean (n=5).

Shoot dry mass was significantly decreased by 20% when irrigation water contained 5 mM NaHCO<sub>3</sub>, and additional increases in the concentration caused up to a 49% decrease in dry mass (Table 3.4). According to the significant linear model (Table 3.4), the maximum shoot dry mass was 12.4 g and was obtained in plants irrigated with no NaHCO<sub>3</sub> (Table 3.3). Subtracting the 15% decrease in shoot mass required to estimate the toxic limits, the minimum mass tolerated was 10.5 g. This shoot mass was estimated to occur at 3.0 mM NaHCO<sub>3</sub>, which would be the toxic limit.

As in chrysanthemum, SPAD index was the most sensitive parameter. Compared to the control, plants irrigated with 5 mM NaHCO<sub>3</sub> showed a significant ( $P \leq 0.05$ ) 42% decrease in the SPAD index, which decreased to around 60% with 10 mM (Table 3.4). SPAD index had significant ( $P \leq 0.001$ ) linear, quadratic, and cubic relationships with the concentration of NaHCO<sub>3</sub>. The quadratic model resulted in the best description of the results obtained, a rapid decline in response to 2.5 and 5 mM NaHCO<sub>3</sub> and a gradual lower decline as the concentration increased (Fig. 3.6). According to the quadratic model, the maximum predicted SPAD index, 45.3, was obtained with no NaHCO<sub>3</sub> (Table 3.3). Subtracting the 15% decrease in SPAD index required to estimate the toxic limits, the minimum index tolerated was 38.5. This SPAD index was estimated to occur at 1.1 mM NaHCO<sub>3</sub>.

Control plants demonstrated ability to acidify the growing medium since original pH (6.30) diminished to 5.91 to 6.0 in the middle and bottom layers of the root ball (Table 3.4). As the concentration of NaHCO<sub>3</sub> increased, growing medium pH increased significantly ( $P \leq 0.001$ ) following a significant linear and quadratic response ( $P \leq 0.001$ ) (Table 3.4). Rose plants were unable to neutralize the alkalinity effect of even the lowest concentration of NaHCO<sub>3</sub> tested, 2.5 mM. The highest pH, 7.50 to 7.81, was obtained when the level of NaHCO<sub>3</sub> in water was equal to or higher than 5 mM. No difference in growing medium solution pH was detected among the three layers within each level of alkalinity. According to the results, rose plants cannot adapt to alkalinity since they did not have the capacity to acidify the growing medium.

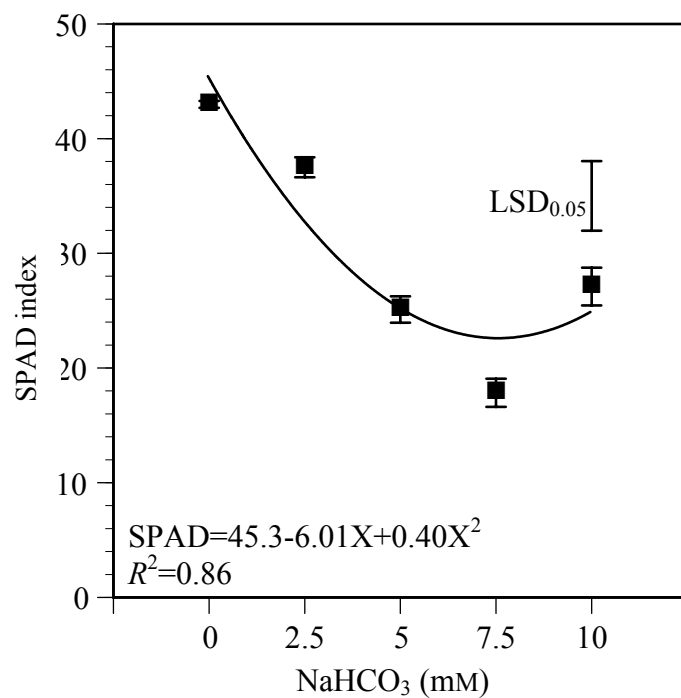

Fig. 3.6. SPAD index at final harvest of *Rosa* sp L. 'Pink Cupido' plants irrigated with increasing concentrations of NaHCO<sub>3</sub> (mM). Bars represent standard error for the mean (n=5). LSD is the minimum significant difference at  $P \leq 0.05$ .

In chrysanthemum, the SPAD index was used to determine the optimum and tolerance levels to alkalinity. In rose, both shoot growth parameters and SPAD index were sensitive and allowed determining the tolerance and toxic level. According to the models, the optimum shoot dry mass and SPAD index were attained at 0 mM NaHCO<sub>3</sub>, but toxicity occurred at 3.0 and 1.1 mM, respectively (Table 3.3). The higher concentration of NaHCO<sub>3</sub> required to reach toxicity in the shoot dry mass is of little impact since the plants would be chlorotic at this concentration. For this reason, the SPAD index is more important to identify the maximum level of alkalinity tolerated. In conclusion, the maximum SPAD reading was obtained with no NaHCO<sub>3</sub> and the concentration that induced toxicity was 1.1 mM.

### **Vinca**

Overall growth of vinca was affected by increasing concentration of NaHCO<sub>3</sub> in irrigation water (Fig. 3.1C). The plants were slightly less green at 7.5 mM and a severe chlorosis appeared with 10 mM. Root formation was severely inhibited in plants irrigated with water containing 10 mM NaHCO<sub>3</sub> compared to the control plants (Fig. 3.2C).

There was a significant ( $P \leq 0.05$ ) decrease in all leaf growth parameters as the concentration of NaHCO<sub>3</sub> increased from 0 to 2.5 mM, but additional increases in concentration did not cause further decrease in growth (Table 3.5). Despite shoot fresh and dry mass decreased with increasing concentrations of NaHCO<sub>3</sub>, the decrease was not significant. All growth parameters, except shoot dry mass, followed a significant ( $P \leq 0.05$ ) linear response to the level of NaHCO<sub>3</sub> in irrigation water. Shoot elongation was not significantly influenced by the concentration of NaHCO<sub>3</sub> (Fig. 3.7).

Similar to chrysanthemum, the severe chlorosis induced by the alkalinity made the plants not suitable for marketing (Figure 3.1C), implying that the best parameter to determine the tolerance and toxic limits was the SPAD index (Fig. 3.8). The SPAD index was significantly decreased ( $P \leq 0.001$ ) as the concentration of NaHCO<sub>3</sub> increased

Table 3.5. Effect of the concentration of NaHCO<sub>3</sub> in irrigation water on shoot growth parameters, SPAD index, and growing medium pH of *Catharanthus roseus* (L.) G. Don ‘Apricot Delight’.

NaHCO <sub>3</sub> (mM)	Shoot Growth Parameters						SPAD Index	Growing Medium pH <sup>z</sup>		
	Leaf Number <sup>y</sup>	Leaf Fresh Mass (g)	Leaf Dry Mass (g)	Leaf Area (cm <sup>2</sup> )	Shoot Fresh Mass (g)	Shoot Dry Mass (g)		Top layer	Middle layer	Bottom layer
0	534a	43.7a	5.6a	2019a	73.9	9.66	39.3ab	6.18d	6.48e	6.34d
2.5	396b	34.5b	4.2b	1501b	56.5	7.20	42.3a	7.06c	7.03d	7.14c
5	419b	37.7ab	4.5b	1390b	65.7	8.40	38.5bc	7.25b	7.29c	7.29b
7.5	382b	34.1b	4.1b	1495b	56.0	7.24	34.1c	7.59a	7.39b	7.39ab
0	371b	30.4b	3.8b	1359b	54.7	7.83	21.0d	8.11a	7.50a	7.68a
Model <sup>x</sup>	***	*	*	*	NS	NS	***	***	***	***
R <sup>2</sup>	0.48	0.35	0.41	0.37	0.33	0.26	0.86	0.82	0.72	0.80
Linear	**	**	**	**	*	NS	***	***	***	***
Quadratic	NS	NS	NS	NS	NS	NS	***	***	***	***
Cubic	NS	NS	NS	NS	NS	NS	NS	NS	NS	NS

<sup>z</sup> initial growing medium pH was 6.3

<sup>y</sup>If ANOVA was significant, means separation was performed according to LSD multiple comparison test; within columns, same letter indicates non significant difference at  $P \leq 0.05$

<sup>x</sup> Significance according to ANOVA

NS, \*, \*\*, \*\*\* Non-significant, significant at  $P \leq 0.05$ ,  $P \leq 0.01$  and  $P \leq 0.001$ , respectively

R<sup>2</sup> = Coefficient of determination

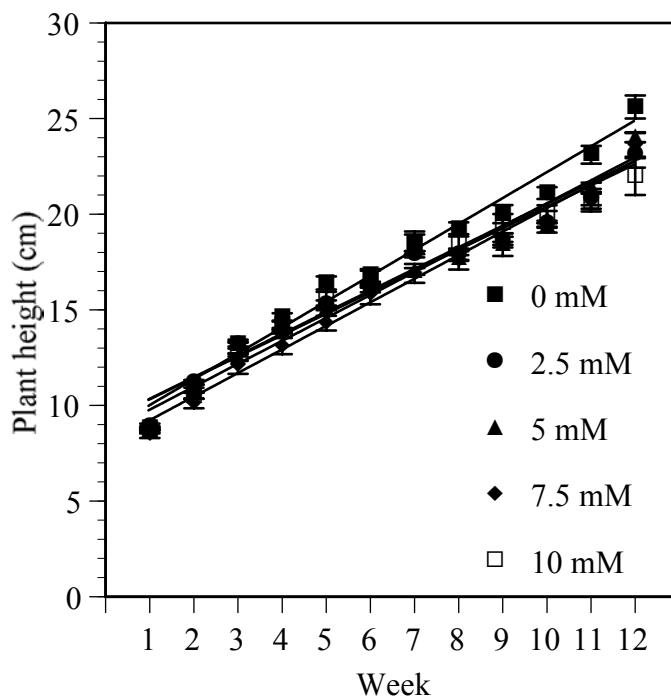

Fig. 3.7. Plant height of *Catharanthus roseus* (L.) G. Don 'Apricot Delight' plants irrigated with increasing concentrations of  $\text{NaHCO}_3$  (mM). Bars represent standard error for the mean (n=5).

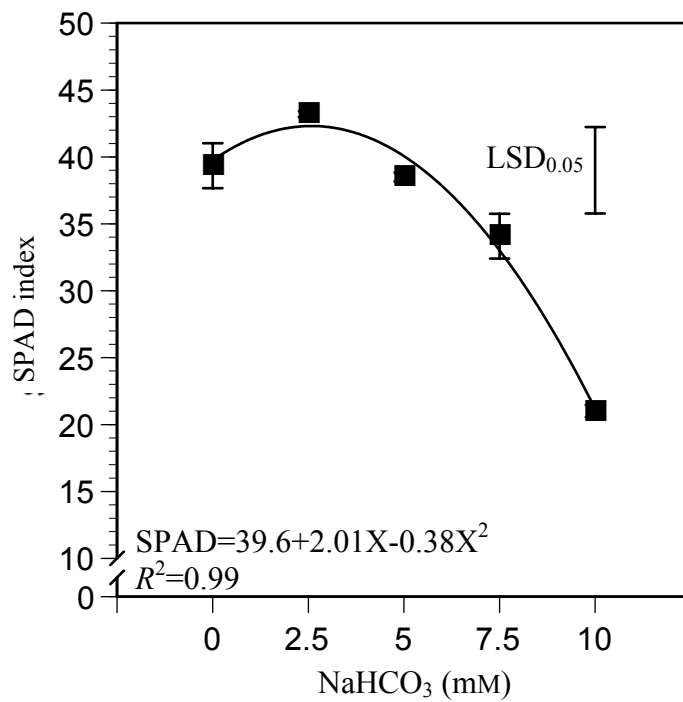

Fig. 3.8. SPAD index at final harvest of *Catharanthus roseus* (L.) G. Don 'Apricot Delight' plants irrigated with increasing concentrations of NaHCO<sub>3</sub> (mM). Bars represent standard error for the mean (n=5). LSD is the minimum significant difference at  $P \leq 0.05$ .

47% with 10 mM; however, the maximum SPAD index was observed in the 2.5 mM treatment.

SPAD index followed a significant ( $P \leq 0.001$ ) linear and quadratic decrease as the concentration of  $\text{NaHCO}_3$  in irrigation water increased (Table 3.5, Fig. 3.8). The maximum SPAD index predicted, 42.3, occurred at 2.64 mM  $\text{NaHCO}_3$  according to the quadratic model (Table 3.3), indicating that some  $\text{NaHCO}_3$  was beneficial to vinca plants. Subtracting the 15% decrease in SPAD index required to estimate the toxic limits, the minimum index tolerated was 36.0. This SPAD index was estimated to occur at 6.7 mM  $\text{NaHCO}_3$ .

Increasing  $\text{NaHCO}_3$  concentration induced a significant ( $P \leq 0.001$ ) increase in growing medium pH, which followed significant ( $P \leq 0.001$ ) linear and quadratic relationships with the levels of alkalinity assessed. Control plants did not acidify the growing medium at harvest time (Table 3.5). At any given  $\text{NaHCO}_3$  concentration, there was no difference in pH between growing medium layers, except for the treatment with 10 mM, in which the top resulted in a higher pH compared to the other layers. According to this, vinca could not neutralize the alkalinity treatments evaluated in this experiment.

In conclusion, the optimum SPAD reading was obtained with 2.64 mM  $\text{NaHCO}_3$ , and vinca showed toxicity at around 6.7 mM. The fact that vinca was able to tolerate such a high concentration of  $\text{NaHCO}_3$  even though it did not show the capacity to acidify the growing medium, suggests that mechanisms other than acidification, permit the adaptation of this plant to alkalinity.

### **Hibiscus**

Overall growth of hibiscus ‘Mango Breeze’ (Fig. 3.1D) and ‘Bimini Breeze’ (Fig. 3.1E) was slightly affected by increasing concentrations of  $\text{NaHCO}_3$  in water. For hibiscus ‘Mango Breeze’, the plants were slightly less green with 5 mM  $\text{NaHCO}_3$ , and a severe chlorosis appeared with 7.5 mM. In hibiscus ‘Bimini Breeze’, plants exhibited chlorosis with 10 mM  $\text{NaHCO}_3$ . Root growth was significantly more affected in hibiscus



'Mango Breeze' than in 'Bimini Breeze' in plants irrigated with water containing 10 mM NaHCO<sub>3</sub> compared to the control (Fig. 3.2D and E). Apparently, plants of both cultivars showed a greater root mass under high alkalinity compared to chrysanthemum, rose, and vinca.

Hibiscus 'Mango Breeze' exhibited a slight but significant ( $P \leq 0.05$ ) increase in growth parameters such as leaf fresh mass and shoot fresh and dry mass, when irrigated with solutions containing 2.5 and 5 mM NaHCO<sub>3</sub> (Table 3.6). A concentration between 0 to 5 mM did not significantly alter the response of leaf number, leaf dry mass and leaf area. With 7.5 and 10 mM solutions, leaf growth parameters were significantly decreased ( $P \leq 0.05$ ). All growth parameters exhibited significant ( $P \leq 0.05$ ) linear and quadratic responses to increasing concentrations of NaHCO<sub>3</sub> in irrigation water. At 2.5 and 5 mM NaHCO<sub>3</sub>, there was an increase in leaf fresh mass, and shoot fresh and dry mass, compared to the control. Thus, hibiscus 'Mango Breeze' benefited from limited amounts of alkalinity. The positive effect of alkalinity may be due to the buffer capacity of HCO<sub>3</sub><sup>-</sup>, which prevents sudden changes in growing medium solution pH and changes in solubility of nutrients (Bailey, 1996).

For hibiscus 'Bimini Breeze', results indicated that the concentrations of NaHCO<sub>3</sub> tested did not significantly affect most growth parameters, except for leaf number (Table 3.7). This was similar to results in chrysanthemum and was in marked contrast to the effect of NaHCO<sub>3</sub> on hibiscus 'Mango Breeze', suggesting that hibiscus 'Bimini Breeze' is more tolerant to high levels of NaHCO<sub>3</sub>.

The difference between hibiscus cultivars was also evident in plant height. Plant height was significantly diminished ( $P \leq 0.05$ ) when irrigation water contained 10 mM NaHCO<sub>3</sub> in hibiscus 'Mango Breeze' (Fig. 3.9A) compared to 2.5 mM. The difference in plant height was not significant in hibiscus 'Bimini Breeze' (Fig. 3.9B).

Increasing the concentration of NaHCO<sub>3</sub> significantly decreased ( $P \leq 0.001$ ) the SPAD index in both cultivars (Fig. 3.10). Hibiscus 'Mango Breeze' was more sensitive to the loss of green color than 'Bimini Breeze', as demonstrated by the slope of the regression equation, -2.5 and -1.3, respectively (Fig. 3.10).

Table 3.6. Effect of the concentration of NaHCO<sub>3</sub> in irrigation water on shoot growth parameters, SPAD index, and growing medium pH of *Hibiscus rosa-sinensis* L. ‘Mango Breeze’.

NaHCO <sub>3</sub> (mM)	Shoot Growth Parameters						SPAD Index	Growing Medium pH <sup>z</sup>		
	Leaf Number <sup>y</sup>	Leaf Fresh Mass (g)	Leaf Dry Mass (g)	Leaf Area (cm <sup>2</sup> )	Shoot Fresh Mass (g)	Shoot Dry Mass (g)		Top layer	Middle layer	Bottom layer
0	95.0a	24.7b	4.63a	840ab	43.5b	7.90bc	50.1a	5.64e	5.28e	5.21e
2.5	96.2a	30.9a	5.33a	1022a	54.3a	9.28a	49.3a	6.49d	5.64d	5.51d
5	92.0a	30.6a	4.81a	982a	52.7a	8.32ab	39.9b	7.61c	7.00c	7.12c
7.5	75.6b	24.7b	3.37b	708b	47.3ab	6.96c	31.1c	7.98b	8.04b	8.60b
10	61.8c	21.4b	2.90b	647b	39.0b	5.59d	27.4c	8.61a	8.42a	9.09a
Model <sup>x</sup>	***	***	***	***	***	***	***	***	***	***
R <sup>2</sup>	0.68	0.49	0.74	0.48	0.47	0.69	0.79	0.97	0.98	0.98
Linear	***	*	***	NS	NS	***	***	***	***	***
Quadratic	*	**	**	*	**	**	NS	**	NS	NS
Cubic	NS	NS	*	NS	NS	NS	NS	NS	***	***

<sup>z</sup> initial growing medium pH was 6.3

<sup>y</sup>If ANOVA was significant, means separation was performed according to LSD multiple comparison test; within columns, same letter indicates non significant difference at  $P \leq 0.05$

<sup>x</sup> Significance according to ANOVA

NS, \*, \*\*, \*\*\* Non-significant, significant at  $P \leq 0.05$ ,  $P \leq 0.01$  and  $P \leq 0.001$ , respectively

R<sup>2</sup> = Coefficient of determination

Table 3.7. Effect of the concentration of NaHCO<sub>3</sub> in irrigation water on shoot growth parameters, SPAD index, and growing medium pH of *Hibiscus rosa-sinensis* L. ‘Bimini Breeze’.

NaHCO <sub>3</sub> (mM)	Shoot Growth Parameters						SPAD Index	Growing Medium pH <sup>z</sup>		
	Leaf Number <sup>y</sup>	Leaf Fresh Mass (g)	Leaf Dry Mass (g)	Leaf Area (cm <sup>2</sup> )	Shoot Fresh Mass (g)	Shoot Dry Mass (g)		Top layer	Middle layer	Bottom layer
0	75.4bc	24.0	5.05	678	45.3	8.87	54.2a	5.32d	5.09d	4.87c
2.5	89.8a	23.5	4.98	759	46.3	9.30	51.6a	6.29c	6.04c	5.73c
5	81.4ab	23.4	4.04	669	48.3	8.05	50.1ab	7.67b	7.53b	7.28b
7.5	82.8ab	29.4	4.60	823	52.9	8.39	46.3b	8.17a	8.61a	8.73a
10	62.9c	30.3	4.54	785	56.7	8.65	41.2c	8.48a	8.69a	8.73a
Model <sup>x</sup>	***	NS	NS	NS	NS	NS	***	***	***	***
R <sup>2</sup>	0.46	0.13	0.23	0.26	0.25	0.15	0.79	0.98	0.94	0.90
`	NS	**	NS	NS	*	NS	***	***	***	***
Quadratic	**	NS	NS	NS	NS	NS	NS	***	**	NS
Cubic	NS	NS	NS	NS	NS	NS	NS	*	*	*

<sup>z</sup> initial growing medium pH was 6.3

<sup>y</sup>If ANOVA was significant, means separation was performed according to LSD multiple comparison test; within columns, same letter indicates non significant difference at  $P \leq 0.05$

<sup>x</sup> Significance according to ANOVA

NS, \*, \*\*, \*\*\* Non-significant, significant at  $P \leq 0.05$ ,  $P \leq 0.01$  and  $P \leq 0.001$ , respectively

R<sup>2</sup> = Coefficient of determination

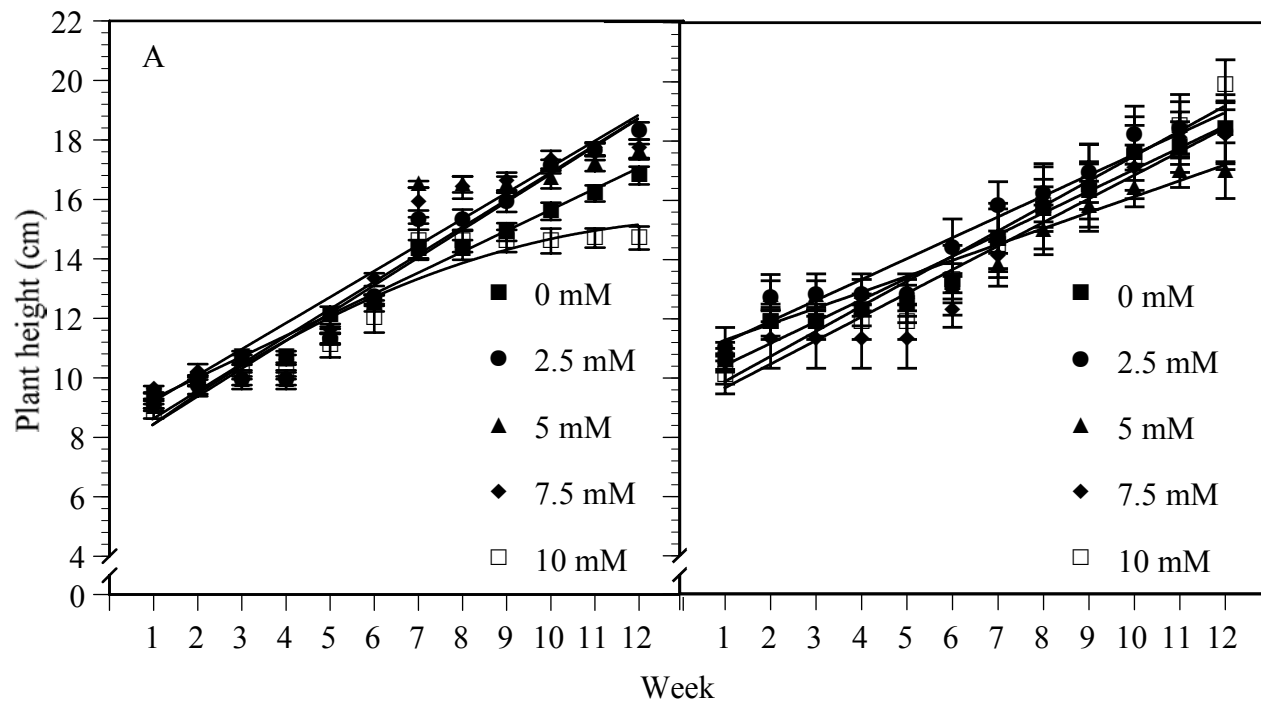

Fig. 3.9. Plant height of *Hibiscus rosa-sinensis* L. 'Mango Breeze' (A) and 'Bimini Breeze' (B) irrigated with increasing concentrations of  $\text{NaHCO}_3$  (mM). Bars are the standard error of the mean (n=5).

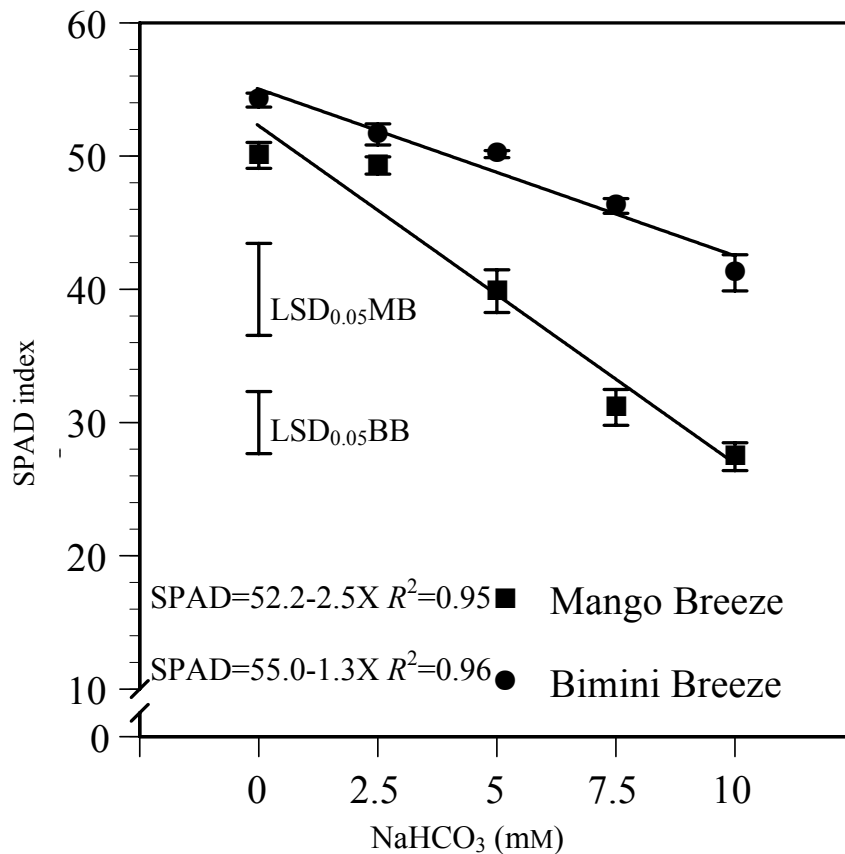

Fig.3.10. SPAD index at final harvest of *Hibiscus rosa-sinensis* L. 'Mango Breeze' and 'Bimini Breeze' irrigated with increasing concentrations of NaHCO<sub>3</sub> (mM). Bars represent standard error for the mean (n=5). LSD BB and LSD MB are the minimum significant difference at  $P \leq 0.05$  for hibiscus 'Bimini Breeze' and 'Mango Breeze', respectively.

Compared to the control, hibiscus ‘Mango Breeze’ plants irrigated with 5 mM  $\text{NaHCO}_3$  showed a significant ( $P \leq 0.05$ ) 20% decrease in SPAD readings, which decreased to 45% with 10 mM (Table 3.6). In hibiscus ‘Bimini Breeze’, plants irrigated with 7.5 mM  $\text{NaHCO}_3$  showed a significant ( $P \leq 0.05$ ) 15% decrease, which decreased to 24% with 10 mM (Table 3.7).

According to the significant quadratic model for the shoot dry mass in hibiscus ‘Mango Breeze’ (Table 3.3), the maximum dry mass, 8.74 g, was obtained when irrigating with 2.95 mM  $\text{NaHCO}_3$ . Subtracting the 15% decrease in shoot mass required to estimate the toxic limit, the minimum mass tolerated was 7.4 g. This shoot mass was estimated to occur at 7.3 mM  $\text{NaHCO}_3$ . In hibiscus ‘Bimini Breeze’, shoot dry mass was not useful to determine optimum and toxic levels of  $\text{NaHCO}_3$  because there were not significant differences.

Since the models that describe the effect of the concentration of  $\text{NaHCO}_3$  on the SPAD index were linear in both cultivars, the optimum concentration was 0 mM (Table 3.3). The predicted SPAD readings at this concentration were 52.2 and 55.0 for hibiscus ‘Mango Breeze’ and ‘Bimini Breeze’, respectively (Table 3.3). Subtracting the 15% decrease in SPAD index required to estimate the toxic limits, the minimum indices tolerated were 44.4 and 46.8, which were estimated to occur at 3.1 and 6.3 mM  $\text{NaHCO}_3$ , demonstrating the higher tolerance to alkalinity in ‘Bimini Breeze’.

Similar to chrysanthemum, rose, and vinca, in hibiscus there was also the tendency to increase growing medium pH with increasing concentrations of  $\text{NaHCO}_3$  (Tables 3.6 and 3.7). Both cultivars demonstrated capacity to acidify the growing medium when irrigated with no  $\text{HCO}_3^-$ , even at a rate higher than rose, vinca, and chrysanthemum. Growing medium pH increased in the three layers as the concentration of  $\text{NaHCO}_3$  increased for both hibiscus ‘Mango Breeze’ and ‘Bimini Breeze’ (Tables 3.6 and 3.7). Both cultivars also acidified the growing medium when irrigated with 2.5 mM  $\text{NaHCO}_3$ , especially in the middle and bottom layers. When irrigated with solutions containing 5, 7.5, and 10 mM  $\text{NaHCO}_3$ , both cultivars lost the acidification ability,

especially in the bottom layer. Thus, both cultivars were able to neutralize the alkalinity effect of 2.5 mM NaHCO<sub>3</sub>, but not higher concentrations.

The higher pH in the top layer might have been caused by migration of HCO<sub>3</sub><sup>-</sup> to this section as water evaporated from growing medium surface (Reed, 1996a), but the shift in pH pattern observed when the solution contained 7.5 to 10 mM was probably due to root growth inhibition as they reached the bottom section in which NaHCO<sub>3</sub> was building up (Fig. 3.2D and E). The decrease in root mass shown in Fig. 3.2D and E would explain the loss of acidification of the growing medium.

Growing medium pH showed significant ( $P \leq 0.01$ ) linear and quadratic increases for the top layer while it was linear and cubic for the middle and bottom layers ( $P \leq 0.001$ ) for hibiscus 'Mango Breeze' (Table 3.6). These relationships were linear, quadratic, and cubic in the top and middle layers for 'Bimini Breeze', while they were linear and cubic in the bottom layer (Table 3.7). Summarizing, both hibiscus 'Mango Breeze' and 'Bimini Breeze' had the ability to neutralize the alkalinity of 2.5 mM NaHCO<sub>3</sub>.

In rose, the parameter used to determine its level of tolerance to alkalinity was the SPAD index since shoot dry mass was considered of little importance if it were not combined with a lower incidence in leaf chlorosis. This argument also applies to hibiscus 'Mango Breeze' since both shoot dry mass and SPAD index showed similar responses. In hibiscus 'Bimini Breeze' SPAD index was the best parameter since the shoot dry mass was not affected significantly. According to the models, the optimum SPAD index, is attained at 0 mM NaHCO<sub>3</sub> in both cultivars, but toxicity occurred at 3.1 and 6.1 mM in hibiscus 'Mango Breeze' and 'Bimini Breeze', respectively. The fact that the toxicity appeared at twice as large a concentration of NaHCO<sub>3</sub> in hibiscus 'Bimini Breeze', indicates that 'Bimini Breeze' is more tolerant to alkalinity than 'Mango Breeze'.

## CONCLUSIONS

The highest SPAD readings predicted by the models in chrysanthemum, rose, and hibiscus 'Mango Breeze' and 'Bimini Breeze' were observed with no alkalinity in irrigation water. In vinca, the model predicted the highest SPAD with 2.64 mM  $\text{NaHCO}_3$ . Considering a loss of 15% in predicted SPAD as the minimum SPAD tolerated to declare the toxicity limits, chrysanthemum tolerated up to 4.1 mM, rose up to 1.1 mM, vinca up to 6.7 mM, hibiscus 'Mango Breeze' up to 3.1 mM, and hibiscus 'Bimini Breeze' up to 6.3 mM  $\text{NaHCO}_3$ .



## CHAPTER IV

### RESPONSE OF TWO CULTIVARS OF HIBISCUS (*Hibiscus rosa-sinensis* L.) TO ALKALINITY IN IRRIGATION WATER

#### INTRODUCTION

The response to alkalinity in irrigation water in two cultivars of hibiscus was evaluated in Chapter III. The results indicated that hibiscus 'Bimini Breeze' was more tolerant than hibiscus 'Mango Breeze' since a 15% decrease in SPAD index was obtained with 6.3 and 3.1 mM NaHCO<sub>3</sub>, respectively. An additional experiment with two cultivars of hibiscus was conducted in sphagnum peat moss-based growing medium to further investigate the differences between hibiscus cultivars in tolerance to alkalinity. For the present experiment, hibiscus 'Mango Breeze' was substituted by 'Carolina Breeze'.

In previous experiments, the growing medium had a pH adjusted with lime to neutralize the acidity of peat moss. Due to the strong buffering capacity of lime and the reserve acidity of the growing medium, the increase of growing medium pH by irrigating with water containing high alkalinity occurred at a slower rate. Over time, growing medium pH will be increased, but at least for the first few weeks, the plants will grow under a pH that may not be detrimental for growth. To determine the direct and immediate response of hibiscus to alkalinity it would be desirable to use a growing medium with no buffering capacity. Hydroponic solutions have minimal buffering capacity, and for this reason another experiment was carried out in such a system.

#### MATERIALS AND METHODS

##### Experiment 4.1. Determination of Tolerance and Toxic Limits of Alkalinity of Hibiscus Grown in Sphagnum Peat-Based Growing Medium

Hibiscus (*Hibiscus rosa-sinensis* L.) 10-12.5 cm (4-5 inch) liners (Yoder Brothers, Inc., Salinas Ca.) were transplanted into a sphagnum peat moss-based growing medium on 2 Nov. 2000 and plants were harvested on 9 Feb. 2001. The cultivars used

were hibiscus 'Bimini Breeze' and 'Carolina Breeze'. Plants were grown in a glass greenhouse at Texas A&M University, College Station, TX. Average temperature and relative humidity was 25<sup>0</sup>/13<sup>0</sup>C daytime/nighttime and 65%, respectively.

The containers, growing medium, initial growing medium pH, and leaching fraction were the same as described in Chapter III. After transferring the plants to the pots, the plants were allowed to establish for one week, after which irrigation started with solutions containing NaHCO<sub>3</sub> treatments. A 0.5 to 1 cm soft pinch was carried out two weeks after transplanting.

Alkalinity in irrigation solutions were prepared by dissolving NaHCO<sub>3</sub> at concentrations of 0, 2.5, 5, 7.5, and 10 mM in reverse osmosis water. The resulting average pH values were 7.21, 8.28, 8.51, 8.61, and 8.65, respectively. Irrigation solutions were prepared 24 h before required use to allow pH stabilization. Every irrigation was carried out with the respective NaHCO<sub>3</sub> solutions, allowing a leaching fraction between 0.2 to 0.3.

The experimental design was a completely randomized factorial design with 5 replications. One pot with one plant was used per replication. Data were analyzed by ANOVA (SAS Institute, Inc., N.C.). The LSD multiple range test was used as a best estimate of differences between means for parameters that showed a significant F test. Linear, quadratic, and cubic effects were also determined by using orthogonal contrasts.

The parameters measured were: plant height and leaf number on a weekly basis, total and newly-formed leaves, total leaf area and newly formed leaf area, SPAD index of newly-formed leaves, total leaf dry mass and dry mass of newly-formed leaves, total shoot and root dry mass, shoot:root ratio, root dry mass and growing medium pH in the top, middle, and bottom layers. Root dry mass was determined as follows: the container medium was separated in three horizontal layers: top third, middle third and bottom third. Roots were separated from the growing medium in each layer, then blotted dry, and dried in an oven at 75<sup>0</sup>C for 72 h and dry mass determined. Growing medium pH and SPAD index were measured similarly as described in Chapter III. Leaf area was

determined with the Portable Area Meter (Li-Cor LI-3000<sup>®</sup>, Li-Cor Biosciences, Lincoln, Ne.).

Maximum shoot dry mass, SPAD index, and toxic concentrations of NaHCO<sub>3</sub> were estimated according to the model that best fit the results, similar as was done in Chapter III.

#### **Experiment 4.2. Determination of Tolerance and Toxic Limits of Alkalinity of Hibiscus Grown in Hydroponics**

Hibiscus liners were grown in aerated hydroponics solutions in a controlled environment growing room (Environmental Growth Chambers, OH; Model M96-10-5K-0750A-277/480). Temperature was set at 27<sup>0</sup>C daytime and 16<sup>0</sup>C nighttime, average relative humidity was 60%. Day length was 0700 HR to 1900 HR. During the daytime, the average PAR was 480 μmol·m<sup>-2</sup>·s<sup>-1</sup>.

Individual 10-12.5cm (4-5 inch) cuttings (Yoder Brothers, Inc., Salinas Ca.) were transplanted on 3 Nov. 2000 and plants harvested on 14 Dec. 2000. Five plants of the same cultivar were suspended in styrofoam floats in 9-L plastic containers containing the respective nutrient solution. Filtered air was bubbled constantly in the nutrient solution of each container (1PH pump, Model 2Z866, Dayton Electric MFG Co., Chicago IL.). Containers were covered with a bicolor plastic sheet in order to prevent light from reaching nutrient solutions and subsequent algae growth. Treatments started as soon as plants were transferred to the containers.

The complete nutrient solution contained 15 mM N (80% NO<sub>3</sub><sup>-</sup> -N and 20% NH<sub>4</sub><sup>+</sup> -N), 1 mM P, 6 mM K, 4.5 mM Ca, 2 mM Mg, 4.5 mM S, 5 mg·L<sup>-1</sup> of Fe (Fe-DTPA), 0.02 mg·L<sup>-1</sup> Cu, 0.5 mg·L<sup>-1</sup> B, 0.11 mg·L<sup>-1</sup> Mo, and 0.65 mg·L<sup>-1</sup> Mn (Table A1, Appendix). The solutions were prepared with Ca(NO<sub>3</sub>)<sub>2</sub>·4H<sub>2</sub>O, (NH<sub>4</sub>)<sub>2</sub>SO<sub>4</sub>, KNO<sub>3</sub>, CaSO<sub>4</sub>·2H<sub>2</sub>O, KH<sub>2</sub>PO<sub>4</sub>, MgSO<sub>4</sub>·7H<sub>2</sub>O, Fe-DTPA, CuSO<sub>4</sub>·5H<sub>2</sub>O, ZnSO<sub>4</sub>·5H<sub>2</sub>O, (NH<sub>4</sub>)<sub>6</sub>Mo<sub>7</sub>O<sub>24</sub>·4H<sub>2</sub>O, MnSO<sub>4</sub>·H<sub>2</sub>O and H<sub>3</sub>BO<sub>3</sub> (Annex 1). The concentrations of NaHCO<sub>3</sub> were 0, 2.5, 5, 7.5, and 10 mM. Nutrient solutions were prepared with nanopure water, replenished as needed, and changed every week.

The parameters measured were: solution pH, leaf dry mass and area, SPAD index, shoot dry mass, root dry mass, shoot:root ratio, root diameter, root volume, root length, root surface area, and Fe-reductase activity. Leaf dry mass and area, SPAD index, and shoot and root dry mass were measured as indicated in Chapter III and experiment 4.1. Solution pH was measured on a daily basis for the first 17 days of the experiment using the TwinpH<sup>®</sup> meter (Spectrum Technologies, Inc., Plainfield, Ill.). To obtain root diameter, volume, length, and surface area, the roots were scanned and the image was analyzed by the program WinRHIZO<sup>™</sup> v4.1b (Reagent Instruments, Inc., Que., Canada).

The experiment consisted of 5 plants in each container, thus the replications were nested within the treatments. Data were analyzed using ANOVA (SAS Institute, Inc., N.C.) as well as linear, quadratic, and cubic effects. The model contained the nested factors. The LSD multiple range test was used as a best estimate of differences between means for parameters that showed a significant F test,.

The Fe-reductase assay was performed on entire roots according to Rosenfield et al. (1991). The root systems of five intact plants were immersed in 250 ml of a continuously aerated buffer solution consisting of 0.1 mM FeEDTA, 5 mM MES (2-[N-Morpholino]ethanesulfonic acid), 0.5 mM CaSO<sub>4</sub>, and 0.3 mM BPDS (4,7-Diphenyl-1,10-phenantrolinedisulfonic acid). The containers were painted black in order to prevent light from reaching the solution. The reaction was carried out at 21°C and under greatly reduced light to avoid photo reduction. The reaction was allowed to occur for 60 min, after which a sample of the solution was drawn and its absorbance was estimated by spectrophotometer (Bausch and Lomb Spectrophotometer 21<sup>®</sup> Model UVD, Bausch and Lomb, N.Y) at 535 nM. The readings were compared to a standard curve prepared with Fe<sup>2+</sup> and the data expressed as  $\mu\text{M Fe}\cdot\text{g}^{-1}$  of root dry mass $\cdot\text{h}^{-1}$

## RESULTS

### Experiment 4.1. Determination of Tolerance and Toxic Limits of Alkalinity of Hibiscus Grown in Sphagnum Peat-Based Growing Medium

#### *Shoot growth*

Overall growth of hibiscus ‘Bimini Breeze’ and ‘Carolina Breeze’ (Fig. 4.1) was slightly affected by increasing concentrations of  $\text{NaHCO}_3$  in irrigation water. Hibiscus ‘Bimini Breeze’ plants were slightly less green at 7.5 mM  $\text{NaHCO}_3$ , and a very significant chlorosis was observed in plants treated with 10 mM. Hibiscus ‘Carolina Breeze’ plants showed a noted chlorosis with 5 mM  $\text{NaHCO}_3$  and higher.

There was not a significant effect of  $\text{NaHCO}_3$  concentration on plant height (Table 4.1, Fig. 4.2A), leaf number (Table 4.1, Fig. 4.3A), leaf area (Table 4.1), total shoot dry mass, and leaf dry mass (Table 4.2) of hibiscus ‘Bimini Breeze’. In contrast, there was a significant decrease in total leaf dry mass, and shoot:root ratio as the concentration of  $\text{NaHCO}_3$  increased (Table 4.2).

All the shoot growth and SPAD index measurements decreased significantly with increasing concentrations of  $\text{NaHCO}_3$ , except plant height, for hibiscus ‘Carolina Breeze’, (Table 4.1 and 4.2, Fig. 4.2B and 4.3B). Several of the responses followed significant linear and quadratic models. Newly-formed leaves, leaf area, leaf dry mass, and shoot dry mass showed significant quadratic models, indicating that very low concentrations of  $\text{NaHCO}_3$  enhanced the parameters and higher levels caused a decrease.

These observations indicated a high level of tolerance of hibiscus ‘Bimini Breeze’ to  $\text{NaHCO}_3$ -induced alkalinity and a greater sensitivity of hibiscus ‘Carolina Breeze’. Results also showed a slight beneficial effect of low and moderate concentrations of  $\text{NaHCO}_3$  in hibiscus ‘Carolina Breeze’.

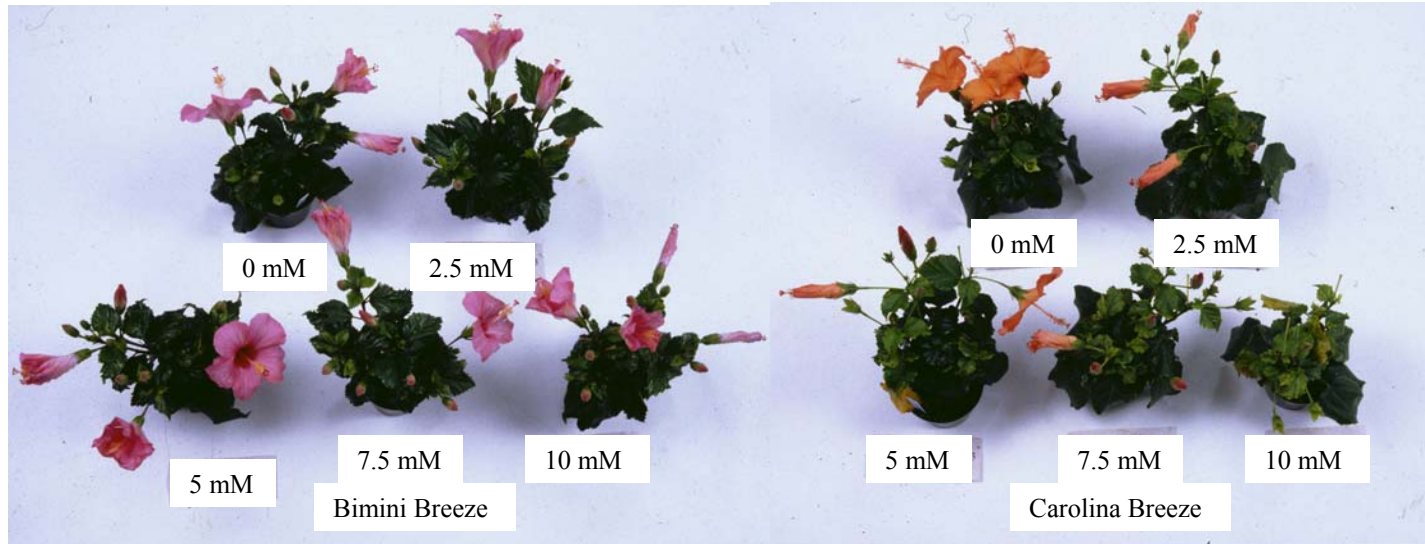

Fig. 4.1. Effect of the concentration of  $\text{NaHCO}_3$  in irrigation water on general appearance of *Hibiscus rosa-sinensis* L. 'Bimini Breeze' (left) and 'Carolina Breeze' (right)

Table 4.1. Effect of the concentration of NaHCO<sub>3</sub> (mM) in irrigation water on growth parameters of *Hibiscus rosa-sinensis* L. ‘Bimini Breeze’ (BB) and ‘Carolina Breeze’ (CB).

NaHCO <sub>3</sub> (mM)	Final Plant Height (cm)		Total Leaf Number <sup>z</sup>		Newly Formed Leaves Number		Total Leaf Area (cm <sup>2</sup> )		Leaf Area Newly Formed Leaves (cm <sup>2</sup> )	
	BB	CB	BB	CB	BB	CB	BB	CB	BB	CB
	0	20.2	19.2	72.4	63.0ab	57.8	45.6bc	846	848ab	544ab
2.5	21.6	19.2	76.8	65.0a	60.6	50.6ab	904	912a	565a	470ab
5	19.8	20.2	69.0	68.0a	55.0	55.0a	848	951a	517ab	551a
7.5	19.8	17.4	77.0	57.0b	57.6	40.4cd	922	753bc	594a	336c
10	19.0	18.2	76.0	63.8ab	54.0	35.4d	735	679c	476b	315c
Linear	NS	NS	NS	NS	NS	***	NS	***	NS	*
Quadratic	NS	NS	NS	NS	NS	***	NS	**	NS	**
Cubic	NS	NS	NS	*	NS	NS	NS	NS	NS	NS
Cultivar <sup>y</sup>	*		***		***		NS		***	
NaHCO <sub>3</sub>	NS		NS		*		**		**	
Interaction	NS		**		**		NS		**	
R <sup>2</sup>	0.33		0.63		0.66		0.40		0.67	

<sup>z</sup>If ANOVA was significant, means separation was performed according to LSD multiple comparison test; within columns, same letter indicates non significant difference at  $P \leq 0.05$

<sup>y</sup>Significance according to ANOVA

NS, \*, \*\*, \*\*\* Non-significant, significant at  $P \leq 0.05$ ,  $P \leq 0.01$  and  $P \leq 0.001$ , respectively

R<sup>2</sup> = Coefficient of determination

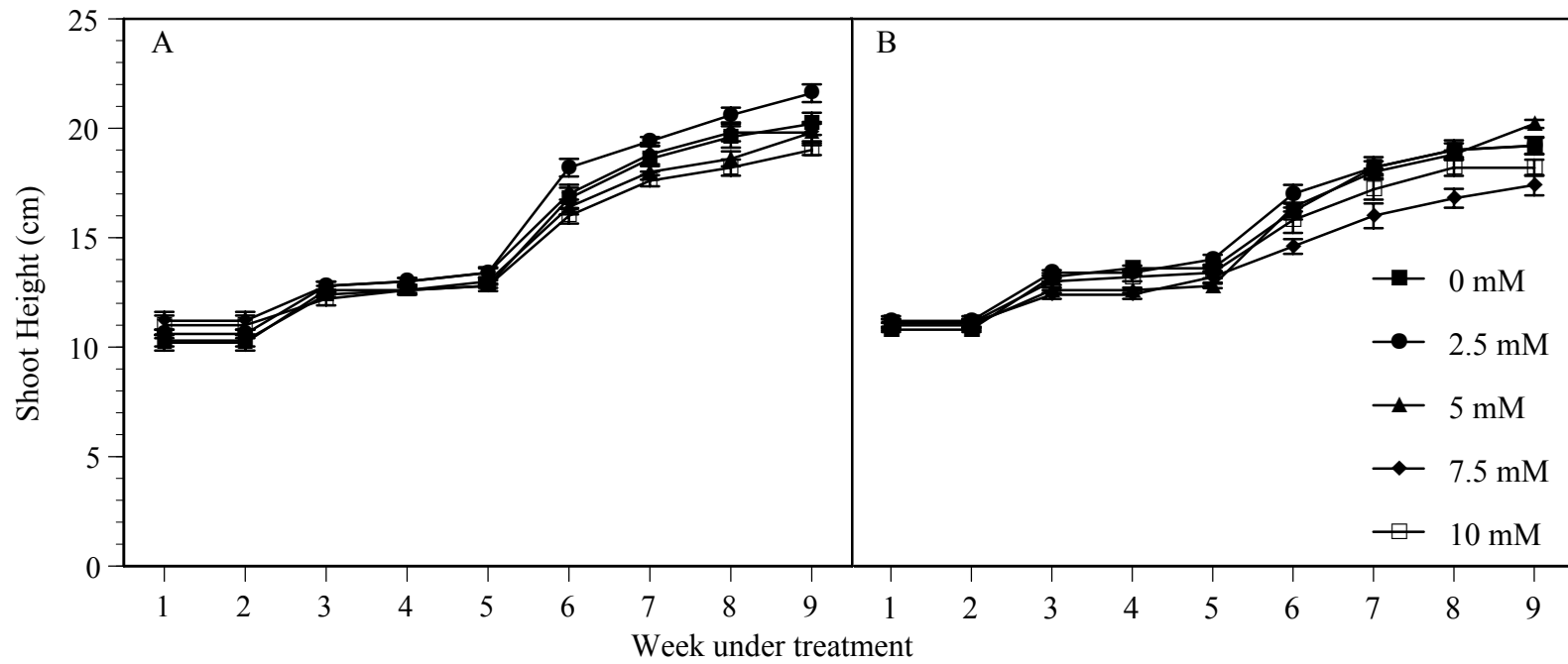

Fig. 4.2. Shoot height of *Hibiscus rosa-sinensis* L. 'Bimini Breeze' (A) and 'Carolina Breeze' (B) plants irrigated with increasing concentrations of  $\text{NaHCO}_3$  (mM). Bars represent standard error for the mean (n=5).



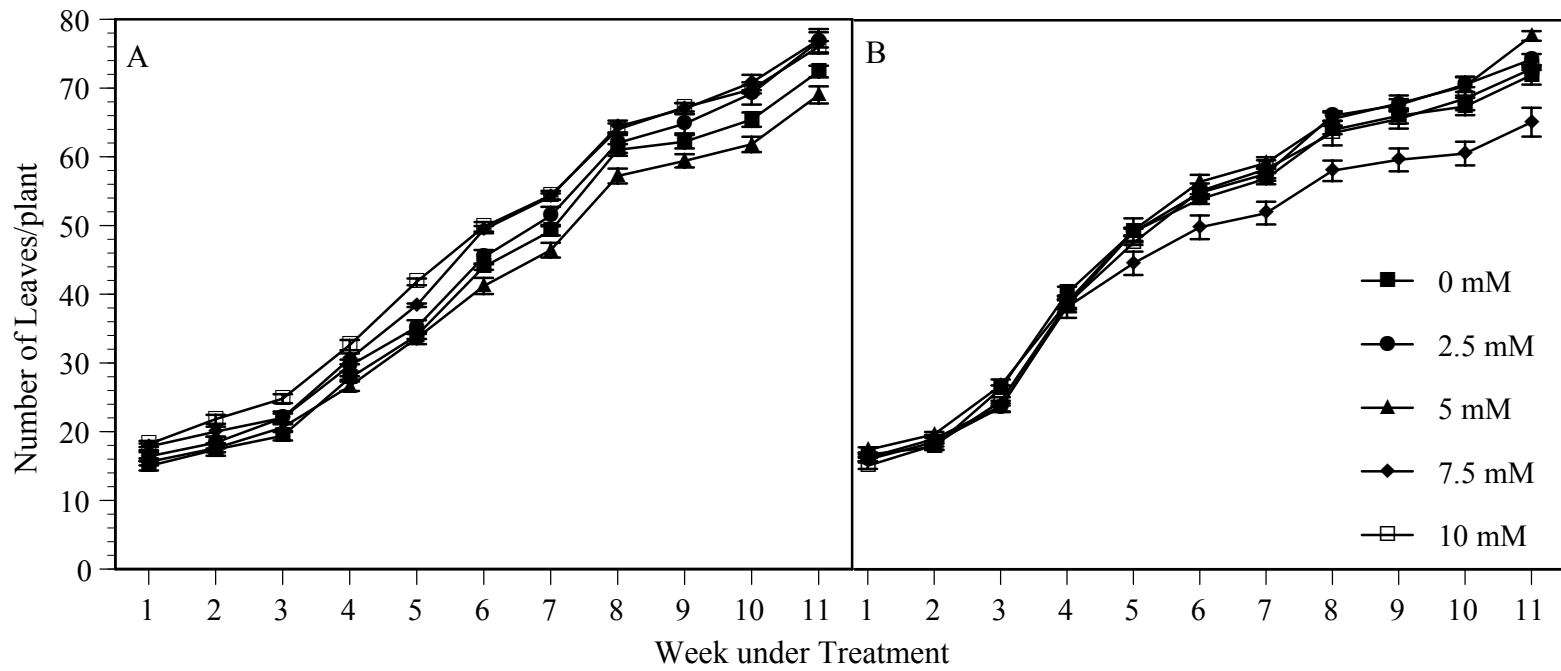

Fig. 4.3. Number of leaves at final harvest of *Hibiscus rosa-sinensis* L. 'Bimini Breeze' (A) and 'Carolina Breeze' (B) plants irrigated with increasing concentrations of  $\text{NaHCO}_3$  (mM). Bars represent standard error for the mean (n=5).

Table 4.2. Effect of the concentration of NaHCO<sub>3</sub> (mM) in irrigation water on SPAD index and growth parameters of *Hibiscus rosa-sinensis* L. ‘Bimini Breeze’ (BB) and ‘Carolina Breeze’ (CB).

NaHCO <sub>3</sub> (mM)	SPAD Index <sup>z</sup>		Total Leaf Dry Mass (g)		Dry Mass of New Leaves (g)		Total Shoot Dry Mass (g)		Total Root Dry Mass (g)		Shoot:Root Ratio (g·g <sup>-1</sup> )	
	BB	CB	BB	CB	BB	CB	BB	CB	BB	CB	BB	CB
0	63.2a	60.2a	6.75	6.88ab	4.37	3.09bc	14.21	12.83ab	5.95a	6.39a	2.23d	2.10b
2.5	61.1ab	55.4a	6.85	7.40a	4.00	3.66ab	13.85	13.49a	6.27a	5.22b	2.43d	2.59ab
5	56.8bc	47.1b	6.32	7.20a	3.72	3.95a	12.64	12.83ab	4.41b	4.57bc	2.92c	2.81a
7.5	54.0c	38.6c	6.52	6.01bc	4.12	2.52c	13.59	11.04b	3.72bc	3.95c	3.69b	2.80a
10	37.3d	32.6d	5.58	5.31c	3.64	2.39c	12.00	9.20c	2.89c	3.89c	4.16a	2.42ab
Linear	***	***	*	***	NS	**	NS	***	***	***	***	NS
Quadratic	***	NS	NS	**	NS	**	NS	*	NS	NS	*	**
Cubic	*	NS	NS	NS	NS	NS	NS	NS	NS	NS	*	NS
Cultivar <sup>y</sup>	***		NS		***		*		NS		***	
NaHCO <sub>3</sub>	***		***		**		***		***		**	
Interaction	**		NS		**		NS		NS		**	
R <sup>2</sup>	0.90		0.47		0.61		0.53		0.71		0.86	

<sup>z</sup>If ANOVA was significant, means separation was performed according to LSD multiple comparison test; within columns, same letter indicates non significant difference at  $P \leq 0.05$

<sup>y</sup>Significance according to ANOVA

NS, \*, \*\*, \*\*\* Non-significant, significant at  $P \leq 0.05$ ,  $P \leq 0.01$  and  $P \leq 0.001$ , respectively

R<sup>2</sup> = Coefficient of determination

### *Root growth*

Root growth was dramatically affected by the concentration of  $\text{NaHCO}_3$  in irrigation water (Fig. 4.4). Increasing concentrations of  $\text{NaHCO}_3$  induced a more severe decrease in root mass in hibiscus ‘Bimini Breeze’ than in ‘Carolina Breeze’ (Fig. 4.4.).

Total root dry mass was significantly ( $P \leq 0.05$ ) decreased in both cultivars, especially at concentrations higher than 5 mM in Bimini Breeze and 2.5 mM in Carolina Breeze (Table 4.2). The interaction of cultivar\* $\text{NaHCO}_3$  concentration was not significant implying that both cultivars showed a parallel linear decrease in root growth. Data showed that at a low concentration of  $\text{NaHCO}_3$ , 2.5 mM, the decrease in root mass for hibiscus ‘Bimini Breeze’ was lower than for hibiscus ‘Carolina Breeze’, 5% and 18%, respectively. At higher concentrations, 5 and 7.5 mM, both cultivars exhibited similar decreases in root growth, 26% to 36% in Bimini Breeze, and 28% to 37% in Carolina Breeze. At the highest  $\text{NaHCO}_3$  concentration, 10 mM, the decrease in root mass was 51% for hibiscus ‘Bimini Breeze’ and 39% for ‘Carolina Breeze’.

Root mass was greatest in the bottom, then middle, then top layer for both cultivars (Table 4.3). In relative terms, dry mass of roots in the middle and bottom layers was more affected in hibiscus ‘Bimini Breeze’ than in hibiscus ‘Carolina Breeze’. Compared to the control, root mass of plants treated with 10 mM  $\text{NaHCO}_3$  was decreased 52%, 41%, and 59% in the top, middle, and bottom layers, respectively, for hibiscus ‘Bimini Breeze’, and 61%, 20%, and 43%, respectively, for hibiscus ‘Carolina Breeze’.

### *Shoot:root ratio*

The shoot:root ratio of hibiscus ‘Carolina Breeze’ increased slightly but significantly ( $P \leq 0.05$ ) in plants irrigated with solutions containing greater than 5 mM  $\text{NaHCO}_3$  (Table 4.2). There was a similar tendency for hibiscus ‘Bimini Breeze’, but the ratio increased up to 87% in plants grown with 10 mM  $\text{NaHCO}_3$ , while in hibiscus ‘Carolina Breeze’ the increase was up to 34% in plants irrigated with 5 mM.

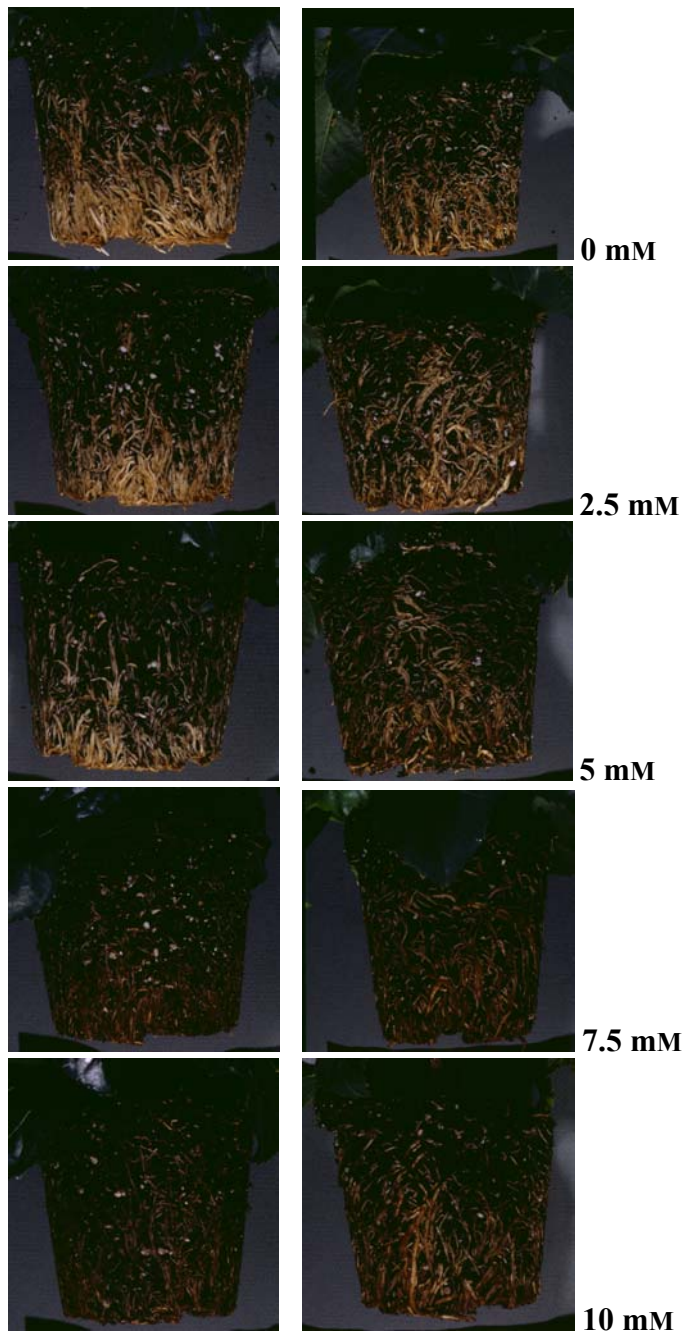

**'Bimini Breeze'**      **'Carolina Breeze'**

Fig 4.4. Effect of the concentration of NaHCO<sub>3</sub> in irrigation water on root growth of *Hibiscus rosa-sinensis* L 'Bimini Breeze' (left column) and 'Carolina Breeze' (right column).

Table 4.3. Effect of the concentration of NaHCO<sub>3</sub> (mM) in irrigation water on root growth parameters and growing medium pH of the top, middle, and bottom layer of *Hibiscus rosa-sinensis* L. ‘Bimini Breeze’ (BB) and ‘Carolina Breeze’ (CB).

NaHCO <sub>3</sub> (mM)	Root Dry Mass <sup>z</sup> (g)						Growing Medium pH <sup>y</sup>					
	Top Layer		Middle Layer		Bottom Layer		Top		Middle		Bottom	
	BB	CB	BB	CB	BB	CB	BB	CB	BB	CB	BB	CB
0	1.16a	1.29a	2.03ab	2.10a	2.76a	3.00a	5.60e	5.41e	4.99e	5.43e	4.76e	5.36e
2.5	1.06ab	0.89b	2.50a	2.00a	2.71a	2.34b	6.86d	6.73d	6.51d	6.72d	5.77d	6.44d
5	0.76bc	0.70b	1.56bc	1.95ab	2.09b	1.92c	7.53c	7.68c	7.30c	7.39c	7.18c	7.52c
7.5	0.54c	0.62b	1.49bc	1.44b	1.68bc	1.89c	8.03b	8.07b	7.90b	8.12b	7.96b	8.55b
10	0.56c	0.50b	1.19c	1.69ab	1.14c	1.70c	8.78a	8.81a	8.24a	8.87a	8.48a	9.48a
Linear	***	***	***	*	***	***	***	***	***	***	***	***
Quadratic	NS	NS	NS	NS	NS	*	*	***	***	*	***	NS
Cubic	NS	NS	NS	NS	NS	NS	NS	***	*	NS	*	NS
Cultivar <sup>x</sup>	NS		NS		NS		NS		***		***	
NaHCO <sub>3</sub>	***		***		***		***		***		***	
Interaction	NS		NS		NS		NS		NS		NS	
R <sup>2</sup>	0.54		0.46		0.72		0.97		0.97		0.98	

<sup>z</sup>If ANOVA was significant, means separation was performed according to LSD multiple comparison test; within columns, same letter indicates non significant difference at  $P \leq 0.05$

<sup>y</sup>Initial growing medium pH was 6.3

<sup>x</sup>Significance according to ANOVA

NS, \*, \*\*, \*\*\* Non-significant, significant at  $P \leq 0.05$ ,  $P \leq 0.01$  and  $P \leq 0.001$ , respectively

R<sup>2</sup> = Coefficient of determination

The increase in the shoot:root ratio followed a linear, quadratic, and cubic responses for hibiscus ‘Bimini Breeze’ ( $P \leq 0.05$ ), while for hibiscus ‘Carolina Breeze’ the response was quadratic ( $P \leq 0.01$ ).

#### *Growing medium pH*

The initial growing medium pH was 6.3. Both cultivars acidified the growing medium in the control treatment by 0.70 to 1.54 pH units for hibiscus ‘Bimini Breeze’, and by 0.87 to 0.94 units for hibiscus ‘Carolina Breeze’ (Table 4.3). As the concentration of  $\text{NaHCO}_3$  increased, the pH of all layers increased in both cultivars. At the highest concentration tested, 10 mM, the pH of all layers increased about 1.9 to 3.2 pH units compared to the initial pH. Neither cultivar was able to acidify the growing medium enough to counteract even the lowest concentration of  $\text{NaHCO}_3$  tested, 2.5 mM, but it was lower in hibiscus ‘Bimini Breeze’ compared to ‘Carolina Breeze’.

#### *SPAD index*

The SPAD reading showed a significant decrease ( $P \leq 0.05$ ) (Fig. 4.5) for both cultivars with a concentration equal to or higher than 5 mM  $\text{NaHCO}_3$  (Table 4.2). SPAD index followed a linear decrease, with a slope of -2.88 units per mM  $\text{NaHCO}_3$  for hibiscus ‘Carolina Breeze’ (Fig. 4.5); for hibiscus ‘Bimini Breeze’, a quadratic model explained the decrease in SPAD index.

#### *Toxic concentrations of $\text{NaHCO}_3$*

Table 4.4 shows the maximum predicted shoot and root dry mass, as well as the SPAD index. The models estimated that maximum shoot and root mass for hibiscus ‘Bimini Breeze’ was obtained at 0 mM  $\text{NaHCO}_3$ , while the maximum SPAD index was at 1.27 mM. For hibiscus ‘Carolina Breeze’, maximum shoot mass was obtained at 2.21 mM and the maximum root mass and SPAD index were at 0 mM.

The 15 % decrease used to determine the toxic limit indicated that the shoot mass was affected at 11.4 mM and 7.5 mM  $\text{NaHCO}_3$  for hibiscus ‘Bimini Breeze’ and ‘Carolina Breeze’, respectively, indicating a higher tolerance in ‘Bimini Breeze’. Root growth in hibiscus ‘Bimini Breeze’ was more sensitive since a 15% decrease was estimated at 1.21 mM, while for hibiscus ‘Carolina Breeze’ it was at 1.58 mM.

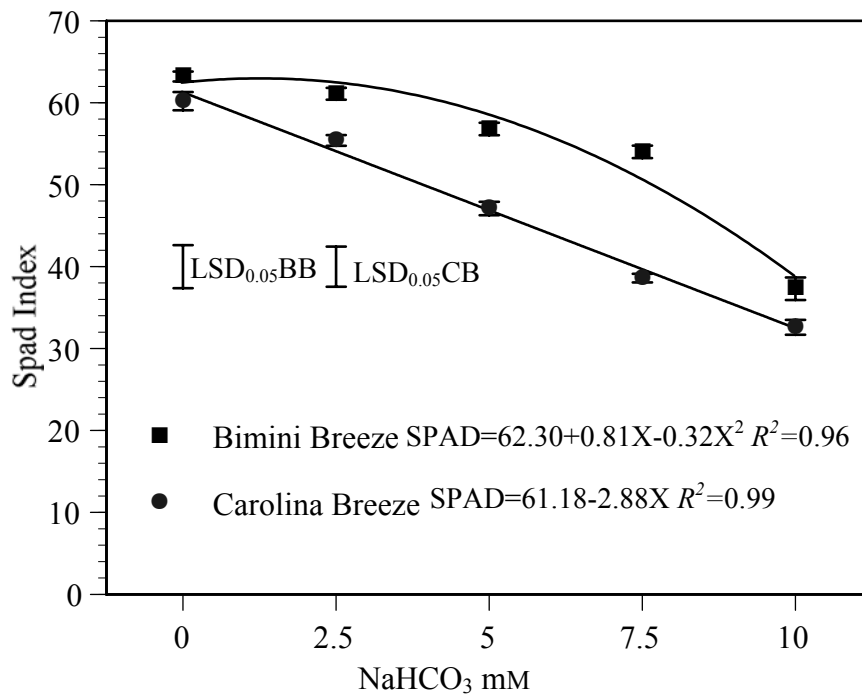

Fig. 4.5. SPAD index at final harvest of *Hibiscus rosa-sinensis* L. ‘Bimini Breeze’ and ‘Carolina Breeze’ plants irrigated with increasing concentrations of NaHCO<sub>3</sub>. Bars represent the standard error for the mean. LSD<sub>0.05</sub> is the minimum significant difference for hibiscus ‘Bimini Breeze’ (BB) and Carolina Breeze’ (CB) respectively, at  $P \leq 0.05$ .

Table 4.4. Estimated maximum shoot dry mass, root dry mass, and SPAD index, and optimum and toxic concentration of NaHCO<sub>3</sub>. Optimum concentration defined as the concentration at the maximum shoot dry mass or SPAD index when ANOVA was significant; toxic concentration defined as the concentration at 15% reduction for shoot dry mass or SPAD index.

Parameter	Cultivar	Maximum	Concentration of NaHCO <sub>3</sub> mM at maximum	15% Reduction	Concentration of NaHCO <sub>3</sub> (mM) at 15% reduction	Model
Shoot Dry Mass (g)	'Bimini Breeze'	14.2	0	12.1	11.4	Linear Y=14.2-0.19X R <sup>2</sup> =0.66
	'Carolina Breeze'	13.3	2.21	11.3	7.5	Quadratic Y=12.9+0.31X-0.07X <sup>2</sup> R <sup>2</sup> =0.99
Root Dry Mass (g)	'Bimini Breeze'	7.3	0	6.2	1.21	Linear Y=7.3-0.87X R <sup>2</sup> =0.90
	'Carolina Breeze'	6.7	0	5.7	1.58	Linear Y=6.7-0.63X R <sup>2</sup> =0.91
SPAD Index	'Bimini Breeze'	62.8	1.27	53.4	6.7	Quadratic Y=62.30+0.81X-0.32X <sup>2</sup> R <sup>2</sup> =0.96
	'Carolina Breeze'	61.2	0	52.0	3.0	Linear Y=61.2-2.88X R <sup>2</sup> =0.96



The decrease in SPAD index was calculated to occur at 6.7 and 3.0 mM NaHCO<sub>3</sub> for hibiscus ‘Bimini Breeze’ and ‘Carolina Breeze’ respectively, also indicating the higher tolerance to alkalinity in ‘Bimini Breeze’.

#### **Experiment 4.2. Determination of Tolerance and Toxic Alkalinity Limits of Hibiscus Plants Grown in Hydroponics**

##### *General appearance*

Both cultivars exhibited decreased shoot and root growth as the concentration of NaHCO<sub>3</sub> increased (Fig. 4.6). Plants showed severe chlorosis when grown in solutions containing 5 mM NaHCO<sub>3</sub> and higher concentrations. Roots exhibited a darker color when treated with increasing concentrations of NaHCO<sub>3</sub>.

##### *Shoot growth*

All shoot growth parameters measured for both cultivars were decreased by increasing concentrations of NaHCO<sub>3</sub> in nutrient solution (Table 4.5 and 4.6). Decreased shoot growth was linear for both cultivars. For most growth parameters, hibiscus ‘Bimini Breeze’ grown at 5 mM and higher concentrations showed significant decreases ( $P \leq 0.05$ ). Significant decreases ( $P \leq 0.05$ ) were measured at 2.5 mM for hibiscus ‘Carolina Breeze’ (Table 4.5).

##### *Root growth*

Root growth responded similarly to shoot growth (Table 4.5)(Fig. 4.6). Increasing levels of alkalinity caused a significant decrease in all root growth parameters measured, except for root diameter in both cultivars for concentrations equal to and above 5 mM. The decrease in root growth was predominantly linear for both cultivars.

Hibiscus ‘Bimini Breeze’ was much more sensitive to NaHCO<sub>3</sub> since the decrease in root mass at 10 mM was around 80%, compared to the control, whereas the loss was of 39% for hibiscus ‘Carolina Breeze’. Hibiscus ‘Carolina Breeze’ roots had a higher root volume compared to hibiscus ‘Bimini Breeze’ (Table 4.5). Compared to the control, the decrease in volume was significant ( $P \leq 0.05$ ) for hibiscus ‘Carolina Breeze’ at 10 mM NaHCO<sub>3</sub>, and for hibiscus ‘Bimini Breeze’ at 5 mM.



Table 4.5. Effect of the concentration of NaHCO<sub>3</sub> (mM) in nutrient solution on shoot and root growth parameters of *Hibiscus rosa-sinensis* L. ‘Bimini Breeze’ (BB) and ‘Carolina Breeze’ (CB).

NaHCO <sub>3</sub> (mM)	Leaf Area <sup>z</sup> (cm <sup>2</sup> )		SPAD index		Leaf Dry Mass (g)		Shoot Dry Mass (g)		Root Dry Mass (g)		Shoot:Root Ratio (g:g <sup>-1</sup> )	
	BB	CB	BB	CB	BB	CB	BB	CB	BB	CB	BB	CB
	0	507a	540a	69.0ab	69.2a	3.90a	4.43a	6.77a	7.88a	1.29a	1.31a	4.26b
2.5	428ab	418b	74.1a	66.9a	3.44a	3.26b	6.35a	6.30b	1.10a	1.17a	4.84b	4.42a
5	289bc	272c	58.5b	56.7b	1.89b	1.96c	3.66b	4.29c	0.65b	1.09ab	4.77b	3.06b
7.5	191cd	186d	38.4c	23.2c	1.34b	1.39c	3.02bc	3.10c	0.61b	0.81b	4.32b	2.84b
10	131d	169d	39.2c	26.5c	0.96b	1.38c	2.08c	3.19c	0.26b	0.80b	6.83a	3.09b
Linear	***	***	***	***	***	***	***	***	***	***	***	***
Quadratic	NS	*	NS	NS	NS	**	NS	*	NS	NS	*	**
Cubic	NS	NS	**	***	NS	NS	NS	NS	NS	NS	*	NS
Cultivar <sup>y</sup>	***		***		***		***		***		***	
NaHCO <sub>3</sub>	***		***		***		***		***		**	
Interaction	***		*		**		***		***		***	
R <sup>2</sup>	0.92		0.89		0.94		0.95		0.96		0.94	

<sup>z</sup>If ANOVA was significant, means separation was performed according to LSD multiple comparison test; within columns, same letter indicates non significant difference at  $P \leq 0.05$

<sup>y</sup>Significance according to ANOVA

NS, \*, \*\*, \*\*\* Non-significant, significant at  $P \leq 0.05$ ,  $P \leq 0.01$  and  $P \leq 0.001$ , respectively

R<sup>2</sup> = Coefficient of determination

Table 4.6. Effect of the concentration of NaHCO<sub>3</sub> (mM) in nutrient solution on root growth parameters and Fe-reductase activity of *Hibiscus rosa-sinensis* L. ‘Bimini Breeze’ (BB) and ‘Carolina Breeze’ (CB).

NaHCO <sub>3</sub> (mM)	Root Volume (cm <sup>3</sup> ) <sup>z</sup>		Root Length (cm)		Root Surface Area (mm <sup>2</sup> )		Root Diameter (mm)		Fe-Reductase Activity (μM Fe <sup>3+</sup> ·g <sup>-1</sup> dry mass·h <sup>-1</sup> )		Fe-Reductase Activity (μM Fe <sup>3+</sup> ·mm <sup>-2</sup> ·h <sup>-1</sup> × 10 <sup>-3</sup> )	
	BB	CB	BB	CB	BB	CB	BB	CB	BB	CB	BB	CB
0	11.7a	15.0a	2646a	1950a	615a	600a	0.71	0.99c	3.59c	5.95a	7.45b	12.77a
2.5	9.9ab	14.8a	2269a	1477b	522a	520ab	0.74	1.14bc	6.02b	5.26ab	12.63b	11.87a
5	6.1bc	14.0a	1318b	1132b	317b	443b	0.75	1.24b	4.45bc	2.65c	9.18b	6.51b
7.5	6.3bc	10.6a	1160bc	655c	303b	290c	0.82	1.49a	5.77b	2.07c	11.60b	5.84b
10	2.5c	9.6a	564c	642c	131c	276c	0.76	1.33ab	10.86a	3.44bc	22.20a	9.78ab
Linear	***	*	***	***	***	***	NS	***	***	**	***	*
Quadratic	NS	NS	NS	NS	NS	*	NS	NS	**	*	*	*
Cubic	NS	NS	NS	NS	NS	NS	NS	NS	**	NS	*	NS
Cultivar <sup>y</sup>	***		***		***		***		***		***	
NaHCO <sub>3</sub>	***		***		***		***		***		NS	
Int. <sup>x</sup>	NS		***		***		***		***		NS	
R <sup>2</sup>	0.81		0.96		0.89		0.96		0.95		0.92	

<sup>z</sup>If ANOVA was significant, means separation was performed according to LSD multiple comparison test; within columns, same letter indicates non significant difference at  $P \leq 0.05$

<sup>y</sup>Significance according to ANOVA

<sup>x</sup> Int.=Interaction

NS, \*, \*\*, \*\*\* Non-significant, significant at  $P \leq 0.05$ ,  $P \leq 0.01$  and  $P \leq 0.001$ , respectively

R<sup>2</sup> = Coefficient of determination

Concentrations of 5 mM NaHCO<sub>3</sub> induced a significant ( $P \leq 0.05$ ) decrease in root length in hibiscus ‘Bimini Breeze’, while in hibiscus ‘Carolina Breeze’ the decrease was at 2.5 mM (Table 4.6). Root surface area was significantly ( $P \leq 0.05$ ) decreased at 5 mM and above in both cultivars (Table 4.6).

Contrary to the parameters above cited, root diameter increased as the concentration of NaHCO<sub>3</sub> increased (Table 4.6). This increase in diameter was significant ( $P \leq 0.05$ ) for hibiscus ‘Carolina Breeze’ plants grown in solutions with 5, 7.5, and 10 mM NaHCO<sub>3</sub>. Roots of hibiscus ‘Bimini Breeze’ did not increase significantly ( $P > 0.05$ ) in diameter as the NaHCO<sub>3</sub> concentration increased. At the highest concentration evaluated, 10 mM, roots diameter increased by 34% for hibiscus ‘Carolina Breeze’ compared to the control treatment.

In general, root growth of hibiscus ‘Bimini Breeze’ seemed to be much more sensitive to alkalinity because, excluding root diameter, root growth parameters decreased 79% on average, whereas for Carolina Breeze this decrease was between 34% and 67%.

#### *Shoot:root ratio*

An opposite response of the shoot:root ratio was observed between cultivars (Table 4.5). Compared to the control plants, this parameter was significantly increased ( $P \leq 0.05$ ) when hibiscus ‘Bimini Breeze’ plants were grown in a solution containing 10 mM NaHCO<sub>3</sub>. For hibiscus ‘Carolina Breeze’ the ratio decreased ( $P \leq 0.05$ ).

#### *Solution pH*

Both cultivars demonstrated the ability to acidify the nutrient solution (Fig. 4.7). The decrease in solution pH was about 2 units in the 0 mM NaHCO<sub>3</sub> control, 1 unit in the 2.5 mM NaHCO<sub>3</sub> treatment, and about 0.5 unit in the 5 mM NaHCO<sub>3</sub> concentration. Thus, both cultivars could partially overcome the effect of NaHCO<sub>3</sub> on solution pH. Neither cultivar was able to prevent the alkalinity-induced pH increase at 7.5 and 10 mM.

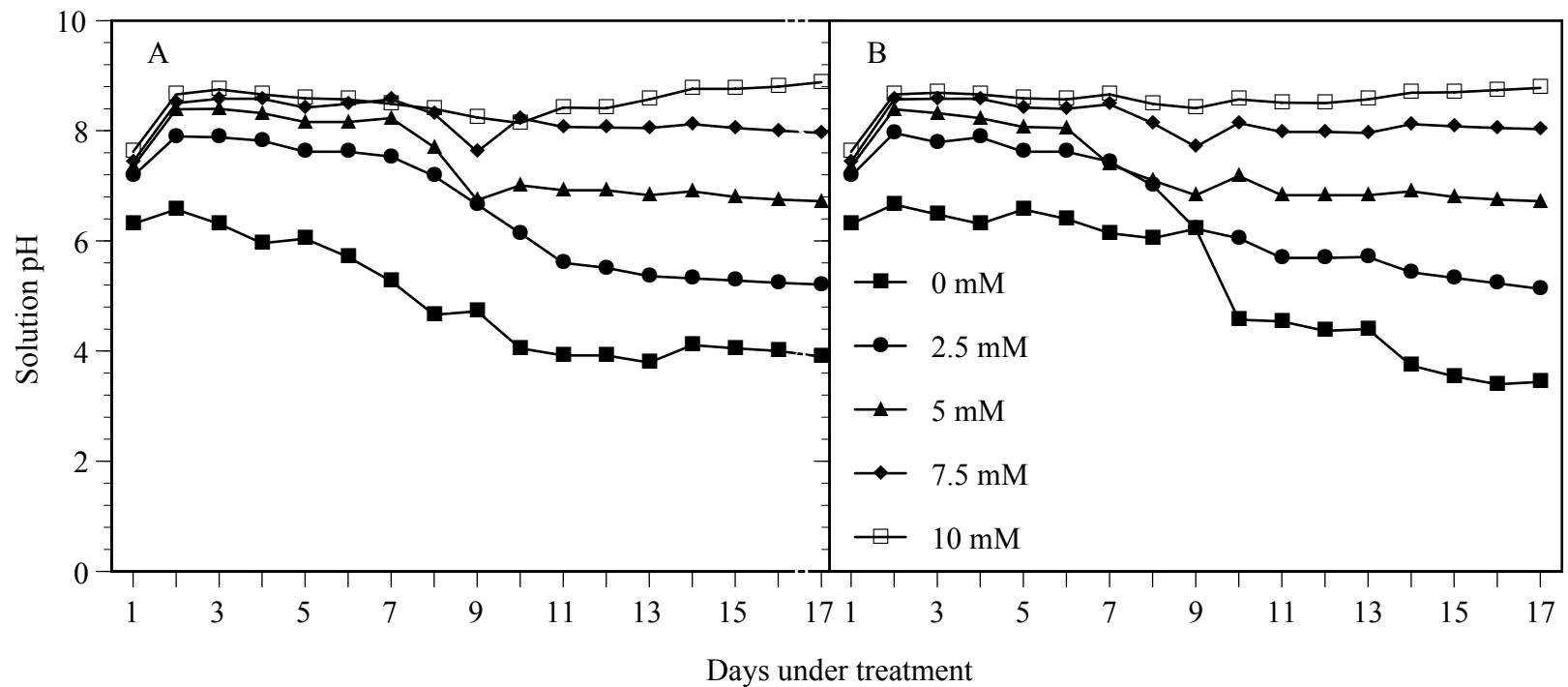

Fig. 4.7. Solution pH of *Hibiscus rosa-sinensis* L. 'Bimini Breeze' (A) and 'Carolina Breeze' (B) plants grown in hydroponics with increasing concentrations of  $\text{NaHCO}_3$  (mM).

### *Fe-reductase activity*

Iron-reductase activity was significantly affected in both hibiscus 'Carolina Breeze' ( $P \leq 0.01$ ) and hibiscus 'Bimini Breeze' ( $P \leq 0.001$ ) by the concentration of  $\text{NaHCO}_3$  in nutrient solution (Table 4.6). For hibiscus 'Carolina Breeze', reductase activity decreased as the concentration of  $\text{NaHCO}_3$  increased (Fig. 4.8). For hibiscus 'Bimini Breeze', the activity increased significantly ( $P \leq 0.05$ ) when  $\text{NaHCO}_3$  concentration increased and there was a greatly enhanced activity at 10 mM (Fig. 4.8).

### *SPAD index*

As indicated by SPAD index, leaves green color decreased with increasing concentrations of  $\text{NaHCO}_3$  in nutrient solution (Table 4.5, Fig 4.9). Concentrations of 5 mM  $\text{NaHCO}_3$  caused a significant ( $P \leq 0.05$ ) decrease in the SPAD index of both cultivars (Table 4.5). The most dramatic decrease in SPAD index occurred at 7.5 and 10 mM  $\text{NaHCO}_3$ . Compared to control plants, SPAD index at 10 mM was decreased 43% and 62% for hibiscus 'Bimini Breeze' and 'Carolina Breeze', respectively.

## **DISCUSSION**

### **Shoot Growth**

In soilless medium culture, the response of both cultivars of hibiscus varied according to the concentration of  $\text{NaHCO}_3$  in irrigation water.

In general, for hibiscus 'Bimini Breeze', shoot growth was not significantly affected by the level of  $\text{NaHCO}_3$  (Table 4.1 and 4.2). For hibiscus 'Carolina Breeze', shoot growth was significantly decreased at 7.5 and 10 mM (Table 4.1 and 4.2). These results corroborate the greater tolerance of hibiscus 'Bimini Breeze' to alkalinity reported in Chapter III.

The interaction of cultivar\* $\text{NaHCO}_3$  concentration allows one to determine whether the response to  $\text{NaHCO}_3$  is different between cultivars. The interaction was significant for parameters such as leaf number, area, and dry mass formed after pinching (Table 4.1 and 4.2), demonstrating that cultivars responded differentially to alkalinity.

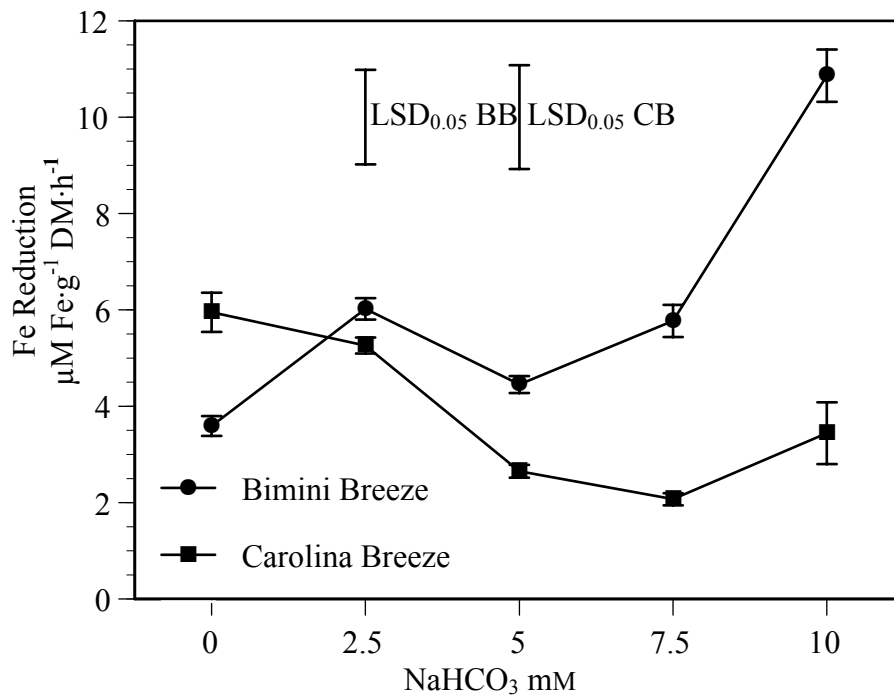

Fig. 4.8. Iron-reductase activity ( $\mu\text{M Fe}\cdot\text{g}^{-1}$  root dry mass $\cdot\text{hr}^{-1}$ ) of *Hibiscus rosa-sinensis* L. 'Bimini Breeze' and 'Carolina Breeze' grown in hydroponics with increasing concentrations of  $\text{NaHCO}_3$ . Bars represent the standard error for the mean.  $\text{LSD}_{0.05}$  is the minimum significant difference for hibiscus 'Bimini Breeze' (BB) and 'Carolina Breeze' (CB) respectively.



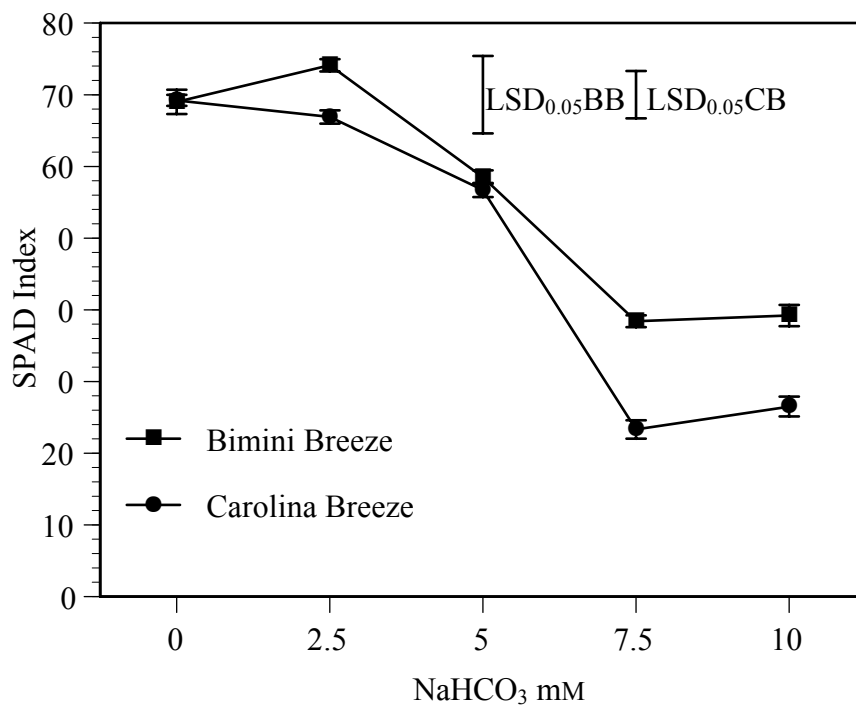

Fig. 4.9. SPAD index at final harvest of *Hibiscus rosa-sinensis* L. 'Bimini Breeze' and 'Carolina Breeze' grown in hydroponics with increasing concentrations of NaHCO<sub>3</sub> (mM). Bars represent the standard error of the mean (n=5). LSD<sub>0.05</sub> is the minimum significant difference for hibiscus 'Bimini Breeze' (BB) and Carolina Breeze' (CB) respectively.

The response in hibiscus ‘Carolina Breeze’ was predominantly a curvilinear quadratic relationship, with a slight beneficial effect at low levels of alkalinity and a significant decrease at high concentrations of  $\text{NaHCO}_3$ . The higher sensitivity and beneficial effect of intermediate levels of  $\text{NaHCO}_3$  for hibiscus ‘Carolina Breeze’ was similar to that exhibited by hibiscus ‘Mango Breeze’ described in Chapter III. Hibiscus ‘Bimini Breeze’ responded similarly as reported in Chapter III: shoot mass and other parameters showed a linear decrease (Table 4.2).

The concentration of  $\text{NaHCO}_3$  at which the maximum shoot dry mass index was obtained was 0 and 2.21 mM for hibiscus ‘Bimini Breeze’ and ‘Carolina Breeze’, respectively, indicating the positive effect of low levels of alkalinity in the latter (Table 4.4). The corresponding 15% decrease in shoot mass was estimated at 11.4 and 7.5 mM  $\text{NaHCO}_3$ , respectively, demonstrating the higher tolerance of hibiscus ‘Bimini Breeze’ to high alkalinity in irrigation water.

Parameters including leaves present in the liners when the experiment started, such as total leaf area and total leaf dry mass, did not have a significant interaction (Table 4.1 and 4.2). Reports have indicated that irrigating impatiens with water containing  $320 \text{ mg}\cdot\text{L}^{-1}$  of alkalinity (as  $\text{CaCO}_3$ ) in a peat-perlite growing medium, caused an increase in pH, from the starting 6.5 or 7.0, in four weeks; the medium pH reached the maximum level of 8.5 in eight weeks (Argo and Bierbaum, 1996). Thus, there is a period of time in which the plants grow under a non-detrimental pH. It is possible that the buffer capacity of the sphagnum peat moss-based medium used for present experiment allowed enough time for the leaves of liners to develop normally. Once the medium pH was increased due to accumulation of  $\text{HCO}_3^-$ , the development of new leaves was affected, allowing differentiation of the response between cultivars in the new growth. The interaction for total dry mass was also non-significant (Table 4.2), probably because it also included the dry mass of leaves present in the liners before the treatment effects started.

In hydroponics, a high concentration of  $\text{NaHCO}_3$  in nutrient solution induced a severe decrease in shoot growth of both cultivars (Table 4.4). This is different from the

response of plants grown in soilless medium. Nonetheless in hydroponics, hibiscus ‘Bimini Breeze’ exhibited more tolerance to alkalinity than hibiscus ‘Carolina Breeze’ since neither shoot nor leaf dry mass were affected when plants grew in solutions containing 2.5 mM  $\text{NaHCO}_3$ . In hibiscus ‘Carolina Breeze’, 2.5 mM induced a significant decrease in these parameters.

### **Root Growth**

Root growth was more affected by high alkalinity in hibiscus ‘Bimini Breeze’. Total root mass was markedly affected by increasing concentrations of  $\text{NaHCO}_3$  in plants cultivated in soilless growing medium (Table 4.2). Root mass decreased significantly with 5 mM in hibiscus ‘Bimini Breeze’ and between 2.5 to 5 mM in hibiscus ‘Carolina Breeze’. Even though hibiscus ‘Bimini Breeze’ tolerated up to 2.5 mM, this cultivar was more affected because the total decrease was 51%, compared to hibiscus ‘Carolina Breeze’, whose decrease was 39% when irrigated with 10 mM  $\text{NaHCO}_3$ .

In general, plants in all treatments concentrated more root mass in the bottom section of the container, followed by the middle and top sections (Table 4.3). The difference among layers was attenuated as the concentration of  $\text{NaHCO}_3$  increased. This is because the loss of root mass due to increasing  $\text{NaHCO}_3$  concentrations was greatest in the bottom layer.

The concentration of  $\text{NaHCO}_3$  at which the maximum root dry mass index was obtained was 0 mM in both hibiscus cultivars. This demonstrates the high sensitivity of roots to alkalinity (Table 4.4). The corresponding 15% decrease in shoot mass was estimated at 1.21 and 1.58 mM  $\text{NaHCO}_3$  in hibiscus ‘Bimini Breeze’ and ‘Carolina Breeze’, respectively. This shows that root growth in hibiscus ‘Bimini Breeze’ is slightly more sensitive to alkalinity.

In hydroponics, the decrease in root mass in hibiscus ‘Carolina Breeze’ was 39% when the nutrient solution contained 10 mM  $\text{NaHCO}_3$  (Table 4.4), which is similar to the decrease in mass of container-grown plants (Table 4.2). In hibiscus ‘Bimini Breeze’ this decrease was 80% at 10 mM. The decrease in other root growth parameters was also higher in hibiscus ‘Bimini Breeze’.

Average root diameter was unaffected in hibiscus ‘Bimini Breeze’ but in hibiscus ‘Carolina Breeze’ there was a significant increase, especially at concentrations of 7.5 and 10 mM (Table 4.5). Similar results were reported in *Lupinus angustifolius* in which it was shown that root growth was inhibited by high pH due to a decrease in cell elongation, which leads to increased root diameter (Marschner, 1995). An increase in root tip diameter has been reported for plants growing under Fe deficiency conditions, which is associated to an enhanced  $H^+$  extrusion confined to the swollen tips (Dell’Orto et al., 2002; Zouari et al., 2001). Maize, sorghum, barley (Alhendawi et al., 1997), and sugar beet plants have been reported with root diameter increases when grown in solutions containing a high concentration of  $HCO_3^-$ . The alterations in root morphology may be due to increased synthesis of ethylene (Schmidt et al., 2000) and auxins (Schikora and Schmidt, 2002; Schmidt et al., 2000). In present research, we report the average diameter of roots, not discriminating between tips or any other portion of the roots. It is possible that this is a response of hibiscus ‘Carolina Breeze’ to Fe deficiency-induced by the alkalinity.

### **Growing Medium and Solution pH**

Both cultivars acidified the growing medium in the control treatment. Hibiscus ‘Bimini Breeze’ decreased the pH by 0.7 to 1.5 units, while hibiscus ‘Carolina Breeze’ decreased pH by around 0.9 units (Table 4.3). As the concentration of  $NaHCO_3$  increased, growing medium pH of all layers increased in both cultivars. At the highest concentration tested, 10 mM, pH of all layers increased about 2.5 and 3.2 pH units in hibiscus ‘Bimini Breeze’ and ‘Carolina Breeze’ respectively, compared to the initial pH. Hibiscus ‘Bimini Breeze’ was able to acidify the growing medium enough to counteract a concentration of 2.5 mM  $NaHCO_3$  in the bottom layer. Apart from this, neither cultivar was able to acidify the growing medium.

In hydroponics, there was no difference in the acidification of the nutrient solutions between cultivars (Fig. 4.4); however, hibiscus ‘Bimini Breeze’ must have had a higher capacity for acidification since it was able to keep a pH similar to that in

hibiscus 'Carolina Breeze' with a 80% decrease in root mass; the root mass decreased by 39% in hibiscus 'Carolina Breeze'.

It has been demonstrated that increased acidification of the rhizosphere is correlated to enhanced synthesis and activity of the  $H^+$ -ATPase in the plasmalemma of root cells (Dell'Orto et al., 2002; Rabotii and Zocchi, 1994) when plants are under Fe deficiency. Acidification of the rhizosphere may also be due to the extrusion  $H^+$  coupled to  $NH_4^+$  uptake (Marschner, 1995) or  $NH_4^+$  nitrification (Havlin et al., 1999).

### **SPAD Index and Fe-Reductase Activity**

Leaves showed increased chlorosis with increasing concentrations of  $NaHCO_3$  (Table 4.2 and 4.5). The slope for the decrease in SPAD index in hibiscus 'Carolina Breeze' was very similar to the reported in hibiscus 'Mango Breeze' in Chapter III.

In soilless growing medium culture, hibiscus 'Bimini Breeze' was more tolerant to alkalinity than hibiscus 'Carolina Breeze'. The 15% decrease in SPAD index was estimated to occur at 6.7 and 3.0 mM  $NaHCO_3$  for hibiscus 'Bimini Breeze' and 'Carolina Breeze', respectively (Table 4.4). In Chapter III, the toxic limits were 6.3 and 3.1 mM for hibiscus 'Bimini Breeze' and 'Mango Breeze', which were very similar to the results observed in the present experiment. Thus, the tolerance of hibiscus 'Bimini Breeze' is confirmed in plants grown in a sphagnum peat moss-based growing medium.

Hibiscus 'Bimini Breeze' may have exhibited less chlorosis at high levels of alkalinity because it has a higher capacity to acidify the medium. The relatively more acidic medium allows greater Fe availability for plant uptake, resulting in less chlorotic plants.

In hydroponics, there were little differences between the SPAD index of the two cultivars with increasing  $NaHCO_3$  (Table 4.5). The intensity of the green color of leaves was decreased similarly in both cultivars at a concentration of 0 to 5 mM, but hibiscus 'Bimini Breeze' exhibited a 44% decrease at 7.5 mM  $NaHCO_3$ , while in hibiscus 'Carolina Breeze' the decrease was of 66%. Similarly, both cultivars did not differ in their ability for acidification of nutrient solutions. Thus, the Fe availability phenomenon that may have been involved in soilless culture was not interactive in hydroponics.

Another mechanism that may explain the increased tolerance of hibiscus 'Bimini Breeze' to  $\text{NaHCO}_3$  is an enhancement of the activity of the Fe-reductase in the roots. In hibiscus 'Bimini Breeze', as the concentration of  $\text{NaHCO}_3$  increased, Fe-reductase activity was increased significantly, reaching up to 3 times the activity in control plants (Table 4.6, Fig. 4.5). In hibiscus 'Carolina Breeze', there was a significant decrease in Fe-reductase activity as the concentration of  $\text{NaHCO}_3$  increased.

The activity of Fe-reductase increases in response to a Fe-deficiency (Li et al., 2000; Zouari et al., 2001), which results from the increased solution pH induced by  $\text{HCO}_3^-$ . Iron-efficient plants exhibit increased Fe-reductase activity when exposed to Fe deficiency or an alkalinity-induced decrease in Fe availability. These data indicated that hibiscus 'Bimini Breeze' exhibited characteristics of an Fe-efficient cultivar.

## **CONCLUSIONS**

Hibiscus 'Bimini Breeze' is more tolerant than hibiscus 'Carolina Breeze' to high levels of alkalinity in irrigation water, but 'Carolina Breeze' is benefited with small amounts of  $\text{NaHCO}_3$ . The tolerance in Bimini Breeze is due to an enhanced activity of Fe-reductase in plants grown under high levels of alkalinity and a higher acidification rate when grown in soilless medium.

## CHAPTER V

### **EFFECT OF $\text{NO}_3^-$ : $\text{NH}_4^+$ RATIO IN THE RESPONSE OF SUNFLOWER (*Helianthus annuus* L. 'Big Smile') TO ALKALINITY IN HYDROPONICS**

#### **INTRODUCTION**

Alkalinity in water used for irrigation of greenhouse crops is a major concern because of its deleterious effect on plant nutrition and growth. Addition of acids to water, management of waters with varying degrees of quality, use of substrates with acid reaction, decreases in the amount of calcite or dolomite when preparing growing medium, use of tolerant species or cultivars, adaptation of fertilization practices, etc. are some of the horticultural tools growers can utilize to deal with alkalinity in irrigation water.

The use of fertilizers with acid reaction is an excellent means for controlling moderate levels of alkalinity (Nelson, 1998). By using  $\text{NH}_4^+$ -N fertilizers it is feasible to acidify the growing medium pH (Tagliavini et al., 1995). Ammonium causes acidification by two mechanisms. In one mechanism, plant uptake of  $\text{NH}_4^+$  is coupled with the release of  $\text{H}^+$  by plants to the rhizosphere (Marschner, 1995), affecting growing medium solution pH. Conversely, the uptake of  $\text{NO}_3^-$  is associated with an increase in growing medium solution pH because it takes place through a  $\text{H}^+/\text{NO}_3^-$  co-transport (Mengel and Kirkby, 2001). In another mechanism, the conversion of  $\text{NH}_4^+$  to  $\text{NO}_3^-$  by soil-borne bacteria causes acidification.

An excess of  $\text{NH}_4^+$  fertilization can induce toxicity, as reported in celosia and snapdragon (Jeong and Lee, 1992). Some species have a high tolerance for  $\text{NH}_4^+$ , such as ageratum and lobelia (Jeong and Lee, 1992), and pecan (Kim et al., 2002). The  $\text{NH}_4^+$  toxicity is caused by an excessive acidification of the growing medium solution, which in turn reduces the  $\text{H}^+$  extrusion by roots, causing an internal accumulation of  $\text{H}^+$  and an acidification of the cellular pH (Gerendás et al., 1990).

In controlling alkalinity in irrigation water, another factor to consider is the formation of free  $\text{NH}_3$  when  $\text{NH}_4^+$  is incorporated to solutions with alkalinity-associated high pH (Marschner, 1995). An excess of  $\text{NH}_3$  is toxic for some plants (Schenk and Wehrmann, 1979).

The purpose of this study was to determine the effects of  $\text{NH}_4^+$ -N and  $\text{NO}_3^-$ -N on the pH of nutrient solutions and to define at which  $\text{NO}_3^- : \text{NH}_4^+$  ratio  $\text{HCO}_3^-$ -induced alkalinity was counteracted.

## **MATERIALS AND METHODS**

Ornamental sunflower (*Helianthus annuus* L.) 'Big Smile' seeds (Ball Seed Co., Chicago, Ill.) were germinated on 13 Oct. 2000 under room temperature conditions. Once shoots reached a height of 4 to 5 cm, the seedlings were transplanted on 20 Oct. 2000 into 1.6-L plastic containers holding a 25% strength modified Hoagland's nutrient solution for macronutrients and 100% strength for micronutrients (Tables A2, A4, A6, A8, and A10, appendix). The solutions were prepared with  $\text{Ca}(\text{NO}_3)_2 \cdot 4\text{H}_2\text{O}$ ,  $\text{NaNO}_3$ ,  $(\text{NH}_4)_2\text{SO}_4$ ,  $\text{KNO}_3$ ,  $\text{CaSO}_4 \cdot 2\text{H}_2\text{O}$ ,  $\text{KH}_2\text{PO}_4$ ,  $\text{K}_2\text{SO}_4$ ,  $\text{MgSO}_4 \cdot 7\text{H}_2\text{O}$ , Fe-DTPA,  $\text{CuSO}_4 \cdot 5\text{H}_2\text{O}$ ,  $\text{ZnSO}_4 \cdot 5\text{H}_2\text{O}$ ,  $(\text{NH}_4)_6\text{Mo}_7\text{O}_{24} \cdot 4\text{H}_2\text{O}$ ,  $\text{MnSO}_4 \cdot \text{H}_2\text{O}$ , and  $\text{H}_3\text{BO}_3$ . After one week, the macronutrients were increased to 100% strength (Table A3, A5, A7, A9, and A11, appendix).

Plants were grown in a controlled environment chamber (Environmental Growth Chambers, Oh., Model M96-10-5K-0750A-277/480). Temperature was set at  $27^{\circ}/16^{\circ}\text{C}$  daytime/nighttime, and the average relative humidity was 65%. Day length was maintained from 0700 HR to 1900 HR throughout the experiment. During daytime, the average PAR was  $480 \mu\text{mol} \cdot \text{m}^{-2} \cdot \text{s}^{-1}$ .

The containers were covered with a bicolor plastic sheet to prevent light from reaching nutrient solution and roots, and to avoid algal growth. Filtered air was bubbled constantly through nutrient solution in each container through a manifold system connected to a 1PH air pump (Model 2Z866, Dayton Electric MFG Co., Chicago, IL.)

The experiment was a 5 x 2 completely randomized factorial design with five ratios of  $\text{NO}_3^- : \text{NH}_4^+$  and two concentrations of  $\text{NaHCO}_3$ . Five replications were used,



one plant per replication. The  $\text{NO}_3^- : \text{NH}_4^+$  treatments were 1:0 (Annex 3), 0.75:0.25 (Annex 5), 0.5:0.5 (Annex 7), 0.25:0.75 (Annex 9), and 0:1 (Annex 11), all of which had a total of 15 mM N. These  $\text{NH}_4^+ : \text{NO}_3^-$  ratios were replicated at two  $\text{NaHCO}_3$  levels: 0 and 5 mM, yielding a total of 10 treatments. Solutions were prepared with nanopure water, replenished as needed and changed every week for two weeks. Treatments started on 3 Nov. 2000.

Data were analyzed with ANOVA (SAS Institute, Inc., N.C.) and LSD multiple comparison tests. The parameters measured were: solution pH on a daily basis, total and root dry mass, shoot:root ratio, leaf number, and shoot elongation on a weekly basis. A 1-ml sample was drawn from each container and pH measured with a TwinpH<sup>®</sup> meter (Spectrum Technologies, Inc., Plainfield, Ill.). Dry mass was obtained as indicated in experiments of Chapters I to III.

## RESULTS

### Solution pH

During the first 14 days without  $\text{NaHCO}_3$ , the 1  $\text{NO}_3^- : 0 \text{NH}_4^+$  treatment caused the pH to increase from the initial 6.3 to 7.05 (Fig. 5.1A). This represents the alkalizing effect of  $\text{NO}_3^-$ . This effect of  $\text{NO}_3^-$  continued to increase solution pH to 7.77 at day 30. When 5 mM  $\text{NaHCO}_3$  was added at day 15, the new initial pH, 8.01, increased to 8.25 at day 30. This represents the alkalizing effect of  $\text{NO}_3^-$  plus  $\text{HCO}_3^-$ . The results imply that the use of  $\text{NO}_3^-$  enhances the alkalinity effect of  $\text{HCO}_3^-$ .

In the 0.75  $\text{NO}_3^- : 0.25 \text{NH}_4^+$  treatment, solution pH decreased from the initial 6.3 to 4.18 during the first 14 days without  $\text{NaHCO}_3$  (Fig. 5.1B). The pH decrease was due to the acidifying effect of  $\text{NH}_4^+$ . The acidifying effect of  $\text{NH}_4^+$  continued decreasing solution pH to 3.53 at day 30. After the addition of 5 mM  $\text{NaHCO}_3$  at day 15, the new

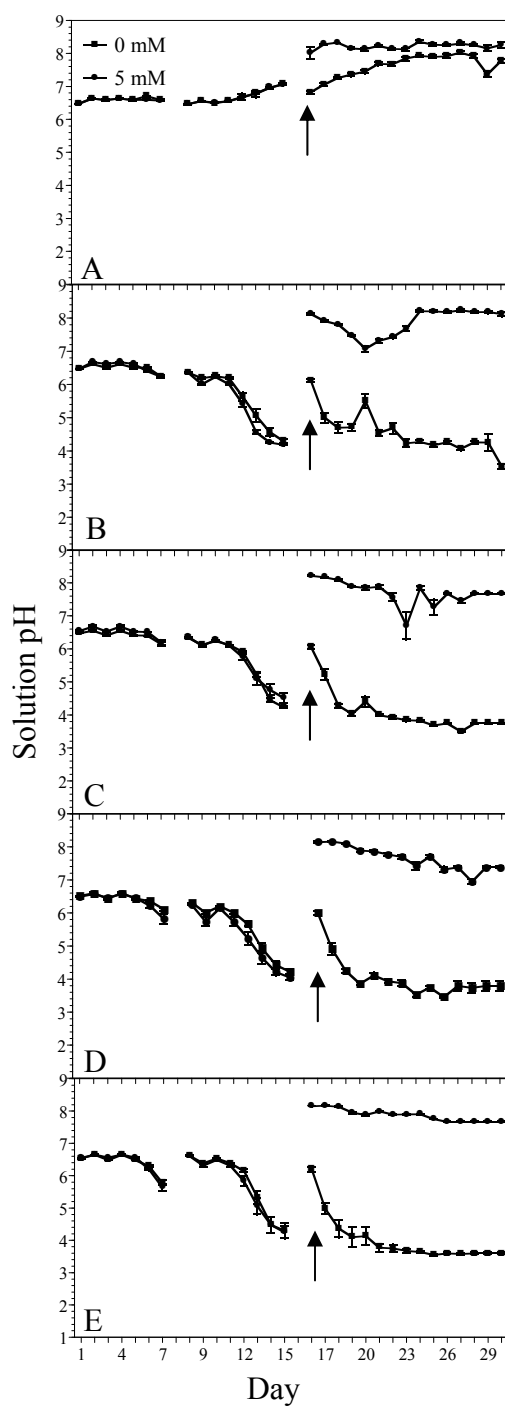

Fig. 5.1. Solution pH in *Helianthus annuus* 'Big Smile' plants grown in hydroponics with 0 and 5 mM of NaHCO<sub>3</sub> and varying NO<sub>3</sub><sup>-</sup> : NH<sub>4</sub><sup>+</sup> ratios: 1:0 (A), 0.75:0.25 (B), 0.5:0.5 (C), 0.25:0.75 (D), and 0:1 (E). Bars represent standard error of the mean. Arrows show beginning of NaHCO<sub>3</sub> treatments.

pH, 8.12, was unaffected by day 30. The pH increase represents the alkalizing effect of  $\text{NO}_3^-$  plus  $\text{HCO}_3^-$ , while no further increase was due to the acidification effect of the 25%  $\text{NH}_4^+$ -N used. Nonetheless, using 25%  $\text{NH}_4^+$ -N in the nutrient solution did not reduce alkalinity significantly.

During the first 14 days without  $\text{NaHCO}_3$ , the 0.5  $\text{NO}_3^-$  : 0.5  $\text{NH}_4^+$  treatment caused solution pH to decrease from 6.3 to 4.42 (Fig. 5.1C), representing the acidifying effect of  $\text{NH}_4^+$ . The acidifying effect of  $\text{NH}_4^+$  continued decreasing solution pH to 4.06 at day 30. When 5 mM  $\text{NaHCO}_3$  was added at day 15, nutrient solution pH increased to 8.21. This new pH was decreased to 7.44 by day 30. The increase was caused by the alkalizing effect of  $\text{NO}_3^-$  plus  $\text{HCO}_3^-$ , while the decrease represented the acidifying effect of  $\text{NH}_4^+$ .

In the 0.25  $\text{NO}_3^-$  : 0.75  $\text{NH}_4^+$  and 0  $\text{NO}_3^-$  : 1  $\text{NH}_4^+$  treatments, the results showed a tendency similar to that of the 0.5  $\text{NO}_3^-$  : 0.5  $\text{NH}_4^+$  ratio. At day 14, solution pH decreased from the initial 6.3 to 4.05 and 4.25, respectively (Fig. 5.1D-E). The acidifying reaction of  $\text{NH}_4^+$  continued decreasing pH to 3.73 and 3.58, respectively, at day 30. When  $\text{NaHCO}_3$  was added, the new solution pH, 8.14 and 8.15, was decreased to 7.38 and 7.67, respectively, at day 30.

The results are summarized in Fig 5.2. Final solution pH decreased as the proportion of  $\text{NH}_4^+$  increased irrespective of the  $\text{NO}_3^-$  :  $\text{NH}_4^+$  treatment. The decrease in pH was greatest in solutions containing no  $\text{NaHCO}_3$ , but solutions prepared with 5 mM  $\text{NaHCO}_3$  exhibited a slight but significant decrease from around 8.15 to 7.40, especially when the proportion of  $\text{NH}_4^+$ -N was 50% and above.

### **Shoot Height and Number of Leaves**

Shoot growth was significantly affected by high concentrations of  $\text{NaHCO}_3$  (Fig. 5.3). Shoot height and number of leaves were unaffected by the  $\text{NaHCO}_3$ -induced alkalinity in the 1  $\text{NO}_3^-$  : 0  $\text{NH}_4^+$  treatment (Fig. 5.4A, and 5.5A). In the 0.75  $\text{NO}_3^-$  : 0.25 $\text{NH}_4^+$  treatment, plants grown with 5 mM  $\text{NaHCO}_3$  were taller and had more leaves compared to plants with no  $\text{NaHCO}_3$  (Fig. 5.4B, and 5.5B). For the remaining  $\text{NO}_3^-$  : $\text{NH}_4^+$  treatments, shoot height and number of leaves decreased as  $\text{NH}_4^+$ -N proportion

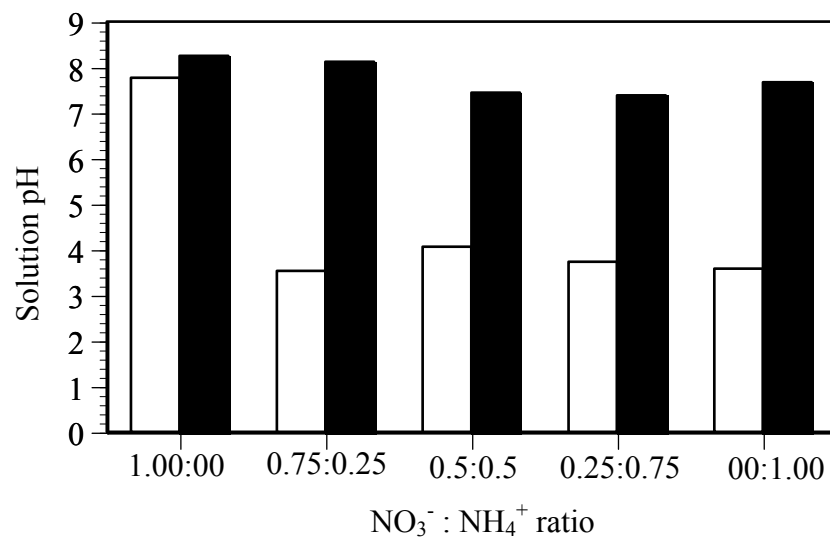

Fig. 5.2. Solution pH at day 30 of *Helianthus annuus* 'Big Smile' plants grown in hydroponics with 0 mM (open bars) and 5 mM (solid bars) NaHCO<sub>3</sub> and varying NO<sub>3</sub><sup>-</sup> : NH<sub>4</sub><sup>+</sup> ratios.



Fig. 5.3. Effect of the concentration of NaHCO<sub>3</sub> and varying NO<sub>3</sub><sup>-</sup>:NH<sub>4</sub><sup>+</sup> ratios on the growth and general appearance of shoots of *Helianthus annuus* 'Big Smile' plants at harvest time.

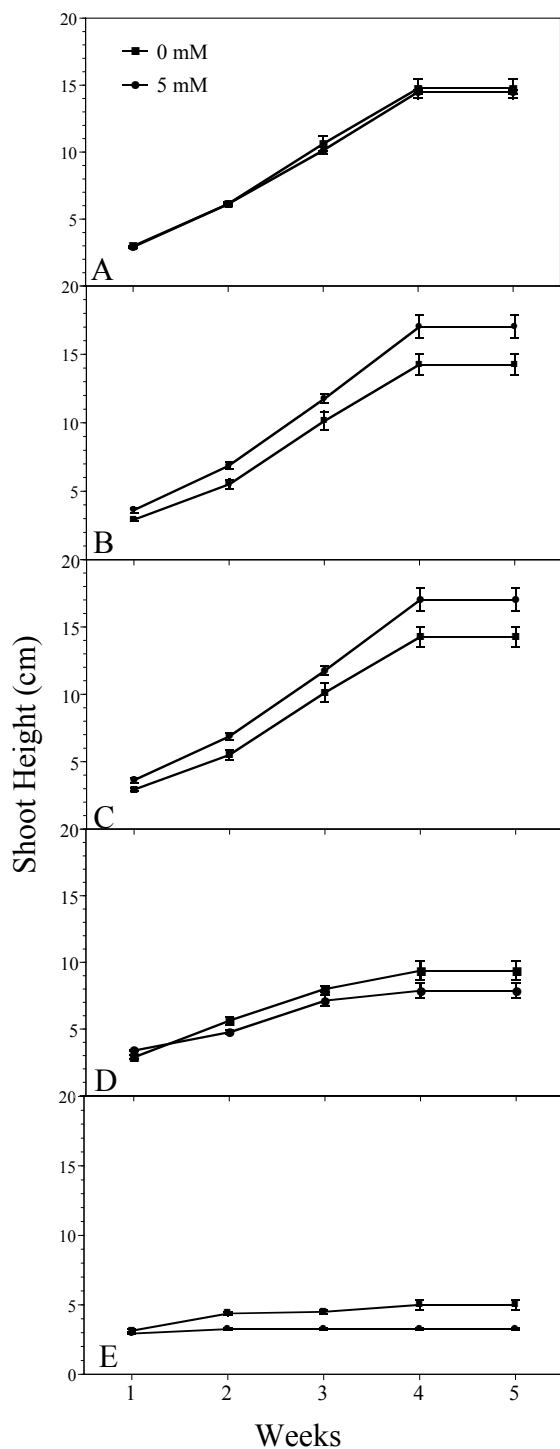

Fig. 5.4. Shoot height (cm) of *Helianthus annuus* 'Big Smile' plants grown in hydroponics with 0 and 5 mM of NaHCO<sub>3</sub> and varying NO<sub>3</sub><sup>-</sup> : NH<sub>4</sub><sup>+</sup> ratios: 1:0 (A), 0.75:0.25 (B), 0.5:0.5 (C), 0.25:0.75 (D), and 0:1 (E). Bars represent standard error for the mean (n=5).

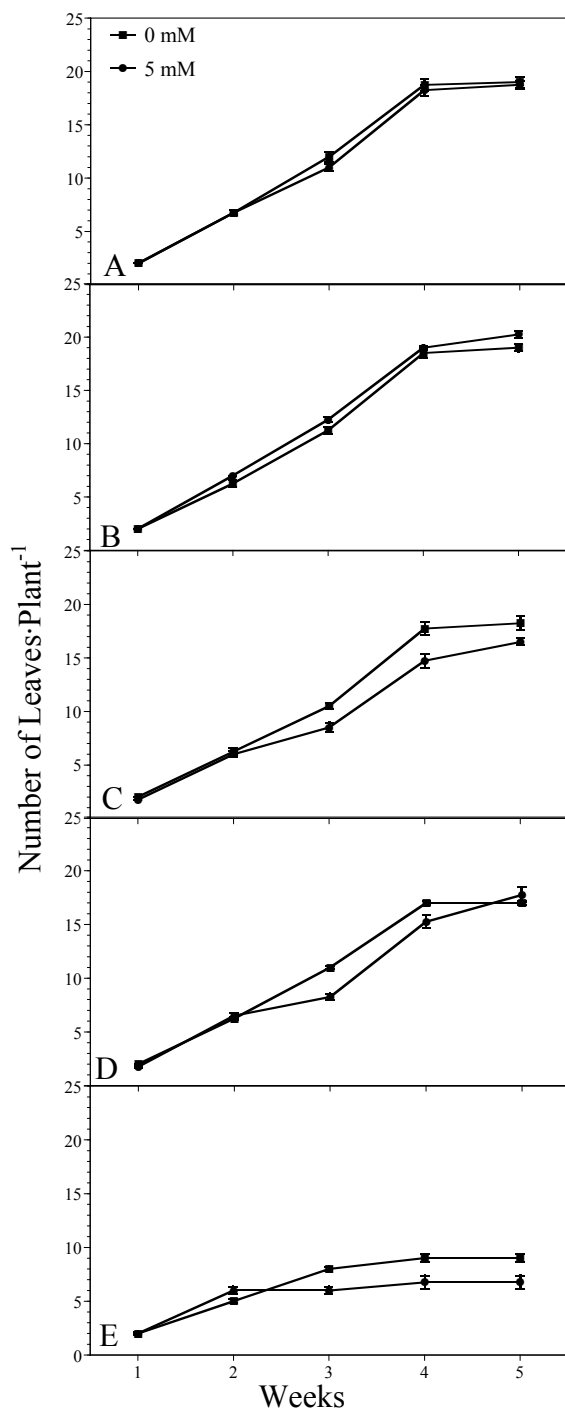

Fig. 5.5. Number of leaves per plant of *Helianthus annuus* 'Big Smile' plants grown in hydroponics with 0 and 5 mM  $\text{NaHCO}_3$  and varying  $\text{NO}_3^- : \text{NH}_4^+$  ratios: 1:0 (A), 0.75:0.25 (B), 0.5:0.5 (C), 0.25:0.75 (D), and 0:1 (E). Bars represent standard error for the mean (n=5).

increased (Fig. 5.4C-E, and 5.5C-E) and there was no difference between levels of  $\text{NaHCO}_3$ .

The decrease in shoot growth and number of leaves was associated with the addition of  $\text{NaHCO}_3$  to solutions containing a high proportion of  $\text{NH}_4^+$ -N. The plants showed severe toxicity symptoms within 24 h after the addition of  $\text{NaHCO}_3$ . Symptoms observed included severe wilting and interveinal yellowing of leaves starting at the leaf tip. Some plants showed a slight recovery but they were not able to recuperate the maximum growth rate.

### **Total and Root Dry Mass**

Total and root dry mass were affected by the  $\text{NO}_3^- : \text{NH}_4^+$  treatment (Fig. 5.6). In plants treated with no  $\text{NaHCO}_3$ , an increase in the proportion of  $\text{NH}_4^+$ -N resulted in a decrease in dry mass. Ammonium at 75% to 100% of total N, caused a decrease between 75% and 98% in dry matter, respectively. The addition of  $\text{NaHCO}_3$  did not modify the response to the  $\text{NO}_3^- : \text{NH}_4^+$  ratio, except for plants grown in a 0.75:0.25 ratio, since they accumulated a significantly higher ( $P \leq 0.05$ ) dry matter compared to plants treated with no  $\text{NaHCO}_3$ .

### **Shoot:Root Ratio**

The shoot:root ratio in plants growing in solution containing no  $\text{NaHCO}_3$  increased as the  $\text{NH}_4^+$ -N proportion increased from 0 to 0.75, but it was severely affected in solutions with 100%  $\text{NH}_4^+$ -N (Fig. 5.6). A concentration of 5 mM  $\text{NaHCO}_3$  caused similar results but the increment was not as pronounced as it was for the control plants.

## **DISCUSSION**

### **Effect of the $\text{NO}_3^- : \text{NH}_4^+$ Ratio**

Solution pH was greatly affected by the  $\text{NO}_3^- : \text{NH}_4^+$  ratio. In general, in exclusively  $\text{NO}_3^-$ -N fed sunflower plants, solution pH increased over time (Fig. 5.1A) while in  $\text{NH}_4^+$ -N fed plants there was rapid acidification, even at the lowest proportion of  $\text{NH}_4^+$  evaluated (Fig. 5.1B-E).



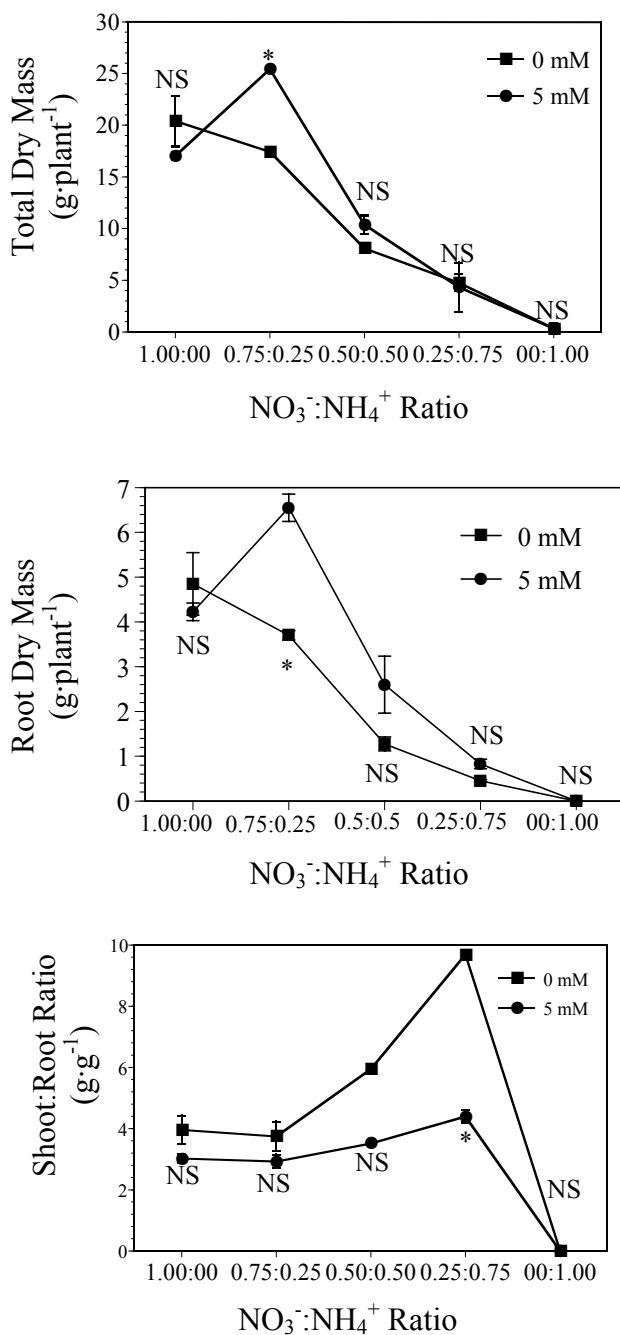

Fig. 5.6. Total dry mass (g), root dry mass (g), and shoot:root ratio ( $\text{g}\cdot\text{g}^{-1}$ ) at final harvest of *Helianthus annuus* 'Big Smile' plants grown in hydroponics with 0 and 5 mM  $\text{NaHCO}_3$  and varying  $\text{NO}_3^-:\text{NH}_4^+$  ratios. Bars represent standard error of the mean (n=5). \*, NS, significant at  $P \leq 0.05$  and non-significant, respectively.

Sunflower plants grown in nutrient solutions containing no  $\text{NaHCO}_3$  and a 1  $\text{NO}_3^-$  : 0  $\text{NH}_4^+$  ratio were not able to alter initial pH of 6.3 during the first week. When the shoots started to elongate, a rapid increase in pH was observed, reaching a pH of 7.0 at the end of the second week (Fig. 5.1A and 5.3A). Alkalinization of the solution continued from day 15 to 30.

In solutions containing 25% to 100%  $\text{NH}_4^+$ -N, there was a slight acidification at day 7 and a more marked decrease in pH at day 15, when pH reached levels of 4.05 to 4.51 (Fig. 5.1B-E). From day 15 to 30, the acidification of the nutrient solution continued.

Similar results have been published for a number of plants species. Douglas fir plants grown in solution containing only  $\text{NO}_3^-$ -N increased pH while those grown in solutions containing just  $\text{NH}_4^+$ -N decreased pH (Kamminga-van Wijk and Prins, 1993). *Ageratum* decreased solution pH from 7.74 in exclusively  $\text{NO}_3^-$ -N fed plants to 3.08 in  $\text{NH}_4^+$ -N fed plants, whereas in *salvia* the pH decreased from 6.92 to 3.11 (Jeong and Lee, 1996).

Ammonium and  $\text{NO}_3^-$ -N comprise about 80% of the total ion uptake by plants (Marschner, 1995), so the predominant source of N taken up by plants has a profound effect on soil or nutrient solution pH. It is well documented that nutrition with exclusively  $\text{NO}_3^-$ -N causes a significant increase in medium pH because its uptake is coupled to the consumption of  $\text{H}^+$ , through a  $\text{H}^+/\text{NO}_3^-$  co-transport (Mengel and Kirkby, 2001). Uptake of  $\text{H}^+$  from the solution causes an increase in medium pH. On the other hand, uptake of  $\text{NH}_4^+$  is correlated to an equimolar extrusion of  $\text{H}^+$  and acidification of the medium (Marschner, 1995).

Acidification and alkalinization by  $\text{NH}_4^+$  and  $\text{NO}_3^-$  uptake, respectively, were corroborated in this experiment since increasing proportions of  $\text{NH}_4^+$ -N induced an acidification of the nutrient solution at the end of the second week, while solution pH increased in plants fed exclusively with  $\text{NO}_3^-$ -N.

A high proportion of  $\text{NH}_4^+$  in the solution, 50% and above, resulted in decreased plant growth, as indicated by the decrease in Total and root mass (Fig. 5.6). Decreased

dry matter of melon (Ben-Oliel and Kafkati, 2002), wheat (Abdellaoui and Talouizte, 2001), and sunflower (Lasa et al., 2001) plants fed exclusively with  $\text{NH}_4^+$ -N have also been reported.

The decrease in growth caused by high  $\text{NH}_4^+$  is thought to be caused by the acidification of the solution in  $\text{NH}_4^+$ -N fed plants. The acidification eventually affects the capacity of  $\text{H}^+$  extrusion and reduces the uptake of nutrients once pH is very low (Gerendás et al., 1990). This might be due to a decrease in the membrane potential that leads to a breakdown in the  $\text{H}^+/\text{NO}_3^-$  co-transport, or to an inhibition in the synthesis of the  $\text{NO}_3^-$  carriers or  $\text{NO}_3^-$  reductase by  $\text{NH}_4^+$  (Kamminga-van Wijk and Prins, 1993). Once the acquisition of  $\text{NH}_4^+$  and extrusion of  $\text{H}^+$  is impaired,  $\text{H}^+$  accumulates in root cells, and in order to keep constant internal pH, malate is decarboxylated, giving rise to depletion of the malate pool (Yan et al., 1992). Depletion of malate causes additional decreases in plant growth (Marschner, 1995).

The decrease in dry matter was between 65% and 75% with 50%  $\text{NH}_4^+$ -N and up to 98% in plants fed with 100%  $\text{NH}_4^+$ -N (Fig. 5.6). Despite this severe loss of dry mass, solution pH was acidified at approximately the same rate compared to the rate in plants growing in solution with 25%  $\text{NH}_4^+$ -N (Fig. 5.1C-E). It is obvious that the plants were not playing an important role since growth was markedly impaired, implying that other processes were responsible of this acidification. In soils, microbes can oxidize  $\text{NH}_4^+$  to  $\text{NO}_3^-$  through nitrification, which causes acidification (Havlin et al., 1999). It is possible that bacterial populations in the nutrient solution were nitrifying the excessively high proportion of  $\text{NH}_4^+$ , causing acidification.

Another possible reason for the acidification observed could be the volatilization of the  $\text{NH}_3$  produced through the reaction  $\text{NH}_4^+ \longrightarrow \text{NH}_3 + \text{H}^+$  (Havlin et al., 1999). However, this is unlikely since the  $\text{pK}_a$  of the reaction is 9.3 (Lindsey, 1979), while initial pH of the solutions evaluated was 6.3.

In solutions containing no  $\text{NaHCO}_3$ , growth of sunflower plants was higher when the  $\text{NO}_3^- : \text{NH}_4^+$  ratio was 1:0 and 0.75:0.25, but in the first situation, plants surpassed the Total mass of the plants grown in the latter by 21%. This is in agreement with

reports indicating that the  $\text{NH}_4^+$ -N proportion should be around 25% of total N, although some species can tolerate up to 100% (Jeong and Lee, 1992). According to these results, a proportion higher than 25% should be avoided for growing sunflower plants.

### **The Interaction of $\text{NaHCO}_3$ and $\text{NO}_3^- : \text{NH}_4^+$ Ratio**

Solution pH was greatly increased by the addition of  $\text{NaHCO}_3$  to the nutrient solutions. The pH increased to 8.14 and 8.25, depending on the  $\text{NO}_3^- : \text{NH}_4^+$  ratio (Fig. 5.1). In exclusively  $\text{NO}_3^-$ -N fed sunflower plants the pH remained virtually unaffected after the addition of  $\text{NaHCO}_3$  (Fig. 5.1A). In plants treated with a  $\text{NH}_4^+$  proportion higher than 50%, there was a counteraction of the  $\text{HCO}_3^-$ -induced alkalinity (Fig. 5.1C-E).

In general, sunflower plants exhibited the highest growth under  $\text{NaHCO}_3$ -induced alkalinity when the  $\text{NO}_3^- : \text{NH}_4^+$  ratio was 1:0 and 0.75:0.25 (Fig. 5.3 and 5.6A and B), but in the latter Total mass was 40% higher than in the first treatment. Proportions of  $\text{NH}_4^+$ -N higher than 50% resulted in stunted growth or plant death.

Plants fed with 100%  $\text{NO}_3^-$ -N grew well and did not exhibit Fe deficiency symptoms even though nutrient solution pH was above 8.0 (Fig. 5.1A and 5.3). This is probably explained by the chelated form of Fe used. The form of Fe used was DTPA, which is a stable chelated Fe at pH of up to 8.0 (Reed, 1996b).

Plants grown in a 0.75  $\text{NO}_3^- : 0.25 \text{NH}_4^+$  ratio and in solutions containing  $\text{NaHCO}_3$ , were able to decrease solution pH from the initial 8.12 to 7.07 at day 5, indicating that the plants neutralized partially the alkalinity associated to the incorporation of  $\text{NaHCO}_3$  (Fig. 5.1B). After this point, the acidification ability was lost and pH gradually increased back to 8.12. Despite the high level of  $\text{NaHCO}_3$ , plants exhibited the best growth, which even surpassed that obtained in solutions containing no  $\text{NaHCO}_3$  at any  $\text{NO}_3^- : \text{NH}_4^+$  ratio.

Schenk and Wehrmann (1979) estimated the concentration of  $\text{NH}_3$  produced in nutrient solutions with varying pH by using a modified Henderson-Hasselbach equation. Using similar approach, our calculation estimated that the potential concentration of free  $\text{NH}_3$  right after the addition of the  $\text{NaHCO}_3$  was 0.278 mM at a 0.75  $\text{NO}_3^- : 0.25 \text{NH}_4^+$

ratio. This level of  $\text{NH}_3$  might be considered high enough to induce toxicity, but sunflower plants did not show symptoms of toxicity at this ratio. At a 0.75  $\text{NO}_3^-$  : 0.25  $\text{NH}_4^+$  ratio, only 5.56% of the  $\text{NH}_4^+$  was converted to  $\text{NH}_3$ . The remaining 94.44% was available for plant uptake.

The capacity to decrease solution pH by day 5 in plants treated with a 0.75  $\text{NO}_3^-$  : 0.25  $\text{NH}_4^+$  ratio indicated that the plants were removing more  $\text{NH}_4^+$ -N than  $\text{NO}_3^-$ -N. Since the uptake of  $\text{NH}_4^+$ -N occurs more rapidly than that for  $\text{NO}_3^-$ -N (Kammenga-van Wijk and Prins, 1993), it is possible that during the first five days of treatment with  $\text{NaHCO}_3$  plants took up a higher proportion of N in  $\text{NH}_4^+$  form, causing a decrease in solution pH. This lower pH might have resulted in more soluble Fe and increased Fe content in plant tissues (Flores et al., 2001) due to activation of the Fe-reductase (Eckhardt and Buckhout, 2000; Marschner et al., 1986; Moog and Bruggemann, 1995; Römheld and Marschner, 1983).

Some reports indicate that  $\text{NH}_4^+$  uptake is enhanced at alkaline pH, such as that induced by  $\text{NaHCO}_3$ , (Vaast et al., 1998; Vasey et al., 1990). This could have caused the significant decrease in solution pH, about 1.1 units, observed by day 5. Once the  $\text{NH}_4^+$ -N was depleted, plants started to take up an increasing proportion of N in  $\text{NO}_3^-$  form, which would explain the increase in solution pH after day 5 of treatment with  $\text{NaHCO}_3$  (Fig. 5.1B). These results suggest that small amounts of  $\text{NH}_4^+$  are favorable under alkalinity, but the positive effect lasts for only few days. In order to sustain the beneficial effect of  $\text{NH}_4^+$  supplementary additions of  $\text{NH}_4^+$  on a weekly basis might allow improved plant growth.

Increasing proportions of  $\text{NH}_4^+$ -N under  $\text{NaHCO}_3$ -induced alkalinity may have increased  $\text{NH}_3$  toxicity. Using the modified Henderson-Hasselbach equation, as reported by Schenk and Wehrmann (1979), the potential concentration of  $\text{NH}_3$  in solutions containing 50%, 75%, and 100% of  $\text{NH}_4^+$ -N were calculated to be 0.684, 0.873 and 1.192 mM, respectively. These levels of  $\text{NH}_3$  could explain the severe decrease in growth of sunflower plants and the death of plants cultivated under a 0  $\text{NO}_3^-$ : 1  $\text{NH}_4^+$  ratio.

## CONCLUSIONS

Plant growth was greater in solutions with no alkalinity and levels of  $\text{NH}_4^+$  between 0% and 25%, but higher proportions caused  $\text{NH}_4^+$  toxicity and stunted growth. In solutions with a high  $\text{NaHCO}_3$ -induced alkalinity, the highest growth was exhibited by plants cultivated in a 0.75  $\text{NO}_3^-$ : 0.25  $\text{NH}_4^+$  ratio. Higher proportions of  $\text{NH}_4^+$  resulted in poorer growth and plant death due to  $\text{NH}_3$  toxicity.

## CHAPTER VI

### **EFFECT OF COUNTER-CATIONS OF BICARBONATE ON BEAN (*Phaseolus vulgaris* L.) 'Poncho' GROWN IN HYDROPONICS**

#### **INTRODUCTION**

Nutrition studies on individual nutrients have a major constraint. The constraint is that most nutrients are applied in ionic form. In order to maintain the balance of charges the equivalent sum of cations must be equal to the equivalent sum of anions (Scheverns and Cornell, 1993). This fact makes the use of experimental designs, such as factorials, very complicated, since the use of a given anion, implies the use of a counter-cation. In addition to that, the additive, synergistic, or antagonistic interaction between ions may lead to conclusions that are not supported by real facts.

Research on  $\text{HCO}_3^-$  has been performed by using predominantly  $\text{NaHCO}_3$  (Alcántara et al., 1988; Alhendawi et al., 1997; Campbell and Nishio, 2000; de la Guardia and Alcántara, 2002; Dofing et al., 1989; Kuehny and Morales, 1998; Kramer and Peterson, 1990; Nickolic and Römheld, 2002; Nickolic and Kastori, 2000; Pearce et al., 1999a and 1999b; Peiter et al., 2001; Romera et al., 1997; and Romera et al., 1992), and, to a lesser extent,  $\text{KHCO}_3$  (Bialczyk and Lechowski, 1995; Bialczyk et al., 1994; and Kosegarten et al., 1999). In some of these studies it is not possible to distinguish between the effect of  $\text{Na}^+$  or  $\text{K}^+$  from the effect of  $\text{HCO}_3^-$ . Sodium is detrimental in natriophobic plant species (Marschner, 1995), while  $\text{K}^+$  is a nutrient that could interfere with the negative effect of  $\text{HCO}_3^-$ .

A mixture experiment is one where two or more components are mixed or blended in varying proportions to form a treatment, and all the treatments have the same volume or concentration (Cornell, 2002). A component is each ingredient present in the mixture. If each component in the mixture is expressed as fraction, then the sum of all the components must be equal to one. The response to the mixture depends only on the relative proportions of the components and the response is not due to the volume or

concentration of the mixture (Cornell and Linda, 1991). If all the treatments are repeated at different volumes or concentrations, this is called a mixture-amount experiment.

The number of components determines the dimension of the response surface. If there are two components, then the response surface is one-dimensional, and the representation is a line (Cornell and Linda, 1991). If the number of components is three, then the response surface is bi-dimensional, and it can be represented as an equilateral triangle (Cornell and Linda, 1991) as shown in Fig. 6.1. In an equilateral triangle, the vertices (V) represent the points in which there is only one component in the mixture, also known as pure blends. The points along the sides (B) of the triangle are the binary blends, and contain two components in each mixture. The points in the interior (T) of the triangle contain all three components, also known as tertiary blends. The centroid point (C) contains the three components in the same proportion. The line that departs from the middle point of the binary blends and ends at any vertex is known as the coordinate line for the respective component. Coordinates show the effect of increasing proportions of one component in the mixture.

Figure 6.2 gives an example of the design points of a non-constrained mixture experiment augmented with three interior points, or tertiary blends, and the proportions of each component in each mixture. The proportion of components X, Y, and Z is indicated.

Mixture and mixture-amount experiments help to make predictions of the response to any mixture and to measure the influence of each component on the response (Cornell and Harrison, 1997). Mixture experiments are useful when the objective is to find a zone or group of optimal conditions, rather than finding a single point or mixture (Schrevers and Cornell, 1993). By doing so, the probability that other properties are also optimized within this zone is higher.



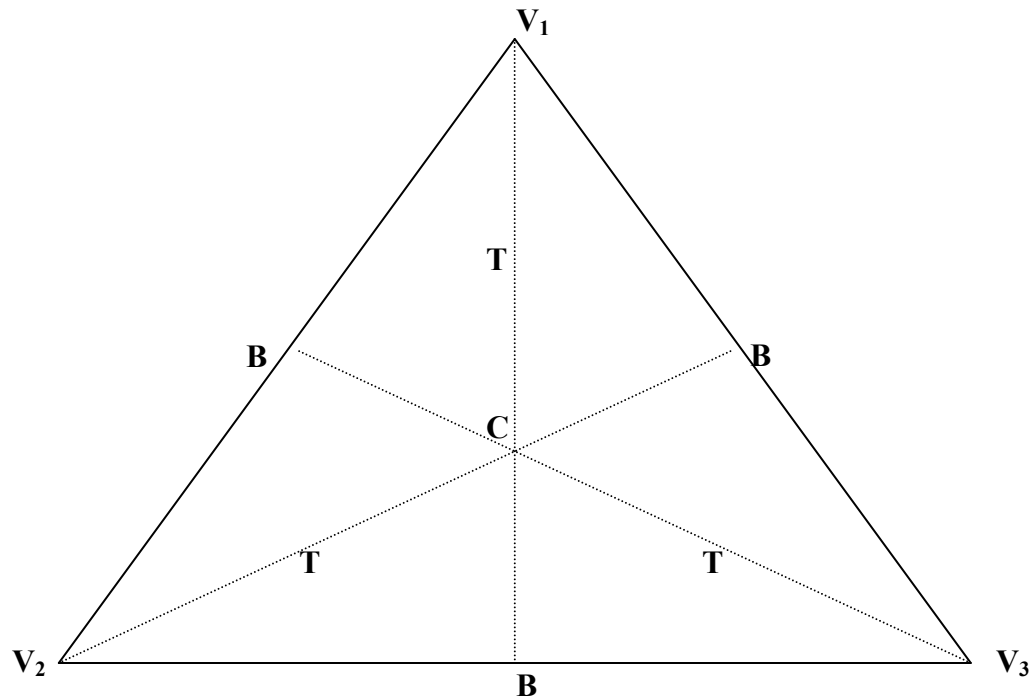

V= vertex or pure blend  
 B= binary blends or two component mixtures  
 T= tertiary blends or interior points  
 C= centroid

Fig. 6.1 Simplex centroid mixture design augmented with three interior points. Dotted lines are the coordinates for the components  $V_1$ ,  $V_2$ , and  $V_3$ .

Mixture theory allows the estimation of models to make the predictions one may be interested in. The models may have different levels of complexity. A linear model allows only for the effects of the pure blends, and the estimation is done by the use of coefficients that estimate the effect of each blend. Thus, a linear model would have the following form:

$$R = \beta_1 X + \beta_2 Y + \beta_3 Z$$

Where  $R$  is the response,  $X$ ,  $Y$ , and  $Z$  are the pure blends, and  $\beta_1$ ,  $\beta_2$ , and  $\beta_3$  are the coefficient estimates. A higher order model allows for the effect of interactions between the components, each interaction will have a coefficient estimate. A quadratic and special cubic model would have the following elements:

$$R = \beta_1 X + \beta_2 Y + \beta_3 Z + \beta_4 XY + \beta_5 XZ + \beta_6 YZ$$

$$R = \beta_1 X + \beta_2 Y + \beta_3 Z + \beta_4 XY + \beta_5 XZ + \beta_6 YZ + \beta_7 XYZ.$$

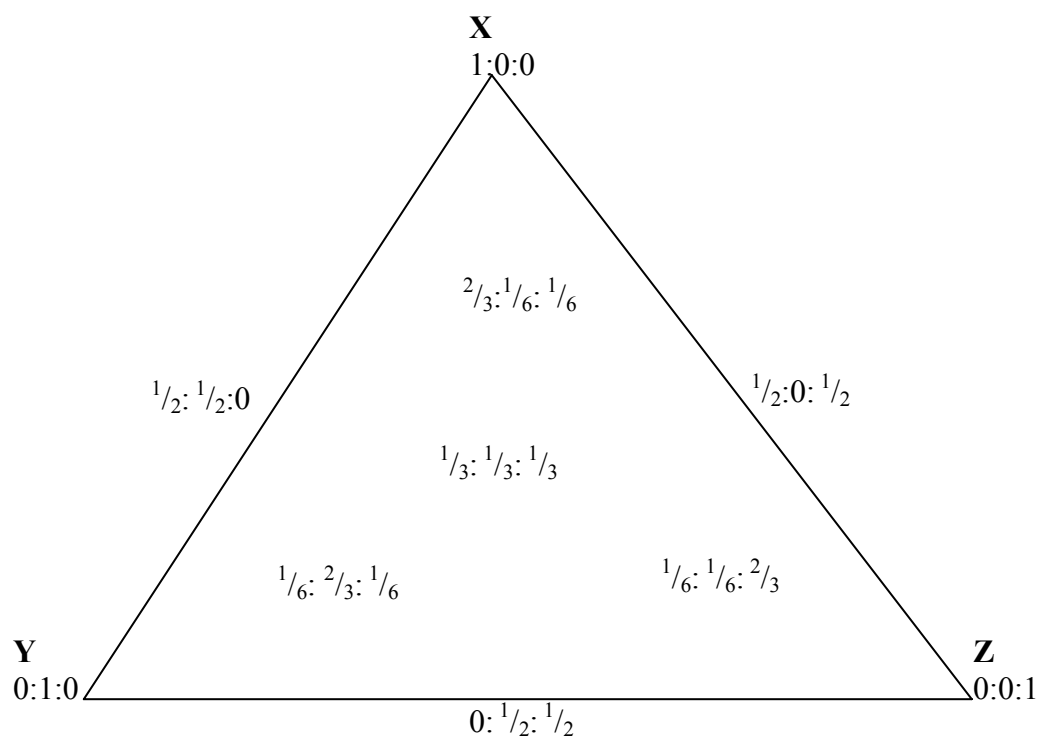

Fig. 6.2. Example of a mixture experiment with the proportions of a hypothetical experiment with X, Y, and Z components.

Some software programs, such as Design Expert<sup>®</sup> (Stat-Ease, Inc. Mn), allow estimating the mixture at which the maximum, optimum, and minimum response is obtained. Thus, the more and least desirable mixtures are determined. This is known as optimization.

The main purpose of this study was to determine the effect of the counter-cation of  $\text{HCO}_3^-$  in the response of plants to alkalinity. Since the negative charge of  $\text{HCO}_3^-$  can be neutralized by various cations, a mixture experiment is ideally suited to delineate the counter-cation effect. Mixture experiments will permit the estimation of the separate effect of the counter-cations as well as the interaction of two or three of them in varying proportions. In a series of mixture experiments, the counter-cations  $\text{Na}^+$ ,  $\text{K}^+$ ,  $\text{NH}_4^+$ ,  $\text{Cs}^+$ , and  $\text{Rb}^+$  were evaluated. For these experiments a fast growing plant was desired, hence bean was chosen as the model plant. Plants were grown in hydroponics to determine the

direct and immediate effect of the mixture of counter-cations. The experiments were conducted in an environment-controlled growth chamber to standardize growing conditions.

## **MATERIALS AND METHODS**

### **Experiment 6.1. Effect of Mixtures of Na<sup>+</sup>, K<sup>+</sup>, and NH<sub>4</sub><sup>+</sup> on the Response of Bean Plants to HCO<sub>3</sub><sup>-</sup>**

The experimental design was a mixture experiment with three components: Na<sup>+</sup>, K<sup>+</sup>, and NH<sub>4</sub><sup>+</sup>. The objective was to determine if the counter-cations have an effect on the response of bean plants to HCO<sub>3</sub><sup>-</sup>.

Pinto bean (*Phaseolus vulgaris* L.) 'Poncho' (local seed) seeds were germinated under room temperature conditions on 17 July 2001. Seedlings were transferred to 1.9-L plastic containers, one plant per container, on 24 July. Plants were grown in a controlled environment chamber under similar conditions as described for sunflower in Chapter V. The containers and air bubbles were handled in the same way as well. Plants were established for one week in a 25% strength modified Hoagland's nutrient solution (Table A12, appendix).

Adding HCO<sub>3</sub><sup>-</sup> to nutrient solutions causes precipitation of phosphates. To avoid P precipitation, the NaHCO<sub>3</sub>, KHCO<sub>3</sub>, and NH<sub>4</sub>HCO<sub>3</sub> mixtures were added to a P- and K-free nutrient solution (Table A13, appendix). Potassium was not added to the nutrient solution because it was part of the mixtures. The plants were exposed to treatment solutions for six days. To maintain a constant level of N nutrition, enough NO<sub>3</sub><sup>-</sup>-N was added to each mixture to keep a concentration of 10 mM total N in each treatment.

To supply all treatments with adequate P, the solutions were changed and the plants exposed to a P- and K-containing solution for one day. The solution was composed of 0.5 mM P, prepared with equal molar concentration for NH<sub>4</sub><sup>+</sup>, K<sup>+</sup>, and Na<sup>+</sup>, using NH<sub>4</sub>H<sub>2</sub>PO<sub>4</sub>, KH<sub>2</sub>PO<sub>4</sub> and NaH<sub>2</sub>PO<sub>4</sub>. Potassium was included at a concentration of 0.17 mM to prevent K<sup>+</sup> deficiency in those mixture treatments that contained no K<sup>+</sup>. The 6 day/1 day cycle was repeated weekly for the duration of the experiment.

A simplex-centroid design augmented with three interior points was selected (Fig. 6.3). Since in preliminary experiments 5 mM  $\text{HCO}_3^-$  caused significant growth reduction and chlorosis, all the mixtures evaluated in present experiment contained 5 mM  $\text{HCO}_3^-$ . The  $\text{Na}^+:\text{K}^+:\text{NH}_4^+$  total mixture was 5 mM, as indicated in Table 6.1 and A13 (appendix). The average pH and EC were 7.77 and 2.21  $\text{dS}\cdot\text{m}^{-1}$ , respectively. All the solutions contained 3.6 mM Ca, 1.6 mM Mg, 2.5  $\text{mg}\cdot\text{L}^{-1}$  Fe, 0.01  $\text{mg}\cdot\text{L}^{-1}$  Cu, 0.03  $\text{mg}\cdot\text{L}^{-1}$  Zn, 0.19  $\text{mg}\cdot\text{L}^{-1}$  Mo, 0.25  $\text{mg}\cdot\text{L}^{-1}$  B, and 0.25  $\text{mg}\cdot\text{L}^{-1}$  Mn (Table A13, appendix).

Experimental units were distributed in the growth chamber in a completely randomized design with 4 replications of one plant per container. The plants were harvested on 21 Aug. 2001 and the parameters measured were: leaf area, fresh and dry leaf mass, fresh and dry root mass, shoot fresh and dry mass, shoot:root ratio, solution pH at harvest time, leaf number, and total chlorophyll content of young leaves. Total chlorophyll was determined according to Moran (1982). Data were analyzed with the Design Expert© version 6.0.4 (Stat-Ease, Inc. Mn) computer program to obtain the tri-dimensional response surface to the mixtures, counter plots and analysis of variance. The best model for each parameter was selected by choosing the one with the highest  $R^2$ , an adequate precision greater than 4.0, and a non-significant lack of fit. Protected Fisher's LSD test was used for multiple comparisons of means, and was obtained with SAS (SAS Institute, Inc., N.C.).

### **Experiment 6.2. Effect of Mixtures of $\text{Na}^+$ , $\text{K}^+$ , and $\text{Cs}^+$ on the Response of Bean Plants to $\text{HCO}_3^-$**

The experimental design was a mixture-amount experiment with three components replicated at two concentrations of  $\text{HCO}_3^-$  (Fig. 6.4). This experiment was executed with the same methodology indicated for Experiment 6.1, but  $\text{NH}_4^+$  was replaced by  $\text{Cs}^+$  as one of the counter-cations to avoid the response of bean plants to the varying  $\text{NO}_3^-:\text{NH}_4^+$  ratios and  $\text{NH}_4^+$  toxicity. Pinto bean (*Phaseolus vulgaris* L.) 'Poncho' (local seed) seeds were germinated under room temperature conditions on 27 Oct. 2001. Seedlings were transferred to 1.9-L plastic containers, one per container, on

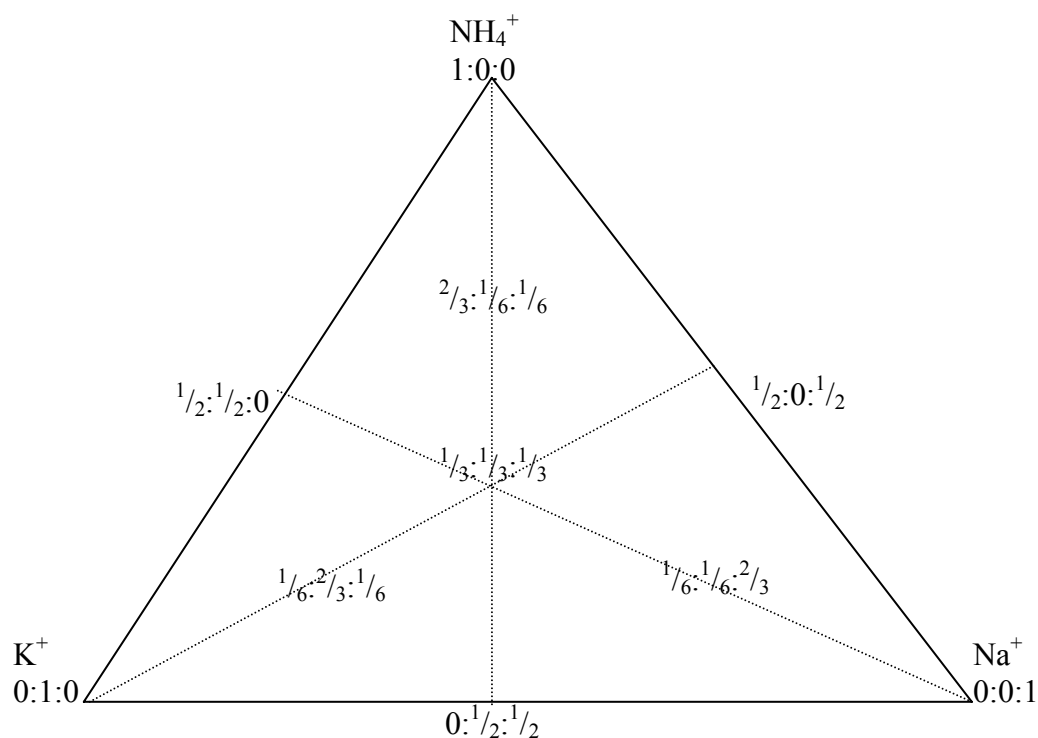

Fig. 6.3. Simplex centroid mixture design augmented with three interior points. Dotted lines represent the coordinates for  $\text{NH}_4^+$ ,  $\text{K}^+$ , and  $\text{Na}^+$ .

Table 6.1. Mixtures utilized for Experiment 6.1 indicating respective proportion and concentration of counter-cations.

Mixtures	Proportion			Concentration (mM)		
	$\text{NH}_4^+$	$\text{K}^+$	$\text{Na}^+$	$\text{NH}_4^+$	$\text{K}^+$	$\text{Na}^+$
Pure blends	1	0	0	5	0	0
	0	1	0	0	5	0
	0	0	1	0	0	5
Binary blends	$1/2$	$1/2$	0	2.5	2.5	0
	$1/2$	0	$1/2$	2.5	0	2.5
	0	$1/2$	$1/2$	0	2.5	2.5
Centroid	$1/3$	$1/3$	$1/3$	1.66	1.66	1.66
Tertiary blends	$2/3$	$1/6$	$1/6$	3.34	0.83	0.83
	$1/6$	$2/3$	$1/6$	0.83	3.34	0.83
	$1/6$	$1/6$	$2/3$	0.83	0.83	3.34

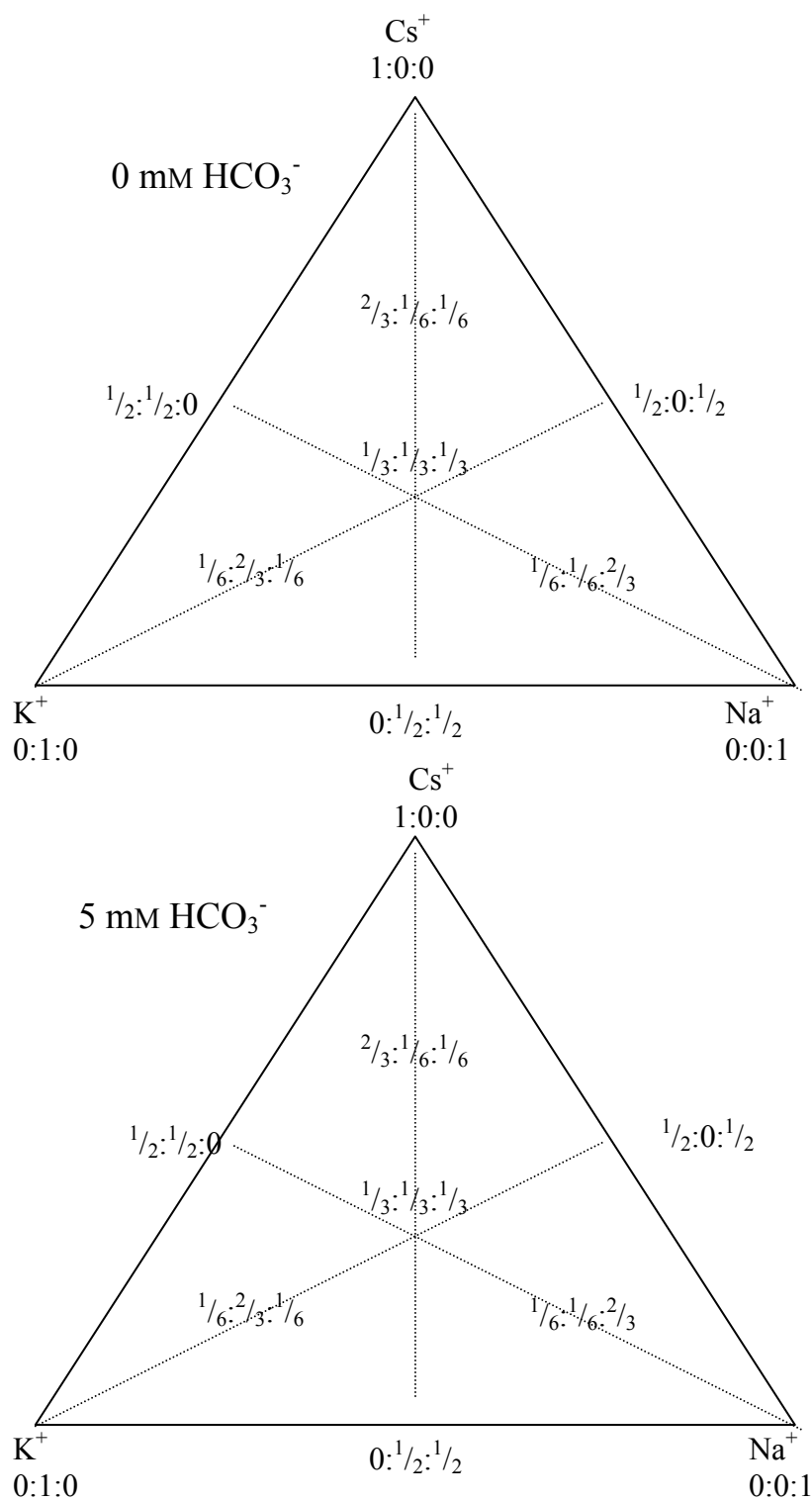

Fig. 6.4. Mixture-amount experiment design consisting of two concentrations of  $\text{HCO}_3^-$ , each was a simplex centroid mixture design augmented with three interior points. Dotted lines represent the  $\text{Cs}^+$ ,  $\text{K}^+$ , and  $\text{Na}^+$  coordinates.

3 Nov and established in a controlled environment chamber. Plants were established in a 25%-strength, modified Hoagland's nutrient solution for seven days (see Table A12, appendix), after which, treatment with mixture solutions started. The total concentration of the mixtures was 5 mM as indicated in Table 6.2. Each  $\text{Cs}^+:\text{K}^+:\text{Na}^+$  mixture was prepared at two concentrations of  $\text{HCO}_3^-$ , 0 and 5 mM (Table A14, appendix). The 0 mM  $\text{HCO}_3^-$  treatments acted as a control to compare the effect of  $\text{HCO}_3^-$ . The sources of  $\text{Na}^+$ ,  $\text{K}^+$ , and  $\text{Cs}^+$  in the treatments with no  $\text{HCO}_3^-$  were  $\text{Na}_2\text{SO}_4$ ,  $\text{K}_2\text{SO}_4$  and  $\text{Cs}_2\text{SO}_4$ . Solutions with  $\text{HCO}_3^-$  were prepared with  $\text{NaHCO}_3$ ,  $\text{KHCO}_3$ , and  $\text{CsHCO}_3$ . All nutrient solutions contained complete Hoagland's formulation for N, Ca, Mg, and micronutrients (Table A14, appendix).

### **Experiment 6.3. Effect of Mixtures of $\text{Rb}^+$ , $\text{K}^+$ , and $\text{Na}^+$ on the Response of Bean Plants to $\text{HCO}_3^-$**

The experiment design was a mixture-amount experiment with three components replicated at two concentrations of  $\text{HCO}_3^-$ , similar to the design used in Experiment 6.2 (Fig. 6.4) but  $\text{Cs}^+$  was substituted by  $\text{Rb}^+$  to avoid  $\text{Cs}^+$  toxicity. The objective was to evaluate the response to  $\text{HCO}_3^-$  in solution with three counter-cations:  $\text{Rb}^+$ ,  $\text{K}^+$ , and  $\text{Na}^+$ .

This experiment was carried out with the methodology indicated in Experiment 6.2. Preparation of plants, growth in controlled environment chambers and container dimensions were as described in Experiment 6.2. A 50%-strength, modified Hoagland's nutrient solution was used as pre-culture solution (Table A15, appendix). Seeds were germinated on 6 Feb. 2002 and seedlings transferred to containers on 13 Feb. On 23 Feb. treatments started and plants were harvested on 15 Mar.

Parameters and experimental design were as described in Experiment 6.1, except that leaf number was not included. Total water consumption was recorded by measuring weekly water consumed. Total chlorophyll was estimated by using a linear regression model that estimated the relationship between chlorophyll content and the SPAD index. The model was obtained with the data recorded in Experiment 6.1. The model is: Total chlorophyll ( $\mu\text{g}\cdot\text{cm}^{-2}$ ) =  $0.2944x + 13.054$ ,  $R^2 = 0.81$  (Fig A1, appendix).

Table 6.2. Mixtures utilized for Experiment 6.2 indicating respective proportion and concentration of counter-cations and  $\text{HCO}_3^-$ .

Mixtures	Proportions			Concentration (mM)			
	$\text{Cs}^+$	$\text{K}^+$	$\text{Na}^+$	$\text{Cs}^+$	$\text{K}^+$	$\text{Na}^+$	$\text{HCO}_3^-$
				0 mM $\text{HCO}_3^-$			
Pure blends	1	0	0	5	0	0	0
	0	1	0	0	5	0	0
	0	0	1	0	0	5	0
Binary blends	$\frac{1}{2}$	$\frac{1}{2}$	0	2.5	2.5	0	0
	$\frac{1}{2}$	0	$\frac{1}{2}$	2.5	0	2.5	0
	0	$\frac{1}{2}$	$\frac{1}{2}$	0	2.5	2.5	0
Centroid	$\frac{1}{3}$	$\frac{1}{3}$	$\frac{1}{3}$	1.66	1.66	1.66	0
Tertiary blends	$\frac{2}{3}$	$\frac{1}{6}$	$\frac{1}{6}$	3.34	0.83	0.83	0
	$\frac{1}{6}$	$\frac{2}{3}$	$\frac{1}{6}$	0.83	3.34	0.83	0
	$\frac{1}{6}$	$\frac{1}{6}$	$\frac{2}{3}$	0.83	0.83	3.34	0
				5 mM $\text{HCO}_3^-$			
Pure blends	1	0	0	5	0	0	5
	0	1	0	0	5	0	5
	0	0	1	0	0	5	5
Binary blends	$\frac{1}{2}$	$\frac{1}{2}$	0	2.5	2.5	0	5
	$\frac{1}{2}$	0	$\frac{1}{2}$	2.5	0	2.5	5
	0	$\frac{1}{2}$	$\frac{1}{2}$	0	2.5	2.5	5
Centroid	$\frac{1}{3}$	$\frac{1}{3}$	$\frac{1}{3}$	1.66	1.66	1.66	5
Tertiary blends	$\frac{2}{3}$	$\frac{1}{6}$	$\frac{1}{6}$	3.34	0.83	0.83	5
	$\frac{1}{6}$	$\frac{2}{3}$	$\frac{1}{6}$	0.83	3.34	0.83	5
	$\frac{1}{6}$	$\frac{1}{6}$	$\frac{2}{3}$	0.83	0.83	3.34	5

The  $\text{Rb}^+:\text{K}^+:\text{Na}^+$  concentration of the total mixture was 7.5 mM, as indicated in Table 6.3. Each  $\text{Rb}^+:\text{K}^+:\text{Na}^+$  mixture was prepared at two concentrations of  $\text{HCO}_3^-$ , 0 and 7.5 mM. Mixtures containing no  $\text{HCO}_3^-$  were prepared with  $\text{Na}_2\text{SO}_4$ ,  $\text{K}_2\text{SO}_4$ , and  $\text{Rb}_2\text{SO}_4$  (Table A16, Appendix). Mixtures containing  $\text{HCO}_3^-$  were prepared with  $\text{NaHCO}_3$ ,  $\text{KHCO}_3$ , and  $\text{RbHCO}_3$ . Rubidium bicarbonate was synthesized by bubbling pure  $\text{CO}_2$  gas into a concentrated solution of  $\text{RbOH}$  until pH stabilized at 8.25 to 8.35 (Dr. Richard H. Loeppert, Texas A&M University, Department of Soil and Crop Sciences, personal communication). Phosphorus and  $\text{K}^+$  were supplied at 0.5 mM as indicated in Experiment 6.2, but no  $\text{Na}^+$  was used. Average initial solution pH was 6.34



Table 6.3. Mixtures utilized for Experiment 6.3 indicating respective proportion and concentration of counter-cations and  $\text{HCO}_3^-$ .

	Proportion			Concentration			
	$\text{Rb}^+$	$\text{K}^+$	$\text{Na}^+$	mM			
				$\text{Rb}^+$	$\text{K}^+$	$\text{Na}^+$	$\text{HCO}_3^-$
$0 \text{ mM HCO}_3^-$							
Pure blends	1	0	0	7.5	0	0	0
	0	1	0	0	7.5	0	0
	0	0	1	0	0	7.5	0
Binary blends	$\frac{1}{2}$	$\frac{1}{2}$	0	3.75	3.75	0	0
	$\frac{1}{2}$	0	$\frac{1}{2}$	3.75	0	3.75	0
	0	$\frac{1}{2}$	$\frac{1}{2}$	0	3.75	3.75	0
Centroid	$\frac{1}{3}$	$\frac{1}{3}$	$\frac{1}{3}$	2.5	2.5	2.5	0
Tertiary blends	$\frac{2}{3}$	$\frac{1}{6}$	$\frac{1}{6}$	5	1.25	1.25	0
	$\frac{1}{6}$	$\frac{2}{3}$	$\frac{1}{6}$	1.25	5	1.25	0
	$\frac{1}{6}$	$\frac{1}{6}$	$\frac{2}{3}$	1.25	1.25	5	0
$7.5 \text{ mM HCO}_3^-$							
Pure blends	1	0	0	7.5	0	0	7.5
	0	1	0	0	7.5	0	7.5
	0	0	1	0	0	7.5	7.5
Binary blends	$\frac{1}{2}$	$\frac{1}{2}$	0	3.75	3.75	0	7.5
	$\frac{1}{2}$	0	$\frac{1}{2}$	3.75	0	3.75	7.5
	0	$\frac{1}{2}$	$\frac{1}{2}$	0	3.75	3.75	7.5
Centroid	$\frac{1}{3}$	$\frac{1}{3}$	$\frac{1}{3}$	2.5	2.5	2.5	7.5
Tertiary blends	$\frac{2}{3}$	$\frac{1}{6}$	$\frac{1}{6}$	5	1.25	1.25	7.5
	$\frac{1}{6}$	$\frac{2}{3}$	$\frac{1}{6}$	1.25	5	1.25	7.5
	$\frac{1}{6}$	$\frac{1}{6}$	$\frac{2}{3}$	1.25	1.25	5	7.5

and 7.90 for mixtures containing 0 and 7.5 mM  $\text{HCO}_3^-$ , respectively. Electric conductivity was 2.18 and 2.13  $\text{dS}\cdot\text{m}^{-1}$ , respectively. Potassium concentration was analyzed on leaves, stem and root tissues of plants grown on selected mixtures. Tissue analysis was conducted on an ICP (SpectroCirus<sup>CCD</sup> Type: 76004527 4LOO76, Cirrus, Fitchburg, MA),<sup>b</sup> at the Soil, Water and Forage Testing Lab, in the Soil and Crop Sciences Department at Texas A&M University in College Station, TX.

#### **Experiment 6.4. Effect of Mixtures of $\text{Rb}^+$ , $\text{K}^+$ , and $\text{Na}^+$ on the Response of Bean Plants to $\text{HCO}_3^-$**

Materials, methods, and mixture experiment design were the same as indicated for Experiment 6.3, except for the one-day with no treatment solution. In this one day, the solution supplied P and  $\text{K}^+$  once a week. The P-K solution was prepared with  $\text{K}_2\text{SO}_4$ ,  $\text{KH}_2\text{PO}_4$ , and  $\text{K}_2\text{HPO}_4$  to provide 5 mM K and 1 mM P. Seeds were germinated on 5 Apr. 2002 and seedlings transplanted on 12 Apr. 2002. Treatments started one week after transferring plants to the containers. Harvest of plants was on 12 May. The parameters measured were those as indicated in Experiment 6.3, except water consumption. The number of leavers was also measured.

#### **Experiment 6.5. Response of Bean Plants to Alkalinity Induced by $\text{NaHCO}_3$ and $\text{KHCO}_3$**

The experimental design was a completely randomized factorial experiment with two sources of  $\text{HCO}_3^-$ ,  $\text{NaHCO}_3$  or  $\text{KHCO}_3$ , at various concentrations. The objective was to differentiate the response of bean plants to  $\text{HCO}_3^-$  as affected by two counter-cations,  $\text{K}^+$  and  $\text{Na}^+$ .

Pinto bean seeds (*Phaseolus vulgaris* L.) ‘Poncho’ (Syngenta, Inc. NC) were germinated and transplanted as described in experiments 6.1 to 6.4, on 31 Oct. and 4 Nov. 2002, respectively. Seedlings were established for one week in a complete nutrient solution (Table A17, appendix). Treatments were 0, 2.5, 5, 7.5, 10, 15, 20, 25, and 30 mM of either  $\text{NaHCO}_3$  or  $\text{KHCO}_3$  (Table A18, appendix). Table 6.4 shows the resulting pH and EC for each concentration.

Table 6.4. Resulting pH and EC for the NaHCO<sub>3</sub> and KHCO<sub>3</sub> concentrations evaluated.

Concentration mM	NaHCO <sub>3</sub>		KHCO <sub>3</sub>	
	pH	EC dS·m <sup>-1</sup>	pH	EC dS·m <sup>-1</sup>
0	7.25	2.30	7.25	2.02
2.5	7.94	2.50	7.92	2.05
5	8.02	2.70	7.92	2.10
7.5	8.09	2.60	7.92	2.30
10	8.16	2.80	7.99	2.50
15	8.16	3.00	8.09	2.90
20	8.32	3.20	8.25	3.10
25	8.33	3.60	8.49	3.50
30	8.57	3.80	8.66	3.80

All the treatments with NaHCO<sub>3</sub> contained 5 mM K<sup>+</sup> (to avoid K<sup>+</sup> deficiency) while in treatments with KHCO<sub>3</sub>, K<sup>+</sup> content was according to the concentration of KHCO<sub>3</sub>, thus the control solution (with no HCO<sub>3</sub><sup>-</sup>) contained no K<sup>+</sup>. Plants were grown in a controlled environment chamber as in Experiments 6.1 to 6.4.

Five replications per treatment were distributed in a completely randomized factorial experimental design, and data analyzed by ANOVA and LSD multiple mean comparison (SAS Institute, Inc. N.C.). Harvest was completed on 8 Dec. 2002 and the parameters measured were solution final pH, root fresh and dry mass, leaf fresh and dry mass, shoot fresh and dry mass, total chlorophyll, and leaf area. Total chlorophyll was determined as indicated in Experiment 6.1 and leaf area as indicated for previous experiments.

### **Experiment 6.6. Effect of $K^+ : Na^+$ Binary Mixtures on the Response of Bean Plants to $HCO_3^-$**

The experimental design was a mixture-amount experiment with two components,  $K^+$  and  $Na^+$ , and two concentrations of  $HCO_3^-$ . The mixture-amount experiment was replicated at three total concentrations, 2.5, 5, and 7.5 mM (Fig. 6.5).

The objective was to assess the effect of the  $K^+ : Na^+$  binary mixtures on the response of bean plants to  $HCO_3^-$ .

Pinto bean seeds (*Phaseolus vulgaris* L.) 'Poncho' (Syngenta, Inc. NC) were germinated similarly to previous mixture experiments on 20 Mar. 2003 and the seedlings were transferred to containers on 29 Mar. 2003. The pre-culture nutrient solution was a 100%-strength, modified Hoagland's solution (Table A17, appendix). Plants were grown in a controlled environment chamber in which environmental conditions were handled as described in Experiments 6.1 to 6.5. The experimental design was a completely randomized design with 4 replications, one plant per replication. Solutions were replaced every week.

Phosphorus was supplemented as indicated in previous experiments at a concentration of 1 mM prepared with  $(NH_4)_2HPO_4$  and  $(NH_4)_2HPO_4$ . Phosphorus solution pH was prepared to have a final pH of 6.3. Mixtures with  $HCO_3^-$  were prepared with  $NaHCO_3$  and  $KHCO_3$ , and mixtures with no  $HCO_3^-$  with  $Na_2SO_4$  and  $K_2SO_4$  (Table A19, appendix).

In this experiment, five proportions of each total concentration were evaluated in order to attain more precision in the estimation (Table 6.5).

Data was analyzed with Design Expert© version 6.0.4 (Stat-Ease, Inc. Mn), a computer program, to obtain effects of the treatments, counter plots and analysis of variance. Harvest was on 27 Apr. 2003 and the parameters studied were leaf area, fresh and dry shoot mass, fresh and dry root mass, and leaf fresh and dry mass.

Solution final pH, total chlorophyll concentration, shoot:root ratio, and water consumption were determined as indicated in Experiment 6.3.

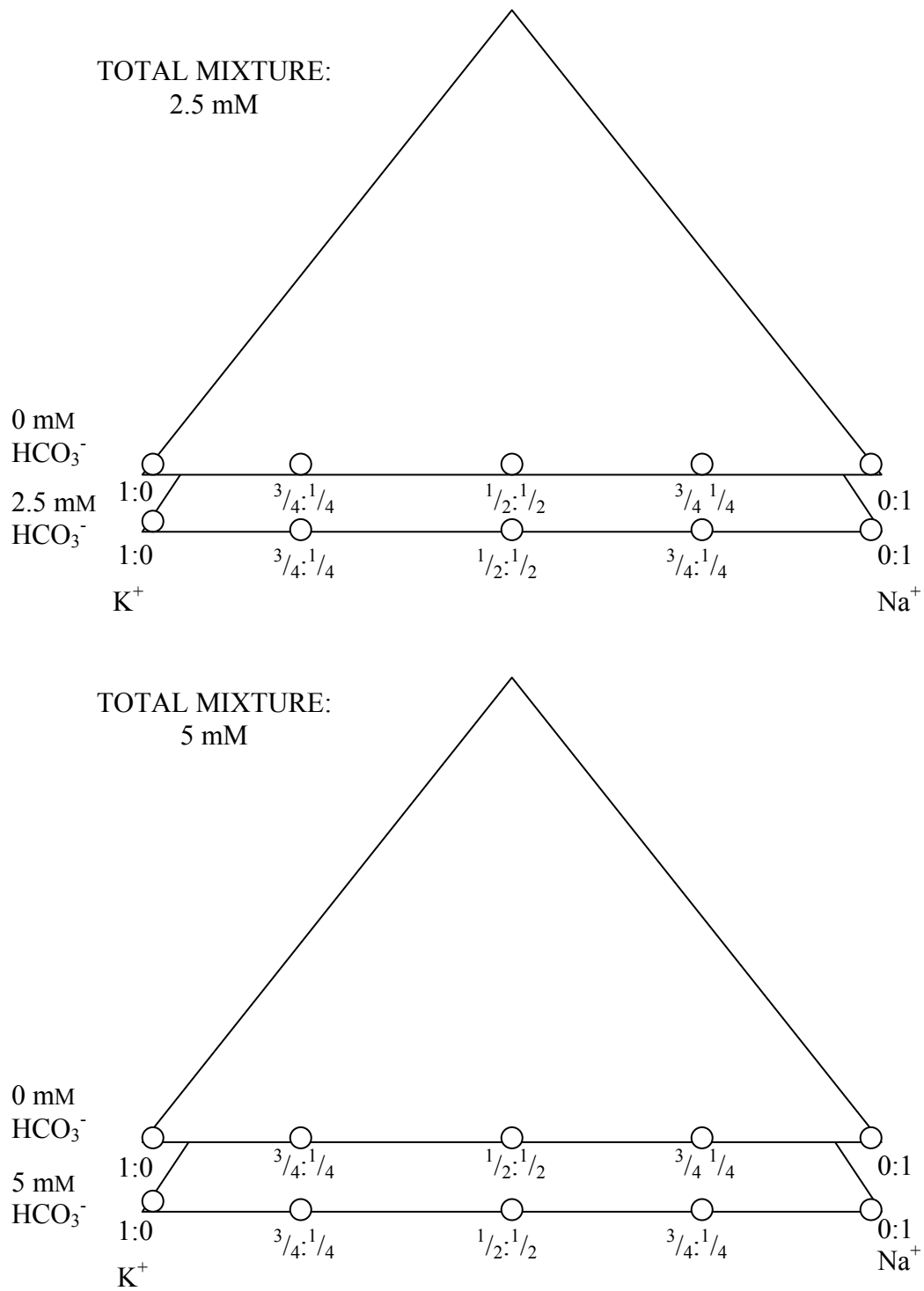

Fig. 6.5. Two-component mixture-amount designs at three total mixtures.

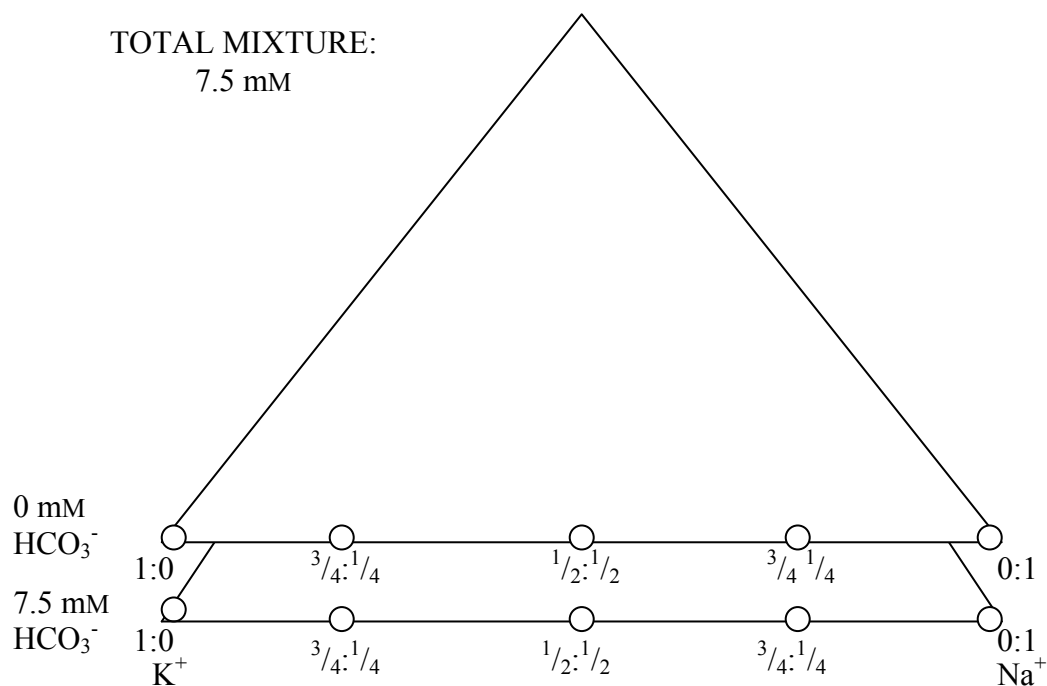

Fig. 6.5. Continue.

Net  $\text{K}^+$  and  $\text{Na}^+$  uptake rate were measured in 4 d old intact seedlings germinated as indicated previously. Seedlings were placed during 26 h in 50 ml disposable tubes and roots immersed in a  $\text{K}^+:\text{Na}^+$  solution with a total mixture of 7.5 mM. Tubes were covered with aluminum foil to prevent light from reaching the roots. Air was bubbled constantly through a manifold system with a 1 HP air pump. Seedlings were maintained in a growth chamber with controlled environment such as indicated previously. The mixtures evaluated were 1:0,  $1/2:1/2$ , and 0:1 at two levels of  $\text{HCO}_3^-$ , 0 and 7.5 mM. After uptake period, seedlings were retired from the tubes, roots were weighed and  $\text{K}^+$  and  $\text{Na}^+$  depletion from the solution were measured in a Horiba C-122 cardi meter (Spectrum Technologies, Inc. Plainfill, IL.).

Table 6.5. Mixtures utilized for Experiment 6.6 indicating respective proportion and concentration of counter-cations,  $\text{HCO}_3^-$ .

Mixture $\text{K}^+ : \text{Na}^+$	Concentration mM			pH	EC $\text{dS}\cdot\text{m}^{-1}$
	$\text{K}^+$	$\text{Na}^+$	$\text{HCO}_3^-$		
Total $\text{K}^+ + \text{Na}^+$ concentration 2.5 mM					
0 mM $\text{HCO}_3^-$					
1:0	2.5	0	0	6.54	1.77
$3/4 : 1/4$	1.88	0.63	0	6.63	1.73
$1/2 : 1/2$	1.25	1.25	0	6.07	1.69
$1/4 : 3/4$	0.63	1.88	0	6.54	1.65
0:1	0	2.5	0	5.41	1.71
2.5 mM $\text{HCO}_3^-$					
1:0	2.5	0	2.5	7.95	1.63
$3/4 : 1/4$	1.88	0.63	2.5	7.57	1.61
$1/2 : 1/2$	1.25	1.25	2.5	7.95	1.63
$1/4 : 3/4$	0.63	1.88	2.5	7.57	1.67
0:1	0	2.5	2.5	7.57	1.73
Total $\text{K}^+ + \text{Na}^+$ concentration 5 mM					
0 mM $\text{HCO}_3^-$					
1:0	5	0	0	4.18	1.86
$3/4 : 1/4$	3.75	1.25	0	4.18	1.80
$1/2 : 1/2$	2.5	2.5	0	4.37	1.94
$1/4 : 3/4$	1.25	3.75	0	4.14	1.92
0:1	0	5	0	4.46	1.59
5 mM $\text{HCO}_3^-$					
1:0	5	0	5	7.57	1.94
$3/4 : 1/4$	3.75	1.25	5	7.39	1.85
$1/2 : 1/2$	2.5	2.5	5	7.39	1.80
$1/4 : 3/4$	1.25	3.75	5	7.39	1.65
0:1	0	5	5	7.48	1.78
Total $\text{K}^+ + \text{Na}^+$ concentration 7.5 mM					
0 mM $\text{HCO}_3^-$					
1:0	7.5	0	0	4.09	2.30
$3/4 : 1/4$	5.63	1.87	0	4.18	2.00
$1/2 : 1/2$	3.75	3.75	0	4.18	2.10
$1/4 : 3/4$	1.87	5.63	0	4.46	1.94
0:1	0	7.5	0	4.46	1.99
7.5 mM $\text{HCO}_3^-$					
1:0	7.5	0	7.5	7.85	1.76
$3/4 : 1/4$	5.63	1.87	7.5	7.39	1.98
$1/2 : 1/2$	3.75	3.75	7.5	7.48	1.90
$1/4 : 3/4$	1.87	5.63	7.5	7.67	1.86
0:1	0	7.5	7.5	7.57	1.41

## RESULTS

### Experiment 6.1. Effect of Mixtures of $\text{Na}^+$ , $\text{K}^+$ , and $\text{NH}_4^+$ on the Response of Bean Plants to $\text{HCO}_3^-$

#### *Shoot and root mass*

#### Models

The response to  $\text{HCO}_3^-$  on shoot and root mass was affected significantly ( $P \leq 0.05$ ) by the proportion of  $\text{NH}_4^+$ ,  $\text{K}^+$ , and  $\text{Na}^+$  in 5 mM total mixtures, according to ANOVA (Table 6.6).

Shoot and root mass best fit special cubic and linear models, respectively (Table 6.7). The plant response is demonstrated in the response surface and counter-plot in Fig. 6.6.

#### Pure blends (vertices)

According to the models, shoot and root mass were greater in the pure  $\text{K}^+$  blend (0:1:0, mixture), followed by the  $\text{Na}^+$  and  $\text{NH}_4^+$  pure blends (0:0:1 and 1:0:0 mixtures, respectively)(see the coefficients  $\beta_2$ ,  $\beta_3$ , and  $\beta_1$ , respectively, in Table 6.7).

Using the pure  $\text{K}^+$  blend, 0:1:0 mixture, as the reference point, shoot and root dry mass were decreased by 15% and 27%, respectively, by the  $\text{Na}^+$  pure blend. The decrease was 71% and 76% with the  $\text{NH}_4^+$  pure blend (1:0:0 mixture). The 95% confidence interval for the shoot and root dry mass prediction for both  $\text{K}^+$  and  $\text{Na}^+$  pure blends did not overlap with that for  $\text{NH}_4^+$  (Table 6.8), indicating a significant difference. In the vertices for  $\text{K}^+$  and  $\text{Na}^+$  shoot mass confidence interval is overlapped, but not for the root mass (Table 6.8).

The results indicated that for pure blends the toxicity of the counter-cations were ranked  $\text{NH}_4^+ > \text{Na}^+ \approx \text{K}^+$ . Since  $\text{K}^+$  and  $\text{Na}^+$  were not significantly different, there appears not to be a specific  $\text{Na}^+$  toxicity affecting shoot growth.

#### Coordinates (0% to 100% blends)

The coordinate for  $\text{NH}_4^+$  (Fig. 6.6) indicated that as the proportion of  $\text{NH}_4^+$  increased from 0 to  $1/3$ , shoot mass increased, but when the proportion was higher than



Table 6.6. Effect of mixtures of varying proportions of  $\text{NH}_4^+$ ,  $\text{K}^+$ , and  $\text{Na}^+$  counter-cations of  $\text{HCO}_3^-$  on shoot, root, and leaf growth parameters of bean, *Phaseolus vulgaris* L. ‘Poncho’, plants grown in hydroponics with a 5 mM total concentration. Experiment 6.1.

Mixtures $\text{NH}_4^+:\text{K}^+:\text{Na}^+$	Shoot Dry Mass <sup>z</sup> (g)	Shoot Fresh Mass (g)	Root Dry Mass (g)	Root Fresh Mass (g)	Leaf Dry Mass (g)	Leaf Fresh Mass (g)
Pure blends						
1:0:0	2.01d	19.3d	0.9d	15.2e	1.9d	12.9d
0:1:0	6.53abc	79.5a	3.9a	78.4a	6.8a	54.2a
0:0:1	4.98bc	57.8bc	3.1ab	58.9abc	5.3abc	40.8abc
Binary blends						
$1/2:1/2:0$	6.73abc	70.6a	2.5bc	47.5bcd	6.0abc	48.1ab
$1/2:0:1/2$	4.61c	46.6c	1.7cd	31.7de	4.2bcd	33.4bc
$0:1/2:1/2$	1.90d	45.4c	3.7a	78.6a	3.5cd	31.2c
Centroid						
$1/3:1/3:1/3$	7.07ab	70.9a	3.1ab	60.2abc	6.4ab	48.3ab
Tertiary blends						
$2/3:1/6:1/6$	5.76abc	57.2b	2.0c	40.1cd	5.0abc	39.1abc
$1/6:2/3:1/6$	6.37abc	69.1ab	3.2ab	66.6ab	6.0abc	49.5ab
$1/6:1/6:2/3$	7.33a	73.6a	2.5 bc	49.8bcd	6.4ab	50.6a
Significance <sup>y</sup>	***	***	***	***	***	***
$R^2$	0.68	0.84	0.89	0.87	0.79	0.79
CV%	27.63	14.71	12.92	16.52	20.83	17.02

<sup>z</sup>Means followed by the same letter indicates non-significant difference according to the LSD multiple comparison test at  $P \leq 0.05$

<sup>y</sup>Significance according to ANOVA, NS, \*, \*\*, \*\*\* Non significant, and significant at  $P \leq 0.05$ ,  $P \leq 0.01$ , and  $P \leq 0.001$ , respectively

$R^2$ = Coefficient of determination

CV= Coefficient of variation

Table 6.7. Models<sup>z</sup> for the shoot, root, and leaf growth parameters of bean, *Phaseolus vulgaris* L. ‘Poncho’, plants in response to NH<sub>4</sub><sup>+</sup>:K<sup>+</sup>:Na<sup>+</sup> mixtures with a 5 mM total concentration. Experiment 6.1.

Coefficient <sup>y</sup>	Shoot Dry Mass (g)	Shoot Fresh Mass (g)	Root Dry Mass (g)	Root Fresh Mass (g)	Leaf Dry Mass (g)	Leaf Fresh Mass (g)
β <sub>1</sub>	+1.87	+12.6	+0.97	+16.2	+1.89	+12.8
β <sub>2</sub>	+6.42	+53.4	+4.06	+82.9	+6.68	+53.4
β <sub>3</sub>	+5.43	+42.8	+2.97	+59.0	+5.51	+42.8
β <sub>4</sub>	+9.33	+56.2	-	-	+6.22	+55.9
β <sub>5</sub>	+5.08	+30.2	-	-	+2.73	+29.8
β <sub>6</sub>	-14.65	-63.2	-	-	-10.04	-63.2
β <sub>7</sub>	+84.85	+334.7	-	-	+56.71	+335.0
Model	Special cubic	Special cubic	Linear	Linear	Special cubic	Special cubic
Lack of fit <sup>x</sup>	<i>P</i> = 0.116	<i>P</i> = 0.141	<i>P</i> = 0.117	<i>P</i> = 0.117	<i>P</i> = 0.312	<i>P</i> = 0.141
Adeq. Prec.	9.08	13.46	25.98	25.98	10.74	13.41
<i>R</i> <sup>2</sup>	0.62	0.75	0.81	0.81	0.69	0.75
CV%	28.67	17.75	17.78	25.98	17.78	14.58

<sup>z</sup>To estimate any parameter, multiply the coefficients indicated in the table by the proportion of the corresponding counter-ion in the mixture of interest

<sup>y</sup>β<sub>1</sub>: NH<sub>4</sub><sup>+</sup>, β<sub>2</sub>: K<sup>+</sup>, β<sub>3</sub>: Na<sup>+</sup>, β<sub>4</sub>: NH<sub>4</sub><sup>+</sup>\*K<sup>+</sup>, β<sub>5</sub>: NH<sub>4</sub><sup>+</sup>\*Na<sup>+</sup>, β<sub>6</sub>: K<sup>+</sup>\* Na<sup>+</sup>, β<sub>7</sub>: NH<sub>4</sub><sup>+</sup>\* K<sup>+</sup>\*Na<sup>+</sup>

<sup>x</sup>Lack of fit according to ANOVA

Adeq. Prec.=Adequate precision

*R*<sup>2</sup>= Coefficient of determination

CV= Coefficient of variation

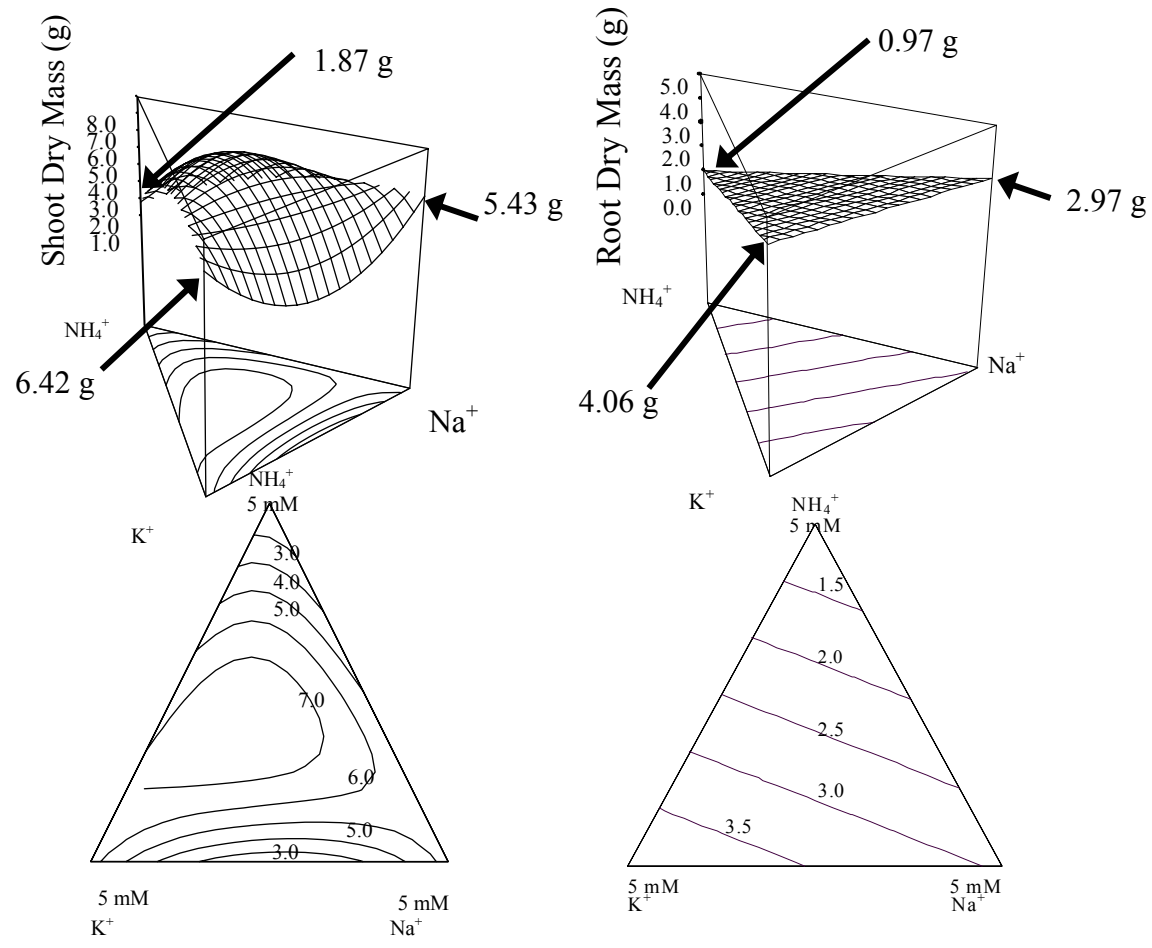

Fig. 6.6. Effect of mixtures of varying proportions of  $\text{NH}_4^+$ ,  $\text{K}^+$ , and  $\text{Na}^+$  as counter-cations of  $\text{HCO}_3^-$  on shoot and root dry mass of bean, *Phaseolus vulgaris* L. 'Poncho', grown in hydroponics with 5 mM total concentration. Top figures are 3-dimensional response surface and lower figures are counter plots.

Table 6.8. Predicted response and 95% confidence interval for some growth parameters evaluated of bean, *Phaseolus vulgaris* L. ‘Poncho’, plants grown in mixtures of varying proportions of  $\text{NH}_4^+$ ,  $\text{K}^+$ , and  $\text{Na}^+$  counter-cations of  $\text{HCO}_3^-$  in hydroponics with a 5 mM total concentration. Experiment 6.1.

Mixtures $\text{NH}_4^+:\text{K}^+:\text{Na}^+$	Shoot Dry Mass (g)		Root Dry Mass (g)			Leaf Area ( $\text{cm}^2$ )		Solution Final pH		Total Chlorophyll ( $\mu\text{g}\cdot\text{cm}^{-2}$ )					
	$\text{CI}_L^z$	$\text{CI}_H^y$	$\text{CI}_L$	$\text{CI}_H$	$\text{CI}_L$	$\text{CI}_H$	$\text{CI}_L$	$\text{CI}_H$	$\text{CI}_L$	$\text{CI}_H$					
Pure blends															
1:0:0	0.36	1.90	3.37	0.68	0.97	1.26	104.4	487.4	870.5	6.51	7.02	7.52	8.57	10.4	12.3
0:1:0	4.91	6.40	7.92	3.77	4.06	4.35	2367.1	2750.1	3133.2	7.42	7.93	8.43	3.47	5.35	7.22
0:0:1	3.93	5.40	6.94	2.68	2.97	3.26	1617.2	2000.2	2383.3	7.82	8.32	8.83	0.75	2.62	4.50
Binary blends															
$1/2:1/2:0$	4.98	6.50	7.97	2.33	2.52	2.70	1866.3	2246.3	2626.4	7.16	7.47	7.79	4.47	6.33	8.19
$1/2:0:1/2$	3.43	4.90	6.41	1.79	1.97	2.15	1247.1	1627.1	2007.2	7.36	7.67	7.99	1.96	3.82	5.67
$0:1/2:1/2$	0.75	2.20	3.73	3.34	3.52	3.70	1059.7	1439.8	1819.8	7.81	8.13	8.44	2.60	4.45	6.30
Centroid															
$1/3:1/3:1/3$	6.52	7.70	8.93	2.52	2.75	2.77	2239.6	2547.2	1854.7	7.54	7.75	7.97	5.97	7.47	8.98
Tertiary blends															
$2/3:1/6:1/6$	5.18	6.00	6.83	1.61	1.80	1.98	1608.6	1816.2	2023.8	7.06	7.38	7.70	6.97	7.98	9.00
$1/6:2/3:1/6$	5.85	6.70	7.52	3.19	3.37	3.55	2314.4	2524.2	2734.1	7.54	7.85	8.16	5.46	6.48	7.51
$1/6:1/6:2/3$	5.03	5.90	6.70	2.62	2.80	2.98	1889.1	2099.0	2308.9	7.72	8.03	8.34	3.72	4.75	5.78

<sup>z</sup> $\text{CI}_L$ =low confidence interval

<sup>y</sup> $\text{CI}_H$ =high confidence interval

$2/3$ ,  $\text{NH}_4^+$  detrimentally affected plant growth. Plants also exhibited a decrease in root mass as the concentration of  $\text{NH}_4^+$  increased (Fig. 6.6). Thus, a high proportion of  $\text{NH}_4^+$  was associated with toxicity.

The coordinate for  $\text{K}^+$  showed that increasing concentrations promoted both shoot and root mass accumulation (Fig. 6.6). The coordinate for  $\text{Na}^+$  indicated that shoot mass increased at proportions between 0 and  $1/3$ , but higher proportions were detrimental (Fig. 6.6). Thus,  $\text{Na}^+$  was also toxic for shoot growth. Root mass was not markedly affected by increasing proportions of  $\text{Na}^+$  (Fig. 6.6).

#### Binary blends (50%:50% blends)

Binary blends of  $\text{NH}_4^+:\text{K}^+$  and  $\text{NH}_4^+:\text{Na}^+$  had a synergistic effect on shoot mass. This was indicated by the positive coefficients,  $\beta_4$  and  $\beta_5$ , respectively (Table 6.7), and the raised response surface of the binary blends in Fig. 6.6. Blends of  $\text{K}^+$  and  $\text{Na}^+$  were antagonistic, as indicated by the negative coefficient,  $\beta_6$  (Table 6.7), and the depressed response surface for the  $\text{K}^+:\text{Na}^+$  binary blend (Fig 6.6).

#### Optimization

The interior points of the response surface reflected the effects of tertiary blends of the three counter-cations. The highest shoot mass on the response surface was in the region of  $\text{K}^+$  above  $1/3$ ,  $\text{Na}^+$  between 0 to  $1/3$ , and  $\text{NH}_4^+$  between 0 to  $2/3$  (Fig. 6.6).

The statistical model allowed prediction of the best and worst blends for highest and lowest plant growth, hence least and maximum toxicity. The models selected predicted the best blend for shoot mass to be 0.38:0.38:0.23  $\text{NH}_4^+:\text{K}^+:\text{Na}^+$ , yielding 7.86 g, and the most detrimental blend to be 1:0:0, yielding 1.87 g. Maximum and minimum root dry mass were predicted to be at the 0:1:0 and 1:0:0 mixtures, respectively.

#### *Leaf growth*

According to ANOVA, leaf growth parameters were significantly decreased by some  $\text{NH}_4^+:\text{K}^+:\text{Na}^+$  treatments (Tables 6.6 and 6.9).

The response to the  $\text{NH}_4^+:\text{K}^+:\text{Na}^+$  mixture is shown in Tables 6.7 and 6.10. Figure 6.6 shows the response surface for leaf area and leaf dry mass. The fitted models, the effect of the pure and binary blends, coordinates, and the blends with the highest and

Table 6.9. Effect of mixtures of varying proportions of  $\text{NH}_4^+$ ,  $\text{K}^+$ , and  $\text{Na}^+$  counter-cations of  $\text{HCO}_3^-$  on leaf area, leaf number, shoot:root ratio, solution pH, and total chlorophyll concentration of bean, *Phaseolus vulgaris* L. 'Poncho', plants grown in hydroponics with a 5 mM total concentration. Experiment 6.1.

Mixtures $\text{NH}_4^+:\text{K}^+:\text{Na}^+$	Leaf Area <sup>z</sup> ( $\text{cm}^2$ )	Leaf Number	Shoot:Root Ratio ( $\text{g}:\text{g}^{-1}$ )	Solution Final pH	Total Chlorophyll ( $\mu\text{g}\cdot\text{cm}^{-2}$ )
Pure blends					
1:0:0	526e	11.8c	3.3a	6.5ab	10.2a
0:1:0	2766a	32.0a	3.0a	8.1ab	5.9bcd
0:0:1	1858bcd	29.5ab	2.6ab	8.3a	2.0e
Binary blends					
$1/2:1/2:0$	2300abc	35.0a	3.7a	7.4ab	6.7abcd
$1/2:0:1/2$	1522cd	28.0ab	3.7a	8.0ab	3.0de
$0:1/2:1/2$	1313de	21.3bc	1.5b	8.1ab	4.4cde
Centroid					
$1/3:1/3:1/3$	2291abc	32.0a	3.2a	7.8ab	6.7abcd
Tertiary blends					
$2/3:1/6:1/6$	1823bcd	27.8ab	3.9a	6.4ab	8.9ab
$1/6:2/3:1/6$	2583ab	33.0a	3.0ab	7.9ab	5.0bcde
$1/6:1/6:2/3$	2599ab	32.8a	4.0a	8.1ab	7.0abc
Significance <sup>y</sup>	***	***	***	*	***
$R^2$	0.84	0.76	0.58	0.44	0.83
CV%	17.32	15.07	21.37	10.96	13.29

<sup>z</sup>Means followed by the same letter indicates non significant difference according to the LSD multiple comparison test at  $P \leq 0.05$

<sup>y</sup>Significance according to ANOVA, NS, \*, \*\*, \*\*\* non significant, and significant at  $P \leq 0.05$ ,  $P \leq 0.01$ , and  $P \leq 0.001$ , respectively

$R^2$ = Coefficient of determination

CV= Coefficient of variation

Table 6.10. Models<sup>z</sup> for leaf area, leaf number, shoot:root ratio, solution pH, and total chlorophyll concentration of bean, *Phaseolus vulgaris* L. ‘Poncho’, plants in response to NH<sub>4</sub><sup>+</sup>:K<sup>+</sup>:Na<sup>+</sup> mixtures with a 5 mM total concentration. Experiment 6.1.

Coefficient <sup>y</sup>	Leaf Area (cm <sup>2</sup> )	Leaf Number	Shoot:Root Ratio (g·g <sup>-1</sup> )	Solution Final pH	Total Chlorophyll (µg·cm <sup>-2</sup> )
β <sub>1</sub>	+487.4	+11.5	+3.25	+7.02	+10.4
β <sub>2</sub>	+2750.1	+31.9	+2.85	+7.93	+5.4
β <sub>3</sub>	+2000.2	+30.3	+2.85	+8.32	+2.6
β <sub>4</sub>	+2510.3	+51.9	+3.01	-	-6.3
β <sub>5</sub>	+1533.2	+30.5	+4.19	-	-10.9
β <sub>6</sub>	-3741.6	-36.6	-3.85	-	+1.9
β <sub>7</sub>	+20929.7	+100.3	-	-	+82.1
Model	Special cubic	Special cubic	Quadratic	Linear	Special cubic
Lack of fit <sup>x</sup>	P=0.010	P=0.503	P=0.049	P=0.181	P=0.006
Adeq. Prec.	13.89	13.12	7.63	7.05	9.82
R <sup>2</sup>	0.76	0.74	0.43	0.24	0.61
CV%	19.89	14.94	23.46	8.47	24.18

<sup>z</sup>To estimate any parameter, multiply the coefficients indicated in the table by the proportion of the corresponding counter-ion in the mixture of interest

<sup>y</sup>β<sub>1</sub>: NH<sub>4</sub><sup>+</sup>, β<sub>2</sub>: K<sup>+</sup>, β<sub>3</sub>: Na<sup>+</sup>, β<sub>4</sub>: NH<sub>4</sub><sup>+</sup>\*K<sup>+</sup>, β<sub>5</sub>: NH<sub>4</sub><sup>+</sup>\*Na<sup>+</sup>, β<sub>6</sub>: K<sup>+</sup>\* Na<sup>+</sup>, β<sub>7</sub>: NH<sub>4</sub><sup>+</sup>\* K<sup>+</sup>\*Na<sup>+</sup>

<sup>x</sup>Lack of fit according to ANOVA

Adeq. Prec.=Adequate precision

R<sup>2</sup>= Coefficient of determination

CV= Coefficient of variation

lowest leaf growth were very similar to the response described for shoot mass. This was reflected in the similarity of the response surfaces and counter-plots obtained for leaf area and leaf dry mass (Fig. 6.7) compared to shoot dry mass (Fig. 6.6).

The model best fitting the leaf area response was a special cubic function (Table 6.10). The model predicted the best blend for leaf area to be the 0.05:0.95:0  $\text{NH}_4^+:\text{K}^+:\text{Na}^+$  mixture, yielding 2756.2  $\text{cm}^2$ . The 95% confidence interval (2415.7-3096.4) did not overlap with the interval estimated for the mixtures 1:0:0, 0: $1/2$ : $1/2$ ,  $1/2$ : $1/2$ :0,  $2/3$ : $1/6$ : $1/6$ , and  $1/6$ : $1/6$ : $2/3$  (Table 6.8). The blend yielding the lowest leaf area, 487.4  $\text{cm}^2$ , was the 1:0:0 mixture.

#### *Shoot:root ratio*

The shoot:root ratio response to  $\text{HCO}_3^-$  was affected significantly ( $P \leq 0.05$ ) by the  $\text{NH}_4^+:\text{K}^+:\text{Na}^+$  treatments according to the ANOVA (Table 6.9). The response to the  $\text{NH}_4^+:\text{K}^+:\text{Na}^+$  mixtures best fit to a quadratic model (Table 6.10).

The coefficients for the pure blends indicated that the largest ratio was obtained with the mixture 1:0:0 ( $\beta_1$ ) (Table 6.10). All the blends containing  $\text{NH}_4^+$  had a positive coefficient ( $\beta_1$ ,  $\beta_4$ , and  $\beta_5$ ), demonstrating that  $\text{NH}_4^+$  has an increasing effect in the shoot:root ratio (Table 6.10).

The coefficients for the binary blends  $\text{NH}_4^+:\text{K}^+$ ,  $\beta_4$ , and  $\text{NH}_4^+:\text{Na}^+$ ,  $\beta_5$ , were positive, indicating a synergistic effect. The coefficient for the mixture of  $\text{K}^+:\text{Na}^+$ ,  $\beta_6$ , was negative, indicating an antagonistic effect (Table 6.10).

#### *Total chlorophyll*

Total chlorophyll concentration response to  $\text{HCO}_3^-$  was affected significantly ( $P \leq 0.05$ ) by the  $\text{NH}_4^+:\text{K}^+:\text{Na}^+$  treatments according to ANOVA (Table 6.9). A special cubic model best fit the response (Table 6.10).

Total chlorophyll concentration increased as the concentration of  $\text{NH}_4^+$  increased (Fig. 6.7). Plants grown in the  $\text{Na}^+$  pure blend (0:0:1 mixture), resulted in the lowest chlorophyll concentration (Table 6.10). The coefficients for the pure blends corroborated the response which was also observed in the response surface of Fig. 6.7. According to the pure blend coefficients, the  $\text{Na}^+$  pure blend induced a 52% decrease in



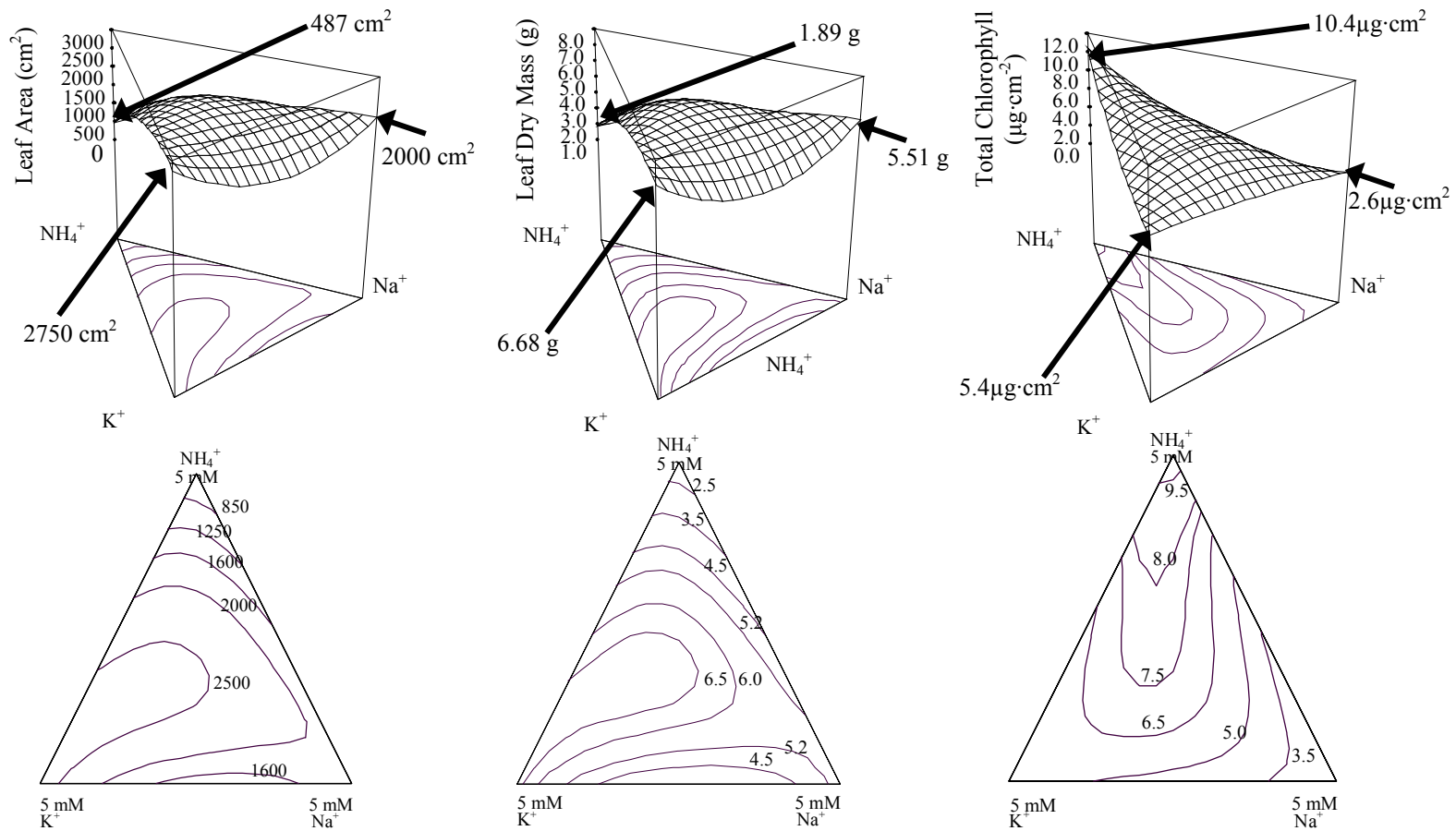

Fig. 6.7. Effect of mixtures of varying proportions of  $\text{NH}_4^+$ ,  $\text{K}^+$ , and  $\text{Na}^+$  as counter-cations of  $\text{HCO}_3^-$  on leaf area, leaf dry mass and total chlorophyll content of bean, *Phaseolus vulgaris* L. 'Poncho', grown in hydroponics with 5 mM total concentration. Top figures are 3-dimensional response surface and lower figures are counter plots.

chlorophyll concentration over the  $K^+$  pure blend. Ammonium induced a 93% increase in chlorophyll concentration. This indicated that for pure blends the content of chlorophyll was ranked  $NH_4^+ > K^+ > Na^+$ .

The confidence interval for the maximum predicted response in the  $NH_4^+$  pure blend,  $10.4 \mu\text{g}\cdot\text{cm}^{-2}$ , did not overlap with most of the intervals of the remaining mixtures, except for the blend  $1/3:1/3:1/3$  (Table 6.8).

#### *Solution final pH*

Solution final pH response to  $HCO_3^-$  was significantly affected ( $P \leq 0.05$ ) by the  $NH_4^+ : K^+ : Na^+$  treatments according to ANOVA (Table 6.9). The best fit was a linear model (Table 6.10).

The coefficients of the linear model demonstrated that pH of solutions containing  $Na^+$  ( $\beta_3$ ) was higher than that of solutions containing  $K^+$  ( $\beta_2$ ) and  $NH_4^+$  ( $\beta_1$ ) (Table 6.10). This was supported by the non-overlapping confidence intervals (Table 6.8).

#### *Discussion*

The proportion of the  $NH_4^+$ ,  $K^+$ , and  $Na^+$  counter-cations modified the response of bean plants to  $HCO_3^-$  at 5 mM. Shoot dry mass (Fig. 6.6), root dry mass (Fig. 6.6), and total chlorophyll concentration (Fig. 6.7) represented the typical response of plants to the mixtures.

In general, shoot and root mass responded to the mixtures in the following ranking (low to high growth; high to low toxicity):

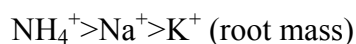

Total chlorophyll ranking was (low to high concentration; high to low toxicity):



and for final solution pH was (low to high pH; high to low pH):



#### *Shoot growth*

*$NH_4^+$  Effect.* Increasing the proportion of  $NH_4^+$  caused a decrease in shoot growth (Fig. 6.6). This might have been caused by the decreasing  $NO_3^- : NH_4^+$  ratios as

the proportion of  $\text{NH}_4^+$  in the mixtures increased. The total concentration of N in nutrient solutions was maintained at 10 mM. As the proportion of  $\text{NH}_4^+$  in the mixtures increased, the concentration of  $\text{NO}_3^-$  was decreased to maintain constant concentration of N. The  $0:\frac{1}{2}:\frac{1}{2}$  binary blend contained a 1:0  $\text{NO}_3^-:\text{NH}_4^+$  ratio. The centroid,  $\frac{1}{3}:\frac{1}{3}:\frac{1}{3}$ , and tertiary blend,  $\frac{2}{3}:\frac{1}{6}:\frac{1}{6}$ , had a 0.83:0.17 and 0.67:0.33  $\text{NO}_3^-:\text{NH}_4^+$  ratio, respectively. The  $\text{NH}_4^+$  pure blend had a 0.5:0.5  $\text{NO}_3^-:\text{NH}_4^+$  ratio.

A high proportion of  $\text{NH}_4^+$  resulted in toxicity in sunflower when the  $\text{NO}_3^-:\text{NH}_4^+$  ratio was higher than 0.75:0.25 (Fig. 5.3). In present experiment, the proportion of  $\text{NH}_4^+$  surpassed the 0.75:0.25 ratio at the  $\frac{2}{3}:\frac{1}{6}:\frac{1}{6}$  blend. This may explain why shoot mass of bean plants decreased when the proportion of  $\text{NH}_4^+$  in the mixtures exceeded  $\frac{2}{3}$  (Fig. 6.6). In  $\text{NH}_4^+$ -N fed plants, a pH higher than 7.0 favors the reaction of  $\text{NH}_4^+$  with  $\text{HCO}_3^-$  to produce  $\text{NH}_3$ ,  $\text{H}_2\text{O}$ , and  $\text{CO}_2$  (Havlin et al., 1999; Marschner, 1995). A concentration of free  $\text{NH}_3$  higher than 0.06 mM has been reported detrimental for plant growth (Schenk and Wehrmann, 1979). In present experiment, after the addition of  $\text{HCO}_3^-$ , solution pH ranged between 8.11 and 8.37, what may have caused the production of toxic levels of  $\text{NH}_3$ . Decreased plant growth, assimilation and transpiration rate, and increased sap pH, are some of the responses of plants to an excessive concentration of  $\text{NH}_3$  (Schenk and Wehrmann, 1979).

Solution initial pH after adding  $\text{HCO}_3^-$  was between 8.11 to 8.37, but solution final pH was much lower in mixtures containing a high proportion of  $\text{NH}_4^+$  (Table 6.10). Nutrition exclusively with  $\text{NO}_3^-$ -N causes an increment in solution pH because  $\text{NO}_3^-$  uptake is coupled to the consumption of  $\text{H}^+$  (Mengel and Kirkby, 2001). On the other hand, the uptake of  $\text{NH}_4^+$  is correlated to an equimolar extrusion of  $\text{H}^+$  and acidification of the medium (Marschner, 1995). Thus the higher the  $\text{NH}_4^+$  proportion the greater the  $\text{NH}_4^+$  uptake and the greater the acidification of the nutrient solution.

Ammonium can also decrease solution pH by reacting with  $\text{HCO}_3^-$ . In this way, it causes a decrease in the buffer capacity and acidification in mixtures containing a small proportion of  $\text{NH}_4^+$  (Table 6.8 and 6.10). This would explain the improved plant growth in mixtures with a small proportion of  $\text{NH}_4^+$ .

The most favorable  $\text{NO}_3^-:\text{NH}_4^+$  ratio for the growth of sunflower in solutions containing 5 mM  $\text{NaHCO}_3$  was 0.75:0.25 (Fig. 5.6). In beans, it appears that the ratio at the  $1/3:1/3:1/3$  centroid point in present experiment (0.83:0.17  $\text{NO}_3^-:\text{NH}_4^+$  ratio) favored plant growth. This implies that also for beans some  $\text{NH}_4^+$  moderates the negative effect of  $\text{HCO}_3^-$ .

Increased N uptake in  $\text{NH}_4^+$ -N fed plants has been reported in many species. Increasing proportions of  $\text{NH}_4^+$  caused an increase in total N uptake in tomato (Flores et al., 2001), ageratum (Jeong and Lee, 1996), salvia (Jeong and Lee, 1996), and pecan (Kim et al., 2002). There is also evidence of antagonism between  $\text{NH}_4^+$  and  $\text{NO}_3^-$  in Douglas fir, in which the addition of  $\text{NH}_4^+$ -N to solutions containing varying concentration of  $\text{NO}_3^-$  resulted in decreased  $\text{NO}_3^-$  uptake (Kamminga-van Wijk and Prins, 1993). Additionally,  $\text{NH}_4^+$  uptake is enhanced over  $\text{NO}_3^-$  as solution pH increases from 4.5 to 6.0 in soybean plants (Vessey et al., 1990), or from 2.75 to 7.25 in arabica coffee plant (Vaast et al., 1998), suggesting that slightly alkaline pH is favorable for  $\text{NH}_4^+$  uptake.

*Na<sup>+</sup> Effect.* Shoot mass was increased in mixtures containing a low to intermediate proportion of  $\text{Na}^+$ , but at higher proportion,  $\text{Na}^+$  caused a decrease in shoot growth (Fig. 6.6). The decrease in growth by  $\text{Na}^+$  was not as large as that induced by  $\text{NH}_4^+$ . In natrophilic species,  $\text{Na}^+$  can promote plant growth by substituting  $\text{K}^+$  up to certain extent (Marschner, 1995). Bean is considered a natrophobic plant because of its susceptibility to  $\text{Na}^+$  (Hawker et al., 1974; Marschner, 1995). In addition to the natrophobic trait, bean is also a  $\text{Na}^+$  excluder (Sibole et al., 2000), implying that this species accumulate  $\text{Na}^+$  in the vacuoles of root cells, preventing its translocation to more sensitive organs, such as leaves. Results from this experiment confirm that mixtures containing 5 mM  $\text{Na}^+$  had a detrimental effect on growth but a low concentration of  $\text{Na}^+$ , combined with  $\text{K}^+$  and  $\text{NH}_4^+$ , had a beneficial effect (Fig. 6.6). The beneficial effect of  $\text{Na}^+$  may be due to the substitution of  $\text{K}^+$  by  $\text{Na}^+$  in some of the less specific functions, such as regulation of water potentials, leaving more  $\text{K}^+$  for the enzymatic activity

regulation in the new organs, as suggested for  $\text{Rb}^+$  in sugar beet (El-Sheikh and Ulrich, 1970).

*K<sup>+</sup> Effect.* Plant growth increased in mixtures containing a high proportion of  $\text{K}^+$  (Fig. 6.6). The growth promoting effect of  $\text{K}^+$  was more remarkable in blends containing low  $\text{Na}^+$  and moderate  $\text{NH}_4^+$ .

Binary blends of  $\text{K}^+:\text{Na}^+$  (Fig. 6.6) caused a severe decrease in growth, indicating an antagonistic relationship between  $\text{K}^+$  and  $\text{Na}^+$ . The apparent contradiction between the higher shoot mass at the  $\text{Na}^+$  pure blend, 0:0:1, and the lower shoot mass in the 0:<sup>1</sup>/<sub>2</sub>:<sup>1</sup>/<sub>2</sub> binary blend at which the proportion of  $\text{Na}^+$  is even lower, may be explained by the  $\text{NO}_3^-:\text{NH}_4^+$  ratio. In the  $\text{K}^+:\text{Na}^+$  binary blend, 0:<sup>1</sup>/<sub>2</sub>:<sup>1</sup>/<sub>2</sub>, the  $\text{NO}_3^-:\text{NH}_4^+$  ratio is 1:0, thus, bean plants were fed exclusively with  $\text{NO}_3^-$ -N. Growth of sunflower was also lower in plants fed with just  $\text{NO}_3^-$ -N (Fig. 5.6). Another explanation may be the direct antagonism of  $\text{Na}^+$  and  $\text{K}^+$ . An excess of  $\text{Na}^+$  can cause a deficiency of  $\text{K}^+$  and consequently a decreased plant growth (Haro et al., 1993). Since in the  $\text{Na}^+$  pure blend, 0:0:1, there was no  $\text{K}^+$ , it is possible that  $\text{K}^+$  was replaced at some extent by  $\text{Na}^+$ .

#### Root growth and total chlorophyll concentration

Root mass exhibited similar general trends as described for shoot growth parameters (Fig. 6.6). In relative terms, root mass was more affected than shoot mass in plants grown in mixtures containing  $\text{NH}_4^+$ . This was demonstrated by the higher shoot:root ratio (Table 6.10). This could have been caused by some degree of toxicity from the  $\text{NH}_3$  released in the nutrient solution, causing direct damage on root growth.

Total concentration of chlorophyll had a completely opposite response (Fig. 6.7), compared to shoot mass. The most conspicuous symptom in plants growing in high alkalinity conditions is a decrease in chlorophyll synthesis due to an alkalinity-induced Fe deficiency (Bertoni et al., 1992; Pearce et al., 1999a and b). Bean plants grown in solutions with only  $\text{Na}^+$ , 0:0:1 pure blend, exhibited a decrease in the synthesis of chlorophyll compared to plants growing with  $\text{K}^+$ , 0:1:0 pure blend (Table 6.10). The high  $\text{NH}_4^+$  blends, 1:0:0 mixture, induced an increase in the concentration of chlorophyll (Fig. 6.6)(Table 6.10). This may be explained by the severe decrease in leaf area (Fig.

6.7), which conduced to an increase in the concentration of chlorophyll per unit area. There are reports indicating that  $\text{NH}_4^+$  enhanced chlorophyll concentration by 21% in kohlrabi, although it was not correlated to an increase in the photosynthetic rate (Blanke et al., 1996).

### *Conclusions*

The relative proportion of  $\text{NH}_4^+$ ,  $\text{K}^+$ , and  $\text{Na}^+$  affected the intensity of the damage caused by 5 mM  $\text{HCO}_3^-$ . The models selected predicted the blend for maximum shoot mass to be 0.38:0.38:0.23  $\text{NH}_4^+:\text{K}^+:\text{Na}^+$ , and the blend with the minimum shoot mass to be 1:0:0. Thus, the toxicity caused by 5 mM  $\text{HCO}_3^-$ , was lowest in mixtures containing 38%  $\text{NH}_4^+$ , 38%  $\text{K}^+$ , and 23%  $\text{Na}^+$ . The  $\text{HCO}_3^-$  toxicity is highest in mixtures containing 100%  $\text{NH}_4^+$ .

A concentration of 5 mM  $\text{HCO}_3^-$  is a level of alkalinity that usually suppresses plant growth and induces a severe chlorosis. According to our results, the use of moderate levels of  $\text{NH}_4^+$  was associated to the best shoot growth rates, despite the concentration of  $\text{HCO}_3^-$  was high enough to inhibit plant growth. This suggests that  $\text{NH}_4^+$  can be used to partially mitigate the effect of  $\text{HCO}_3^-$  in irrigation water. However it is important to consider that a balanced  $\text{NO}_3^-:\text{NH}_4^+$  ratio is crucial to avoid  $\text{NH}_3$  toxicity.

### **Experiment 6.2. Effect of Mixtures of $\text{Na}^+$ , $\text{K}^+$ , and $\text{Cs}^+$ on the Response of Bean Plants to $\text{HCO}_3^-$**

In Experiment 6.1, the mixtures that contained high proportions of  $\text{NH}_4^+$  caused greatly decreased shoot and root growth. The  $\text{NH}_4^+$  pure blend decreased growth by 71% compared to the  $\text{K}^+$  pure blend. Plants with high  $\text{NH}_4^+$  proportions exhibited symptoms typical of specific  $\text{NH}_4^+$  toxicity, including stunted growth, severe decrease in leaf size, and intense green leaf color.

For this reason, this experiment was repeated substituting  $\text{NH}_4^+$  by  $\text{Cs}^+$ . However,  $\text{Cs}^+$  was significantly more toxic than  $\text{NH}_4^+$ . All plants exposed to any concentration of  $\text{Cs}^+$  died within 24 h. Thus, data were not collected and the experiment was terminated.

### Experiment 6.3. Effect of Mixtures of $\text{Rb}^+$ , $\text{K}^+$ , and $\text{Na}^+$ on the Response of Bean Plants to $\text{HCO}_3^-$

#### *Shoot and root mass*

0 mM  $\text{HCO}_3^-$

*Models.* Shoot and root mass were significantly affected by the  $\text{Rb}^+:\text{K}^+:\text{Na}^+$  treatments, according to ANOVA (Table 6.11). Shoot mass best fit to a linear model (Table 6.12). Root dry and fresh mass best fit a quadratic and special cubic model, respectively (Table 6.12). Plant response is demonstrated in response surface plots of Figs. 6.8 and 6.9.

*Pure Blends (Vertices).* The models showed that the highest shoot mass was obtained in the  $\text{K}^+$  pure blend (0:1:0 mixture), as indicated by the coefficient  $\beta_2$  (Table 6.12). The highest shoot mass in the  $\text{K}^+$  pure blend was followed by the  $\text{Na}^+$  ( $\beta_3$ ), and  $\text{Rb}^+$  ( $\beta_1$ ), pure blends (0:0:1 and 1:0:0 mixtures, respectively). Using the  $\text{K}^+$  pure blend as a reference point (0:1:0 mixture), shoot and root dry mass decreased by 19% and 12%, respectively, in the  $\text{Na}^+$  pure blend. The decrease in mass was 30% and 70% with the  $\text{Rb}^+$  pure blend.

The confidence intervals for the predicted shoot dry mass in the  $\text{K}^+$  and  $\text{Na}^+$  pure blends did not overlap with that for  $\text{Rb}^+$  (Table 6.13), indicating a significant difference between the predicted responses. Thus, the toxicity was ranked  $\text{Rb}^+ > \text{Na}^+ \approx \text{K}^+$ .

Root mass was affected by the counter-cation proportion in the mixtures. The decrease in root mass followed a similar tendency as shoot mass; the toxicity ranking was  $\text{Rb}^+ > \text{Na}^+ = \text{K}^+$  (Table 6.12, Fig. 6.9).

*Coordinates (0% to 100% Blends).* The  $\text{Rb}^+$  coordinate showed that increasing proportions resulted in decreased shoot and root dry mass, while the  $\text{Na}^+$  coordinate showed a slight decrease as the proportion of  $\text{Na}^+$  increased (Fig. 6.8 and 6.9). Maximum shoot mass gain was observed in the  $\text{K}^+$  coordinate (Fig. 6.8). Thus increasing proportions of  $\text{Rb}^+$  in the mixtures were toxic for plant growth.

Table 6.11. Effect of mixtures of varying proportions of Rb<sup>+</sup>, K<sup>+</sup>, and Na<sup>+</sup> counter-cations of HCO<sub>3</sub><sup>-</sup> on shoot, root, and leaf growth parameters of bean, *Phaseolus vulgaris* L. ‘Poncho’, plants grown in hydroponics with a 7.5 mM total concentration and two levels of HCO<sub>3</sub><sup>-</sup>. Experiment 6.3.

Mixtures Rb <sup>+</sup> :K <sup>+</sup> :Na <sup>+</sup>	Shoot Dry Mass <sup>z</sup> (g)		Shoot Fresh Mass (g)		Root Dry Mass (g)		Root Fresh Mass (g)		Leaf Dry Mass (g)		Leaf Fresh Mass (g)	
	HCO <sub>3</sub> <sup>-</sup> (mM)											
	0	7.5	0	7.5	0	7.5	0	7.5	0	7.5	0	7.5
Pure blends												
1:0:0	3.2b	2.7	15.9c	16.8	0.4e	0.7d	4.2c	6.2e	2.3d	1.8	11.4d	12.1
0:1:0	4.9a	2.8	27.2a	20.0	1.7ab	1.5ab	34.8ab	28.9ab	3.5a	1.9	19.9ab	14.7
0:0:1	4.1b	3.3	22.4abc	23.0	1.5ab	1.7abc	30.1ab	29.0bcd	2.6bd	2.4	14.4bcd	17.2
Binary blends												
<sup>1</sup> / <sub>2</sub> : <sup>1</sup> / <sub>2</sub> :0	4.7a	3.2	23.8ab	20.5	1.0bcde	1.2bcd	13.9c	15.5cde	3.2ab	2.2	16.9a-d	15.0
<sup>1</sup> / <sub>2</sub> :0: <sup>1</sup> / <sub>2</sub>	3.8b	3.2	17.6abc	18.2	0.6de	0.7d	4.9c	6.0e	2.6bcd	2.0	12.5cd	12.9
0: <sup>1</sup> / <sub>2</sub> : <sup>1</sup> / <sub>2</sub>	4.6ab	3.7	26.2a	28.3	1.7a	2.1a	37.2a	47.4a	3.1abc	2.5	17.7abc	20.2
Centroid												
<sup>1</sup> / <sub>3</sub> : <sup>1</sup> / <sub>3</sub> : <sup>1</sup> / <sub>3</sub>	4.7a	2.8	18.3bc	16.3	0.7cde	0.8dc	9.7c	12.3de	2.5cd	1.6	13.4cd	11.9
Tertiary blends												
<sup>2</sup> / <sub>3</sub> : <sup>1</sup> / <sub>6</sub> : <sup>1</sup> / <sub>6</sub>	4.9a	3.9	23.5abc	16.9	1.1abc	0.8d	8.3c	8.6e	3.2ab	1.9	17.0a-d	12.0
<sup>1</sup> / <sub>6</sub> : <sup>2</sup> / <sub>3</sub> : <sup>1</sup> / <sub>6</sub>	4.5ab	3.2	29.3a	26.0	1.6ab	1.8ab	27.6b	28.8abc	3.2ab	2.6	20.1a	18.0
<sup>1</sup> / <sub>6</sub> : <sup>1</sup> / <sub>6</sub> : <sup>2</sup> / <sub>3</sub>	3.5b	2.4	23.1ab	22.1	1.2a-d	1.3a-d	12.2c	18.3bcd	2.9a-d	2.0	15.9a-d	15.1
Significance <sup>y</sup>	***	NS	***	NS	***	***	***	***	***	NS	***	NS
R <sup>2</sup>	0.59	0.24	0.62	0.32	0.73	0.68	0.88	0.76	0.60	0.22	0.38	0.30
CV%	12.71	28.63	16.29	31.33	27.78	31.36	28.23	40.98	13.19	33.17	18.42	25.46

<sup>z</sup>Means within columns with the same letter indicates non significant difference at  $P \leq 0.05$  according to the LSD multiple comparison test

<sup>y</sup>Significance according to ANOVA, NS, \*, \*\*, \*\*\* non significant, significant at  $P \leq 0.05$ ,  $P \leq 0.01$  and  $P \leq 0.001$

R<sup>2</sup>= Coefficient of determination CV= Coefficient of variation



Table 6.12. Models<sup>z</sup> for the shoot, root, and leaf growth parameters of bean, *Phaseolus vulgaris* L. ‘Poncho’, plants in response to Rb<sup>+</sup>:K<sup>+</sup>:Na<sup>+</sup> mixtures with a 7.5 mM total concentration combined with two concentrations of HCO<sub>3</sub><sup>-</sup>. Experiment 6.3.

Coefficient <sup>y</sup>	Shoot Dry Mass (g)		Shoot Fresh Mass (g)		Root Dry Mass (g)		Root Fresh Mass (g)		Leaf Dr Mass (g)		Leaf Fresh Mass (g)	
	HCO <sub>3</sub> <sup>-</sup> (mM)											
	0	7.5	0	7.5	0	7.5	0	7.5	0	7.5	0	7.5
β <sub>1</sub>	+3.59	+2.66	+17.33	+14.87	+0.51	+0.68	+5.4	+7.6	+2.51	+1.72	+12.32	+10.62
β <sub>2</sub>	+5.13	+3.40	+28.29	+24.62	+1.68	+1.65	+35.7	+29.9	+3.54	+2.31	+20.92	+17.51
β <sub>3</sub>	+4.17	+3.39	+21.01	+23.43	+1.48	+1.69	+28.4	+27.6	+2.65	+2.29	+14.39	+16.80
β <sub>4</sub>	-	-	-	-	-0.04	-0.11	-19.1	-5.7	-	-	-	-
β <sub>5</sub>	-	-	-	-	-1.67	-2.53	-50.0	-47.5	-	-	-	-
β <sub>6</sub>	-	-	-	-	+0.38	+1.45	+16.2	+71.2	-	-	-	-
β <sub>7</sub>	-	-	-	-	-	-	-179.7	-276.2	-	-	-	-
Model	Linear		Linear		Quadratic		Special cubic		Linear		Linear	
Lack of fit <sup>x</sup>	P=0.082		P=0.236		P=0.032		P=0.113		P=0.257		P=0.537	
Adeq. Prec.	11.97		27.03		13.85		15.54		12.08		9.53	
R <sup>2</sup>	0.44		0.23		0.63		0.79		0.42		0.25	
CV%	21.02		27.03		31.78		36.76		22.76		26.72	

<sup>z</sup>To estimate any parameter, multiply the coefficients indicated in the table by the proportion of the corresponding counter-ion in the mixture of interest

<sup>y</sup>β<sub>1</sub>: Rb<sup>+</sup>, β<sub>2</sub>: K<sup>+</sup>, β<sub>3</sub>: Na<sup>+</sup>, β<sub>4</sub>: Rb<sup>+</sup>\*K<sup>+</sup>, β<sub>5</sub>: Rb<sup>+</sup>\*Na<sup>+</sup>, β<sub>6</sub>: K<sup>+</sup>\* Na<sup>+</sup>, β<sub>7</sub>: Rb<sup>+</sup>\* K<sup>+</sup>\*Na<sup>+</sup>

<sup>x</sup>Lack of fit according to ANOVA

Adeq. Prec.=Adequate precision

R<sup>2</sup>= Coefficient of determination

CV= Coefficient of variation

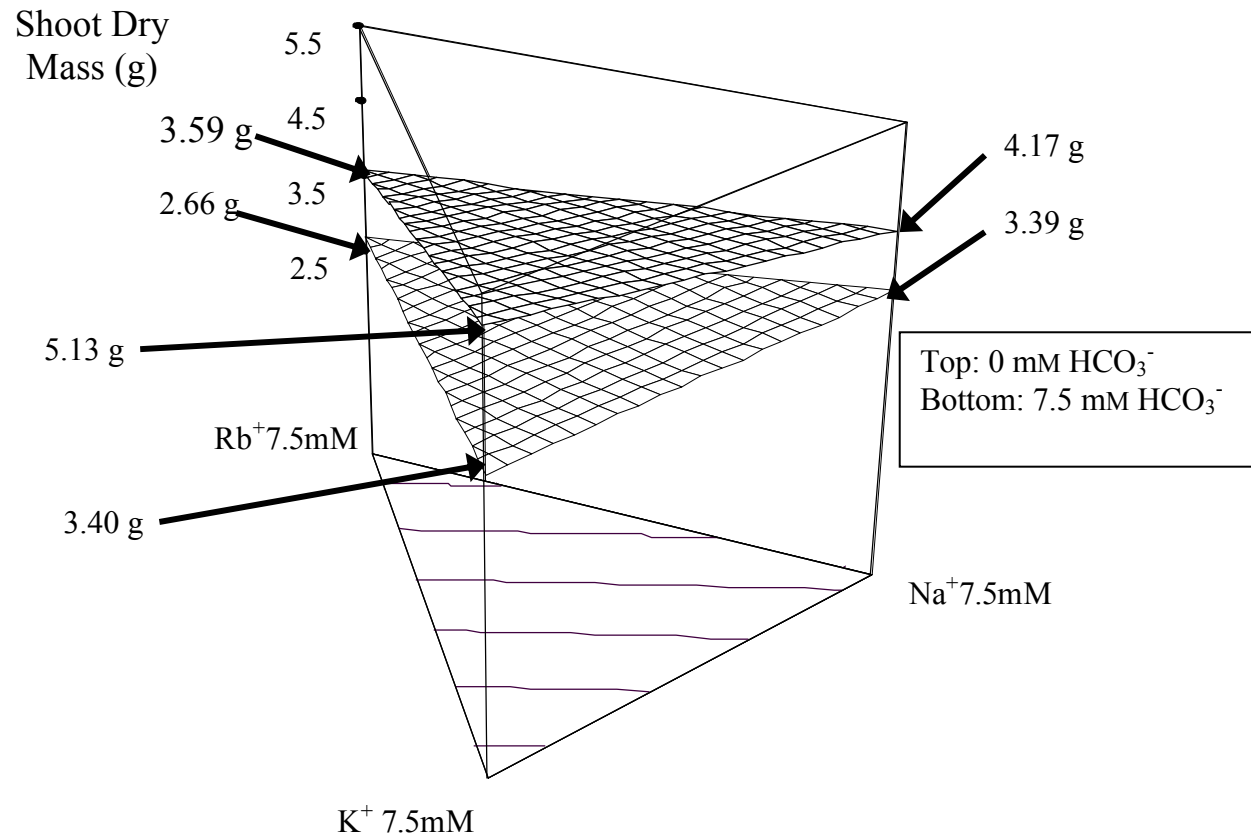

Fig. 6.8. Effect of mixtures of varying proportions of Rb<sup>+</sup>, K<sup>+</sup>, and Na<sup>+</sup> as counter-cations of HCO<sub>3</sub><sup>-</sup> on shoot dry mass of bean, *Phaseolus vulgaris* L. 'Poncho', grown in hydroponics with 7.5 mM total concentration and two levels of HCO<sub>3</sub><sup>-</sup>.

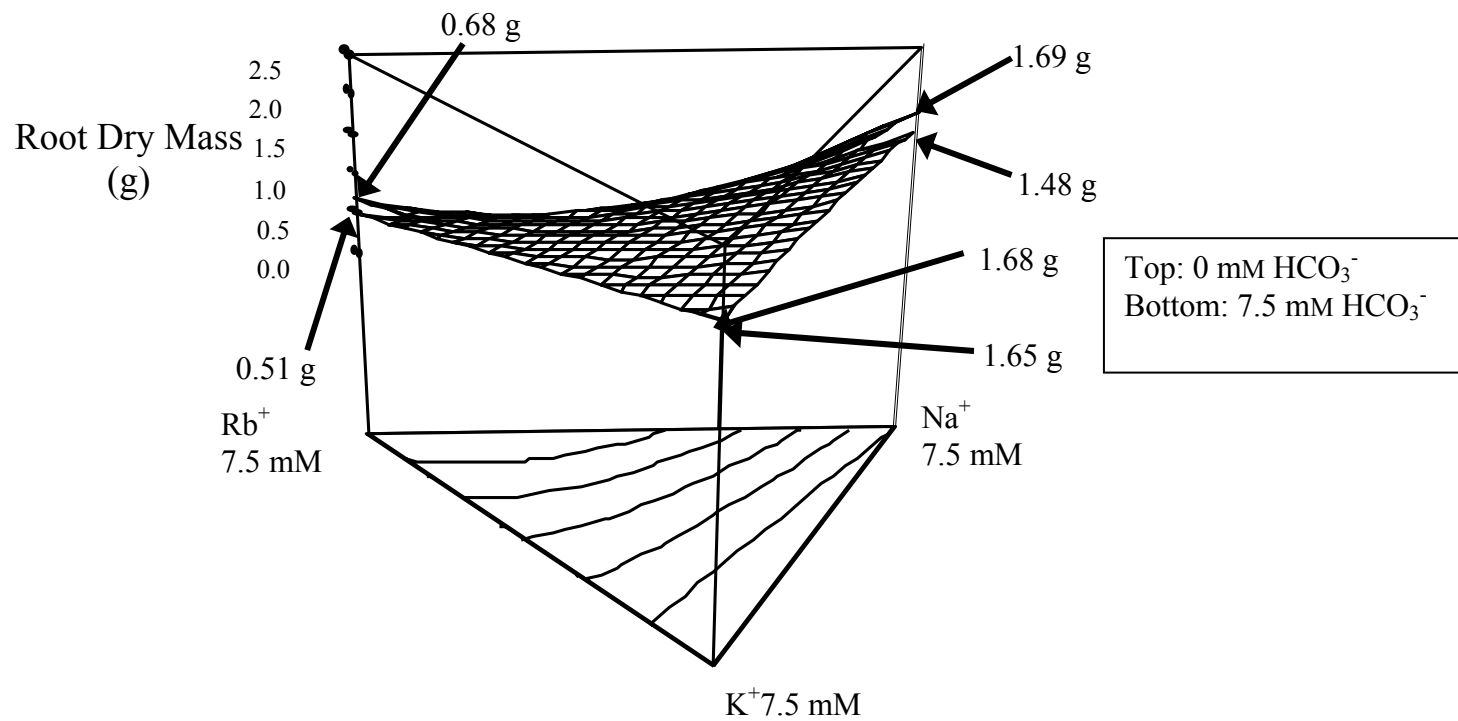

Fig. 6.9. Effect of mixtures of varying proportions of Rb<sup>+</sup>, K<sup>+</sup>, and Na<sup>+</sup> as counter-cations of HCO<sub>3</sub><sup>-</sup> on root dry mass of bean, *Phaseolus vulgaris* L. 'Poncho', grown in hydroponics with 7.5 mM total concentration and two levels of HCO<sub>3</sub><sup>-</sup>.

Table 6.13. Final equations for the growth parameters of bean, *Phaseolus vulgaris* L. ‘Poncho’, plants in response to Rb<sup>+</sup>:K<sup>+</sup>:Na<sup>+</sup> mixtures with a 7.5 mM total concentration combined with two concentrations of HCO<sub>3</sub><sup>-</sup>. Experiment 6.3.

Parameter	Final equation <sup>z</sup>
Shoot Dry Mass (g)	$3.13Rb + 4.27K + 3.78Na - 0.47Rb \cdot HCO_3^- - 0.86K \cdot HCO_3^- - 0.39Na \cdot HCO_3^-$
Shoot Fresh Mass (g)	$16.10Rb + 26.45K + 22.22Na - 1.23Rb \cdot HCO_3^- - 1.83K \cdot HCO_3^- + 1.21Na \cdot HCO_3^-$
Root Dry Mass (g)	$0.60Rb + 1.67K + 1.58Na - 0.07Rb \cdot K - 2.10Rb \cdot Na + 0.09Rb \cdot HCO_3^- + 0.91K \cdot Na - 0.02K \cdot HCO_3^- + 0.11 Na \cdot HCO_3^- - 0.04Rb \cdot K \cdot HCO_3^- - 0.43Rb \cdot Na \cdot HCO_3^- + 0.54 - 0.04K \cdot Na \cdot HCO_3^-$
Root Fresh Mass (g)	$6.50Rb + 32.8K + 27.98Na - 12.41Rb \cdot K - 48.71Rb \cdot Na + 1.12Rb \cdot HCO_3^- + 44.02K \cdot Na - 2.91K \cdot HCO_3^- - 0.41Na \cdot HCO_3^- - 227.95Rb \cdot K \cdot Na + 6.74Rb \cdot K \cdot HCO_3^- + 1.29Rb \cdot Na \cdot HCO_3^- + 27.81K \cdot Na \cdot HCO_3^- - 48.26Rb \cdot K \cdot Na \cdot HCO_3^-$
Leaf Dry Mass (g)	$2.11Rb + 2.92K + 2.47Na - 0.39Rb \cdot HCO_3^- - 0.61K \cdot HCO_3^- - 0.18Na \cdot HCO_3^-$
Leaf Fresh Mass (g)	$11.47Rb + 19.22K + 15.59Na - 0.85Rb \cdot HCO_3^- - 1.71K \cdot HCO_3^- + 1.205Na \cdot HCO_3^-$
Leaf Area (cm <sup>2</sup> )	$419.3Rb + 693.7K + 616.3Na - 89.4Rb \cdot HCO_3^- - 123.0K \cdot HCO_3^- - 20.6Na \cdot HCO_3^-$
Shoot:Root Ratio (g·g <sup>-1</sup> )	$5.92Rb + 2.55K + 2.39Na - 2.24Rb \cdot K + 6.43Rb \cdot Na - 1.84Rb \cdot HCO_3^- - 1.15K \cdot Na - 0.46K \cdot HCO_3^- - 0.53Na \cdot HCO_3^- + 0.80Rb \cdot K \cdot Na - 0.34Rb \cdot Na \cdot HCO_3^- - 0.05K \cdot Na \cdot HCO_3^-$
Solution pH	$6.36Rb + 7.32K + 7.11Na - 1.09Rb \cdot K - 2.09Rb \cdot Na + 1.90Rb \cdot HCO_3^- + 0.41K \cdot Na + 0.95K \cdot HCO_3^- + 1.10Na \cdot HCO_3^- - 0.78Rb \cdot K \cdot HCO_3^- + 2.05Rb \cdot Na \cdot HCO_3^- - 0.24K \cdot Na \cdot HCO_3^-$
Total Chlorophyll (µg·cm <sup>-2</sup> )	$3.50Rb + 5.56K + 5.87Na - 0.61Rb \cdot HCO_3^- - 0.11K \cdot HCO_3^- - 0.21Na \cdot HCO_3^-$
Water Consumption (ml·plant <sup>-1</sup> )	$855.8Rb + 1648.1K + 1529.8Na - 162.8Rb \cdot HCO_3^- - 219.6K \cdot HCO_3^- - 151.4Na \cdot HCO_3^-$

<sup>z</sup>To estimate the response, the counter-ions must be expressed in terms of their proportion in the mixture of interest and HCO<sub>3</sub><sup>-</sup> takes a -1 or +1 value at a concentration of 0 and 7.5 mM, respectively.

*Optimization.* The highest shoot mass predicted by the models was with the pure blend of  $K^+$  (0:1:0 mixture), while the lowest mass was with the  $Rb^+$  blend (1:0:0 mixture). The model predicted the best blend for shoot dry mass to be the 0:1:0 mixture, yielding 5.1 g. The most toxic blend was predicted to be the 1:0:0 mixture, yielding 3.59 g.

The highest root dry mass was predicted to occur in the 0:0.55:0.45 mixture, while the 0.74:0:0.26 mixture resulted in the lowest root mass.

7.5 mM  $HCO_3^-$

*Models.* The  $Rb^+ : K^+ : Na^+$  treatments did not affect significantly shoot mass of plants grown in solutions containing  $HCO_3^-$  according to ANOVA (Table 6.11), but root mass was significantly affected. The model for shoot dry and fresh mass best fit a linear equation (Table 6.12). Root dry mass response best fit a quadratic model, while fresh mass fit a special cubic model (Table 6.12). The response is demonstrated in the response surface plots of Fig. 6.9.

*Pure Blends (Vertices).* The highest shoot mass was obtained in the  $K^+$  and  $Na^+$  pure blends (0:1:0 and 0:0:1, respectively), as indicated by the coefficients  $\beta_2$  and  $\beta_3$ , respectively (Table 6.12). The lowest mass occurred with the  $Rb^+$  pure blend (1:0:0 mixture)(see coefficient  $\beta_1$  in Table 6.12). The confidence interval for the predicted shoot dry mass in the  $K^+$  and  $Na^+$  pure blends did not overlap with that for  $Rb^+$  (Table 6.14), indicating a significant difference between the predicted responses. Thus, toxicity was ranked  $Rb^+ > Na^+ = K^+$ . According to the models, shoot dry mass was decreased by 21% in the  $Rb^+$  pure blend compared to the  $K^+$  and  $Na^+$  pure blends (Table 6.12).

Root mass was unaffected by the concentration of  $HCO_3^-$ , as indicated by the slight difference in the response surfaces in Fig. 6.9. Root mass was affected by the counter-cation proportion in the mixtures. Decreased root mass followed a similar tendency as shoot mass; the toxicity ranking was  $Rb^+ > Na^+ = K^+$  (Table 6.12, Fig. 6.9). Root dry mass was decreased 60% by the  $Rb^+$  pure blend compared to the  $K^+$  and  $Na^+$  pure blends.

Table 6.14. Predicted response and 95% confidence interval for growth parameters evaluated of bean, *Phaseolus vulgaris* L. 'Poncho', plants grown in mixtures of varying proportions of Rb<sup>+</sup>, K<sup>+</sup>, and Na<sup>+</sup> counter-cations of HCO<sub>3</sub><sup>-</sup> with 7.5 mM total concentration and two concentrations of HCO<sub>3</sub><sup>-</sup>. Experiment 6.3.

Mixtures Rb <sup>+</sup> :K <sup>+</sup> :Na <sup>+</sup>	Shoot Dry Mass (g)			Root Dry Mass (g)			Solution pH			Total Chlorophyll (µg·cm <sup>-2</sup> )			Water Consumption (ml·plant <sup>1</sup> )		
	CI <sub>L</sub> <sup>z</sup>	CI <sub>H</sub> <sup>y</sup>	CI <sub>L</sub>	CI <sub>H</sub>	CI <sub>L</sub>	CI <sub>H</sub>	CI <sub>L</sub>	CI <sub>H</sub>	CI <sub>L</sub>	CI <sub>H</sub>	CI <sub>L</sub>	CI <sub>H</sub>	CI <sub>L</sub>	CI <sub>H</sub>	
0 mM HCO <sub>3</sub> <sup>-</sup>															
1 0 0	3.07	3.59	4.12	0.35	0.59	0.82	3.51	3.89	4.28	3.40	4.11	4.82	806	1019	1231
0 1 0	4.57	5.13	5.69	1.41	1.67	1.94	5.87	6.29	6.70	4.91	5.67	6.43	1641	1868	2094
0 0 1	3.64	4.17	4.70	1.33	1.57	1.81	5.30	5.69	6.08	5.35	6.07	6.79	1468	1682	1895
7.5 mM HCO <sub>3</sub> <sup>-</sup>															
1 0 0	2.10	2.66	3.22	0.35	0.59	0.82	7.82	8.23	8.64	2.14	2.90	3.65	468	693	918
0 1 0	2.81	3.40	4.00	1.41	1.57	1.94	7.81	8.25	8.69	4.63	5.44	6.25	1187	1429	1670
0 0 1	2.82	3.39	3.96	1.33	1.57	1.88	7.81	8.23	8.65	4.89	5.66	6.43	1149	1378	1608

<sup>z</sup>CI<sub>L</sub>=low confidence interval

<sup>y</sup>CI<sub>H</sub>=high confidence interval

*Coordinates (0% to 100% Blends).* The response surface showed non-significant effect on the  $K^+$  and  $Na^+$  coordinates, but the  $Rb^+$  coordinate indicated a severe decrease with increasing proportions of  $Rb^+$  (Fig. 6.8 and 6.9).

*Optimization.* The highest shoot mass was predicted to occur at the  $K^+$  (0:1:0) mixture, yielding 3.4 g, and the 0:0.44:0.46  $Rb^+ : K^+ : Na^+$  mixture. The most toxic mixture was 1:0:0, yielding 2.66 g.

*General Effect of  $HCO_3^-$ .* Shoot mass decreased in mixtures containing  $HCO_3^-$  as indicated by the lower response surface plots for the 7.5 mM  $HCO_3^-$  (Table 6.12)(Fig. 6.8) compared to 0 mM  $HCO_3^-$ . The detrimental effect of  $HCO_3^-$  was more obvious in the  $K^+$  pure blend (Fig. 6.8). At the  $K^+$  vertex, the addition of 7.5 mM  $HCO_3^-$  caused a 34% decrease in shoot mass, while in the  $Rb^+$  and  $Na^+$  vertices, the decrease was 26% and 19%, respectively (Table 6.12).

The detrimental effect of  $HCO_3^-$  was also quantitatively determined in the final models by the antagonistic effect (negative coefficients) that all the counter-cations showed when they interacted with  $HCO_3^-$  (Table 6.13).

#### *Leaf growth*

The  $Rb^+ : K^+ : Na^+$  treatments affected significantly leaf dry and fresh mass (Table 6.11) and leaf area (Table 6.15), at both levels of  $HCO_3^-$ , according to ANOVA.

The models for leaf growth parameters are shown in Table 6.12 and 6.16. The response surface for leaf dry mass and leaf area is shown in Fig. 6.10 and 6.11. The best fit model, the effect of pure blends and coordinates, and the optimum mixture, were very similar to the shoot mass response.

#### *Shoot:root ratio*

According to ANOVA, the  $Rb^+ : K^+ : Na^+$  treatments affected significantly ( $P \leq 0.05$ ) the shoot:root ratio (Table 6.15) at both levels of  $HCO_3^-$ . A quadratic model best fit the response to the  $Rb^+ : K^+ : Na^+$  mixtures (Table 6.16).

In general,  $HCO_3^-$  decreased the shoot:root ratio (Table 6.16). The detrimental effect of  $HCO_3^-$  was more obvious in the  $Rb^+$  pure blends ( $\beta_1$ )(Table 6.16).

Table 6.15. Effect of mixtures of varying proportions of Rb<sup>+</sup>, K<sup>+</sup>, and Na<sup>+</sup> counter-cations of HCO<sub>3</sub><sup>-</sup> on leaf area, shoot:root ratio, solution pH, total chlorophyll concentration, and water consumption of bean, *Phaseolus vulgaris* L. 'Poncho', plants grown in hydroponics with a 7.5 mM total concentration and two levels of HCO<sub>3</sub><sup>-</sup>. Experiment 6.3.

Mixtures Rb <sup>+</sup> :K <sup>+</sup> :Na <sup>+</sup>	Leaf Area <sup>z</sup> (cm <sup>2</sup> )		Shoot:Root Ratio (g:g <sup>-1</sup> )		Solution pH		Total Chlorophyll (µg·cm <sup>-2</sup> )		Water Consumption (ml·plant <sup>-1</sup> )	
	HCO <sub>3</sub> <sup>-</sup> (mM)									
	0	7.5	0	7.5	0	7.5	0	7.5	0	7.5
Pure blends										
1:0:0	460c	384a	7.9a	4.2ab	3.91e	8.23	0.18c	0.37c	1067c	802e
0:1:0	755ab	470a	3.1de	1.9def	6.29a	8.23	5.47a	4.24b	1811a	1201cde
0:0:1	646bc	630a	2.8e	1.9def	6.31a	8.25	4.29ab	4.05a	1793a	1368abc
Binary blends										
<sup>1</sup> / <sub>2</sub> : <sup>1</sup> / <sub>2</sub> :0	654c	478a	4.9cd	2.8cd	5.12bc	8.17	1.12c	1.48bc	1443abc	998cde
<sup>1</sup> / <sub>2</sub> :0: <sup>1</sup> / <sub>2</sub>	540bc	432a	7.1ab	4.7a	4.31de	8.30	0.25c	0.31c	1128bc	881de
0: <sup>1</sup> / <sub>2</sub> : <sup>1</sup> / <sub>2</sub>	681ab	647a	2.7e	1.7ef	6.44a	8.34	5.79a	9.04a	1856a	1734a
Centroid										
<sup>1</sup> / <sub>3</sub> : <sup>1</sup> / <sub>3</sub> : <sup>1</sup> / <sub>3</sub>	536bc	376a	4.9bcd	3.0cde	4.48cde	8.16	0.69c	1.06c	1237bc	855de
Tertiary blends										
<sup>2</sup> / <sub>3</sub> : <sup>1</sup> / <sub>6</sub> : <sup>1</sup> / <sub>6</sub>	725ab	388a	6.0abc	3.5bc	4.85cd	8.31	0.57c	0.61c	1496ab	1014cde
<sup>1</sup> / <sub>6</sub> : <sup>2</sup> / <sub>3</sub> : <sup>1</sup> / <sub>6</sub>	884a	633a	3.2de	2.6cdef	6.05ab	8.31	3.61b	4.39b	1829a	1472a
<sup>1</sup> / <sub>6</sub> : <sup>1</sup> / <sub>6</sub> : <sup>2</sup> / <sub>3</sub>	680abc	517a	4.7cde	2.5def	5.30bc	8.10	1.03c	1.92bc	1496ab	1245bc
Significance <sup>y</sup>	***	***	***	***	***	NS	***	***	**	**
R <sup>2</sup>	0.61	0.32	0.78	0.80	0.73	0.34	0.84	0.69	0.55	0.54
CV%	16.25	34.93	22.29	18.98	11.74	1.45	46.74	74.79	19.63	26.47

<sup>z</sup>Means within columns with the same letter indicates non significant difference at  $P \leq 0.05$  according to the LSD multiple comparison test

<sup>y</sup>Significance according to ANOVA, NS, \*, \*\*, \*\*\* non significant, significant at  $P \leq 0.05$ ,  $P \leq 0.01$  and  $P \leq 0.001$

R<sup>2</sup> = Coefficient of determination

CV = Coefficient of variation



Table 6.16. Models<sup>z</sup> for leaf area, shoot:root ratio, solution pH, total chlorophyll concentration, and water consumption of bean, *Phaseolus vulgaris* L. ‘Poncho’, plants in response to Rb<sup>+</sup>:K<sup>+</sup>:Na<sup>+</sup> mixtures with a 7.5 mM total concentration combined with two concentrations of HCO<sub>3</sub><sup>-</sup>. Experiment 6.3.

Coefficient <sup>y</sup>	Leaf Area (cm <sup>2</sup> )		Shoot:Root Ratio (g·g <sup>-1</sup> )		Solution pH		Total Chlorophyll (µg·cm <sup>-2</sup> )		Water Consumption (ml·plant <sup>-1</sup> )	
	HCO <sub>3</sub> <sup>-</sup> (mM)									
	0	7.5	0	7.5	0	7.5	0	7.5	0	7.5
β <sub>1</sub>	+508.7	+330.0	+7.76	+4.08	+4.46	+8.23	+4.11	+2.90	+1018.6	+692.9
β <sub>2</sub>	+816.7	+570.8	+3.00	+2.09	+6.37	+8.25	+5.67	+5.44	+1867.7	+1428.5
β <sub>3</sub>	+636.9	+595.7	+2.92	+1.87	+6.01	+8.23	+6.07	+5.66	+1681.1	+1378.4
β <sub>4</sub>	-	-	-3.04	-1.43	-1.87	-0.31	-	-	-	-
β <sub>5</sub>	-	-	+6.76	+6.09	-4.14	-0.04	-	-	-	-
β <sub>6</sub>	-	-	-1.09	-1.20	+0.65	+0.17	-	-	-	-
β <sub>7</sub>	-	-	-	-	-	-	-	-	-	-
Model	Linear		Quadratic		Quadratic		Linear		Linear	
Lack of fit <sup>x</sup>	P=0.096		P=0.524		P=0.311		P=0.246		P=0.031	
Adeq. Prec.	12.31		19.00		20.28		11.37		14.13	
R <sup>2</sup>	0.38		0.82		0.91		0.37		0.48	
CV%	26.10		21.97		8.02		21.36		23.56	

<sup>z</sup>To estimate any parameter, multiply the coefficients indicated in the table by the proportion of the corresponding counter-ion in the mixture of interest

<sup>y</sup>β<sub>1</sub>: Rb<sup>+</sup>, β<sub>2</sub>: K<sup>+</sup>, β<sub>3</sub>: Na<sup>+</sup>, β<sub>4</sub>: Rb<sup>+</sup>\*K<sup>+</sup>, β<sub>5</sub>: Rb<sup>+</sup>\*Na<sup>+</sup>, β<sub>6</sub>: K<sup>+</sup>\* Na<sup>+</sup>, β<sub>7</sub>: Rb<sup>+</sup>\* K<sup>+</sup>\*Na<sup>+</sup>

<sup>x</sup>Lack of fit according to ANOVA

Adeq. Prec.=Adequate precision

R<sup>2</sup>= Coefficient of determination

CV= Coefficient of variation

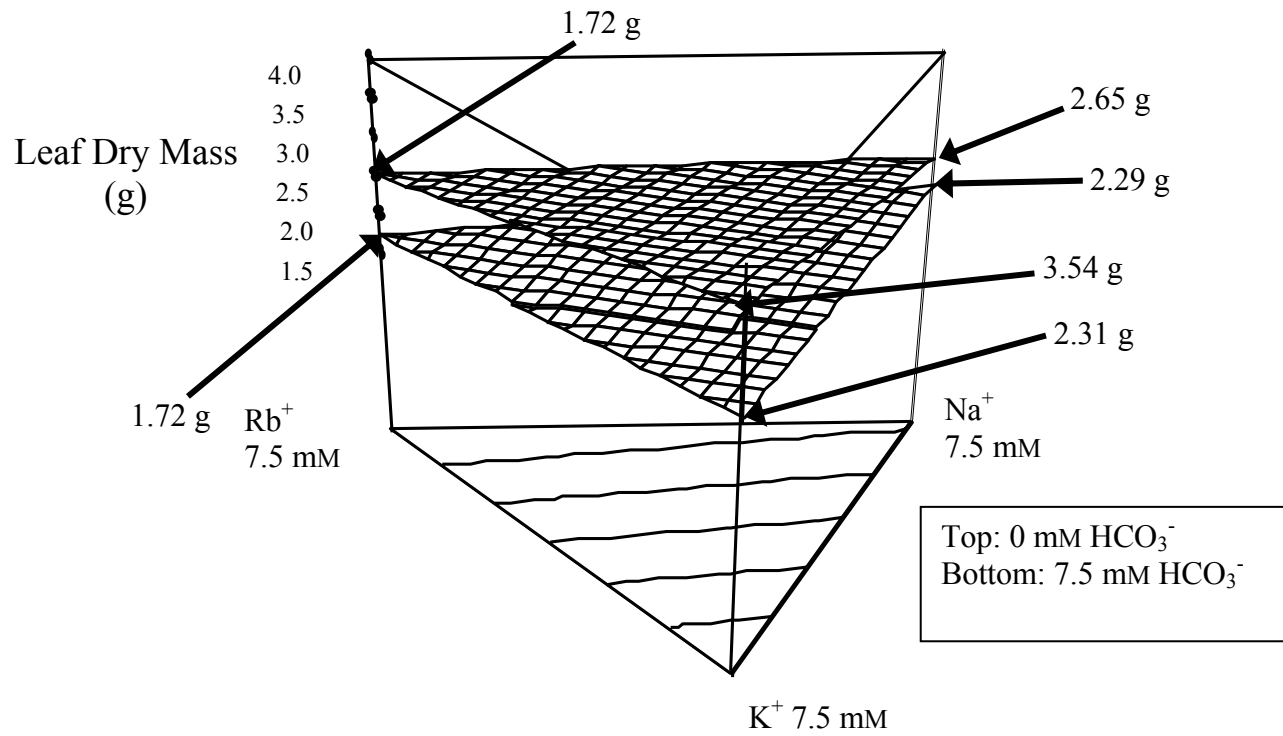

Fig. 6.10. Effect of mixtures of varying proportions of Rb<sup>+</sup>, K<sup>+</sup>, and Na<sup>+</sup> as counter-cations of HCO<sub>3</sub><sup>-</sup> on leaf dry mass of bean, *Phaseolus vulgaris* L. 'Poncho', grown in hydroponics with 7.5 mM total concentration and two levels of HCO<sub>3</sub><sup>-</sup>.

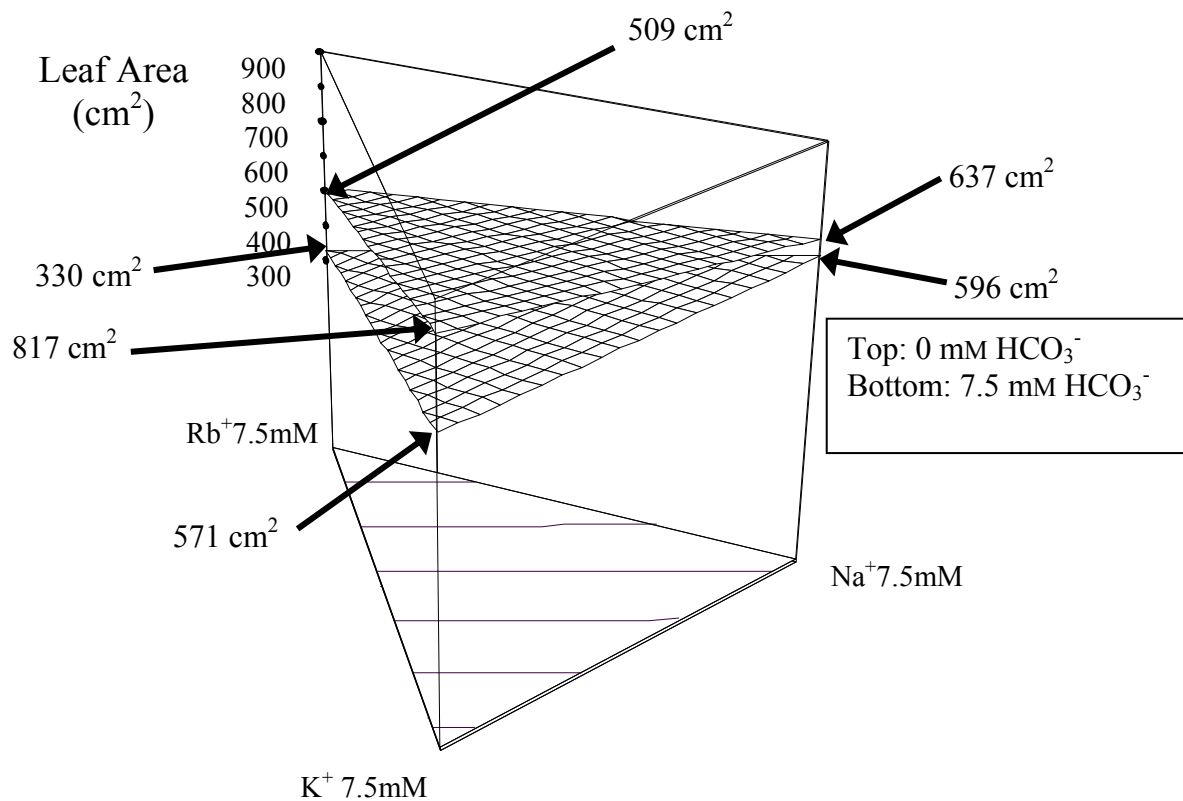

Fig. 6.11. Effect of mixtures of varying proportions of Rb<sup>+</sup>, K<sup>+</sup>, and Na<sup>+</sup> as counter-cations of HCO<sub>3</sub><sup>-</sup> on leaf area of bean, *Phaseolus vulgaris* L. 'Poncho', grown in hydroponics with 7.5 mM total concentration and two levels of HCO<sub>3</sub><sup>-</sup>.

The coefficients for the pure blends indicated that the largest ratio was obtained with the  $\text{Rb}^+$  pure blend (1:0:0 mixture),  $\beta_1$  (Table 6.16). The binary blends  $\text{Rb}^+:\text{K}^+$  and  $\text{K}^+:\text{Na}^+$  exhibited an antagonistic effect on the shoot:root ratio, contrary to the response exhibited by the  $\text{K}^+:\text{Na}^+$  binary blend (Table 6.16).

#### *Total chlorophyll*

The  $\text{Rb}^+:\text{K}^+:\text{Na}^+$  treatments affected significantly ( $P \leq 0.05$ ) total chlorophyll concentration at both levels of  $\text{HCO}_3^-$ , based on ANOVA (Table 6.15). The effect of the mixtures best fit a linear model (Table 6.16).

In general,  $\text{HCO}_3^-$  had a small effect on the decrease in chlorophyll concentration as demonstrated in Fig. 6.12. The final equation supports this fact since the coefficients for the interaction of each individual counter-cation with the level of  $\text{HCO}_3^-$  were very low (Table 6.13).

The major loss of chlorophyll due to the addition of  $\text{HCO}_3^-$  was observed in the  $\text{Rb}^+$  pure blend (Table 6.16)(Fig. 6.12). At any concentration of  $\text{HCO}_3^-$ , chlorophyll concentration was significantly ( $P \leq 0.05$ ) decreased in the  $\text{Rb}^+$  pure blend, in comparison to the  $\text{K}^+$  and  $\text{Na}^+$  mixtures, as deduced by the non overlapping confidence intervals (Table 6.14). This implies that the toxicity ranking was  $\text{Rb}^+ > \text{K}^+ > \text{Na}^+$  at both levels of  $\text{HCO}_3^-$ .

#### *Solution final pH*

According to ANOVA, the  $\text{Rb}^+:\text{K}^+:\text{Na}^+$  treatments significantly affected ( $P \leq 0.05$ ) solution final pH (Table 6.15) at 0 mM  $\text{HCO}_3^-$ . The addition of 7.5 mM  $\text{HCO}_3^-$  increased solution pH, but there was not a significant mixture effect ( $P > 0.05$ )(Table 6.16). Solution final pH best fit a quadratic model in response to the  $\text{Rb}^+:\text{K}^+:\text{Na}^+$  mixtures (Table 6.16).

In general, the addition of  $\text{HCO}_3^-$  to the solutions was associated to increased pH (Table 6.16). This is corroborated by the positive coefficients of the interactions of each individual counter-cation with the concentration of  $\text{HCO}_3^-$  in the final equation (Table 6.13).

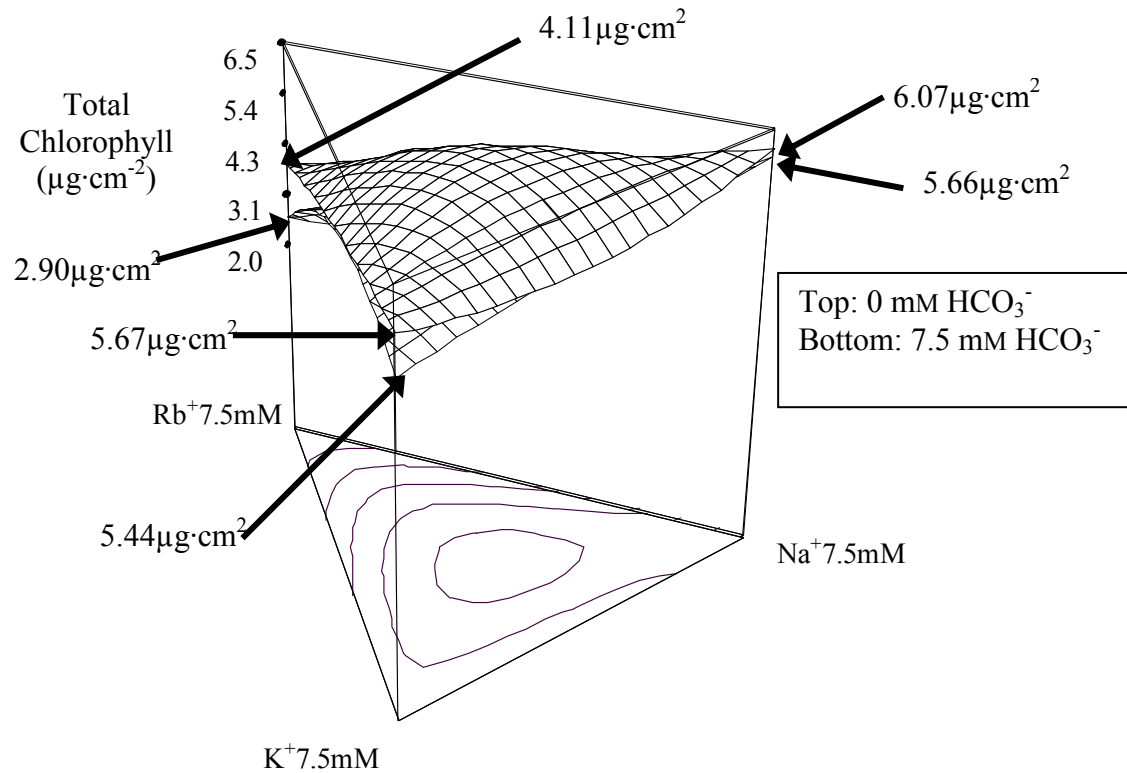

Fig. 6.12. Effect of mixtures of varying proportions of  $\text{Rb}^+$ ,  $\text{K}^+$ , and  $\text{Na}^+$  as counter-cations of  $\text{HCO}_3^-$  on total chlorophyll concentration of bean, *Phaseolus vulgaris* L. 'Poncho', grown in hydroponics with 7.5 mM total concentration and two levels of  $\text{HCO}_3^-$ .

The coefficients for the  $\text{Rb}^+$  ( $\beta_1$ ),  $\text{K}^+$  ( $\beta_2$ ), and  $\text{Na}^+$  ( $\beta_3$ ) pure blends were very similar in mixtures containing 7.5 mM  $\text{HCO}_3^-$ , but pH was remarkably decreased in the  $\text{Rb}^+$  ( $\beta_1$ ) pure blend in mixtures with no  $\text{HCO}_3^-$  added (Table 6.16). Both facts were supported by the non overlapping confidence intervals between the  $\text{Rb}^+$  and  $\text{K}^+$  pure blends and between the  $\text{Rb}^+$  and  $\text{Na}^+$  pure blends (Table 6.14). Thus, the effect of the mixtures on solution final pH ranking was (low to high):  $\text{K}^+ > \text{Na}^+ > \text{Rb}^+$  and  $\text{K}^+ \approx \text{Na}^+ = \text{Rb}^+$ , for solutions with 0 and 7.5 mM  $\text{HCO}_3^-$ , respectively.

#### *Water consumption*

Water uptake was affected significantly ( $P \leq 0.05$ ) by the  $\text{Rb}^+:\text{K}^+:\text{Na}^+$  treatments at both concentrations of  $\text{HCO}_3^-$  (Table 6.15). The effect of the mixtures on this parameter best fit to a linear model (Table 6.16).

In general,  $\text{HCO}_3^-$  had a strong effect in reducing water uptake as demonstrated in Fig. 6.13. The final equation supported this fact since the coefficients for the interaction of each individual counter-cation with the concentration of  $\text{HCO}_3^-$  were between 151 to 219 ml (Table 6.13).

The coefficients for the  $\text{K}^+$  and  $\text{Na}^+$  pure blends,  $\beta_3$ , and  $\beta_2$ , respectively, did not show a significant difference, hence there was no difference in water uptake at both concentrations  $\text{HCO}_3^-$  (Table 6.16).

According to the coordinates, bean plants showed reduced water consumption as the proportion of  $\text{Rb}^+$  increased, irrespective of the concentration of  $\text{HCO}_3^-$  (Fig 6.12). Increasing proportions of  $\text{K}^+$  and  $\text{Na}^+$  were associated to an increase in water consumption (Fig. 6.13).

#### *$\text{K}^+$ tissue concentration*

Potassium concentration was higher in plants grown in the 0:1:0  $\text{Rb}^+:\text{K}^+:\text{Na}^+$  pure blends, compared to the 1:0:0 and 0:0:1 mixtures (Fig. 6.14). This response was observed in both 0 and 7.5 mM  $\text{HCO}_3^-$ . Most of the  $\text{K}^+$  was concentrated on the roots and leaves, while the stems contained the lowest concentration. Comparing both concentrations of  $\text{HCO}_3^-$ , plants in 7.5 mM exhibited a lower concentration of  $\text{K}^+$  at correspondent mixtures containing no  $\text{HCO}_3^-$  (Fig. 6.14).

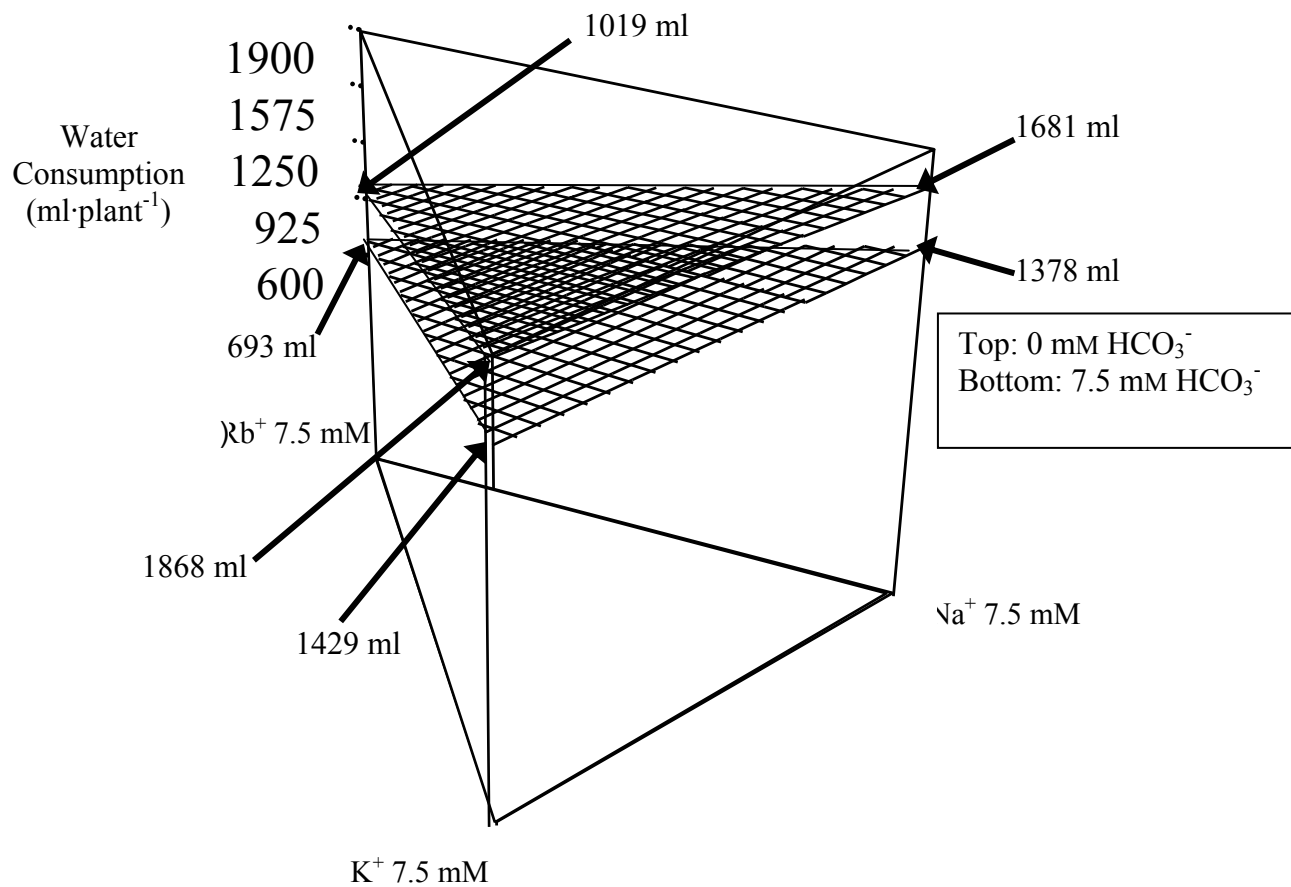

Fig. 6.13. Effect of mixtures of varying proportions of Rb<sup>+</sup>, K<sup>+</sup>, and Na<sup>+</sup> as counter-cations of HCO<sub>3</sub><sup>-</sup> on water consumption of bean, *Phaseolus vulgaris* L. 'Poncho', grown in hydroponics with 7.5 mM total concentration and two levels of HCO<sub>3</sub><sup>-</sup>.

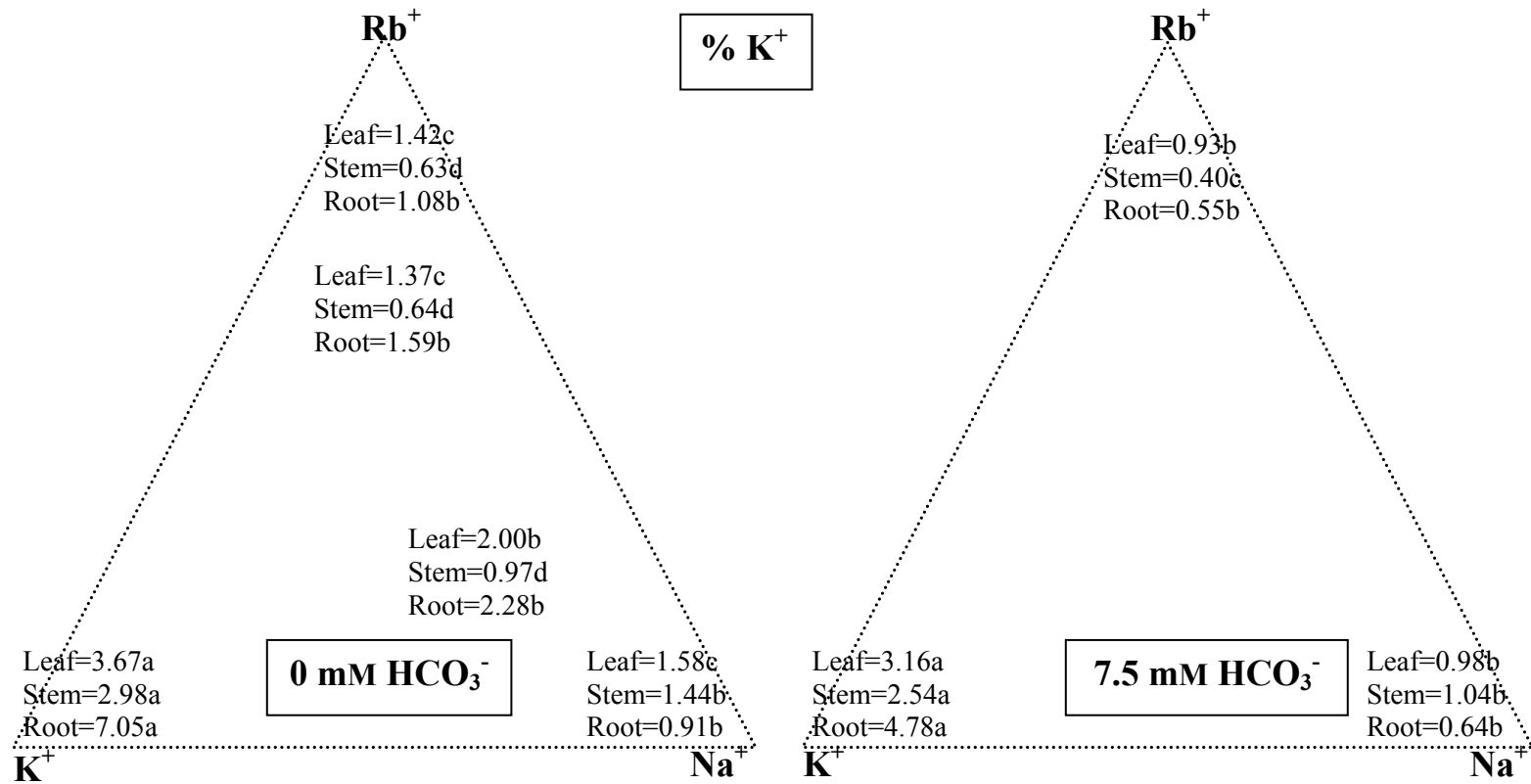

Fig. 6.14. Effect of mixtures of varying proportions of Rb<sup>+</sup>, K<sup>+</sup>, and Na<sup>+</sup> as counter-cations of HCO<sub>3</sub><sup>-</sup> on K<sup>+</sup> concentration of leaf, stem, and root tissue of bean, *Phaseolus vulgaris* L. ‘Poncho’, grown in hydroponics with 7.5 mM total concentration and two levels of HCO<sub>3</sub><sup>-</sup>. Within each plant organ, means with same letters indicate non significant difference according to LSD multiple comparison test.



The  $2/3:1/6:1/6$  and  $1/6:1/6:2/3$  mixture solutions contained low  $K^+$ , yet leaf tissue  $K^+$  was accumulated at adequate concentrations, 1.37% and 2.00%, respectively.

#### *Discussion*

The proportion of  $Rb^+$ ,  $K^+$ , and  $Na^+$  modified the response of bean plants to  $HCO_3^-$  (Table 6.12). Shoot dry mass represented the typical response surface to the mixtures (Fig. 6.8).

In general, plants responded to the toxicity of mixtures in the following rank (Fig. 6.7):

0 mM  $HCO_3^-$  (low to high growth; high to low toxicity):

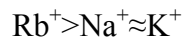

7.5 mM  $HCO_3^-$  (low to high growth; high to low toxicity):



Due to the design of the experiment, the  $Rb^+$  and  $Na^+$  pure blends (1:0:0 and 0:0:1, respectively) did not receive any  $K^+$  during the 6 days the treatments were imposed, but received  $K^+$  at the 7<sup>th</sup> day. The plants did not exhibit deficiency symptoms in any mixture. In order to eliminate the possibility of a hidden  $K^+$  deficiency, a  $K^+$  tissue analysis was performed on leaves, stems, and roots.

The concentration of  $K^+$  was significantly lower in plants grown in mixtures at the  $Rb^+$  and  $Na^+$  vertices, which contained no  $K^+$  (Fig. 6.14). Plants grown in mixtures containing at least proportions of  $1/6$  of  $K^+$ , were able to accumulate 2.00% leaf concentration of  $K^+$ , the minimum for adequate plant growth (Marschner, 1995). At higher proportions of  $K^+$  in the mixtures, the concentration of the nutrient in leaf tissues might be closer to the optimal. For this reason we conclude that the low concentration of  $K^+$  in some mixtures was not a detrimental on plant growth as long as the proportion of  $K^+$  was higher than  $1/6$ .

The maintenance of adequate leaf concentrations of  $K^+$  in spite of the low proportion of the nutrient in the mixtures may be due to the high affinity system for  $K^+$  uptake when plants are under limited  $K^+$  (Benlloc et al., 1989), as reported in sunflower (Benlloc et al., 1989) and other plants (Haro et al., 1993). Such a system enables the

plant to uptake  $K^+$  at a higher rate, in order to meet plant requirements. The appearance of the high affinity system occurs when the plants are cultivated in solutions containing 20  $\mu M$  of  $K^+$  or less (Benlloc et al., 1989), which is much lower than the  $K^+$  supplemented once weekly in present experiment. Another possibility is that the preculture for one week in a modified Hoagland's solution containing 1.5 mM  $K^+$  and extra  $K^+$  supplied at 0.5 mM every 7<sup>th</sup> day, might have satisfied plant's  $K^+$  requirements.

*Rb<sup>+</sup> Effect.* Pure blends of  $Rb^+$ , 1:0:0, caused a decrease in shoot growth irrespective of the levels of  $HCO_3^-$  (Fig. 6.8). In some plants species, such as sugar beet,  $Rb^+$  is recognized as beneficial (El-Sheikh, et al., 1967) but other reports indicate that it may be toxic at concentrations above 1 mM (El-Sheikh and Ulrich, 1970). The supply of  $Rb^+$  must be at intervals to avoid accumulation in plant tissues that may retard growth (Hara et al., 1977). In present experiment, the concentration of  $Rb^+$  used was up to 7.5 mM, which apparently was a very toxic concentration.

*K<sup>+</sup> Effect.* Plant growth increased in mixtures containing a high proportion of  $K^+$  and no  $HCO_3^-$  (Fig 6.7). In plants grown in mixtures containing 7.5 mM  $HCO_3^-$  the promoting effect of  $K^+$  disappeared, indicating a severe growth depression under conditions of alkalinity.

*Na<sup>+</sup> Effect.* Sodium pure blends, 0:0:1, caused a decrease in shoot growth in mixtures containing 0 mM  $HCO_3^-$  (Fig. 6.8). This was due to the natrophobic behavior of bean plants that makes this plant susceptible to elevated concentrations of  $Na^+$  (Hawker et al., 1974, Marschner, 1995). Results from this experiment confirm that mixtures containing 7.5 mM  $Na^+$  had a detrimental effect on growth. In mixtures containing 7.5 mM  $HCO_3^-$  (Fig. 6.8), increasing proportions of  $Na^+$  did not cause further decrease in plant growth.

The slightly detrimental effect of  $Na^+$  in bean plants grown at 5 mM  $HCO_3^-$  observed in Experiment 6.1 (0:0:1 mixture)(Fig. 6.6), was not detected in the present experiment (0:0:1 mixture) with 7.5 mM  $HCO_3^-$  (Fig. 6.8). Possibly the higher concentration of  $HCO_3^-$ , 7.5 mM, caused the loss of response to  $Na^+$ .

Another difference between the  $\text{NH}_4^+:\text{K}^+:\text{Na}^+$  and  $\text{Rb}^+:\text{K}^+:\text{Na}^+$  experiments (Experiment 6.1 and 6.3, respectively), was that the antagonistic effect of the  $\text{K}^+:\text{Na}^+$  binary blend,  $0:1/2:1/2$ , in the  $\text{NH}_4^+:\text{K}^+:\text{Na}^+$  experiment, disappeared in the  $\text{Rb}^+:\text{K}^+:\text{Na}^+$  experiment (Fig 6.5 and 6.7). In the  $\text{NH}_4^+:\text{K}^+:\text{Na}^+$  experiment, the  $\text{K}^+:\text{Na}^+$  binary blend contained a 0:1  $\text{NO}_3^-:\text{NH}_4^+$  ratio, whereas in the  $\text{Rb}^+:\text{K}^+:\text{Na}^+$  experiment the  $\text{NO}_3^-:\text{NH}_4^+$  ratio was maintained at 0.90:0.10. This suggested that the antagonistic response to the blend  $\text{K}^+:\text{Na}^+$  was due exclusively to the  $\text{NO}_3^-$ -N nutrition, not to the  $\text{K}^+:\text{Na}^+$  blend in the  $\text{NH}_4^+:\text{K}^+:\text{Na}^+$  experiment.

Root mass increased in mixtures high in  $\text{Na}^+$  when plants were treated with  $\text{HCO}_3^-$  (Table 6.12)(Fig. 6.9). It is possible that increasing root growth is a mechanism to dilute the  $\text{Na}^+$  that is accumulating, so its negative effect is reduced (Sibole, et al., 2000).

*HCO<sub>3</sub><sup>-</sup> Effect.* All shoot growth parameters, water consumption, and total chlorophyll concentration, were decreased by the addition of  $\text{HCO}_3^-$  to the mixtures, demonstrating the detrimental effect of  $\text{HCO}_3^-$  (Fig. 6.8 to 6.12). Root mass increased in mixtures containing  $\text{HCO}_3^-$ , mainly in the  $\text{Na}^+$  pure blend (0:0:1)(Fig. 6.9).

The  $\text{K}^+$  pure blend, 0:1:0, containing no  $\text{HCO}_3^-$ , will be used as the reference point since it is very close to the level of  $\text{K}^+$  in Hoagland's nutrient solution and would be the mixture that is the closest to a control,

Compared to the  $\text{K}^+$  pure blend, the loss of shoot dry mass can be estimated as 19% due to the  $\text{Na}^+$  pure blend effect. The effect of the  $\text{Rb}^+$  pure blend was a 30% decrease in shoot mass. When  $\text{HCO}_3^-$  was added to the  $\text{Na}^+$  and  $\text{Rb}^+$  pure blends 0:0:1 and 1:0:0, respectively, the additional shoot mass loss was 15% and 18%, respectively. This is the  $\text{HCO}_3^-$  effect (Table 6.17).

*Separate Counter-Cation and HCO<sub>3</sub><sup>-</sup> Effect.* A criticism of above conclusions is that at both the  $\text{Rb}^+$  and  $\text{Na}^+$  pure blends leaf tissue  $\text{K}^+$  concentration was below the limit of 2.00%, indicating a possible hidden  $\text{K}^+$  deficiency (Fig. 6.14). This implies that  $\text{Rb}^+$  and  $\text{Na}^+$  toxicities were confounded with a possible  $\text{K}^+$  deficiency effect. For this reason, the  $\text{Na}^+$  and  $\text{Rb}^+$  toxicities are labeled as  $\text{Na}^+$  toxicity/ $\text{K}^+$  deficiency (Fig.

6.15) and  $\text{Rb}^+$  toxicity/ $\text{K}^+$  deficiency (Fig. 6.16), respectively, in Table 6.17. Since  $\text{K}^+$  leaf tissue concentration was higher than 2.00% in mixtures containing  $1/6$  of  $\text{K}^+$ , it is possible to eliminate the  $\text{K}^+$  deficiency effect by basing the conclusions on mixtures that contained a proportion of  $\text{K}^+$  higher than  $1/6$ . The centroid point was selected for this purpose since the proportion of  $\text{K}^+$  was  $1/3$ . Thus, at the centroid point, the effects measured are only the  $\text{Rb}^+ + \text{Na}^+$ , and  $\text{HCO}_3^-$  toxicity effects (Fig. 6.17), which was a shoot dry mass decreased of 16% for the  $\text{Rb}^+ + \text{Na}^+$ , and an additional 22% decrease for  $\text{HCO}_3^-$  (Table 6.17).

In summary,  $\text{Na}^+$  toxicities decreased shoot dry mass between 16 to 19%, respectively, while the  $\text{HCO}_3^-$  caused an additional 15 to 22% decrease. This indicates almost equal toxicity of  $\text{Na}^+$  and  $\text{HCO}_3^-$  from  $\text{NaHCO}_3$ .

Table 6.17. Percentage decrease in shoot dry mass due to the effect of the counter-cations,  $\text{HCO}_3^-$ , and interactions. Experiment 6.3.

Effect	$\text{HCO}_3^-$ (mM)	Location in the response surface	Shoot mass decrease
$\text{Na}^+$ toxicity/ $\text{K}^+$ deficiency	0	$\text{Na}^+$ vertex	19%
$\text{Rb}^+$ toxicity/ $\text{K}^+$ deficiency	0	$\text{Rb}^+$ vertex	30%
$\text{Rb}^+ + \text{Na}^+$ toxicity	0	Centroid	16%
$\text{HCO}_3^-$	7.5	$\text{Na}^+$ vertex	15%
$\text{HCO}_3^-$	7.5	$\text{Rb}^+$ vertex	18%
$\text{HCO}_3^-$	7.5	Centroid	22%

### Conclusions

The models selected predicted the blend for maximum shoot growth to be in the region of  $\text{K}^+$ , 0:1:0 mixture, while the lowest mass was in the  $\text{Rb}^+$  pure blend, 1:0:0 mixture. This was for both 0 and 7.5 mM  $\text{HCO}_3^-$ . For this reason, with or without  $\text{HCO}_3^-$ , the highest growth occurred in mixtures containing the  $\text{K}^+$  pure blend, while the lowest growth was in mixtures with the  $\text{Rb}^+$  pure blend.

The separate  $\text{HCO}_3^-$  effect and counter-cation effect indicates that the counter-cations of  $\text{HCO}_3^-$  are responsible of half of the reduction in shoot dry mass, while  $\text{HCO}_3^-$  is responsible for the reminding half.

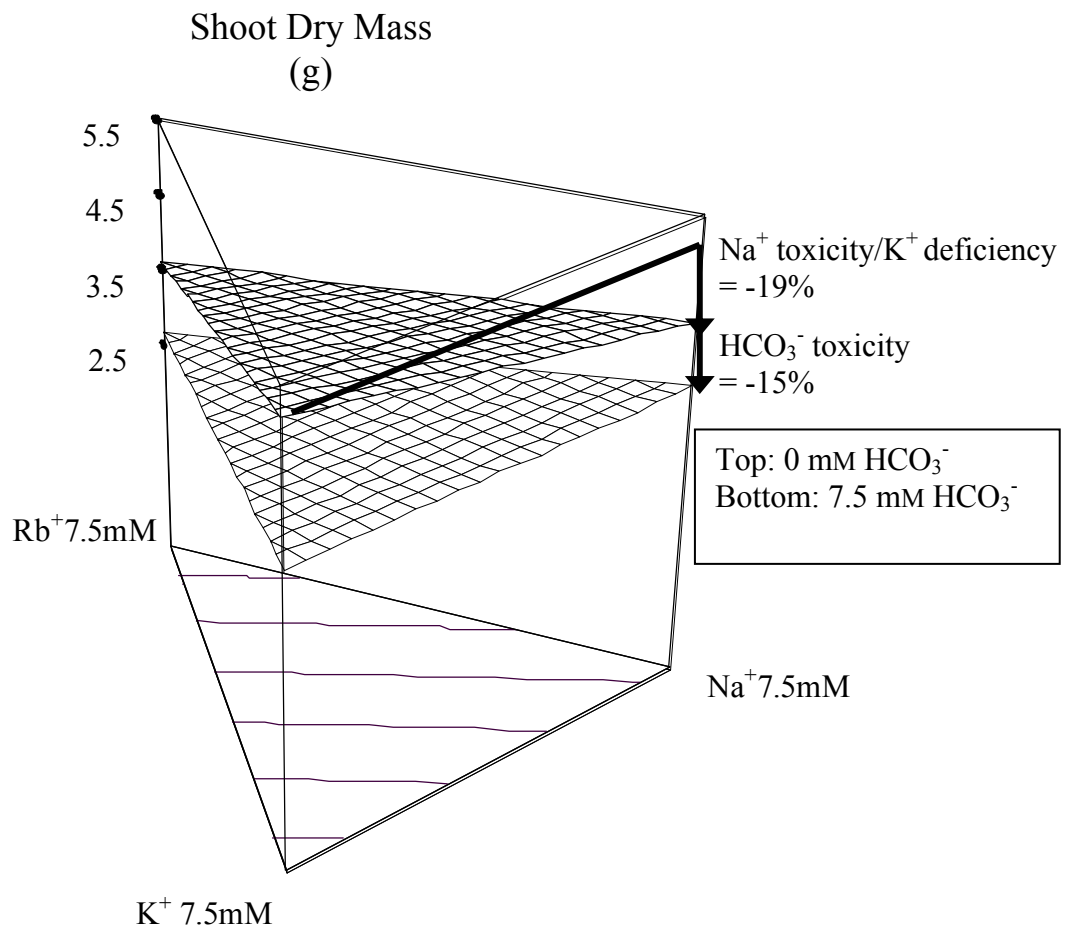

Fig. 6.15. Separation of the Na<sup>+</sup> toxicity/K<sup>+</sup> deficiency effect from the HCO<sub>3</sub><sup>-</sup> toxicity effect on shoot growth of bean, *Phaseolus vulgaris* L. 'Poncho', grown in hydroponics with 7.5 mM total concentration and two levels of HCO<sub>3</sub><sup>-</sup>, 0 mM (top response surface) and 7.5 mM (bottom response surface).

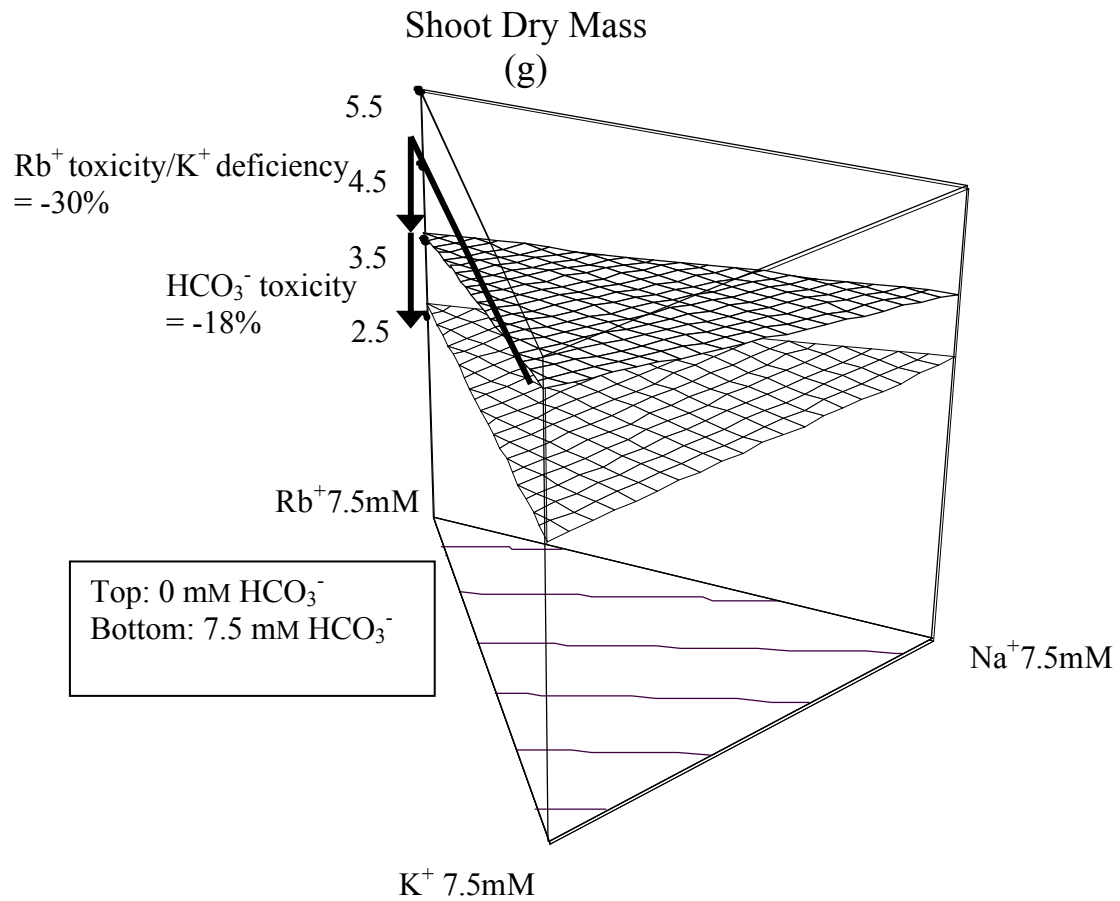

Fig. 6.16. Separation of the Rb<sup>+</sup> toxicity/K<sup>+</sup> deficiency effect from the HCO<sub>3</sub><sup>-</sup> toxicity effect on shoot growth of bean, *Phaseolus vulgaris* L. 'Poncho', grown in hydroponics with 7.5 mM total concentration and two levels of HCO<sub>3</sub><sup>-</sup>, 0 mM (top response surface) and 7.5 mM (bottom response surface).

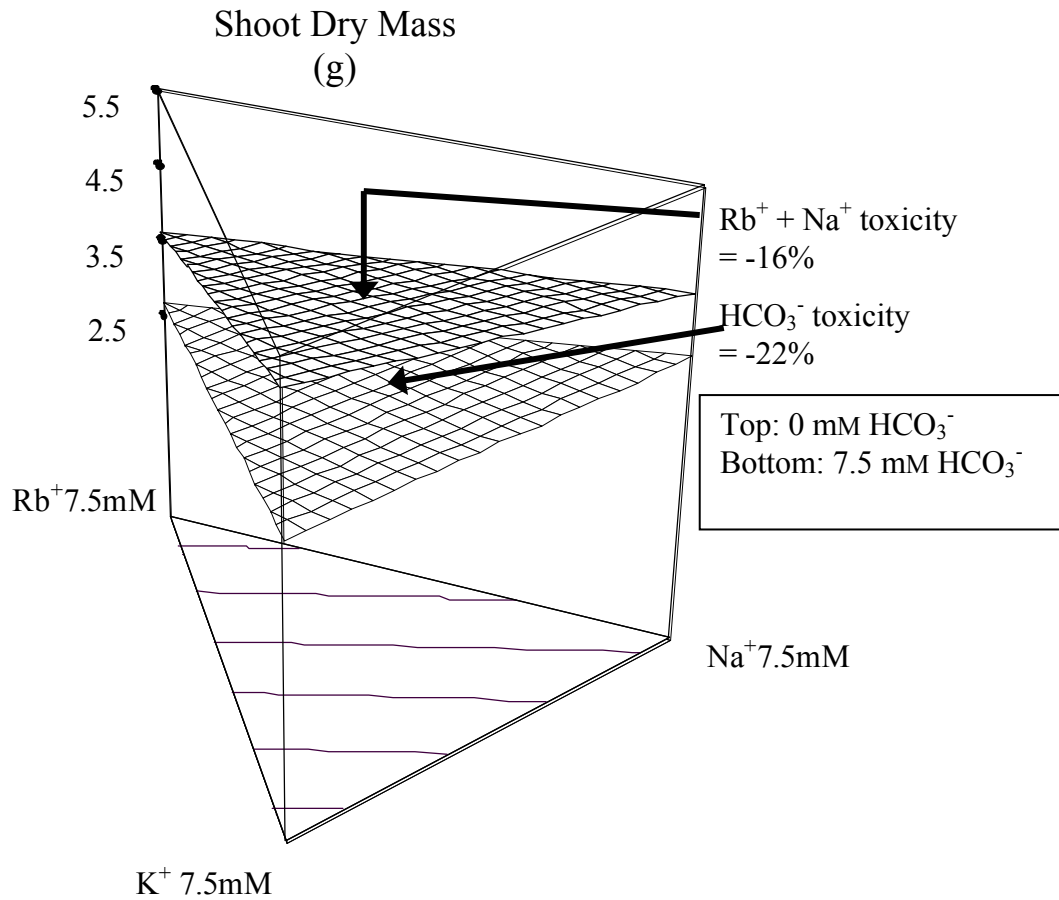

Fig. 6.17. Separation of the Rb<sup>+</sup> + Na<sup>+</sup> toxicity effect from the HCO<sub>3</sub><sup>-</sup> toxicity effect on shoot growth of bean, *Phaseolus vulgaris* L. 'Poncho', grown in hydroponics with 7.5 mM total concentration and two levels of HCO<sub>3</sub><sup>-</sup>, 0 mM (top response surface) and 7.5 mM (bottom response surface).

#### **Experiment 6.4. Effect of Mixtures of Rb<sup>+</sup>, K<sup>+</sup>, and Na<sup>+</sup> on the Response of Bean Plants to HCO<sub>3</sub><sup>-</sup>**

*Shoot and root mass*

0 mM HCO<sub>3</sub><sup>-</sup>

*Models.* The Rb<sup>+</sup>:K<sup>+</sup>:Na<sup>+</sup> treatments significantly affected ( $P \leq 0.05$ ) shoot and root mass according to ANOVA (Table 6.18). The response to the Rb<sup>+</sup>:K<sup>+</sup>:Na<sup>+</sup> mixtures fit a quadratic model (Table 6.19). The plant response is demonstrated in the response surface plots in Figs. 6.18 and 6.19.

*Pure Blends (Vertices).* Shoot and root mass were higher in the K<sup>+</sup> pure blend compared to the Na<sup>+</sup> and Rb<sup>+</sup> pure blends (Table 6.19). According to the estimated coefficients, and taking the K<sup>+</sup> pure blend, 0:1:0 mixture, as the reference mixture, the Na<sup>+</sup> pure blend caused a 38% and 21% decrease in the shoot and root dry mass, respectively. In the Rb<sup>+</sup> pure blend, shoot and root dry mass were decreased by 61% and 66%, respectively. Thus, the toxicity of the counter-cations was ranked Rb<sup>+</sup>>Na<sup>+</sup>>K<sup>+</sup>. The non overlapping 95% confidence intervals for the estimated shoot dry mass validate these conclusions (Table 6.20)

*Binary Blends (50%:50% Blends).* The Rb<sup>+</sup>:K<sup>+</sup> and Rb<sup>+</sup>:Na<sup>+</sup> binary blends, 1/2:1/2:0 and 1/2:0:1/2, respectively, induced an antagonistic effect on shoot mass. This was indicated by the negative coefficients,  $\beta_4$  and  $\beta_5$ , respectively, (Table 6.19), and the sunken response surface of the binary blends in Fig. 6.18. The K<sup>+</sup>:Na<sup>+</sup> binary blend induced a synergistic response, as indicated by the positive coefficient,  $\beta_6$ , and the raised response surface in Fig. 6.18. Root mass showed similar tendencies (Table 6.19)(Fig. 6.19).

*Coordinates (0% to 100% Blends).* The Rb<sup>+</sup> coordinate (Fig. 6.18) showed that increasing proportions of Rb<sup>+</sup> was associated to severe decrease in shoot and root mass (Fig. 6.18 and 6.19). The K<sup>+</sup> and Na<sup>+</sup> coordinate suggests that shoots and roots exhibited



Table 6.18. Effect of mixtures of varying proportions of Rb<sup>+</sup>, K<sup>+</sup>, and Na<sup>+</sup> counter-cations of HCO<sub>3</sub><sup>-</sup> on shoot, root, and leaf growth parameters of bean, *Phaseolus vulgaris* L. 'Poncho', plants grown in hydroponics with a 7.5 mM total concentration and two levels of HCO<sub>3</sub><sup>-</sup>. Experiment 6.4.

Mixture Rb <sup>+</sup> :K <sup>+</sup> :Na <sup>+</sup>	Shoot Dry Mass <sup>z</sup> (g)		Shoot Fresh Mass (g)		Root Dry Mass (g)		Root Fresh Mass (g)		Leaf Dry Mass (g)		Leaf Fresh Mass (g)	
	HCO <sub>3</sub> <sup>-</sup> (mM)											
	0	7.5	0	7.5	0	7.5	0	7.5	0	7.5	0	7.5
Pure blends												
1:0:0	5.4e	5.2e	40.8e	37.7f	0.9e	1.2f	11.7e	10.3e	3.2e	3.2e	26.9e	27.1d
0:1:0	14.9bc	14.6a	111.1bc	111.2a	2.5bc	4.1a	53.0ab	79.4a	8.2bc	8.3a	69.0bc	68.9a
0:0:1	10.6d	12.7ab	78.9d	93.7a-c	2.0cd	3.6a-c	38.1bc	59.5ab	6.2cd	7.2ab	50.9c-e	60.1ab
Binary blends												
<sup>1</sup> / <sub>2</sub> : <sup>1</sup> / <sub>2</sub> :0	8.5de	9.1b-e	70.9de	71.9c-f	1.7cd	2.1def	29.2c-e	27.8c-e	4.8de	5.1b-e	46.9de	44.5b-d
<sup>1</sup> / <sub>2</sub> :0: <sup>1</sup> / <sub>2</sub>	8.3de	6.3e	61.0de	45.3ef	1.3de	1.2f	15.5de	11.2de	4.8de	3.9de	41.7de	32.5cd
0: <sup>1</sup> / <sub>2</sub> : <sup>1</sup> / <sub>2</sub>	19.8a	12.7ab	144.8a	95.0ab	3.3a	3.9ab	67.7a	74.8a	11.1a	7.2ab	91.0a	59.8ab
Centroid												
<sup>1</sup> / <sub>3</sub> : <sup>1</sup> / <sub>3</sub> : <sup>1</sup> / <sub>3</sub>	11.6cd	8.2cde	88.4b-d	63.8c-f	2.0cd	2.1d-f	32.9b-d	26.9c-e	6.3cd	4.6c-e	56.2b-d	42.6b-d
Tertiary blends												
<sup>2</sup> / <sub>3</sub> : <sup>1</sup> / <sub>6</sub> : <sup>1</sup> / <sub>6</sub>	8.2de	6.6de	63.4de	48.8d-f	1.4de	1.7d-f	19.8c-e	18.0de	4.7de	3.7de	42.6de	32.3cd
<sup>1</sup> / <sub>6</sub> : <sup>2</sup> / <sub>3</sub> : <sup>1</sup> / <sub>6</sub>	16.4ab	10.8a-c	120.9ab	79.5a-c	2.8ab	2.8b-d	52.8ab	41.8bc	9.3ab	6.1a-c	78.8ab	51.8ab
<sup>1</sup> / <sub>6</sub> : <sup>1</sup> / <sub>6</sub> : <sup>2</sup> / <sub>3</sub>	11.2cd	11.0a-c	83.2cd	79.4b-d	2.4bc	2.7c-e	44.1bc	37.0cd	6.6cd	6.2a-d	54.3cd	51.1a-d
Significance <sup>y</sup>	***	***	***	***	***	***	***	***	***	***	***	***
R <sup>2</sup>	0.83	0.74	0.83	0.77	0.81	0.83	0.79	0.86	0.84	0.70	0.80	0.69
CV%	19.30	21.14	18.11	19.59	19.05	20.66	28.91	28.64	17.98	21.28	18.86	21.16

<sup>z</sup>Means within columns with same letter indicate non significant difference according to LSD multiple comparison test at  $P \leq 0.05$

<sup>y</sup>Significance according to ANOVA, NS, \*, \*\*, \*\*\* non significant, significant at  $P \leq 0.05$ ,  $P \leq 0.01$  and  $P \leq 0.001$ , respectively  
R<sup>2</sup>= Coefficient of determination      CV= Coefficient of variation

Table 6.19. Models<sup>z</sup> for the shoot, root, and leaf growth parameters of bean, *Phaseolus vulgaris* L. ‘Poncho’, plants in response to Rb<sup>+</sup>:K<sup>+</sup>:Na<sup>+</sup> mixtures with a 7.5 mM total concentration combined with two concentrations of HCO<sub>3</sub><sup>-</sup>. Experiment 6.4.

Coefficient <sup>y</sup>	Shoot Dry Mass (g)		Shoot Fresh Mass (g)		Root Dry Mass (g)		Root Fresh Mass (g)		Leaf Dry Mass (g)		Leaf Fresh Mass (g)	
	HCO <sub>3</sub> <sup>-</sup> (mM)											
	0	7.5	0	7.5	0	7.5	0	7.5	0	7.5	0	7.5
β <sub>1</sub>	+5.51	+5.28	+41.60	+38.42	+0.91	+1.31	+12.09	+13.44	+3.24	+3.23	+27.62	+27.17
β <sub>2</sub>	+17.81	+14.41	+129.28	+109.14	+2.70	+3.94	+60.12	+77.04	+9.61	+8.18	+81.12	+68.00
β <sub>3</sub>	+11.02	+13.00	+83.31	+95.27	+2.13	+3.63	+40.67	+59.24	+6.48	+7.35	+54.64	+60.88
β <sub>4</sub>	-7.55	-4.10	-25.86	-17.57	+0.16	-2.00	-24.74	-79.52	-3.87	-3.33	-7.76	-16.49
β <sub>5</sub>	-1.07	-10.86	-14.67	-83.14	-1.21	-4.88	-45.18	+103.74	-1.27	-5.78	-6.79	-44.26
β <sub>6</sub>	+13.53	-4.56	+96.42	-35.32	+3.27	+0.11	+66.99	+3.43	+9.20	-2.87	-64.92	-19.79
β <sub>7</sub>	-	-	-	-	-	-	-	-	-	-	-	-
Model	Quadratic		Quadratic		Quadratic		Quadratic		Quadratic		Quadratic	
Lack of fit <sup>x</sup>	P=0.625		P=0.677		P=0.496		P=0.262		P=0.607		P=0.774	
Adeq. Prec.	18.02		19.03		17.29		16.38		17.38		16.69	
R <sup>2</sup>	0.81		0.83		0.82		0.82		0.79		0.78	
CV%	17.79		16.54		20.43		29.36		18.38		17.88	

<sup>z</sup>To estimate any parameter, multiply the coefficients indicated in the table by the proportion of the corresponding counter-ion in the mixture of interest

<sup>y</sup>β<sub>1</sub>: Rb<sup>+</sup>, β<sub>2</sub>: K<sup>+</sup>, β<sub>3</sub>: Na<sup>+</sup>, β<sub>4</sub>: Rb<sup>+</sup>\*K<sup>+</sup>, β<sub>5</sub>: Rb<sup>+</sup>\*Na<sup>+</sup>, β<sub>6</sub>: K<sup>+</sup>\*Na<sup>+</sup>, β<sub>7</sub>: Rb<sup>+</sup>\*K<sup>+</sup>\*Na<sup>+</sup>

<sup>x</sup>Lack of fit according to ANOVA

Adeq. Prec.=Adequate precision

R<sup>2</sup>= Coefficient of determination

CV= Coefficient of variation

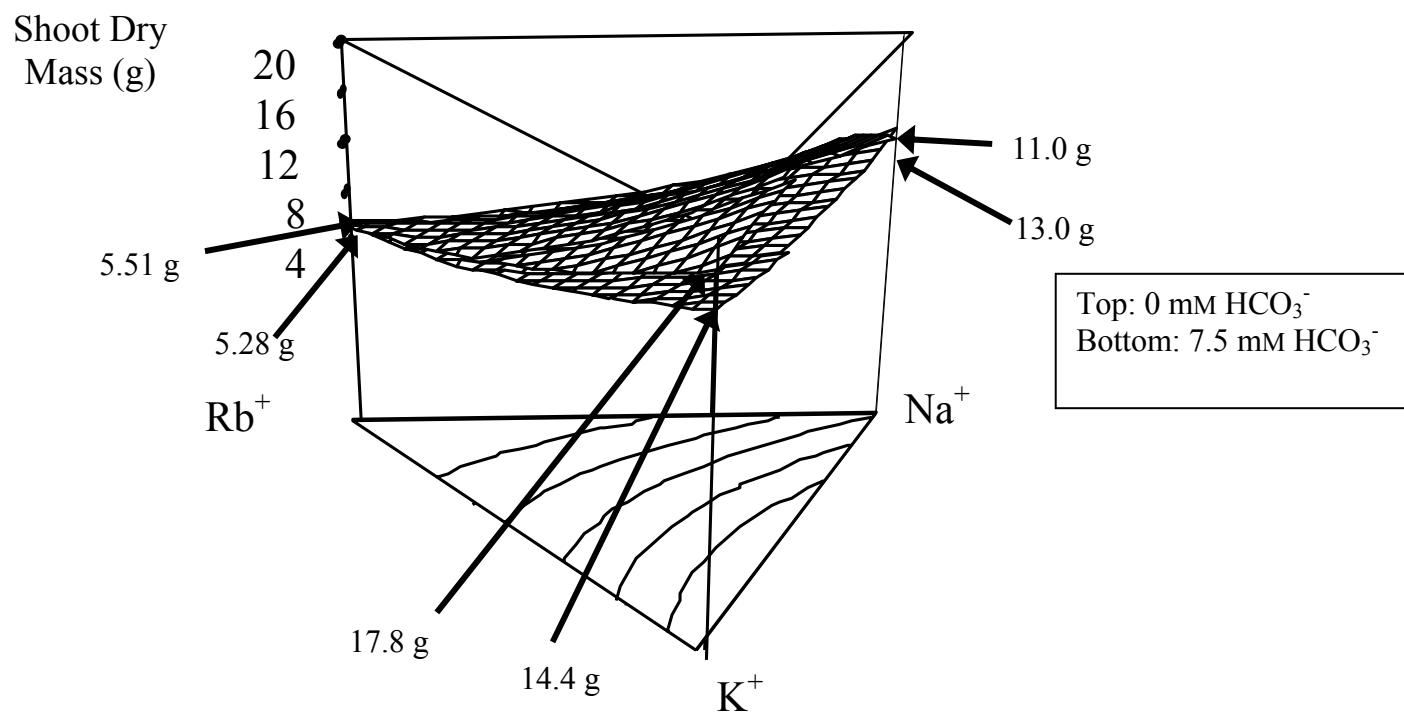

Fig. 6.18. Effect of mixtures of varying proportions of Rb<sup>+</sup>, K<sup>+</sup>, and Na<sup>+</sup> as counter-cations of HCO<sub>3</sub><sup>-</sup> on shoot dry mass of bean, *Phaseolus vulgaris* L. 'Poncho', grown in hydroponics with 7.5 mM total concentration and two levels of HCO<sub>3</sub><sup>-</sup>.

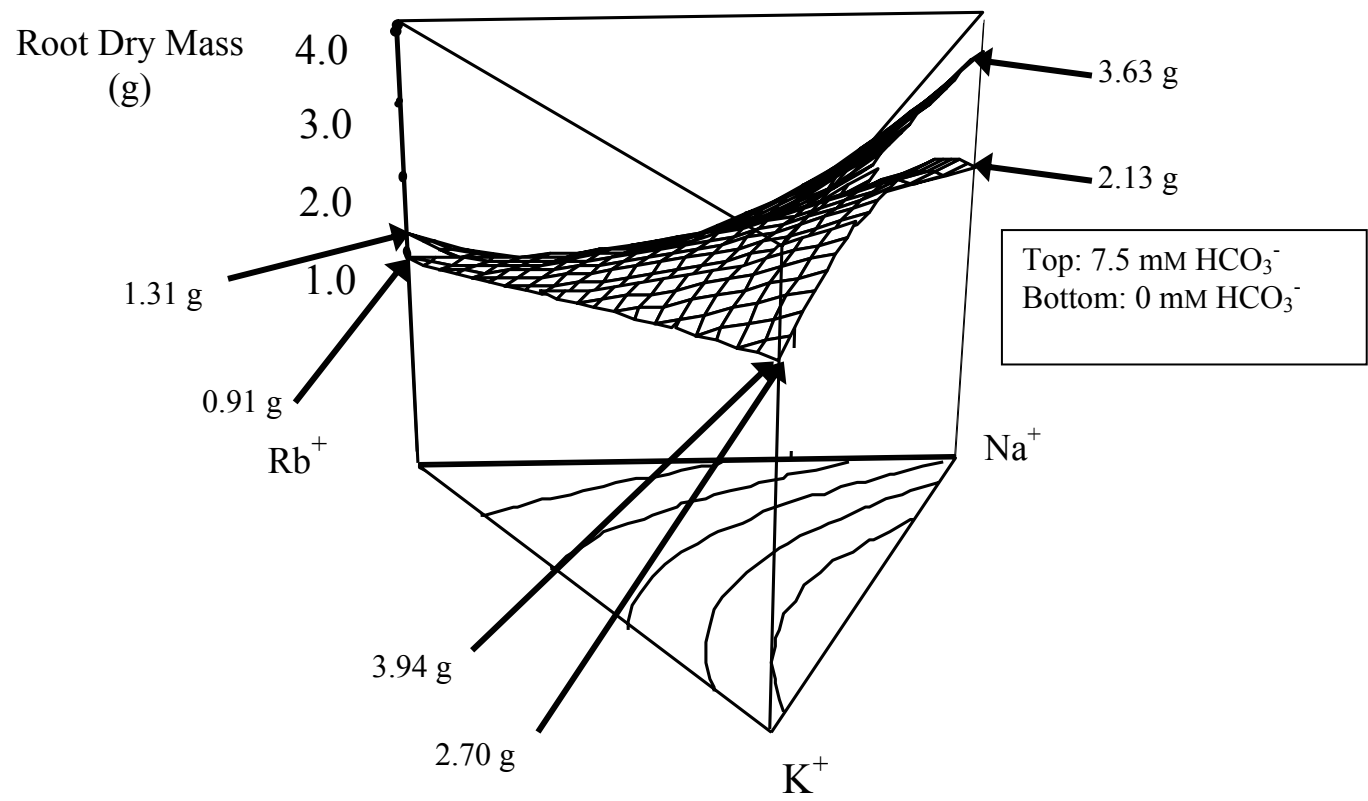

Fig. 6.19. Effect of mixtures of varying proportions of Rb<sup>+</sup>, K<sup>+</sup>, and Na<sup>+</sup> as counter-cations of HCO<sub>3</sub><sup>-</sup> on root dry mass of bean, *Phaseolus vulgaris* L. 'Poncho', grown in hydroponics with 7.5 mM total concentration and two levels of HCO<sub>3</sub><sup>-</sup>.

Table 6.20. Predicted response and 95% confidence interval for growth parameters evaluated of bean, *Phaseolus vulgaris* L. 'Poncho', plants grown in mixtures of varying proportions of Rb<sup>+</sup>, K<sup>+</sup>, and Na<sup>+</sup> counter-cations of HCO<sub>3</sub><sup>-</sup> with 7.5 mM total concentration and two concentrations of HCO<sub>3</sub><sup>-</sup>. Experiment 6.4.

Mixtures Rb <sup>+</sup> :K <sup>+</sup> :Na <sup>+</sup>	Shoot Dry Mass (g)		Root Dry Mass (g)			Leaf Area (cm <sup>2</sup> )			Solution pH			Total Chlorophyll (µg·cm <sup>-2</sup> )			
	CI <sub>L</sub> <sup>z</sup>	CI <sub>H</sub> <sup>y</sup>	CI <sub>L</sub>	CI <sub>H</sub>	CI <sub>L</sub>	CI <sub>H</sub>	CI <sub>L</sub>	CI <sub>H</sub>	CI <sub>L</sub>	CI <sub>H</sub>	CI <sub>L</sub>	CI <sub>H</sub>	CI <sub>L</sub>	CI <sub>H</sub>	
Rb <sup>+</sup> -K <sup>+</sup> -Na <sup>+</sup>	0 mM HCO <sub>3</sub> <sup>-</sup>														
1 0 0	3.74	5.51	7.28	0.47	0.91	1.36	663	1063	1462	5.01	5.46	5.90	3.27	4.24	5.21
0 1 0	15.79	17.81	19.82	2.20	2.70	3.21	3543	3999	4454	6.56	7.07	7.59	7.40	8.50	9.61
0 0 1	8.99	11.02	13.05	1.62	2.13	2.64	2779	2320	3238	6.33	6.85	7.36	7.09	8.21	9.32
	7.5 mM HCO <sub>3</sub> <sup>-</sup>														
1 0 0	3.76	5.28	6.86	0.91	1.31	1.71	669	1026	1383	7.92	8.32	8.72	3.36	4.32	5.10
0 1 0	12.65	14.41	16.17	3.50	3.94	4.39	2875	3273	3671	7.84	8.29	8.74	6.05	7.02	7.99
0 0 1	11.40	12.99	14.58	3.23	3.63	4.03	2629	2987	3346	7.83	8.24	8.64	5.89	6.77	7.64

<sup>z</sup>CI<sub>L</sub>=low confidence interval

<sup>y</sup>CI<sub>H</sub>=high confidence interval

a higher mass at intermediate proportions of these counter-cations, but higher proportions were slightly detrimental.

*Optimization.* The highest shoot and root mass observed in the response surface was in the region of  $K^+$  and  $Na^+$  (Fig. 6.18 and 6.19). The model predicted that the best  $Rb^+ : K^+ : Na^+$  mixture was the 0:0.59:0.41 blend, with a shoot mass yield of 20.0 g. The lowest yield was predicted at the 1:0:0 mixture, 5.54 g. Maximum root dry mass was predicted for the 0:0.56:0.44 mixture and minimum mass at the 1:0:0 mixture.

7.5 mM  $HCO_3^-$

*Models.* Similar to the 0 mM  $HCO_3^-$ , the  $Rb^+ : K^+ : Na^+$  treatments affected significantly shoot and root mass according to ANOVA (Table 6.18) and the response to the  $Rb^+ : K^+ : Na^+$  mixtures fit a quadratic model (Table 6.19).

*Pure Blends (Vertices).* Shoot and root mass were higher in the  $K^+$  pure blend compared to the  $Na^+$  and  $Rb^+$  pure blends (Table 6.19). According to the estimated coefficients, and taking the  $K^+$  pure blend as the reference mixture, the  $Na^+$  blend caused a 10% and 8% decrease in the shoot and root dry mass, respectively. Shoot and root dry mass were decreased by 63% and 67%, respectively, in the  $Rb^+$  pure blend. Thus, the toxicity of the counter-cations was ranked  $Rb^+ > Na^+ \approx K^+$ . These effects are visualized in the response surface graphs in Fig. 6.18 and 6.19.

*Binary Blends (50%:50% Blends).* All the binary blends induced an antagonistic effect on shoot and root mass, as indicated by the negative coefficients  $\beta_4$ ,  $\beta_5$ , and  $\beta_6$  (Table 6.19), and the sunken response surface of the binary blends in Fig. 6.18 and 6.19.

*Coordinates (0% to 100% Blends).* Shoot and root mass were increased by increasing proportions of  $K^+$  and  $Na^+$  (Fig. 6.18 and 6.19), as indicated by the slope of the coordinates. The  $Rb^+$  coordinate showed that increasing proportion was associated to a severe decrease in shoot (Fig. 6.18) and root mass (Fig. 6.19).

*Optimization.* The optimum shoot and root mass was predicted by the models to be in the 0:1:0  $Rb^+ : K^+ : Na^+$  mixture, 14.4 and 3.94 g, respectively. The lowest shoot and root yield was predicted at the 0.85:0:0.15 and 0.74:0:0.26 mixtures, respectively.

*General Effect of  $\text{HCO}_3^-$ .* Bicarbonate induced a slight decrease in shoot mass (Table 6.19)(Fig. 6.18) at the  $\text{K}^+$  and  $\text{Rb}^+$  vertices, but induced an increase in root mass (Table 6.19)(Fig. 6.19). Shoot mass decreased by 19% in the  $\text{K}^+$  pure blend, while in the  $\text{Rb}^+$  blend the decrease was 4%. Shoot mass increased 18% by effect of  $\text{HCO}_3^-$  in the  $\text{Na}^+$  pure blend (Table 6.19). This was corroborated by the small coefficients in the final models (Table 6.21).

According to the coefficients estimated (Table 6.19), root dry mass increased in plants treated with  $\text{HCO}_3^-$  by 44%, 46%, and 70% when the pure blends were  $\text{Rb}^+$ ,  $\text{K}^+$ , and  $\text{Na}^+$ , respectively.

#### *Leaf growth*

The  $\text{Rb}^+:\text{K}^+:\text{Na}^+$  treatments affected significantly ( $P \leq 0.05$ ) leaf growth parameters (Tables 6.18 and 6.22) at both levels of  $\text{HCO}_3^-$ , according to ANOVA.

The models are shown in Tables 6.19 and 6.23. Figures 6.20 and 6.21 show the response surface for leaf area and leaf dry mass. The best model for leaf area and leaf dry and fresh mass was very similar to the shoot mass model, as well as the effect of vertices and coordinates, and the optimum mixture. A linear model best fit the response of leaf number (Table 6.23). In general, the addition of 7.5 mM  $\text{HCO}_3^-$  induced a decrease in the number of leaves regardless of the counter-cation, but this decrease was greatest with the  $\text{K}^+$  and  $\text{Rb}^+$  pure blends (Table 6.23).

#### *Shoot:root ratio*

The  $\text{Rb}^+:\text{K}^+:\text{Na}^+$  treatments affected significantly ( $P \leq 0.05$ ) the shoot:root ratio at 0 and 7.5 mM  $\text{HCO}_3^-$ , according to ANOVA (Table 6.22). A special cubic model best fit the shoot:root ratio response to  $\text{Rb}^+:\text{K}^+:\text{Na}^+$  mixtures (Table 6.23).

In general,  $\text{HCO}_3^-$  decreased the shoot:root ratio (Table 6.23). The detrimental effect of  $\text{HCO}_3^-$  was greatest in the  $\text{K}^+$  and  $\text{Na}^+$  pure blends, as indicated by the estimated coefficients,  $\beta_1$  and  $\beta_2$ , respectively (Table 6.23). This was corroborated by the negative coefficients of the interactions of each counter-cation with  $\text{HCO}_3^-$  in the final equation (Table 6.21).

Table 6.21. Final equations for the growth parameters of bean, *Phaseolus vulgaris* L. ‘Poncho’, plants in response to Rb<sup>+</sup>:K<sup>+</sup>:Na<sup>+</sup> mixtures with a 7.5 mM total concentration combined with two concentrations of HCO<sub>3</sub><sup>-</sup>. Experiment 6.4.

Parameter	Final equation <sup>z</sup>
Shoot Dry Mass (g)	5.39Rb + 16.11K + 12.00Na - 5.86Rb*K - 5.97Rb*Na + 4.54K*Na - 1.70K*HCO <sub>3</sub> <sup>-</sup> + 0.98Na*HCO <sub>3</sub> <sup>-</sup> + 1.73Rb*HCO <sub>3</sub> <sup>-</sup> - 4.89Rb*Na*HCO <sub>3</sub> <sup>-</sup> - 9.00 K*Na*HCO <sub>3</sub> <sup>-</sup>
Shoot Fresh Mass (g)	40.0Rb + 119.5K + 88.3Na - 21.7Rb*K - 48.9Rb*Na + 30.6K*Na - 10.3K*HCO <sub>3</sub> <sup>-</sup> + 6.0Na*HCO <sub>3</sub> <sup>-</sup> + 4.1Rb*HCO <sub>3</sub> <sup>-</sup> - 32.2Rb*Na*HCO <sub>3</sub> <sup>-</sup> - 65.9K*Na*HCO <sub>3</sub> <sup>-</sup>
Root Dry Mass (g)	1.11Rb + 3.32K + 2.88Na - 0.92Rb*K - 3.05Rb*Na + 1.69K*Na + 0.62K*HCO <sub>3</sub> <sup>-</sup> + 0.75Na*HCO <sub>3</sub> <sup>-</sup> - 1.08Rb*HCO <sub>3</sub> <sup>-</sup> - 1.84Rb*Na*HCO <sub>3</sub> <sup>-</sup> - 1.58K*Na*HCO <sub>3</sub> <sup>-</sup>
Root Fresh Mass (g)	12.77Rb + 60.12K + 49.95Na - 52.13Rb*Na - 74.46Rb*Na + 0.67Rb*HCO <sub>3</sub> <sup>-</sup> + 35.21K*HCO <sub>3</sub> <sup>-</sup> + 8.46K*HCO <sub>3</sub> <sup>-</sup> + 9.28Na*HCO <sub>3</sub> <sup>-</sup> - 27.28Rb*Na*HCO <sub>3</sub> <sup>-</sup> - 29.28Rb*Na*HCO <sub>3</sub> <sup>-</sup> - 31.78K*NaHCO <sub>3</sub> <sup>-</sup>
Leaf Dry Mass (g)	2.51Rb + 8.86K + 6.93Na - 0.13Rb*HCO <sub>3</sub> <sup>-</sup> - 1.26K*HCO <sub>3</sub> <sup>-</sup> - 0.35Na*HCO <sub>3</sub> <sup>-</sup>
Leaf Fresh Mass (g)	27.4Rb + 74.6K + 57.7Na - 12.1Rb*K - 25.5Rb*Na + 22.6K*Na - 6.6K*HCO <sub>3</sub> <sup>-</sup> + 3.0Na*HCO <sub>3</sub> <sup>-</sup> - 4.4Rb*HCO <sub>3</sub> <sup>-</sup> - 18.7Rb*Na*HCO <sub>3</sub> <sup>-</sup> - 42.4K*Na*HCO <sub>3</sub> <sup>-</sup>
Leaf Area (cm <sup>2</sup> )	1044Rb + 3636K + 2883Na - 645Rb*K - 1469Rb*Na + 1364K*Na - 363K*HCO <sub>3</sub> <sup>-</sup> + 104Na*HCO <sub>3</sub> <sup>-</sup> - 704Rb*HCO <sub>3</sub> <sup>-</sup> - 1230Rb*Na*HCO <sub>3</sub> <sup>-</sup> - 2331K*Na*HCO <sub>3</sub> <sup>-</sup>
Leaf number	17.96Rb + 39.07K + 28.28Na - 2.27Rb*HCO <sub>3</sub> <sup>-</sup> - 5.14K*HCO <sub>3</sub> <sup>-</sup> - 1.79Na*HCO <sub>3</sub> <sup>-</sup>
Shoot:Root Ratio (g·g <sup>-1</sup> )	4.77Rb + 5.12K + 4.41Na - 0.38Rb*K + 5.87Rb*Na - 0.07Rb*HCO <sub>3</sub> <sup>-</sup> - 0.35K*Na - 1.38K*HCO <sub>3</sub> <sup>-</sup> - 0.80Na*HCO <sub>3</sub> <sup>-</sup> - 17.39Rb*K*Na - 0.95Rb*K*HCO <sub>3</sub> <sup>-</sup> + 0.24Rb*Na*HCO <sub>3</sub> <sup>-</sup> + 0.52K*Na*HCO <sub>3</sub> <sup>-</sup> - 15.56Rb*K*Na*HCO <sub>3</sub> <sup>-</sup>
Solution pH	6.89Rb + 7.68K + 7.54Na + 0.94Rb*K - 2.08Rb*Na + 0.52K*Na + 0.61K*HCO <sub>3</sub> <sup>-</sup> + 0.69Na*HCO <sub>3</sub> <sup>-</sup> - 1.04Rb*HCO <sub>3</sub> <sup>-</sup> + 1.71Rb*Na*HCO <sub>3</sub> <sup>-</sup> - 0.21K*Na*HCO <sub>3</sub> <sup>-</sup>
Total Chlorophyll (µg·cm <sup>-2</sup> )	4.28Rb + 7.76K + 7.49Na - 2.99Rb*K - 5.20Rb*Na - 0.82K*Na - 0.74K*HCO <sub>3</sub> <sup>-</sup> - 0.72Na*HCO <sub>3</sub> <sup>-</sup> + 0.04Rb*HCO <sub>3</sub> <sup>-</sup> + 1.26Rb*Na*HCO <sub>3</sub> <sup>-</sup> + 0.64K*Na*HCO <sub>3</sub> <sup>-</sup>

<sup>z</sup>To estimate the response, the counter-ions must be expressed in terms of their proportion in the mixture of interest and HCO<sub>3</sub><sup>-</sup> takes a -1 or +1 value at a concentration of 0 and 7.5 mM, respectively



Table 6.22. Effect of mixtures of varying proportions of Rb<sup>+</sup>, K<sup>+</sup>, and Na<sup>+</sup> counter-cations of HCO<sub>3</sub><sup>-</sup> on leaf area, leaf number, shoot:root ratio, solution pH, and total chlorophyll concentration of bean, *Phaseolus vulgaris* L. ‘Poncho’, plants grown in hydroponics with a 7.5 mM total concentration and two levels of HCO<sub>3</sub><sup>-</sup>. Experiment 6.4.

Mixture Rb <sup>+</sup> :K <sup>+</sup> :Na <sup>+</sup>	Leaf Area (cm <sup>2</sup> )		Leaf Number		Shoot:Root Ratio (g·g <sup>-1</sup> )		Solution pH		Total Chlorophyll (µg·cm <sup>-2</sup> )	
	HCO <sub>3</sub> <sup>-</sup> (mM)									
	0	7.5	0	7.5	0	7.5	0	7.5	0	7.5
Pure blends										
1:0:0	1060f	1017e	20.0c	18.0b	4.72de	4.71b	5.50c	8.41	4.32a	4.88bc
0:1:0	3538bc	3361a	39.6ab	40.5a	6.44ab	3.61d	7.01ab	8.23	8.39a	6.97a
0:0:1	2658cde	2950ab	27.3bc	29.2ab	5.28cde	3.68cd	6.80ab	8.28	8.10ab	6.82a
Binary blends										
<sup>1</sup> / <sub>2</sub> : <sup>1</sup> / <sub>2</sub> :0	2536cde	2176bc	21.7c	24.6b	5.06cde	4.55bc	6.35abc	8.34	5.15de	4.85bc
<sup>1</sup> / <sub>2</sub> :0: <sup>1</sup> / <sub>2</sub>	1925ef	1266de	30.0abc	19.0b	6.67a	6.08a	5.67c	8.23	3.87e	4.59bc
0: <sup>1</sup> / <sub>2</sub> : <sup>1</sup> / <sub>2</sub>	4783a	2901ab	46.4a	29.4ab	45.54bcde	3.70cd	7.20a	8.30	7.31abc	6.68a
Centroid										
<sup>1</sup> / <sub>3</sub> : <sup>1</sup> / <sub>3</sub> : <sup>1</sup> / <sub>3</sub>	3153bcd	2088bcd	30.8abc	20.6b	5.92abc	3.68cd	6.26bc	8.30	6.40cd	5.79ab
Tertiary blends										
<sup>2</sup> / <sub>3</sub> : <sup>1</sup> / <sub>6</sub> : <sup>1</sup> / <sub>6</sub>	2061def	1416cde	26.5bc	22.2b	5.78abcd	3.73cd	5.56c	8.14	4.67e	4.20c
<sup>1</sup> / <sub>6</sub> : <sup>2</sup> / <sub>3</sub> : <sup>1</sup> / <sub>6</sub>	4048ab	2396b	38.8ab	22.8b	6.40ab	3.87bcd	7.03ab	8.30	7.26abc	6.24a
<sup>1</sup> / <sub>6</sub> : <sup>1</sup> / <sub>6</sub> : <sup>2</sup> / <sub>3</sub>	2812cde	2432b	21.7bc	27.8b	4.59ede	4.11bcd	6.35abc	8.26	6.83bc	5.63ab
Significance <sup>y</sup>	***	***	**	***	**	***	**	NS	***	***
R <sup>2</sup>	0.83	0.81	0.53	0.69	0.53	0.64	0.56	0.38	0.73	0.58
CV%	19.23	18.65	27.80	25.98	13.39	15.27	9.88	1.20	17.12	16.54

<sup>z</sup>Means followed by the same letter indicates non significant difference according to the LSD multiple comparison test at  $P \leq 0.05$

<sup>y</sup>Significance according to ANOVA, NS, \*, \*\*, \*\*\* non significant, and significant at  $P \leq 0.05$ ,  $P \leq 0.01$ , and  $P \leq 0.001$ , respectively

R<sup>2</sup>= Coefficient of determination      CV= Coefficient of variation

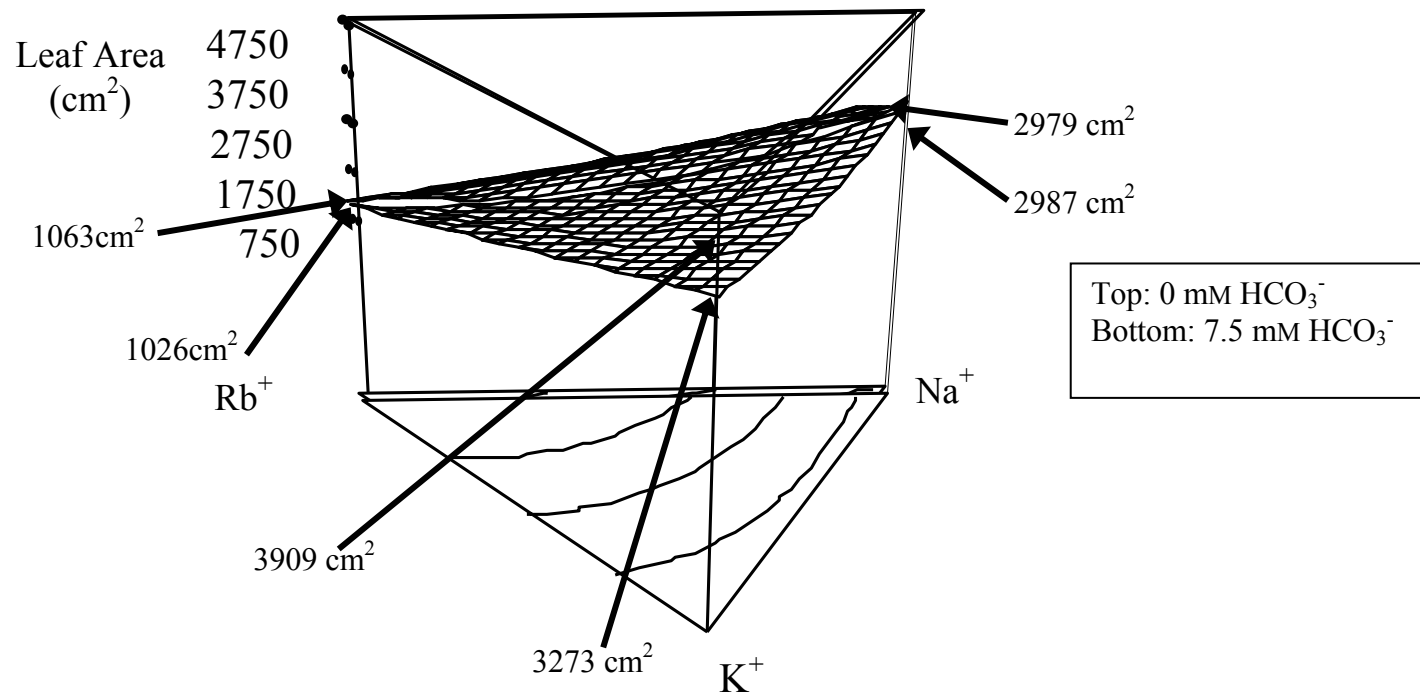

Fig. 6.20. Effect of mixtures of varying proportions of Rb<sup>+</sup>, K<sup>+</sup>, and Na<sup>+</sup> as counter-cations of HCO<sub>3</sub><sup>-</sup> on leaf area of bean, *Phaseolus vulgaris* L. 'Poncho', grown in hydroponics with 7.5 mM total concentration and two levels of HCO<sub>3</sub><sup>-</sup>.

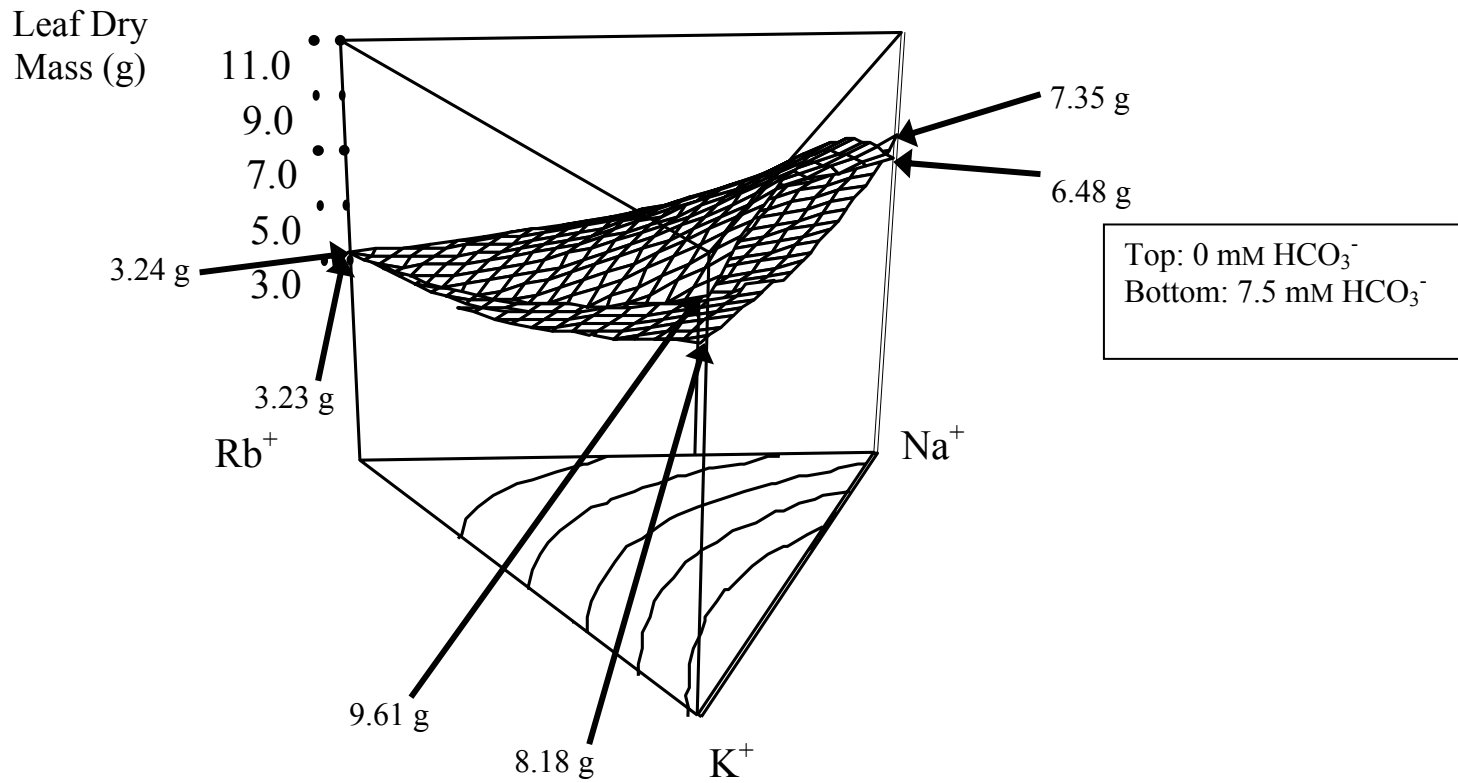

Fig. 6.21. Effect of mixtures of varying proportions of Rb<sup>+</sup>, K<sup>+</sup>, and Na<sup>+</sup> as counter-cations of HCO<sub>3</sub><sup>-</sup> on leaf dry mass of bean, *Phaseolus vulgaris* L. ‘Poncho’, grown in hydroponics with 7.5 mM total concentration and two levels of HCO<sub>3</sub><sup>-</sup>.

Table 6.23. Models<sup>z</sup> for leaf area, leaf number, shoot:root ratio, solution pH, and total chlorophyll concentration of bean, *Phaseolus vulgaris* L. ‘Poncho’, plants in response to Rb<sup>+</sup>:K<sup>+</sup>:Na<sup>+</sup> mixtures with a 7.5 mM total concentration combined with two concentrations of HCO<sub>3</sub><sup>-</sup>. Experiment 6.4.

Coefficient <sup>y</sup>	Leaf Area (cm <sup>-2</sup> )		Leaf Number		Shoot:Root Ratio (g·g <sup>-1</sup> )		Solution pH		Total Chlorophyll (µg·cm <sup>-2</sup> )	
	HCO <sub>3</sub> <sup>-</sup> (mM)									
	0	7.5	0	7.5	0	7.5	0	7.5	0	7.5
β <sub>1</sub>	+1062.7	+1026.1	+20.23	+15.69	+4.80	+4.66	+5.46	+8.32	+4.24	+4.32
β <sub>2</sub>	+3908.7	+3273.1	+44.20	+33.93	+6.50	+3.75	+7.07	+8.29	+8.50	+7.02
β <sub>3</sub>	+2979.2	+2987.0	+30.07	+26.49	+5.20	+3.61	+6.85	+8.24	+8.21	+6.77
β <sub>4</sub>	+1349.0	-58.4	-	-	-1.33	+0.56	+1.98	-0.10	-3.03	-2.95
β <sub>5</sub>	-238.4	-2698.8	-	-	+5.63	+6.11	-3.78	-0.37	-6.46	-3.94
β <sub>6</sub>	+3695.2	-967.7	-	-	-0.87	+0.17	+0.73	+0.30	-1.46	-0.18
β <sub>7</sub>	-	-	-	-	-1.83	-32.95	-	-	-	-
Model	Quadratic		Linear		Special cubic		Quadratic		Quadratic	
Lack of fit <sup>x</sup>	P=0.710		P=0.127		P=0.004		P=0.986		P=0.520	
Adeq. Prec.	20.96		14.37		9.56		17.79		11.17	
R <sup>2</sup>	0.85		0.44		0.66		0.86		0.65	
CV%	16.94		26.86		15.81		6.29		17.42	

<sup>z</sup>To estimate any parameter, multiply the coefficients indicated in the table by the proportion of the corresponding counter-ion in the mixture of interest

<sup>y</sup>β<sub>1</sub>: Rb<sup>+</sup>, β<sub>2</sub>: K<sup>+</sup>, β<sub>3</sub>: Na<sup>+</sup>, β<sub>4</sub>: Rb<sup>+</sup>\*K<sup>+</sup>, β<sub>5</sub>: Rb<sup>+</sup>\*Na<sup>+</sup>, β<sub>6</sub>: K<sup>+</sup>\* Na<sup>+</sup>, β<sub>7</sub>: Rb<sup>+</sup>\* K<sup>+</sup>:\*Na<sup>+</sup>

<sup>x</sup>Lack of fit according to ANOVA

Adeq. Prec.=Adequate precision

R<sup>2</sup>= Coefficient of determination

CV= Coefficient of variation

The coefficients for the pure blends indicated that the largest ratio was obtained with  $K^+$  ( $\beta_1$ ) and  $Na^+$  ( $\beta_2$ ) pure blends with no  $HCO_3^-$  added (Table 6.23), but in mixtures containing  $HCO_3^-$  the  $Rb^+$  ( $\beta_1$ ) pure blend induced the largest ratio (Table 6.23).

#### *Total chlorophyll*

The  $Rb^+:K^+:Na^+$  treatments affected significantly ( $P \leq 0.05$ ) total chlorophyll concentration at 0 and 7.5 mM  $HCO_3^-$ , according to ANOVA (Table 6.22). A quadratic model best fit the total chlorophyll response to the  $Rb^+:K^+:Na^+$  mixtures (Table 6.23).

In general,  $HCO_3^-$  induced a slight decrease in chlorophyll concentration, as demonstrated by the different elevation of the response surfaces in Fig. 6.22. The final equation supported this fact since the coefficients for the interaction of each counter-cation and  $HCO_3^-$  were negative (Table 6.21).

The greatest decrease in chlorophyll concentration due to the addition of 7.5 mM  $HCO_3^-$  was in the  $K^+$  and  $Na^+$  pure blends (Table 6.23)(Fig. 6.22). The intervals for  $K^+$  and  $Na^+$  did not overlap at both concentrations of  $HCO_3^-$ , indicating that both counter-cations affected total chlorophyll similarly (Table 6.20). Rubidium pure blends resulted with the lowest chlorophyll concentration of all mixtures; chlorophyll concentration was not further decreased by the addition of  $HCO_3^-$  (Fig. 6.22).

The coordinates showed that chlorophyll concentration increased as the proportion of  $K^+$  and  $Na^+$  approached to 0:1:0 or 0:0:1, respectively, regardless of the concentration of  $HCO_3^-$  (Fig 6.15). As the proportion of  $Rb^+$  augmented in the mixture, the concentration of the chlorophyll decreased (Fig. 6.22).

#### *Solution final pH*

The  $Rb^+:K^+:Na^+$  treatments significantly affected ( $P \leq 0.05$ ) solution final pH (Table 6.21) at 0 mM  $HCO_3^-$ , according to ANOVA. When 7.5 mM  $HCO_3^-$  was added to the treatments, there was not a significant effect by the  $Rb^+:K^+:Na^+$  treatments (Table 6.22). The response of solution pH to the  $Rb^+:K^+:Na^+$  mixtures best fit a quadratic model (Table 6.22).

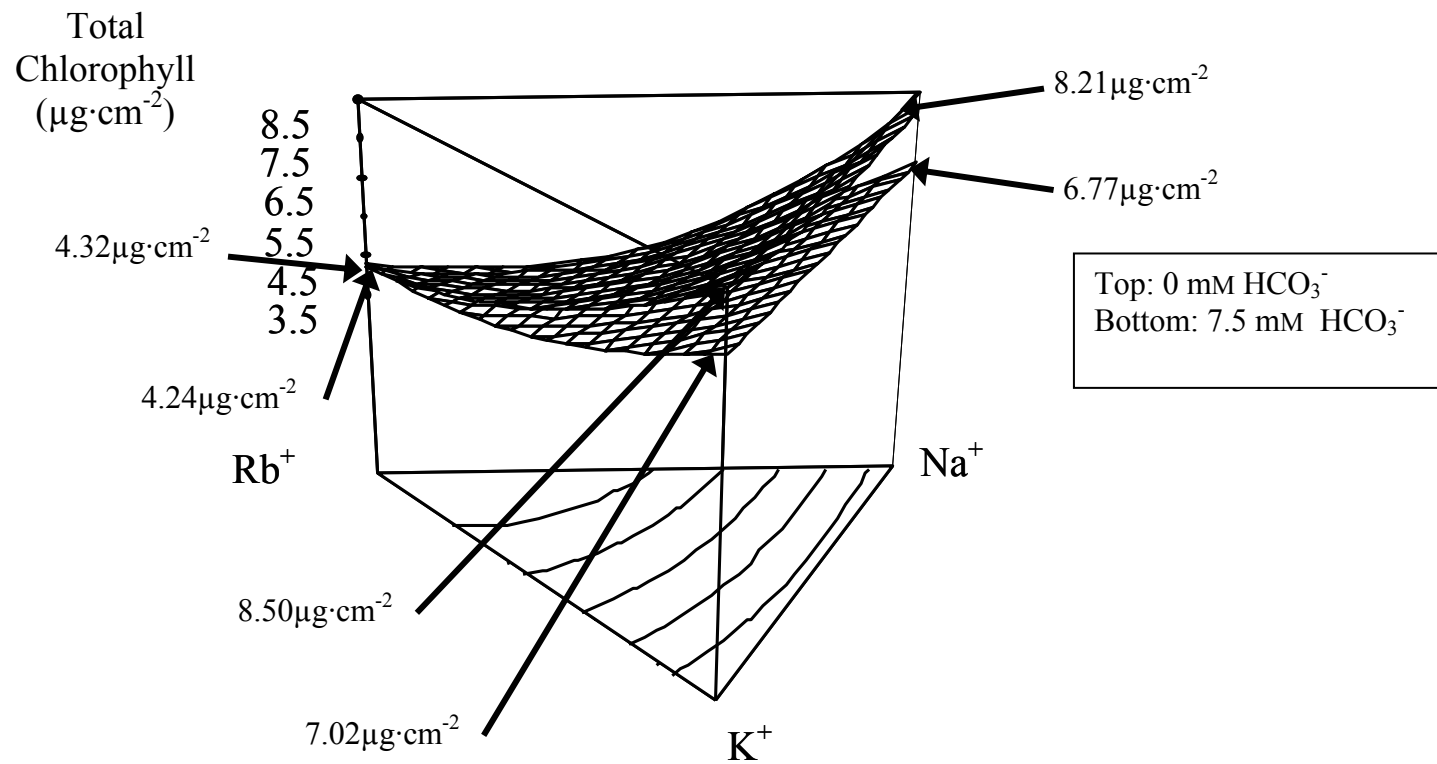

Fig. 6.22. Effect of mixtures of varying proportions of  $\text{Rb}^+$ ,  $\text{K}^+$ , and  $\text{Na}^+$  as counter-cations of  $\text{HCO}_3^-$  on total chlorophyll concentration of bean, *Phaseolus vulgaris* L. 'Poncho', grown in hydroponics with 7.5 mM total concentration and two levels of  $\text{HCO}_3^-$ .

In general, the addition of 7.5 mM  $\text{HCO}_3^-$  in the solutions increased pH (Table 6.23). This was supported by the positive coefficients of the interactions of each counter-cation with  $\text{HCO}_3^-$  in the final equation (Table 6.21).

The coefficients for the  $\text{Rb}^+$  ( $\beta_1$ ),  $\text{K}^+$  ( $\beta_2$ ), and  $\text{Na}^+$  ( $\beta_3$ ) pure blends were very similar in mixtures with  $\text{HCO}_3^-$  addition, but pH decreased in the  $\text{Rb}^+$  pure blends in mixtures with no  $\text{HCO}_3^-$  (Table 6.23). Both facts were supported by the non overlapping confidence intervals between  $\text{Rb}^+$  and  $\text{K}^+$ , and between  $\text{Rb}^+$  and  $\text{Na}^+$  (Table 6.20).

### *Discussion*

This experiment was set up in order to elucidate if the lack of  $\text{K}^+$  in the solutions of the pure blends of  $\text{Rb}^+$  and  $\text{Na}^+$  could have interfered with the response to  $\text{HCO}_3^-$  in Experiment 6.3. In order to do so, the plants were fed once a week with a solution containing 5 mM  $\text{K}^+$ .

Although shoot and root growth parameters fit a quadratic model, in general, the response to the pure blends at both levels of  $\text{HCO}_3^-$  was very similar to the results described in Experiment 6.3. This confirmed that the response to  $\text{Rb}^+$  and  $\text{Na}^+$  were not due to the lack of  $\text{K}^+$ .

Nonetheless, the difference between the growth rates of plants treated with and with no  $\text{HCO}_3^-$  was at a lesser extent compared to the results obtained in Experiment 6.3. This reduced response to  $\text{HCO}_3^-$  is appreciated by observing the proximity between both response surfaces in Fig. 6.18, implying that the addition of  $\text{K}^+$  allowed overcoming  $\text{HCO}_3^-$  toxicity. A mechanism to explain this response can not be formulated with data available. In Experiment 6.3, it was demonstrated that  $\text{K}^+$  deficiency was not affecting the response of plants when its proportion was higher than  $1/6$ , suggesting that  $\text{K}^+$  added once a week in present experiment may have affected another physiological processes. These hypothetical processes may be inhibited by the presence of  $\text{HCO}_3^-$  in solution, so once  $\text{HCO}_3^-$  is removed, the uptake of  $\text{K}^+$  may reinstate those processes.

Some authors have provided evidence indicating that  $\text{K}^+$  may contribute to decrease the severity of Fe deficiency (McCallister et al., 1989). According to McCallister et al (1989), adequate  $\text{K}^+$  supplies decrease plant P uptake, which would

decrease the potential of P to inactivate Fe inside the plant. Mengel and Kirkby (2001) indicate that phosphate is frequently considered the main cause of Fe chlorosis, but they conclude that the high P concentrations associated to Fe-chlorosis occur as the consequence of Fe deficiency and it is not the reason of Fe deficiency.

Potassium has been proven to be determinant to the function of Fe stress mechanisms. In Fe stress soybean and tomato, release of  $H^+$  and reduction of  $Fe^{3+}$  to  $Fe^{2+}$  declined in  $K^+$ -deficient plants (Hughes et al, 1992). In muskmelon,  $K^+$  deficiency did not prevent release of  $H^+$  and reduction of  $Fe^{3+}$  to  $Fe^{2+}$  but adequate levels of  $K^+$  enabled the plant to maximize  $Fe^{3+}$  reduction (Hughes et al., 1990). The role of  $K^+$  on Fe uptake may explain the response observed in bean plants on present experiment. It is probable that the  $K^+$  added once a week may have enabled the plant to reduce the Fe precipitated on root surface in plants grown in mixtures containing  $HCO_3^-$ , allowing the plants to overcome  $HCO_3^-$  toxicity. Since in present experiment the effect of  $HCO_3^-$  was neutralized, it was not possible to separate the counter-cation and  $HCO_3^-$  effects.

#### **Experiment 6.5. Response of Bean Plants to Alkalinity Induced by $NaHCO_3$ and $KHCO_3$**

##### *Shoot and root mass*

Both root and shoot dry mass decreased as the concentration of either  $KHCO_3$  or  $NaHCO_3$  increased (Table 6.24)(Fig. 6.23). The only difference between the effect of  $Na^+$  and  $K^+$  was at 0 mM  $HCO_3^-$ . This was because the 0 mM  $KHCO_3$  solution contained no  $K^+$ , thus the plants exhibited  $K^+$  deficiency. All the  $NaHCO_3$  treatments, including the 0 mM, contained 5 mM  $K^+$ , for this reason, no deficiency was observed.

ANOVA indicated that there was not a significant difference ( $P>0.05$ ) between  $NaHCO_3$  and  $KHCO_3$  (see the source effect in Table 6.24). The effect of concentration was significant ( $P\leq 0.05$ )(Table 6.24).

The interaction was significant, but this is of little importance since it was due to the difference between sources at 0 mM (Table 6.24). For the rest of the concentrations assessed in this experiment, the response to  $KHCO_3$  or  $NaHCO_3$  was comparable (Fig 6.23).



Table 6.24. Effect of the concentration of two sources of bicarbonate, NaHCO<sub>3</sub> and KHCO<sub>3</sub>, on shoot and root mass of bean, *Phaseolus vulgaris* L. ‘Poncho’, plants grown in hydroponics. Experiment 6.5.

mM	Shoot Dry Mass <sup>z</sup> (g)		Shoot Fresh Mass (g)		Root Dry Mass (g)		Root Fresh Weight (g)	
	NaHCO <sub>3</sub>	KHCO <sub>3</sub>	NaHCO <sub>3</sub>	KHCO <sub>3</sub>	NaHCO <sub>3</sub>	KHCO <sub>3</sub>	NaHCO <sub>3</sub>	KHCO <sub>3</sub>
0	13.3±0.7	6.6±0.4	154.9±5.4	78.6±3.8	2.6±0.1	1.5±0.1	55.9±2.5	35.4±1.4
2.5	9.4±1.2	9.9±0.6	119.3±10.0	125.9±6.0	1.9±0.2	1.8±0.2	40.6±4.9	38.7±2.2
5	4.9±0.7	5.7±0.9	63.0±7.5	75.5±9.6	1.3±0.2	1.6±0.3	24.8±3.9	30.5±4.5
7.5	4.1±0.3	3.1±0.1	43.3±3.6	38.1±1.1	1.4±0.1	1.1±0.1	22.6±2.6	18.2±1.0
10	3.4±0.2	4.3±0.5	37.1±1.4	49.2±5.4	1.2±0.0	1.5±0.2	16.0±0.6	22.9±4.3
15	3.8±0.3	4.0±0.3	36.4±2.2	40.7±3.9	1.6±0.1	1.8±0.1	21.2±2.8	24.5±2.5
20	2.5±0.3	3.2±0.4	19.4±1.8	27.4±3.3	1.3±0.1	1.7±0.2	13.1±1.5	17.1±3.0
25	1.3±0.0	2.1±0.1	10.9±0.8	18.9±0.8	0.6±0.0	0.9±0.1	2.9±0.5	5.8±1.1
30	1.0±0.0	1.5±0.1	8.2±1.1	16.8±1.0	0.4±0.0	0.5±0.1	2.0±0.4	2.6±0.6
Source <sup>y</sup>	NS		NS		NS		NS	
Conc. <sup>x</sup>	***		***		***		***	
Int. <sup>w</sup>	***		***		***		***	
R <sup>2</sup>	0.91		0.95		0.75		0.88	
CV (%)	23.87		19.97		25.32		27.02	

<sup>z</sup>Means ± Standard Error (n=5)

<sup>y</sup>Significance according to ANOVA; NS, \*, \*\*, \*\*\* Non-significant, significant at P≤0.05, P≤0.01 and P≤0.001, respectively

<sup>x</sup>Conc. = Concentration effect

<sup>w</sup>Int. = Interaction

R<sup>2</sup>= Coefficient of determination

CV= Coefficient of variation

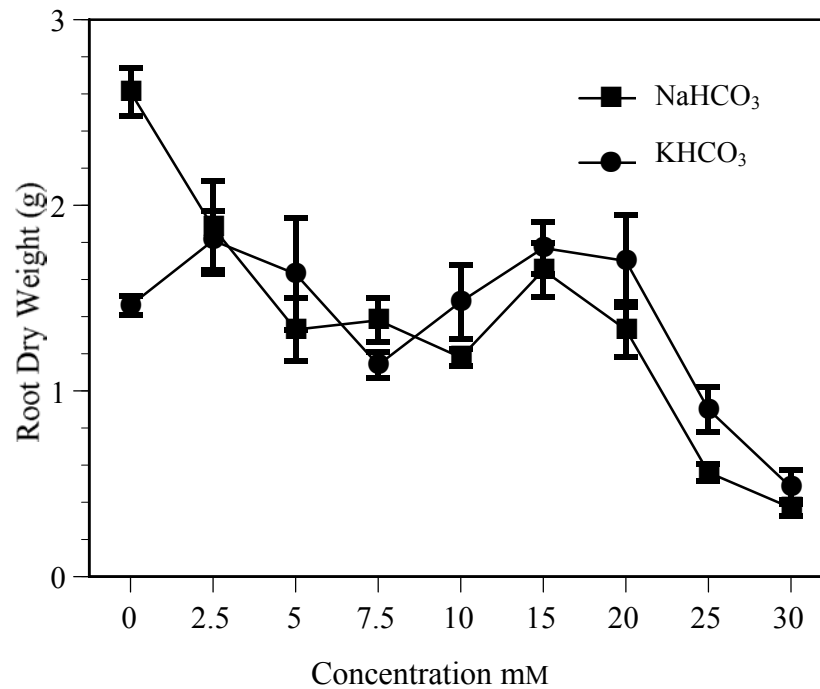
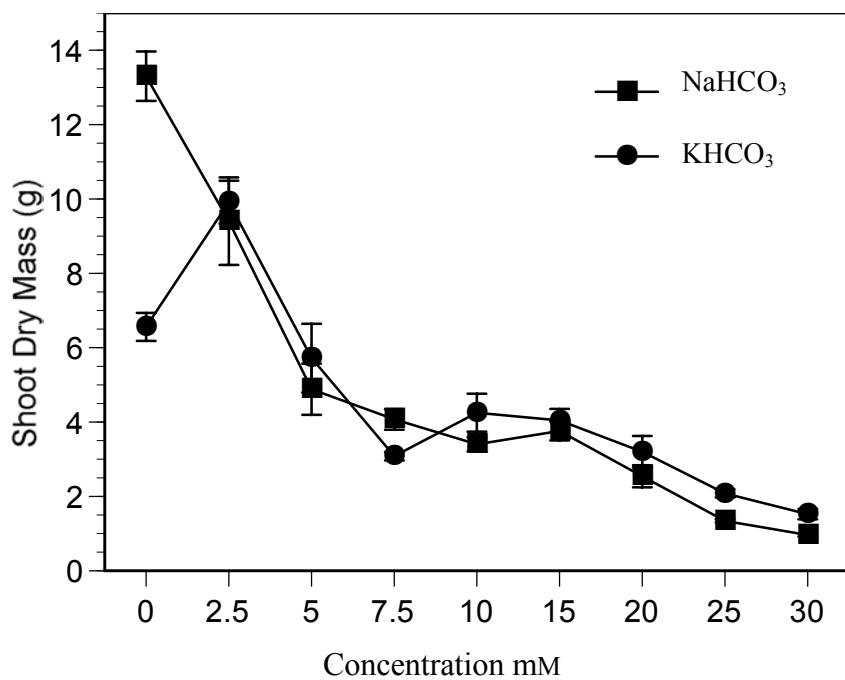

Fig. 6.23. Shoot and root dry mass at final harvest of bean, *Phaseolus vulgaris* L. 'Poncho', plants grown in hydroponics with increasing concentrations of NaHCO<sub>3</sub> and KHCO<sub>3</sub>. Bars represent standard error for the mean (n=5).

### *Leaf growth*

Leaf area, leaf dry and fresh mass behaved similar to shoot and root mass (Table 6.25).

### *Total chlorophyll*

Total chlorophyll concentration on younger leaves was significantly ( $P \leq 0.05$ ) higher in the  $\text{NaHCO}_3$  treatments ( $P \leq 0.05$ ) (Table 6.25) when the concentration of  $\text{NaHCO}_3$  was equal to or higher than 7.5 mM (Table 6.25). With 5 mM or less, the concentration of chlorophyll was higher in the  $\text{KHCO}_3$  treatments, except in the 0 mM.

### *Discussion*

The general tendency was a steep decrease in plant growth as the concentration of either  $\text{KHCO}_3$  or  $\text{NaHCO}_3$  increased from 0 to 30 mM. The typical response in growth was exhibited by the shoot dry mass decrease (Fig. 6.23).

The more severe decrease occurred as the concentration increased from 0 to 7.5 mM, after which growth reduction remained unchanged between 7.5 to 15 mM. A further decrease in shoot mass occurred at concentrations higher than 15 mM.

Comparing the effect of increasing levels of  $\text{NaHCO}_3$  and  $\text{KHCO}_3$ , there was not differential response between the sources of  $\text{HCO}_3^-$ , except in the 0 mM control treatment. Plants treated with 0 mM  $\text{NaHCO}_3$  grew in solutions containing 5 mM  $\text{K}^+$ , while plants treated with 0 mM  $\text{KHCO}_3$  did not. The  $\text{K}^+$  supplied in the 0 mM  $\text{NaHCO}_3$  solution would explain the higher total mass accumulated by these plants.

The fact that there was not difference between the  $\text{NaHCO}_3$  and  $\text{KHCO}_3$  treatments, except for the 0 mM, indicated that there was not effect of the counter-cations of  $\text{HCO}_3^-$ , suggesting that the damage induced by  $\text{Na}^+$  and  $\text{HCO}_3^-$  was not additive. Any ion may induce at least two types of toxicities, a general osmotic effect and a specific ion effect. These data indicates that both  $\text{K}^+$  and  $\text{Na}^+$  exhibited similar osmotic effects and there was not an additional specific  $\text{Na}^+$  or  $\text{K}^+$  ion effect.

Table 6.25. Effect of the concentration of two sources of bicarbonate, NaHCO<sub>3</sub> and KHCO<sub>3</sub>, on leaf area, leaf dry and fresh mass, final solution pH, and total chlorophyll concentration of bean, *Phaseolus vulgaris* L. 'Poncho', plants grown in hydroponics. Experiment 6.5.

mM	Leaf Area <sup>z</sup> (cm <sup>2</sup> )		Leaf Dry Weight (g)		Leaf Fresh Weight (g)		Solution pH		Total Chlorophyll (µg·cm <sup>-2</sup> )	
	NaHCO <sub>3</sub>	KHCO <sub>3</sub>	NaHCO <sub>3</sub>	KHCO <sub>3</sub>	NaHCO <sub>3</sub>	KHCO <sub>3</sub>	NaHCO <sub>3</sub> <sup>-</sup>	KHCO <sub>3</sub> <sup>-</sup>	NaHCO <sub>3</sub> <sup>-</sup>	KHCO <sub>3</sub> <sup>-</sup>
0	3652±100	2190±95	8.7±0.3	5.6±0.1	71.9±1.5	40.7±1.4	6.36±0.09	6.34±0.16	15.2±0.8	11.6±0.2
2.5	3172±120	3147±246	6.9±0.6	7.1±0.4	56.9±3.9	56.9±3.9	7.51±0.04	7.57±0.06	13.9±0.5	14.4±0.4
5	1991±211	2297±250	3.9±0.5	4.7±0.6	38.2±3.9	45.2±5.0	7.90±0.02	7.94±0.04	12.1±0.6	12.4±0.6
7.5	1142±97	1085±42	3.1±0.2	2.4±0.1	26.9±2.5	23.5±0.6	8.23±0.02	8.33±0.06	11.3±0.4	10.6±0.2
10	1026±44	987±204	2.4±0.1	3.0±0.4	22.6±0.7	30.2±3.7	8.25±0.06	8.05±0.03	11.0±0.4	10.9±0.7
15	1058±35	1074±113	2.4±0.1	2.5±0.2	22.3±1.6	25.0±2.4	8.30±0.05	8.30±0.03	10.9±0.3	9.8±0.9
20	509±51	648±94	1.3±0.1	1.7±0.2	11.5±1.1	16.5±1.9	8.48±0.03	8.55±0.03	8.9±0.3	8.3±0.3
25	287±25	434±22	0.8±0.1	1.3±0.1	6.2±0.6	11.5±0.5	8.79±0.04	8.77±0.02	9.9±0.6	7.6±0.9
30	214±47	372±13	0.5±0.1	1.2±0.1	3.6±0.8	9.9±0.5	8.90±0.04	8.90±0.02	10.4±0.5	7.0±1.2
Source <sup>y</sup>	NS		NS		NS		NS		***	
Conc. <sup>x</sup>	***		***		***		***		***	
Int. <sup>w</sup>	**		***		***		NS		**	
R <sup>2</sup>	0.95		0.94		0.94		0.98		0.77	
CV (%)	20.01		20.26		19.15		1.57		12.25	

<sup>z</sup>Means ± Standard Error (n=5)

<sup>y</sup>Significance according to ANOVA; NS, \*, \*\*, \*\*\* Non-significant, significant at P≤0.05, P≤0.01 and P≤0.001, respectively

<sup>x</sup>Conc. = Concentration effect

<sup>w</sup>Int. = Interaction

R<sup>2</sup>= Coefficient of determination

CV= Coefficient of variation

## Experiment 6.6. Effect of $K^+ : Na^+$ Binary Mixtures on the Response of Bean Plants to $HCO_3^-$

### *Shoot mass*

#### 2.5 mM total mixture

*Models.* A 2.5 mM  $K^+ + Na^+$  total mixture significantly affected ( $P \leq 0.05$ ) shoot dry mass in plants with no  $HCO_3^-$ , according to ANOVA (Table 6.26). The best fit for both shoot dry and fresh mass in response to the  $K^+ : Na^+$  mixtures was a quadratic model (Table 6.27). The final equation is presented in Table 6.28.

*0 mM  $HCO_3^-$ .* According to the models, as the proportion of  $Na^+$  in the mixtures increased, shoot dry and fresh mass decreased, especially at proportions above  $1/2 Na^+$  (Fig. 6.24A). In the  $Na^+$  pure blend (coefficient  $\beta_2$  in Table 6.27), shoot dry and fresh mass decreased 47% and 59%, respectively, compared to the  $K^+$  pure blend (coefficient  $\beta_1$ ).

In mixtures containing no  $HCO_3^-$ , the model predicted that the maximum shoot dry mass, 4.75 g, occurred at the  $3/4 : 1/4 K^+ : Na^+$  mixture (Table 6.29). The confidence interval for this prediction did not overlap with the intervals of the mixtures  $1/4 : 3/4$  and 0:1 (Table 6.29), indicating a significant difference.

*2.5 mM  $HCO_3^-$ .* According to the models, the tendency in plant response to the mixtures of different proportions of  $K^+ : Na^+$  followed the same tendency as plants treated with no  $HCO_3^-$  (Fig. 6.24A). As the proportion of  $Na^+$  in the mixtures increased above  $1/2$ , shoot dry mass decreased (Fig. 6.24A). In the  $Na^+$  pure blend (coefficient  $\beta_2$  in Table 6.27), shoot dry mass decreased 55% compared to the  $K^+$  pure blend (coefficient  $\beta_1$ ). The maximum shoot dry mass was predicted to occur in the 1:0 and  $3/4 : 1/4$  mixtures (Table 6.29). The confidence intervals did not overlap with the intervals of the mixtures  $1/4 : 3/4$  and 0:1 (Table 6.29), indicating a significant decrease with increasing proportions of  $Na^+$ .

*General Effect of  $HCO_3^-$ .* Bicarbonate caused a decrease in shoot dry mass in all the mixtures (Table 6.27) (Fig. 6.24A). This was denoted by the separation between the

Table 6.26. Effect of mixtures of varying proportions of K<sup>+</sup> and Na<sup>+</sup> counter-cations of HCO<sub>3</sub><sup>-</sup> on shoot and root mass of bean, *Phaseolus vulgaris* L. 'Poncho', plants in a 2.5 mM total concentration and two levels of HCO<sub>3</sub><sup>-</sup>. Experiment 6.6.

Mixture K <sup>+</sup> :Na <sup>+</sup>	Shoot Dry Mass <sup>z</sup> (g)		Shoot Fresh Mass (g)		Root Dry Mass (g)		Root Fresh Weight (g)	
	2.5 mM Total Mixture							
	HCO <sub>3</sub> <sup>-</sup> (mM)		HCO <sub>3</sub> <sup>-</sup> (mM)		HCO <sub>3</sub> <sup>-</sup> (mM)		HCO <sub>3</sub> <sup>-</sup> (mM)	
	0	2.5	0	2.5	0	2.5	0	2.5
1:0	4.37ab	3.02	37.4a	26.9	0.79a	0.90	20.6a	15.4
<sup>3</sup> / <sub>4</sub> : <sup>1</sup> / <sub>4</sub>	4.75a	3.30	40.9a	27.5	0.80a	0.67	22.4a	13.9
<sup>1</sup> / <sub>2</sub> : <sup>1</sup> / <sub>2</sub>	4.73a	3.43	36.6a	27.6	0.83a	0.67	19.6ab	15.0
<sup>1</sup> / <sub>4</sub> : <sup>3</sup> / <sub>4</sub>	3.63b	3.01	27.7b	25.7	0.62b	0.76	15.5b	15.4
0:1	2.36c	2.12	15.9c	21.5	0.42c	0.41	9.9c	13.3
Significance <sup>y</sup>	***	NS	***	NS	***	NS	***	NS
R <sup>2</sup>	0.80	0.27	0.83	0.14	0.75	0.12	0.74	0.02
CV%	13.04	29.33	14.73	24.72	14.97	35.55	17.68	46.78

<sup>z</sup>Means followed by the same letter indicates non-significant difference according to the LSD multiple comparison test at  $P \leq 0.05$

<sup>y</sup>Significance according to ANOVA, NS, \*, \*\*, \*\*\* Non significant, and significant at  $P \leq 0.05$ ,  $P \leq 0.01$ , and  $P \leq 0.001$ , respectively

R<sup>2</sup>= Coefficient of determination

CV= Coefficient of variation

Table 6.27. Models<sup>z</sup> for the shoot and root mass, shoot:root ratio, and leaf area of bean, *Phaseolus vulgaris* L. ‘Poncho’, plants in response to K<sup>+</sup>:Na<sup>+</sup> mixtures with a 2.5 mM total concentration combined with two concentrations of HCO<sub>3</sub><sup>-</sup>. Experiment 6.6.

Coefficient <sup>y</sup>	Shoot Dry Mass (g)		Shoot Fresh Mass (g)		Root Dry Mass (g)		Root Fresh Mass (g)		Shoot:Root Ratio (g/g <sup>-1</sup> )		Leaf Area (cm <sup>2</sup> )	
	2.5 mM Total Mixture											
	HCO <sub>3</sub> <sup>-</sup> (mM)		HCO <sub>3</sub> <sup>-</sup> (mM)		HCO <sub>3</sub> <sup>-</sup> (mM)		HCO <sub>3</sub> <sup>-</sup> (mM)		HCO <sub>3</sub> <sup>-</sup> (mM)		HCO <sub>3</sub> <sup>-</sup> (mM)	
	0	2.5	0	2.5	0	2.5	0	2.5	0	2.5	0	2.5
Slack var.	-	-	-	-	-	-	-	-	5.89	4.53	-	-
β <sub>1</sub>	+4.55	+3.85	+37.86	+23.71	+0.83	+0.49	+23.82	+18.39	-0.27	-0.01	+1321	+1056
β <sub>2</sub>	+2.39	+1.74	+15.43	+20.20	+0.42	+1.03	+11.61	+13.81	-	-	+559	+498
β <sub>3</sub>	+3.93	+2.82	+40.14	+22.59	+0.54	-0.16	-	-	-	-	+1121	+667
Model	Quadratic		Quadratic		Quadratic		Linear		Modified		Quadratic	
Lack of fit <sup>x</sup>	P=0.768		P=0.984		P=0.081		P=0.892		P=0.378		P=0.431	
Adeq. Prec.	10.70		12.19		8.50		7.31		4.77		10.70	
R <sup>2</sup>	0.65		0.72		0.51		0.33		0.34		0.69	
CV%	19.87		17.55		8.50		30.66		17.41		20.36	

<sup>z</sup>To estimate any parameter, multiply the coefficients indicated in the table by the proportion of the corresponding counter-ion in the mixture of interest

<sup>y</sup>β<sub>1</sub>: K<sup>+</sup>, β<sub>2</sub>: Na<sup>+</sup>, β<sub>3</sub>: Na<sup>+</sup>\*K<sup>+</sup>

<sup>x</sup>Lack of fit according to ANOVA

Adeq. Prec.=Adequate precision

R<sup>2</sup>= Coefficient of determination

CV= Coefficient of variation

Table 6.28. Final equation for the growth parameters of bean, *Phaseolus vulgaris* L. ‘Poncho’, plants in response to K<sup>+</sup>:Na<sup>+</sup> mixtures with a 2.5 mM total concentration combined with two concentrations of HCO<sub>3</sub><sup>-</sup>. Experiment 6.6.

Parameter	Final equation <sup>z</sup>
Shoot Dry Mass (g)	$4.20K + 2.07Na + 3.38K*Na - 0.35K*HCO_3^- - 0.32Na*HCO_3^- - 0.55K*Na*HCO_3^-$
Shoot Fresh Mass (g)	$35.95K + 18.52Na + 18.37K*Na - 3.21K*HCO_3^- + 2.48Na*HCO_3^- - 13.18K*Na*HCO_3^-$
Root Dry Mass (g)	$0.93K + 0.46Na + 0.19K*Na + 0.10K*HCO_3^- + 0.03Na*HCO_3^- - 0.35K*Na*HCO_3^-$
Root Fresh Mass (g)	$21.11K + 12.71Na - 2.72K*HCO_3^- + 1.10Na*HCO_3^-$
Leaf Dry Mass (g)	$2.59K + 1.30Na + 1.95K*Na - 0.24K*HCO_3^- - 0.20Na*HCO_3^- - 0.26K*Na*HCO_3^-$
Leaf Fresh Mass (g)	$22.73K + 10.27Na + 14.74K*Na - 2.24K*HCO_3^- + 0.77Na*HCO_3^- - 5.58K*Na*HCO_3^-$
Leaf Area (cm <sup>2</sup> )	$1188.7K + 528.3Na + 894.2K*Na - 132.6K*HCO_3^- - 30.2Na*HCO_3^- - 226.8K*Na*HCO_3^-$
Water consumption (ml·plant <sup>-1</sup> )	$2276.54K + 1404.26Na - 225.7K*HCO_3^- - 304.85Na*HCO_3^-$
Shoot:Root Ratio (g·g <sup>-1</sup> )	$5.21 - 0.14K - 0.68HCO_3^- + 0.13K*HCO_3^-$
Solution pH	$6.73K + 7.20Na + 0.88K*HCO_3^- + 0.38Na*HCO_3^-$
Total Chlorophyll (µg·cm <sup>-2</sup> )	$10.01K + 11.29Na - 0.16K*HCO_3^- - 1.64Na*HCO_3^-$

<sup>z</sup>To estimate the response, the counter-ions must be expressed in terms of their proportion in the mixture of interest and HCO<sub>3</sub><sup>-</sup> takes a -1 or +1 value at a concentration of 0 and 2.5 mM, respectively



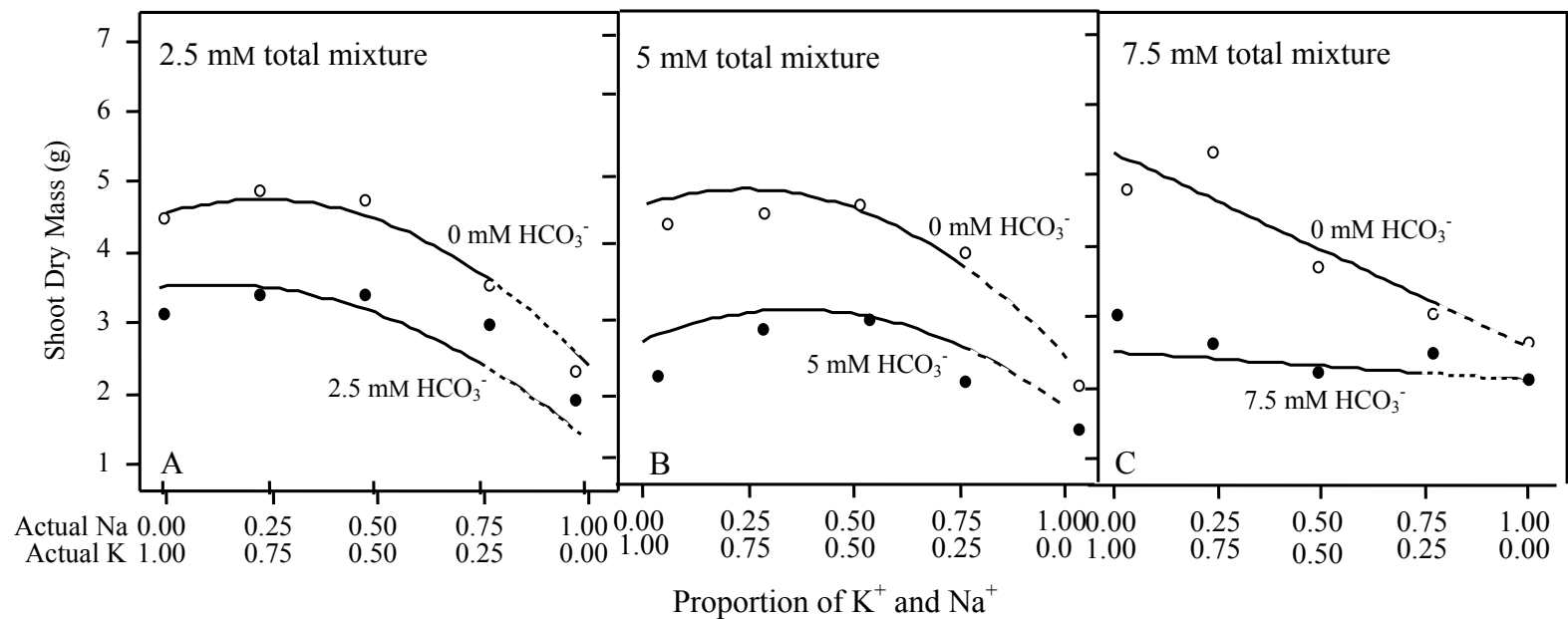

Fig. 6.24. Effect of 2.5, 5, and 7.5 mM total mixtures of varying K<sup>+</sup> and Na<sup>+</sup> proportions at two levels of HCO<sub>3</sub><sup>-</sup> on shoot dry mass of bean, *Phaseolus vulgaris* L. 'Poncho', plants. Open symbols=0 mM HCO<sub>3</sub><sup>-</sup>. Closed symbols=2.5, 5, or 7.5 mM HCO<sub>3</sub><sup>-</sup>. Dashed portion indicates a region of a probable K<sup>+</sup> deficiency effect.

Table 6.29. Predicted response and 95% confidence interval for shoot mass, root mass, and leaf area of bean, *Phaseolus vulgaris* L. ‘Poncho’, plants grown in mixtures of varying proportions of K<sup>+</sup> and Na<sup>+</sup> counter-cations of HCO<sub>3</sub><sup>-</sup> with a 2.5 mM total concentration and two concentrations of HCO<sub>3</sub><sup>-</sup>. Experiment 6.6.

Mixtures K <sup>+</sup> -Na <sup>+</sup>	Shoot Dry Mass (g)			Root Dry Mass (g)			Leaf Area (cm <sup>2</sup> )		
	CI <sub>L</sub> <sup>z</sup>	CI <sub>H</sub> <sup>y</sup>	CI <sub>L</sub>	CI <sub>H</sub>	CI <sub>L</sub>	CI <sub>H</sub>			
					0 mM HCO <sub>3</sub> <sup>-</sup>				
1:0	3.93	4.55	5.17	0.67	0.83	0.99	1147	1231	1496
<sup>3</sup> / <sub>4</sub> : <sup>1</sup> / <sub>4</sub>	4.33	4.75	5.17	0.73	0.83	0.94	1224	1342	1460
<sup>1</sup> / <sub>2</sub> : <sup>1</sup> / <sub>2</sub>	3.97	4.45	4.95	0.64	0.76	0.89	1081	1220	1360
<sup>1</sup> / <sub>4</sub> : <sup>3</sup> / <sub>4</sub>	3.25	3.70	4.13	0.52	0.63	0.74	844	968	1093
0:1	1.70	2.39	3.08	0.25	0.42	0.60	365	559	752
					2.5 mM HCO <sub>3</sub> <sup>-</sup>				
1:0	3.15	3.85	4.55	0.85	1.02	1.20	859	1056	1253
<sup>3</sup> / <sub>4</sub> : <sup>1</sup> / <sub>4</sub>	3.38	3.85	4.33	0.75	0.87	0.98	910	1043	1176
<sup>1</sup> / <sub>2</sub> : <sup>1</sup> / <sub>2</sub>	2.97	3.50	4.04	0.58	0.71	0.85	795	943	1093
<sup>1</sup> / <sub>4</sub> : <sup>3</sup> / <sub>4</sub>	2.36	2.82	3.29	0.48	0.60	0.71	638	768	899
0:1	0.96	1.74	2.53	0.29	0.49	0.69	277	498	719

<sup>z</sup>CI<sub>L</sub>=low confidence interval

<sup>y</sup>CI<sub>H</sub>=high confidence interval

0 mM  $\text{HCO}_3^-$  and the 2.5 mM  $\text{HCO}_3^-$  lines in Fig. 6.24A. Using the  $\text{K}^+$  pure blend, 1:0 mixture, with no  $\text{HCO}_3^-$ , as the reference point (coefficient  $\beta_1$  in Table 6.27), there was a more severe inhibition when  $\text{HCO}_3^-$  was blended with  $\text{Na}^+$  (coefficient  $\beta_2$ ) as the counter-cation (Table 6.27).

Comparing the effect of  $\text{HCO}_3^-$  at both  $\text{K}^+$  and  $\text{Na}^+$  vertices, the growth decrease induced by  $\text{HCO}_3^-$  was proportionally higher in the  $\text{Na}^+$  vertex (Table 6.27)(Fig. 6.24A). In the  $\text{K}^+$  vertex, shoot dry mass decreased by 15% by the addition of 2.5 mM  $\text{HCO}_3^-$  (compare  $\beta_1$  coefficients in Table 6.27). In the  $\text{Na}^+$  vertex, the decrease was of 27%. This indicates that the use of 2.5 mM  $\text{HCO}_3^-$  was more detrimental for shoot mass when it was added to mixtures containing  $\text{Na}^+$ .

#### 5 mM total mixture

*Models.* Total mixtures of 5 mM significantly affected ( $P \leq 0.05$ ) dry and fresh mass of shoots in plants treated without  $\text{HCO}_3^-$  according to ANOVA (Table 6.30). a quadratic model was the best fit for the shoot dry mass response at both concentrations of  $\text{HCO}_3^-$ , while a linear model fit the shoot fresh mass (Table 6.31). The final equations are presented in Table 6.32.

*0 mM  $\text{HCO}_3^-$ .* Similar to the results with the 2.5 mM total mixture, the model indicated that as the proportion of  $\text{Na}^+$  increased, the shoot dry and fresh mass decreased, especially at proportions above  $1/2 \text{Na}^+$  (Fig. 6.24B). In the  $\text{Na}^+$  pure blend (coefficient  $\beta_2$  in Table 6.31), shoot dry mass decreased by 41% compared to the  $\text{K}^+$  pure blend (coefficient  $\beta_1$ ).

The model predicted the maximum shoot dry mass, 4.84 g, to occur at the  $3/4:1/4 \text{K}^+:\text{Na}^+$  mixture (Table 6.33). The confidence interval for this prediction did not overlap with the interval of the 0:1 mixture (Table 6.33), indicating a significant difference.

*5 mM  $\text{HCO}_3^-$ .* The detrimental effect of  $\text{HCO}_3^-$  increased as the proportion of  $\text{Na}^+$  increased (Fig. 6.24B). In the  $\text{Na}^+$  pure blend (coefficient  $\beta_2$  in Table 6.31), shoot dry mass decreased by 43% compared to the  $\text{K}^+$  pure blend (coefficient  $\beta_1$ )(Fig. 6.24B).

Table 6.30. Effect of mixtures of varying proportions of K<sup>+</sup> and Na<sup>+</sup> counter-cations of HCO<sub>3</sub><sup>-</sup> on shoot and root mass of bean, *Phaseolus vulgaris* L. 'Poncho', plants in a 5 mM total concentration and two levels of HCO<sub>3</sub><sup>-</sup>. Experiment 6.6.

Mixture K <sup>+</sup> -Na <sup>+</sup>	Shoot Dry Mass <sup>z</sup> (g)		Shoot Fresh Mass (g)		Root Dry Mass (g)		Root Fresh Weight (g)	
	5 mM Total Mixture							
	HCO <sub>3</sub> <sup>-</sup> (mM)		HCO <sub>3</sub> <sup>-</sup> (mM)		HCO <sub>3</sub> <sup>-</sup> (mM)		HCO <sub>3</sub> <sup>-</sup> (mM)	
	0	5	0	5	0	5	0	5
1:0	4.49a	2.56	36.5a	25.8	0.77ab	0.91a	20.3ab	20.5a
<sup>3</sup> / <sub>4</sub> : <sup>1</sup> / <sub>4</sub>	4.46a	2.94	37.2a	27.6	0.83a	0.87ab	19.6ab	19.4ab
<sup>1</sup> / <sub>2</sub> : <sup>1</sup> / <sub>2</sub>	4.68a	2.99	38.8a	27.5	0.83a	0.89ab	21.5a	15.3abc
<sup>1</sup> / <sub>4</sub> : <sup>3</sup> / <sub>4</sub>	4.19a	2.25	35.0a	18.2	0.65b	0.63bc	16.7b	10.5bc
0:1	2.08b	2.14	14.0b	19.4	0.35b	0.45c	8.1c	7.3c
Significance <sup>y</sup>	***	NS	***	NS	***	*	***	*
R <sup>2</sup>	0.75	0.208	0.81	0.27	0.80	0.56	0.77	0.48
CV%	16.28	31.16	15.90	32.36	15.56	24.94	17.89	41.56

<sup>z</sup>Means followed by the same letter indicates non significant difference according to the LSD multiple comparison test at  $P \leq 0.05$

<sup>y</sup>Significance according to ANOVA, NS, \*, \*\*, \*\*\* non significant, and significant at  $P \leq 0.05$ ,  $P \leq 0.01$ , and  $P \leq 0.001$ , respectively

R<sup>2</sup>= Coefficient of determination

CV= Coefficient of variation

Table 6.31. Models<sup>z</sup> for the shoot and root mass, shoot:root ratio, and leaf area of bean, *Phaseolus vulgaris* L. ‘Poncho’, plants in response to a 5 mM mixture of varying proportions of K<sup>+</sup> and Na<sup>+</sup> combined with two concentrations of HCO<sub>3</sub><sup>-</sup>. Experiment 6.6.

Coefficient <sup>x</sup>	Shoot Dry Mass		Shoot Fresh Mass		Root Dry Mass		Root Fresh Mass		Shoot:Root Ratio <sup>y</sup>		Leaf Area				
	(g)		(g)		(g)		(g)		(g/g <sup>-1</sup> )		(cm <sup>2</sup> )				
	5 mM Total Mixture														
	HCO <sub>3</sub> <sup>-</sup> (mM)		HCO <sub>3</sub> <sup>-</sup> (mM)		HCO <sub>3</sub> <sup>-</sup> (mM)		HCO <sub>3</sub> <sup>-</sup> (mM)		HCO <sub>3</sub> <sup>-</sup> (mM)		HCO <sub>3</sub> <sup>-</sup> (mM)				
0		5		0		5		0		5		0		5	
Slack var.									+6.37	+4.47					
β <sub>1</sub>	+4.63	+2.75	+46.56	+29.34	+0.81	+0.88	+21.10	+19.64	-1.98	-2.81	+1509	+870			
β <sub>2</sub>	+2.59	+1.83	+21.98	+18.89	+0.43	+0.43	+9.98	+6.46	+1.36	+1.63	+711	+578			
β <sub>3</sub>	+3.83	+3.24	-	-	+0.83	+0.87	+19.41	+12.52	-	-	-	-			
Model	Quadratic		Linear		Quadratic		Quadratic		Modified		Linear				
Lack of fit <sup>w</sup>	P=0.235		P=0.235		P=0.432		P=0.291		P=0.464		P=0.228				
Adeq. Prec.	9.25		9.03		8.46		8.28		10.93		8.85				
R <sup>2</sup>	0.58		0.42		0.53		0.51		0.71		0.43				
CV%	26.39		35.68		23.94		31.97		16.89		38.59				

<sup>z</sup>To estimate any parameter, multiply the coefficients indicated in the table by the proportion of the corresponding counter-ion in the mixture of interest

<sup>y</sup>β<sub>1</sub>: K<sup>+</sup>, β<sub>2</sub>: K<sup>+2</sup>

<sup>x</sup>β<sub>1</sub>: K<sup>+</sup>, β<sub>2</sub>: Na<sup>+</sup>, β<sub>3</sub>: Na<sup>+</sup>\*K<sup>+</sup>

<sup>w</sup>Lack of fit according to ANOVA

Adeq. Prec.=Adequate precision

R<sup>2</sup>= Coefficient of determination

CV= Coefficient of variation

Table 6.32. Final equation for the growth parameters of bean, *Phaseolus vulgaris* L. ‘Poncho’, plants in response to K<sup>+</sup>:Na<sup>+</sup> mixtures with a 5 mM total concentration combined with two concentrations of HCO<sub>3</sub><sup>-</sup>. Experiment 6.6.

Parameter	Final equation <sup>z</sup>
Shoot Dry Mass (g)	$3.39K + 2.23Na + 3.54K*Na - 0.94K*HCO_3^- - 0.36Na*HCO_3^- - 0.30K*Na*HCO_3^-$
Shoot Fresh Mass (g)	$37.95K + 20.44Na - 8.60K*HCO_3^- - 1.54Na*HCO_3^-$
Root Dry Mass (g)	$0.85K + 0.41Na + 0.85K*Na + 0.03K*HCO_3^- + 0.02Na*HCO_3^- - 0.02K*Na*HCO_3^-$
Root Fresh Mass (g)	$20.35K + 8.22Na + 15.97K*Na - 0.70K*HCO_3^- - 1.76Na*HCO_3^- - 3.44K*Na*HCO_3^-$
Leaf Dry Mass (g)	$2.24K + 1.37Na + 2.04K*Na - 0.56K*HCO_3^- - 0.24Na*HCO_3^- - 0.25K*Na*HCO_3^-$
Leaf Fresh Mass (g)	$19.95K + 10.57Na + 21.58K*Na - 3.70K*HCO_3^- - 0.17Na*HCO_3^- - 4.85K*Na*HCO_3^-$
Leaf Area (cm <sup>2</sup> )	$1190K + 646Na - 319K*HCO_3^- - 665Na*HCO_3^-$
Water consumption (ml·plant <sup>-1</sup> )	$1598.4 + 582K - 364.4HCO_3^- - 86.4K*HCO_3^-$
Shoot:Root Ratio (g·g <sup>-1</sup> )	$5.42 - 2.42K + 0.95HCO_3^- - 1.49HCO_3^{-2} - 0.43K*HCO_3^- + 0.14K*HCO_3^- - 0.30K*95HCO_3^{-2}$
Solution pH	$7.28K + 7.26Na + 0.69K*HCO_3^- + 0.52Na*HCO_3^-$
Total Chlorophyll (μg·cm <sup>-2</sup> )	$10.06K + 9.96Na - 0.51K*HCO_3^- - 1.31Na*HCO_3^-$

<sup>z</sup>To estimate the response, the counter-ions must be expressed in terms of their proportion in the mixture of interest and HCO<sub>3</sub><sup>-</sup> takes a -1 or +1 value at a concentration of 0 and 5 mM, respectively

Table 6.33. Predicted response and 95% confidence interval for shoot mass, root mass, and leaf area of bean, *Phaseolus vulgaris* L. 'Poncho', plants grown in mixtures of varying proportions of K<sup>+</sup> and Na<sup>+</sup> counter-cations of HCO<sub>3</sub><sup>-</sup> with a 5 mM total concentration and two concentrations of HCO<sub>3</sub><sup>-</sup>. Experiment 6.6.

Mixtures K <sup>+</sup> :Na <sup>+</sup>	Shoot Dry Mass (g)			Root Dry Mass (g)			Leaf Area (cm <sup>2</sup> )		
	CI <sub>L</sub> <sup>z</sup>		CI <sub>H</sub> <sup>y</sup>	CI <sub>L</sub>		CI <sub>H</sub>	CI <sub>L</sub>	CI <sub>H</sub>	
0 mM HCO <sub>3</sub> <sup>-</sup>									
1:0	3.86	4.63	5.40	0.74	0.84	0.95	1258	1509	1761
<sup>3</sup> / <sub>4</sub> : <sup>1</sup> / <sub>4</sub>	4.34	4.84	5.34	0.83	0.90	0.96	1137	1315	1494
<sup>1</sup> / <sub>2</sub> : <sup>1</sup> / <sub>2</sub>	3.99	4.57	5.15	0.76	0.84	0.92	960	1110	1261
<sup>1</sup> / <sub>4</sub> : <sup>3</sup> / <sub>4</sub>	3.32	3.85	4.37	0.62	0.69	0.76	725	916	1107
0:1	1.74	2.59	3.44	0.31	0.42	0.53	437	711	985
5 mM HCO <sub>3</sub> <sup>-</sup>									
1:0	1.98	2.75	3.52	0.74	0.84	0.95	615	871	1127
<sup>3</sup> / <sub>4</sub> : <sup>1</sup> / <sub>4</sub>	2.62	3.13	3.64	0.85	0.89	0.96	616	800	983
<sup>1</sup> / <sub>2</sub> : <sup>1</sup> / <sub>2</sub>	2.53	3.12	3.70	0.76	0.84	0.92	578	724	871
<sup>1</sup> / <sub>4</sub> : <sup>3</sup> / <sub>4</sub>	2.21	2.71	3.21	0.62	0.69	0.76	478	653	829
0:1	1.09	1.86	2.63	0.31	0.42	0.53	329	578	827

<sup>z</sup>CI<sub>L</sub>=low confidence interval

<sup>y</sup>CI<sub>H</sub>=high confidence interval

The maximum predicted shoot dry mass, was in the  $3/4:1/4$  and  $1/2:1/2$  mixtures, 3.13 and 3.12 g, respectively (Table 6.33), but the confidence intervals overlapped with the interval of the mixture 0:1 (Table 6.33).

*General Effect of  $\text{HCO}_3^-$ .* The effect of  $\text{HCO}_3^-$  is represented by the difference in shoot mass between the 0 to 5 mM  $\text{HCO}_3^-$  treatments at each proportion. This is visualized by the separation between lines in Fig. 6.24B. There was a greater effect of  $\text{HCO}_3^-$  at 5 mM (Fig. 6.24B) compared to the 2.5 mM total mixture (Fig. 6.24A).

The non parallel curves in Fig. 6.24B indicated that the inhibition of shoot growth was not proportionally similar in both vertices,  $\text{K}^+$  and  $\text{Na}^+$ . In the  $\text{K}^+$  vertex, shoot dry mass was decreased 41% by the addition of  $\text{HCO}_3^-$  (compare  $\beta_1$  coefficients in Table 6.31). In the  $\text{Na}^+$  vertex, the decrease was 15%. This indicates that 5 mM  $\text{HCO}_3^-$  was more detrimental for shoot mass when it was added to mixtures containing only  $\text{K}^+$ .

#### 7.5 mM total mixture

*Models.* ANOVA indicates that 7.5 mM total mixtures affected significantly ( $P \leq 0.05$ ) shoot dry and fresh mass in plants treated with no  $\text{HCO}_3^-$  (Table 6.34), but there was not a significant difference between mixtures of plants grown with  $\text{HCO}_3^-$  (Table 6.34). At both concentrations of  $\text{HCO}_3^-$ , the best fit was a linear model (Table 6.35). The final equation is presented in Table 6.36.

*0 mM  $\text{HCO}_3^-$ .* Similar to the 2.5 and 5 mM total mixtures, the selected model showed that as the proportion of  $\text{Na}^+$  increased shoot mass decreased (Fig. 6.24C). In the  $\text{Na}^+$  pure blend (coefficient  $\beta_2$  in Table 6.31), shoot dry mass decreased 52% compared to the  $\text{K}^+$  pure blend (coefficient  $\beta_1$ ).

The maximum shoot dry mass, 5.53 g, was predicted to occur in the 1:0  $\text{K}^+:\text{Na}^+$  mixture (Table 6.37) (Fig. 6.24C), indicating the even the lowest proportion of  $\text{Na}^+$  caused a decrease in shoot dry mass. The confidence interval for the prediction in this mixture did not overlap with the intervals of the mixtures  $1/2:1/2$ ,  $1/4:3/4$ , and 0:1, demonstrating that there was a significant decrease with proportions of  $\text{Na}^+$  higher than  $1/2$ .



Table 6.34. Effect of mixtures of varying proportions of K<sup>+</sup> and Na<sup>+</sup> counter-cations of HCO<sub>3</sub><sup>-</sup> on shoot and root mass of bean, *Phaseolus vulgaris* L. ‘Poncho’, plants in a 7.5 mM total concentration and two levels of HCO<sub>3</sub><sup>-</sup>. Experiment 6.6.

Mixtures K <sup>+</sup> :Na <sup>+</sup>	Shoot Dry Mass <sup>z</sup> (g)		Shoot Fresh Mass (g)		Root Dry Mass (g)		Root Fresh Weight (g)	
	7.5 mM Total Mixture							
	HCO <sub>3</sub> <sup>-</sup> (mM)		HCO <sub>3</sub> <sup>-</sup> (mM)		HCO <sub>3</sub> <sup>-</sup> (mM)		HCO <sub>3</sub> <sup>-</sup> (mM)	
	0	7.5	0	7.5	0	7.5	0	7.5
1:0	4.89ab	3.16	39.0ab	28.3	0.84ab	1.11a	21.7ab	19.5a
<sup>3</sup> / <sub>4</sub> : <sup>1</sup> / <sub>4</sub>	5.50a	2.86	44.3a	26.0	1.04a	1.16a	25.2a	19.7a
<sup>1</sup> / <sub>2</sub> : <sup>1</sup> / <sub>2</sub>	3.94bc	2.35	32.9b	20.1	0.69b	1.03a	16.2c	16.6a
<sup>1</sup> / <sub>4</sub> : <sup>3</sup> / <sub>4</sub>	3.30cd	2.82	30.9b	23.3	0.65b	1.14a	17.5bc	17.8a
0:1	2.42d	2.20	17.0c	17.1	0.37c	0.68b	9.9d	8.4b
Significance <sup>y</sup>	***	NS	***	NS	***	*	***	*
R <sup>2</sup>	0.71	0.21	0.74	0.35	0.71	0.47	0.75	0.53
CV%	20.27	29.33	19.24	27.57	22.55	21.01	19.15	27.63

<sup>z</sup>Means followed by the same letter indicates non significant difference according to the LSD multiple comparison test at  $P \leq 0.05$

<sup>y</sup>Significance according to ANOVA, NS, \*, \*\*, \*\*\* non significant, and significant at  $P \leq 0.05$ ,  $P \leq 0.01$ , and  $P \leq 0.001$ , respectively

R<sup>2</sup>= Coefficient of determination

CV= Coefficient of variation

Table 6.35. Models<sup>z</sup> for the shoot and root mass, shoot:root ratio, and leaf area of bean, *Phaseolus vulgaris* L. ‘Poncho’, plants in response to K<sup>+</sup>:Na<sup>+</sup> mixtures with a 7.5 mM total concentration combined with two concentrations of HCO<sub>3</sub><sup>-</sup>. Experiment 6.6.

Coefficient <sup>y</sup>	Shoot Dry Mass (g)		Shoot Fresh Mass (g)		Root Dry Mass (g)		Root Fresh Mass (g)		Shoot:Root Ratio (g/g <sup>-1</sup> )		Leaf Area (cm <sup>2</sup> )	
	7.5 mM Total Mixture											
	HCO <sub>3</sub> <sup>-</sup> (mM)		HCO <sub>3</sub> <sup>-</sup> (mM)		HCO <sub>3</sub> <sup>-</sup> (mM)		HCO <sub>3</sub> <sup>-</sup> (mM)		HCO <sub>3</sub> <sup>-</sup> (mM)		HCO <sub>3</sub> <sup>-</sup> (mM)	
	0	7.5	0	7.5	0	7.5	0	7.5	0	7.5	0	7.5
Slack var.									+6.01	+2.77		
β <sub>1</sub>	+5.31	+2.74	+42.94	+25.11	+0.89	+0.96	+19.90	+19.90	-0.47	-0.30	+1455	+684
β <sub>2</sub>	+2.57	+2.34	+20.82	+18.46	+0.37	+0.76	+10.12	+10.12	-	-	+526	+506
β <sub>3</sub>	-	-	-	-	+0.51	+1.15	+14.68	+14.68	-	-	+987	+171
Model	Linear		Linear		Quadratic		Quadratic		Modified		Quadratic	
Lack of fit <sup>x</sup>	P=0.569		P=0.196		P=0.451		P=0.252		P=0.388		P=0.571	
Adeq. Prec.	14.31		14.31		11.18		8.91		15.49		14.15	
R <sup>2</sup>	0.67		0.67		0.63		0.45		0.83		0.81	
CV%	21.05		21.22		22.02		25.74		17.69		20.76	

<sup>z</sup>To estimate any parameter, multiply the coefficients indicated in the table by the proportion of the corresponding counter-ion in the mixture of interest

<sup>y</sup>β<sub>1</sub>: K<sup>+</sup>, β<sub>2</sub>: Na<sup>+</sup>, β<sub>3</sub>: Na<sup>+</sup>\*K<sup>+</sup>

<sup>x</sup>Lack of fit according to ANOVA

Adeq. Prec.=Adequate precision

R<sup>2</sup>= Coefficient of determination

CV= Coefficient of variation

Table 6.36. Final equation for the growth parameters of bean, *Phaseolus vulgaris* L. ‘Poncho’, plants in response to K<sup>+</sup>:Na<sup>+</sup> mixtures with a 7.5 mM total concentration combined with two concentrations of HCO<sub>3</sub><sup>-</sup>. Experiment 6.6.

Parameter	Final equation <sup>z</sup>
Shoot Dry Mass (g)	4.03K + 2.46Na - 1.29K* HCO <sub>3</sub> <sup>-</sup> - 0.12Na*HCO <sub>3</sub> <sup>-</sup>
Shoot Fresh Mass (g)	34.03K + 19.65Na - 8.91K* HCO <sub>3</sub> <sup>-</sup> - 1.18Na*HCO <sub>3</sub> <sup>-</sup>
Root Dry Mass (g)	0.92K + 0.56Na + 0.79K*Na + 0.90K* HCO <sub>3</sub> <sup>-</sup> + 0.17Na*HCO <sub>3</sub> <sup>-</sup> + 0.31K*Na*HCO <sub>3</sub> <sup>-</sup>
Root Fresh Mass (g)	19.9K + 10.12Na + 14.67K*Na
Leaf Dry Mass (g)	2.39K + 1.56Na - 0.78K* HCO <sub>3</sub> <sup>-</sup> - 0.12Na*HCO <sub>3</sub> <sup>-</sup>
Leaf Fresh Mass (g)	21.28K + 12.10Na - 5.10K* HCO <sub>3</sub> <sup>-</sup> - 0.18Na*HCO <sub>3</sub> <sup>-</sup>
Leaf Area (cm <sup>2</sup> )	1069.3K + 515.9Na + 579.0K*Na - 385.3K* HCO <sub>3</sub> <sup>-</sup> - 9.80Na*HCO <sub>3</sub> <sup>-</sup> - 408.2K*Na*HCO <sub>3</sub> <sup>-</sup>
Water consumption (ml·plant <sup>-1</sup> )	2077.2K + 1398.0Na - 629.0K*HCO <sub>3</sub> <sup>-</sup> - 42.8Na*HCO <sub>3</sub> <sup>-</sup>
Shoot:Root Ratio (g·g <sup>-1</sup> )	4.39 - 0.39K - 1.62HCO <sub>3</sub> <sup>-</sup> + 0.09K* HCO <sub>3</sub> <sup>-</sup>
Solution pH	7.38K + 7.33Na + 0.58K* HCO <sub>3</sub> <sup>-</sup> + 0.59Na* HCO <sub>3</sub> <sup>-</sup>
Total Chlorophyll (µg·cm <sup>-2</sup> )	9.46K + 10.67Na - 1.47K*HCO <sub>3</sub> <sup>-</sup> - 1.14Na*HCO <sub>3</sub> <sup>-</sup>

<sup>z</sup>To estimate the response, the counter-ions must be expressed in terms of their proportion in the mixture of interest and HCO<sub>3</sub><sup>-</sup> takes a -1 or +1 value at a concentration of 0 and 7.5 mM, respectively

Table 6.37. Predicted response and 95% confidence interval for shoot mass, root mass, and leaf area of bean, *Phaseolus vulgaris* L. 'Poncho', plants grown in mixtures of varying proportions of K<sup>+</sup> and Na<sup>+</sup> counter-cations of HCO<sub>3</sub><sup>-</sup> with a 7.5 mM total concentration and two concentrations of HCO<sub>3</sub><sup>-</sup>. Experiment 6.6.

Mixtures K <sup>+</sup> :Na <sup>+</sup>	Shoot Dry Mass (g)			Root Dry Mass (g)			Leaf Area (cm <sup>2</sup> )		
	CI <sub>L</sub> <sup>z</sup>	CI <sub>H</sub> <sup>y</sup>	CI <sub>L</sub>	CI <sub>H</sub>	CI <sub>L</sub>	CI <sub>H</sub>			
	0 mM HCO <sub>3</sub> <sup>-</sup>								
1:0	4.96	5.53	6.11	0.73	0.89	1.06	1297	1455	1611
<sup>3</sup> / <sub>4</sub> : <sup>1</sup> / <sub>4</sub>	4.28	4.64	5.02	0.75	0.86	0.97	1301	1410	1519
<sup>1</sup> / <sub>2</sub> : <sup>1</sup> / <sub>2</sub>	3.65	3.94	4.24	0.64	0.76	0.88	1120	1237	1354
<sup>1</sup> / <sub>4</sub> : <sup>3</sup> / <sub>4</sub>	2.88	3.24	3.60	0.49	0.60	0.70	833	933	1034
0:1	2.07	2.57	3.08	0.20	0.37	0.55	355	526	696
	7.5 mM HCO <sub>3</sub> <sup>-</sup>								
1:0	2.21	2.74	3.27	0.78	0.96	1.13	513	684	855
<sup>3</sup> / <sub>4</sub> : <sup>1</sup> / <sub>4</sub>	2.26	2.64	3.02	1.01	1.12	1.23	562	662	782
<sup>1</sup> / <sub>2</sub> : <sup>1</sup> / <sub>2</sub>	2.24	2.54	2.84	1.02	1.15	1.28	511	638	764
<sup>1</sup> / <sub>4</sub> : <sup>3</sup> / <sub>4</sub>	2.08	2.44	2.80	0.91	1.02	1.13	473	581	689
0:1	1.84	2.34	2.84	0.61	0.76	0.92	351	506	661

<sup>z</sup>CI<sub>L</sub>=low confidence interval

<sup>y</sup>CI<sub>H</sub>=high confidence interval

7.5 mM  $\text{HCO}_3^-$ . There was not a significant decrease on shoot mass with increasing proportions of  $\text{Na}^+$  (Table 6.35)(Fig. 6.24C). The decrease in the  $\text{Na}^+$  pure blend (coefficient  $\beta_2$  in Table 6.35) was 15% compared to the  $\text{K}^+$  pure blend (coefficient  $\beta_1$ ).

*General Effect of  $\text{HCO}_3^-$ .* The separation of lines in Fig. 6.24C indicated that the detrimental effect of  $\text{HCO}_3^-$  was greater than the effect at the 2.5 and 5 mM total mixtures (Fig. 6.24A and B).

The non parallel curves in Fig. 6.24C indicated that the inhibition of shoot growth was not proportionally similar in both vertices,  $\text{K}^+$  and  $\text{Na}^+$ . In the  $\text{K}^+$  vertex, shoot dry mass decreased 48% by the addition of  $\text{HCO}_3^-$  (compare  $\beta_1$  coefficients in Table 6.35), but in the  $\text{Na}^+$  vertex, the decrease was 9%. This suggested that at 7.5 mM  $\text{Na}^+$  plus 7.5 mM  $\text{HCO}_3^-$ ,  $\text{Na}^+$  was more detrimental for shoot mass than  $\text{HCO}_3^-$ .

#### *Root mass*

##### 2.5 and 5 mM total mixture

Total mixtures of 2.5 and 5 mM  $\text{K}^+$  and  $\text{Na}^+$  significantly affected ( $P \leq 0.05$ ) root dry mass in plants treated without  $\text{HCO}_3^-$  (Table 6.26) and with or without  $\text{HCO}_3^-$  at 5 mM (Table 6.30). The best fit in all total mixtures was a quadratic model, except for the fresh mass in the 2.5 mM total mixture (Table 6.27 and 6.31). The final equations are presented in Table 6.28 and 6.32.

There was no effect of  $\text{HCO}_3^-$  on root growth with any of the 2.5 and 5 mM total mixtures, but there was a decrease in root dry mass with increasing proportions of  $\text{Na}^+$  (Fig 6.24A and B). The decrease in root mass was significant when the proportion of  $\text{Na}^+$  was around  $3/4$  in both 2.5 and 5 mM, total mixtures, as deduced by comparing the confidence intervals (Table 6.29 and 6.33).

##### 7.5 mM total mixture

In the 7.5 mM total mixture, the proportion of  $\text{K}^+$  and  $\text{Na}^+$  significantly affected ( $P \leq 0.05$ ) root dry and fresh mass in plants treated with both  $\text{HCO}_3^-$  and no  $\text{HCO}_3^-$  (Table 6.34). The best fit was a quadratic model for both root parameters (Table 6.35).

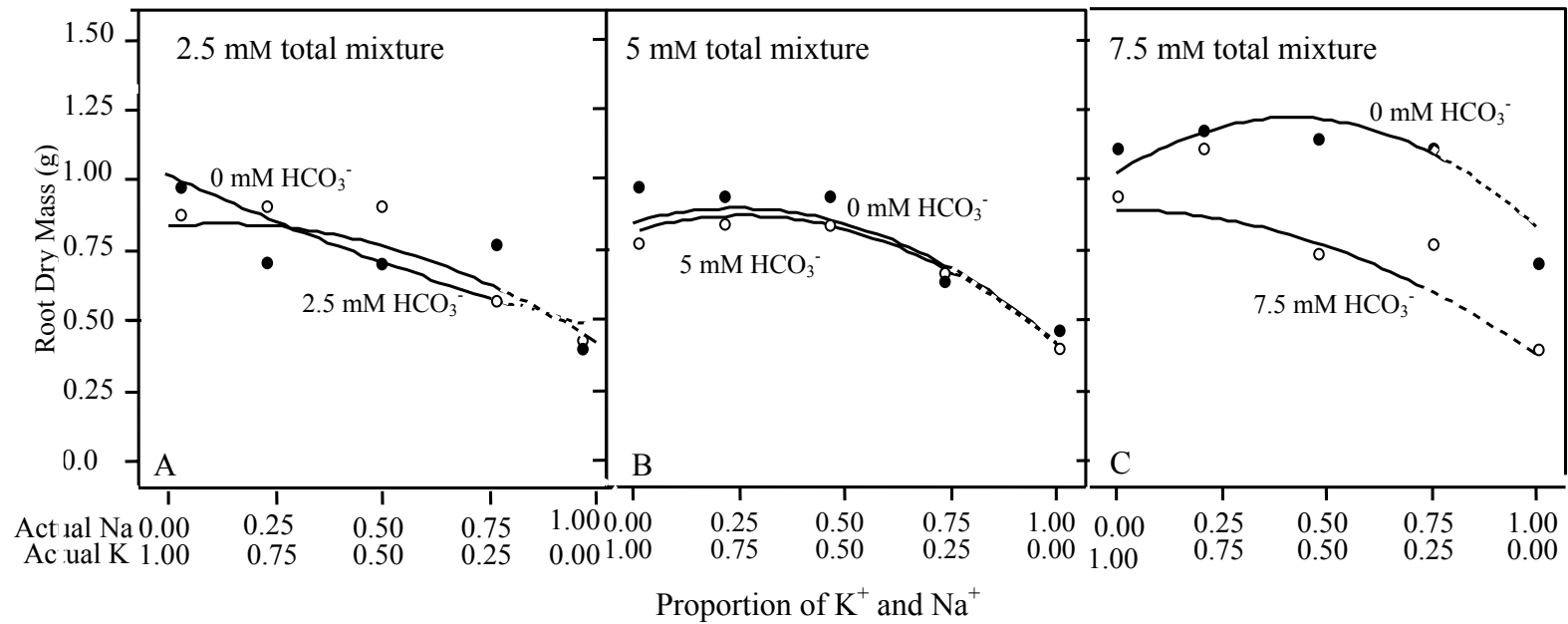

Fig. 6.25. Effect of 2.5, 5, and 7.5 mM total mixtures of varying K<sup>+</sup> and Na<sup>+</sup> proportions at two levels of HCO<sub>3</sub><sup>-</sup> on root dry mass of bean, *Phaseolus vulgaris* L. 'Poncho', plants. Open symbols=0 mM HCO<sub>3</sub><sup>-</sup>. Closed symbols=2.5, 5, or 7.5 mM HCO<sub>3</sub><sup>-</sup>. Dashed portion indicates a region of a probable K<sup>+</sup> deficiency effect.

When  $\text{HCO}_3^-$  was added to the  $\text{K}^+:\text{Na}^+$  mixtures, there was an increase in root mass (Fig. 6.22C). The promoting effect of  $\text{HCO}_3^-$  was greatest when  $\text{K}^+$  and  $\text{Na}^+$  were blended at equal proportions or in the  $3/4:1/4$  mixture (Fig. 6.25C).

According to the models, root dry mass of plants treated with no  $\text{HCO}_3^-$  decreased with increasing proportions of  $\text{Na}^+$  (Table 6.35)(Fig. 6.25C). Based on the confidence intervals, without  $\text{HCO}_3^-$ , the maximum root dry mass was obtained with the 1:0  $\text{K}^+:\text{Na}^+$  blend (Table 6.37), and the maximum root mass was obtained with the blend  $3/4:1/4$  and  $1/2:1/2$  when 7.5 mM  $\text{HCO}_3^-$  was added to the mixtures (Table 6.37).

#### *Shoot:root ratio*

Total mixtures of 2.5 mM (Table 6.38) did not significantly affect ( $P>0.05$ ) shoot:root ratio, with or without  $\text{HCO}_3^-$ . In the 5 mM total mixture, the proportion of  $\text{K}^+$  and  $\text{Na}^+$  significantly affected ( $P\leq 0.05$ ) shoot:root ratio in mixtures containing no  $\text{HCO}_3^-$  (Table 6.39). In the 7.5 mM total mixture, there were not significant differences (Table 6.40).

The models for all three total mixtures indicated that there was only a significant  $\text{K}^+$  effect (Table 6.27, 6.31, and 6.35). The general response to  $\text{HCO}_3^-$  was a decrease in shoot:root ratio as  $\text{K}^+$  proportion increased (Table 6.27, 6.31, and 6.35).

#### *Leaf growth*

Based on ANOVA, in all three total mixtures, leaf growth parameters (leaf area, and leaf dry and fresh mass), were significantly affected by the proportion of  $\text{K}^+$  and  $\text{Na}^+$  in mixtures containing no  $\text{HCO}_3^-$  (Table 6.38, 6.39 and 6.40). With  $\text{HCO}_3^-$ , leaf growth parameters were unaffected in the 2.5 mM total mixture (Table 6.38). In the 5 and 7.5 mM total mixtures, there were not significant differences in leaf area and leaf mass ( $P\leq 0.05$ )(Table 6.39 and 6.40).

The typical response was represented by leaf dry mass (Fig. 6.26). The response was very similar to that of shoot mass (Fig. 6.24) The models, effect of  $\text{HCO}_3^-$ , and individual effects of  $\text{K}^+$  and  $\text{Na}^+$  on leaf growth, showed a similar trend if compared to shoot mass (Table 6.41, 6.42, and 6.43).

Table 6.38. Effect of mixtures of varying proportions of K<sup>+</sup> and Na<sup>+</sup> counter-cations of HCO<sub>3</sub><sup>-</sup> on shoot:root ratio and leaf growth parameters of bean, *Phaseolus vulgaris* L. ‘Poncho’, plants in a 2.5 mM total concentration and two levels of HCO<sub>3</sub><sup>-</sup>. Experiment 6.6.

Mixtures K <sup>+</sup> :Na <sup>+</sup>	Shoot:Root Ratio <sup>z</sup> (g/g <sup>-1</sup> )		Leaf Area (cm <sup>2</sup> )		Leaf Dry Mass (g)		Leaf Fresh Mass (g)	
	2.5 mM Total Mixture							
	HCO <sub>3</sub> <sup>-</sup> (mM)		HCO <sub>3</sub> <sup>-</sup> (mM)		HCO <sub>3</sub> <sup>-</sup> (mM)		HCO <sub>3</sub> <sup>-</sup> (mM)	
	0	2.5	0	2.5	0	2.5	0	2.5
1:0	5.59	3.85	1319a	916a	2.69a	1.85ab	23.4a	17.0
<sup>3</sup> / <sub>4</sub> : <sup>1</sup> / <sub>4</sub>	5.94	4.90	1304a	902a	2.97a	2.07ab	26.8a	17.8
<sup>1</sup> / <sub>2</sub> : <sup>1</sup> / <sub>2</sub>	5.77	5.21	1306a	921a	2.89a	2.11a	22.8a	17.6
<sup>1</sup> / <sub>4</sub> : <sup>3</sup> / <sub>4</sub>	5.90	4.22	1010b	809ab	2.19b	1.81ab	16.9b	15.7
0:1	5.79	5.01	519c	540b	1.50c	1.34b	9.6c	11.8
Significance <sup>y</sup>	NS	NS	***	*	***	NS	***	NS
R <sup>2</sup>	0.04	0.18	0.78	0.442	0.82	0.29	0.78	0.37
CV%	12.02	27.34	17.22	22.98	12.09	27.28	18.86	20.86

<sup>z</sup>Means followed by the same letter indicates non significant difference according to the LSD multiple comparison test at  $P \leq 0.05$

<sup>y</sup>Significance according to ANOVA, NS, \*, \*\*, \*\*\* non significant, and significant at  $P \leq 0.05$ ,  $P \leq 0.01$ , and  $P \leq 0.001$ , respectively

R<sup>2</sup>= Coefficient of determination

CV= Coefficient of variation



Table 6.39. Effect of mixtures of varying proportions of K<sup>+</sup> and Na<sup>+</sup> counter-cations of HCO<sub>3</sub><sup>-</sup> on shoot:root ratio and leaf growth parameters of bean, *Phaseolus vulgaris* L. ‘Poncho’, plants in a 5 mM total concentration and two levels of HCO<sub>3</sub><sup>-</sup>. Experiment 6.6.

Mixtures K <sup>+</sup> :Na <sup>+</sup>	Shoot:Root Ratio <sup>z</sup> (g/g <sup>-1</sup> )		Leaf Area (cm <sup>2</sup> )		Leaf Dry Mass (g)		Leaf Fresh Mass (g)	
	5 mM Total Mixture							
	HCO <sub>3</sub> <sup>-</sup> (mM)		HCO <sub>3</sub> <sup>-</sup> (mM)		HCO <sub>3</sub> <sup>-</sup> (mM)		HCO <sub>3</sub> <sup>-</sup> (mM)	
	0	5	0	5	0	5	0	5
1:0	5.89abc	2.86b	1329a	676	2.69a	1.62	22.6a	15.6
<sup>3</sup> / <sub>4</sub> : <sup>1</sup> / <sub>4</sub>	5.37c	3.38b	1364a	870	2.69a	1.73	23.1a	17.8
<sup>1</sup> / <sub>2</sub> : <sup>1</sup> / <sub>2</sub>	5.65bc	3.31b	975a	766	2.81a	1.78	23.5a	16.7
<sup>1</sup> / <sub>4</sub> : <sup>3</sup> / <sub>4</sub>	6.47a	3.52b	1249a	527	2.58a	1.31	21.5a	11.3
0:1	6.03ab	5.04a	459b	549	1.29b	1.32	8.0b	13.3
Significance <sup>y</sup>	*	*	**	NS	***	NS	***	NS
R <sup>2</sup>	0.50	0.47	0.59	0.24	0.70	0.21	0.75	0.22
CV%	7.28	25.15	30.33	39.18	17.64	29.46	19.90	34.06

<sup>z</sup>Means followed by the same letter indicates non significant difference according to the LSD multiple comparison test at  $P \leq 0.05$

<sup>y</sup>Significance according to ANOVA, NS, \*, \*\*, \*\*\* non significant, and significant at  $P \leq 0.05$ ,  $P \leq 0.01$ , and  $P \leq 0.001$ , respectively

R<sup>2</sup>= Coefficient of determination

CV= Coefficient of variation

Table 6.40. Effect of mixtures of varying proportions of K<sup>+</sup> and Na<sup>+</sup> counter-cations of HCO<sub>3</sub><sup>-</sup> on shoot:root ratio and leaf growth parameters of bean, *Phaseolus vulgaris* L. ‘Poncho’, plants in a 7.5 mM total concentration and two levels of HCO<sub>3</sub><sup>-</sup>. Experiment 6.6.

Mixtures K <sup>+</sup> :Na <sup>+</sup>	Shoot:Root Ratio <sup>z</sup> (g/g <sup>-1</sup> )		Leaf Area (cm <sup>2</sup> )		Leaf Dry Mass (g)		Leaf Fresh Mass (g)	
	7.5 mM Total Mixture							
	HCO <sub>3</sub> <sup>-</sup> (mM)		HCO <sub>3</sub> <sup>-</sup> (mM)		HCO <sub>3</sub> <sup>-</sup> (mM)		HCO <sub>3</sub> <sup>-</sup> (mM)	
	0	5	0	7.5	0	7.5	0	7.5
1:0	5.84	2.88	1406ab	874	2.93ab	1.90	23.8ab	18.3a
<sup>3</sup> / <sub>4</sub> : <sup>1</sup> / <sub>4</sub>	5.35	2.42	1605a	714	3.29a	1.70	27.1a	16.8ab
<sup>1</sup> / <sub>2</sub> : <sup>1</sup> / <sub>2</sub>	5.72	2.23	1164bc	539	2.31bc	1.36	20.1b	12.7bc
<sup>1</sup> / <sub>4</sub> : <sup>3</sup> / <sub>4</sub>	5.22	2.54	1084c	672	2.18cd	1.71	18.5b	15.0abc
0:1	6.50	3.27	504d	503	1.52d	1.35	9.6c	11.0c
Significance <sup>y</sup>	NS	NS	***	NS	***	NS	***	NS
R <sup>2</sup>	0.38	0.26	0.84	0.34	0.69	0.26	0.74	0.41
CV%	11.60	26.67	16.08	32.21	19.46	26.42	20.22	25.03

<sup>z</sup>Means followed by the same letter indicates non significant difference according to the LSD multiple comparison test at  $P \leq 0.05$

<sup>y</sup>Significance according to ANOVA, NS, \*, \*\*, \*\*\* non significant, and significant at  $P \leq 0.05$ ,  $P \leq 0.01$ , and  $P \leq 0.001$ , respectively

R<sup>2</sup>= Coefficient of determination

CV= Coefficient of variation

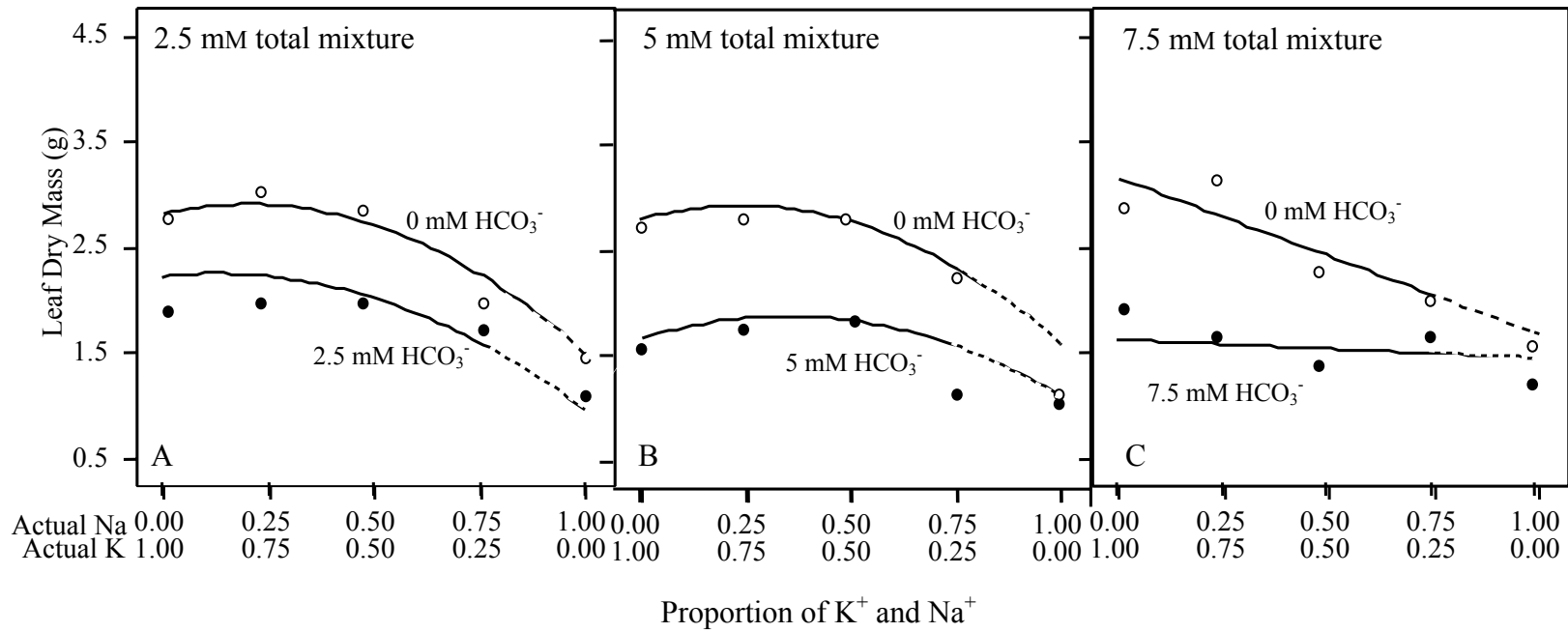

Fig. 6.26. Effect of 2.5, 5, and 7.5 mM total mixtures of varying K<sup>+</sup> and Na<sup>+</sup> proportions at two levels of HCO<sub>3</sub><sup>-</sup> on leaf dry mass of bean, *Phaseolus vulgaris* L. 'Poncho', plants. Open symbols=0 mM HCO<sub>3</sub><sup>-</sup>. Closed symbols=2.5, 5, or 7.5 mM HCO<sub>3</sub><sup>-</sup>. Dashed portion indicates a region of a probable K<sup>+</sup> deficiency effect.

Table 6.41. Models<sup>z</sup> for leaf mass, solution pH, total chlorophyll concentration, and water consumption of bean, *Phaseolus vulgaris* L. ‘Poncho’, plants in response to K<sup>+</sup>:Na<sup>+</sup> mixtures with a 2.5 mM total concentration combined with two concentrations of HCO<sub>3</sub><sup>-</sup>. Experiment 6.6.

Coefficient <sup>y</sup>	Leaf Dry Mass (g)		Leaf Fresh Mass (g)		Solution pH		Total Chlorophyll (µg·cm <sup>-2</sup> )		Water Consumption (ml·plant <sup>-1</sup> )	
	2.5 mM Total Mixture									
	HCO <sub>3</sub> <sup>-</sup> (mM)		HCO <sub>3</sub> <sup>-</sup> (mM)		HCO <sub>3</sub> <sup>-</sup> (mM)		HCO <sub>3</sub> <sup>-</sup> (mM)		HCO <sub>3</sub> <sup>-</sup> (mM)	
	0	2.5	0	2.5	0	2.5	0	2.5	0	2.5
β <sub>1</sub>	+2.82	+2.35	+24.96	+20.49	5.84	7.60	+10.17	+9.85	+2502	+2051
β <sub>2</sub>	+1.50	+1.10	+9.50	+11.05	6.82	7.57	+12.92	+9.65	+1709	+1099
β <sub>3</sub>	+2.21	+1.69	+20.32	+9.16	-	-	-	-	-	-
Model	Quadratic		Quadratic		Linear		Linear		Linear	
Lack of fit <sup>x</sup>	P=0.849		P=0.993		P=0.052		P=0.609		P=0.719	
Adeq. Prec.	10.63		9.90		8.48		8.41		10.15	
R <sup>2</sup>	0.65		0.65		0.55		0.48		0.49	
CV%	19.54		21.43		9.57		11.51		23.15	

<sup>z</sup>To estimate any parameter, multiply the coefficients indicated in the table by the proportion of the corresponding counter-ion in the mixture of interest

<sup>y</sup>β<sub>1</sub>: K<sup>+</sup>, β<sub>2</sub>: Na<sup>+</sup>, β<sub>3</sub>: Na<sup>+</sup>\*K<sup>+</sup>

<sup>x</sup>Lack of fit according to ANOVA

Adeq. Prec.=Adequate precision

R<sup>2</sup>= Coefficient of determination

CV= Coefficient of variation

Table 6.42. Models<sup>z</sup> for leaf mass, solution pH, total chlorophyll concentration, and water consumption of bean, *Phaseolus vulgaris* L. ‘Poncho’, plants in response to K<sup>+</sup>:Na<sup>+</sup> mixtures with a 5 mM total concentration combined with two concentrations of HCO<sub>3</sub><sup>-</sup>. Experiment 6.6.

Coefficient <sup>x</sup>	Leaf Dry Mass (g)		Leaf Fresh Mass (g)		Solution pH		Total Chlorophyll (µg·cm <sup>-2</sup> )		Water Consumption <sup>y</sup> (ml·plant <sup>-1</sup> )	
	5 mM Total Mixture									
	HCO <sub>3</sub> <sup>-</sup> (mM)		HCO <sub>3</sub> <sup>-</sup> (mM)		HCO <sub>3</sub> <sup>-</sup> (mM)		HCO <sub>3</sub> <sup>-</sup> (mM)		HCO <sub>3</sub> <sup>-</sup> (mM)	
	0	5	0	5	0	5	0	5	0	5
Slack var.									+1963	+1234
β <sub>1</sub>	+2.79	+1.69	+23.65	+16.25	+6.58	+7.97	+10.57	+9.55	+668	+495
β <sub>2</sub>	+1.61	+1.13	+10.32	+10.67	+6.74	+7.78	+11.26	+8.66	-	-
β <sub>3</sub>	+2.29	+1.79	+26.43	+16.72	-	-	-	-	-	-
Model	Quadratic		Quadratic		Linear		Linear		Modified	
Lack of fit <sup>w</sup>	P=0.242		P=0.289		P=0.681		P=0.545		P=0.063	
Adeq. Prec.	9.01		7.54		8.82		7.34		9.52	
R <sup>2</sup>	0.56		0.48		0.58		0.40		0.49	
CV%	26.95		30.74		7.39		12.24		26.64	

<sup>z</sup>To estimate any parameter, multiply the coefficients indicated in the table by the proportion of the corresponding counter-ion in the mixture of interest

<sup>y</sup>β<sub>1</sub>: K<sup>+</sup>, β<sub>2</sub>: K<sup>+</sup>

<sup>x</sup>β<sub>1</sub>: K<sup>+</sup>, β<sub>2</sub>: Na<sup>+</sup>, β<sub>3</sub>: Na<sup>+</sup>\*K<sup>+</sup>

<sup>w</sup>Lack of fit according to ANOVA

Adeq. Prec.=Adequate precision

R<sup>2</sup>= Coefficient of determination

CV= Coefficient of variation

Table 6.43. Models<sup>z</sup> for leaf mass, solution pH, total chlorophyll concentration, and water consumption of bean, *Phaseolus vulgaris* L. ‘Poncho’, plants in response to K<sup>+</sup>:Na<sup>+</sup> mixtures with a 7.5 mM total concentration combined with two concentrations of HCO<sub>3</sub><sup>-</sup>. Experiment 6.6.

Coefficient <sup>y</sup>	Leaf Dry Mass (g)		Leaf Fresh Mass (g)		Solution pH		Total Chlorophyll (µg·cm <sup>-2</sup> )		Water Consumption (ml·plant <sup>-1</sup> )	
	7.5 mM Total Mixture									
	HCO <sub>3</sub> <sup>-</sup> (mM)		HCO <sub>3</sub> <sup>-</sup> (mM)		HCO <sub>3</sub> <sup>-</sup> (mM)		HCO <sub>3</sub> <sup>-</sup> (mM)		HCO <sub>3</sub> <sup>-</sup> (mM)	
	0	7.5	0	7.5	0	7.5	0	7.5	0	7.5
β <sub>1</sub>	+3.16	+1.61	+26.38	+16.18	+6.81	+7.96	+10.93	+7.99	+2706	+1448
β <sub>2</sub>	+1.68	+1.44	+12.28	+11.92	+6.74	+7.91	+11.81	+9.53	+1441	+1355
β <sub>3</sub>	-	-	-	-	-	-	-	-	-	-
Model	Linear		Linear		Linear		Linear		Linear	
Lack of fit <sup>x</sup>	P=0.593		P=0.113		P=0.025		P=0.573		P=0.383	
Adeq. Prec.	13.98		13.10		7.76		8.27		9.40	
R <sup>2</sup>	0.67		0.60		0.59		0.47		0.51	
CV%	20.47		21.77		6.92		14.99		27.14	

<sup>z</sup>To estimate any parameter, multiply the coefficients indicated in the table by the proportion of the corresponding counter-ion in the mixture of interest

<sup>y</sup>β<sub>1</sub>: K<sup>+</sup>, β<sub>2</sub>: Na<sup>+</sup>, β<sub>3</sub>: Na<sup>+</sup>\*K<sup>+</sup>

<sup>x</sup>Lack of fit according to ANOVA

Adeq. Prec.=Adequate precision

R<sup>2</sup>= Coefficient of determination

CV= Coefficient of variation

### *Total chlorophyll*

According to ANOVA, in all total mixtures, total chlorophyll concentration was unaffected significantly by the proportion of  $K^+$  and  $Na^+$  in solutions containing either no  $HCO_3^-$  or  $HCO_3^-$ , excluding the 2.5 mM total mixture (Table 6.44, 6.45, and 6.46). The best fit to the response in all three total mixtures was a linear model (Tables 6.41, 6.42, 6.43).

Based on the models,  $HCO_3^-$  induced a decrease in the concentration of chlorophyll in all three total mixture concentrations (Fig. 6.27A, B, and C). This conclusion was supported by the negative coefficients in the final models in both interactions  $K \cdot HCO_3^-$  and  $Na \cdot HCO_3^-$  (Table 6.28, 6.32, 6.36).

Without  $HCO_3^-$ , the concentration of chlorophyll increased as the proportion of  $Na^+$  increased in all three total mixture concentrations (Fig. 6.27). The greatest increase was in the 2.5 mM total mixture (Fig. 6.27A), in which the maximum chlorophyll concentration was predicted to occur in the 0:1 mixture. The confidence interval for the prediction did not overlap with the intervals of the mixtures 1:0 and  $3/4:1/4$  (Table 6.47).

In the 5 mM and 7.5 mM total mixtures, the confidence intervals overlapped (Table 6.48 and 6.49), indicating a non significant effect.

In solutions containing  $HCO_3^-$ , the proportion of  $K^+$  and  $Na^+$  did not significantly affect chlorophyll concentration at the 2.5 and 5 mM total mixture concentrations (Fig. 6.27 A-B). At the 7.5 mM total mixture, chlorophyll content increased with increasing proportions of  $Na^+$  (Fig. 6.27C).

### *Solution final pH*

In all three total mixtures (Table 6.44, 6.45, and 6.46), there was not a significant ( $P > 0.05$ ) effect of the  $K^+ : Na^+$  proportion, except for the 2.5 mM total mixture containing no  $HCO_3^-$  (Table 6.40) and the 7.5 mM total mixture containing  $HCO_3^-$  (Table 6.46). The best fit to the response was linear (Table 6.44, 6.45, 6.46). The models showed no effect of the counter-cation, but there was a strong increase in solution pH when  $HCO_3^-$  was added to the mixtures (Table 6.41, 6.42, and 6.43).

Table 6.44. Effect of mixtures of varying proportions of K<sup>+</sup> and Na<sup>+</sup> counter-cations of HCO<sub>3</sub><sup>-</sup> on solution pH, total chlorophyll concentration, and water consumption of bean, *Phaseolus vulgaris* L. ‘Poncho’, plants in a 2.5 mM total concentration and two levels of HCO<sub>3</sub><sup>-</sup>. Experiment 6.6.

Mixtures K <sup>+</sup> :Na <sup>+</sup>	Solution pH <sup>z</sup>		Total Chlorophyll (µg·cm <sup>-2</sup> )		Water Consumption (ml plant <sup>-1</sup> )	
	2.5 mM Total Mixture					
	HCO <sub>3</sub> <sup>-</sup> (mM)		HCO <sub>3</sub> <sup>-</sup> (mM)		HCO <sub>3</sub> <sup>-</sup> (mM)	
	0	2.5	0	2.5	0	2.5
1:0	5.89bc	7.70	10.4b	9.4	2353	1608
<sup>3</sup> / <sub>4</sub> : <sup>1</sup> / <sub>4</sub>	5.62c	7.37	11.5ab	9.7	2433	1708
<sup>1</sup> / <sub>2</sub> : <sup>1</sup> / <sub>2</sub>	6.96ab	7.72	10.7b	8.9	2145	1773
<sup>1</sup> / <sub>4</sub> : <sup>3</sup> / <sub>4</sub>	5.96abc	7.59	11.9ab	9.8	1933	1505
0:1	7.11a	7.60	13.4a	8.7	1643	1135
Significance <sup>y</sup>	*	NS	*	NS	NS	NS
R <sup>2</sup>	0.45	0.22	0.44	0.02	0.31	0.17
CV%	12.20	3.59	12.99	10.00	23.41	31.19

<sup>z</sup>Means followed by the same letter indicates non significant difference according to the LSD multiple comparison test at  $P \leq 0.05$

<sup>y</sup>Significance according to ANOVA, NS, \*, \*\*, \*\*\* non significant, and significant at  $P \leq 0.05$ ,  $P \leq 0.01$ , and  $P \leq 0.001$ , respectively

R<sup>2</sup>= Coefficient of determination

CV= Coefficient of variation



Table 6.45. Effect of mixtures of varying proportions of K<sup>+</sup> and Na<sup>+</sup> counter-cations of HCO<sub>3</sub><sup>-</sup> on solution pH, total chlorophyll concentration, and water consumption of bean, *Phaseolus vulgaris* L. ‘Poncho’, plants in a 5 mM total concentration and two levels of HCO<sub>3</sub><sup>-</sup>. Experiment 6.6.

Mixtures K <sup>+</sup> :Na <sup>+</sup>	Solution pH <sup>z</sup>		Total Chlorophyll (μg·cm <sup>-2</sup> )		Water Consumption (ml·plant <sup>-1</sup> )	
	5 mM Total Mixture					
	HCO <sub>3</sub> <sup>-</sup> (mM)		HCO <sub>3</sub> <sup>-</sup> (mM)		HCO <sub>3</sub> <sup>-</sup> (mM)	
	0	5	0	5	0	5
1:0	6.40	7.90	11.2	9.4	2500	1448
<sup>3</sup> / <sub>4</sub> : <sup>1</sup> / <sub>4</sub>	6.56	7.96	11.0	10.1	2333	1508
<sup>1</sup> / <sub>2</sub> : <sup>1</sup> / <sub>2</sub>	6.65	7.83	10.1	8.7	2498	1725
<sup>1</sup> / <sub>4</sub> : <sup>3</sup> / <sub>4</sub>	6.31	8.04	11.3	9.4	2575	1325
0:1	6.99	7.63	11.8	7.8	1713	1195
Significance <sup>y</sup>	NS	NS	NS	NS	NS	NS
R <sup>2</sup>	0.13	0.29	0.27	0.12	0.36	0.33
CV%	11.05	3.03	9.86	15.04	21.28	30.69

<sup>z</sup>Means followed by the same letter indicates non significant difference according to the LSD multiple comparison test at  $P \leq 0.05$

<sup>y</sup>Significance according to ANOVA, NS, \*, \*\*, \*\*\* non significant, and significant at  $P \leq 0.05$ ,  $P \leq 0.01$ , and  $P \leq 0.001$ , respectively

R<sup>2</sup>= Coefficient of determination

CV= Coefficient of variation

Table 6.46. Effect of mixtures of varying proportions of K<sup>+</sup> and Na<sup>+</sup> counter-cations of HCO<sub>3</sub><sup>-</sup> on solution pH, total chlorophyll concentration, and water consumption of bean, *Phaseolus vulgaris* L. 'Poncho', plants in a 7.5 mM total concentration and two levels of HCO<sub>3</sub><sup>-</sup>. Experiment 6.6.

Mixtures K <sup>+</sup> :Na <sup>+</sup>	Solution pH <sup>z</sup>		Total Chlorophyll (μg·cm <sup>-2</sup> )		Water Consumption (ml·plant <sup>-1</sup> )	
	7.5 mM Total Mixture					
	HCO <sub>3</sub> <sup>-</sup> (mM)		HCO <sub>3</sub> <sup>-</sup> (mM)		HCO <sub>3</sub> <sup>-</sup> (mM)	
	0	7.5	0	7.5	0	7.5
1:0	6.58	8.04a	11.1	8.7	2608ab	1578
<sup>3</sup> / <sub>4</sub> : <sup>1</sup> / <sub>4</sub>	6.97	7.63a	11.4	7.0	3000a	1608
<sup>1</sup> / <sub>2</sub> : <sup>1</sup> / <sub>2</sub>	6.60	8.09ab	10.4	8.9	2153abc	1315
<sup>1</sup> / <sub>4</sub> : <sup>3</sup> / <sub>4</sub>	6.24	8.13a	11.2	9.2	1773bc	1585
0:1	7.13	7.83ab	12.0	9.7	1390c	1255
Significance <sup>y</sup>	NS	*	NS	NS	*	NS
R <sup>2</sup>	0.30	0.48	0.13	0.36	0.56	0.08
CV%	8.33	2.81	13.37	16.05	27.09	41.61

<sup>z</sup>Means followed by the same letter indicates non significant difference according to the LSD multiple comparison test at P≤0.05

<sup>y</sup>Significance according to ANOVA, NS, \*, \*\*, \*\*\* non significant, and significant at P≤0.05, P≤0.01, and P≤0.001, respectively

R<sup>2</sup>= Coefficient of determination

CV= Coefficient of variation

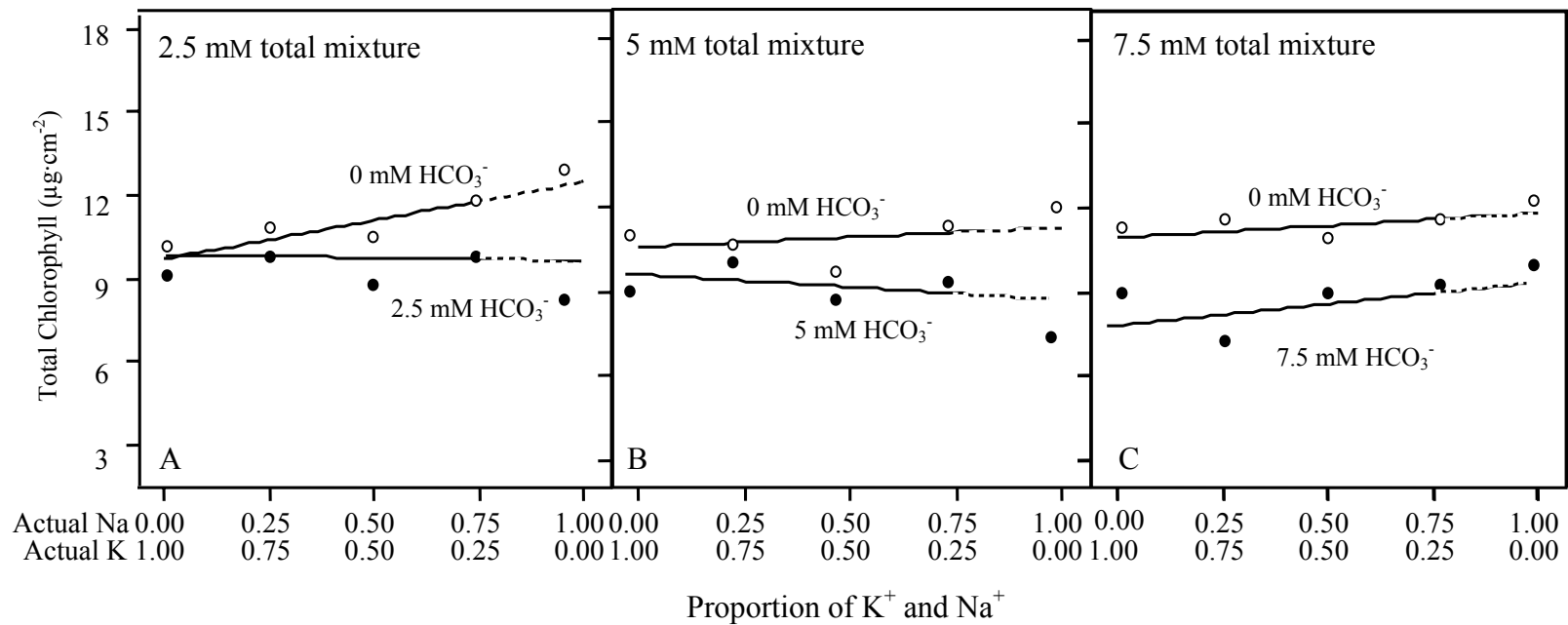

Fig. 6.27. Effect of 2.5, 5, and 7.5 mM total mixtures of varying K<sup>+</sup> and Na<sup>+</sup> proportions at two levels of HCO<sub>3</sub><sup>-</sup> on total chlorophyll concentration of bean, *Phaseolus vulgaris* L. 'Poncho', plants. Open symbols=0 mM HCO<sub>3</sub><sup>-</sup>. Closed symbols=2.5, 5, or 7.5 mM HCO<sub>3</sub><sup>-</sup>. Dashed portion indicates a region of a probable K<sup>+</sup> deficiency effect.

Table 6.47. Predicted response and 95% confidence interval for leaf mass, total chlorophyll concentration, and water consumption of bean, *Phaseolus vulgaris* L. 'Poncho', plants grown in mixtures of varying proportions of K<sup>+</sup> and Na<sup>+</sup> counter-cations of HCO<sub>3</sub><sup>-</sup> with a 2.5 mM total concentration and two concentrations of HCO<sub>3</sub><sup>-</sup>. Experiment 6.6.

Mixtures K <sup>+</sup> :Na <sup>+</sup>	Leaf Dry Mass (g)			Total Chlorophyll (μg·cm <sup>-2</sup> )		Water Consumption (ml·plant <sup>1</sup> )			
	CI <sub>L</sub> <sup>z</sup>		CI <sub>H</sub> <sup>y</sup>	CI <sub>L</sub>	CI <sub>H</sub>	CI <sub>L</sub>	CI <sub>H</sub>		
	0 mM HCO <sub>3</sub> <sup>-</sup>								
1:0	2.45	2.83	3.20	9.30	10.17	11.05	2191	2502	2813
<sup>3</sup> / <sub>4</sub> : <sup>1</sup> / <sub>4</sub>	2.65	2.91	3.16	10.22	10.84	11.47	2086	2309	2532
<sup>1</sup> / <sub>2</sub> : <sup>1</sup> / <sub>2</sub>	2.41	2.71	3.01	11.01	11.55	12.08	1916	2106	2295
<sup>1</sup> / <sub>4</sub> : <sup>3</sup> / <sub>4</sub>	1.99	2.26	2.53	11.54	12.21	12.89	1673	1913	2152
0:1	1.08	1.50	1.92	11.96	12.92	13.88	1368	1709	2050
	2.5 mM HCO <sub>3</sub> <sup>-</sup>								
1:0	1.93	2.35	2.78	8.84	9.85	10.86	1692	2050	2409
<sup>3</sup> / <sub>4</sub> : <sup>1</sup> / <sub>4</sub>	2.07	2.36	2.65	9.09	9.80	10.52	1565	1819	2074
<sup>1</sup> / <sub>2</sub> : <sup>1</sup> / <sub>2</sub>	1.83	2.15	2.47	9.16	9.75	10.34	1366	1575	1784
<sup>1</sup> / <sub>4</sub> : <sup>3</sup> / <sub>4</sub>	1.46	1.75	2.03	8.97	9.70	10.43	1084	1343	1603
0:1	0.62	1.10	1.58	8.60	9.65	10.70	727	1099	1472

<sup>z</sup>CI<sub>L</sub>=low confidence interval

<sup>y</sup>CI<sub>H</sub>=high confidence interval

Table 6.48. Predicted response and 95% confidence interval for leaf mass, total chlorophyll concentration, and water consumption of bean, *Phaseolus vulgaris* L. ‘Poncho’, plants grown in mixtures of varying proportions of K<sup>+</sup> and Na<sup>+</sup> counter-cations of HCO<sub>3</sub><sup>-</sup> with a 5 mM total concentration and two concentrations of HCO<sub>3</sub><sup>-</sup>. Experiment 6.6.

Mixtures K <sup>+</sup> :Na <sup>+</sup>	Leaf Dry Mass (g)			Total Chlorophyll (μg·cm <sup>-2</sup> )		Water Consumption (ml·plant <sup>1</sup> )			
	CI <sub>L</sub> <sup>z</sup>		CI <sub>H</sub> <sup>y</sup>	CI <sub>L</sub>	CI <sub>H</sub>	CI <sub>L</sub>		CI <sub>H</sub>	
	0 mM HCO <sub>3</sub> <sup>-</sup>								
1:0	2.32	2.80	3.27	9.71	10.57	11.43	2277	2631	2985
<sup>3</sup> / <sub>4</sub> : <sup>1</sup> / <sub>4</sub>	2.62	2.93	3.24	10.13	10.74	11.35	2217	2469	2720
<sup>1</sup> / <sub>2</sub> : <sup>1</sup> / <sub>2</sub>	2.41	2.78	3.14	10.40	10.92	11.44	2084	2297	2509
<sup>1</sup> / <sub>4</sub> : <sup>3</sup> / <sub>4</sub>	2.03	2.35	2.68	10.43	11.09	11.74	1864	2134	2404
0:1	1.09	1.61	2.14	10.33	11.27	12.21	1576	1963	2349
	5 mM HCO <sub>3</sub> <sup>-</sup>								
1:0	1.21	1.69	2.16	8.68	9.55	10.43	1368	1730	2091
<sup>3</sup> / <sub>4</sub> : <sup>1</sup> / <sub>4</sub>	1.56	1.88	2.20	8.71	9.34	9.96	1350	1609	1868
<sup>1</sup> / <sub>2</sub> : <sup>1</sup> / <sub>2</sub>	1.50	1.88	2.22	8.60	9.10	9.61	1275	1481	1689
<sup>1</sup> / <sub>4</sub> : <sup>3</sup> / <sub>4</sub>	1.31	1.62	1.93	8.29	8.89	9.49	1114	1361	1609
0:1	0.66	1.13	1.61	7.80	8.66	9.51	882	1234	1586

<sup>z</sup>CI<sub>L</sub>=low confidence interval

<sup>y</sup>CI<sub>H</sub>=high confidence interval



### *Water consumption*

Water consumption was significantly ( $P \leq 0.05$ ) affected by the  $K^+ : Na^+$  proportion in solutions containing no  $HCO_3^-$  in the 5 and 7.5 mM total mixtures (Table 6.45 and 6.46). The difference was not significant ( $P > 0.05$ ) in mixtures with  $HCO_3^-$  (Table 6.45 and 6.46). In the 2.5 mM total mixture, there were significant differences ( $P \leq 0.05$ ) in plants grown in  $HCO_3^-$  and no significant ( $P > 0.05$ ) in plants grown with no  $HCO_3^-$  (Table 6.44). The best fit to the response was a linear model (Table 6.41, 6.42, and 6.43).

Water uptake was associated to the shoot mass accumulation. In general, increased shoot dry mass accumulation was associated to increasing water consumption (Fig. 6.28 and 6.24). Bicarbonate and increasing  $Na^+$  proportions decreased water uptake.

### *$K^+$ and $Na^+$ net uptake*

The net uptake of  $K^+$  increased by 20% in the  $K^+$  pure blend when 7.5 mM  $HCO_3^-$  was added to the solution (Fig. 6.29A). In the  $1/2 : 1/2$   $K^+ : Na^+$  mixture the uptake increased by 31% (Fig. 6.29A). Similar trend is observed in the net uptake of  $Na^+$  (Fig. 6.29B). Bicarbonate was associated to a 100% and 49% increase in  $Na^+$  uptake in the  $1/2 : 1/2$  and 0:1 mixtures, respectively.

## **Discussion**

### *Shoot growth*

#### 2.5 mM total mixture

*Counter-Cation Effect.* In the 2.5 mM total mixture, shoot dry mass responded to the proportion of counter-cations according to the ranking (high to low growth; low to high toxicity):

$$K^+ > Na^+$$

in mixtures with or without  $HCO_3^-$  (Fig. 6.24A). This indicated that  $Na^+$  had a negative effect of plant growth.

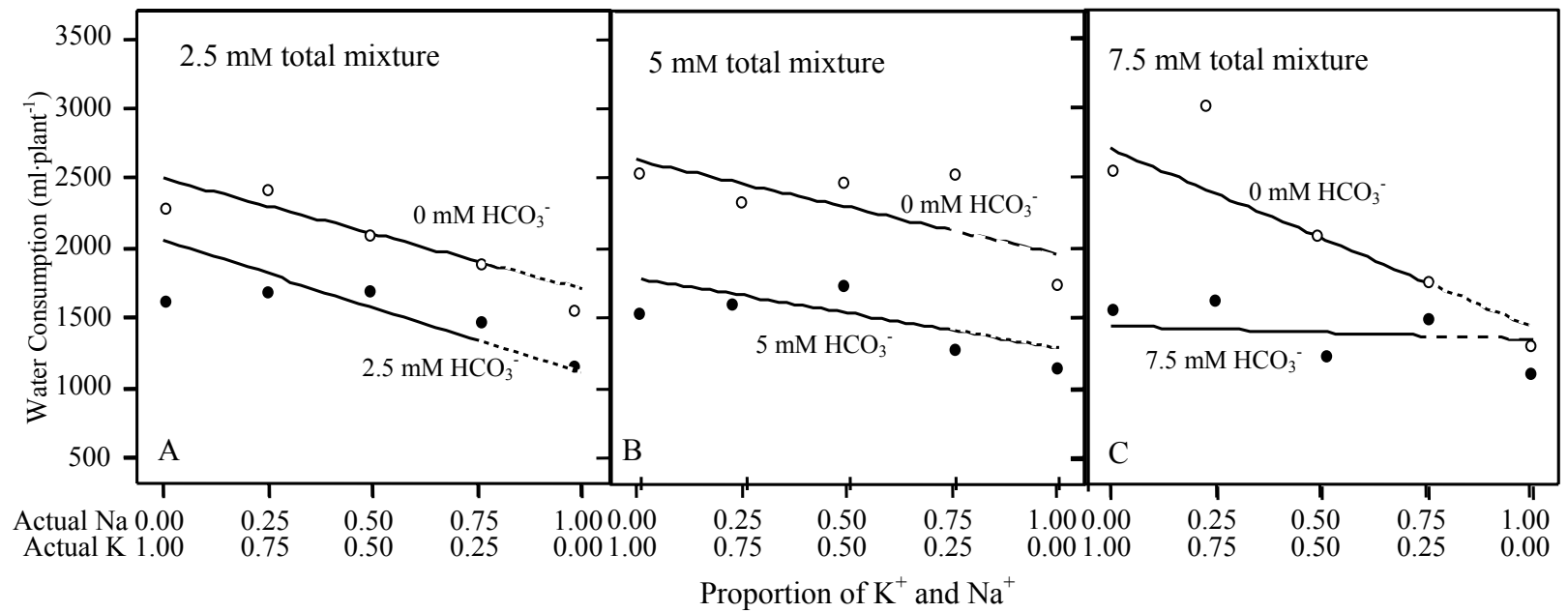

Fig. 6.28. Effect of 2.5, 5, and 7.5 mM total mixtures of varying K<sup>+</sup> and Na<sup>+</sup> proportions at two levels of HCO<sub>3</sub><sup>-</sup> on water consumption of bean, *Phaseolus vulgaris* L. 'Poncho', plants. Open symbols=0 mM HCO<sub>3</sub><sup>-</sup>. Closed symbols=2.5, 5, or 7.5 mM HCO<sub>3</sub><sup>-</sup>. Dashed portion indicates a region of a probable K<sup>+</sup> deficiency effect.



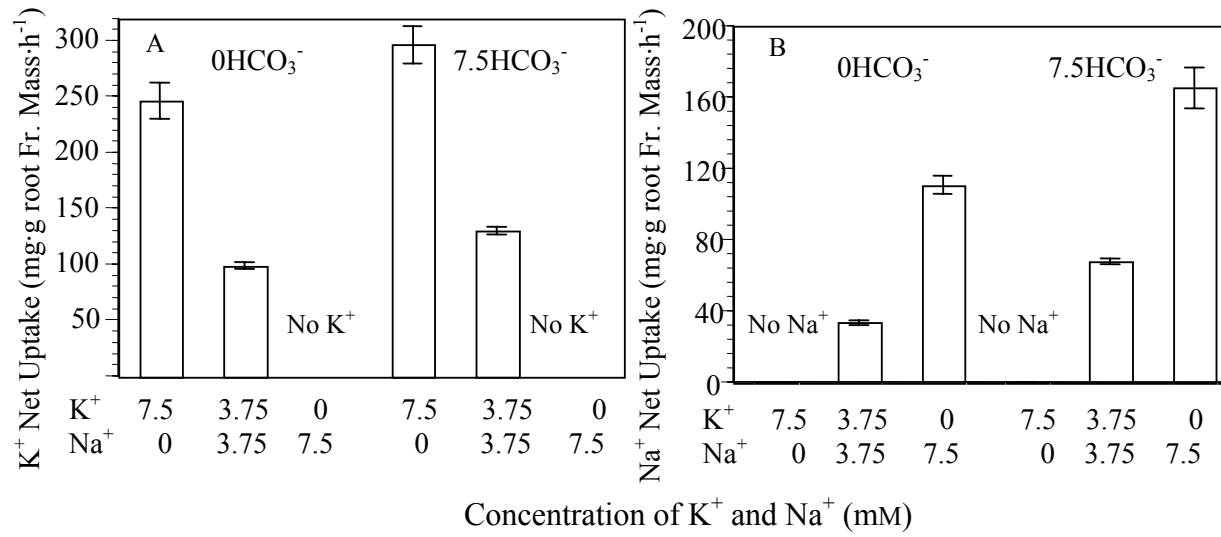

Fig. 6.29. Effect of mixtures of a 7.5 mM mixture of varying proportions of K<sup>+</sup> and Na<sup>+</sup> at two levels of HCO<sub>3</sub><sup>-</sup> on K<sup>+</sup> (A) and Na<sup>+</sup> (B) net uptake of bean, *Phaseolus vulgaris* L. 'Poncho', plants. Bars represent the standard error for the mean (n=4).

*HCO<sub>3</sub><sup>-</sup> Effect.* Plants grown in the <sup>1</sup>/<sub>4</sub>:<sup>3</sup>/<sub>4</sub> and 0:1 mixtures showed significantly lower dry mass if HCO<sub>3</sub><sup>-</sup> was applied (Table 6.27), suggesting that the detrimental effect of HCO<sub>3</sub><sup>-</sup> was higher when it was blended with Na<sup>+</sup>. Thus, both Na<sup>+</sup> and HCO<sub>3</sub><sup>-</sup> inhibited plant growth.

The K<sup>+</sup> pure blend, 1:0, containing no HCO<sub>3</sub><sup>-</sup>, was used as the reference point. Compared to the reference point, HCO<sub>3</sub><sup>-</sup> decreased shoot dry mass by 15%, Na<sup>+</sup> decreased shoot mass 47%, and the blend of Na<sup>+</sup> and HCO<sub>3</sub><sup>-</sup> by 62% (Table 6.27 and 6.50, Fig. 6.24A).

*Separate Na<sup>+</sup> and HCO<sub>3</sub><sup>-</sup> Effect.* As indicated in the discussion of Experiment 6.3, it is possible that at the Na<sup>+</sup> pure blend plants are under K<sup>+</sup> deficiency, hence the effects of Na<sup>+</sup> are confounded with the effects induced by a deficiency of K<sup>+</sup>, as indicated in Table 6.50 and Fig. 6.30A. To eliminate the K<sup>+</sup> deficiency effect, the mixture <sup>1</sup>/<sub>4</sub>:<sup>3</sup>/<sub>4</sub> K<sup>+</sup>:Na<sup>+</sup> was selected to delineate the separate effect of Na<sup>+</sup> from the effect of HCO<sub>3</sub><sup>-</sup> (Fig. 6.28A). As deduced from Table 6.50 and Fig. 6.31A, the combined effect of Na<sup>+</sup> plus HCO<sub>3</sub><sup>-</sup> at 2.5 mM, was a 38% reduction in shoot dry mass, with Na<sup>+</sup> and HCO<sub>3</sub><sup>-</sup> each blend was responsible for 19% decrease. These results are very similar to those reported in Experiment 6.3 (Table 6.17).

Table 6.50. Percentage decrease in shoot dry mass due to the effect of the counter-cations, HCO<sub>3</sub><sup>-</sup>, and interactions. Experiment 6.6.

Effect	Location	HCO <sub>3</sub> <sup>-</sup> (mM)	Shoot mass decrease		
			Total Mixture		
			2.5 mM	5 mM	7.5 mM
Na <sup>+</sup> toxicity/K <sup>+</sup> deficiency	Na <sup>+</sup> vertex	0	47%	44%	54%
HCO <sub>3</sub> <sup>-</sup>	Na <sup>+</sup> vertex	According to total mixture	15%	16%	4%
Na <sup>+</sup> toxicity	Na <sup>+</sup> vertex	0	19%	17%	41%
HCO <sub>3</sub> <sup>-</sup>	Na <sup>+</sup> vertex	According to total mixture	19%	24%	15%

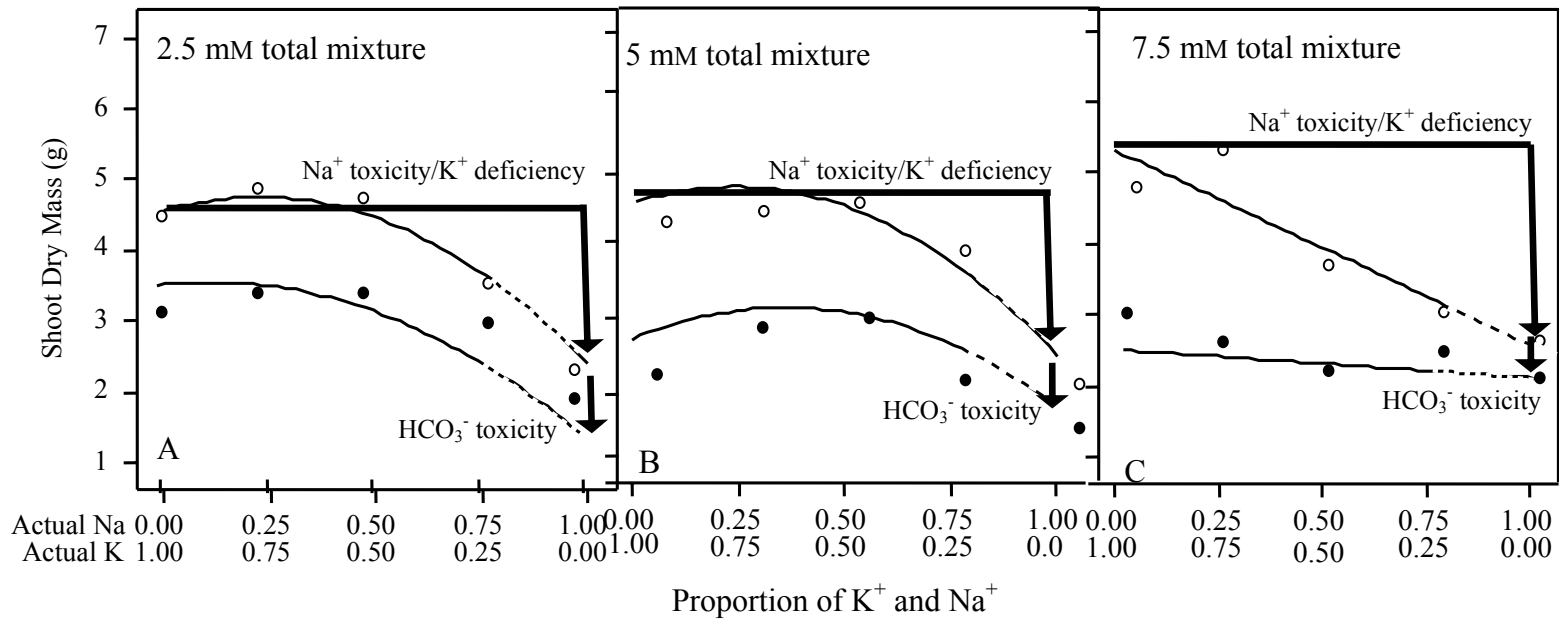

Fig. 6.30. Separation of the Na<sup>+</sup> toxicity/K<sup>+</sup> deficiency effect from the HCO<sub>3</sub><sup>-</sup> toxicity effect on shoot growth of bean, *Phaseolus vulgaris* L. 'Poncho', grown in hydroponics with a 2.5, 5, and 7.5 mM K<sup>+</sup> and Na<sup>+</sup> total concentration.

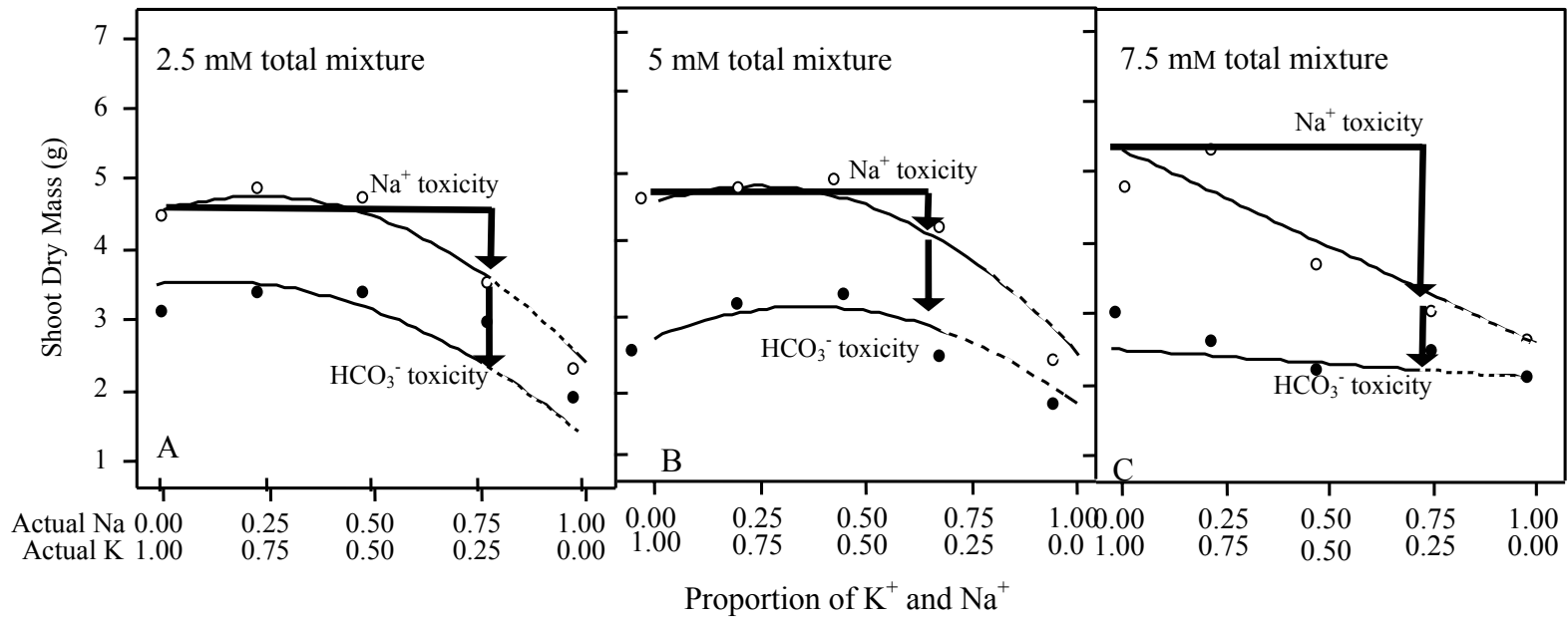
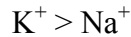

Fig. 6.31. Separation of the Na<sup>+</sup> toxicity effect from the HCO<sub>3</sub><sup>-</sup> toxicity effect on shoot growth of bean, *Phaseolus vulgaris* L. 'Poncho', grown in hydroponics with a 2.5, 5, and 7.5 mM K<sup>+</sup> and Na<sup>+</sup> total concentration.

5 mM total mixture

*Counter-Cation Effect.* In the 5 mM total mixture, shoot dry mass responded to the proportion of counter-cations according to the ranking (Fig. 6.24B)(high to low growth; high to low toxicity):



in mixtures with or without  $HCO_3^-$  (Fig. 6.24B). Similar to the 2.5 total mixture, this indicated that  $Na^+$  had a negative effect of plant growth.

*HCO<sub>3</sub><sup>-</sup> Effect.* Compared to the 2.5 mM total mixture, 5 mM  $HCO_3^-$  had a greater inhibition in shoot growth. The effect of the proportions of  $K^+$  and  $Na^+$  combined with  $HCO_3^-$  followed a curvilinear trend similar at both 2.5 and 5 mM total mixtures (Fig. 6.24A and B).

Compared to the reference point (the  $K^+$  pure blend, 1:0, containing no  $HCO_3^-$ ),  $Na^+$  induced a 44% shoot mass decrease; the addition of  $HCO_3^-$  caused an additional 16% decrease (Table 6.31 and 6.50, Fig. 6.24B).

Comparing the decrease in shoot mass between the 2.5 to 5 mM  $HCO_3^-$ , it was clear that in the 5 mM total mixture,  $Na^+$  did not increase its harmful effect since the decrease was very similar, 47% and 44% (Table 6.50), in spite of the higher concentration of  $Na^+$  in the 5 mM total mixture. Similarly, the increase in  $HCO_3^-$  concentration, from 2.5 to 5 mM, did not enhance the decrease in shoot mass (compare 15% with 2.5 mM to 16% with 5 mM). This implies that both counter-cation effect and  $HCO_3^-$  effect remain stable at 2.5 and 5 mM total mixtures.

*Separate  $Na^+$  and  $HCO_3^-$  Effect.* As discussed previously, to eliminate the  $K^+$  deficiency effect (Fig. 6.30B), the mixture  $1/4:3/4 K^+:Na^+$  was selected to delineate the separate effect of  $Na^+$  from the effect of  $HCO_3^-$  (Fig. 6.31B). As deduced from Table 6.50 and Fig. 6.31B, the combined effect of  $Na^+$  plus  $HCO_3^-$  at 5 mM, was a 41% reduction in shoot dry mass, but  $Na^+$  was responsible of only 17% decrease while  $HCO_3^-$  was responsible for the reminding 24%. These results are very similar to those reported in Experiment 6.3 (Table 6.17) and in the 2.5 mM total mixture (Table 6.50).

7.5 mM total mixture

*Counter-Cation Effect.* In the 7.5 mM total mixture, shoot dry mass responded to the proportion of counter-cations according to the ranking (Fig. 6.24C)(high to low growth; high to low toxicity):

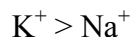

in solutions with no  $HCO_3^-$ , but in solutions containing  $HCO_3^-$  the ranking was (high to low growth; high to low toxicity):

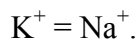

This indicated that there was toxic effect of  $Na^+$  in mixtures containing no  $HCO_3^-$ , but  $Na^+$  did not cause further damage when  $HCO_3^-$  was added.

*HCO<sub>3</sub><sup>-</sup> Effect.* Compared to the 2.5 and 5 mM total mixtures, 7.5 mM  $HCO_3^-$  had a greater inhibition in shoot growth.

Compared to the  $K^+$  pure blend (1:0 reference point with no  $HCO_3^-$ ),  $HCO_3^-$  decreased shoot dry mass by 50%; with  $Na^+$ , shoot mass was decreased 54%, and with the blend of  $Na^+$  and  $HCO_3^-$  by 58% (Table 6.37, Fig. 6.24C).

Comparing the decrease in shoot mass between the 2.5, 5, and 7.5 mM  $HCO_3^-$ ,  $Na^+$  and  $HCO_3^-$  slightly increased their harmful effect in the 7.5 mM compared to the 2.5 and 5 mM total mixtures (Fig. 6.24), despite the higher concentration of both. Nonetheless,  $Na^+$  seemed to have a more toxic effect since the decrease in shoot mass followed a linear trend. The decrease was 47%, 44% and 54% for the 2.5, 5, and 7.5 mM total mixtures (Table 6.50). This was due to the higher concentration of  $Na^+$ .

Surprisingly, the increase in  $HCO_3^-$  concentration did not enhance the decrease in shoot mass (compare 15% with 2.5 mM to 16% with 5 mM, and 4% with 5.5 mM). This implies that counter-cation toxic effect,  $Na^+$ , was higher than the  $HCO_3^-$ .

In the 7.5 mM total mixture, the results showed similar tendency as reported for the 0:1:0, 0:<sup>1</sup>/<sub>2</sub>:<sup>1</sup>/<sub>2</sub>, and 0:0:1  $Rb^+ : K^+ : Na^+$  mixtures of Experiment 6.3 (Fig. 6.8). There was a strong  $Na^+$  inhibiting effect when no  $HCO_3^-$  was added to the mixtures (compare Fig. 6.8 and 6.24C).

*Separate Na<sup>+</sup> and HCO<sub>3</sub><sup>-</sup> Effect.* As discussed previously, to eliminate the K<sup>+</sup> deficiency effect (Fig. 6.30C), the mixture <sup>1</sup>/<sub>4</sub>:<sup>3</sup>/<sub>4</sub> K<sup>+</sup>:Na<sup>+</sup> was selected to delineate the separate effect of Na<sup>+</sup> from the effect of HCO<sub>3</sub><sup>-</sup> (Fig. 6.31C). As deduced from Table 6.50 and Fig. 6.31C, the combined effect of Na<sup>+</sup> plus HCO<sub>3</sub><sup>-</sup> at 7.5 mM, was a 56% reduction in shoot dry mass. Sodium was responsible of 41% of the decrease while HCO<sub>3</sub><sup>-</sup> was responsible for the reminding 15%. This demonstrates that the HCO<sub>3</sub><sup>-</sup> effect was comparable to that obtained in the 2.5 and 5 mM total mixtures.

#### *Root growth*

Root mass was unaffected by the concentration of HCO<sub>3</sub><sup>-</sup> at 2.5 and 5 mM total mixtures, but in the 7.5 mM total mixture, root growth increased in response to HCO<sub>3</sub><sup>-</sup> (Fig. 6.25), primarily as the proportion of Na<sup>+</sup> approached to <sup>1</sup>/<sub>2</sub>. This is not in agreement to evidence demonstrating inhibition of root growth with increased HCO<sub>3</sub><sup>-</sup>, as reported in sugar beet (Campbell and Nishio, 2000) and grapevine plants treated with a solution of pH 8.5 and 10 mM HCO<sub>3</sub><sup>-</sup> (Römheld, 2000). In most cases, Na<sup>+</sup> and salinity also have a detrimental effect on root growth, as reported in wheat (Botella et al., 1997), sunflower (Delgado and Sanchez-Raya, 1996), carthamus (Gadallah, 1996), and rice (Lin and Kao, 1996; Lin and Kao, 1999).

Increase and no negative effect in root dry mass due to HCO<sub>3</sub><sup>-</sup> have also been reported. Peach rootstocks and olive plants maintained or increased the weight of roots when treated either with 10 mM HCO<sub>3</sub><sup>-</sup> or Fe stress (De la Guardia and Alcántara, 2002). Sensitive and tolerant pea cultivars also increased root mass when treated with solutions containing HCO<sub>3</sub><sup>-</sup> (Zribi and Gharsalli, 2002). Substantial increase in the number and elongation rate of root hairs was observed in tomato Fe- and P-deprived plants (Schikora and Schmidt, 2002).

#### *Effect of HCO<sub>3</sub><sup>-</sup> in the K<sup>+</sup> and Na<sup>+</sup> uptake*

Compared to 0 HCO<sub>3</sub><sup>-</sup> treatments, adding HCO<sub>3</sub><sup>-</sup> to the mixtures increased net uptake of Na<sup>+</sup> and K<sup>+</sup> by 100% and 31%, respectively, in the <sup>1</sup>/<sub>2</sub>:<sup>1</sup>/<sub>2</sub> mixture. The increase in K<sup>+</sup> and Na<sup>+</sup> uptake was 20% in the 0:1 and 1:0 K<sup>+</sup>:Na<sup>+</sup> mixtures (Fig. 6.29).

The higher  $\text{Na}^+$  uptake may have been a contributing factor to the detrimental effect of  $\text{HCO}_3^-$  in bean plants.

The increased  $\text{K}^+$  uptake in plants exposed to  $\text{HCO}_3^-$  (Fig. 6.29) is in agreement to many reports presenting evidence that  $\text{K}^+$  content increased in  $\text{HCO}_3^-$ -treated plants, such as in non-tolerant sunflower plants (Alcántara et al., 1988), white lupinus (Bertoni et al., 1992), celery (Tremblay et al., 1989), tobacco (Pearce et al., 1999b), peach (Alcántara et al., 2000) and tomato (Bialczyk et al., 1994). However, there also reports indicating that the content of  $\text{K}^+$  was decreased in tobacco (Pearce et al., 1999b), mums (Kramer and Peterson, 1990), maize, sorghum and beans (Alhendawi et al., 1997), rice (Yang et al., 1993) and roses (Fernández-Falcón et al., 1986).

Despite the increase in  $\text{K}^+$  uptake, there was a relative decrease in the  $\text{K}^+$  taken up per unit of  $\text{Na}^+$  taken, known as the  $\text{K}^+/\text{Na}^+$  uptake ratio. In the  $1/2:1/2$   $\text{K}^+:\text{Na}^+$  mixture, the  $\text{K}^+/\text{Na}^+$  uptake ratio decreased from 3/1 in plants grown with no  $\text{HCO}_3^-$  to 2/1 in  $\text{HCO}_3^-$  treated plants (Fig. 6.29). This relative decrease in  $\text{K}^+$  absorption in bean could be the result of a competition with  $\text{Na}^+$  present in the solution, as reported in bean plants by Carbonell-Barrachina et al. (1997). The relative increase in  $\text{Na}^+$  uptake causes a decrease  $\text{K}^+$  uptake because of its antagonist relationship, causing  $\text{K}^+$  deficiency and growth inhibition (Haro et al., 1993). An increase in  $\text{Na}^+$  uptake and decrease in  $\text{K}^+$  uptake has been reported in safflower *carthamus* as salinity increases (Gadallah, 1996).

#### *Water uptake*

The decrease in water uptake followed a pattern similar to shoot growth parameters (Fig. 6.28). The decrease in water uptake in plants grown in mixtures with a high proportion of  $\text{Na}^+$  may be due to the lower demand of the stressed plants. However, it is also possible that it was due to a higher concentration of salts, which caused an osmotic stress and decrease in water availability, as demonstrated in soil-grown plants (Dudley, 1994). Decreased water uptake and transpiration rate in soybean plants grown in  $\text{NaCl}$  at 40 mM has also been reported (An et al., 2002).



### *Shoot:root ratio*

Bicarbonate affected shoot mass at a higher extent compared to root mass, which explains the decreased shoot:root ratio (Table 6.27, 6.31, and 6.35). Similar results have been reported in bean plants (Sibole et al., 2000). In tomato, salinity affected root growth less than shoot growth, causing a lower root:shoot dry weight ratio (Cuartero and Fernández-Muñoz, 1999). Bicarbonate has also been reported to cause decreased shoot:root ratio due to either a decrease in shoot growth (Zribi and Gharsalli, 2002), or an enhanced root growth (De la Guardia and Alcántara, 2002).

The decrease in the shoot:root ratio may be accompanied by changes in the allocation of assimilates between root and shoot (Cuartero and Fernandez-Muñoz, 1999). The decreased shoot:root ratio is explained by De la Guardia and Alcántara (2002) by an increase in the concentration of organic acids, such as malate and citrate as a consequence of the cytoplasmic alkalinization and the induction of the pH stat mechanism. An increase in the PEP carboxylase activity in conditions of low Fe and the production of more acids through the CO<sub>2</sub> dark fixation is another hypothesis (De la Guardia and Alcántara, 2002). Another hypothesis is that there is an increase in the partitioning of assimilates to the roots due to the limited shoot growth under Fe deficiency, so photosynthates from the lower leaves are directed in higher proportion to the roots.

### *Conclusions*

The effect of the counter-cation and the HCO<sub>3</sub><sup>-</sup> was separated. At concentrations of 2.5 and 5 mM, the Na<sup>+</sup> effect was a 17 to 19% shoot growth decrease when K<sup>+</sup> deficiency effect was eliminated. The effect of HCO<sub>3</sub><sup>-</sup> caused an additional 19% to 24 % to the decrease in shoot mass. At 7.5 mM, the Na<sup>+</sup> effect surpassed the effect of HCO<sub>3</sub><sup>-</sup>. Sodium reduced shoot growth by 41%, while the addition of HCO<sub>3</sub><sup>-</sup> caused an additional 15% decrease. In general, we conclude that HCO<sub>3</sub><sup>-</sup> causes on average a 19% decrease in shoot growth. The counter-cation effect on shoot growth depends on its concentration. At high concentration the counter-cation reduced growth by 41%, but at lower concentrations, 2.5 to 5 mM, it was 18% on average.

## SUMMARY

The objective of this series of experiments was to study the effect of  $\text{HCO}_3^-$  on growth of bean plants. In order to control accurately the nutrients supplied as well as the concentration of  $\text{HCO}_3^-$ , these experiments were established in hydroponics. A major problem was that by incorporating  $\text{HCO}_3^-$  to the nutrient solution, a counter-cation of  $\text{HCO}_3^-$  must be used. Most studies performed to investigate the effect of alkalinity on plant growth have been carried out by using  $\text{Na}^+$  as the counter-cation of  $\text{HCO}_3^-$ . Few studies have used  $\text{K}^+$  as the counter-cation. Many authors have ignored the effect that both counter-cations and it has been assumed that  $\text{Na}^+$  and  $\text{K}^+$  do not interfere on the response of plants to  $\text{HCO}_3^-$ . Nonetheless, since  $\text{Na}^+$  may be toxic and  $\text{K}^+$  is a plants nutrient, the effect of  $\text{HCO}_3^-$  is confounded with the effect of the counter-cations. Due to the previous remarks, it was decided to initiate a series of experiments to separate the effect of the counter-cation from the effect of  $\text{HCO}_3^-$ .

In order to separate the counter-cation effect from the  $\text{HCO}_3^-$  effect it was decided to design the experiments as mixtures experiments. This was because some solutions can not be formulated in case a factorial experiment approach would have been taken. For instance, a solution containing 0 mM  $\text{Na}^+$ , 0 mM  $\text{K}^+$ , and 7.5 mM  $\text{HCO}_3^-$  can not be prepared since the sources of  $\text{HCO}_3^-$  are  $\text{NaHCO}_3$  and  $\text{KHCO}_3$ . The addition of 7.5 mM of  $\text{HCO}_3^-$  implies the addition of 7.5 mM of either  $\text{Na}^+$  or  $\text{K}^+$ .

The use of mixtures experiments allowed separating the counter-cation effect from the  $\text{HCO}_3^-$  effect by preparing a mixture of counter-cations at any given concentration of  $\text{HCO}_3^-$ .

Mixture experiments are also useful when formulating nutrient solutions, since similar problems are faced. For example, some solutions are impossible due to chemical precipitation (de Rijck and Schrevens, 1995 and 1999). In this case, mixture experiments allow making inferences only in the region of the response surface that the researcher considers adequate, a region with not chemical precipitation.

It is well known that numerous different nutrient solutions may yield similar results. Thus, plants can adapt to wide ranges in nutrient composition, implying a waste

of fertilizers or nutrients. It seems that nutrient solutions have been chosen based on trial and error approaches or in intuitive arguments (Schrevens and Cornell, 1993). The mixture theory permits the identification of a mineral composition that gives optimal growth, production and quality of products (de Rijck and Schrevens, 1995), hence waste is reduced.

An additional advantage of mixture experiments is the necessity of a limited number of experimental units to investigate a large experimental region, resulting in cheaper, faster, and easier experimentation (de Rijck and Schrevens, 1995).

Table 6.51 presents a summary of the results from experiments 6.3 and 6.6. In order to avoid the probable  $K^+$  deficiency effect, only the design points at which this nutrient was present at adequate concentration was considered. Eliminating this  $K^+$  deficiency effect, two types of response are identified. One is at low-to-intermediate levels of  $Na^+$  and the other is a high level of  $Na^+$ . At low-to-intermediate concentration, 1.88, 2.5 and 3.75 mM,  $Na^+$  induced a reduced shoot growth of 19%, 16%, and 17%, respectively (average decrease was 17%). At this levels of  $Na^+$ ,  $HCO_3^-$  induced shoot growth decrease of 19%, 22%, and 24% when  $HCO_3^-$  concentration was 2.5, 2.5, and 5 mM (average decrease was 22%). As deduced from these figures,  $Na^+$  and  $HCO_3^-$  induce, independently, approximately same growth decrease.

At high concentration, 5.6 mM,  $Na^+$  induced a decrease on shoot growth that exceeded the toxic effects of  $HCO_3^-$ . The decreased growth induced by  $Na^+$  was 41% while  $HCO_3^-$  induced a 15% decrease. Thus, the toxic effect of  $Na^+$  is higher than that of  $HCO_3^-$  when the concentration of  $Na^+$  is 5.6 mM. It is interesting to notice that the decrease due to  $HCO_3^-$  is still in agreement to that obtained at low-to-intermediate concentration of  $Na^+$ .

Rubidium seems to be extremely toxic only when its concentration was 7.5 mM. In the centroid design point, 2.5 mM  $Rb^+$ , it did not induce toxicity.

Table 6.51. Summary of the percentage decrease in shoot dry mass due to the effect of the counter-cations,  $\text{HCO}_3^-$ , and interactions.

Cation Concentration (mM)	$\text{HCO}_3^-$ (mM)	Effect	Figure	Response surface Location	Shoot mass decrease
1.88	0	$\text{Na}^+$ toxicity	6.31A	$\text{Na}^{+z}$	19%
2.5	0	$\text{Na}^+$ toxicity/ $\text{K}^+$ deficiency	6.30A	$\text{Na}^+$ vertex	47%
2.5+2.5	0	$\text{Rb}^+ + \text{Na}^+$ toxicity	6.17	Centroid	16%
3.75	0	$\text{Na}^+$ toxicity	6.31B	$\text{Na}^{+y}$	17%
5	0	$\text{Na}^+$ toxicity/ $\text{K}^+$ deficiency	6.30B	$\text{Na}^+$ vertex	44%
5.6	0	$\text{Na}^+$ toxicity	6.31C	$\text{Na}^{+x}$	41%
7.5	0	$\text{Na}^+$ toxicity/ $\text{K}^+$ deficiency	6.15	$\text{Na}^+$ vertex	19%
7.5	0	$\text{Rb}^+$ toxicity/ $\text{K}^+$ deficiency	6.16	$\text{Rb}^+$ vertex	30%
7.5	0	$\text{Na}^+$ toxicity/ $\text{K}^+$ deficiency	6.30C	$\text{Na}^+$ vertex	54%
2.5	2.5	$\text{HCO}_3^-$	6.30A	$\text{Na}^+$ vertex	15%
1.88	2.5	$\text{HCO}_3^-$	6.31A	$\text{Na}^{+z}$	19%
5	5	$\text{HCO}_3^-$	6.30B	$\text{Na}^+$ vertex	16%
3.75	5	$\text{HCO}_3^-$	6.31B	$\text{Na}^{+y}$	24%
7.5	7.5	$\text{HCO}_3^-$	6.15	$\text{Na}^+$ vertex	15%
7.5	7.5	$\text{HCO}_3^-$	6.16	$\text{Rb}^+$ vertex	18%
2.5+2.5	7.5	$\text{HCO}_3^-$	6.17	Centroid	22%
7.5	7.5	$\text{HCO}_3^-$	6.30C	$\text{Na}^+$ vertex	4%
5.6	7.5	$\text{HCO}_3^-$	6.31C	$\text{Na}^{+x}$	15%

<sup>z</sup> Mixtures  $3/4:1/4 \text{K}^+:\text{Na}^+$

<sup>y</sup> Mixtures  $3/4:1/4 \text{K}^+:\text{Na}^+$

<sup>x</sup> Mixtures  $3/4:1/4 \text{K}^+:\text{Na}^+$

## CHAPTER VII

### SUMMARY

#### TOLERANCE TO ALKALINITY IN SELECTED GREENHOUSE PLANTS

Tolerance to alkalinity in irrigation water was evaluated in four greenhouse ornamental species; rose 'Pink Cupido', vinca 'Apricot Delight', chrysanthemum 'Miramar', and hibiscus 'Bimini Breeze' and 'Mango Breeze'. Plants were potted in a sphagnum peat-based growing medium with an initial pH of 6.3 and were irrigated with solutions containing 0, 2.5, 5, 7.5, and 10 mM NaHCO<sub>3</sub> for 12 weeks. The maximum concentration of NaHCO<sub>3</sub> tolerated by plants was determined by estimating maximum shoot dry mass and SPAD index, according to the linear or quadratic model that best fit the results. For most species, the maximum shoot dry mass and SPAD index was at 0 mM NaHCO<sub>3</sub> control treatment. Some species exhibited a maximum shoot dry mass and SPAD index at low NaHCO<sub>3</sub> concentrations. A 15% decrease from the maximum shoot dry mass and SPAD index was considered the threshold to declare the toxic concentration of NaHCO<sub>3</sub>. The 15% decrease was calculated based on the maximum shoot mass or SPAD index predicted by the models. The concentration of NaHCO<sub>3</sub> at which 15% decrease occurred was estimated by using the models.

In chrysanthemum, despite the non-significant decrease in shoot mass, a severe increase in leaf chlorosis when irrigated with solutions containing 5 mM NaHCO<sub>3</sub> indicated sensitivity to alkalinity; its toxic level was set at 4.1 mM. In rose, decreased shoot mass and increased chlorosis were significant when plants were irrigated with 5 mM NaHCO<sub>3</sub> compared to control plants; its toxic level was set at 1.1 mM NaHCO<sub>3</sub>. In Vinca, 2.5 mM NaHCO<sub>3</sub> was permanently associated with a 20% to 25% decrease in leaf growth parameters, but shoot fresh and dry mass were unaffected by increasing concentrations of NaHCO<sub>3</sub>; nonetheless, 5 mM caused a significant chlorosis on the top leaves. Toxic levels for vinca were set at 6.7 mM.

Growth of hibiscus 'Mango Breeze' increased slightly and significantly when irrigated with 2.5 and 5 mM  $\text{NaHCO}_3$ , so some alkalinity in water was beneficial for this cultivar. Hibiscus 'Bimini Breeze' exhibited a high tolerance to elevated concentrations of  $\text{NaHCO}_3$  since the levels of alkalinity assessed in this experiment did not affect shoot growth and leaf chlorosis decreased to a lesser extent compared to hibiscus 'Mango Breeze'. The toxic levels were 3.1 and 6.3 mM, for hibiscus 'Mango Breeze' and 'Bimini Breeze' respectively.

Growing medium pH increased with increasing levels of  $\text{NaHCO}_3$ , although all plant species showed varying capacities of acidification in control treatments. The acidification capacity was lost as alkalinity reached the highest levels, which may explain the increased chlorosis due to decreased Fe solubility.

#### **RESPONSE OF TWO CULTIVARS OF HIBISCUS TO ALKALINITY IN IRRIGATION WATER**

Tolerance to alkalinity in irrigation water was evaluated in two cultivars of hibiscus, 'Bimini Breeze' and 'Carolina Breeze', grown in sphagnum peat moss-based growing medium or in hydroponics. The objective was to investigate the mechanisms of tolerance of hibiscus 'Bimini Breeze' to alkalinity observed in previous experiment. In hydroponics, plants were transferred to a 9 L tray containing a modified Hoagland's nutrient solution prepared with various  $\text{NaHCO}_3$  concentrations.

The response of both cultivars of hibiscus varied according to concentration of  $\text{NaHCO}_3$  in irrigation water or nutrient solution. In soilless culture, shoot growth remained unaffected in hibiscus 'Bimini Breeze', but hibiscus 'Carolina Breeze' was more affected as indicated by the significant decrease in shoot dry mass with 7.5 and 10 mM  $\text{NaHCO}_3$ . Hibiscus 'Carolina Breeze' was slightly benefited by low levels of alkalinity. In hydroponics, increasing concentration of  $\text{NaHCO}_3$  induced severe decrease in shoot growth in both cultivars.

Root growth was markedly affected by increasing concentrations of  $\text{NaHCO}_3$ . Hibiscus 'Bimini Breeze' was more affected because the maximum decrease in root dry mass was around 50%, whereas in hibiscus 'Carolina Breeze' it was 39%. In

hydroponics, the loss of root mass was also more accentuated in hibiscus ‘Bimini Breeze’, 80%, while in Carolina Breeze it remained at 39%.

The accumulation of  $\text{NaHCO}_3$  caused an increase in growing medium pH in container cultured plants. The increase in pH was less pronounced in hibiscus ‘Bimini Breeze’ compared to ‘Carolina Breeze’, indicating a higher capacity of acidification by hibiscus ‘Bimini Breeze’. Cultivars did not differ in acidification capacity when grown in hydroponics, but considering the more severe loss of root mass in ‘Bimini Breeze’, it is concluded that this cultivar has higher acidification ability.

Newly-developed leaves showed increasing chlorosis due to increasing concentration of  $\text{NaHCO}_3$ . Hibiscus ‘Bimini Breeze’ was more tolerant to  $\text{NaHCO}_3$  since 7.5 mM  $\text{NaHCO}_3$  was required to induce a significant increase of chlorosis, while for Carolina Breeze, it was at 5 mM.

Root diameter was unaffected in hibiscus ‘Bimini Breeze’, but in ‘Carolina Breeze’ there was a significant increase, especially at concentrations of 7.5 and 10 mM.

The activity of Fe-reductase decreased when plants were grown in 5 mM  $\text{NaHCO}_3$  in hibiscus ‘Carolina Breeze’, but in ‘Bimini Breeze’ the enzymatic activity was enhanced as the concentration of  $\text{NaHCO}_3$  increased.

In conclusion, hibiscus ‘Bimini Breeze’ was more tolerant of high levels of alkalinity than ‘Carolina Breeze’. Plant growth of hibiscus ‘Carolina Breeze’ was benefited from small amounts of  $\text{NaHCO}_3$  in the latter.

The maximum concentration of  $\text{NaHCO}_3$  tolerated by both cultivars was determined by estimating the maximum shoot dry mass and SPAD index, according to the linear or quadratic model that best fit the results. A 15% decrease from the maximum shoot dry mass and SPAD index was considered the threshold to declare the toxic concentration of  $\text{NaHCO}_3$ . The 15% decrease was calculated based on the maximum shoot mass or SPAD index predicted by the models. The concentration of  $\text{NaHCO}_3$  at which 15% decrease occurred was estimated by using the models.

Maximum shoot growth was estimated to occur at 0 and 2.21 mM in hibiscus ‘Bimini Breeze’ and ‘Carolina Breeze’, respectively, although root mass in the latter was

affected. The limits of toxicity, based on SPAD index decrease, were set at 6.7 and 3.0 mM NaHCO<sub>3</sub>, respectively. Tolerance in hibiscus 'Bimini Breeze' was due to an enhanced activity of Fe-reductase in plants grown under high levels of alkalinity and higher acidification rate when grown in soilless medium.

### **EFFECT OF THE NO<sub>3</sub><sup>-</sup> : NH<sub>4</sub><sup>+</sup> RATIO IN THE RESPONSE OF SUNFLOWER TO ALKALINITY**

Sunflower 'Big Smile' plants were grown in hydroponics with a modified Hoagland's nutrient solution. Five NO<sub>3</sub><sup>-</sup> : NH<sub>4</sub><sup>+</sup> ratios were evaluated in combination with or without 5 mM NaHCO<sub>3</sub>. The NO<sub>3</sub><sup>-</sup> : NH<sub>4</sub><sup>+</sup> ratios were: 1:0, 0.75:0.25, 0.5:0.5, 0.25:0.75, and 0:1. Total N concentration was 15 mM.

In solutions containing a 1 NO<sub>3</sub><sup>-</sup> : 0 NH<sub>4</sub><sup>+</sup> ratio, initial pH increased when shoot elongation started. In solutions containing 25% to 100% NH<sub>4</sub><sup>+</sup>-N, acidification occurred by the end of the second week, which was more marked as the proportion of NH<sub>4</sub><sup>+</sup> increased.

Sunflower plants were unable to acidify the nutrient solution significantly to neutralize the alkalinity effect of HCO<sub>3</sub><sup>-</sup> in solutions containing 5 mM NaHCO<sub>3</sub> and 1 NO<sub>3</sub><sup>-</sup> : 0 NH<sub>4</sub><sup>+</sup> ratio. In plants grown in solutions containing a 0.75:0.25 ratio and NaHCO<sub>3</sub>, acidification capacity was exhibited for around 5 days, but after this periods, pH returned back to 8.12. In plants fed with 0.5:0.5, 0.25:0.75, and 0:1 NO<sub>3</sub><sup>-</sup> : NH<sub>4</sub><sup>+</sup> ratios, solution pH was gradually acidified but the acidification rate was faster with no NaHCO<sub>3</sub> in solution.

The NaHCO<sub>3</sub>-induced alkalinity favored the reaction of NH<sub>4</sub><sup>+</sup> to produce NH<sub>3</sub>, which reached toxic levels at proportions of NH<sub>4</sub><sup>+</sup>-N higher than 50% and caused death in exclusively NH<sub>4</sub><sup>+</sup>-N fed plants. In plants treated with no NaHCO<sub>3</sub>, increasing proportions of NH<sub>4</sub><sup>+</sup>-N resulted in growth inhibition. The most favorable NO<sub>3</sub><sup>-</sup> : NH<sub>4</sub><sup>+</sup> ratio in sunflower plants grown with NaHCO<sub>3</sub> was 0.75:0.25. Under this treatment, shoot mass was 40% higher than the mass of plants grown in the 1 NO<sub>3</sub><sup>-</sup> : 0 NH<sub>4</sub><sup>+</sup> ratio, thus implying that a low concentration of NH<sub>4</sub><sup>+</sup>-N imparts some tolerance to plants grown under high alkalinity. With no addition of NaHCO<sub>3</sub>, maximum growth was



observed at the 1  $\text{NO}_3^-$  : 0  $\text{NH}_4^+$  ratio, which was 21% higher than that at the 0.75  $\text{NO}_3^-$  : 0.25  $\text{NH}_4^+$  ratio.

### **EFFECT OF COUNTER-IONS OF BICARBONATE ON BEAN PLANTS**

The interaction between  $\text{HCO}_3^-$  and several counter-cations was studied in bean plants established in hydroponics. The effects of  $\text{Rb}^+$ ,  $\text{Cs}^+$ ,  $\text{K}^+$ ,  $\text{Na}^+$ , and  $\text{NH}_4^+$  in combination with a number of  $\text{HCO}_3^-$  concentrations were evaluated on bean plants using mixtures of two or three of the counter-cations in a series of experiments set up in controlled environmental chamber. Mixtures experiments were used to analyze the interaction among ions.

Ammonium had both beneficial and detrimental effects, depending on its concentration. A concentration of  $\text{NH}_4^+$  below 1.66 mM was associated with a higher shoot mass, but higher concentrations inhibited growth. This could be caused by the reaction of  $\text{NH}_4^+$  with  $\text{HCO}_3^-$  under alkaline conditions to produce  $\text{NH}_3$ , which becomes toxic at high concentrations. At low concentration of  $\text{NH}_4^+$ , the reaction might be enough to reduce the buffer capacity of  $\text{HCO}_3^-$ , mitigating in this way its detrimental effect. Nitrification may have also decreased solution pH and neutralized the buffer capacity of  $\text{HCO}_3^-$ .

Rubidium and  $\text{Cs}^+$  induced toxicity in bean plants. Cesium inhibited plant growth at any concentration, causing plant death. Rubidium had a deleterious effect when its concentration was above 5 mM. The harmful effect of  $\text{Rb}^+$  occurred with or without  $\text{HCO}_3^-$ , but it was not further increased by alkalinity, implying that the stress caused by the interaction of  $\text{Rb}^+$  and  $\text{HCO}_3^-$  was antagonistic.

Three component mixture experiment using  $\text{Rb}^+$ ,  $\text{K}^+$ , and  $\text{Na}^+$ , and two component mixture experiment using  $\text{K}^+$  and  $\text{Na}^+$ , were conducted to delineate the toxicity of  $\text{HCO}_3^-$  versus the counter-cation ( $\text{Rb}^+$ ,  $\text{K}^+$ , and  $\text{Na}^+$ ).

In order to avoid probable  $\text{K}^+$  deficiency effect, only the design points at which  $\text{K}^+$  was present at adequate concentration ( at least  $\frac{1}{4}$  of the cations) was consider. Two types of responses were identified. One at low-to-intermediate level of  $\text{Na}^+$  and the other at high level of  $\text{Na}^+$ . At low-to-intermediate concentration, 1.88, 2.5 and 3.75

mM,  $\text{Na}^+$  induced a reduced shoot growth of 19%, 16%, and 17%, respectively (average decrease was 17%). At this levels of  $\text{Na}^+$ ,  $\text{HCO}_3^-$  induced shoot growth decrease of 19%, 22%, and 24% when  $\text{HCO}_3^-$  concentration was 2.5, 2.5, and 5 mM (average decrease was 22%). Thus,  $\text{Na}^+$  and  $\text{HCO}_3^-$  induced approximately same growth decrease.

At high concentration, 5.6 mM,  $\text{Na}^+$  induced a decrease on shoot growth that exceeded the toxic effects of  $\text{HCO}_3^-$ . The decrease induced by  $\text{Na}^+$  was 41% while  $\text{HCO}_3^-$  induced 15% decrease. Thus, the toxic effect of  $\text{Na}^+$  is higher than that of  $\text{HCO}_3^-$  when the concentration of the former was 5.6 mM. The decrease due to  $\text{HCO}_3^-$  was still in agreement to that obtained at low-to-intermediate concentration of  $\text{Na}^+$ .

Bicarbonate induced a decrease in the  $\text{K}^+/\text{Na}^+$  net uptake, which resulted in a relatively higher uptake of  $\text{Na}^+$ . This suggests that the growth reduction observed at the highest concentration of  $\text{HCO}_3^-$  may have been caused by an excess in  $\text{Na}^+$  uptake.

## LITERATURE CITED

- Abdelloui A. and A. Talouizte. 2001. Effect of previous nitrogen starvation on  $\text{NO}_3^-$  and  $\text{NH}_4^+$  uptake and assimilation associated with the endogenous soluble carbohydrate utilization in Moroccan wheat seedlings. *Journal of Plant Nutrition*. 24:1995-2007.
- Alcántara, E., F.J. Romera, M. Cañete, and M.D. de la Guardia. 2000. Effects of bicarbonate and iron supply on Fe(III) reducing capacity of root and leaf chlorosis of the susceptible peach rootstock 'Nemaguard'. *Journal of Plant Nutrition*. 23:1607-1617.
- Alcántara, E., F.J. Romera, and M.D. de la Guardia. 1988. Genotypic differences in bicarbonate-induced iron chlorosis in sunflower. *Journal of Plant Nutrition*. 11:65-67.
- Alhendawi R.A., V. Römheld, E.A. Kirkby, and H. Marschner. 1997. Influence of increasing bicarbonate concentrations on plant growth, organic acid accumulation in roots and iron uptake by barley, sorghum and maize. *Journal of Plant Nutrition*. 20:1731-1753.
- An, P., S. Inanaga, Y. Cohen, U. Kafkaki, and Y. Sugimoto. 2002. Salt tolerance in two soybean cultivars. *Journal of Plant Nutrition*. 25:407-423.
- Argo, W.R. and J.A. Bierbaum. 1996. The effect of lime, irrigation-water source, and water-soluble fertilizer on root-zone pH, electrical conductivity, and micronutrient management of container root media with impatiens. *Journal of the American Society for Horticultural Science*. 121:442-452.
- Argo, W., J.A. Bierbaum, and D.D. Warncke, 1997. Geographical characterization of greenhouse irrigation water. *Hort Technology*. 7:49-55.
- Arteca, R.N., B.W. Poovaiah, and O.E. Smith. 1980. Changes in carbon fixation, tuberization and growth induced by  $\text{CO}_2$  applications to the root zones of potato plants. *Science*. 205:1279-1280.
- Ayers, R.S. and D.W. Westcot. 1976. Water quality for agriculture. Food and Agriculture Organization of the United Nations, Rome.
- Bailey, D.A. 1996. Alkalinity and acidification. P. 69-91. In: Reed, D.Wm. (ed.). *Water, media and nutrition*. Ball Publishing, Batavia, IL.

- Bailey, D.A. and P.A. Hammer. 1986. Growth and nutritional status of petunia and tomato seedlings with acidified water. *HortScience*. 21:423-425.
- Barber, S.A. 1995. Soil nutrient bioavailability. A mechanistic approach. 2<sup>nd</sup> edition. John Wiley and Sons, NEW YORK.
- Bavaresco, L., E. Giachino, and R. Colla. 1999. Iron chlorosis paradox in grapevine. *Journal of Plant Nutrition*. 22:1589-1597.
- Benlloc, M., I. Moreno, and A. Rodríguez-Navarro. 1989. Two modes of rubidium uptake in sunflower plants. *Plant and Soil*. 90:939-942.
- Ben-Oliel, G. and U. Kafkati. 2002. Melon fruit quality as affected by timing, duration, and concentration of phosphate and nitrogen sources in recycled hydroponic system. *Journal of Plant Physiology*. 25:1563-1583.
- Bertoni, G.M., A. Pissaloux, P. Morad, and D.R. Sayag. 1992. Bicarbonate-pH relationship with iron chlorosis in white lupine. *Journal of Plant Nutrition*. 15:1509- 1518.
- Bialczyk, J. and Z. Lechowski. 1992. Absorption of  $\text{HCO}_3^-$  by roots and its effect on carbon metabolism of tomato. *Journal of Plant Nutrition*. 15:293-312.
- Bialczyk, J. and Z. Lechowski. 1995. Chemical composition of xylem sap of tomato grown on bicarbonate containing medium. *Journal of Plant Nutrition*. 18:2005-2021.
- Bialczyk, J., Z. Lechowski, and A. Libik. 1994. Growth of tomato seedlings under different  $\text{HCO}_3^-$  concentration in the medium. *Journal of Plant Nutrition*. 17:801-816.
- Bierbaum, J. 1994. A delicate balance. *Greenhouse Grower*. 12:88-94.
- Bingham, I.J. and E.A. Stevenson. 1993. Control of root growth: effects of carbohydrates on the extension, branching, and rate of respiration of different fractions of wheat roots. *Physiologia Plantarum*. 88:149-158.
- Blanke, M.M., W. Bacher, R.J. Pring, and E.A. Baker. 1996. Ammonium nutrition enhances chlorophyll and glaucousness in Kohlrabi. *Annals of Botany*. 78:599-604.
- Bloom, A.J., L.E. Jackson, and D.R. Smart. 1993. Root growth as a function of ammonium and nitrate in the root zone. *Plant and Cell Environment*. 16:199-206.

- Bloom, P.R. and W.P. Inskeep. 1986. Factors affecting bicarbonate chemistry and iron chlorosis in soils. *Journal of Plant Nutrition*. 9:215-228.
- Botella, M.A., V. Martinez, M. Nieves, and A. Cerda. 1997. Effect of salinity on the growth and nitrogen uptake by wheat seedlings. *Journal of Plant Nutrition*. 20:793-804.
- Campbell, S.A. and J.N. Nishio. 2000. Iron deficiency studies of sugar beet using an improved sodium bicarbonate-buffered hydroponic growth system. *Journal of Plant Nutrition*. 23:741-757.
- Carbonell-Barrachina, A.A., F. Burló-Carbonell, and J. Mataix-Beneyto. 1997. Effect of sodium arsenite and sodium chloride on bean plant nutrition (macronutrients). *Journal of Plant Nutrition*. 20:1617-1633.
- Cornell, J. 2002. Experiments with mixtures. Designs, models, and the analysis of mixture data. John Wiley and Sons, New York.
- Cornell, J.A. and J.M. Harrison. 1997. Models and designs for experiments with mixtures. Part II; Exploring a subregion of the simplex and the inclusion of other factors in mixture experiments. Bulletin 899. Agricultural Experiment Station. Institute of Food and Agricultural Sciences. University of Florida. Gainesville, FL.
- Cornell, J.A. and S.B. Linda. 1991. Methods and designs for experiments with mixtures. Part I; Exploring the whole simplex subregion. Bulletin 879. Agricultural Experiment Station. Institute of Food and Agricultural Sciences. University of Florida. Gainesville, FL.
- Cuartero, J. and R. Fernández-Muñoz. 1999. Tomato and salinity. *Scientia Horticulturae*. 78:83-125.
- De la Guardia, M.D. and E. Alcántara. 2002. Bicarbonate and low iron level increase root to total plant weight ratio in olive and peach rootstock. *Journal of Plant Nutrition*. 25:1021-1032.
- Delgado, I.C. and A.J. Sanchez-Raya. 1996. Effect of NaCl on some physiological parameters in sunflower (*Helianthus annuus* L.) seedlings. *Agrochimica*. 40:284-292.
- Dell'Orto, M., S. Samti, P. De Nis, S. Cesco, Z. Varanini, G. Zocchi, and R. Pinton. 2002. Development of Fe-deficiency responses in cucumber (*Cucumis sativus* L.) roots: involvement of plasma membrane H<sup>+</sup>-ATPase activity. *Journal of Experimental Botany*. 51:695-701.

- De Rijck, G. and E. Schrevens. 1995. Application of mixture-theory for the optimization of the composition of the nutrient solution. *Acta Horticulturae*. 401:283-291.
- De Rijck, G. and E. Schrevens. 1999. Chemical feasibility region for nutrient solutions in hydroponic plant nutrition. *Journal of Plant Nutrition*. 22:229-268.
- Dofing, S.M., E.J. Pena, and J.W. Maranville. 1989. Effect of bicarbonate on iron reduction by soybean roots. *Journal of Plant Nutrition*. 12:797-802.
- Dogar, M.A. and T. van Hai. 1980. Effect of N, P and  $\text{HCO}_3^-$  levels in the nutrient solution on rate of Zn absorption by rice roots and Zn content. *Zeitschrift fuer Pflanzenphysiologie*. 98: 203-212.
- Dole, J.M. 1994. Irrigation. p. 24-27. In: M.L. Gaston, P.S. Konjoian, S.A. Carver, C.A. Buck, and R.A. Larson. *Tips on growing and marketing hanging baskets*. Ohio Florists' Association, Columbus, OH.
- Dudley, L.M. 1994. Salinity in the environment. p. 13-30. In: M. Pessarali (ed.). *Handbook of plant and crop stress*. Marcel Dekker, New York.
- Eckhardt, U. and T.J. Buckhout. 2000. Analysis of the mechanism of iron assimilation in *Chlamydomonas reinhardtii*: a model system for strategy I plants. *Journal of Plant Nutrition*. 23:1797-1807.
- El-Sheikh, A.M. and A. Ulrich. 1970. Interactions of rubidium, sodium and potassium on nutrition of sugar beet plants. *Plant Physiology*. 46:645-649.
- El-Sheikh, A.M., A. Ulrich, and T.C. Boyer. 1967. Sodium and rubidium as possible nutrients for sugar beet plants. *Plant Physiology*. 42:1202-1208.
- Fernández Falcón, M., C.E. Alvarez González, V. García, and J. Báez. 1986. The effect of chloride and bicarbonate levels in irrigation water on nutrient content, production and quality of cut roses 'Mercedes'. *Scientia Horticulturae*. 29:373-385.
- Fleming, A.L., R.L. Cheney, and B.A. Coulombe. 1984. Bicarbonate inhibits Fe-stress response and Fe uptake-translocation of chlorosis-susceptible soybean cultivars. *Journal of Plant Nutrition*. 7:699-714.
- Flores, P., M. Carvajal, A. Cerdá, and V. Martínez. 2001. Salinity and ammonium/nitrate interactions on tomato plant development, nutrition, and metabolites. *Journal of Plant Nutrition*. 24:1561-1573.

- Forno, D.A., S. Yoshida, and C.J. Asher. 1975. Zinc deficiency in rice. II. Studies on two varieties differing in susceptibility to zinc deficiency. *Plant and Soil*. 42:551-563.
- Gadallah, M.A. 1996. Abscisic acid, temperature and salinity interactions on growth and some mineral elements in *Carthamus* plants. *Plant Growth Regulation*. 20:225-236.
- Gerandás, J., R.G. Ratcliffe, and B. Sattelmacher. 1990. <sup>31</sup>P nuclear magnetic resonance evidence for differences in intracellular pH in the roots of maize grown with nitrate or ammonium. *Journal of Plant Physiology*. 137:125-128.
- Ground, T.A. and A.W. Groeger. 1994. Chemical classification and trophic characteristics of Texas reservoirs. *Lake and Reservoir Management*. 10:189-201.
- Groeger, A.W. and J.J. Gustafson. 1994. Chemical composition and variability of the waters of the Edwards Plateau, central Texas. p. 39-46. In: J.A. Stanford and H.M. Valett (editors), *Proceedings of the Second International Conference on Ground Water Ecology*. American Water Resources Association, Herndon, VA.
- Hagström, J., W.M. James, and K.R. Skene. 2001. A comparison of structure, development and function of cluster roots of *Lupinus albus* L. under phosphate and iron stress. *Plant and Soil*. 232:81-90.
- Handreck, K. and N. Black. 2002. *Growing media for ornamental plants and turf*. UNSW Press, Sydney, Australia.
- Hara, T., Y. Sonoda, and I. Iwai. 1977. Growth response of cabbage plants to lithium, sodium, and rubidium under water culture. *Soil Science and Plant Nutrition*. 23:531-539.
- Haro, R., M.A. Bañuelos, F.J. Quintero, F. Rubio, and A. Rodríguez-Navarro. 1993. Genetic basis of sodium exclusion and sodium tolerance in yeast. A model for plants. *Physiologia Plantarum*. 89:868-874.
- Havlin. J.L., J.D. Beaton, S.L. Tisdale, and W.L. Nelson. 1999. *Soil fertility and fertilizers*. Prentice Hall, Upple Saddle River, NJ.
- Hawker, J.S., H. Marschner, and W.J.S. Dawnton. 1974. Effect of sodium and potassium on starch synthesis on leaves. *Australian Journal of Plant Physiology*. 1:491-501.

- Hughes, D.F., V.D. Jolley, and J.C. Brown. 1990. Differential response of dicotyledonous plants to potassium-deficiency stress –iron-stress response mechanism. *Journal of Plant Nutrition*. 13:1405-1417.
- Hughes, D.F., V.D. Jolley, and J.C. Brown. 1992. Roles for potassium in the iron-stress response mechanisms of strategy-I and strategy-II plants. *Journal of Plant Nutrition*. 15:1821-1839.
- Jeong, B.R. and C.W. Lee. 1992. Ammonium and nitrate nutrition of 11 bedding plant species. *Acta Horticulturae*. 319:505-510.
- Jeong, B.R. and C.W. Lee. 1996. Influence of ammonium, nitrate and chloride on solution pH and ion uptake by *ageratum* and *Salvia* in hydroponics culture. *Journal of Plant Nutrition*. 19:1343-1360.
- Kamminga-van Wijk, C. and H.B.A. Prins. 1993. The kinetics of  $\text{NH}_4^+$  and  $\text{NO}_3^-$  uptake by Douglas fir from single N-solutions and from solutions containing both  $\text{NH}_4^+$  and  $\text{NO}_3^-$ . *Plant and Soil*. 151:91-96.
- Kaya, C., D. Higgs, and A. Ikinici. 2002a. An experiment to investigate ameliorative effects of potassium sulphate on salt and alkalinity stressed vegetable crops. *Journal of Plant Nutrition*. 25:2545-2558.
- Kaya, C., D. Higgs, K. Saltali, and O. Gezerel. 2002b. Response of strawberry grown at high salinity and alkalinity to supplementary potassium. *Journal of Plant Nutrition*. 25:1415-1427.
- Kessler, J.R. 1999. Water quality management for greenhouse production. Alabama Cooperative Extension System, ANR-1158, Auburn, AL.
- Kim, T., H.A. Mills, and H.Y. Wetzstein. 2002. Studies on effects of nitrogen form on growth, development, and nutrient uptake in pecan. *Journal of Plant Nutrition*. 25:497-508.
- Kosegarten, H., F. Grolig, A. Esch, K-H. Glüsenkamp, and K. Mengel. 1999. Effects of  $\text{NH}_4^+$ ,  $\text{NO}_3^-$  and  $\text{HCO}_3^-$  on apoplast pH in the outer cortex of root zones of maize, as measured by the fluorescence ratio of fluorescein boronic acid. *Planta*. 209:444-452.
- Kosegarten, H., B. Hoffmann, and K. Mengel. 2001. The paramount influence of nitrate in increasing apoplastic pH of young sunflower leaves to induce Fe deficiency chlorosis, and the re-greening effect brought about by acidic foliar sprays. *Journal of Plant Nutrition and Soil Science*. 164:155-163.



- Kramer, L.L. and J.C. Peterson. 1990. Influences of water pH, alkalinity, and acid additions on the growth and nutrient relationships in *Chrysanthemum morifolium* 'Bright Golden Anne'. *Journal of Plant Nutrition*. 13:169-186.
- Kuehny, J.S. and B. Morales. 1998. Effects of salinity and alkalinity on pansy and impatiens in three different growing media. *Journal of Plant Nutrition*. 21:1011-1023.
- Lance, C. and P. Rustin. 1984. The central role of malate in plant metabolism. *Physiologia Vegetale*. 22:625-641.
- Larcher, W. 1975. *Physiological plant ecology*. Springer-Verlag, Berlin- Heilderberg, New York.
- Lasa, B., S. Frechilla, C. Lamsfus, and P.M. Aparicio-Tejo. 2001. The sensitivity to ammonium nutrition is related to nitrogen accumulation. *Scientia Horticulturae*. 91:143-152.
- Lee, J.A. and H.W. Woolhouse. 1969. A comparative study of bicarbonate inhibitions of root growth in calcicole and calcifuge grasses. *New Phytologist*. 68:1-11.
- Li, C-J., X-P. Zhu, and F-S Zhang. 2000. Role of shoot in regulation of iron deficiency responses in cucumber and bean plants. *Journal of Plant Nutrition*. 23:1809-1818.
- Lin, C.C. and C.H. Kao. 1996. Proline accumulation is associated with inhibition of rice seedling root growth caused by NaCl. *Plant Science*. 114:121-128.
- Lin, C.C. and C.H. Kao. 1999. NaCl induced changes in ionically bound peroxidase activity in roots of rice seedlings. *Plant and Soil*. 216:147-153.
- Lindsay, W.L. 1979. *Chemical equilibria in soils*. The Blackburn Press, Caldwell, NJ.
- Lindsay, W.L. and D.W. Thorpe. 1954. Bicarbonate and oxygen as related to chlorosis. *Soil Science*. 77:271-279.
- Lucena, J.L. 2000. Effects of bicarbonate, nitrate and other environmental factors on iron deficiency chlorosis. A review. *Journal of Plant Nutrition*. 23:1591-1606.
- Ludwig, L.S. 1985. Influences of water pH, alkalinity, acid additions upon floral crop growth and nutrient relationship. M.S. Thesis. The Ohio State University, Columbus, OH.

- Lunt, O.R., H.C. Kohl, and A.M. Kofranek. 1956. The effect of bicarbonate and other constituents of irrigation water on the growth of azaleas. *Proceedings of the American Society for Horticultural Science*. 68:537-544.
- Marschner, H. 1995. *Mineral nutrition of higher plants*. Academic Press, New York.
- Marschner H., V. Römheld, and M. Kissel. 1986. Different strategies in higher plants in mobilization and uptake of iron. *Journal of Plant Nutrition*. 9:695-713.
- Masson, J., N. Tremblay, and A. Grosselin. 1989. Influence of the pH and bicarbonate content on nutrient solutions on growth of celery seedlings cultivated in peat based media. *Acta Horticulturae*. 238:113-118.
- Matkin, O.A. and F. H. Petersen. 1971. Why and how to acidify irrigation water. *American Nurserymen*. 133:14, 73.
- Maxwell, C.A., C.P. Vance, G.H. Heichel, and S. Stade. 1984. CO<sub>2</sub> fixation in alfalfa and birdfoot trefoil root nodules and partitioning of <sup>14</sup>C to the plant. *Crop Science*. 24:257-264.
- McCallister, D.L., R.A. Wiese, and N.J. Soleman. 1989. Effect of potassium salts on alleviation of lime-induced chlorosis in soybean. *Journal of Plant Nutrition*. 12:1153-1174.
- McCray, J.M. and J.E. Matocha. 1992. Effects of soil water levels on solution bicarbonate, chlorosis and growth of sorghum. *Journal of Plant Nutrition*. 15:1877-1890.
- Mengel, K. 1994. Iron availability in plant tissue-Iron chlorosis on calcareous soils. *Plant and Soil*. 165:275-283.
- Mengel, K. and E.A. Kirkby. 2001. *Principles of plant nutrition*. 5<sup>th</sup> edition. Kluwer Academic Publishers, Dordrecht, The Netherlands.
- Mengel, K. and G. Geurtzen. 1986. Iron chlorosis on calcareous soils: alkaline nutritional condition as the cause for the chlorosis. *Journal of Plant Nutrition*. 9:161-173.
- Mengel, K., R. Plänker, and B. Hoffman. 1994. Relationship between leaf apoplast pH and iron chlorosis on sunflower (*Helianthus annuus* L.). *Journal of Plant Nutrition*. 17:1053-1065.

- Moog, P.R. and W. Brüggerman. 1995. Iron reductase systems on the plasma membrane: a review. p. 343-362. In: J. Abadía (ed.). Iron nutrition in soils and plants. Kluwer Academic Publishers, Boston, MA.
- Moran, R. 1982. Formulae for determination of chlorophyllous pigments extracted with N-N-dimethylformamide. *Plant Physiology*. 69:1376-1381.
- Mori, S. 1999. Iron acquisition by plants. *Current Opinion in Plant Biology*. 2:250-253.
- Nelson, P.V. 1998. Greenhouse operation and management. Prentice Hall, Upper Saddle River, NJ.
- Nikolic, M. and R. Kastori. 2000. Effect of bicarbonate and Fe supply on Fe nutrition of grapevine. *Journal of Plant Nutrition*. 23:1619-1627.
- Nikolic, M. and V. Römheld. 2002. Does high bicarbonate supply to roots change availability of iron in the leaf apoplast? *Plant and Soil*. 241: 67-74.
- Pearce, R.C., Y. Li, and L.P. Bush. 1999a. Calcium and bicarbonate effects on the growth and nutrient uptake of burley tobacco seedlings: hydroponic culture. *Journal of Plant Nutrition*. 22:1069-1078.
- Pearce, R.C., Y. Li, and L.P. Bush. 1999b. Calcium and bicarbonate effects on the growth and nutrient uptake of burley tobacco seedlings: float system. *Journal of Plant Nutrition*. 22:1079-1090.
- Peiter, E., F. Yan, and S. Schubert. 2001. Lime-induced growth depression in *Lupinus* species: are soil pH and bicarbonate involved? *Journal of Plant Nutrition and Soil Science*. 164:165-172.
- Petersen, F.H. 1996. Water testing and interpretation. p. 31-49. In: Reed, D.Wm. (Editor). Water, media and nutrition. Ball Publishing, Batavia, IL.
- Peterson, J.C. and L.L. Kramer, 1991. Water quality. p. 31-33. In: Tips on growing zonal geraniums. Ohio Florists' Association, Columbus, OH.
- Qi, J., J.D. Marshall, and K.G. Mattson. 1994. High soil carbon dioxide concentrations inhibit root respiration in Douglas fir. *New Phytologist*. 128:435-442.
- Rabotii, G. and G. Zocchi. 1994. Plasma membrane-bound H<sup>+</sup>-ATPase and reductase activities in Fe-deficient cucumber roots. *Physiologia Plantarum*. 90:779-785.
- Rayle, D.L. and R.E. Cleland. 1992. The acid growth theory of auxin-induced cell elongation is alive and well. *Plant Physiology*. 99:1271-1274.

- Reed, D.W. 1996a. Closed production systems for containerized crops: recirculating subirrigation and zero-leach systems. p. 221-245. In: D.W. Reed (ed). Water, media and nutrition for greenhouse crops. Ball Publishing, Batavia, IL.
- Reed, D.W. 1996b. Micronutrient nutrition. p. 171-195. In: D.W. Reed (ed). Water, media and nutrition for greenhouse crops. Ball Publishing, Batavia, IL.
- Rideout, J.W., D.T. Gooden, and S.B. Martin. 1995. Corrective measures for growing tobacco seedlings using the float system with water high in bicarbonate. Tobacco Science. 39:130-136.
- Romera, F.J., E. Alcántara, and M.D. de la Guardia. 1992. Effects of bicarbonate, phosphate and high pH on the reducing capacity of Fe-deficient sunflower and cucumber plants. Journal of Plant Nutrition. 15:1519-1530.
- Romera, F.J., E. Alcántara, and M.D. de la Guardia. 1997. Influence of bicarbonate and metal ions on the development of root Fe(III) reducing capacity by Fe-deficient cucumber (*Cucumis sativus*) plants. Physiologia Plantarum. 101:143-148.
- Römheld, V. 1997. The chlorosis paradox: Fe inactivation in leaves as a secondary event in Fe deficiency chlorosis. p. 10. In: 9<sup>th</sup> International Symposium on Iron Nutrition and Interactions in Plants. Hohenheim, Stuttgart, Germany.
- Römheld, V. 2000. The chlorosis paradox: Fe inactivation as a secondary event in chlorotic leaves of grapevine. Journal of Plant Nutrition. 23:1629-1643.
- Römheld, V. and H. Marshner. 1983. Mechanism of iron uptake by peanut plants. I. Fe<sup>III</sup> reduction, chelate splitting, and release of phenolics. Plant Physiology. 71:949-954.
- Römheld, V., H. Marshner, and D. Kramer. 1982. Responses to Fe deficiency in roots of "Fe-efficient" species. Journal of Plant Nutrition. 5:489-498.
- Rosenfield, C.-L., D.W. Reed, and M. Kent. 1991. Dependency of iron reduction on development of a unique root morphology in *Ficus benjamina* L. Plant Physiology. 95:1120-1124.
- Rutland, R.B. 1971. Radioisotopic evidence of immobilization of iron in azalea by excess calcium bicarbonate. Journal of the American Society for Horticultural Science. 96:653-655.

- Rutland, R.B. and M.J. Bukovac. 1971. The effect of calcium bicarbonate on iron absorption and distribution by *Chrysanthemum morifolium* (Ram.). *Plant and Soil*. 35:225-236.
- Schenk, M. and J. Wehrmann. 1979. The influence of ammonia in nutrient solution on growth and metabolism of cucumber plants. *Plant and Soil*. 52:403-414.
- Scheverns, E. and J. Cornell. 1993. Design and analysis of mixture systems: applications in hydroponic, plant nutrition research. *Plant and Soil*. 154:45-52.
- Schikora, A. and W. Schmidt. 2002. Formation of transfer cells and H<sup>+</sup>-ATPase expression in tomato roots under P and Fe deficiency. *Planta*. 215:304-311.
- Schmidt, W., J. Tittel, and A. Schikora. 2000. Role of hormones in the induction of iron deficiency responses in *Arabidopsis* roots. *Plant Physiology*. 122:1109-1118.
- Sibole, J.V., E. Montero, C. Cabot, C. Poschenrieder, and J. Barcelo. 2000. Relationship between carbon partitioning and Na<sup>+</sup> and Cl<sup>-</sup> and ABA allocation in fruits of salt-stressed bean. *Journal of Plant Physiology*. 157:637-642.
- Sijmons, P.C. and H.F. Bienfait. 1986. Development of Fe<sup>3+</sup> reduction activity and H<sup>+</sup> extrusion during growth of iron-deficient bean plants in a rhizostat. *Biochemie und Physiologie der Pflanzen*. 181:282-299.
- Tagliavini, M., A. Masia, and M. Quartieri. 1995. Bulk soil pH and rhizosphere pH of peach trees in calcareous and alkaline soils as affected by the form of nitrogen fertilizers. *Plant and Soil*. 176:263-271.
- Tagliavini, M., J. Abadía, A.D. Rombolà, A. Abadía, C. Tsipouridis, and B. Marangoni. 2000. Agronomic means for the control of iron deficiency chlorosis in deciduous fruit trees. *Journal of Plant Nutrition*. 23:2007-2022.
- Takkar, P.N., B. Ulrich, and K.J. Meiwes. 1987. Method for estimation of CO<sub>2</sub> (aq) plus H<sub>2</sub>CO<sub>3</sub>, HCO<sub>3</sub><sup>-</sup> and pH in soil solutions collected under field conditions. *Z. Pflanzenernähr.* 150:319-326.
- Tang, C. and A.D. Robson. 1993. pH above 6.0 reduces nodulation of *Lupinus* species. *Plant Soil*. 152:269-276.
- Tardieu, F., J. Zhang, and W.J. Davis. 1992. What information is conveyed by an ABA signal from maize roots in drying field soil? *Plant, Cell and Environment*. 15:185-191.

- Ternessi, M., A.P. Andrade, J. Jorrin, and M. Benlloch. 1994. Root-shoot signaling in sunflower plants with confined root systems. *Plant and Soil*. 166:31-36.
- Terry, N. and J. Abadía. 1986. Function of iron in chloroplasts. *Journal of Plant Nutrition*. 9:609-649.
- Tremblay, N., J. Masson, and A. Gosselin. 1989. Influence of pH and bicarbonate content of nutrient solutions on characteristics of saturated medium extract and mineral composition of celery seedlings. *Acta Horticulturae*. 2238:119-125.
- Vaast, P., R.J. Zasosky, and C.S. Bledsoe. 1998. Effects of solution pH, temperature, nitrate/ammonium ratios, and inhibitors of ammonium and nitrate uptake by arabica coffee in short-term solution culture. *Journal of Plant Nutrition*. 21:551-1564.
- Vapaavuori, E.M. and P. Pelkonen. 1985.  $\text{HCO}_3^-$  uptake through the roots and its effect on the productivity of willow cuttings. *Plant, Cell and Environment*. 8:531-534.
- Venkat Raju, K. and H. Marschner. 1981. Inhibition of iron stress reactions in sunflower by bicarbonate. *Zeitschrift fuer Pflanzenphysiologie*. 144:339-335.
- Vessey, J.K., L.T. Henry, S. Chaillou, and C.D. Raper. 1990. Root-zone acidity affects relative uptake of nitrate and ammonium from mixed nitrogen sources. *Journal of Plant Nutrition*. 13:95-116.
- Wadleigh, C.H. and J.W. Brown. 1952. The chemical status of bean plants afflicted with bicarbonate induced chlorosis. *Botanical Gazette*. 113:373-392.
- Wallace, A. and G.A. Wallace. 1986. Ornamental plants most likely to be killed by iron deficiency and some control measures. *Journal of Plant Nutrition*. 9:1009-1014.
- Wei, L., R.H. Loeppert, and W.R. Ocumpaugh. 1998. Analysis of iron-deficiency induced hydrogen release by plant roots using chemical equilibrium and pH-stat methods. *Journal of Plant Nutrition*. 21:1539-1549.
- Whipker, B.E. 2001. Alkalinity control. p.9-12. In: B.E. Whipker, J.M. Dole, T.J. Cavins, J.L. Gibson, W.C. Fonteno, P.V. Nelson, D.S. Pitchay, and D.A. Bailey. *Plant root zone management*. North Carolina Flower Growers Association, Raleigh, NC.
- Whipker, B.E., D.A. Bailey, P.V. Nelson, W.C. Fonteno, and P.A. Hammer. 1996. A novel approach to calculate acid additions for alkalinity control in greenhouse irrigation water. *Communications Soil Science and Plant Analysis*. 27:959-976.

- Yan, F., S. Shubert, and K. Mengel. 1992. Effect of low root medium pH on net proton release, root respiration, and root growth of corn (*Zea mays* L.) and broad bean (*Vicia faba* L.). *Plant Physiology*. 99:415-421.
- Yang, X., V. Römheld, and H. Marschner. 1993. Effect of bicarbonate and root zone temperature on uptake of Zn, Fe, Mn and Cu by different rice cultivars (*Oryza sativa* L.) grown in calcareous soil. *Plant and Soil*. 155/156:441-444.
- Yang, X., V. Römheld, and H. Marschner. 1994. Effect of bicarbonate on root growth and accumulation of organic acids in Zn-inefficient and Zn-efficient rice cultivars (*Oryza sativa* L.). *Plant and Soil*. 164:1-7.
- Yu, Q., C. Tang, and J. Kuo. 2000. A critical review on methods to measure apoplastic pH in plants. *Plant and Soil*. 219:29-40.
- Zaharieva, T. and V. Römheld. 2000. Specific Fe<sup>2+</sup> uptake system in strategy I plants inducible under Fe deficiency. *Journal of Plant Nutrition*. 23:1733-1744.
- Zäid, E.H., M. Arahou, H.G. Diem, and R.E. Morabet. 2003. Is Fe deficiency rather than P deficiency the cause of cluster root formation in *Casuarina* species? *Plant and Soil*. 248:229-235.
- Zhou, H.J., R.F. Korcak, F. Fan, and M. Faust. 1984. The effect of bicarbonate induced Fe chlorosis on mineral content and Ca<sup>45</sup> uptake of apple seedlings. *Journal of Plant Nutrition*. 7:1355-1364.
- Zouari, M., A. Abadía, and J. Abadía. 2001. Iron is required for the induction of root ferric chelate reductase activity in iron-deficient tomato. *Journal of Plant Nutrition*. 24:383-396.
- Zribi, K. and M. Gharsalli. 2002. Effect of bicarbonate on growth and iron nutrition of pea. *Journal of Plant Nutrition*. 25:2143-2149.

## APPENDIX

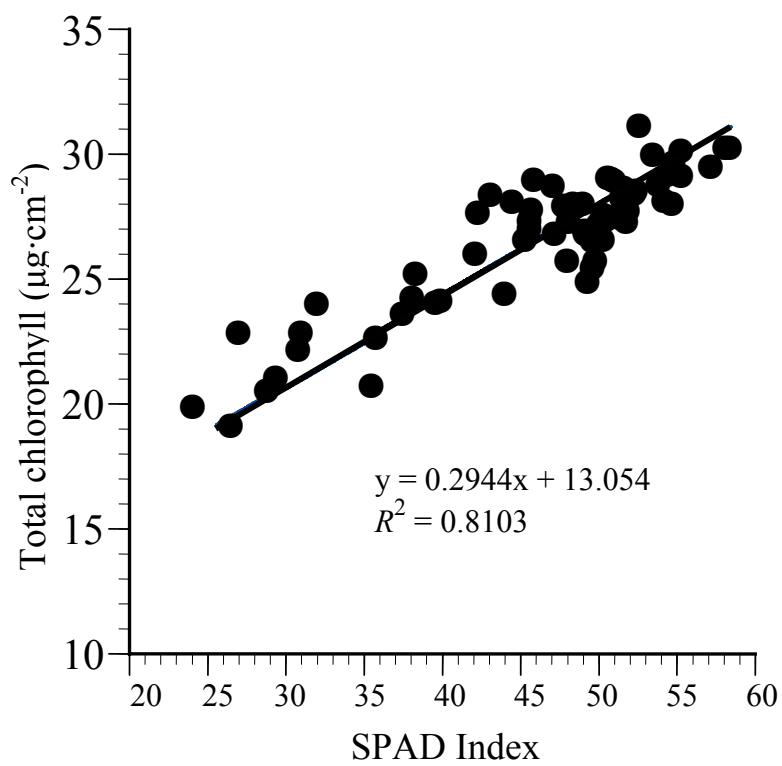

Fig. A1. Regression analysis for the relationship between the SPAD index and total chlorophyll concentration on bean leaves (*Phaseolus vulgaris* L.) 'Poncho'.



Table A1. Complete modified Hoagland's nutrient solution used to grow hibiscus cv 'Bimini Breeze' and 'Carolina Breeze' in Experiment 4.2.

Source	mg·L <sup>-1</sup>	mg·L <sup>-1</sup>												
		N	P	K	Ca	Mg	S	Fe	Cu	Zn	Mo	Mn	B	
Ca(NO <sub>3</sub> ) <sub>2</sub> ·4H <sub>2</sub> O	826.00	98.0			140.2									
(NH <sub>4</sub> ) <sub>2</sub> SO <sub>4</sub>	198.00	42.0					48.0							
KNO <sub>3</sub>	506.00	70.4		195.7										
CaSO <sub>4</sub> ·2H <sub>2</sub> O	174.00				40.5		32.4							
KH <sub>2</sub> PO <sub>4</sub>	136.00		31.0	39.1										
MgSO <sub>4</sub> ·7H <sub>2</sub> O	493.00					48.6	64.1							
Fe-DTPA	50.00							5.0						
CuSO <sub>4</sub> ·5H <sub>2</sub> O	0.08						0.01		0.02					
ZnSO <sub>4</sub> ·5H <sub>2</sub> O	0.22						0.02			0.05				
(NH <sub>4</sub> ) <sub>6</sub> Mo <sub>7</sub> O <sub>24</sub> ·4H <sub>2</sub> O	0.20	0.01									0.11			
H <sub>3</sub> BO <sub>3</sub>	2.86													0.50
MnSO <sub>4</sub> ·H <sub>2</sub> O	1.81						0.38						0.65	
TOTAL ( mg·L <sup>-1</sup> )		210.4	31.0	234.8	180.7	48.6	144.9	5.0	0.02	0.05	0.11	0.65	0.50	
TOTAL (mM)		15.0	1.0	6.0	4.5	2.0	4.5							

Table A2. Complete 25% strength modified Hoagland's nutrient solution (100% strength for micronutrients) with a 1 NO<sub>3</sub><sup>-</sup> : 0 NH<sub>4</sub><sup>+</sup> ratio.

Source	mg·L <sup>-1</sup>	mg·L <sup>-1</sup>												
		N	P	K	Ca	Mg	S	Fe	Cu	Zn	Mo	Mn	B	Na
Ca(NO <sub>3</sub> ) <sub>2</sub> ·4H <sub>2</sub> O	266.08	31.60			45.2									
(NH <sub>4</sub> ) <sub>2</sub> SO <sub>4</sub>														
NaNO <sub>3</sub>	20.63	3.40												0.9
KNO <sub>3</sub>	126.43	17.60		48.9										
K <sub>2</sub> SO <sub>4</sub>														
CaSO <sub>4</sub> ·2H <sub>2</sub> O														
KH <sub>2</sub> PO <sub>4</sub>	34.03		7.75	9.8										
MgSO <sub>4</sub> ·7H <sub>2</sub> O	123.23					12.3	16.03							
Fe-DTPA	50.00							5.0						
CuSO <sub>4</sub> ·5H <sub>2</sub> O	0.08						0.01		0.02					
ZnSO <sub>4</sub> ·5H <sub>2</sub> O	0.22						0.02			0.05				
(NH <sub>4</sub> ) <sub>6</sub> Mo <sub>7</sub> O <sub>24</sub> ·4H <sub>2</sub> O	0.20	0.01									0.11			
H <sub>3</sub> BO <sub>3</sub>	2.86													0.50
MnSO <sub>4</sub> ·H <sub>2</sub> O	1.81						0.38						0.65	
TOTAL ( mg·L <sup>-1</sup> )		52.60	7.75	58.7	45.2	12.3	16.44	5.0	0.02	0.05	0.11	0.65	0.50	0.9
TOTAL (mM)		3.75	0.25	1.5	1.13	0.5	0.51							

Table A3. Complete 100% strength modified Hoagland's nutrient solution with a 1 NO<sub>3</sub><sup>-</sup> : 0 NH<sub>4</sub><sup>+</sup> ratio<sup>z</sup>.

Source	mg·L <sup>-1</sup>	mg·L <sup>-1</sup>													
		N	P	K	Ca	Mg	S	Fe	Cu	Zn	Mo	Mn	B	Na	
Ca(NO <sub>3</sub> ) <sub>2</sub> ·4H <sub>2</sub> O	1064.30	126.2			180.6										
(NH <sub>4</sub> ) <sub>2</sub> SO <sub>4</sub>															
NaNO <sub>3</sub>	82.50	13.6													3.7
KNO <sub>3</sub>	505.70	70.3		195.6											
K <sub>2</sub> SO <sub>4</sub>															
CaSO <sub>4</sub> ·2H <sub>2</sub> O															
KH <sub>2</sub> PO <sub>4</sub>	136.10		31.0	39.1											
MgSO <sub>4</sub> ·7H <sub>2</sub> O	492.90					48.8	64.10								
Fe-DTPA	50.00							5.0							
CuSO <sub>4</sub> ·5H <sub>2</sub> O	0.08						0.01		0.02						
ZnSO <sub>4</sub> ·5H <sub>2</sub> O	0.22						0.02			0.05					
(NH <sub>4</sub> ) <sub>6</sub> Mo <sub>7</sub> O <sub>24</sub> ·4H <sub>2</sub> O	0.20	0.01									0.11				
H <sub>3</sub> BO <sub>3</sub>	2.86													0.50	
MnSO <sub>4</sub> ·H <sub>2</sub> O	1.81						0.38					0.65			
TOTAL ( mg·L <sup>-1</sup> )		210.2	31.0	234.7	180.6	48.8	64.51	5.0	0.02	0.05	0.11	0.65	0.50	3.7	
TOTAL (mM)		15.0	1.0	6.0	4.5	2.0	2.00								

<sup>z</sup>For the 5 mM NaHCO<sub>3</sub> solutions, 420 mg·L<sup>-1</sup> of NaHCO<sub>3</sub> were added to the solutions, yielding 114.9 mg·L<sup>-1</sup> of Na<sup>+</sup>

Table A4. Complete 25% strength modified Hoagland's nutrient solution (100% strength for micronutrients) with a 0.75 NO<sub>3</sub><sup>-</sup> : 0.25 NH<sub>4</sub><sup>+</sup> ratio.

Source	mg·L <sup>-1</sup>	mg·L <sup>-1</sup>													
		N	P	K	Ca	Mg	S	Fe	Cu	Zn	Mo	Mn	B	Na	
Ca(NO <sub>3</sub> ) <sub>2</sub> ·4H <sub>2</sub> O	184.28	21.9			31.4										
(NH <sub>4</sub> ) <sub>2</sub> SO <sub>4</sub>	61.78	13.1					14.98								
NaNO <sub>3</sub>															
KNO <sub>3</sub>	126.43	17.6		48.9											
K <sub>2</sub> SO <sub>4</sub>															
CaSO <sub>4</sub> ·2H <sub>2</sub> O	59.58				14.9		5.55								
KH <sub>2</sub> PO <sub>4</sub>	34.03		7.75	9.8											
MgSO <sub>4</sub> ·7H <sub>2</sub> O	123.23					12.3	16.03								
Fe-DTPA	50.00							5.0							
CuSO <sub>4</sub> ·5H <sub>2</sub> O	0.08						0.01		0.02						
ZnSO <sub>4</sub> ·5H <sub>2</sub> O	0.22						0.02			0.05					
(NH <sub>4</sub> ) <sub>6</sub> Mo <sub>7</sub> O <sub>24</sub> ·4H <sub>2</sub> O	0.20	0.01									0.11				
H <sub>3</sub> BO <sub>3</sub>	2.86													0.50	
MnSO <sub>4</sub> ·H <sub>2</sub> O	1.81						0.38						0.65		
TOTAL ( mg·L <sup>-1</sup> )		52.60	7.75	58.7	46.3	12.3	37.0	5.0	0.02	0.05	0.11	0.65	0.50	0	
TOTAL (mM)		3.75	0.25	1.5	1.2	0.5	1.14								

Table A5. Complete 100% strength modified Hoagland's nutrient solution with a 0.75 NO<sub>3</sub><sup>-</sup> : 0.25 NH<sub>4</sub><sup>+</sup> ratio<sup>z</sup>.

Source	mg·L <sup>-1</sup>	mg·L <sup>-1</sup>													
		N	P	K	Ca	Mg	S	Fe	Cu	Zn	Mo	Mn	B	Na	
Ca(NO <sub>3</sub> ) <sub>2</sub> ·4H <sub>2</sub> O	737.10	87.4			125.1										
(NH <sub>4</sub> ) <sub>2</sub> SO <sub>4</sub>	247.10	52.4					59.90								
NaNO <sub>3</sub>															
KNO <sub>3</sub>	505.70	70.3		195.6											
K <sub>2</sub> SO <sub>4</sub>															
CaSO <sub>4</sub> ·2H <sub>2</sub> O	238.32				59.5		22.20								
KH <sub>2</sub> PO <sub>4</sub>	136.10		31.0	39.1											
MgSO <sub>4</sub> ·7H <sub>2</sub> O	492.90					48.8	64.10								
Fe-DTPA	50.00							5.0							
CuSO <sub>4</sub> ·5H <sub>2</sub> O	0.08						0.01		0.02						
ZnSO <sub>4</sub> ·5H <sub>2</sub> O	0.22						0.02			0.05					
(NH <sub>4</sub> ) <sub>6</sub> Mo <sub>7</sub> O <sub>24</sub> ·4H <sub>2</sub> O	0.20	0.01									0.11				
H <sub>3</sub> BO <sub>3</sub>	2.86													0.50	
MnSO <sub>4</sub> ·H <sub>2</sub> O	1.81						0.38						0.65		
TOTAL ( mg·L <sup>-1</sup> )		210.1	31.0	234.7	184.6	48.8	146.61	5.0	0.02	0.05	0.11	0.65	0.50	0	
TOTAL (mM)		15.0	1.0	6.0	4.6	2.0	4.56								

<sup>z</sup>For the 5 mM NaHCO<sub>3</sub> solutions, 420 mg·L<sup>-1</sup> of NaHCO<sub>3</sub> was added to the solutions, yielding 114.9 mg·L<sup>-1</sup> of Na<sup>+</sup>

Table A6. Complete 25% strength modified Hoagland's nutrient solution (100% strength for micronutrients) with a 0.5 NO<sub>3</sub><sup>-</sup> : 0.5 NH<sub>4</sub><sup>+</sup> ratio.

Source	mg·L <sup>-1</sup>	mg·L <sup>-1</sup>												
		N	P	K	Ca	Mg	S	Fe	Cu	Zn	Mo	Mn	B	Na
Ca(NO <sub>3</sub> ) <sub>2</sub> ·4H <sub>2</sub> O	94.65	11.23			16.1									
(NH <sub>4</sub> ) <sub>2</sub> SO <sub>4</sub>	123.75	26.23					30.03							
NaNO <sub>3</sub>														
KNO <sub>3</sub>	108.40	15.08		41.9										
K <sub>2</sub> SO <sub>4</sub>	15.50			7.0			2.85							
CaSO <sub>4</sub> ·2H <sub>2</sub> O	125.00				29.1		23.3							
KH <sub>2</sub> PO <sub>4</sub>	34.03		7.75	9.8										
MgSO <sub>4</sub> ·7H <sub>2</sub> O	123.23					12.3	16.03							
Fe-DTPA	50.00							5.0						
CuSO <sub>4</sub> ·5H <sub>2</sub> O	0.08						0.01		0.02					
ZnSO <sub>4</sub> ·5H <sub>2</sub> O	0.22						0.02			0.05				
(NH <sub>4</sub> ) <sub>6</sub> Mo <sub>7</sub> O <sub>24</sub> ·4H <sub>2</sub> O	0.20	0.01									0.11			
H <sub>3</sub> BO <sub>3</sub>	2.86													0.50
MnSO <sub>4</sub> ·H <sub>2</sub> O	1.81						0.38						0.65	
TOTAL ( mg·L <sup>-1</sup> )		52.50	7.75	58.7	45.2	12.3	72.62	5.0	0.02	0.05	0.11	0.65	0.50	0
TOTAL (mM)		3.75	0.25	1.5	1.13	0.5	2.25							

Table A7. Complete 100% strength modified Hoagland's nutrient solution with a 0.5 NO<sub>3</sub><sup>-</sup> : 0.5 NH<sub>4</sub><sup>+</sup> ratio<sup>z</sup>.

Source	mg·L <sup>-1</sup>	mg·L <sup>-1</sup>													
		N	P	K	Ca	Mg	S	Fe	Cu	Zn	Mo	Mn	B	Na	
Ca(NO <sub>3</sub> ) <sub>2</sub> ·4H <sub>2</sub> O	378.60	44.90			64.2										
(NH <sub>4</sub> ) <sub>2</sub> SO <sub>4</sub>	495.00	104.90					120.10								
NaNO <sub>3</sub>															
KNO <sub>3</sub>	433.60	60.3		167.7											
K <sub>2</sub> SO <sub>4</sub>	62.00			27.8			11.40								
CaSO <sub>4</sub> ·2H <sub>2</sub> O	500.0				116.4		93.1								
KH <sub>2</sub> PO <sub>4</sub>	136.10		31.0	39.1											
MgSO <sub>4</sub> ·7H <sub>2</sub> O	492.90					48.8	64.10								
Fe-DTPA	50.00							5.0							
CuSO <sub>4</sub> ·5H <sub>2</sub> O	0.08						0.01		0.02						
ZnSO <sub>4</sub> ·5H <sub>2</sub> O	0.22						0.02			0.05					
(NH <sub>4</sub> ) <sub>6</sub> Mo <sub>7</sub> O <sub>24</sub> ·4H <sub>2</sub> O	0.20	0.01									0.11				
H <sub>3</sub> BO <sub>3</sub>	2.86													0.50	
MnSO <sub>4</sub> ·H <sub>2</sub> O	1.81						0.38						0.65		
TOTAL ( mg·L <sup>-1</sup> )		210.1	31.0	234.6	180.6	48.8	289.11	5.0	0.02	0.05	0.11	0.65	0.50	0	
TOTAL (mM)		15.0	1.0	6.0	4.5	2.0	9.00								

<sup>z</sup>For the 5 mM NaHCO<sub>3</sub> solutions, 420 mg·L<sup>-1</sup> of NaHCO<sub>3</sub> was added to the solutions, yielding 114.9 mg·L<sup>-1</sup> of Na<sup>+</sup>

Table A8. Complete 25% strength modified Hoagland's nutrient solution (100% strength for micronutrients) with a 0.25 NO<sub>3</sub><sup>-</sup> : 0.75 NH<sub>4</sub><sup>+</sup> ratio.

Source	mg·L <sup>-1</sup>	mg·L <sup>-1</sup>													
		N	P	K	Ca	Mg	S	Fe	Cu	Zn	Mo	Mn	B	Na	
Ca(NO <sub>3</sub> ) <sub>2</sub> ·4H <sub>2</sub> O	110.35	13.10			18.7										
(NH <sub>4</sub> ) <sub>2</sub> SO <sub>4</sub>	185.90	39.40					45.10								
NaNO <sub>3</sub>															3.7
KNO <sub>3</sub>															
K <sub>2</sub> SO <sub>4</sub>	108.90			48.9			20.05								
CaSO <sub>4</sub> ·2H <sub>2</sub> O	113.45				26.43		21.13								
KH <sub>2</sub> PO <sub>4</sub>	34.03		7.75	9.8											
MgSO <sub>4</sub> ·7H <sub>2</sub> O	123.23					12.3	16.03								
Fe-DTPA	50.00							5.0							
CuSO <sub>4</sub> ·5H <sub>2</sub> O	0.08						0.01		0.02						
ZnSO <sub>4</sub> ·5H <sub>2</sub> O	0.22						0.02			0.05					
(NH <sub>4</sub> ) <sub>6</sub> Mo <sub>7</sub> O <sub>24</sub> ·4H <sub>2</sub> O	0.20	0.01									0.11				
H <sub>3</sub> BO <sub>3</sub>	2.86														0.50
MnSO <sub>4</sub> ·H <sub>2</sub> O	1.81						0.38						0.65		
TOTAL ( mg·L <sup>-1</sup> )		52.50	7.75	58.7	45.1	12.3	86.69	5.0	0.02	0.05	0.11	0.65	0.50	3.7	
TOTAL (mM)		3.75	0.25	1.5	1.13	0.5	2.70								



Table A9. Complete 100% strength modified Hoagland's nutrient solution with a 0.25 NO<sub>3</sub><sup>-</sup> : 0.75 NH<sub>4</sub><sup>+</sup> ratio<sup>2</sup>.

Source	mg·L <sup>-1</sup>	mg·L <sup>-1</sup>												
		N	P	K	Ca	Mg	S	Fe	Cu	Zn	Mo	Mn	B	Na
Ca(NO <sub>3</sub> ) <sub>2</sub> ·4H <sub>2</sub> O	441.40	52.40			74.9									
(NH <sub>4</sub> ) <sub>2</sub> SO <sub>4</sub>	743.6	157.60					180.40							
NaNO <sub>3</sub>														3.7
KNO <sub>3</sub>														
K <sub>2</sub> SO <sub>4</sub>	435.60			195.6			80.20							
CaSO <sub>4</sub> ·2H <sub>2</sub> O	453.80				105.7		84.50							
KH <sub>2</sub> PO <sub>4</sub>	136.10		31.0	39.1										
MgSO <sub>4</sub> ·7H <sub>2</sub> O	492.90					48.8	64.10							
Fe-DTPA	50.00							5.0						
CuSO <sub>4</sub> ·5H <sub>2</sub> O	0.08						0.01		0.02					
ZnSO <sub>4</sub> ·5H <sub>2</sub> O	0.22						0.02			0.05				
(NH <sub>4</sub> ) <sub>6</sub> Mo <sub>7</sub> O <sub>24</sub> ·4H <sub>2</sub> O	0.20	0.01									0.11			
H <sub>3</sub> BO <sub>3</sub>	2.86													0.50
MnSO <sub>4</sub> ·H <sub>2</sub> O	1.81						0.38					0.65		
TOTAL ( mg·L <sup>-1</sup> )		210.0	31.0	234.7	180.6	48.8	409.61	5.0	0.02	0.05	0.11	0.65	0.50	3.7
TOTAL (mM)		15.0	1.0	6.0	4.5	2.0	12.76							

<sup>2</sup>For the 5 mM NaHCO<sub>3</sub> solutions, 420 mg·L<sup>-1</sup> of NaHCO<sub>3</sub> was added to the solutions, yielding 114.9 mg·L<sup>-1</sup> of Na<sup>+</sup>

Table A10. Complete 25% strength modified Hoagland's nutrient solution (100% strength for micronutrients) with a 0 NO<sub>3</sub><sup>-</sup> : 1 NH<sub>4</sub><sup>+</sup> ratio.

Source	mg·L <sup>-1</sup>	mg·L <sup>-1</sup>												
		N	P	K	Ca	Mg	S	Fe	Cu	Zn	Mo	Mn	B	Na
Ca(NO <sub>3</sub> ) <sub>2</sub> ·4H <sub>2</sub> O														
(NH <sub>4</sub> ) <sub>2</sub> SO <sub>4</sub>	247.68	52.50					60.08							
NaNO <sub>3</sub>														
KNO <sub>3</sub>														
K <sub>2</sub> SO <sub>4</sub>	108.90			48.9			20.05							
CaSO <sub>4</sub> ·2H <sub>2</sub> O	193.93				45.2		36.10							
KH <sub>2</sub> PO <sub>4</sub>	34.03		7.75	9.8										
MgSO <sub>4</sub> ·7H <sub>2</sub> O	123.23					12.3	16.03							
Fe-DTPA	50.00							5.0						
CuSO <sub>4</sub> ·5H <sub>2</sub> O	0.08						0.01		0.02					
ZnSO <sub>4</sub> ·5H <sub>2</sub> O	0.22						0.02			0.05				
(NH <sub>4</sub> ) <sub>6</sub> Mo <sub>7</sub> O <sub>24</sub> ·4H <sub>2</sub> O	0.20	0.01									0.11			
H <sub>3</sub> BO <sub>3</sub>	2.86													0.50
MnSO <sub>4</sub> ·H <sub>2</sub> O	1.81						0.38						0.65	
TOTAL ( mg·L <sup>-1</sup> )		52.50	7.75	58.7	45.2	12.3	132.67	5.0	0.02	0.05	0.11	0.65	0.50	0
TOTAL (mM)		3.75	0.25	1.5	1.13	0.5	4.13							

Table A11 Complete 100% strength modified Hoagland's nutrient solution with a 0 NO<sub>3</sub><sup>-</sup> : 1 NH<sub>4</sub><sup>+</sup> ratio<sup>z</sup>.

Source	mg·L <sup>-1</sup>	mg·L <sup>-1</sup>													
		N	P	K	Ca	Mg	S	Fe	Cu	Zn	Mo	Mn	B	Na	
Ca(NO <sub>3</sub> ) <sub>2</sub> ·4H <sub>2</sub> O															
(NH <sub>4</sub> ) <sub>2</sub> SO <sub>4</sub>	990.70	210.0					240.3								
NaNO <sub>3</sub>															
KNO <sub>3</sub>															
K <sub>2</sub> SO <sub>4</sub>	435.60			195.6			80.2								
CaSO <sub>4</sub> ·2H <sub>2</sub> O	775.73				180.6		144.4								
KH <sub>2</sub> PO <sub>4</sub>	136.10		31.0	39.1											
MgSO <sub>4</sub> ·7H <sub>2</sub> O	492.90					48.8	64.10								
Fe-DTPA	50.00							5.0							
CuSO <sub>4</sub> ·5H <sub>2</sub> O	0.08						0.01		0.02						
ZnSO <sub>4</sub> ·5H <sub>2</sub> O	0.22						0.02			0.05					
(NH <sub>4</sub> ) <sub>6</sub> Mo <sub>7</sub> O <sub>24</sub> ·4H <sub>2</sub> O	0.20	0.01									0.11				
H <sub>3</sub> BO <sub>3</sub>	2.86													0.50	
MnSO <sub>4</sub> ·H <sub>2</sub> O	1.81						0.38						0.65		
TOTAL (mg·L <sup>-1</sup> )		210.0	31.0	234.7	180.6	48.8	529.41	5.0	0.02	0.05	0.11	0.65	0.50	0	
TOTAL (mM)		15.0	1.0	6.0	4.5	2.0	16.50								

<sup>z</sup>For the 5 mM NaHCO<sub>3</sub> solutions, 420 mg·L<sup>-1</sup> of NaHCO<sub>3</sub> was added, yielding 114.9 mg·L<sup>-1</sup> of Na<sup>+</sup>

Table A12. Complete 25% strength modified Hoagland's nutrient solution for establishing bean plants.

Source	mg·L <sup>-1</sup>												
	mg·L <sup>-1</sup>	N	P	K	Ca	Mg	S	Fe	Cu	Zn	Mo	B	Mn
Ca(NO <sub>3</sub> ) <sub>2</sub> ·4H <sub>2</sub> O	184.29	21.86			31.27								
(NH <sub>4</sub> ) <sub>2</sub> SO <sub>4</sub>	61.79	13.10					14.99						
KNO <sub>3</sub>	126.43	17.59		48.9									
CaSO <sub>4</sub> ·2H <sub>2</sub> O	59.58				13.87		11.09						
KH <sub>2</sub> PO <sub>4</sub>	34.03		7.75	9.8									
MgSO <sub>4</sub> ·7H <sub>2</sub> O	123.21					12.2	16.03						
Fe-DTPA	12.50							1.25					
CuSO <sub>4</sub> ·5H <sub>2</sub> O	0.02						0.003		0.005				
ZnSO <sub>4</sub> ·5H <sub>2</sub> O	0.06						0.005			0.013			
(NH <sub>4</sub> ) <sub>6</sub> Mo <sub>7</sub> O <sub>24</sub> ·4H <sub>2</sub> O	0.05	0.003									0.027		
H <sub>3</sub> BO <sub>3</sub>	0.72											0.125	
MnSO <sub>4</sub> ·H <sub>2</sub> O	0.50												0.125
TOTAL ( mg·L <sup>-1</sup> )		52.55	7.75	58.7	45.14	12.2	42.12	1.25	0.005	0.013	0.027	0.125	0.125
TOTAL (mM)		3.75	0.25	1.5	1.13	0.5	1.31						

Table A13. Nutrient solutions for the  $\text{NH}_4^+:\text{K}^+:\text{Na}^+$  mixtures used in Experiment 6.1.

Source	Mixtures									
	Concentration $\text{mg}\cdot\text{L}^{-1}$									
	1:0:0	$\frac{1}{2}:\frac{1}{2}:0$	0:1:0	$0:\frac{1}{2}:\frac{1}{2}$	0:1:0	$\frac{1}{2}:0:\frac{1}{2}$	$\frac{1}{3}:\frac{1}{3}:\frac{1}{3}$	$\frac{2}{3}:\frac{1}{6}:\frac{1}{6}$	$\frac{1}{6}:\frac{2}{3}:\frac{1}{6}$	$\frac{1}{6}:\frac{1}{6}:\frac{2}{3}$
$\text{NH}_4\text{HCO}_3$	396.2	198.1				198.1	132.6	264.1	65.7	65.7
$\text{NaHCO}_3$				210.1	420.2	210.1	140.3	69.8	69.8	279.9
$\text{KHCO}_3$		249.7	500.5	249.7			165.5	83.0	334.2	83.8
$\text{Ca}(\text{NO}_3)_2\cdot 4\text{H}_2\text{O}$	590.2	851.5	851.5	851.5	851.5	851.5	851.5	787.5	851.5	851.5
$\text{CaSO}_4\cdot 2\text{H}_2\text{O}$	190.3							46.8		
$\text{Mg}(\text{NO}_3)_2$		37.5	358.6	358.6	358.6	37.6	144.6		251.6	251.6
$\text{MgSO}_4\cdot 7\text{H}_2\text{O}$	394.5	358.0	48.7	48.7	48.7	357.0	255.6	394.5	152.1	152.1
Fe-DTPA	2.50	2.50	2.50	2.50	2.50	2.50	2.50	2.50	2.50	2.50
$\text{CuSO}_4\cdot 5\text{H}_2\text{O}$	0.01	0.01	0.01	0.01	0.01	0.01	0.01	0.01	0.01	0.01
$\text{ZnSO}_4\cdot 5\text{H}_2\text{O}$	0.025	0.025	0.025	0.025	0.025	0.025	0.025	0.025	0.025	0.025
$(\text{NH}_4)_6\text{Mo}_7\text{O}_{24}\cdot 4\text{H}_2\text{O}$	0.14	0.14	0.14	0.14	0.14	0.14	0.14	0.14	0.14	0.14
$\text{H}_3\text{BO}_3$	0.33	0.33	0.33	0.33	0.33	0.33	0.33	0.33	0.33	0.33
$\text{MnSO}_4\cdot \text{H}_2\text{O}$	0.25	0.25	0.25	0.25	0.25	0.25	0.25	0.25	0.25	0.25

Table A14. Nutrient solutions and Cs<sup>+</sup>:K<sup>+</sup>:Na<sup>+</sup> mixtures used in Experiment 6.2<sup>z</sup>.

Source	Mixtures									
	Concentration mg·L <sup>-1</sup>									
	1:0:0	1/2:1/2:0	0:1:0	0:1/2:1/2	0:1:0	1/2:0:1/2	1/3:1/3:1/3	2/3:1/6:1/6	1/6:2/3:1/6	1/6:1/6:2/3
0 mM HCO <sub>3</sub> <sup>-</sup>										
Cs <sub>2</sub> SO <sub>4</sub>	904.7	452.4				452.4	302.2	604.4	150.2	150.2
Na <sub>2</sub> SO <sub>4</sub>				177.6	355.1	177.6	118.6	58.9	58.9	237.2
K <sub>2</sub> SO <sub>4</sub>		217.6	435.1	217.6			143.6	72.2	290.7	72.2
Ca(NO <sub>3</sub> ) <sub>2</sub> ·4H <sub>2</sub> O	1064.2	1064.2	1064.2	1064.2	1064.2	1064.2	1064.2	1064.2	1064.2	1064.2
NH <sub>4</sub> NO <sub>3</sub>	120.0	120.0	120.0	120.0	120.0	120.0	120.0	120.0	120.0	120.0
Mg(NO <sub>4</sub> ) <sub>2</sub>	382.4	382.4	382.4	382.4	382.4	382.4	382.4	382.4	382.4	382.4
MgSO <sub>4</sub> ·7H <sub>2</sub> O	126.8	126.8	126.8	126.8	126.8	126.8	126.8	126.8	126.8	126.8
5 mM HCO <sub>3</sub> <sup>-</sup>										
CsHCO <sub>3</sub>	969.5	484.8				484.8	323.8	647.7	161.0	161.0
NaHCO <sub>3</sub>				210.0	420.0	210.0	140.3	69.7	69.7	280.6
KHCO <sub>3</sub>		250.4	500.6	250.3			165.2	83.1	334.4	83.1
Ca(NO <sub>3</sub> ) <sub>2</sub> ·4H <sub>2</sub> O	1064.2	1064.2	1064.2	1064.2	1064.2	1064.2	1064.2	1064.2	1064.2	1064.2
NH <sub>4</sub> NO <sub>3</sub>	120.0	120.0	120.0	120.0	120.0	120.0	120.0	120.0	120.0	120.0
Mg(NO <sub>4</sub> ) <sub>2</sub>	382.4	382.4	382.4	382.4	382.4	382.4	382.4	382.4	382.4	382.4
MgSO <sub>4</sub> ·7H <sub>2</sub> O	126.8	126.8	126.8	126.8	126.8	126.8	126.8	126.8	126.8	126.8
CaSO <sub>4</sub>	272.3	272.3	272.3	272.3	272.3	272.3	272.3	272.3	272.3	272.3

<sup>z</sup>All solutions contained Fe-DTPA, CuSO<sub>4</sub>·5H<sub>2</sub>O, (NH<sub>4</sub>)<sub>6</sub>Mo<sub>7</sub>O<sub>24</sub>·4H<sub>2</sub>O, H<sub>3</sub>BO<sub>3</sub>, MnCl<sub>2</sub>·4H<sub>2</sub>O as indicated in Table A15

Table A15. Complete 50% strength modified Hoagland's nutrient solution (100% micronutrients) used for plants establishing in Experiment 6.3.

Source	mg·L <sup>-1</sup>	mg·L <sup>-1</sup>												
		N	P	K	Ca	Mg	S	Fe	Cu	Zn	Mo	Mn	B	
Ca(NO <sub>3</sub> ) <sub>2</sub> ·4H <sub>2</sub> O	532.2	63.1			90.3									
(NH <sub>4</sub> ) <sub>2</sub> SO <sub>4</sub>	49.6	10.5					12.0							
KNO <sub>3</sub>	226.6	31.5		87.6										
KH <sub>2</sub> PO <sub>4</sub>	68.2		15.5	19.6										
MgSO <sub>4</sub> ·7H <sub>2</sub> O	246.5					24.3	32.0							
Fe-DTPA	50.00							5.0						
CuSO <sub>4</sub> ·5H <sub>2</sub> O	0.08						0.01		0.02					
ZnSO <sub>4</sub> ·5H <sub>2</sub> O	0.22						0.02			0.05				
(NH <sub>4</sub> ) <sub>6</sub> Mo <sub>7</sub> O <sub>24</sub> ·4H <sub>2</sub> O	0.20	0.01									0.11			
H <sub>3</sub> BO <sub>3</sub>	2.86													0.50
MnSO <sub>4</sub> ·H <sub>2</sub> O	1.81						0.38						0.65	
TOTAL (mg·L <sup>-1</sup> )		105.1	15.5	107.2	90.3	24.3	44.41	5.0	0.02	0.05	0.11	0.65	0.50	
TOTAL (mM)		7.5	0.5	2.74	2.25	1.0	1.38							

Table A16. Nutrient solutions and Rb<sup>+</sup>:K<sup>+</sup>:Na<sup>+</sup> mixtures used in Experiment 6.3<sup>z</sup>.

Source	Mixtures									
	Concentration mg·L <sup>-1</sup>									
	1:0:0	<sup>1</sup> / <sub>2</sub> : <sup>1</sup> / <sub>2</sub> :0	0:1:0	0: <sup>1</sup> / <sub>2</sub> : <sup>1</sup> / <sub>2</sub>	0:1:0	<sup>1</sup> / <sub>2</sub> :0: <sup>1</sup> / <sub>2</sub>	<sup>1</sup> / <sub>3</sub> : <sup>1</sup> / <sub>3</sub> : <sup>1</sup> / <sub>3</sub>	<sup>2</sup> / <sub>3</sub> : <sup>1</sup> / <sub>6</sub> : <sup>1</sup> / <sub>6</sub>	<sup>1</sup> / <sub>6</sub> : <sup>2</sup> / <sub>3</sub> : <sup>1</sup> / <sub>6</sub>	<sup>1</sup> / <sub>6</sub> : <sup>1</sup> / <sub>6</sub> : <sup>2</sup> / <sub>3</sub>
0 mM HCO <sub>3</sub> <sup>-</sup>										
Rb <sub>2</sub> SO <sub>4</sub>	1001.3	500.6				500.6	338.8	600.6	166.9	166.9
K <sub>2</sub> SO <sub>4</sub>		326.4	652.7	326.4			217.6	108.8	435.1	108.8
Na <sub>2</sub> SO <sub>4</sub>				266.3	532.7	266.3	177.6	88.8	88.8	355.1
CaSO <sub>4</sub>	272.3	272.3	272.3	272.3	272.3	272.3	272.3	272.3	272.3	272.3
Ca(NO <sub>3</sub> ) <sub>2</sub> ·4H <sub>2</sub> O	1064.2	1064.2	1064.2	1064.2	1064.2	1064.2	1064.2	1064.2	1064.2	1064.2
NH <sub>4</sub> SO <sub>4</sub>	60.0	60.0	60.0	60.0	60.0	60.0	60.0	60.0	60.0	60.0
Mg(NO <sub>4</sub> ) <sub>2</sub>	513.7	513.7	513.7	513.7	513.7	513.7	513.7	513.7	513.7	513.7
7.5 mM HCO <sub>3</sub> <sup>-</sup>										
RbHCO <sub>3</sub>	1098.8	549.3				549.3	366.2	732.4	183.1	183.1
KHCO <sub>3</sub>		375.5	751.0	375.5			250.3	125.2	500.6	125.5
NaHCO <sub>3</sub>				315.0	630.0	315.0	210.0	105.0	105.0	420.0
Ca(NO <sub>3</sub> ) <sub>2</sub> ·4H <sub>2</sub> O	1064.2	1064.2	1064.2	1064.2	1064.2	1064.2	1064.2	1064.2	1064.2	1064.2
NH <sub>4</sub> SO <sub>4</sub>	60.0	60.0	60.0	60.0	60.0	60.0	60.0	60.0	60.0	60.0
Mg(NO <sub>4</sub> ) <sub>2</sub>	513.7	513.7	513.7	513.7	513.7	513.7	513.7	513.7	513.7	513.7

<sup>z</sup>All solutions contained Fe-DTPA, CuSO<sub>4</sub>·5H<sub>2</sub>O, (NH<sub>4</sub>)<sub>6</sub>Mo<sub>7</sub>O<sub>24</sub>·4H<sub>2</sub>O, H<sub>3</sub>BO<sub>3</sub>, MnCl<sub>2</sub>·4H<sub>2</sub>O as indicated in Table A15



Table A17. Complete 100% strength modified Hoagland's nutrient solution used for establishing seedlings in Experiments 6.5 and 6.6.

Source	mg·L <sup>-1</sup>												
	mg·L <sup>-1</sup>	N	P	K	Ca	Mg	S	Fe	Cu	Zn	Mo	Mn	B
Ca(NO <sub>3</sub> ) <sub>2</sub> ·4H <sub>2</sub> O	1180.8	140.0			200.4								
KNO <sub>3</sub>	505.5	70.3		195.5									
KH <sub>2</sub> PO <sub>4</sub>	136.1		31.0	39.1									
MgSO <sub>4</sub> ·7H <sub>2</sub> O	492.9					48.6	64.1						
Fe-DTPA	50.00							5.0					
CuSO <sub>4</sub> ·5H <sub>2</sub> O	0.08						0.01		0.02				
ZnSO <sub>4</sub> ·5H <sub>2</sub> O	0.22						0.02			0.05			
(NH <sub>4</sub> ) <sub>6</sub> Mo <sub>7</sub> O <sub>24</sub> ·4H <sub>2</sub> O	0.20	0.01									0.11		
H <sub>3</sub> BO <sub>3</sub>	2.86												0.50
MnSO <sub>4</sub> ·H <sub>2</sub> O	1.81						0.38					0.65	
TOTAL (mg·L <sup>-1</sup> )		210.3	31.0	234.6	200.4	48.6	64.5	1.25	0.005	0.013	0.027	0.125	0.125
TOTAL (mM)		15.0	1.0	6.0	5.0	2.0	2.0						

Table A18. Complete nutrient solutions treatments used in Experiments 6.5.

Source	Concentration mM								
	0	2.5	5	7.5	10	15	20	25	30
	KHCO <sub>3</sub>								
KHCO <sub>3</sub>	0.0	249.9	499.8	749.8	999.7	1499.5	1999.3	2499.2	2999.0
Ca(NO <sub>3</sub> ) <sub>2</sub> ·4H <sub>2</sub> O	1563.3	1563.3	1563.3	1563.3	1563.3	1563.3	1563.3	1563.3	1563.3
(NH <sub>4</sub> ) <sub>2</sub> SO <sub>4</sub>	99.1	99.1	99.1	99.1	99.1	99.1	99.1	99.1	99.1
NH <sub>4</sub> NO <sub>3</sub>	19.5	19.5	19.5	19.5	19.5	19.5	19.5	19.5	19.5
MgSO <sub>4</sub> ·7H <sub>2</sub> O	497.0	497.0	497.0	497.0	497.0	497.0	497.0	497.0	497.0
	NaHCO <sub>3</sub>								
NaHCO <sub>3</sub>	0.0	209.7	419.5	629.2	839.9	1258.4	1677.9	2097.4	2516.8
Ca(NO <sub>3</sub> ) <sub>2</sub> ·4H <sub>2</sub> O	1563.3	1563.3	1563.3	1563.3	1563.3	1563.3	1563.3	1563.3	1563.3
NH <sub>4</sub> H <sub>2</sub> PO <sub>4</sub>	99.1	99.1	99.1	99.1	99.1	99.1	99.1	99.1	99.1
(NH <sub>4</sub> ) <sub>2</sub> HPO <sub>4</sub>	19.5	19.5	19.5	19.5	19.5	19.5	19.5	19.5	19.5
K <sub>2</sub> SO <sub>4</sub>	434.0	434.0	434.0	434.0	434.0	434.0	434.0	434.0	434.0
MgSO <sub>4</sub> ·7H <sub>2</sub> O	497.0	497.0	497.0	497.0	497.0	497.0	497.0	497.0	497.0
	Micronutrients mg·L <sup>-1</sup>								
Fe-DTPA	50.0	50.0	50.0	50.0	50.0	50.0	50.0	50.0	50.0
CuSO <sub>4</sub> ·5H <sub>2</sub> O	0.08	0.08	0.08	0.08	0.08	0.08	0.08	0.08	0.08
ZnSO <sub>4</sub> ·5H <sub>2</sub> O	0.22	0.22	0.22	0.22	0.22	0.22	0.22	0.22	0.22
(NH <sub>4</sub> ) <sub>6</sub> Mo <sub>7</sub> O <sub>24</sub> ·4H <sub>2</sub> O	1.48	1.48	1.48	1.48	1.48	1.48	1.48	1.48	1.48
H <sub>3</sub> BO <sub>3</sub>	2.28	2.28	2.28	2.28	2.28	2.28	2.28	2.28	2.28
MnCl <sub>2</sub> ·4H <sub>2</sub> O	1.81	1.81	1.81	1.81	1.81	1.81	1.81	1.81	1.81

Table A19. Nutrient solutions and K<sup>+</sup>:Na<sup>+</sup> binary mixtures used in Experiment 6.6<sup>z</sup>.

	Concentration mg·L <sup>-1</sup>				
	K <sup>+</sup> :Na <sup>+</sup> Binary Blends				
	1:0	<sup>3</sup> / <sub>4</sub> : <sup>1</sup> / <sub>4</sub>	<sup>1</sup> / <sub>2</sub> : <sup>1</sup> / <sub>2</sub>	<sup>1</sup> / <sub>4</sub> : <sup>3</sup> / <sub>4</sub>	0:1
Ca(NO <sub>3</sub> ) <sub>2</sub> ·4H <sub>2</sub> O	1186.0	1186.0	1186.0	1186.0	1186.0
NH <sub>4</sub> NO <sub>3</sub>	120.0	120.0	120.0	120.0	120.0
Mg(NO <sub>3</sub> ) <sub>2</sub>	255.0	255.0	255.0	255.0	255.0
MgSO <sub>4</sub> ·7H <sub>2</sub> O	249.0	249.0	249.0	249.0	249.0
Total K <sup>+</sup> :Na <sup>+</sup> concentration 2.5 mM					
0 mM HCO <sub>3</sub> <sup>-</sup>					
K <sub>2</sub> SO <sub>4</sub>	217.9	163.2	108.4	53.7	
Na <sub>2</sub> SO <sub>4</sub>		44.2	89.5	156.8	177.9
2.5 mM HCO <sub>3</sub> <sup>-</sup>					
KHCO <sub>3</sub>	250.5	188.4	125.3	62.1	
NaHCO <sub>3</sub>		51.6	104.2	156.8	209.5
Total K <sup>+</sup> :Na <sup>+</sup> concentration 5 mM					
0 mM HCO <sub>3</sub> <sup>-</sup>					
K <sub>2</sub> SO <sub>4</sub>	434.7	326.3	217.9	108.4	
Na <sub>2</sub> SO <sub>4</sub>		88.4	177.9	266.3	354.7
5 mM HCO <sub>3</sub> <sup>-</sup>					
KHCO <sub>3</sub>	501.1	375.8	250.5	125.3	
NaHCO <sub>3</sub>		105.3	209.5	314.7	420.0
Total K <sup>+</sup> :Na <sup>+</sup> concentration 7.5 mM					
0 mM HCO <sub>3</sub> <sup>-</sup>					
K <sub>2</sub> SO <sub>4</sub>	652.6	489.5	326.3	163.2	
Na <sub>2</sub> SO <sub>4</sub>		132.6	266.3	400.0	532.6
7.5 mM HCO <sub>3</sub> <sup>-</sup>					
KHCO <sub>3</sub>	750.5	563.2	375.8	187.3	
NaHCO <sub>3</sub>		156.8	314.7	472.6	629.5

<sup>z</sup>Solutions with HCO<sub>3</sub><sup>-</sup> received extra 204.2 mg·L<sup>-1</sup> CaSO<sub>4</sub>; all solutions contained Fe-DTPA, CuSO<sub>4</sub>·5H<sub>2</sub>O, (NH<sub>4</sub>)<sub>6</sub>Mo<sub>7</sub>O<sub>24</sub>·4H<sub>2</sub>O, H<sub>3</sub>BO<sub>3</sub>, MnCl<sub>2</sub>·4H<sub>2</sub>O as indicated in Table A15

## VITA

Luis Alonso Valdez Aguilar was born in Monterrey, N.L. México. He has been married to Juana María Saucedo Rodriguez since 1987 and has one daughter, Anakaren Valdez Saucedo. He received his Bachelor of Science in biology from the Universidad Autónoma de Nuevo León, México (UANL) in 1986. He also received a Master of Science degree in horticulture from Universidad Autónoma Chapingo, México, in 1995. He became a professor in Floriculture, Pot Plant Production, and Greenhouse Management at the Universidad Autónoma Chapingo, where he has been teaching since 1986. His areas of research interests are related to plant nutrition, irrigation management and plant physiology of ornamental plants.

His permanent address is:

Carlota Corday 513  
Col. Jardines Roma.  
Monterrey, N.L. Mexico. CP 64721