

**FLOOD AS AN ECOLOGICAL PERTURBATION
OF EPIGEIC ANIMAL COMMUNITIES.
I. SOME PRELIMINARY HYPOTHESES ON THE APPLICATION
OF CATASTROPHE THEORY BY EVALUATING SOME
MÁRTÉLY—KÖRTVÉLYES DATA**

L. GALLÉ, GY. GYÖRFFY and ELIZABETH H. HORNING

Zoological Department of Attila József University, Szeged
(Received 24 July, 1981)

Abstract

Catastrophe theory seems to be a useful model to study the ecological consequences of flood. The speed of inundation, the size of flooded areas and the time span of flood are important in the formation of jumps of fold catastrophes, size of hysteresis and the time relations of jumps. The possibilities of cusp catastrophe are determined by the number of refuge places.

Recolonization from outer areas consists of two steps: (a) in the immigration phase the increase of size of the initial population is saturation-type and (b) in the multiplication phase it is logistic. The possibilities and proportions of these two steps depend on the migration ability of recolonizing populations and the multiplication strategies of their propagula.

Introduction

The main difficulties in animal ecological investigations of the flood area of River Tisza derive from the floods taking place in every year. The effect of flood is an ecological perturbation that prevents the development of near-to-climax states, structurally constant animal communities and well defined trophic-energetic systems. This means that the methods usually applied to study ecosystems are not sufficient to investigate the structure and energetics of flood area communities. According to above mentioned the results of the ecological investigations have been made in the flood area cannot be generalized in space and time because they refer to different phases of ecological succession after perturbations.

There are several works concerning the effects of flood in the literature of Tisza research but only few authors have investigated the problems of recolonization after floods from quantitative respects. GALLÉ (1972) documented the influence of inundation on the density of ant populations. The effect of flood was also investigated on the structure and productivity of plant communities by BODROGKÖZY and HORVÁTH (1979) and on the recolonizations of Apoidea populations by TANÁCS (1979).

The aim of present work is to give some *a priori* hypotheses on the influence of flood on the structure of animal communities using some known data. Our two basic topics are: 1. role of inundation in the structure of communities and the relevant properties of the succession after flooding; 2. the phases of immigration and recolonization after flooding.

Effects of flood on the community structure

Calculating diversity values from the data of BODROGKÖZY and HORVÁTH (1979) and TANÁCS (1979) by the well known Shannon function it can be seen that the diversity is a good indicator of the changes taking place in the structure after flood (Fig. 1, 2). Diversity increases just after flooding and at the end of the season decreases, from phenological reasons.

To investigate the influence of flood on the diversity of communities we apply one of the relatively new results of mathematical topology, the catastrophe theory (THOM 1969). Catastrophe theory has been widely used in biology, especially in embriogenesis and developmental biology, and also in the modelling of nerve impulses (WOODCOCK 1977). In ecology it has been used for *Choristoneura* — forest system (JONES 1977)

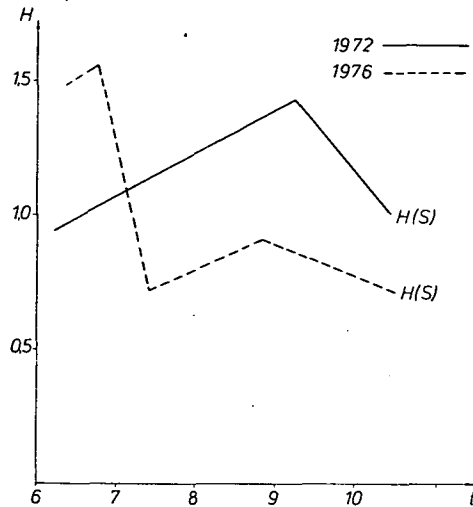

Fig. 1. Changes in diversity of plant communities after flood on the basis of BODROGKÖZY's and HORVÁTH's data (1979).

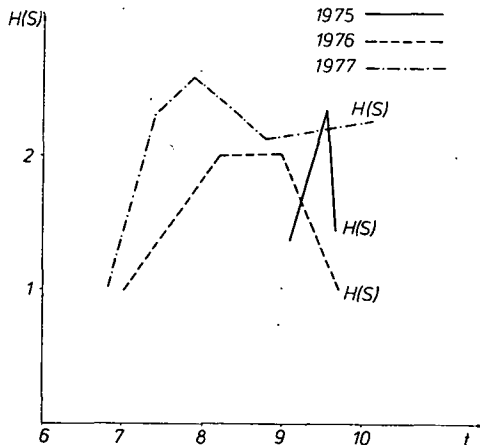

Fig. 2. Changes in diversity of Apoidea community during regeneration after flood, calculated from TANÁCS's (1979) data.

and dutch elm disease (JEFFERS 1978). In its original form this theory investigates the behaviour of the dynamics systems in terms of the maxima and minima of the associated potential energy function. Minima represent stationary or (quasi-) equilibrium states in ecological systems and they are attractants while instable points corresponding to maxima are repellents (JONES 1977). For the study of the influence of flood a starting point can be a system where two attractive and one repellent points can be found (Fig. 3). This very simple two component system (e.g. a primitive com-

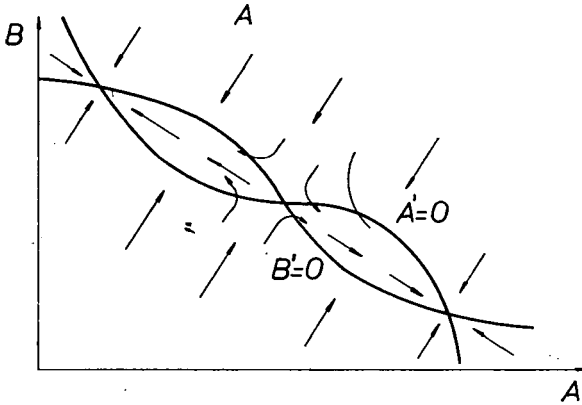

Fig. 3. A simple two component system with one repellent and two attractive points.

petitive phase plain or a cenosystem consisting of two populations) satisfies the bimodality criteria of catastrophe theory. The transition from one stabil state to the other meets the criterium of dicontinuity ("catastrophe"). In the application for the flood

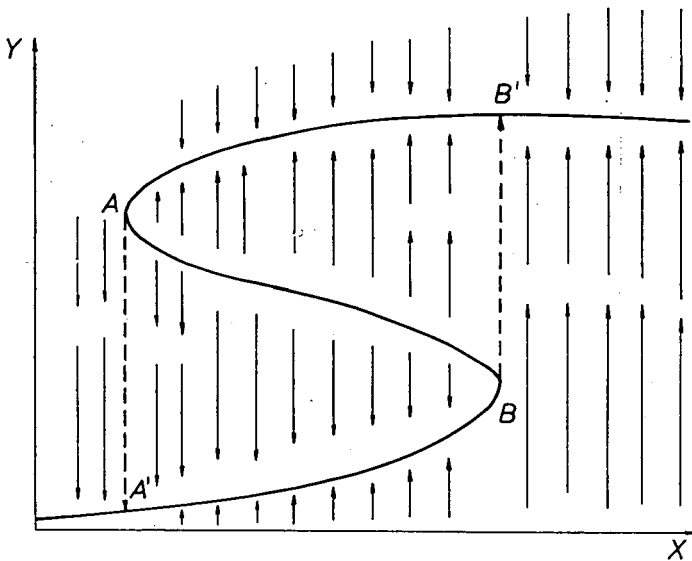

Fig. 4. Hysteresis in a simple fold model of the function between height of flood (x) and the diversity of epigeic animal community.

effect hysteresis is represented by the delayed reaction scheme of the recolonization of the community (Fig. 4): at a given height the water floods the majority of flood areas and kills almost all animals. Surviving individuals concentrate into certain "refuge places" i.e. small dunes, hills, tree trunks etc. As a consequence of flooding such strata that have been transitional refuge places (grass layers, bushes etc.) the level of water has to decrease under the value x corresponding point "B", to the x value of point "A" to let radiation start from refuge places. As a result of this, average diversity (H) increases in the whole area. It is obvious that both the number of refuge places and their ratio to the whole or the flooded area are important: the absence or very small proportion of refuge places don't make a rapid after-flood radiation possible and AA' jumping return is prevented. In this case the recolonization is a slow process by immigration from outer areas and it corresponds to the smooth return in simple cusp. Such a "cusp" scheme is shown in Fig. 5 where $\frac{t}{T} = z$ is the whole area/refuge places ratio, x is the height of the flood and H is the average diversity of the community.

The time span of the inundation is also an important factor. In long lasting water coverage a "refuge place succession" takes place and there are strong selective me-

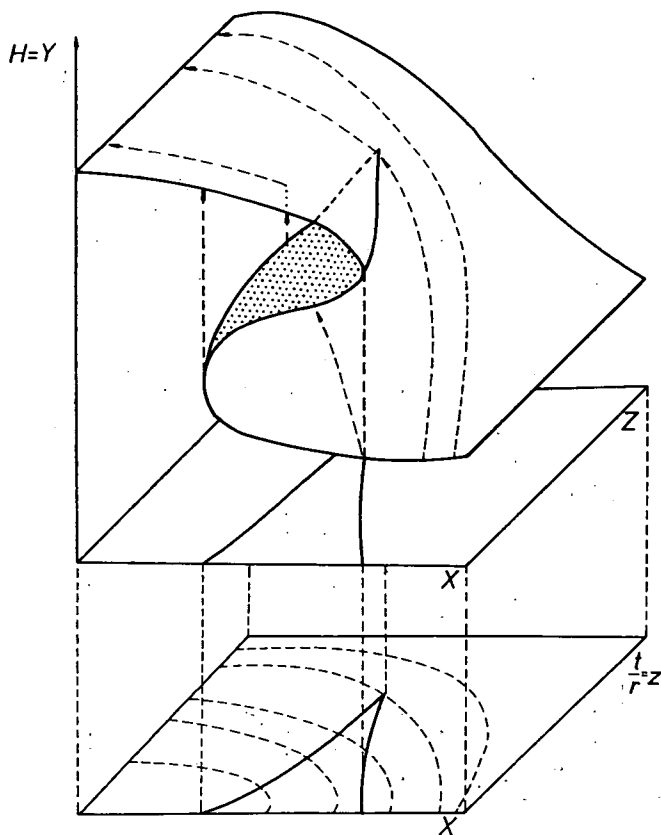

Fig. 5. Cusp catastrophe in the relation of flood height (x); whole area/flood area ratio (z) and diversity.

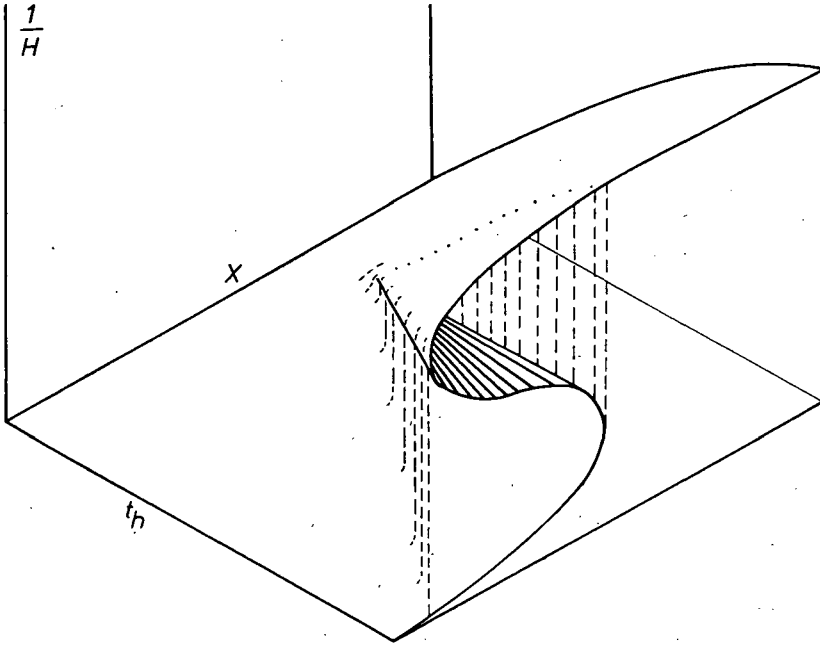

Fig. 6. The effect of height and time span (t_h) of inundations on diversity.

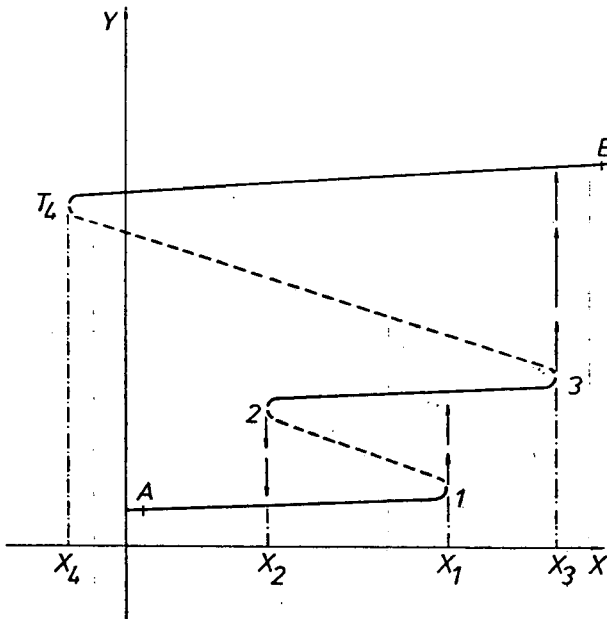

Fig. 7. Supposed behaviour of a structural property of an ecological system as a consequence of perturbations of different intensity (x).

chanisms in it. This selection results a decrease in the diversity of communities in refuge places. In this case diversity can't return to its original value by rapid radiation from refuge places after inundation and a smooth return pattern takes place by immigration (Fig. 6).

Two properties of ecological perturbations can be established on the basis of fold catastrophe (as for 1. see also JONES 1977):

1. Perturbation have to be reduced to a value x_2 much less than the threshold x_1 at which community structure was dramatically changed, to ensure the system to return into its original state (Fig. 7).
2. A second threshold can take place from where there is no return in positive ranges, and for this reason it is an irreversible perturbation that gets the system in that state (x_3 and x_4 in Fig. 7).

Properties of recolonization

Present work deals with two types of recolonizations:

1. Radiation: a rapid distribution of populations from refuge palces without multiplication phase.
2. Immigration: slow process from outer areas. On the basis of a model got on ant populations (Gallé, unpublished), there are two phases of this type (Fig. 8): (a) sensu stricto immigration, when population increase is a saturation-type function of time:

$$\frac{dN}{dt} = a - bN(t)$$

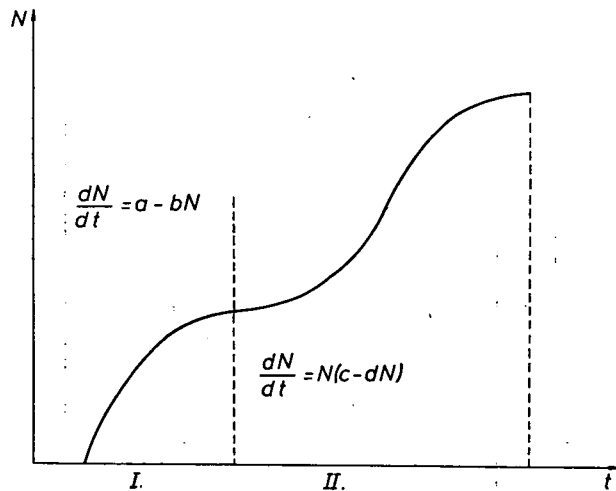

Fig. 8. Two steps of recolonization after flooding.

where N is the size of population; and (b) multiplication phase when multiplication is the most important factor in population growth. In this phase population growth follows a logistic function:

$$\frac{dN}{dt} = N(t)[c - gN(t)].$$

The possibilities and proportions of these two steps depend upon migration ability of populations and ecological strategies of their propagula.

References

- BODROGKÖZY, GY. and HORVÁTH, I. (1979): Effect of lasting floods on the species composition and organic matter production of the marshy-meadow lands in the flood plains of the Tisza. — *Tiscia (Szeged)* 14, 81—88.
- GALLÉ, L. (1972): Formicoidea populations of the ecosystems in the environs of Tiszafüred. — *Tiscia (Szeged)* 7, 59—68.
- JEFFERS, J. N. R. (1978): An introduction to systems analysis: with ecological applications. — London, Arnold.
- JONES, D. D. (1977): Catastrophe theory applied to ecological systems. — *Simulation*, July, 1977, 1—15.
- TANÁCS, L. (1979): Regeneration of the Apoidea insect fauna in the flood area, as a function of ecological conditions. — *Tiscia (Szeged)* 14, 175—186.
- THOM, R. (1969): Topological models in biology. — *Topology* 8, 313—335.
- WOODCOCK, A. E. R. (1977): Catastrophe theory and the modelling of biological systems. — *Lecture Notes in Biomathematics* 18, 342—385.

Az árhullám, mint az epigéikus állatközösségek ökológiai perturbációja.

I. Néhány előzetes hipotézis a katasztrófa elmélet alkalmazásáról, Mártély—Körtvélyesi adatok alapján

GALLÉ L., GYÖRFFY Gy. és H. HORNUNG ERZSÉBET

József Attila Tudományegyetem Állattani Tanszék, Szeged, Magyarország

Kivonat

A tiszakutatás irodalmában igen kevés olyan adat szerepel, amely az árvizeknek az epigéikus állatpopulációk struktúrájára gyakorolt kvantitatív hatására vonatkozik. Ezért a szerzők ezen adatok alapján valószínűsíthető feltevései a priori és munkahipotézis jellegűek: 1. Az árvizek ökológiai konzekvenciáinak tanulmányozására alkalmas modell a katasztrófa elmélet. A föld katasztrófa ugrásainak kialakulásában, a hiszterézis nagyságában, az ugrások idő-relációiban az előntés sebessége, az előntött területek nagysága és az árvíz időtartama játszik fontos szerepet. A cusp típusú katasztrófa kialakulásának lehetőségeit viszont a refugiumok száma határozza meg. 2. A külső területekről történő rekolonizáció két lépésű: a) Az immigrációs fázisban az iniciális populáció nagysága szaturációs; b) amultiplikációs fázisban pedig logisztikus növekedésű. E két lépés alakulásának lehetőségei és egymáshoz viszonyított aránya az újratelepülő populációk migrációs hajlamának, valamint propagulumaik szaporodási stratégiájának függvényei.

Поплава kao ekolo ka perturbacija epigejskih zoocezona. I. Nekoliko prethodnih hipoteza primene teorija katastrofa na osnovu podataka Mértély—Körtvélyes

GALLÉ L., GYÖRFFY GY. i H. HORNING ERZSÉBET

JATE, Állattani Tanszék, Szeged, Hungaria

Abstrakt

O-uticaju poplava na strukturalne odlike epigejskih životinjskih populacija u kvantitativnom pogledu, postoji veoma mali broj podataka u literaturi o istraživanjima reke Tise. Zbog toga, moguće pretpostavke autora, na osnovu tih podataka, su a priori i radnohipotetičnog karaktera:

1. Teorija katastrofa se pojavljuje kao pogodan model za izučavanje ekoloških posledica poplava. U odnosu na skokovite katastrofe, veličinu histereze u razvitku Zemlje, na vremenske relacije katastrofa, značajnu ulogu igra intenzitet poplave, veličina poplavljenog područja i vreme trajanje poplave. Mogućnosti pojave katastrofe tipa cups pak su određeni brojem refugijuma.

2. Rekolonizacija sa okolnih površina je dvojaka:

(a) u fazi imigracije veličine inicijalne populacije je saturacijska,

(b) u fazi multiplikacije pokazuje logistički razvoj.

Mogućnosti i međusobni odnos razvoja ove faze su funkcije migratornih sklonosti kolonističkih populacija i strategije njihovih propaguluma razmnožavanja.

НАВОДНЕНИЯ, КАК ПОВЕРХНОСТНАЯ ЭКОЛОГИЧЕСКАЯ ПЕРЕТУРБАЦИЯ ВЗАИМНЫХ ОТНОШЕНИЙ ЖИВОТНЫХ

ö. Отдельные предварительные гипотезы на основании данных Мартей Кёртвейеш по применению теории катастрофы

Л. Галле, Д. Дьерфи и Э. Хорнунг

Университет им. Йожефа Аттилы, кафедра зоологии, Сегед, Венгрия

Резюме

В литературных источниках мало проводится данных, которые были бы отнесены к квантитативному влиянию наводнений на поверхностную структуру популяции животного мира. В связи с этим, авторы на основании приведенных данных по вероятности постановки вопроса, носящего характер приоритета и рабочего предположения: I. Для изучения экологической последовательности наводнений подходящая моделью является теория катастрофы. В формировании скачков земных катастроф, длительности времени отдельных штампов важную роль играют скорость заливания, величина залитой территории и длительность наводнения. Возникновение катастроф типа «куст» определяет количество рефугимов.

2. Из внешних площадей реколониация проходит в двух фазах: а) В иммиграционной фазе величина инициативной популяции сатуральная; б) В мультипликационной фазе. рост логистический.

Возможность образования двух фаз и взаимных отношений, является результатом образования нововозникших миграционных популяций, а также стратегии размножения пропагулумов.