

# Design of an Energy Harvesting System on Power Transmission Lines

Y Zhuang<sup>1</sup>, C Xu<sup>1</sup>, S Yuan<sup>1</sup>, C He<sup>1</sup>, J Zhou<sup>1</sup>, Y Huang<sup>1</sup>, A Chen<sup>1</sup> and W W. Lee<sup>2</sup>

<sup>1</sup>Department of Electrical Engineering and Electronics, University of Liverpool, L69 3GJ, Liverpool, UK

<sup>2</sup>Zhejiang University of Technology, China<sup>2</sup>

Yuan.Zhuang2@liverpool.ac.uk, Jiafeng.zhou@liverpool.ac.uk, Yi.huang@liverpool.ac.uk, wei.w.lee@hotmail.com

**Abstract**—This paper presents the design, implementation and experimental results of an energy harvesting system to extract energy from power transmission lines. The energy is extracted from a high permeability core clamped on a high alternative current cable. A coil wound on the magnetic core can harvest energy effectively from the cable when the core is operating at the non-saturation region. Little power can be harvested once the magnetic flux density is saturated in the core. This paper introduces a new method to increase the harvested power level. By adding a switch to short circuit the coil when the core saturates, the harvested power can be increased by 27%. To drive a device where higher power is needed, a power management circuit is integrated with the energy harvester. The designed system can provide a power of 792 mW from a 10 A power line, which is sufficient to operate many different types of sensors or communication systems.

**Index Terms** — Energy harvester; high permeability core; magnetic energy; magnetic saturation.

## I. Introduction

Energy harvesting techniques have become more and more popular as alternatives to batteries or external power supplies for low-power applications [1]. There are many sources for energy harvesting such as thermal [2], piezoelectric [3][4] and electromagnetic[5]. An energy harvesting system should provide reliable power to drive devices such as power condition monitoring nodes. The use of electromagnetic induction in close proximity to electrical power lines result in ambient energy being harvested and used to power monitoring devices in remote locations. In these areas constant battery replacement or provision of suitable main power is otherwise difficult. Electromagnetic energy harvesting is very attractive compared to many other methods since it does not rely on external weather conditions such as sunlight or wind. It does not have any moving parts and is almost maintenance free. Standalone magnetic energy harvesters placed a few meters away from power transmission lines were reported in [6][7]. However, the harvested power is very low. This paper explores the design and implementation of a system to improve the power harvested from power transmission lines by clamping the harvester on the lines.

## II. Energy Harvester System

The energy harvester system introduced in this paper consists of two stages as shown in Fig. 1. The first stage is the energy extraction part which includes the harvesting coil with a high permeability core and a control circuit to mitigate the saturation effect. The harvested energy is converted to DC by a bridging circuit. In the second stage, a power management circuit is used to provide higher power to the load with a duty cycle.

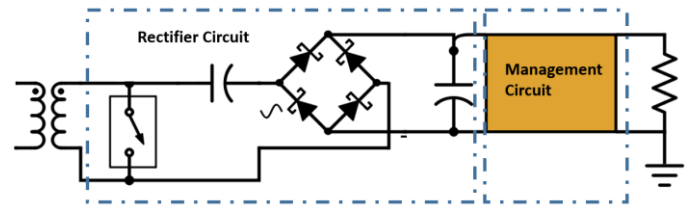

Fig. 1. A circuit diagram of the energy harvesting system.

### A. Energy Extraction

A ring-shape toroidal core is shown in Fig. 2(a). When an electrical cable with a high AC current goes through the core, an alternating magnetic field will be generated. An AC voltage will be induced on the enameled coil wound on the core.

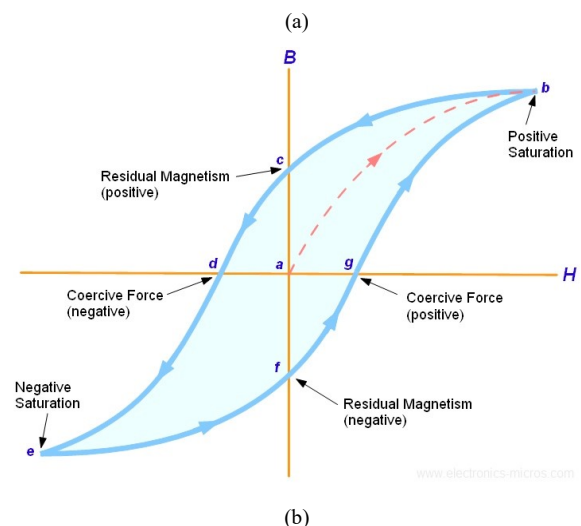
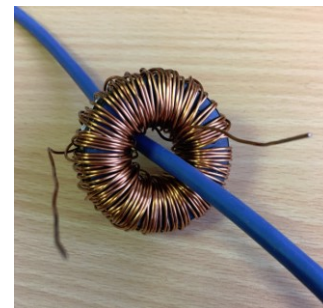

Fig. 2. (a) A coil on a ferromagnetic core and (b) a typical hysteresis loop of ferromagnetic materials [8].

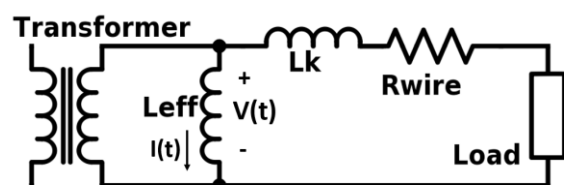

Fig. 3. Secondary side circuit model[11].

The current on a power cable going through the core will generate a magnetic field  $H$ . The magnetic flux density  $B$  in the core is a function of  $H$  as shown in Fig. 2(b). Since power lines usually have high currents. In theory very high power can be harvested if the core has a high permeability. However, most magnetic materials will saturate at a level of several Tesla. The amplitude and variation of the current in the cable will determine if the magnetic flux density  $B$  in the core is saturated or not. When saturated, the flux density in the core does not change anymore, or change very slowly due to the vacuum permeability. Therefore, an accurate model should be established to examine the behavior of the core.

As reported in [9], the core can be modeled as an ideal transformer and a non-ideal inductor shown in Fig. 3.  $L_k$  and  $R_{wire}$  are the leakage inductance and wire resistance respectively, which can be assumed to be zero if the coil length is not too long.  $L_{eff}$  is the inductance of the non-ideal inductor. The voltage and current on this inductor can be expressed as [11]:

$$V(t) = \frac{dFlux(t)}{dt} = \frac{d}{dt} \left[ B_{sat} \cdot \frac{2}{\pi} \arctan\left(\frac{N}{\alpha} I(t)\right) \right] \quad (1)$$

$$= B_{sat} \cdot \frac{2}{\pi} \cdot \left( \frac{\alpha N}{\alpha^2 + N^2 I(t)^2} \right) \frac{dI(t)}{dt}$$

where  $B_{sat}$  is the saturated magnetic flux density of the core,  $Flux(t)$  is the flux in the core,  $I(t)$  is the current going through the core,  $1/\alpha$  is the DC current sensitivity constant in a non-saturated region [9] and  $N$  is the number of the turns wound on the harvesting coil. The effective inductance of the non-ideal inductor can be given by [11]:

$$L_{eff}(t) = \frac{dFlux(t)}{dI(t)} = B_{sat} \cdot \frac{2}{\pi} \cdot \left( \frac{\alpha N}{\alpha^2 + N^2 I(t)^2} \right) \quad (2)$$

Note that most parameters in the equation are the characteristics of the core. Therefore, the inductance of the non-ideal inductor only depends on the current through the core. The relationship between the current in the core and the effective inductance is shown in Fig. 4. At the saturation region when current is high, the inductance of the inductor approaches zero. Very little power can be extracted by the harvesting coil. Therefore, reducing the saturation duration of the magnetic flux can maximize the extracted power.

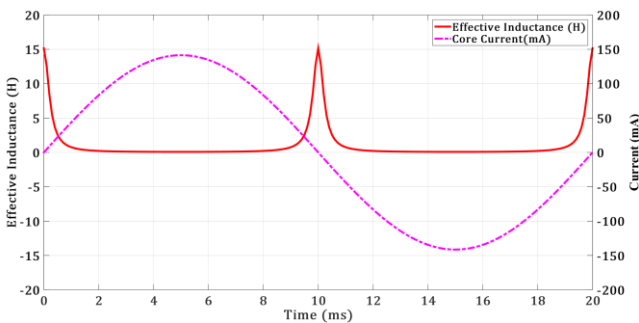

Fig. 4. Current waveform and effective inductance.

To increase the non-saturation time, a switch, shown as S1 in Fig. 1 can be added in parallel with the harvesting coil. The switch is closed for a short duration when the core is saturated. The magnetic flux density will drop to a level lower than  $B_{sat}$ . Then the switch is open until the core is saturated again. The measured voltage waveforms of the

energy harvester on the load by using the proposed method are shown in Fig. 5. The measured waveforms without using the switch are also shown in the same figure. It can be seen that the voltage on the coil is relatively low after the magnitude of the current becomes high. This is because the effective inductance is low when the magnitude of the current is high as given by (2). Compared with the voltage waveform on the coil without a switch, the duration of the non-zero voltage is significantly increased, which means more power has been harvested. The measured results show that the original circuit can harvest 250 mW from a 10A current power line. By adding the switch as shown in Fig. 1, the proposed circuit can harvest 317 mW, 27% higher than the original one.

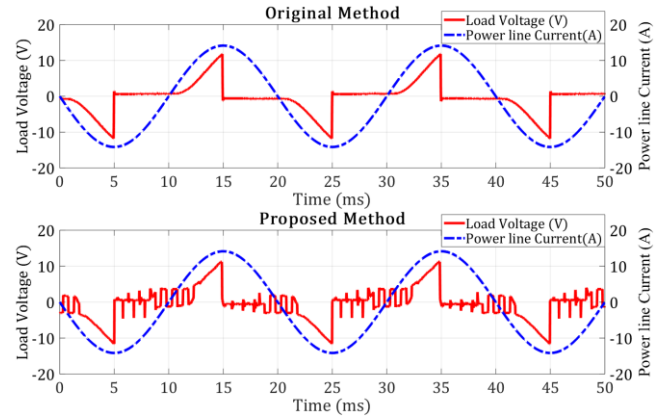

Fig. 5. Voltage waveforms on the coil with (proposed method) or without (original method) the switch S1.

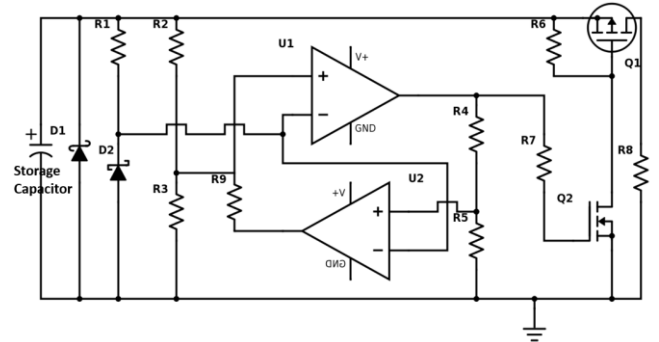

Fig. 6. A diagram of the rectifying circuit and the management circuit.

## B. Management Circuit

Since the core is very compact, the harvested power is still very limited. The maximum output power from the harvester might not be sufficient for many applications. A management circuit was introduced to increase the instantaneous power on the load [12]. This is realized by storing the harvested energy in a capacitor and releasing it within a relatively short time. The instantaneous power over the short time can be much higher than the average power.

The management circuit is shown in Fig. 6. D1 is a Zener diode, which is used to ensure safe dissipation of excess energy. An energy storage capacitor with a capacitance of 4700  $\mu\text{F}$  is added to accumulate energy. Two low supply current comparators U1 and U2, a voltage reference D2 and two MOSFET switches constituted a buffer circuit. R2, R3, R4, R5 and R9 are resistors used for voltage dividing purposes. R1, R6 and R7 are protection resistors.

D2 provided a reference voltage connected to the negative inputs of both comparators. When the harvester

starts to operate, the storage capacitor will be charged. The voltage on the storage capacitor increased from 0 V. When the voltage is increased to a high voltage  $V_H$ , the positive input of the comparator U1 will be higher than the reference voltage on D2. This results in a positive voltage on the gate of Q2, which will turn on the MOSFET. Meanwhile, the comparator U2 will have a high voltage. The MOSFET Q1 will be on once the Q2 is turned on. Thereby, the energy stored in storage capacitor will be supplied to the load. A resistor is used as a load in the measurement. The power consumption on the load is much higher than the level of the harvested power. Energy will be discharged from the storage capacitor and the voltage on storage capacitor will decrease. Once the voltage on the storage capacitor is decreased to a lower voltage  $V_L$ , the positive input of comparator U2 will be lower than its negative input. This results in a 0 V output of U2 and a 0 V output of U1, which will turn off Q1 and Q2. Then the harvested energy began to accumulate in the storage capacitor again [12].

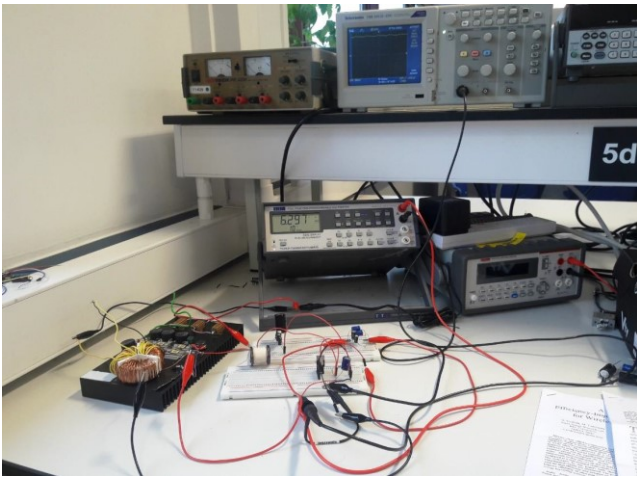

Fig. 7. A photo of measurement setup.

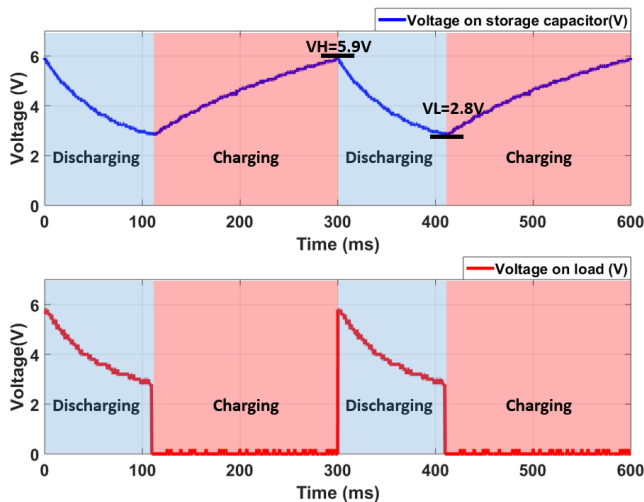

Fig. 8. The measured voltage waveform on the storage capacitor and load.

### III. Implementation of the Measurement

The experimental setup is shown in Fig. 7. The toroidal coil was placed on a cable with an AC current of 10 A. The waveform on the energy storage capacitor is shown in **Error! Reference source not found.** The waveform has a period of 300 ms. In one period, the voltage on the storage capacitor increases for 190 ms from  $V_L$  to  $V_H$ . Then Q1 will

be switched on. The stored energy will be discharged to the load for 110 ms. The voltage on the storage capacitor will decrease from  $V_H$  to  $V_L$ . Then Q1 will be switched off. The capacitor will be charged again.

The measured voltage waveforms on the storage capacitor and load are shown in Fig. 8. The load resistance is 20  $\Omega$ . With the management circuit, the RMS voltage on load, for the duration when Q1 is on, is 3.98 V. The corresponding power on the load is 792 mW for this duration. The peak voltage on load is 6 V, which means the circuit can provide a peak power of at least 1.8 W. A switching mode power supply can be added to the circuit to stabilize the voltage on the load if desired.

### IV. Conclusion

In this paper, a novel method to increase the power harvested from high current conductor with a saturated core is proposed. The magnetic energy harvester has been modelled and analysed. A switch is added in parallel with the harvesting coil to maximize the harvested power. The proposed circuit can harvest 27% more power compared with the original circuit. A power management circuit has been added to boost the output power of the system. The measurement indicated that an output power of 792 mW can be delivered to the load over a period of 110 ms, after being charged for 190 ms. The peak instantaneous power can be up to 1.8W. This design can be a good candidate of many battery-free applications requiring high operating power.

### References

- [1] C. Kompis and S. Aliwell, "Energy harvesting technologies to enable remote and wireless sensing," *Sensors and Instrumentation-Knowledge Transfer Network*, 2008.
- [2] I. Stark, "Invited talk: Thermal energy harvesting with thermo life," in *Wearable and Implantable Body Sensor Networks, 2006. BSN 2006. International Workshop on*, 2006, pp. 19-22.
- [3] K. Cook-Chennault, N. Thambi and A. Sastry, "Powering MEMS portable devices—a review of non-regenerative and regenerative power supply systems with special emphasis on piezoelectric energy harvesting systems," *Smart Mater. Struct.*, vol. 17, pp. 043001, 2008.
- [4] A. Khaligh, P. Zeng and C. Zheng, "Kinetic energy harvesting using piezoelectric and electromagnetic technologies—state of the art," *IEEE Trans. Ind. Electron.*, vol. 57, pp. 850-860, 2010.
- [5] S. Priya and D. J. Inman, *Energy Harvesting Technologies*. Springer, 2009.
- [6] S. Yuan, Y. Huang, J. Zhou, Q. Xu, C. Song and P. Thompson, "Magnetic Field Energy Harvesting Under Overhead Power Lines," *Power Electronics*, *IEEE Transactions on*, vol.30, no.11, pp.6191-6202, Nov. 2015.
- [7] S. Yuan, Y. Huang, J. Zhou, C. Song, Q. Xu and G. Yuan, "A High Efficiency Helical Core for Magnetic Field Energy Harvesting," accepted by in *IEEE Transactions on Power Electronics*, DOI: 10.1109/TPEL.2016.2610323.
- [8] M. Landry, *Elements of electromagnetics*. New York: Oxford University press, 2001.
- [9] J. Moon and S. B. Leeb, "Analysis model for magnetic energy harvesters," *IEEE Transactions on Power Electronics*, vol. 30, pp. 4302-4311, 2015.
- [10] J. Moon and S. B. Leeb, "Power electronic circuits for magnetic energy harvesters," *IEEE Transactions on Power Electronics*, vol. 31, pp. 270-279, 2016.
- [11] J. Moon, J. Donnal, J. Paris, S. Leeb, "VAMPIRE: A magnetically selfpowered sensor node capable of wireless transmission," in *Proc. IEEE 28th Annu. Appl. Power Electron. Conf. Expo.*, Mar. 2013, pp. 3151-3159.
- [12] R. N. M. Roscoe and M. D. Judd, "Harvesting energy from magnetic fields to power condition monitoring sensors," *IEEE Sensors Journal*, vol. 13, pp. 2263-2270, 2013.