

Imperial College London  
Department of Mathematics

**On Mirror Symmetry  
for Fano varieties  
and for singularities**

Andrea Petracci

November 2017

Submitted in partial fulfilment of the requirements for the degree of  
Doctor of Philosophy in Pure Mathematics of Imperial College London



## **Declaration of Originality**

I hereby declare that all material in this dissertation which is not my own work has been properly acknowledged.

## **Copyright Declaration**

The copyright of this thesis rests with the author and is made available under a Creative Commons Attribution Non-Commercial No Derivatives licence. Researchers are free to copy, distribute or transmit the thesis on the condition that they attribute it, that they do not use it for commercial purposes and that they do not alter, transform or build upon it. For any reuse or redistribution, researchers must make clear to others the licence terms of this work



## Acknowledgements

I wish to thank my supervisor Alessio Corti for suggesting the topics of this thesis and for all the help, advice, encouragement, and witticisms he has provided over four years. I am very grateful to Tom Coates for taking care of my work on many occasions.

I want to thank Alessandro Oneto for his patience and his determination during our collaboration. I am grateful to Mark Gross, Paul Hacking, Alexander Kasprzyk, Thomas Prince, and Andrew Strangeway for many useful conversations. I wish to thank Alessandro Chiodo and Richard Thomas for having carefully examined this thesis.

During my Ph.D. I am happy to have known many (mostly Italian) friends in the Huxley building. I would like to thank each of them for interesting discussions about algebraic geometry and other topics, for spending countless lunch breaks together in the common room, for organising the *Book club* and funny charity activities, for travelling together to attend mathematics conferences, and for the good time on the second floor at 15 Westgate Terrace.

Finally, I would like to thank my friends Greta and Lisa, my brother Francesco, my mother Alessandra, and my father Giuseppe, who competently made the pictures appearing in this thesis.



*Ai miei genitori*





# Abstract

In this thesis we discuss some aspects of Mirror Symmetry for Fano varieties and toric singularities.

We formulate a conjecture that relates the quantum cohomology of orbifold del Pezzo surfaces to a power series that comes from Fano polygons. We verify this conjecture in some cases, in joint work with A. Oneto.

We generalise the Altmann–Mavlyutov construction of deformations of toric singularities: from Minkowski sums of polyhedra we construct deformations of affine toric pairs. Moreover, we propose an approach to the study of deformations of Gorenstein toric singularities of dimension 3 in the context of the Gross–Siebert program.

We construct deformations of polarised projective toric varieties by deforming their affine cones. This method is explicit in terms of Cox coordinates and it allows us to give explicit equations for a construction, due to Ilten, which produces a deformation between two toric Fano varieties when their corresponding polytopes are mutation equivalent. We also provide examples of Gorenstein toric Fano 3-folds which are locally smoothable, but not globally smoothable.



# Contents

<b>Introduction</b>	<b>13</b>
Notations and conventions . . . . .	17
<b>1 Mirror Symmetry for Fano varieties</b>	<b>19</b>
1.1 Fano varieties . . . . .	19
1.2 Quantum periods of smooth Fano varieties . . . . .	20
1.3 Fano/Landau–Ginzburg correspondence . . . . .	21
1.4 Mutations of Laurent polynomials . . . . .	23
1.5 Mutations of polytopes . . . . .	24
1.6 Mirror Symmetry for orbifold del Pezzo surfaces I . . . . .	26
<b>2 Quantum periods of del Pezzo surfaces</b>	<b>31</b>
2.1 The quantum period . . . . .	31
2.1.1 Gromov–Witten theory for smooth proper Deligne–Mumford stacks . . . . .	31
2.1.2 Givental’s symplectic formalism . . . . .	33
2.1.3 The quantum period of a Fano orbifold . . . . .	34
2.1.4 Quantum periods of del Pezzo surfaces with $\frac{1}{3}(1, 1)$ singularities	39
2.2 Mirror Symmetry for orbifold del Pezzo surfaces II . . . . .	40
2.3 Toric stacks . . . . .	42
2.3.1 Stacky fans and extended stacky fans . . . . .	42
2.3.2 The mirror theorem for toric stacks . . . . .	45
2.3.3 A toric example: the blow-up of $\mathbb{P}(1, 1, 3)$ at one point. . . . .	46
2.4 Toric complete intersections . . . . .	50
2.4.1 The quantum Lefschetz principle . . . . .	50
2.4.2 Quantum Lefschetz for toric orbifolds . . . . .	53
2.4.3 Example of a toric complete intersection: $X_{2,8/3}$ . . . . .	54
2.4.4 Another example of a toric complete intersection: $B_{1,16/3}$ . . . . .	59
2.5 The Abelian/non-Abelian Correspondence . . . . .	62

2.5.1	Theoretical background . . . . .	62
2.5.2	Example of Abelian/non-Abelian correspondence: $X_{1,7/3}$ . . . . .	64
<b>3</b>	<b>Homogeneous deformations of toric varieties</b>	<b>69</b>
3.1	Preliminaries on toric geometry . . . . .	69
3.2	Deformations of affine toric varieties after A. Mavlyutov . . . . .	72
3.3	Deformations of toric affine pairs . . . . .	82
3.4	Deformations of projective toric varieties . . . . .	86
3.5	Mutations induce deformations . . . . .	94
<b>4</b>	<b>Non-smoothability for some toric threefolds</b>	<b>97</b>
4.1	Deformations of $A_n$ -bundles . . . . .	97
4.2	Toric $A_n$ -bundles over $\mathbb{P}^1$ . . . . .	103
4.3	Deformations of some toric threefolds . . . . .	105
<b>5</b>	<b>Deformations of affine toric varieties à la Gross–Siebert</b>	<b>109</b>
5.1	Gorenstein toric singularities . . . . .	109
5.2	The surface case . . . . .	111
5.2.1	Equations and deformations . . . . .	112
5.2.2	The polyhedral subdivision of $v_0 + \sigma^\vee$ . . . . .	113
5.2.3	The initial scattering diagram . . . . .	114
5.3	The three-dimensional case . . . . .	115
5.3.1	The polyhedral subdivision of $v_0 + \sigma^\vee$ . . . . .	115
5.3.2	The initial scattering diagram . . . . .	116
5.3.3	A conjecture . . . . .	120
5.4	Two examples . . . . .	121
5.4.1	The affine space of dimension 3 . . . . .	121
5.4.2	The singularity $cA_1$ . . . . .	125
	<b>Bibliography</b>	<b>131</b>

# Introduction

Fano varieties are the simplest kind of algebraic varieties and their classification is known only in the smooth case if the dimension is not greater than 3. A program proposed by Coates, Corti, Galkin, Golyshev, and Kasprzyk [CCG<sup>+</sup>14] aims to give a classification of Fano varieties via Mirror Symmetry. On one side there are Fano varieties, whereas on the other side there are combinatorial objects such as polytopes and Laurent polynomials, considered up to an equivalence relation called mutation. We refer the reader to Chapter 1 for details.

In joint work with M. Akhtar, T. Coates, A. Corti, L. Heuberger, A. Kasprzyk, A. Oneto, T. Prince, and K. Tveiten [ACC<sup>+</sup>16], using the general approach of [CCG<sup>+</sup>14], we were able to formulate two conjectures about Mirror Symmetry for mildly singular del Pezzo surfaces. The first conjecture (Conjecture 1.19) establishes a one-to-one correspondence between deformation families of del Pezzo surfaces and mutation equivalence classes of Fano polygons. The second one (Conjecture 2.12) relates the quantum period of a del Pezzo surface  $X$  to a certain power series that comes from the Fano polygon which is associated to  $X$ .

In collaboration with A. Oneto we have verified this second conjecture in some cases:

**Theorem A** (Theorem 2.13). *Let  $P$  be a Fano polygon, let  $X_P$  be the toric del Pezzo surface associated to the spanning fan of  $P$ , let  $X$  be the generic  $\mathbb{Q}$ -Gorenstein deformation of  $X_P$ , and let  $\mathcal{X}$  be the well-formed orbifold with coarse moduli space  $X$ .*

*Let  $\tilde{H}_{\text{CR}}^{\leq 2}(\mathcal{X})$  be the subspace of the Chen–Ruan cohomology of  $\mathcal{X}$  spanned by cohomology classes of degree in  $]0, 2[$  and let  $\hat{G}_{\mathcal{X}}: \tilde{H}_{\text{CR}}^{\leq 2}(\mathcal{X}) \rightarrow \mathbb{Q}[[t]]$  be the regularised quantum period of  $\mathcal{X}$ .*

*Let  $\mathbf{L}^{\text{T}}(P)$  be the affine space of maximally mutable Laurent polynomials of  $P$  with  $T$ -binomial coefficients and let  $\pi: \mathbf{L}^{\text{T}}(P) \rightarrow \mathbb{Q}[[t]]$  be their classical period.*

*Suppose that  $X$  has only  $\frac{1}{3}(1, 1)$  singularities and suppose that either  $K_X^2 \neq \frac{5}{3}$  or the number of singular points of  $X$  is different from 5.*

If natural generalisations of the Quantum Lefschetz theorem (Conjecture 2.18) and of the Abelian/non-Abelian Correspondence (Conjecture 2.23) hold, then there exist a non-empty affine subspace  $W \subseteq \mathbf{L}^T(P)$  and an injective affine-linear map  $\Phi: W \rightarrow \widetilde{\mathbf{H}}_{\mathbb{C}\mathbb{R}}^{\leq 2}(\mathcal{X})$  such that  $\widehat{G}_{\mathcal{X}} \circ \Phi = \pi$ , i.e. the following diagram commutes.

$$\begin{array}{ccc} W & \xrightarrow{\Phi} & \Phi(W) \\ & \searrow \pi & \swarrow \widehat{G}_{\mathcal{X}} \\ & \mathbb{Q}[[t]] & \end{array}$$

We refer the reader to §1.6, §2.1.3, and §2.2 for definitions.

Computing the quantum period of orbifolds is a hard problem in Gromov–Witten theory, and our computations are at the limit of the currently available techniques. Our calculations depend on — and provide strong evidence for — natural conjectural generalisations of the Quantum Lefschetz theorem and the Abelian/non-Abelian Correspondence to the orbifold setting.

In dimensions greater than 2 the situation is more complicated because there are examples of singular toric Fano varieties that can be deformed to two smooth Fano varieties which are not equivalent via smooth deformations. This motivates the study of deformations of toric varieties in the second part of this thesis.

Altmann [Alt95] has noticed that Minkowski decompositions of a polytope contained in a cone  $\sigma$  induce, under some hypotheses, flat deformations of the affine toric variety  $\mathrm{TV}_{\mathbb{C}}(\sigma)$  associated to the cone  $\sigma$ . Mavlyutov [Mav] has generalised Altmann’s construction via Cox coordinates.

We generalise the Altmann–Mavlyutov construction: starting from Minkowski decompositions of some polyhedra with some hypotheses we construct deformations of affine toric pairs. In order to ease the exposition we state only a simpler version of Theorem 3.10.

**Theorem B.** *Let  $N$  be a lattice and let  $\sigma \subseteq N_{\mathbb{R}}$  be a strongly convex rational polyhedral cone of dimension  $\mathrm{rank} N$ . Consider the affine toric variety  $\mathrm{TV}_{\mathbb{C}}(\sigma)$  associated to  $\sigma$ , with its toric boundary  $\partial\mathrm{TV}_{\mathbb{C}}(\sigma)$ . Let  $w \in M := \mathrm{Hom}_{\mathbb{Z}}(N, \mathbb{Z})$  and let  $Q, Q_0, Q_1, \dots, Q_k$  be non-empty rational polyhedra in  $N_{\mathbb{R}}$  such that:*

- $Q_0 \subseteq H_{w, -1} := \{n \in N_{\mathbb{R}} \mid \langle w, n \rangle = -1\}$ ;
- $Q_i \subseteq w^{\perp} = H_{w, 0} := \{n \in N_{\mathbb{R}} \mid \langle w, n \rangle = 0\}$  and  $Q_i$  is a lattice polyhedron, for each  $i = 1, \dots, k$ ;
- $Q = Q_0 + Q_1 + \dots + Q_k \subseteq \sigma$ ;

- every vertex of the polyhedron  $\sigma \cap H_{w,-1}$  belongs to  $Q$ .

Consider the lattice  $\tilde{N} = N \oplus \mathbb{Z}e_1 \oplus \cdots \oplus \mathbb{Z}e_k$  and the cone

$$\tilde{\sigma} = \text{cone} \langle \sigma, Q_0 - e_1 - \cdots - e_k, Q_1 + e_1, \dots, Q_k + e_k \rangle \subseteq \tilde{N}_{\mathbb{R}}.$$

Then:

- $\tilde{\sigma}$  is a strongly convex rational polyhedral cone in  $\tilde{N}$  and the toric morphism  $\text{TV}_{\mathbb{C}}(\sigma) \rightarrow \text{TV}_{\mathbb{C}}(\tilde{\sigma})$ , induced by the inclusion  $(\sigma, N) \hookrightarrow (\tilde{\sigma}, \tilde{N})$ , is a closed embedding and identifies  $\text{TV}_{\mathbb{C}}(\sigma)$  with the closed subscheme of  $\text{TV}_{\mathbb{C}}(\tilde{\sigma})$  associated to the homogeneous ideal generated by the following binomials in the Cox coordinates of  $\text{TV}_{\mathbb{C}}(\tilde{\sigma})$ :

$$\prod_{\substack{\xi \in \tilde{\sigma}(1): \\ \langle e_i^*, \xi \rangle > 0}} x_{\xi}^{\langle e_i^*, \xi \rangle} - \prod_{\substack{\xi \in \tilde{\sigma}(1): \\ \langle e_i^*, \xi \rangle < 0}} x_{\xi}^{-\langle e_i^*, \xi \rangle}$$

for  $i = 1, \dots, k$ ;

- consider the reduced effective divisor  $\mathcal{D}$  in  $\text{TV}_{\mathbb{C}}(\tilde{\sigma})$  defined by the homogeneous ideal generated by the following monomial in the Cox coordinates of  $\text{TV}_{\mathbb{C}}(\tilde{\sigma})$ :

$$\prod_{\substack{\xi \in \tilde{\sigma}(1): \\ \forall i \in \{1, \dots, k\}, \langle e_i^*, \xi \rangle \leq 0}} x_{\xi};$$

then the scheme-theoretic intersection  $\text{TV}_{\mathbb{C}}(\sigma) \cap \mathcal{D}$  coincides with the toric boundary  $\partial \text{TV}_{\mathbb{C}}(\sigma)$  of  $\text{TV}_{\mathbb{C}}(\sigma)$ ;

- consider the closed subscheme  $\mathcal{X}$  of  $\text{TV}_{\mathbb{C}}(\tilde{\sigma}) \times_{\text{Spec } \mathbb{C}} \mathbb{A}_{\mathbb{C}}^k = \text{TV}_{\mathbb{C}[t_1, \dots, t_k]}(\tilde{\sigma})$  defined by the homogeneous ideal generated by the following trinomials in Cox coordinates:

$$\prod_{\substack{\xi \in \tilde{\sigma}(1): \\ \langle e_i^*, \xi \rangle > 0}} x_{\xi}^{\langle e_i^*, \xi \rangle} - \prod_{\substack{\xi \in \tilde{\sigma}(1): \\ \langle e_i^*, \xi \rangle < 0}} x_{\xi}^{-\langle e_i^*, \xi \rangle} - t_i \prod_{\xi \in \tilde{\sigma}(1)} x_{\xi}^{\langle w, \xi \rangle} \prod_{\substack{\xi \in \tilde{\sigma}(1): \\ \langle e_i^*, \xi \rangle < 0}} x_{\xi}^{-\langle e_i^*, \xi \rangle}$$

for  $i = 1, \dots, k$ . Then the morphisms  $\mathcal{X} \cap (\mathcal{D} \times_{\text{Spec } \mathbb{C}} \mathbb{A}_{\mathbb{C}}^k) \hookrightarrow \mathcal{X} \rightarrow \mathbb{A}_{\mathbb{C}}^k$  induce a formal deformation of the toric pair  $(\text{TV}_{\mathbb{C}}(\sigma), \partial \text{TV}_{\mathbb{C}}(\sigma))$  over  $\mathbb{C}[[t_1, \dots, t_k]]$ .

Although the miniversal deformation of a Gorenstein toric isolated singularity is known [Alt97], very little is known if the toric singularity is not isolated. The problem becomes even more difficult if one is interested in deformations of a Gorenstein toric affine pair  $(X, \partial X)$  of dimension greater than or equal to 3.

In Chapter 5 we give a tentative approach to the study of deformations of Gorenstein toric affine pairs of dimension 3 via the Gross–Siebert program. More specifically, we construct a polyhedral complex and an initial scattering diagram on it in such a way that we expect that an appropriate generalisation of the Kontsevich–Soibelman–Gross–Siebert algorithm [GS11a] will produce a deformation of the toric pair.

If one is interested in complete toric varieties, there are some constructions of deformations: Ilten–Vollmert [IV12] and Ilten [Ilt11] use the theory of T-varieties [AH06, AHS08, AIP<sup>+</sup>12], Laface–Melo [LM] use Cox rings, and Mavlyutov [Mav] uses Minkowski sums of polyhedral complexes. But, in general, it is very difficult to give combinatorial input in order to give non locally trivial deformations of singular projective toric varieties. Moreover, the tangent space to deformations of a complete toric variety is not known.

Elaborating on [Ilt12], in §3.4 we show how to adapt Mavlyutov’s approach to construct deformations of polarised projective varieties via deforming their affine cones: this is the content of Theorem 3.12. This procedure allows us to give an explicit description, in terms of Cox coordinates, and an alternative proof of a result due to Ilten [Ilt12]: if two Fano polytopes  $P$  and  $P'$  are mutation equivalent then the corresponding Fano toric varieties  $X_P$  and  $X_{P'}$  are deformation equivalent.

**Theorem C** (Theorem 3.18). *Let  $P \subseteq N_{\mathbb{R}}$  be a Fano polytope and  $w \in M$  be a primitive vector. Let  $F$  be a factor for  $P$  with respect to  $w$  and let  $P' = \text{mut}_w(P, F)$  be the mutated polytope. Let  $X_P$  and  $X_{P'}$  be the toric Fano varieties associated to  $P$  and  $P'$  respectively. Set*

$$\begin{aligned} \text{vert}(P)^{\geq 0} &= \text{vert}(P) \cap \{v \in N \mid \langle w, v \rangle \geq 0\}, \\ \text{vert}(P')^{< 0} &= \text{vert}(P') \cap \{v \in N \mid \langle w, v \rangle < 0\}. \end{aligned}$$

Consider the lattice  $\tilde{N} = N \oplus \mathbb{Z}e_1$  and the polyhedron  $\tilde{Q} \subseteq \tilde{M}_{\mathbb{R}}$  defined by

$$\tilde{Q} = \left\{ u + ke_1^* \in \tilde{M}_{\mathbb{R}} \left| \begin{array}{l} \forall p \in \text{vert}(P)^{\geq 0}, \langle u, p \rangle + 1 \geq 0 \\ \forall p' \in \text{vert}(P')^{< 0}, \langle u, p' \rangle + 1 + k\langle w, p' \rangle \geq 0 \\ \forall f \in \text{vert}(F), \langle u, f \rangle + k \geq 0 \end{array} \right. \right\}.$$

Then  $\tilde{Q}$  is a full dimensional rational polytope and the rays of the normal fan  $\tilde{\Sigma}$  of  $\tilde{Q}$  are

- $p$  for  $p \in \text{vert}(P)^{\geq 0}$ ,



- $p' + \langle w, p' \rangle e_1$  for  $p' \in \text{vert}(P)^{<0}$ ,
- $f + e_1$  for  $f \in \text{vert}(F)$ .

Moreover, if  $\tilde{X} = \text{TV}_{\mathbb{C}}(\tilde{\Sigma})$  is the toric variety associated to  $\tilde{\Sigma}$ , then by varying the coefficients of the trinomial

$$\prod_{p \in \text{vert}(P)^{\geq 0}} x_p^{\langle w, p \rangle} + \prod_{p' \in \text{vert}(P')^{< 0}} x_{p'}^{-\langle w, p' \rangle} + \prod_{f \in \text{vert}(F)} x_f$$

we get a family of closed subschemes of  $\tilde{X}$  over  $\mathbb{P}_{\mathbb{C}}^2$  such that the fibre over  $[0 : 1 : -1]$  is  $X_P$  and the fibre over  $[1 : 0 : -1]$  is  $X_{P'}$ .

Another question that we study in this thesis (Chapter 4) is the smoothability of toric varieties. In dimension 2, it is known that there are no local-to-global obstructions for  $\mathbb{Q}$ -Gorenstein deformations of del Pezzo surfaces ([ACC<sup>+</sup>16, Lemma 6]). This is not the case in dimension 3: indeed we provide examples of Gorenstein Fano toric threefolds which are locally smoothable, but not globally smoothable (Example 4.12). Moreover, we can prove that among the 4319 reflexive polytopes of dimension 3 there are at least 273 polytopes which give a non-smoothable toric Fano variety (Remark 4.15).

Finally, it is worth mentioning that we expect that our approach to deformations of Gorenstein toric singularities of dimension 3 via the Gross–Siebert program (Chapter 5) can be “globalised” to a reflexive 3-tope in order to produce deformations of Gorenstein toric Fano 3-folds.

## Notation and conventions

The sets of non-negative or positive integers are denoted by  $\mathbb{N} := \{0, 1, 2, 3, \dots\}$  and  $\mathbb{N}^+ := \{1, 2, 3, \dots\}$ , respectively. The symbol  $\mathbb{C}$  denotes the field of complex numbers, but more generally often stands for an algebraically closed field of characteristic zero.

A *lattice* is a finitely generated free abelian group. The letters  $N, N_0, N_1, \tilde{N}$  stand for lattices and  $M, M_0, M_1, \tilde{M}$  for their duals, i.e.  $M = \text{Hom}_{\mathbb{Z}}(N, \mathbb{Z})$ . We set  $N_{\mathbb{R}} := N \otimes_{\mathbb{Z}} \mathbb{R}$  and  $M_{\mathbb{R}} := M \otimes_{\mathbb{Z}} \mathbb{R}$ . The perfect pairing  $M \times N \rightarrow \mathbb{Z}$  and its extension to  $M_{\mathbb{R}} \times N_{\mathbb{R}} \rightarrow \mathbb{R}$  are denoted by the symbol  $\langle \cdot, \cdot \rangle$ .

In a real vector space  $V$  of finite dimension, a *cone* is a non-empty subset which is closed under sum and multiplication by non-negative real numbers. The conical hull cone  $\langle S \rangle$  of a subset  $S \subseteq V$  is the smallest cone containing  $S$ , i.e. the set

made up of  $\lambda_1 s_1 + \cdots + \lambda_k s_k$ , as  $k \in \mathbb{N}$ ,  $\lambda_i \geq 0$ , and  $s_i \in S$ . A subset of  $V$  is called a *polyhedral cone* if it coincides with cone  $\langle S \rangle$  for some finite subset  $S \subseteq V$ , or equivalently it is the intersection of a finite number of closed halfspaces passing through the origin. The convex hull of a subset  $S \subseteq V$  is denoted by  $\text{conv} \langle S \rangle$ . A *polyhedron* is the intersection of a finite number of closed halfspaces, so it is always convex and closed. A compact polyhedron is called *polytope*. If  $Q$  is a polyhedron,  $\text{vert}(Q)$  denotes the set of vertices of  $Q$  and  $\text{rec}(Q)$  is its recession cone, i.e. the cone of the unbounded directions of  $Q$ . If  $Q_1$  and  $Q_2$  are polyhedra, then their *Minkowski sum* is  $Q_1 + Q_2 := \{q_1 + q_2 \mid q_1 \in Q_1, q_2 \in Q_2\}$ . If  $Q$  is a polyhedron such that  $\text{rec}(Q)$  is strongly convex, then  $Q = \text{conv} \langle \text{vert}(Q) \rangle + \text{rec}(Q)$ . We refer the reader to the book [Zie95] for details.

We assume the standard terminology of commutative algebra and of algebraic geometry. By a ring we always understand a commutative ring with unit.

# 1

## Mirror Symmetry for Fano varieties

### 1.1. Fano varieties

**Definition 1.1.** A *Fano variety* is a normal projective variety  $X$  over  $\mathbb{C}$  such that its anticanonical divisor  $-K_X$  is  $\mathbb{Q}$ -Cartier and ample. A Fano variety of dimension 2 is called a *del Pezzo surface*.

For a smooth projective variety  $X$  over  $\mathbb{C}$  being Fano is the same as having positive first Chern class:  $c_1(\mathbb{T}_X) > 0$ . Informally speaking, we can say that Fano varieties are ‘positively curved’. They are the simplest kind of varieties in higher birational geometry, as they are the basic building blocks of algebraic varieties according to the Mori program.

The projective line  $\mathbb{P}^1$  is the unique Fano variety of dimension 1. In dimension 2 there are ten deformation families of smooth Fano varieties over  $\mathbb{C}$ :  $\mathbb{P}^1 \times \mathbb{P}^1$  and the blow-ups of the projective plane  $\mathbb{P}^2$  in  $0 \leq m \leq 8$  general points (see [Kol96, Exercise III.3.9] or [Man86, §24]). Iskovskikh [Isk77, Isk78] classified smooth Fano 3-folds with Picard rank 1 and Mori and Mukai [MM81, MM03] classified smooth Fano 3-folds with Picard rank greater than 1: this brings about 105 deformation families of smooth Fano 3-folds. Very little is known in higher dimension. In general, Kollár–Miyaoka–Mori [KMM92] proved that for each  $n$  there are only finitely many deformation families of smooth Fano  $n$ -folds. The following question arises naturally.

**Question 1.2.** *If  $n \geq 4$ , what is the number of deformation families of smooth Fano varieties of dimension  $n$ ?*

Another question is to ask what happens if we allow singularities. Already in dimension 2, there are infinitely many families of singular del Pezzo surfaces. There has been a lot of recent work in birational algebraic geometry about the boundedness of log Fano varieties [HMX14, Bir], but an explicit identification of the connected components of the moduli spaces seems impossible at present.

The program laid out by Coates–Corti–Galkin–Golyshev–Kasprzyk [CCG<sup>+</sup>14] aims for using Mirror Symmetry to give a classification of Fano varieties in terms of combinatorial objects such as polytopes and Laurent polynomials (see §1.3).

## 1.2. Quantum periods of smooth Fano varieties

Let  $X$  be a smooth connected projective variety over  $\mathbb{C}$ . For  $g, n \in \mathbb{N}$  and  $d \in \mathbb{H}_2(X; \mathbb{Z})$ , let  $X_{g,n,d}$  be the moduli stack of stable maps to  $X$  of genus  $g$ , with  $n$  marked points and degree  $d$  [KM94, BM96], equipped with its virtual fundamental class  $[X_{g,n,d}]^{\text{vir}} \in A_{(1-g)(\dim X - 3) - K_X \cdot d + n}(X_{g,n,d})$  [BF97, Beh97] and evaluation maps  $\text{ev}_i: X_{g,n,d} \rightarrow X$  for  $i = 1, \dots, n$ . For any  $i$ , let  $\psi_i \in A^1(X_{g,n,d})$  be the first Chern class of the  $i$ th universal cotangent line bundle over  $X_{g,n,d}$ , that is the line bundle over  $X_{g,n,d}$  whose fibre over the stable map  $(f: C \rightarrow X; p_1, \dots, p_n)$  is  $T_{C,p_i}^\vee$ . For cohomology classes  $\alpha_1, \dots, \alpha_n \in A^\bullet(X)$  and  $k_1, \dots, k_n \in \mathbb{N}$ , the following number is called a *Gromov–Witten invariant* [Beh97]:

$$\langle \alpha_1 \psi^{k_1}, \dots, \alpha_n \psi^{k_n} \rangle_{g,n,d} := \int_{[X_{g,n,d}]^{\text{vir}}} \text{ev}_1^*(\alpha_1) \cup \psi_1^{k_1} \cup \dots \cup \text{ev}_n^*(\alpha_n) \cup \psi_n^{k_n} \in \mathbb{Q}.$$

It is possible to use Betti cohomology and homology instead of Chow groups.

The quantum period of a smooth Fano variety  $X$  is a generating function for some genus zero Gromov–Witten invariants of  $X$ . It is a specialization of a component of Givental’s J-function [Giv96].

**Definition 1.3** ([CCG<sup>+</sup>14, CCGK16]). Let  $X$  be a smooth Fano variety over  $\mathbb{C}$ . Let  $[\text{pt}] \in \mathbb{H}^{2 \dim X}(X; \mathbb{Z})$  be the cohomology class of a point. The *quantum period* of  $X$  is the power series

$$G_X(t) = 1 + \sum_{d \in \mathbb{H}_2(X; \mathbb{Z})} \langle [\text{pt}] \psi^{-K_X \cdot d - 2} \rangle_{0,1,d} t^{-K_X \cdot d} \in \mathbb{Q}[[t]].$$

The *regularised quantum period* of  $X$  is the power series

$$\widehat{G}_X(t) = 1 + \sum_{d \in H_2(X; \mathbb{Z})} (-K_X \cdot d)! \langle [\text{pt}] \psi^{-K_X \cdot d - 2} \rangle_{0,1,d} t^{-K_X \cdot d} \in \mathbb{Q}[[t]].$$

Mori’s cone theorem [Mor82] implies that the sums above are finite in each degree with respect to  $t$ . By [GGI16, Lemma 3.7.4] the quantum period and the regularised quantum period are convergent power series in a neighbourhood of the origin. The quantum periods of smooth Fano varieties of dimension not greater than 3 are computed by Coates–Corti–Galkin–Kasprzyk [CCGK16], thanks to the Givental’s toric mirror theorem [Giv98], the Quantum Lefschetz theorem [CG07], and the Abelian/non-Abelian Correspondence [CFKS08].

We will extend the definition of quantum periods to the case of Fano orbifolds in §2.1.3 and we will compute some restriction of the quantum periods of some del Pezzo surfaces with  $\frac{1}{3}(1, 1)$  singularities (see §2.1.4).

### 1.3. Fano/Landau–Ginzburg correspondence

Mirror Symmetry [CCG<sup>+</sup>14] predicts that the mirror of a smooth Fano  $n$ -fold  $X$  is an  $n$ -fold  $Y$  with a regular function  $W: Y \rightarrow \mathbb{A}^1$ , which is called the *superpotential*. The pair  $(Y, W)$  is called a *Landau–Ginzburg model*. The Gromov–Witten theory of  $X$  should be related to the Hodge theory of the fibration  $W: Y \rightarrow \mathbb{A}^1$ , as follows: the regularised quantum period  $\widehat{G}_X$  of  $X$  coincides with the period  $\pi_W$  which is defined as

$$\pi_W(t) = \int_{\Gamma} \frac{\Omega}{1 - tW} \tag{1.1}$$

where  $\Omega$  is a holomorphic  $n$ -form on  $Y$  and  $\Gamma \in H_n(Y; \mathbb{Z})$  is such that  $\int_{\Gamma} \Omega = 1$ .

Under some circumstances (which conjecturally and experimentally should coincide with when there is a toric degeneration of  $X$ ) there is an open subset of  $Y$  that is isomorphic to the torus  $(\mathbb{C}^\times)^n = \text{Spec } \mathbb{C}[x_1^\pm, \dots, x_n^\pm]$ . In this case the restriction of  $W$  to this open subset gives a Laurent polynomial  $f \in \mathbb{C}[x_1^\pm, \dots, x_n^\pm]$ . In this situation the period  $\pi_W$  in (1.1), when  $Y = (\mathbb{C}^\times)^n$ ,  $\Gamma = \{|x_1| = \dots = |x_n| = 1\}$  and  $\Omega = (2\pi i)^{-n} (x_1 \cdots x_n)^{-1} dx_1 \cdots dx_n$ , gives rise to the following definition.

**Definition 1.4** ([GU10, ACGK12]). The *classical period* of a Laurent polynomial

$f \in \mathbb{C}[x_1^\pm, \dots, x_n^\pm]$  is the power series

$$\begin{aligned} \pi_f(t) &= \left( \frac{1}{2\pi i} \right)^n \int_{|x_1|=\dots=|x_n|=\varepsilon} \frac{1}{1 - tf(x_1, \dots, x_n)} \frac{dx_1 \wedge \dots \wedge dx_n}{x_1 \cdots x_n} \\ &= \sum_{k=0}^{\infty} \text{coeff}_1(f^k) t^k \end{aligned}$$

where  $\text{coeff}_1(f^k) \in \mathbb{C}$  is the coefficient of the monomial  $1 = x_1^0 \cdots x_n^0$  in the Laurent polynomial  $f^k$ .

The equality in the definition above comes from applying  $n$  times Cauchy's integral formula. It is easy to show that  $\pi_f$  is a convergent power series in a neighbourhood of the origin.

A down-to-earth formulation of Mirror Symmetry between smooth Fano varieties and Laurent polynomials is the following.

**Definition 1.5** ([Prz07, CCG<sup>+</sup>14]). A Laurent polynomial  $f \in \mathbb{C}[x_1^\pm, \dots, x_n^\pm]$  is *mirror* to a smooth Fano variety  $X$  of dimension  $n$  if the classical period of the former coincides with the regularised quantum period of the latter:  $\pi_f = \widehat{G}_X$ .

**Remark 1.6.** The equality  $\pi_f = \widehat{G}_X$  can be upgraded to an equality between the Gauss–Manin connection on the middle cohomology of the fibres of  $f$  and the Dubrovin connection of the quantum D-module of  $X$ . We refer the reader to [Gol07].

**Example 1.7** ( $\mathbb{P}^n$ ). Thanks to Givental's toric mirror theorem [Giv98] the quantum period of  $\mathbb{P}^n$  is

$$G_{\mathbb{P}^n} = \sum_{d=0}^{\infty} \frac{1}{(d!)^{n+1}} t^{(n+1)d}.$$

Thus the regularised quantum period is

$$\widehat{G}_{\mathbb{P}^n} = \sum_{d=0}^{\infty} \frac{[(n+1)d]!}{(d!)^{n+1}} t^{(n+1)d}.$$

On the other hand, let us consider the Laurent polynomial

$$f = x_1 + \cdots + x_n + \frac{1}{x_1 \cdots x_n}.$$

It is not difficult to see that

$$\text{coeff}_1(f^k) = \begin{cases} 0 & \text{if } k \notin \mathbb{N}(n+1) \\ \binom{k}{d, \dots, d} & \text{if } k = d(n+1). \end{cases}$$

This shows that  $\widehat{G}_{\mathbb{P}^n} = \pi_f$ . So  $f$  is mirror to  $\mathbb{P}^n$ .

A smooth Fano variety may have many different Laurent polynomial mirrors, which correspond to the many torus charts of its Landau–Ginzburg model. Therefore the following question is natural.

**Question 1.8.** *What are the Laurent polynomial mirrors to a smooth Fano variety?*

In §1.4 we will define an equivalence relation, called *mutation*, among Laurent polynomials that preserves the classical period.

## 1.4. Mutations of Laurent polynomials

Let  $N$  be a lattice and  $M = \text{Hom}_{\mathbb{Z}}(N, \mathbb{Z})$  its dual. Let  $\mathbb{C}(N)$  be the field of rational functions on the torus  $T_M = \text{Spec } \mathbb{C}[N]$ , i.e.  $\mathbb{C}(N)$  is the fraction field of  $\mathbb{C}[N]$ . Every  $A \in \text{GL}(N, \mathbb{Z})$  induces an automorphism of the field  $\mathbb{C}(N)$  defined by  $\chi^u \mapsto \chi^{Au}$  for all  $u \in N$ ; let us denote by  $A$  this field automorphism.

**Definition 1.9** (Algebraic mutation, [GU10, ACGK12]). Let  $N$  be a lattice and let  $M = \text{Hom}_{\mathbb{Z}}(N, \mathbb{Z})$  be the dual lattice. If  $w \in M$  and  $\varphi \in \mathbb{C}[w^\perp \cap N] \subseteq \mathbb{C}[N]$ ,  $\varphi \neq 0$ , then  $\text{mut}_{w, \varphi}$  is the  $\mathbb{C}$ -automorphism of the field  $\mathbb{C}(N)$  defined as

$$\text{mut}_{w, \varphi}: \chi^u \mapsto \varphi^{\langle w, u \rangle} \chi^u$$

for all  $u \in N$ .

An *algebraic mutation* is a  $\mathbb{C}$ -automorphism of the field  $\mathbb{C}(N)$  that can be written as  $A \circ \text{mut}_{w, \varphi}$  for some  $A \in \text{GL}(N, \mathbb{Z})$ ,  $w \in M$  and  $\varphi \in \mathbb{C}[w^\perp]$ .

**Remark 1.10.** On the torus  $T_M = \text{Spec } \mathbb{C}[N]$  there are two natural torus invariant top-dimensional holomorphic forms: namely  $\Omega = \pm(d\chi^{u_1} \wedge \cdots \wedge d\chi^{u_n})/\chi^{u_1 + \cdots + u_n}$ , whenever  $\{u_1, \dots, u_n\}$  is a basis of  $N$ . An algebraic mutation induces a birational map  $\mu: T_M \dashrightarrow T_M$  such that  $\mu^*\Omega = \pm\Omega$ .

Akhtar–Coates–Galkin–Kasprzyk [ACGK12, Lemma 1] show that, if  $f, g \in \mathbb{C}[N]$  are Laurent polynomials and  $\text{mut}: \mathbb{C}(N) \rightarrow \mathbb{C}(N)$  is a mutation such that  $\text{mut}(f) = g$ , then  $f$  and  $g$  have the same classical periods. This sometimes provides a way to construct many Laurent polynomial mirrors to the same smooth Fano variety.

**Example 1.11.** If  $N = \mathbb{Z}^2$ ,  $\mathbb{C}[N] = \mathbb{C}[x^\pm, y^\pm]$ ,  $w = (-1, 2)$  and  $\varphi = 1 + x^2y$ , then  $\text{mut}_{w, \varphi}: \mathbb{C}(x, y) \rightarrow \mathbb{C}(x, y)$  is defined by

$$\begin{aligned} x &\mapsto (1 + x^2y)^{-1}x \\ y &\mapsto (1 + x^2y)^2y. \end{aligned}$$

If  $f = x + y + x^{-1}y^{-1}$  then  $g = \text{mut}_{w,\varphi} = x^{-1}y^{-1} + (1 + x^2y)^2y$ . By Example 1.7  $f$  and  $g$  are both mirror to  $\mathbb{P}^2$ .

## 1.5. Mutations of polytopes

Let  $N$  be a lattice. The *Newton polytope* of a Laurent polynomial  $f = \sum_{v \in N} a_v \chi^v \in \mathbb{C}[N]$  is the convex hull of the lattice points that correspond to the monomials that appear in  $f$ , i.e.  $\text{Newt } f = \text{conv} \langle v \in N \mid a_v \neq 0 \rangle \subseteq N_{\mathbb{R}}$ . One can ask how the Newton polytopes of two mutation equivalent Laurent polynomials are related. This leads to the definition of *combinatorial mutation* (see Definition 1.15).

**Definition 1.12.** A subset  $P \subseteq N_{\mathbb{R}}$  is called a *Fano polytope* if it is a full dimensional polytope such that the origin of  $N$  lies in the strict interior of  $P$  and the vertices of  $P$  are primitive lattice points, i.e. for every vertex  $v$  of  $P$  one has that  $v \in N$  and that there are no other lattice points on the line segment joining  $v$  and the origin.

**Remark 1.13.** Let  $\Sigma$  be a fan of strongly convex rational polyhedral cones in  $N$  and let  $X$  be the corresponding toric variety. Then  $X$  is Fano if and only if  $\Sigma$  is the spanning fan of a Fano polytope  $P$ , i.e. a cone is in  $\Sigma$  if and only if it is the cone over a face of  $P$ . If this is the case the toric variety is usually denoted by  $X_P$ .

If  $M = \text{Hom}_{\mathbb{Z}}(N, \mathbb{Z})$  is the dual lattice,  $w \in M_{\mathbb{R}} \setminus \{0\}$  and  $h \in \mathbb{R}$ , then we denote by  $H_{w,h}$  the set of all points of  $N_{\mathbb{R}}$  lying at height  $h$  with respect to  $w$ , i.e. the affine hyperplane  $H_{w,h} := \{v \in N_{\mathbb{R}} \mid \langle w, v \rangle = h\}$ .

**Definition 1.14.** Let  $P \subseteq N_{\mathbb{R}}$  be a Fano polytope and let  $w \in M$  be a primitive vector. Define<sup>1</sup>  $h_{\min} := \min_P \langle w, \cdot \rangle$  and  $h_{\max} := \max_P \langle w, \cdot \rangle$ . A *factor* of  $P$  with respect to  $w$  is a lattice polytope  $F \subseteq w^{\perp} \subseteq N_{\mathbb{R}}$  satisfying the following condition: for every  $h \in \mathbb{Z}$  such that  $h_{\min} \leq h < 0$ , there exists a (possibly empty) lattice polytope  $G_h \subseteq N_{\mathbb{R}}$  such that

$$H_{w,h} \cap \text{vert}(P) \subseteq G_h + (-h)F \subseteq \text{conv}(H_{w,h} \cap P \cap N). \quad (1.2)$$

Note that, for given Fano polytope  $P \subseteq N_{\mathbb{R}}$  and primitive vector  $w \in M$ , a factor  $F$  need not exist. When a factor does exist we make the following construction.

**Definition 1.15** ([ACGK12, Definition 5]). Let  $P \subseteq N_{\mathbb{R}}$  be a Fano polytope and  $w \in M$  be a primitive vector. Let  $F$  be a factor for  $P$  with respect to  $w$ . Assume that

<sup>1</sup>Since  $P$  is a lattice polytope, both  $h_{\min}$  and  $h_{\max}$  are integers. Since the origin is in the strict interior of  $P$  we have  $h_{\min} < 0 < h_{\max}$ .



$\{G_h\}_{h_{\min} \leq h < 0}$  is a collection of lattice polytopes satisfying the condition in Definition 1.14. We define the corresponding *mutation* to be the lattice polytope

$$\text{mut}_{w,F}(P) := \text{conv} \left( \bigcup_{h=h_{\min}}^{-1} G_h \cup \bigcup_{h=0}^{h_{\max}} ((H_{w,h} \cap P \cap N) + hF) \right).$$

The polytope  $\text{mut}_{w,F}(P)$  does not depend on the choice of  $\{G_h\}_{h_{\min} \leq h < 0}$ . Moreover,  $\text{mut}_{w,F}(P)$  is a Fano polytope. See [ACGK12, §3] or [Akh15, §2.5] for the proofs of these statements.

Roughly speaking,  $\text{mut}_{w,F}(P)$  is obtained from  $P$  by adding  $hF$  at height  $h$  for  $h > 0$  and by removing  $(-h)F$  at height  $h$  for  $h < 0$ .  $F$  is a factor precisely when it is possible to remove multiples of  $F$  at negative heights.

If  $f \in \mathbb{C}[N]$ ,  $w \in M$ ,  $\varphi \in \mathbb{C}[w^\perp \cap N]$  and  $\text{mut}_{w,\varphi}(f) \in \mathbb{C}[N]$ , then there is the following equality of Newton polytopes:

$$\text{Newt } \text{mut}_{w,\varphi}(f) = \text{mut}_{w, \text{Newt } \varphi}(\text{Newt } f).$$

**Remark 1.16.** For every Fano polytope  $P$  in the lattice  $N$ , we can consider the  $T_N$ -toric variety  $X_P$  associated to the spanning fan of  $P$ ; it is a Fano variety. When  $f \in \mathbb{C}[N]$  is a mirror of a smooth Fano variety  $X$  such that  $\text{Newt } f = P$  we expect that  $X_P$  is a degeneration of  $X$ . So mutations of Fano polytopes are related to different toric degenerations of the same smooth Fano variety. In this perspective Ilten [Ilt12] has proved that if  $P$  and  $P'$  are two mutation equivalent Fano polytopes then  $X_P$  and  $X_{P'}$  are two fibres in a flat projective family over  $\mathbb{P}^1$ . We will give an alternate proof of this result in §3.5. Roughly speaking we could say that mutations of Fano polytopes produce a one-dimensional skeleton in the moduli space of Fano varieties.

**Example 1.17.** By Example 1.11 the Laurent polynomials  $f = x + y + x^{-1}y^{-1}$  and  $g = x^{-1}y^{-1} + (1 + x^2y)^2y$  are related via an algebraic mutation. Their Newton polytopes are  $P = \text{conv} \langle (1, 0), (0, 1), (-1, -1) \rangle$  and  $P' = \text{conv} \langle (-1, -1), (0, 1), (4, 3) \rangle$ .

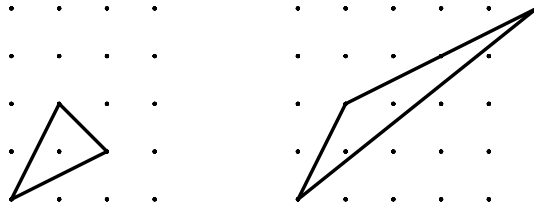

We see that  $X_P = \mathbb{P}^2$  and  $X_{P'} = \mathbb{P}(1, 1, 4)$ . Consider

$$\mathcal{X} = \{([\lambda : \mu], [x_0 : x_1 : x_2 : y]) \in \mathbb{P}^1 \times \mathbb{P}(1, 1, 1, 2) \mid (\lambda + \mu)x_0x_1 - \lambda x_2^2 - \mu y = 0\}$$

with the projection  $\mathcal{X} \rightarrow \mathbb{P}^1$ . The fibre over  $[0 : 1]$  is  $X_P$  and the fibre over  $[1 : 0]$  is  $X_{P'}$ .

## 1.6. Mirror Symmetry for orbifold del Pezzo surfaces I

In the preceding sections we have discussed the Fano/Landau–Ginzburg correspondence and mutations of Laurent polynomials and of Fano polytopes. The discussion has been a bit vague as we do not know what singularities we want Fano varieties to acquire and we do not know what are the Laurent polynomials mirror to any Fano variety. In the case of dimension 2 the description is clearer and leads us to two conjectures which appear in our joint work with Akhtar, Coates, Corti, Heuberger, Kasprzyk, Oneto, Prince, Tveiten [ACC<sup>+</sup>16]. The first conjecture establishes a one-to-one correspondence between Fano polygons, up to mutation, and certain families of del Pezzo surfaces (see Conjecture 1.19 below). This can be seen as a conjectural classification of del Pezzo surfaces.

The del Pezzo surfaces we consider have only *cyclic quotient singularities*. This means that every singular point has a neighbourhood that is a cyclic quotient singularity. By a cyclic quotient singularity of dimension 2 we mean a scheme of finite type over  $\mathbb{C}$  which is étale-locally equivalent to a neighbourhood of the origin in the quotient  $\mathbb{A}^2/\mu_n = \text{Spec } \mathbb{C}[x, y]^{\mu_n}$ , where the group  $\mu_n$  acts linearly with weights  $(1, q)$ , for some  $q, n \in \mathbb{N}$  such that  $1 \leq q < n$  and  $\gcd(n, q) = 1$ . For brevity we denote the quotient  $\mathbb{A}^2/\mu_n$ , with respect to action above, by  $\frac{1}{n}(1, q)$ . It is well known (e.g. [Ful93, §2.2]) that  $\frac{1}{n}(1, q)$  is the affine toric surface associated to cone  $\langle (0, 1), (n, -q) \rangle$  in the lattice  $\mathbb{Z}^2$ . When we write  $\frac{1}{n}(1, q)$  we will always assume that  $q, n \in \mathbb{N}$  are such that  $1 \leq q < n$  and  $\gcd(n, q) = 1$ .

Now we want to specify what sort of families of del Pezzo surfaces with cyclic quotient singularities we allow. Arbitrary flat deformations of normal surfaces can be quite wild; for instance the self-intersection of the canonical divisor in a flat family of normal projective surfaces can be non locally constant. We would like to consider only flat families that behave well with respect to the canonical divisor: this leads us to the notion of a  $\mathbb{Q}$ -Gorenstein family. Roughly speaking, a flat family of normal surfaces is called  $\mathbb{Q}$ -Gorenstein if its relative canonical divisor is a relative  $\mathbb{Q}$ -Cartier divisor. Equivalently,  $\mathbb{Q}$ -Gorenstein deformations of a normal surface are the deformations induced by deformations of its Gorenstein cover stack. This notion is due to Kollár–Shepherd-Barron [KSB88]. We refer the reader to [Kol91, Hac04, AH11, AKb, LN] for precise definitions.

The notion of  $\mathbb{Q}$ -Gorenstein family produces a milder deformation theory. For instance, the base of the miniversal deformation of  $\frac{1}{n}(1, q)$  has many irreducible components [Rie74, KSB88, BR95, Ste91, Chr91, Ste13] and their non-reduced structure is not understood yet. On the other hand, the base space of the miniversal  $\mathbb{Q}$ -Gorenstein deformation is smooth and reduced and can be described explicitly as follows. Write  $w = \gcd(n, q + 1)$ ,  $n = wr$ ,  $q + 1 = wa$ ; it is easy to see that  $r$  is the Gorenstein index of  $\frac{1}{n}(1, q)$  and that the surface  $\frac{1}{n}(1, q)$  is the divisor

$$\{xy + z^w = 0\} \subseteq \frac{1}{r}(1, wa - 1, a)_{x,y,z},$$

where we denote by  $\frac{1}{r}(1, wa - 1, a)$  the quotient  $\mathbb{A}^3/\mu_r$  with respect to the linear action of the cyclic group  $\mu_r$  with weights  $(1, wa - 1, a)$ . If  $r = 1$  (i.e.  $q = n - 1$  and  $\frac{1}{n}(1, n - 1) = A_{n-1}$ ) then every infinitesimal deformation of  $\frac{1}{n}(1, n - 1)$  is  $\mathbb{Q}$ -Gorenstein and the miniversal deformation of  $\frac{1}{n}(1, n - 1)$  is

$$\{xy + z^n + s_1 z^{n-2} + \cdots + s_{n-1} = 0\} \subseteq \mathbb{A}_{x,y,z}^3 \times \mathbb{A}_{s_1, \dots, s_{n-1}}^{n-1}$$

over  $\mathbb{A}^{n-1}$ . If  $r \geq 2$ , then write  $w = mr + w_0$  with  $0 \leq w_0 < r$ , and the miniversal  $\mathbb{Q}$ -Gorenstein deformation of  $\frac{1}{n}(1, q)$  is

$$\{xy + (z^{rm} + s_1 z^{r(m-1)} + \cdots + s_m) z^{w_0} = 0\} \subseteq \frac{1}{r}(1, w_0 a - 1, a)_{x,y,z} \times \mathbb{A}_{s_1, \dots, s_m}^m$$

over  $\mathbb{A}^{m-1}$  and, if  $m \geq 1$ , this is a component of the miniversal deformation of  $\frac{1}{n}(1, q)$ ; the generic fibre of this deformation is smooth if  $w_0 = 0$ , and has a singularity of type  $\frac{1}{w_0 r}(1, w_0 a - 1)$  if  $w_0 > 0$ .

The discussion above leads us to the following definition.

**Definition 1.18** ([AKa]). Let  $n, q \in \mathbb{N}$  be such that  $1 \leq q < n$  and  $\gcd(n, q) = 1$ . Set  $w = \gcd(n, q + 1)$ ,  $n = wr$ ,  $q + 1 = wa$ ,  $w = mr + w_0$  with  $0 \leq w_0 < r$ . The *residual singularity* of  $\frac{1}{n}(1, q)$  is defined as

$$\text{res} \left( \frac{1}{n}(1, q) \right) = \begin{cases} \frac{1}{w_0 r}(1, w_0 a - 1) & \text{if } w_0 > 0 \\ \emptyset & \text{if } w_0 = 0. \end{cases}$$

The singularity  $\frac{1}{n}(1, q)$  is called  *$\mathbb{Q}$ -Gorenstein rigid* if  $0 < w < r$ .

In other words, the residual singularity of  $\frac{1}{n}(1, q)$  is the best singularity to which  $\frac{1}{n}(1, q)$  can be  $\mathbb{Q}$ -Gorenstein deformed. Moreover, the singularity  $\frac{1}{n}(1, q)$  is  $\mathbb{Q}$ -Gorenstein rigid if all infinitesimal  $\mathbb{Q}$ -Gorenstein deformations are trivial.

We say that two normal surfaces  $X$  and  $X'$  are  $\mathbb{Q}$ -Gorenstein deformation equivalent if there exist  $\mathbb{Q}$ -Gorenstein families  $f_i: \mathcal{X}_i \rightarrow S_i$  over connected schemes  $S_i$  of finite type over  $\mathbb{C}$  and closed points  $t_i, s_i \in S_i$ ,  $1 \leq i \leq n$ , such that  $X = f_1^{-1}(t_1)$ ,  $f_i^{-1}(s_i) = f_{i+1}^{-1}(t_{i+1})$  for  $1 \leq i < n$ , and  $f_n^{-1}(s_n) = X'$ .

A *Fano polygon* is a Fano polytope of dimension 2. Two Fano polygons  $P$  and  $P'$  are *mutation equivalent* if there is a sequence of combinatorial mutations that starts with  $P$  and ends at  $P'$ .

**Conjecture 1.19** ([ACC<sup>+</sup>16, Conjecture A]). *Let  $\mathfrak{P}$  be the set of mutation equivalence classes of Fano polygons. Let  $\mathfrak{F}$  be the set of  $\mathbb{Q}$ -Gorenstein deformation equivalence classes of del Pezzo surfaces  $X$  with  $\mathbb{Q}$ -Gorenstein rigid cyclic quotient singularities and with a  $\mathbb{Q}$ -Gorenstein degeneration to a toric del Pezzo surface.*

*Then the assignment, to a Fano polygon  $P$ , of a generic  $\mathbb{Q}$ -Gorenstein deformation of the toric surface  $X_P$  is a bijection from  $\mathfrak{P}$  to  $\mathfrak{F}$ .*

This conjecture can be interpreted as a classification of the connected components of the moduli stack of del Pezzo surfaces with  $\mathbb{Q}$ -Gorenstein toric degeneration.

**Theorem 1.20** ([ACC<sup>+</sup>16, Theorem 3]). *The assignment in Conjecture 1.19 gives a surjective map  $\mathfrak{P} \rightarrow \mathfrak{F}$ .*

The proof of the theorem above is contained in [ACC<sup>+</sup>16] and runs as follows. If  $P$  and  $P'$  are two mutation equivalent Fano polygons, then the corresponding toric del Pezzo surfaces  $X_P$  and  $X_{P'}$  are  $\mathbb{Q}$ -Gorenstein deformation equivalent, similarly as in Remark 1.16. If  $P$  is a Fano polygon then the generic  $\mathbb{Q}$ -Gorenstein deformation of  $X_P$  contains only  $\mathbb{Q}$ -Gorenstein rigid cyclic quotient singularities, because there are no local-to-global obstructions for  $\mathbb{Q}$ -Gorenstein deformations of del Pezzo surfaces.

Kasprzyk–Nill–Prince [KNP] have proved that there are 10 mutation equivalence classes of Fano polygons  $P$  such that  $X_P$  has only  $\mathbb{Q}$ -Gorenstein smoothable singularities. These means that, according to Conjecture 1.19, they correspond to the 10 deformation families of smooth del Pezzo surfaces.

One can easily see that  $\frac{1}{3}(1, 1)$  is a  $\mathbb{Q}$ -Gorenstein rigid singularity. Let us consider Fano polygons  $P$  such that the residual singularities of the singularities of the toric surface  $X_P$  are empty or  $\frac{1}{3}(1, 1)$ , and they are not all empty. Equivalently, we are considering Fano polygons  $P$  such that the generic  $\mathbb{Q}$ -Gorenstein deformation of  $X_P$  is singular and has only  $\frac{1}{3}(1, 1)$  as singularities. By [KNP], there are 26 mutation classes of such polygons. These correspond to the 26  $\mathbb{Q}$ -Gorenstein families of del Pezzo surfaces with a toric  $\mathbb{Q}$ -Gorenstein degeneration and with  $\frac{1}{3}(1, 1)$  singularities, which have been classified by Corti and Heuberger [CH17]. In addition, there are 3  $\mathbb{Q}$ -Gorenstein deformation equivalence classes of del Pezzo surfaces with  $\frac{1}{3}(1, 1)$

singularities without a  $\mathbb{Q}$ -Gorenstein toric degeneration: we expect that there is no torus chart on their Landau–Ginzburg models.

The discussion of Mirror Symmetry for orbifold del Pezzo surfaces will continue in §2.2.



# 2

## Quantum periods of del Pezzo surfaces with $\frac{1}{3}(1, 1)$ singularities

In this chapter we recall the Gromov–Witten theory for orbifolds and we define the quantum period for Fano orbifolds (§2.1). In §2.2 we continue our discussion of Mirror Symmetry for orbifold del Pezzo surfaces. In §2.1.4 we summarise the results of the computation, done in collaboration with Alessandro Oneto [OP], of the quantum periods for del Pezzo surfaces with  $\frac{1}{3}(1, 1)$  singularities and we discuss methods and examples in §2.3, §2.4, and §2.5.

### Notation

In this chapter calligraphic letters, i.e.  $\mathcal{X}$  and  $\mathcal{Y}$ , denote separated Deligne–Mumford stacks of finite type over  $\mathbb{C}$  and roman letters, i.e.  $X$  and  $Y$ , denote their coarse moduli spaces.

## 2.1. The quantum period

### 2.1.1. Gromov–Witten theory for smooth proper Deligne–Mumford stacks

Gromov–Witten theory for smooth proper Deligne–Mumford stacks has been developed by Chen–Ruan [CR04] in the symplectic setting and by Abramovich–Graber–

Vistoli [AGV02, AGV08] in the algebraic setting. Here we recall just the basic definitions, following the concise expositions of [Iri11, §2.1] and [CCIT15].

Let  $\mathcal{X}$  be a proper smooth Deligne–Mumford stack over  $\mathbb{C}$  with projective coarse moduli space  $X$ . Let

$$\mathbf{I}\mathcal{X} = \coprod_{b \in \text{Box}(\mathcal{X})} \mathcal{X}_b$$

be the decomposition of the inertia stack of  $\mathcal{X}$  into connected components. Let  $0 \in \text{Box}(\mathcal{X})$  be the index of the connected component of  $\mathbf{I}\mathcal{X}$  corresponding to the trivial stabiliser. For every  $b \in \text{Box}(\mathcal{X})$ , let  $\text{age}(b) \in \mathbb{Q}_{\geq 0}$  be the *age* of the component  $\mathcal{X}_b$  (see [CR04, §3.2], where it is called degree shifting number, or [AGV08, §7.1]). Let  $\mathbf{H}_{\text{CR}}^\bullet(\mathcal{X})$  be the even part of the *Chen–Ruan orbifold cohomology group* of  $\mathcal{X}$ , i.e. the  $\mathbb{Q}$ -graded vector space over  $\mathbb{Q}$  given by

$$\mathbf{H}_{\text{CR}}^p(\mathcal{X}) := \bigoplus_{\substack{b \in \text{Box}(\mathcal{X}) \text{ s.t.} \\ p - 2\text{age}(b) \in 2\mathbb{Z}}} \mathbf{H}^{p-2\text{age}(b)}(\mathcal{X}_b; \mathbb{Q})$$

for every  $p \in \mathbb{Q}$ . Thus  $\mathbf{H}_{\text{CR}}^\bullet(\mathcal{X})$  coincides, as a vector space, with the even degree cohomology  $\mathbf{H}^{\text{even}}(\mathbf{I}\mathcal{X}; \mathbb{Q})$  of  $\mathbf{I}\mathcal{X}$ , but has a different grading. Let  $\text{inv}^*: \mathbf{H}_{\text{CR}}^\bullet(\mathcal{X}) \rightarrow \mathbf{H}_{\text{CR}}^\bullet(\mathcal{X})$  be the homomorphism induced by the involution  $\text{inv}: \mathbf{I}\mathcal{X} \rightarrow \mathbf{I}\mathcal{X}$  given by  $(x, g) \mapsto (x, g^{-1})$ . The *orbifold Poincaré pairing*  $(\cdot, \cdot)_{\text{CR}}$  is the symmetric non-degenerate bilinear form on  $\mathbf{H}_{\text{CR}}^\bullet(\mathcal{X})$  defined by

$$(\alpha, \beta)_{\text{CR}} := \int_{\mathbf{I}\mathcal{X}} \alpha \cup \text{inv}^* \beta.$$

For  $d \in \mathbf{H}_2(X; \mathbb{Z})$  and  $n \geq 0$ , let  $\mathcal{X}_{0,n,d}$  be the *moduli stack of stable maps*<sup>1</sup> to  $\mathcal{X}$  of genus 0, with  $n$  marked points and degree  $d$ . This is equipped with a virtual fundamental class  $[\mathcal{X}_{0,n,d}]^{\text{vir}} \in \mathbf{H}_\bullet(\mathcal{X}_{0,n,d}; \mathbb{Q})$  and evaluation maps  $\text{ev}_i: \mathcal{X}_{0,n,d} \rightarrow \mathbf{I}^{\text{rig}}\mathcal{X}$  to the rigidified inertia stack  $\mathbf{I}^{\text{rig}}\mathcal{X}$  (see [AGV08, §3.4]), for  $i = 1, \dots, n$ . Since the stacks  $\mathbf{I}^{\text{rig}}\mathcal{X}$  and  $\mathbf{I}\mathcal{X}$  have the same coarse moduli space, there are canonical isomorphisms between their cohomology groups with rational coefficients. Thus, we can think of elements of  $\mathbf{H}_{\text{CR}}^\bullet(\mathcal{X})$  as cohomology classes on  $\mathbf{I}^{\text{rig}}\mathcal{X}$ . For  $i = 1, \dots, n$ , let  $\psi_i \in \mathbf{H}^2(\mathcal{X}_{0,n,d}; \mathbb{Q})$  be the first Chern class of the  $i$ th universal cotangent line bundle  $\mathcal{L}_i \in \text{Pic}(\mathcal{X}_{0,n,d})$ . *Gromov–Witten invariants* of  $\mathcal{X}$  are numbers

$$\langle \alpha_1 \psi^{k_1}, \dots, \alpha_n \psi^{k_n} \rangle_{0,n,d} := \int_{[\mathcal{X}_{0,n,d}]^{\text{vir}}} \prod_{i=1}^n (\text{ev}_i^*(\alpha_i) \cup \psi_i^{k_i}) \in \mathbb{Q},$$

<sup>1</sup>This is an open and closed substack of the stack of balanced twisted stable maps  $\mathcal{K}_{0,n}^{\text{bal}}(\mathcal{X}, \mathcal{O}_X(1), d)$  in [AV02], where  $\mathcal{O}_X(1)$  is an ample line bundle on  $X$ .



where  $\alpha_1, \dots, \alpha_n \in H_{\text{CR}}^\bullet(\mathcal{X})$  are cohomology classes and  $k_1, \dots, k_n$  are non-negative integers.

### 2.1.2. Givental's symplectic formalism

Let  $\mathcal{X}$  be a proper smooth Deligne–Mumford stack over  $\mathbb{C}$  with projective coarse moduli space  $X$ . Let  $\text{Eff}(\mathcal{X}) \subseteq H_2(X; \mathbb{Z})$  be the submonoid generated by the homology classes of images of representable maps from complete stacky curves to  $\mathcal{X}$ . If  $R$  is a commutative ring, then the *Novikov ring*  $\mathbf{\Lambda}(R)$  on  $R$  is the completion of the group  $R$ -algebra  $R[\text{Eff}(\mathcal{X})]$  with respect to an additive valuation defined by a polarization on  $X$  which we choose once and for all (see [Tse10, Definition 2.5.4]). If  $d \in \text{Eff}(\mathcal{X})$  we denote by  $Q^d$  the corresponding element in  $\mathbf{\Lambda}(R)$ . Following Givental [Giv01] and Tseng [Tse10], we consider the  $\mathbb{C}$ -vector space

$$\mathcal{H}_{\mathcal{X}} := H_{\text{CR}}^\bullet(\mathcal{X}) \otimes_{\mathbb{Q}} \mathbf{\Lambda}(\mathbb{C}((z^{-1}))), \quad (2.1)$$

where  $z$  is a formal variable, equipped with the symplectic form  $\Omega$  defined by

$$\Omega(f, g) = -\text{Res}_{z=\infty}(f(-z), g(z))_{\text{CR}} dz \quad \text{for } f, g \in \mathcal{H}_{\mathcal{X}}.$$

In the symplectic vector space  $(\mathcal{H}_{\mathcal{X}}, \Omega)$  there is a Lagrangian submanifold  $\mathcal{L}_{\mathcal{X}}$ , which is a formal germ of a cone with vertex at the origin and which encodes all genus-zero Gromov–Witten invariants of  $\mathcal{X}$ . We will not give a precise definition of  $\mathcal{L}_{\mathcal{X}}$  here, referring the reader to [Tse10, §3.1], [CCIT09, Appendix B] and [CCIT15, §2].  $\mathcal{L}_{\mathcal{X}}$  is called the *Givental cone* of  $\mathcal{X}$  and determines and is determined by Givental's *J-function*:

$$J_{\mathcal{X}}(\gamma, z) = z + \gamma + \sum_{d \in \text{Eff}(\mathcal{X})} \sum_{n=0}^{\infty} \sum_{k=0}^{\infty} \sum_{\epsilon=1}^N \frac{Q^d}{n!} \langle \gamma, \dots, \gamma, \phi^\epsilon \psi^k \rangle_{0, n+1, d} \phi_\epsilon z^{-k-1}, \quad (2.2)$$

where  $\gamma$  runs in  $H_{\text{CR}}^\bullet(\mathcal{X})$ , and  $\{\phi_1, \dots, \phi_N\}$  and  $\{\psi^1, \dots, \psi^N\}$  are homogeneous bases of the vector space  $H_{\text{CR}}^\bullet(\mathcal{X})$  which are dual with respect to  $(\cdot, \cdot)_{\text{CR}}$ . The cone  $\mathcal{L}_{\mathcal{X}}$  determines the J-function because  $J_{\mathcal{X}}(\gamma, -z)$  is the unique point on  $\mathcal{L}_{\mathcal{X}}$  of the form  $-z + \gamma + O(z^{-1})$ , where  $O(z^{-1})$  denotes a power series in  $z^{-1}$ . Conversely, the J-function determines  $\mathcal{L}_{\mathcal{X}}$  and all genus-zero Gromov–Witten invariants of  $\mathcal{X}$  by [GT13, Proposition 2.1] and topological recursion relations.

### 2.1.3. The quantum period of a Fano orbifold

An *orbifold* is defined to be a separated smooth connected Deligne–Mumford stack  $\mathcal{X}$  of finite type over  $\mathbb{C}$  such that the stabiliser of the generic point is trivial. Following [IF00, Definition 5.11], we say that an orbifold  $\mathcal{X}$  is *well-formed*<sup>2</sup> if the natural morphism  $\mathcal{X} \rightarrow X$  to the coarse moduli space is an isomorphism in codimension 1. In other words, an orbifold is well-formed if the stacky locus has codimension at least 2.

If  $\mathcal{X}$  is a well-formed orbifold and its coarse moduli space  $X$  is a scheme, then  $X$  is a Cohen–Macaulay  $\mathbb{Q}$ -factorial normal variety with quotient singularities such that  $\mathrm{Pic}(\mathcal{X}) \simeq \mathrm{Pic}(X_{\mathrm{sm}}) \simeq \mathrm{Cl}(X)$ , where  $X_{\mathrm{sm}}$  is the smooth locus of  $X$  and  $\mathrm{Cl}(X)$  is the divisor class group of  $X$ . Conversely, a normal separated variety with quotient singularities is the coarse moduli space of a unique well-formed orbifold, by [Vis89, (2.8) and (2.9)] and [FMN10, §4.1]. In other words, there is a one-to-one correspondence between well-formed orbifolds with schematic coarse moduli space and normal separated varieties with quotient singularities.

When  $X$  is a normal separated variety with quotient singularities, we denote by  $\mathcal{X}$  the unique well-formed orbifold such that  $X$  is its coarse moduli space.

**Definition 2.1.** A well-formed orbifold  $\mathcal{X}$  is called a *Fano orbifold* if its coarse moduli space  $X$  is a projective variety such that its anticanonical class  $-K_X$  is an ample  $\mathbb{Q}$ -Cartier divisor.

There is a one-to-one correspondence between Fano orbifolds and normal projective varieties with quotient singularities such that  $\mathcal{O}_X(-mK_X)$  is a very ample line bundle on  $X$ , for some  $m \geq 1$ .

The quantum period of a Fano orbifold  $\mathcal{X}$  is a generating function for certain genus-zero Gromov–Witten invariants of  $\mathcal{X}$ .

**Definition 2.2** ([OP]). Let  $\mathcal{X}$  be a Fano orbifold and let  $b_1, \dots, b_r \in \mathrm{Box}(\mathcal{X})$  be the indices of the connected components of the inertia stack  $I\mathcal{X}$  such that  $0 < \mathrm{age}(b_i) < 1$ . Let  $\mathbf{1}_{b_i} \in H^0(\mathcal{X}_{b_i}; \mathbb{Q}) \subseteq H_{\mathrm{CR}}^{2\mathrm{age}(b_i)}(\mathcal{X})$  be the identity cohomology class of the component  $\mathcal{X}_{b_i}$ . If  $d \in \mathrm{Eff}(\mathcal{X})$ ,  $n \in \mathbb{N}$  and  $1 \leq i_1, \dots, i_n \leq r$ , then set

$$\delta_{d, i_1, \dots, i_n} := -K_X \cdot d + \sum_{j=1}^n (1 - \mathrm{age}(b_{i_j})) \in \mathbb{Q}.$$

---

<sup>2</sup>A well-formed orbifold is called a canonical smooth Deligne–Mumford stack by Fantechi–Mann–Nironi [FMN10, Def. 4.4].

The *quantum period* of  $\mathcal{X}$  is:

$$G_{\mathcal{X}}(x_1, \dots, x_r; t) = 1 + \sum_{d \in \text{Eff}(\mathcal{X})} \sum_{n=0}^{\infty} \sum_{1 \leq i_1, \dots, i_n \leq r} \left\langle \mathbf{1}_{b_{i_1}}, \dots, \mathbf{1}_{b_{i_n}}, \frac{\phi_{\text{vol}}}{1-\psi} \right\rangle_{0, n+1, d} \frac{x_{i_1} \cdots x_{i_n}}{n!} t^{\delta_{d, i_1, \dots, i_n}},$$

where  $\phi_{\text{vol}} \in H^{2 \dim \mathcal{X}}(\mathcal{X}; \mathbb{Q})$  is the cohomology class of a point,  $t, x_1, \dots, x_r$  are formal variables and  $\frac{1}{1-\psi}$  denotes the series  $\sum_{k \geq 0} \psi^k$ .

If  $G_{\mathcal{X}} = \sum_{\delta \in \mathbb{N}} c_{\delta} t^{\delta}$  is the quantum period of  $\mathcal{X}$  with  $c_{\delta} \in \mathbb{Q}[[x_1, \dots, x_r]]$ , then the *regularised quantum period* of  $\mathcal{X}$  is  $\widehat{G}_{\mathcal{X}} := \sum_{\delta \in \mathbb{N}} \delta! c_{\delta} t^{\delta}$ .

The quantum period comes from a specialisation of a component of the J-function. Indeed,  $G_{\mathcal{X}}$  is obtained from the component of the J-function  $J_{\mathcal{X}}$  along the unit class  $\mathbf{1}_0 \in H^0(X; \mathbb{Q}) \subseteq H_{\text{CR}}^0(\mathcal{X})$  by replacing the Novikov variable  $Q^d$  by  $t^{-K_X \cdot d}$  and setting  $z = 1$  and  $\gamma = t^{1-\text{age}(b_1)} x_1 \mathbf{1}_{b_1} + \cdots + t^{1-\text{age}(b_r)} x_r \mathbf{1}_{b_r}$ .

**Notation 2.3.** If  $d \in \text{Eff}(\mathcal{X})$ ,  $n \in \mathbb{N}$  and  $1 \leq i_1, \dots, i_n \leq r$ , then set

$$\text{GW}_{d, i_1, \dots, i_n} := \left\langle \mathbf{1}_{b_{i_1}}, \dots, \mathbf{1}_{b_{i_n}}, \phi_{\text{vol}} \psi^{\delta_{d, i_1, \dots, i_n} - 2} \right\rangle_{0, n+1, d} \in \mathbb{Q}.$$

**Proposition 2.4** ([OP]). *If  $\mathcal{X}$  is a Fano orbifold, then  $G_{\mathcal{X}} \in \mathbb{Q}[[x_1, \dots, x_r]][[t]]$  and the following formula holds:*

$$G_{\mathcal{X}}(x_1, \dots, x_r; t) = 1 + \sum_{\substack{d \in \text{Eff}(\mathcal{X}), \\ n \in \mathbb{N}, \\ 1 \leq i_1, \dots, i_n \leq r}} \frac{\text{GW}_{d, i_1, \dots, i_n}}{n!} x_{i_1} \cdots x_{i_n} t^{\delta_{d, i_1, \dots, i_n}}. \quad (2.3)$$

Moreover:

- (i) the coefficient of  $t$  in  $G_{\mathcal{X}}$  is zero;
- (ii) if  $f$  is the Fano index of  $X$ , then in the specialisation  $G_{\mathcal{X}}(0, \dots, 0; t)$  only powers of  $t^f$  appear, i.e.  $G_{\mathcal{X}}(0, \dots, 0; t) \in \mathbb{Q}[[t^f]]$ .

*Proof.* Notice

$$\left\langle \mathbf{1}_{b_{i_1}}, \dots, \mathbf{1}_{b_{i_n}}, \frac{\phi_{\text{vol}}}{1-\psi} \right\rangle_{0, n+1, d} = \sum_{k \in \mathbb{N}} \left\langle \mathbf{1}_{b_{i_1}}, \dots, \mathbf{1}_{b_{i_n}}, \phi_{\text{vol}} \psi^k \right\rangle_{0, n+1, d}.$$

If  $\left\langle \mathbf{1}_{b_{i_1}}, \dots, \mathbf{1}_{b_{i_n}}, \phi_{\text{vol}} \psi^k \right\rangle_{0, n+1, d}$  is non-zero, then  $\deg(\phi_{\text{vol}} \psi^k) = 2 \dim \mathcal{X} + 2k$  must be equal to the real virtual dimension of the corresponding component of  $\mathcal{X}_{0, n+1, d}$ ,

which is

$$2[-K_{\mathcal{X}} \cdot d + \dim \mathcal{X} - \text{age}(b_{i_1}) - \cdots - \text{age}(b_{i_n}) + (n+1) - 3].$$

Thus  $k = -K_{\mathcal{X}} \cdot d - \text{age}(b_{i_1}) - \cdots - \text{age}(b_{i_n}) + n - 2 = \delta_{d, i_1, \dots, i_n} - 2$  is uniquely determined by  $d, n$  and  $i_1, \dots, i_n \in \{1, \dots, r\}$ . This shows that the formula (2.3) holds.

We prove that  $\delta_{d, i_1, \dots, i_n}$  is an integer greater than 1 whenever  $d \in H_2(X, \mathbb{Z})$ ,  $n \in \mathbb{N}$ ,  $1 \leq i_1, \dots, i_n \leq r$  are such that  $\text{GW}_{d, i_1, \dots, i_n} \neq 0$ . In these circumstances there must exist a genus-zero  $(n+1)$ -pointed stable map

$$\begin{array}{ccc} \mathcal{C} & \xrightarrow{\varphi} & \mathcal{X} \\ \downarrow & & \downarrow \\ C & \xrightarrow{\bar{\varphi}} & X \end{array}$$

such that  $\bar{\varphi}_*[C] = d$  and the marking gerbes  $\Sigma_1, \dots, \Sigma_n, \Sigma_{n+1} \subseteq \mathcal{C}$  give geometric points in the components  $b_{i_1}, \dots, b_{i_n}, 0 \in \text{Box}(\mathcal{X})$  of  $\text{I}\mathcal{X}$ , respectively. By orbifold Riemann–Roch [AGV08, Theorem 7.2.1], we see that

$$\begin{aligned} \delta_{d, i_1, \dots, i_n} &= \deg_{\mathcal{C}} \varphi^* T_{\mathcal{X}} - \text{age}(b_{i_1}) - \cdots - \text{age}(b_{i_n}) + n \\ &= \chi(\mathcal{C}, \varphi^* T_{\mathcal{X}}) - \text{rk}(\varphi^* T_{\mathcal{X}}) \chi(\mathcal{C}, \mathcal{O}_{\mathcal{C}}) + n \end{aligned}$$

is an integer. Moreover, since Gromov–Witten invariants with negative gravitational descendants are zero by definition,  $\delta_{d, i_1, \dots, i_n} \geq 2$ . This proves (i).

Now we have to prove the finiteness of the sum (2.3). More specifically we have to prove that, for every integer  $\delta \geq 2$ , the coefficient

$$\sum_{\substack{d \in \text{Eff}(\mathcal{X}), \\ n \in \mathbb{N}, \\ 1 \leq i_1, \dots, i_n \leq r, \\ \text{s.t. } \delta_{d, i_1, \dots, i_n} = \delta}} \frac{\text{GW}_{d, i_1, \dots, i_n}}{n!} x_{i_1} \cdots x_{i_n} \quad (2.4)$$

of  $t^\delta$  is a polynomial in the variables  $x_1, \dots, x_r$ . This is a dimensional argument, as follows.

Let  $e$  be the least common multiple of the exponents of the automorphism groups of all geometric points of  $\mathcal{X}$ . By [AGV08, Lemma 2.1.2], the line bundle  $(\det(\Omega_{\mathcal{X}}^1)^\vee)^{\otimes e}$  on  $\mathcal{X}$  is the pull-back to  $\mathcal{X}$  of a line bundle  $H$  on  $X$ . Since  $\mathcal{X}$  is a Fano orbifold,  $H$  is an ample line bundle on  $X$ . In the divisor class group of  $X$  we have the equality  $H = -eK_X$ . As in [AV02], for every  $h, n \in \mathbb{N}$  let  $\mathcal{K}_{0, n}(\mathcal{X}, h)$  be the moduli stack of genus-zero  $n$ -marked stable maps  $\varphi: \mathcal{C} \rightarrow \mathcal{X}$  such that

$\deg_{\mathcal{C}} \bar{\varphi}^* H = h$ , where  $\bar{\varphi}: \mathcal{C} \rightarrow X$  is the coarse map.

Fix an integer  $\delta \geq 2$ . Let  $a = \max_{1 \leq i \leq r} \text{age}(b_i)$ . If  $d \in \text{Eff}(\mathcal{X})$ ,  $n \in \mathbb{N}$  and  $i_1, \dots, i_n \in \{1, \dots, r\}$  are such that  $\delta_{d, i_1, \dots, i_n} = \delta$ , then  $\delta \geq n(1-a)$  and  $\delta \geq -K_X \cdot d$ , so  $n \leq \delta/(1-a)$  and  $H \cdot d \leq e\delta$ . Hence the coefficient (2.4) of  $t^\delta$  involves some intersection products on some connected components of the proper stack

$$\prod_{\substack{n \leq \delta/(1-a), \\ h \leq e\delta}} \mathcal{K}_{0,n}(\mathcal{X}, h).$$

This shows that the sum (2.4) is a polynomial in the variables  $x_1, \dots, x_r$  with rational coefficients.

Now we prove (ii). Let  $\mathcal{L} \in \text{Pic}(\mathcal{X})$  be such that  $\omega_{\mathcal{X}}^\vee = \mathcal{L}^{\otimes f}$ . If the Gromov–Witten invariant  $\langle \phi_{\text{vol}} \psi^{-K_X \cdot d - 2} \rangle_{0,1,d}$  is non zero, then there exists a 1-pointed stable curve  $\varphi: \mathcal{C} \rightarrow \mathcal{X}$  such that  $\bar{\varphi}_*[C] = d$  and the marking gerbe  $\Sigma_1 \subseteq \mathcal{C}$  gives a geometric point in the trivial component of  $\mathcal{I}\mathcal{X}$ . By orbifold Riemann–Roch for  $-K_X = \omega_{\mathcal{X}}^\vee$  and  $\mathcal{L}$ ,

$$-K_X \cdot d = \deg_{\mathcal{C}} \varphi^* \omega_{\mathcal{X}}^\vee = f \cdot \deg_{\mathcal{C}} \varphi^* \mathcal{L} = f \cdot (\chi(\mathcal{C}, \varphi^* \mathcal{L}) - \chi(\mathcal{C}, \mathcal{O}_{\mathcal{C}}))$$

is divisible by  $f$ . This concludes the proof of (ii).  $\square$

**Remark 2.5.** Let  $\mathcal{X}$  be a Fano orbifold, let  $\mathbf{1}_{b_1}, \dots, \mathbf{1}_{b_r} \in \mathbf{H}_{\text{CR}}^\bullet(\mathcal{X})$  be the identity cohomology classes of the components of  $\mathcal{I}\mathcal{X}$  with age between 0 and 1, let  $e$  be the least common multiple of the exponents of the automorphism groups of all geometric points of  $\mathcal{X}$ , and let  $\phi_{\text{vol}}$  be the cohomology class of a point. We have  $\tilde{\mathbf{H}}_{\text{CR}}^{\leq 2}(\mathcal{X}) = \mathbb{Q}\mathbf{1}_{b_1} \oplus \dots \oplus \mathbb{Q}\mathbf{1}_{b_r}$ , where  $\tilde{\mathbf{H}}_{\text{CR}}^{\leq 2}(\mathcal{X})$  denotes the subspace of  $\mathbf{H}_{\text{CR}}^\bullet(\mathcal{X})$  generated by classes of degree in  $]0, 2[$ . For every  $n \in \mathbb{N}$  and  $d \in \text{Eff}(\mathcal{X})$ , consider the  $\mathbb{Q}[t^{1/e}]$ -valued multilinear symmetric  $n$ -form on  $\tilde{\mathbf{H}}_{\text{CR}}^{\leq 2}(\mathcal{X})$  defined, for any  $1 \leq i_1, \dots, i_n \leq r$ , by

$$(\mathbf{1}_{b_{i_1}}, \dots, \mathbf{1}_{b_{i_n}}) \mapsto \left\langle \mathbf{1}_{b_{i_1}}, \dots, \mathbf{1}_{b_{i_n}}, \frac{\phi_{\text{vol}}}{1-\psi} \right\rangle_{0, n+1, d} \prod_{j=1}^n t^{1-\text{age}(b_{i_j})};$$

this induces an element  $\Xi_{d,n} \in \text{Sym}^n \tilde{\mathbf{H}}_{\text{CR}}^{\leq 2}(\mathcal{X})^\vee \otimes_{\mathbb{Q}} \mathbb{Q}[t^{1/e}]$ . The quantum period of  $\mathcal{X}$  can be written as

$$G_{\mathcal{X}}(t) = 1 + \sum_{\substack{d \in \text{Eff}(\mathcal{X}), \\ n \in \mathbb{N}}} \frac{\Xi_{d,n}}{n!} t^{-K_X \cdot d}.$$

Proposition 2.4 shows that  $G_{\mathcal{X}} \in (\text{Sym}^\bullet \tilde{\mathbf{H}}_{\text{CR}}^{\leq 2}(\mathcal{X})^\vee)[[t]]$ . In this way, we can consider the quantum period and the regularised quantum period as families of power series  $\tilde{\mathbf{H}}_{\text{CR}}^{\leq 2}(\mathcal{X}) \rightarrow \mathbb{Q}[[t]]$ .

**Example 2.6.** If  $\mathcal{X}$  is a Fano orbifold such that its coarse moduli space  $X$  has canonical singularities, then there are no connected components of  $\mathrm{I}\mathcal{X}$  with positive age smaller than 1 by the Reid–Tai criterion [Kol13, Theorem 3.21]. Therefore, in this case,  $\tilde{\mathrm{H}}_{\mathrm{CR}}^{\leq 2}(\mathcal{X}) = 0$  and the quantum period of  $\mathcal{X}$  is

$$G_{\mathcal{X}}(t) = 1 + \sum_{\substack{d \in \mathrm{Eff}(\mathcal{X}) \\ \text{s.t. } -K_X \cdot d \geq 2}} \langle \phi_{\mathrm{vol}} \psi^{-K_X \cdot d - 2} \rangle_{0,1,d} t^{-K_X \cdot d}.$$

In particular, if  $X$  is a smooth Fano variety then this formula agrees with Definition 1.3, [CCG<sup>+</sup>14, Definition 4.2], and [CCGK16, §B].

**Example 2.7.** The well-formed orbifold associated to the affine surface  $\frac{1}{n}(1, q)$  is the quotient stack  $[\mathbb{A}^2/\mu_n]$ , where  $\mu_n$  acts linearly with weights  $(1, q)$ . The inertia stack of this stack has  $n$  connected components which are indexed by  $j = 0, \dots, n-1$ ; the 0th component is  $[\mathbb{A}^2/\mu_n]$  itself and has age 0; the  $j$ th component (as  $1 \leq j < n$ ) is  $\mathrm{B}\mu_n$  and has age  $\{\frac{j}{n}\} + \{\frac{jq}{n}\}$ .

Let  $X$  be a del Pezzo surface with  $r$  singular points which are cyclic quotient singularities of type  $\frac{1}{n_i}(1, q_i)$  as  $i = 1, \dots, r$ , and let  $\mathcal{X}$  be the Fano orbifold associated to  $X$ . The inertia stack  $\mathrm{I}\mathcal{X}$  has  $1 + \sum_{i=1}^r (n_i - 1)$  connected components. Then the quantum period of  $\mathcal{X}$  is a family of power series parametrised by

$$\tilde{\mathrm{H}}_{\mathrm{CR}}^{\leq 2}(\mathcal{X}) = \bigoplus_{i=1}^r \bigoplus_{\substack{1 \leq j < n_i \text{ s.t.} \\ \{\frac{j}{n_i}\} + \{\frac{jq_i}{n_i}\} < 1}} \mathbb{Q} \mathbf{1}_{i,j}.$$

**Example 2.8.** Let  $X$  be a del Pezzo surface with  $r$  singular points of type  $\frac{1}{3}(1, 1)$  and let  $\mathcal{X}$  be the Fano orbifold associated to  $X$ . Then, the inertia stack  $\mathrm{I}\mathcal{X}$  has  $1 + 2r$  connected components: the trivial connected component of age 0 (which is isomorphic to  $\mathcal{X}$ ),  $r$  connected components of age  $2/3$  (which are isomorphic to  $\mathrm{B}\mu_3$ ),  $r$  connected components of age  $4/3$  (which are isomorphic to  $\mathrm{B}\mu_3$ ). For  $i = 1, \dots, r$ , let  $\mathbf{1}_i$  be the identity cohomology class of the  $i$ th connected component of age  $2/3$ . Then the quantum period of  $\mathcal{X}$  is:

$$G_{\mathcal{X}}(x_1, \dots, x_r; t) = 1 + \sum_{\substack{d \in \mathrm{Eff}(\mathcal{X}), \\ n \in \mathbb{N}, \\ 1 \leq i_1, \dots, i_n \leq r}} \langle \mathbf{1}_{i_1}, \dots, \mathbf{1}_{i_n}, \phi_{\mathrm{vol}} \psi^{-K_X \cdot d + \frac{n}{3} - 2} \rangle_{0, n+1, d} \frac{x_{i_1} \cdots x_{i_n}}{n!} t^{-K_X \cdot d + \frac{n}{3}}.$$

### 2.1.4. Quantum periods of del Pezzo surfaces with $\frac{1}{3}(1, 1)$ singularities

Corti and Heuberger [CH17] have proved that there are 29  $\mathbb{Q}$ -Gorenstein deformation families of del Pezzo surfaces with  $\frac{1}{3}(1, 1)$  singularities. In collaboration with Alessandro Oneto [OP] we have computed some specializations of the quantum period for 26 out of these 29 families.

More specifically, out of these 29 families, three have Fano index greater than 1: the weighted projective plane  $\mathbb{P}(1, 1, 3)$  and two surfaces denoted by  $B_{1,16/3}$  and  $B_{2,8/3}$ ; the remaining 26 families have Fano index equal to 1 and they are denoted by  $X_{k,d}$ , where  $k$  is the number of singular points and  $d = K_X^2$  is the degree. For many of these surfaces, Corti and Heuberger [CH17] exhibit explicit models, which are essential for our computations of the quantum periods. The methods of our computations are the following.

- 6 surfaces are toric. Using the mirror theorem for toric stacks (see §2.3.2) we compute the full quantum periods. An example is given in §2.3.3.
- 19 surfaces are complete intersections in toric orbifolds. Using a conjectural generalisation of the Quantum Lefschetz theorem (see §2.4.1), we compute the restriction of the quantum period to a non-empty affine subspace of  $\tilde{H}_{\text{CR}}^{\leq 2}(\mathcal{X})$ . In §2.4.3 and §2.4.4 we give two examples of these computations.
- The surface  $X_{1,7/3}$  is described as a complete intersection inside a weighted Grassmannian. In §2.5.2, combining conjectural generalisations of the Quantum Lefschetz theorem (see §2.4.1) and the Abelian/non-Abelian Correspondence (see §2.5.1), we compute a restriction of the quantum period to a non-empty affine subspace of  $\tilde{H}_{\text{CR}}^{\leq 2}(\mathcal{X})$ .
- For the surfaces  $X_{5,2/3}$ ,  $X_{5,5/3}$ ,  $X_{6,1}$ , since we do not know any useful model for computations in Gromov–Witten theory, we have not been able to compute any restriction of the quantum period.

Although our computations rest on conjectural generalisations of the Quantum Lefschetz theorem and of the Abelian/non-Abelian Correspondence, we are confident that the results of our computations are correct because, even though partial, they match perfectly with the framework of Mirror Symmetry for orbifold del Pezzo surfaces, as formulated in [ACC<sup>+</sup>16] and in §2.2 below.

Our complete results are reported in [OP] and will not appear here; as we said, we only include four examples in §2.3.3, §2.4.3, §2.4.4, and §2.5.2. Our computa-

tions rely on the use of the computer; indeed, we have implemented the machinery described in §2.3.1, §2.3.2, §2.4.2 in the language of computer algebra software MAGMA [BCP97].

## 2.2. Mirror Symmetry for orbifold del Pezzo surfaces II

Here we continue the general discussion of §1.6. The second conjecture of our joint work with Akhtar, Coates, Corti, Heuberger, Kasprzyk, Oneto, Prince, Tveiten [ACC<sup>+</sup>16] (see Conjecture 2.12 below) predicts that the regularised quantum period of an orbifold del Pezzo surface  $X$  with  $\mathbb{Q}$ -Gorenstein rigid cyclic singularities coincides with the classical period of a certain family of ‘special’ Laurent polynomials supported on the polygon corresponding to some toric  $\mathbb{Q}$ -Gorenstein degeneration of  $X$ .

These ‘special’ Laurent polynomials are called maximally mutable and are those that can follow algebraically (see Definition 1.9) every combinatorial mutation (see Definition 1.15) of their Newton polytope. In other words, maximally mutable Laurent polynomials of a Fano polygon  $P$  are the Laurent polynomials  $f \in \mathbb{Q}[N]$  such that the Newton polygon of  $f$  is  $P$  and they stay Laurent after every mutation of  $P$  and the corresponding operation on  $f$ . This notion is due to Kasprzyk and Tveiten [KT] and the precise definition is below.

**Definition 2.9** ([ACC<sup>+</sup>16, KT]). Let  $P$  be a Fano polygon in a rank 2 lattice  $N$ . A Laurent polynomial  $f \in \mathbb{Q}[N]$  is called a *maximally mutable Laurent polynomial of  $P$*  if:

- (i) the Newton polygon of  $f$  is  $P$ ;
- (ii) the coefficient of the monomial  $1 = \chi^0$  is 0;
- (iii) whenever

$$P = P_0 \rightarrow P_1 \rightarrow \cdots \rightarrow P_n$$

is a sequence of combinatorial mutations (see Definition 1.15) with respect to vectors  $w_i \in M$  and factors  $F_i = \text{conv}\langle 0, u_i \rangle \subseteq N_{\mathbb{R}}$ , with  $u_i \in N$  primitive, as  $i = 1, \dots, n$ , we have that the rational function  $f_1, \dots, f_n \in \mathbb{C}(N)$  defined recursively via algebraic mutations (see Definition 1.9) as  $f_0 := f$ ,  $f_i := \text{mut}_{w_i, 1+\chi^{u_i}}(f_{i-1})$  are all Laurent polynomials.

Let  $\mathbf{L}(P)$  be the  $\mathbb{Q}$ -vector space of maximally mutable Laurent polynomials of  $P$ .



There is also a restriction on the boundary coefficients we have to require.

**Definition 2.10** ([ACC<sup>+</sup>16,KT]). Let  $P$  be a Fano polygon in a rank 2 lattice  $N$ . Let  $f \in \mathbb{Q}[N]$  be a Laurent polynomial such that  $\text{Newt } f = P$ . We say that  $f$  has *T-binomial coefficients* if the following condition is satisfied.

- Let  $E$  be an edge of  $P$  and let  $\frac{1}{n}(1, q)$  be the corresponding singularity<sup>3</sup> of the toric surface  $X_P$ ; set  $w = \gcd(n, q + 1)$ ,  $n = wr$ ,  $q + 1 = wa$ ,  $w = mr + w_0$  with  $0 \leq w_0 < r$ . Then the successive coefficients of  $f$  along the edge  $E$  are the successive coefficients of the powers of the variable  $x$  in

$$\begin{cases} (1+x)^{mr} & \text{if } w_0 = 0, \\ (1+x)^{mr}(1+x)^{w_0} & \text{if } w_0 \neq 0. \end{cases}$$

We denote by  $\mathbf{L}^T(P)$  the affine space of maximally mutable Laurent polynomials of  $P$  with T-binomial coefficients.

Consider the following setup.

**Setup 2.11.** Let  $P$  be a Fano polygon inside a rank 2 lattice. Let  $X_P$  is the toric del Pezzo surface corresponding to the spanning fan of  $P$ . Let  $X$  be a generic  $\mathbb{Q}$ -Gorenstein deformation of  $X_P$ , and  $\mathcal{X}$  be the unique well-formed orbifold such that its coarse moduli space is  $X$ .

In the setup above, one may consider the space of maximally mutable Laurent polynomials of  $P$  with T-binomial coefficients and consider the corresponding family of classical periods (see Definition 1.4): this is a family of power series parametrised by  $\mathbf{L}^T(P)$ . On the other hand, we may consider the quantum period of the Fano orbifold  $\mathcal{X}$  (see Definition 2.2), which is a family of power series parametrised by  $\widetilde{\mathbf{H}}_{\text{CR}}^{\leq 2}(\mathcal{X})$ . The second conjecture of [ACC<sup>+</sup>16] says that these two families of power series are the same up to an affine transformation.

**Conjecture 2.12** (Conjecture B in [ACC<sup>+</sup>16]). *Let  $P, X, \mathcal{X}$  be as in Setup 2.11. Then there exists an affine-linear isomorphism  $\Phi: \mathbf{L}^T(P) \rightarrow \widetilde{\mathbf{H}}_{\text{CR}}^{\leq 2}(\mathcal{X})$  such that*

$$\forall f \in \mathbf{L}^T(P), \quad \widehat{G}_{\mathcal{X}}(\Phi(f); t) = \pi_f(t),$$

where  $\widehat{G}_{\mathcal{X}}$  is the regularised quantum period of  $\mathcal{X}$  and  $\pi_f$  is the classic period of  $f$ .

---

<sup>3</sup>Here we assume  $n, q \in \mathbb{N}$ ,  $1 \leq q \leq n$ , and  $\gcd(n, q) = 1$ . Thus, if  $n = 1$  then this is a smooth point of  $X_P$ .

The case in which  $X$  is a smooth del Pezzo surface (hence  $\mathcal{X} = X$ ), is proven in [CCGK16]. An example is Example 1.7 with  $n = 2$ .

Corti and Heuberger [CH17] have proved that, out of the 29 del Pezzo surfaces with  $\frac{1}{3}(1, 1)$  points, only 26 surfaces admit a  $\mathbb{Q}$ -Gorenstein degeneration to a toric surface. Indeed, the surfaces  $X_{4,1/3}$ ,  $X_{5,2/3}$  and  $X_{6,1}$  do not have any  $\mathbb{Q}$ -Gorenstein degeneration to a toric surface.

The Fano polygons  $P$  such that the corresponding surface  $X$ , according to Setup 2.11, has only  $\frac{1}{3}(1, 1)$  points have been classified up to mutation by Kasprzyk, Nill and Prince [KNP]. There are 26 mutation equivalence classes of such polygons and they correspond to the del Pezzo surfaces mentioned above. The spaces  $\mathbf{L}^T(P)$ , for such polygons  $P$ , have been computed by Kasprzyk and Tveiten [KT].

Combining these results with our calculations, in collaboration with Oneto [OP], which are summarised in §2.1.4, yields the following.

**Theorem 2.13** ([OP]). *Let  $P$ ,  $X$  and  $\mathcal{X}$  be as in Setup 2.11. Suppose that  $X$  has only  $\frac{1}{3}(1, 1)$  singularities and is not  $X_{5,5/3}$ .*

*If natural generalisations of the Quantum Lefschetz theorem (Conjecture 2.18) and of the Abelian/non-Abelian Correspondence (Conjecture 2.23) hold, then there exist a non-empty affine subspace  $W \subseteq \mathbf{L}^T(P)$  and an injective affine-linear map  $\Phi: W \rightarrow \widetilde{\mathbf{H}}_{\mathbb{C}\mathbb{R}}^{<2}(\mathcal{X})$  such that*

$$\forall f \in W, \quad \widehat{G}_{\mathcal{X}}(\Phi(f); t) = \pi_f(t).$$

## 2.3. Toric stacks

### 2.3.1. Stacky fans and extended stacky fans

Here we briefly recall the theory of toric stacks [BCS05, FMN10] and the combinatorial machinery developed in [CCIT15], which will allow us to produce a point of the Givental cone for a toric stack. We will present the case of toric well-formed orbifolds only. Let  $X$  be a simplicial toric variety which is proper over  $\mathbb{C}$ : as in [Ful93]  $X$  comes from a finitely generated free abelian group  $N$  and a complete *simplicial* fan  $\Sigma$  in  $N_{\mathbb{R}}$ . Let  $\rho: \mathbb{Z}^n \rightarrow N$  be the linear map which maps the  $i$ th standard basis element of  $\mathbb{Z}^n$  to the primitive generator  $\rho_i$  of the  $i$ th ray of the fan  $\Sigma$ . So  $n$  is the number of rays of  $\Sigma$ . Let  $\mathbb{L}$  be the kernel of  $\rho$ . The exact sequence

$$0 \longrightarrow \mathbb{L} \longrightarrow \mathbb{Z}^n \xrightarrow{\rho} N \tag{2.5}$$

is called the *fan sequence*. Set  $M := \text{Hom}_{\mathbb{Z}}(N, \mathbb{Z})$ . Since the coker  $\rho$  is finite, the dual map  $\rho^*: M \rightarrow \mathbb{Z}^{*n}$ , which is obtained from  $\rho$  by applying  $\text{Hom}_{\mathbb{Z}}(-, \mathbb{Z})$ , is injective. The cokernel of  $\rho^*$  is denoted by  $\mathbb{L}^\vee$  and is called the *Gale dual* of  $\rho$ . We get a short exact sequence, which is called the *divisor sequence*:

$$0 \longrightarrow M \xrightarrow{\rho^*} \mathbb{Z}^{*n} \xrightarrow{D} \mathbb{L}^\vee \longrightarrow 0. \quad (2.6)$$

So  $\mathbb{L}^\vee$  is an extension of  $\mathbb{L}^* = \text{Hom}_{\mathbb{Z}}(\mathbb{L}, \mathbb{Z})$  by a finite group which is isomorphic to  $\text{coker } \rho$ . In particular, if  $\rho$  is surjective, then  $\mathbb{L}^\vee = \mathbb{L}^*$ . The group  $\mathbb{Z}^{*n}$  in (2.6) is identified with the group of torus-invariant Weil divisors of  $X$  and the group  $\mathbb{L}^\vee$  is canonically isomorphic to the divisor class group  $\text{Cl}(X)$ : the image  $D_i \in \mathbb{L}^\vee$  of the  $i$ th standard basis element of  $\mathbb{Z}^{*n}$  is the class of the  $i$ th toric divisor of  $X$ . The anticanonical class of  $X$  is given by  $-K_X = D_1 + \cdots + D_n \in \mathbb{L}^\vee$ . We have  $N^1(X) = \mathbb{L}^\vee \otimes_{\mathbb{Z}} \mathbb{R}$  and the nef cone of  $X$  is

$$\text{Nef}(X) = \bigcap_{\sigma \in \Sigma} \text{cone} \langle D_i \mid i \notin \sigma \rangle \subseteq \mathbb{L}^\vee \otimes_{\mathbb{Z}} \mathbb{R} = N^1(X). \quad (2.7)$$

Moreover,  $A_1(X)_{\mathbb{Q}} = N_1(X)_{\mathbb{Q}} \simeq \mathbb{L} \otimes_{\mathbb{Z}} \mathbb{Q}$ . The bilinear form  $\mathbb{L}^\vee \times \mathbb{L} \rightarrow \mathbb{Z}$ , which is induced by the duality pairing of  $\mathbb{Z}^n$ , induces the pairing  $N^1(X) \times N_1(X) \rightarrow \mathbb{R}$  between numerical classes of divisors and numerical classes of curve cycles. The Mori cone  $\text{NE}(X)$  is the dual cone of  $\text{Nef}(X)$  in  $\mathbb{L} \otimes_{\mathbb{Z}} \mathbb{R}$ .

Applying the functor  $\text{Hom}_{\mathbb{Z}}(-, \mathbb{C}^\times)$  to (2.6), we get a homomorphism of algebraic groups from  $\mathbb{G} := \text{Hom}(\mathbb{L}^\vee, \mathbb{C}^\times)$  to the torus  $(\mathbb{C}^\times)^n$ . Since  $(\mathbb{C}^\times)^n$  acts diagonally on  $\mathbb{A}_{\mathbb{C}}^n$ , there is an induced linear action of  $\mathbb{G}$  on  $\mathbb{A}_{\mathbb{C}}^n$ . Let  $x_1, \dots, x_n$  be the standard coordinates on  $\mathbb{A}_{\mathbb{C}}^n$ . Consider the ideal  $\text{Irr}_{\Sigma}$  of  $\mathbb{C}[x_1, \dots, x_n]$  generated by the monomials  $\prod_{i: \rho_i \notin \sigma} x_i$  as  $\sigma \in \Sigma$  and the quasi-affine variety  $U_{\Sigma} = \mathbb{A}_{\mathbb{C}}^n \setminus V(\text{Irr}_{\Sigma})$ . The quotient stack  $\mathcal{X} := [U_{\Sigma}/\mathbb{G}]$  is called the *toric stack* associated to the triple  $(N, \Sigma, \rho)$ , which is called a *stacky fan*. By [BCS05, FMN10],  $\mathcal{X}$  is a proper well-formed orbifold and its coarse moduli space is  $X$ . By [BCS05, Proposition 4.7], the connected components of the inertia stack  $\text{I}\mathcal{X}$  are indexed by the finite set

$$\text{Box}(\Sigma) := N \cap \bigcup_{\sigma \in \Sigma} \left\{ \sum_{i: \rho_i \in \sigma} a_i \rho_i \mid 0 \leq a_i < 1 \right\}.$$

The element  $b = \sum_{\rho_i \in \sigma} a_i \rho_i \in \text{Box}(\Sigma)$ , for some  $\sigma \in \Sigma$  and  $0 < a_i < 1$ , corresponds to the subvariety of  $X$  defined by the homogeneous equations  $x_i = 0$  for  $\rho_i \in \sigma$ . Its age is  $\sum a_i$ .

Now, we describe the formalism of extended stacky fans according to [Jia08].

We choose a (possibly empty) finite set  $S$  with a map  $S \rightarrow N$ . We label the set  $S$  by  $\{1, \dots, m\}$  and write  $s_j \in N$  for the image of the  $j$ th element of  $S$ . Following [Jia08, Definition 2.1], we consider the  $S$ -extended stacky fan  $(N, \Sigma, \rho^S)$ , where  $\rho^S: \mathbb{Z}^{n+m} \rightarrow N$  is defined by

$$\rho^S(e_i) = \begin{cases} \rho_i & i = 1, \dots, n \\ s_{i-n} & i = n+1, \dots, n+m \end{cases} \quad (2.8)$$

and  $e_i$  is the  $i$ th standard basis vector for  $\mathbb{Z}^{n+m}$ . This gives the *extended fan sequence*

$$0 \longrightarrow \mathbb{L}^S \longrightarrow \mathbb{Z}^{n+m} \xrightarrow{\rho^S} N \quad (2.9)$$

and by Gale duality the *extended divisor sequence*

$$0 \longrightarrow M \longrightarrow \mathbb{Z}^{n+m} \xrightarrow{D^S} \mathbb{L}^{S^\vee} \longrightarrow 0. \quad (2.10)$$

The inclusion  $\mathbb{Z}^n \rightarrow \mathbb{Z}^{n+m}$  of the first  $n$  factors induces an exact sequence

$$0 \longrightarrow \mathbb{L} \longrightarrow \mathbb{L}^S \longrightarrow \mathbb{Z}^m,$$

which splits over  $\mathbb{Q}$  via the map  $\mathbb{Q}^m \rightarrow \mathbb{L}^S \otimes_{\mathbb{Z}} \mathbb{Q}$  that sends the  $j$ th standard basis vector to

$$e_{j+n} - \sum_{i: \rho_i \in \sigma(j)} s_j^i e_i \in \mathbb{L}^S \otimes_{\mathbb{Z}} \mathbb{Q} \subseteq \mathbb{Q}^{n+m}$$

where  $\sigma(j) \in \Sigma$  is the minimal cone containing  $s_j$  and the positive numbers  $s_j^i$  are determined by  $\sum_{i: \rho_i \in \sigma(j)} s_j^i \rho_i = s_j$ . Thus we obtain an isomorphism:

$$\mathbb{L}^S \otimes_{\mathbb{Z}} \mathbb{Q} \simeq (\mathbb{L} \otimes_{\mathbb{Z}} \mathbb{Q}) \oplus \mathbb{Q}^m. \quad (2.11)$$

Therefore, an element  $\lambda \in \mathbb{L}^S \otimes_{\mathbb{Z}} \mathbb{Q} \subseteq \mathbb{Q}^{m+n}$  correspond to the pair  $(d, k)$ , where

$$d = \sum_{i=1}^n \left( \lambda_i + \sum_{j=1}^m s_j^i \lambda_{n+j} \right) e_i \in \mathbb{L} \otimes_{\mathbb{Z}} \mathbb{Q} \subseteq \mathbb{Q}^n$$

$$k = \sum_{j=1}^m \lambda_{n+j} e_j \in \mathbb{Q}^m.$$

The *extended Mori cone* is the subset of  $\mathbb{L}^S \otimes_{\mathbb{Z}} \mathbb{R}$  given by  $\text{NE}^S(\mathcal{X}) = \text{NE}(\mathcal{X}) \times (\mathbb{R}_{\geq 0})^m$  via the isomorphism (2.11). The extended Mori cone can be thought of as the cone spanned by the ‘extended degrees’ of certain stable maps  $f: \mathcal{C} \rightarrow \mathcal{X}$ : see

[CCIT15, §4] for details. The dual of  $\text{NE}^S(\mathcal{X})$  in  $\mathbb{L}^{Sv} \otimes_{\mathbb{Z}} \mathbb{R}$  is called the *extended nef cone* of  $\mathcal{X}$  and is denoted by  $\text{Nef}^S(\mathcal{X})$ . There is an equality of cones in  $\mathbb{L}^{Sv} \otimes_{\mathbb{Z}} \mathbb{R}$

$$\text{Nef}^S(\mathcal{X}) = \bigcap_{\sigma \in \Sigma} \text{cone} \langle \{D_i^S \mid 1 \leq i \leq n, \rho_i \notin \sigma\} \cup \{D_{n+j}^S \mid 1 \leq j \leq m\} \rangle, \quad (2.12)$$

where  $D_i^S \in \mathbb{L}^{Sv} \otimes_{\mathbb{Z}} \mathbb{R}$  is the image of the  $i$ th element of the standard basis of  $\mathbb{Z}^{n+m}$  via the map  $D^S$ .

For a cone  $\sigma \in \Sigma$ , denote by  $\Lambda_{\sigma}^S \subseteq \mathbb{L}^S \otimes_{\mathbb{Z}} \mathbb{Q}$  the subset consisting of elements

$$\lambda = \sum_{i=1}^{n+m} \lambda_i e_i \in \mathbb{L}^S \otimes_{\mathbb{Z}} \mathbb{Q} \subseteq \mathbb{Q}^{n+m}$$

such that  $\lambda_{n+j} \in \mathbb{Z}$ ,  $1 \leq j \leq m$ , and  $\lambda_i \in \mathbb{Z}$  whenever  $\rho_i \notin \sigma$  and  $i \leq n$ . Set  $\Lambda^S := \bigcup_{\sigma \in \Sigma} \Lambda_{\sigma}^S$  and  $\Lambda E^S := \Lambda^S \cap \text{NE}^S$ . The *reduction function* is  $v^S: \Lambda^S \rightarrow \text{Box}(\Sigma)$  defined by

$$v^S(\lambda) = \sum_{i=1}^n [\lambda_i] \rho_i + \sum_{j=1}^m [\lambda_{n+j}] s_j = \sum_{i=1}^n \langle -\lambda_i \rangle \rho_i.$$

If  $\lambda \in \Lambda_{\sigma}^S$ , then  $v^S(\lambda) \in \text{Box}(\Sigma) \cap \sigma$ .

### 2.3.2. The mirror theorem for toric stacks

By using the combinatorial objects associated to extended stacky fans (as in §2.3.1), we give the definition of I-function for a toric stack. Let  $\mathcal{X}$  be a toric orbifold as above and let  $(N, \Sigma, \rho^S)$  be an  $S$ -extended stacky fan defining  $\mathcal{X}$ . Then the *S-extended I-function* [CCIT15] of  $\mathcal{X}$  is:

$$I^S(\tau, \xi, z) := z e^{\sum_{i=1}^n u_i \tau_i / z} \sum_{\lambda \in \Lambda E^S} \tilde{Q}^{\lambda} e^{\lambda \tau} \left( \prod_{i=1}^{n+m} \frac{\prod_{\substack{a \leq 0 \\ \langle a \rangle = \langle \lambda_i \rangle}} (u_i + az)}{\prod_{\substack{a \leq \lambda_i \\ \langle a \rangle = \langle \lambda_i \rangle}} (u_i + az)} \right) \mathbf{1}_{v^S(\lambda)}, \quad (2.13)$$

where:

- $\tau = (\tau_1, \dots, \tau_n)$  and  $\xi = (\xi_1, \dots, \xi_m)$  are formal variables;
- for  $1 \leq i \leq n$ ,  $u_i \in H^2(\mathcal{X}; \mathbb{Q})$  is the first Chern class of the line bundle corresponding to the  $i$ th toric divisor  $D_i$ ;
- for  $n+1 \leq i \leq n+m$ ,  $u_i$  is defined to be zero;

- for  $\lambda \in \Lambda E^S$ ,  $\tilde{Q}^\lambda := Q^d \xi_1^{k_1} \cdots \xi_m^{k_m} \in \Lambda[[\xi_1, \dots, \xi_m]]$ , where  $d \in \mathbb{L} \otimes_{\mathbb{Z}} \mathbb{Q}$  and  $k \in \mathbb{N}^m$  are such that  $\lambda$  corresponds to  $(d, k)$  via (2.11) and  $Q^d$  denotes the representative of  $d \in \text{Eff}(\mathcal{X})$  in the Novikov ring  $\Lambda$ ;
- for  $\lambda \in \Lambda E^S$ ,  $e^{\lambda\tau} := \prod_{i=1}^n e^{(u_i \cdot d)\tau_i}$ ;
- for  $\lambda \in \Lambda E^S$ ,  $\mathbf{1}_{v^S(\lambda)} \in H^0(\mathcal{X}_{v^S(\lambda)}; \mathbb{Q}) \subseteq H_{\text{CR}}^{2\text{age}(v^S(\lambda))}(\mathcal{X})$  is the identity class supported on the component of inertia associated to  $v^S(\lambda) \in \text{Box}(\Sigma)$ .

The I-function  $I^S(\tau, \xi, z)$  is a formal power series in  $Q, \xi, \tau$  with coefficients in  $H_{\text{CR}}^\bullet(\mathcal{X}) \otimes_{\mathbb{Q}} \mathbb{C}((z^{-1}))$ .

**Theorem 2.14** (Mirror theorem for toric stacks [CCIT15]). *Let  $X$  be a projective simplicial toric variety, associated to the fan  $\Sigma$  in the lattice  $N$ , and let  $\mathcal{X}$  be the corresponding toric well-formed orbifold constructed above. Let  $S$  be a finite set equipped with a map to  $N$ . Then the  $S$ -extended I-function  $I^S(\tau, \xi, -z)$  lies in the Givental cone  $\mathcal{L}_{\mathcal{X}}$  for all values of the parameters  $\tau$  and  $\xi$ .*

The mirror theorem relates the combinatorics of toric geometry (namely the I-function) with Gromov–Witten theory (namely the Givental cone  $\mathcal{L}_{\mathcal{X}}$ ). In §2.3.3 we will show an example in which the mirror theorem is applied to compute the quantum period of a toric Fano orbifold.

**Remark 2.15.** The formula (2.13) for the extended I-function is given in [CCIT15]. In our calculations we will use a slightly different version, which provides the same amount of information in Theorem 2.14. Let  $p_1, \dots, p_\ell$  be an integral basis of  $H^2(\mathcal{X}; \mathbb{Q})$ . Then we use the formal variables  $\tau = (\tau_1, \dots, \tau_\ell)$  and the exponentials appearing in (2.13) are replaced by  $e^{\sum_{i=1}^{\ell} p_i \tau_i / z}$  and by  $e^{\lambda\tau} := \prod_{i=1}^{\ell} e^{(p_i \cdot d)\tau_i}$ .

### 2.3.3. A toric example: the blow-up of $\mathbb{P}(1, 1, 3)$ at one point.

Let  $P$  be the Fano polygon in  $N = \mathbb{Z}^2$  whose vertices are the columns of the matrix

$$\rho = \begin{pmatrix} 1 & 0 & -1 & -2 \\ -1 & 1 & 2 & 1 \end{pmatrix}.$$

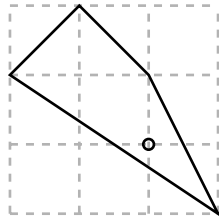

Let  $\Sigma$  be the spanning fan of  $P$ . Let  $X$  be the toric variety associated to  $\Sigma$  and let  $\mathcal{X}$  be the corresponding toric orbifold.

The rays  $\rho_1, \rho_3$  and  $\rho_4$  would define  $\mathbb{P}(1, 1, 3)$  and the toric divisor corresponding to  $\rho_2$  is obtained after blowing-up  $\mathbb{P}(1, 1, 3)$  at one smooth torus-invariant point. So  $X$  is the blow-up of  $\mathbb{P}(1, 1, 3)$  at a smooth point. Its degree is  $22/3$  and it has a singular point, so it is denoted by  $X_{1,22/3}$  in [CH17].

A basis of  $\mathbb{L} = \ker(\rho: \mathbb{Z}^4 \rightarrow N)$  is given by the rows of the matrix

$$D = \begin{pmatrix} 3 & 0 & 1 & 1 \\ -1 & 1 & -1 & 0 \end{pmatrix}.$$

We use this basis to identify  $\mathbb{L}$  with  $\mathbb{Z}^2$ . The fan sequence (2.5) is

$$0 \longrightarrow \mathbb{L} \simeq \mathbb{Z}^2 \xrightarrow{tD} \mathbb{Z}^4 \xrightarrow{\rho} N = \mathbb{Z}^2 \longrightarrow 0$$

and the divisor sequence (2.6) is

$$0 \longrightarrow M = \mathbb{Z}^2 \xrightarrow{t\rho} \mathbb{Z}^4 \xrightarrow{D} \mathbb{L}^\vee \simeq \mathbb{Z}^2 \longrightarrow 0,$$

where  $\mathbb{L}^\vee$  is identified with  $\mathbb{Z}^2$  via the dual basis  $\{p_1, p_2\}$  of the chosen basis of  $\mathbb{L}$ . The anticanonical class of  $X$  is the sum of the divisor classes of the irreducible torus-invariant divisors:  $-K_X = 5p_1 - p_2$  in  $\text{Cl}(X)$ .

The irrelevant ideal is  $\text{Irr}_\Sigma = (x_3x_4, x_1x_4, x_1x_2, x_2x_3)$ . Set  $U_\Sigma = \mathbb{A}_{\mathbb{C}}^4 \setminus V(\text{Irr}_\Sigma)$ . Consider the linear action of  $\mathbb{G}_m^2$  on  $\mathbb{A}_{\mathbb{C}}^4$  induced by the group homomorphism  $\mathbb{G}_m^2 \rightarrow \mathbb{G}_m^4$  defined dually by  $D$ . The toric variety  $X$  is the geometric quotient of  $U_\Sigma$  with respect to this action, i.e.  $X = U_\Sigma/\mathbb{G}_m^2$ , and  $\mathcal{X}$  is the quotient stack  $[U_\Sigma/\mathbb{G}_m^2]$ . Using (2.7) we get that the nef cone of  $X$  is  $\text{Nef}(X) = \text{cone}\langle 3p_1 - p_2, p_1 \rangle \subseteq \mathbb{L}^\vee \otimes_{\mathbb{Z}} \mathbb{R}$ .

Now we analyse the Chen–Ruan cohomology of  $\mathcal{X}$ . The inertia stack  $\text{I}\mathcal{X}$  has three connected components: the component with age 0, which is isomorphic to  $\mathcal{X}$ , and two components isomorphic to  $\text{B}\mu_3$  corresponding to the non-trivial stabilizers of the singular point, which have ages  $\frac{2}{3}$  and  $\frac{4}{3}$ . A basis of the rational cohomology of  $X$  is given by  $\{\mathbf{1}_0, p_1, p_2, \text{pt}\}$ . Therefore, if we denote by  $\mathbf{1}_{2/3}$  and  $\mathbf{1}_{4/3}$  the cohomology classes of the non-trivial components of  $\text{I}\mathcal{X}$ , we have that  $\{\mathbf{1}_0, \mathbf{1}_{2/3}, p_1, p_2, \mathbf{1}_{4/3}, \text{pt}\}$  is a basis of  $\text{H}_{\text{CR}}^\bullet(\mathcal{X})$ . The set of the connected components of  $\text{I}\mathcal{X}$  is in a canonical one-to-one correspondence with  $\text{Box}(\Sigma) = \{(0, 0), (-1, 1), (-2, 2)\}$ ; the zero vector corresponds to the trivial component of  $\text{I}\mathcal{X}$ , whereas the vectors  $(-1, 1)$  and  $(-2, 2)$  correspond to the non-trivial components of  $\text{I}\mathcal{X}$  with ages  $\frac{2}{3}$  and  $\frac{4}{3}$ , respectively.

Since we are interested in the part of  $\text{H}_{\text{CR}}^\bullet(\mathcal{X})$  of degree smaller than 2, we

‘extend’ with the vector  $(-1, 1)$ . In other words, we consider the map  $S = \{1\} \rightarrow N$  with  $s_1 = (-1, 1) \in N$  and the corresponding extended stacky fan, which is the one with extended ray map (2.8)

$$\rho^S = \begin{pmatrix} 1 & 0 & -1 & -2 & -1 \\ -1 & 1 & 2 & 1 & 1 \end{pmatrix}.$$

A basis of  $\mathbb{L}^S = \ker(\rho^S: \mathbb{Z}^5 \rightarrow \mathbb{Z}^2 = N)$  is given by the rows of the matrix

$$D^S = \begin{pmatrix} 3 & 0 & 1 & 1 & 0 \\ -1 & 1 & -1 & 0 & 0 \\ 1 & 0 & 0 & 0 & 1 \end{pmatrix}.$$

We use this basis to identify  $\mathbb{L}^S$  with  $\mathbb{Z}^3$  and we call  $l_1, l_2, k$  the coordinates with respect to this basis. The extended fan sequence (2.9) is

$$0 \longrightarrow \mathbb{L}^S \simeq \mathbb{Z}^3 \longrightarrow \mathbb{Z}^5 \xrightarrow{\rho^S} N = \mathbb{Z}^2 \longrightarrow 0$$

and the extended divisor sequence (2.10) is

$$0 \longrightarrow M = \mathbb{Z}^2 \longrightarrow \mathbb{Z}^5 \xrightarrow{D^S} \mathbb{L}^{S\vee} \simeq \mathbb{Z}^3 \longrightarrow 0,$$

where the inclusion  $\mathbb{L}^S \otimes_{\mathbb{Z}} \mathbb{R} \hookrightarrow \mathbb{R}^5$  is given by  $(l_1, l_2, k) \mapsto (3l_1 - l_2 + k, l_2, l_1 - l_2, l_1, k)$ . By (2.12), the extended nef cone is

$$\text{Nef}^S(\mathcal{X}) = \text{cone} \left\langle \begin{pmatrix} 3 \\ -1 \\ 1 \end{pmatrix}, \begin{pmatrix} 3 \\ 0 \\ 1 \end{pmatrix}, \begin{pmatrix} 0 \\ 0 \\ 1 \end{pmatrix} \right\rangle.$$

Therefore, the extended Mori cone  $\text{NE}^S \subseteq \mathbb{L}^S \otimes_{\mathbb{Z}} \mathbb{R}$  is defined by the inequalities  $3l_1 - l_2 + k \geq 0$ ,  $3l_1 + k \geq 0$ ,  $k \geq 0$ .

We will not write down a description of  $\Lambda_{\sigma}^S$  for every cone  $\sigma \in \Sigma$ . We just mention, for example, that if  $\sigma$  is the cone spanned by  $\rho_2$  and  $\rho_4$  then  $\Lambda_{\sigma}^S$  is defined by the conditions  $3l_1 - l_2 + k \in \mathbb{Z}$ ,  $l_1 - l_2 \in \mathbb{Z}$ ,  $k \in \mathbb{Z}$ . After a few computations one finds that

$$\Lambda \text{E}^S = \left\{ (3l_1 - l_2 + k, l_2, l_1 - l_2, l_1, k) \in \mathbb{R}^5 \mid \begin{array}{l} 3l_1 \in \mathbb{Z}, l_2 \in \mathbb{Z}, k \in \mathbb{N}, \\ 3l_1 - l_2 + k \geq 0, 3l_1 + k \geq 0 \end{array} \right\}.$$



The extended reduction function  $v^S: \Lambda E^S \rightarrow \text{Box}(\Sigma)$  is defined by

$$\begin{aligned} v^S(l_1, l_2, k) &= \lceil 3l_1 - l_2 + k \rceil \begin{pmatrix} 1 \\ -1 \end{pmatrix} + \lceil l_2 \rceil \begin{pmatrix} 0 \\ 1 \end{pmatrix} + \lceil l_1 - l_2 \rceil \begin{pmatrix} -1 \\ 2 \end{pmatrix} + \\ &\quad + \lceil l_1 \rceil \begin{pmatrix} -2 \\ 1 \end{pmatrix} + \lceil k \rceil \begin{pmatrix} -1 \\ 1 \end{pmatrix} \\ &= 3(\lceil l_1 \rceil - l_1) \begin{pmatrix} -1 \\ 1 \end{pmatrix}. \end{aligned}$$

Since  $s_1 = \frac{1}{3}\rho_3 + \frac{1}{3}\rho_4$ , we have that the image of  $(l_1, l_2, k) \in \mathbb{L}^S \otimes_{\mathbb{Z}} \mathbb{Q}$  in  $\mathbb{L} \otimes_{\mathbb{Z}} \mathbb{Q}$  via the splitting (2.11) is

$$d = \begin{pmatrix} 3l_1 - l_2 + k \\ l_2 \\ l_1 - l_2 + \frac{k}{3} \\ l_1 + \frac{k}{3} \end{pmatrix} = \left( l_1 + \frac{k}{3} \right) \begin{pmatrix} 3 \\ 0 \\ 1 \\ 1 \end{pmatrix} + l_2 \begin{pmatrix} -1 \\ 1 \\ -1 \\ 0 \end{pmatrix}. \quad (2.14)$$

Therefore, the  $S$ -extended Novikov variable corresponding to  $(l_1, l_2, k) \in \text{NE}^S(\mathcal{X})$  is  $\tilde{Q}^{(l_1, l_2, k)} = Q^d \xi^k$ , where  $d \in \text{NE}(X)$  is given by (2.14). To match notation with (2.13), set  $\mathbf{1}_{(0,0)} = \mathbf{1}_0$ ,  $\mathbf{1}_{(-1,1)} = \mathbf{1}_{2/3}$ ,  $\mathbf{1}_{(-2,2)} = \mathbf{1}_{4/3}$ . The Chern classes of the toric divisors are  $u_1 = 3p_1 - p_2$ ,  $u_2 = p_2$ ,  $u_3 = p_1 - p_2$ , and  $u_4 = p_1$ . Following Remark 2.15, by (2.13) the  $S$ -extended I-function  $I^S$  of  $\mathcal{X}$  is

$$I^S(\tau_1, \tau_2, \xi; z) = z e^{(\tau_1 p_1 + \tau_2 p_2)/z} \sum_{(l_1, l_2, k) \in \Lambda E^S} \tilde{Q}^{(l_1, l_2, k)} e^{\tau_1(l_1 + \frac{k}{3}) + \tau_2 l_2} \square_{(l_1, l_2, k)} \mathbf{1}_{v^S(l_1, l_2, k)},$$

where

$$\begin{aligned} \square_{(l_1, l_2, k)} &= \frac{1}{\prod_{\substack{0 < a \leq 3l_1 - l_2 + k \\ \langle a \rangle = \langle 3l_1 - l_2 + k \rangle}} (3p_1 - p_2 + az)} \times \\ &\quad \times \frac{\prod_{\substack{a \leq 0 \\ \langle a \rangle = \langle l_2 \rangle}} (p_2 + az)}{\prod_{\substack{a \leq l_2 \\ \langle a \rangle = \langle l_2 \rangle}} (p_2 + az)} \frac{\prod_{\substack{a \leq 0 \\ \langle a \rangle = \langle l_1 - l_2 \rangle}} (p_1 - p_2 + az)}{\prod_{\substack{a \leq l_1 - l_2 \\ \langle a \rangle = \langle l_1 - l_2 \rangle}} (p_1 - p_2 + az)} \frac{\prod_{\substack{a \leq 0 \\ \langle a \rangle = \langle l_1 \rangle}} (p_1 + az)}{\prod_{\substack{a \leq l_1 \\ \langle a \rangle = \langle l_1 \rangle}} (p_1 + az)} \frac{1}{k! z^k} \end{aligned}$$

Now we want to study the asymptotic behaviour of  $I^S$  with respect to the variable  $z$ . Note that if  $(l_1, l_2, k) \in \Lambda E^S$  and  $\deg_z \square_{(l_1, l_2, k)} \geq -1$  then either  $(l_1, l_2, k) = (0, 0, 0)$  or  $(l_1, l_2, k) = (-\frac{1}{3}, 0, 1)$ . Since  $\tilde{Q}^{(-\frac{1}{3}, 0, 1)} = \xi$  and  $v^S(-\frac{1}{3}, 0, 1) = (-1, 1)$ , we

obtain

$$\begin{aligned} I^S(\tau_1, \tau_2, \xi; z) &= ze^{(\tau_1 p_1 + \tau_2 p_2)/z} (\mathbf{1}_0 + z^{-1} \xi \mathbf{1}_{2/3} + O(z^{-2})) \\ &= z \mathbf{1}_0 + \tau_1 p_1 + \tau_2 p_2 + \xi \mathbf{1}_{2/3} + O(z^{-1}), \end{aligned}$$

where  $O(z^{-1})$  denotes term of the form  $\sum_{n=1}^{\infty} c_n z^{-n}$  with  $c_n$  independent of  $z$ .

Since the J-function is the only point of the Givental cone of  $\mathcal{X}$  with the asymptotic expansion  $z \mathbf{1}_0 + F(t) + O(z^{-1})$ , by the mirror theorem (Theorem 2.14) we have that  $J(\tau_1 p_1 + \tau_2 p_2 + \xi \mathbf{1}_{2/3}; z) = I^S(\tau_1, \tau_2, \xi; z)$  for every  $\tau_1, \tau_2, \xi$ . To obtain the quantum period of  $\mathcal{X}$ , we have to set  $z = 1$ ,  $\tau_1 = \tau_2 = 0$ ,  $\xi = t^{\frac{1}{3}} x$ , replace the Novikov variable  $Q^d$  with  $t^{-K_X \cdot d}$ , and take the component along  $\mathbf{1}_0$  of the  $J$ -function; namely,

$$\tilde{Q}^{(l_1, l_2, k)} = Q^{(l_1 + \frac{k}{3}, l_2)} \xi^k \mapsto t^{5(l_1 + \frac{k}{3}) - l_2} \left( x t^{\frac{1}{3}} \right)^k = x^k t^{5l_1 - l_2 + 2k}.$$

Thus the quantum period of  $\mathcal{X}$  is

$$G_{\mathcal{X}}(x; t) = \sum_{\substack{l_1, l_2, k \in \mathbb{Z}, \\ l_1 \geq l_2 \geq 0, k \geq 0, \\ 3l_1 + k \geq l_2}} \frac{1}{(3l_1 - l_2 + k)! l_2! (l_1 - l_2)! l_1! k!} x^k t^{5l_1 - l_2 + 2k}.$$

The regularised quantum period of  $X$  is

$$\widehat{G}_{\mathcal{X}}(x; t) = 1 + 2xt^2 + (12 + 6x^2)t^4 + 20t^5 + (120x + 20x^3)t^6 + \dots$$

Kasprzyk and Tveiten [KT] have shown that the maximally mutable Laurent polynomials with T-binomial coefficients on  $P$  are the 1-parameter family

$$f_a(x, y) = \frac{y^2}{x} + \frac{y}{x^2} + \frac{x}{y} + y + a \frac{y}{x}$$

with parameter  $a$ . After identifying the parameter  $x$  in  $\widehat{G}_{\mathcal{X}}$  with the parameter  $a$  we see that  $\widehat{G}_{\mathcal{X}}$  coincides with  $\pi_{f_a}$ .

## 2.4. Toric complete intersections

### 2.4.1. The quantum Lefschetz principle

The Gromov–Witten invariants of a complete intersection are governed by the so-called ‘quantum Lefschetz principle’, which was formulated and proven by Coates and Givental [CG07] in the case of smooth projective varieties (see also [Lee01] and

[Kim99]). It has been shown that this principle fails for some positive line bundles on some orbifolds [CGI<sup>+</sup>12], but there is evidence that it holds in cases which are sufficient for us.

Firstly we have to define twisted Gromov–Witten invariants. Let  $\mathcal{Y}$  be a proper smooth Deligne–Mumford stack over  $\mathbb{C}$  with projective coarse moduli space  $Y$  and let  $\mathcal{E}$  be a vector bundle on  $\mathcal{Y}$ . For  $d \in \text{Eff}(\mathcal{Y})$ , the universal genus zero  $n$ -pointed stable map

$$\begin{array}{ccc} \mathcal{C}_{0,n,d} & \xrightarrow{\text{ev}} & \mathcal{Y} \\ \pi \downarrow & & \\ \mathcal{Y}_{0,n,d} & & \end{array}$$

induces an element  $\mathcal{E}_{0,n,d} := \pi_! \text{ev}^* \mathcal{E}$  in the K-theory of  $\mathcal{Y}_{0,n,d}$ . Let the torus  $\mathbb{C}^\times$  act on  $\mathcal{E}$  rotating the fibres and leaving the base  $\mathcal{Y}$  invariant. This action induces an action of  $\mathbb{C}^\times$  on  $\mathcal{E}_{0,n,d}$ . Let  $\mathbf{e}$  be the  $\mathbb{C}^\times$ -equivariant Euler class, which is invertible over the field of fractions  $\mathbb{Q}(\kappa)$  of  $H_{\mathbb{C}^\times}^\bullet(\text{pt}; \mathbb{Q}) = H^\bullet(\text{BC}^\times; \mathbb{Q}) = \mathbb{Q}[\kappa]$ , where  $\kappa$  is the equivariant parameter given by the first Chern class of the line bundle  $\mathcal{O}(1)$  on  $\mathbb{C}\mathbb{P}^\infty = \text{BC}^\times$ .  $\mathcal{E}$ -twisted Gromov–Witten invariants are defined by

$$\langle \alpha_1 \psi^{k_1}, \dots, \alpha_n \psi^{k_n} \rangle_{0,n,d}^{\text{tw}} := \int_{[\mathcal{Y}_{0,n,d}]^{\text{vir}}} \mathbf{e}(\mathcal{E}_{0,n,d}) \cup \prod_{i=1}^n (\text{ev}_i^*(\alpha_i) \cup \psi_i^{k_i}) \in \mathbb{Q}(\kappa),$$

for  $\alpha_1, \dots, \alpha_n \in H_{\text{CR}}^\bullet(\mathcal{Y})$  and non-negative integers  $k_1, \dots, k_n$ . The inertia stack  $\text{I}\mathcal{E}$  of the total space of the vector bundle  $\mathcal{E} \rightarrow \mathcal{Y}$  is a vector bundle over  $\text{I}\mathcal{Y}$ : the fibre of  $\text{I}\mathcal{E}$  over the point  $(y, g)$  is the  $g$ -fixed subspace of the fibre of  $\mathcal{E}$  over  $y$ . One can define the twisted Poincaré pairing

$$(\alpha, \beta)_{\text{CR}}^{\text{tw}} := \int_{\text{I}\mathcal{X}} \alpha \cup \text{inv}^* \beta \cup \mathbf{e}(\text{I}\mathcal{E}) \in \mathbb{Q}[\kappa], \quad \alpha, \beta \in H_{\text{CR}}^\bullet(\mathcal{Y})$$

and the twisted symplectic form  $\Omega^{\text{tw}}(f, g) := -\text{Res}_{z=\infty} (f(-z), g(z))_{\text{CR}}^{\text{tw}} dz$  on  $\mathcal{H}_{\mathcal{Y}} \otimes_{\mathbb{C}} \mathbb{C}(\kappa)$ , where  $\mathcal{H}_{\mathcal{Y}}$  is defined in (2.1). In the symplectic vector space  $(\mathcal{H}_{\mathcal{Y}} \otimes_{\mathbb{C}} \mathbb{C}(\kappa), \Omega^{\text{tw}})$  there is a Lagrangian submanifold, which is a formal germ of a cone with vertex at the origin and which encodes all genus-zero Euler-twisted Gromov–Witten invariants of  $\mathcal{Y}$ : it is called the *twisted Givental cone* and is denoted by  $\mathcal{L}_{\mathcal{Y}}^{\text{tw}}$ . We will not give a precise definition of  $\mathcal{L}_{\mathcal{Y}}^{\text{tw}}$  here, referring the reader to [Tse10], [CCIT09].  $\mathcal{L}_{\mathcal{Y}}^{\text{tw}}$  determines and is determined by Givental’s *twisted J-function*:

$$J_{\mathcal{Y}}^{\text{tw}}(\gamma, z) = z + \gamma + \sum_{d \in \text{Eff}(\mathcal{X})} \sum_{n=0}^{\infty} \sum_{k=0}^{\infty} \sum_{\epsilon=1}^N \frac{Q^d}{n!} \langle \gamma, \dots, \gamma, \phi_{\mathbf{e}}^\epsilon \psi^k \rangle_{0,n+1,d}^{\text{tw}} \phi_\epsilon z^{-k-1},$$

where  $\gamma$  runs in the even part  $H_{\text{CR}}^\bullet(\mathcal{Y})$  of the Chen–Ruan orbifold cohomology of  $\mathcal{Y}$  and  $\{\phi_1, \dots, \phi_N\}$  and  $\{\phi_e^1, \dots, \phi_e^N\}$  are homogeneous bases of the  $\mathbb{Q}(\kappa)$ -vector space  $H_{\text{CR}}^\bullet(\mathcal{Y}) \otimes_{\mathbb{Q}} \mathbb{Q}(\kappa)$  which are dual with respect to the twisted Poincaré pairing  $(\cdot, \cdot)_{\text{CR}}^{\text{tw}}$ . The cone  $\mathcal{L}_{\mathcal{Y}}^{\text{tw}}$  determines the twisted J-function because  $J_{\mathcal{Y}}^{\text{tw}}(\gamma, -z)$  is the unique point on  $\mathcal{L}_{\mathcal{Y}}^{\text{tw}}$  of the form  $-z + \gamma + O(z^{-1})$ . Actually  $\mathcal{L}_{\mathcal{Y}}^{\text{tw}}$  is a family of cones in  $\mathcal{H}_{\mathcal{Y}}$  and  $J_{\mathcal{Y}}^{\text{tw}}$  is a family of elements in  $\mathcal{H}_{\mathcal{Y}}$ . Both families are parametrised by the equivariant parameter  $\kappa$  in some open set of  $\mathbb{A}_{\mathbb{C}}^1$ .

Now we are going to say what is the relationship between  $\mathcal{E}$ -twisted Gromov–Witten invariants of  $\mathcal{Y}$  and the ordinary Gromov–Witten invariants of the zero locus  $\mathcal{X}$  of a generic global section of  $\mathcal{E}$ . Before doing that, we introduce the class of convex vector bundles.

The vector bundle  $\mathcal{E}$  over  $\mathcal{Y}$  is *convex* if  $H^1(\mathcal{C}, f^*\mathcal{E}) = 0$  for all genus-zero  $n$ -pointed stable maps  $f: \mathcal{C} \rightarrow \mathcal{Y}$ , for any  $n$ . If  $\mathcal{E}$  is convex, then  $R^1\pi_*\text{ev}^*\mathcal{E} = 0$  and by cohomology and base change  $\mathcal{E}_{0,n,d}$  is the class of the vector bundle  $\pi_*\text{ev}^*\mathcal{E}$  over  $\mathcal{Y}_{0,n,d}$ , for all  $n \in \mathbb{N}$  and  $d \in \text{Eff}(\mathcal{Y})$ . Therefore, every  $\mathcal{E}$ -twisted Gromov–Witten invariant lies in  $\mathbb{Q}[\kappa]$ . A line bundle on  $\mathcal{Y}$  is convex if and only if it is the pull-back of a nef line bundle from the coarse moduli space  $Y$  (see [CGI<sup>+</sup>12]).

Now we consider the following setup.

**Setup 2.16.**  $\mathcal{Y}$  is a proper smooth Deligne–Mumford stack over  $\mathbb{C}$  with projective coarse moduli space;  $\mathcal{E}$  is a vector bundle on  $\mathcal{Y}$  and  $i: \mathcal{X} \hookrightarrow \mathcal{Y}$  is the closed substack defined by a regular section of  $\mathcal{E}$ ;  $\iota^*: H_{\text{CR}}^\bullet(\mathcal{Y}) \rightarrow H_{\text{CR}}^\bullet(\mathcal{X})$  is the pull-back defined by the inclusion  $\iota: \mathcal{X} \hookrightarrow \mathcal{Y}$ ;  $J_{\mathcal{Y}}^{\text{tw}}$  is the  $\mathcal{E}$ -twisted J-function of  $\mathcal{Y}$  and  $J_{\mathcal{X}}$  is the non-twisted J-function of  $\mathcal{X}$ ;  $\mathcal{L}_{\mathcal{Y}}^{\text{tw}}$  is the  $\mathcal{E}$ -twisted Givental cone of  $\mathcal{Y}$  and  $\mathcal{L}_{\mathcal{X}}$  is the non-twisted Givental cone of  $\mathcal{X}$ .

Under the hypothesis that the vector bundle  $\mathcal{E}$  is convex, the following theorem relates the Gromov–Witten invariants of the complete intersection to the twisted invariants of the ambient.

**Theorem 2.17** ([Iri11, Coa]). *Let  $\mathcal{Y}, \mathcal{E}, \mathcal{X}$  be as in Setup 2.16. If  $\mathcal{E}$  is convex, then the non-equivariant limit  $\lim_{\kappa \rightarrow 0} J_{\mathcal{Y}}^{\text{tw}}$  is well-defined and satisfies:*

$$\iota^* \left( \lim_{\kappa \rightarrow 0} J_{\mathcal{Y}}^{\text{tw}}(\gamma) \right) = J_{\mathcal{X}}(\iota^*\gamma)$$

for all  $\gamma \in H_{\text{CR}}^\bullet(\mathcal{Y})$ . Moreover, if  $I^{\text{tw}}$  is a point of  $\mathcal{L}_{\mathcal{Y}}^{\text{tw}}$ , then the non-equivariant limit  $I_{\mathcal{X}, \mathcal{Y}} := \iota^* (\lim_{\kappa \rightarrow 0} I^{\text{tw}})$  is well-defined and lies in  $\mathcal{L}_{\mathcal{X}}$ .

Without the convexity hypothesis, it is conjectured that there is some relation between invariants of the complete intersection and twisted invariants of the ambient.

**Conjecture 2.18** (Coates–Corti–Iritani–Tseng [CCITa], cf. [CGI<sup>+</sup>12]). *Let  $\mathcal{Y}, \mathcal{E}, \mathcal{X}$  be as in Setup 2.16. Let  $I^{\text{tw}}$  be a point of  $\mathcal{L}_{\mathcal{Y}}^{\text{tw}}$  such that the non-equivariant limit  $I_{\mathcal{X}, \mathcal{Y}} := \lim_{\kappa \rightarrow 0} \iota^* I^{\text{tw}}$  is well-defined. Then  $I_{\mathcal{X}, \mathcal{Y}}$  lies in  $\mathcal{L}_{\mathcal{X}}$ .*

**Remark 2.19.** In Theorem 2.17 and Conjecture 2.18 we have applied the homomorphism  $Q^\delta \mapsto Q^{i^*\delta}$  to the Novikov ring of  $\mathcal{X}$ .

### 2.4.2. Quantum Lefschetz for toric orbifolds

Here we discuss twisted Gromov–Witten invariants of toric orbifolds. We maintain all the notations we used in §2.3.1. In particular, we assume that  $\mathcal{Y}$  is a toric well-formed orbifold coming from the stacky fan  $(N, \Sigma, \rho)$ , where  $N$  is a finitely generated free abelian group,  $\Sigma$  is a complete simplicial fan in  $N_{\mathbb{R}}$  and  $\rho$  is the ray map of  $\Sigma$ . We denote by  $Y$  the toric variety that is the coarse moduli space of  $\mathcal{Y}$ . We also use the formalism of  $S$ -extended stacky fans introduced in §2.3.1, where  $S$  is a finite set with a map  $S \rightarrow N$ .

Let  $\mathcal{E}_1, \dots, \mathcal{E}_r$  be line bundles on  $\mathcal{Y}$ . Consider the vector bundle  $\mathcal{E} = \mathcal{E}_1 \oplus \dots \oplus \mathcal{E}_r$  on  $\mathcal{Y}$  and choose  $\varepsilon_1, \dots, \varepsilon_r \in \mathbb{L}^{S^\vee}$  such that their images  $E_1, \dots, E_r$  in  $\mathbb{L}^\vee$  are the first Chern classes of  $\mathcal{E}_1, \dots, \mathcal{E}_r$ . The  $S$ -extended  $\mathcal{E}$ -twisted  $I$ -function (see [CCITb]) of  $\mathcal{Y}$  is:

$$I_{\mathcal{E}}^S(\tau, \xi; z) := z e^{\sum_{i=1}^n u_i \tau_i / z} \times \sum_{\lambda \in \Lambda E^S} \tilde{Q}^\lambda e^{\lambda \tau} \left( \frac{\prod_{i=1}^{n+m} \prod_{\substack{a \leq 0 \\ \langle a \rangle = \langle \lambda_i \rangle}} (u_i + az)}{\prod_{i=1}^{n+m} \prod_{\substack{a \leq \lambda_i \\ \langle a \rangle = \langle \lambda_i \rangle}} (u_i + az)} \right) \left( \frac{\prod_{j=1}^r \prod_{\substack{a \leq \varepsilon_j \cdot \lambda \\ \langle a \rangle = \langle \varepsilon_j \cdot \lambda \rangle}} (\kappa + E_j + az)}{\prod_{j=1}^r \prod_{\substack{a \leq 0 \\ \langle a \rangle = \langle \varepsilon_j \cdot \lambda \rangle}} (\kappa + E_j + az)} \right) \mathbf{1}_{v^S(\lambda)} \quad (2.15)$$

where:

- $\kappa$  is the equivariant parameter;
- $\tau = (\tau_1, \dots, \tau_n)$  and  $\xi = (\xi_1, \dots, \xi_m)$  are formal variables;
- for  $1 \leq i \leq n$ ,  $u_i \in H^2(\mathcal{Y}; \mathbb{Q})$  is the first Chern class of the the line bundle corresponding to the  $i$ th toric divisor  $D_i$ ;
- for  $n+1 \leq i \leq n+m$ ,  $u_i$  is defined to be zero;
- for  $\lambda \in \Lambda E^S$ ,  $\tilde{Q}^\lambda := Q^d \xi_1^{k_1} \dots \xi_m^{k_m} \in \mathbf{\Lambda}[\xi_1, \dots, \xi_m]$ , where  $d \in \mathbb{L} \otimes_{\mathbb{Z}} \mathbb{Q}$  and  $k \in \mathbb{N}^m$  are such that  $\lambda$  corresponds to  $(d, k)$  via (2.11) and  $Q^d$  denotes the representative of  $d \in \text{Eff}(\mathcal{Y})$  in the Novikov ring  $\mathbf{\Lambda}$ ;

- for  $\lambda \in \Lambda E^S$ ,  $e^{\lambda\tau} := \prod_{i=1}^n e^{(p_i \cdot d)\tau_i}$ ;
- for  $\lambda \in \Lambda E^S$ ,  $\mathbf{1}_{v^S(\lambda)} \in H^0(\mathcal{Y}_{v^S(\lambda)}; \mathbb{Q}) \subseteq H_{\text{CR}}^{2\text{age}(v^S(\lambda))}(\mathcal{Y})$  is the identity class supported on the component of inertia associated to  $v^S(\lambda) \in \text{Box}(\Sigma)$ .

Note that  $I_{\mathcal{E}}^S$  depends on the choice of the liftings  $\varepsilon_j$  of  $E_j = c_1(\mathcal{E}_j) \in \mathbb{L}^\vee$  to  $\mathbb{L}^{S\vee}$ .

**Remark 2.20.** For the twisted I-function (2.15) we use the same substitutions as in Remark 2.15.

**Theorem 2.21** (Twisted mirror theorem for toric stacks [CCITb]). *Let  $Y$  be a projective simplicial toric variety, associated to the fan  $\Sigma$  in the lattice  $N$ , and let  $\mathcal{Y}$  be the corresponding toric well-formed orbifold. Let  $S$  be a finite set equipped with a map to  $N$ . Let  $\mathcal{E}_1, \dots, \mathcal{E}_r \in \text{Pic}(\mathcal{Y})$  be line bundles and let  $\mathcal{E} = \mathcal{E}_1 \oplus \dots \oplus \mathcal{E}_r$ .*

*For any choice of the liftings of  $E_j = c_1(\mathcal{E}_j) \in \mathbb{L}^\vee$  to  $\mathbb{L}^{S\vee}$ , the  $S$ -extended  $\mathcal{E}$ -twisted I-function  $I_{\mathcal{E}}^S(\tau, \xi, -z)$  lies in the  $\mathcal{E}$ -twisted Givental cone  $\mathcal{L}_{\mathcal{Y}}^{\text{tw}}$  for all values of the parameters  $\tau$  and  $\xi$ .*

**Remark 2.22.** The theorem above is useful when computing Gromov–Witten invariants of complete intersections in toric orbifolds. Assume we are in the situation of Theorem 2.21. Let  $i: \mathcal{X} \hookrightarrow \mathcal{Y}$  be the zero locus of a regular section of  $\mathcal{E}$  and  $\iota^*: H_{\text{CR}}^\bullet(\mathcal{Y}) \rightarrow H_{\text{CR}}^\bullet(\mathcal{X})$  be the pull-back given by the inclusion  $\iota: \mathcal{X} \hookrightarrow \mathcal{Y}$ .

- (i) Suppose that  $I_{\mathcal{E}}^S(\tau, \xi, z) = z\mathbf{1}_0 + F(\tau, \xi) + O(z^{-1})$  and the line bundles  $\mathcal{E}_1, \dots, \mathcal{E}_r$  are convex. Then  $I_{\mathcal{E}}^S$  determines the  $\mathcal{E}$ -twisted J-function of  $\mathcal{Y}$ . We may apply Theorem 2.17 to obtain the J-function of  $\mathcal{X}$ .
- (ii) Assume that the non-equivariant limit  $I_{\mathcal{X}, \mathcal{Y}} := \lim_{\kappa \rightarrow 0} \iota^* I_{\mathcal{E}}^S$  is well-defined. If Conjecture 2.18 holds and  $I_{\mathcal{X}, \mathcal{Y}} = z\mathbf{1}_0 + F(\tau, \xi) + O(z^{-1})$ , then  $I_{\mathcal{X}, \mathcal{Y}}$  determines the J-function of  $\mathcal{X}$ .

In §2.4.3 and §2.4.4 we give two examples of this.

### 2.4.3. Example of a toric complete intersection: $X_{2,8/3}$

In the lattice  $N = \mathbb{Z}^3$  consider the polytope such that its vertices are the columns of the matrix

$$\rho = \begin{pmatrix} 1 & 0 & 0 & -1 & 3 \\ 0 & 1 & 0 & -1 & 3 \\ 0 & 0 & 1 & -1 & 2 \end{pmatrix}$$

and consider its spanning fan  $\Sigma$ . It contains six 3-dimensional cones:  $\sigma_{235}$ ,  $\sigma_{234}$ ,  $\sigma_{135}$ ,  $\sigma_{134}$ ,  $\sigma_{125}$ ,  $\sigma_{124}$ , where  $\sigma_{ijk}$  is the cone spanned by the  $i$ th, the  $j$ th and the

$k$ th columns of  $\rho$ . Let  $\mathcal{Y}$  be the toric orbifold associated to the stacky fan  $(N, \Sigma, \rho)$ . The rows of the matrix

$$D = \begin{pmatrix} 1 & 1 & 1 & 1 & 0 \\ 0 & 0 & 1 & 3 & 1 \end{pmatrix}.$$

constitute a basis of  $\mathbb{L} = \ker \rho$ . Therefore, the fan sequence (2.5) is

$$0 \longrightarrow \mathbb{L} \simeq \mathbb{Z}^2 \xrightarrow{tD} \mathbb{Z}^5 \xrightarrow{\rho} N = \mathbb{Z}^3 \longrightarrow 0$$

and the divisor sequence (2.6) is

$$0 \longrightarrow M = \mathbb{Z}^3 \xrightarrow{t\rho} \mathbb{Z}^5 \xrightarrow{D} \mathbb{L}^\vee \simeq \mathbb{Z}^2 \longrightarrow 0.$$

Let  $\{p_1, p_2\}$  be the basis of  $\mathbb{L}^\vee$  coming from the isomorphism  $\mathbb{L} \simeq \mathbb{Z}^2$  chosen above. The nef cone of  $Y$  is  $\text{Nef}(Y) = \text{cone}\langle p_1 + p_2, p_1 + 3p_2 \rangle$ . We see that  $Y$  is a Fano 3-fold. If we use  $x_0, x_1, y, z, t$  as coordinates on  $\mathbb{A}^5$ , the irrelevant ideal is  $\text{Irr}_\Sigma = (x_0, x_1, y) \cdot (z, t)$ . Considering the open set  $U_\Sigma = \mathbb{A}_\mathbb{C}^5 \setminus V(\text{Irr}_\Sigma)$ , the toric variety  $Y$  is given by the quotient  $U_\Sigma / \mathbb{G}_m^2$ , under the action of  $\mathbb{G}_m^2$  on  $\mathbb{A}^5$  induced by the matrix  $D$ , and the toric orbifold  $\mathcal{Y}$  is the stack-theoretic quotient  $[U_\Sigma / \mathbb{G}_m^2]$ .

The singular locus of  $Y$  has two components: a rational curve  $C$ , corresponding to the cone  $\sigma_{35}$  and made up of the points  $[x_0 : x_1 : 0 : 1 : 0]$ , and the point  $P = [0 : 0 : 1 : 1 : 0]$ , corresponding to the cone  $\sigma_{125}$ . A neighbourhood of every point of  $C$  in  $Y$  is isomorphic to  $\frac{1}{3}(1, 1) \times \mathbb{A}^1$ . One can see that a neighbourhood of  $P$  in  $Y$  is isomorphic to  $\frac{1}{2}(1, 1, 1)$ . The connected components of the inertia stack  $\text{I}\mathcal{Y}$  are indexed by  $\text{Box}(\Sigma) = \{(0, 0, 0), (1, 1, 1), (2, 2, 2), (2, 2, 1)\}$ , with ages  $0, \frac{2}{3}, \frac{4}{3}, \frac{3}{2}$  respectively.

Let  $\mathcal{X} \hookrightarrow \mathcal{Y}$  be the hypersurface defined by a generic section of the line bundle  $\mathcal{E}$  on  $\mathcal{Y}$  with  $c_1(\mathcal{E}) = 3p_1 + 3p_2$ . Such a generic section is of the form

$$f(x_0, x_1, y, z, t) = f_3(x_0, x_1)t^3 + f_2(x_0, x_1)(ayt^2 + bz) + f_1(x_0, x_1)y^2t + cy^3,$$

where  $a, b, c \in \mathbb{C}$  and  $f_i(x_0, x_1)$  denotes a homogeneous polynomial of degree  $i$  in the variables  $x_0, x_1$ . Since  $f(0, 0, 1, 1, 0) = c$ , we see that a generic choice for  $f$  implies  $P \notin X$ . Moreover, since  $f(x_0, x_1, 0, 1, 0) = f_2(x_0, x_1)b$ , we see that the surface  $X$  intersects the curve  $C$  in two points. For each of these two points there is a neighbourhood in  $X$  that is analytically isomorphic to  $\frac{1}{3}(1, 1)$ .

By adjunction  $-K_X = (-K_Y - E)|_X = (4p_1 + 5p_2 - 3p_1 - 3p_2)|_X = (p_1 + 2p_2)|_X$ , which is ample. Therefore  $X$  is a del Pezzo surface with two singular points of type  $\frac{1}{3}(1, 1)$ . Using the relations  $(p_1 + 3p_2)p_2 = 0$ ,  $p_1^2(p_1 + p_2) = 0$  and  $p_1^2p_2 = \frac{1}{2}$  that hold

in  $H^\bullet(Y, \mathbb{Q})$ , one can show that the degree of  $X$  is  $K_X^2 = (p_1 + 2p_2)^2(3p_1 + 3p_2) = \frac{8}{3}$ . Hence  $X = X_{2,8/3}$ .

Now we ‘extend’ with the vector  $(1, 1, 1)$ . In other words, we consider the map  $S = \{1\} \rightarrow N$  with  $s_1 = (1, 1, 1) \in N$  and the corresponding stacky fan. The extended fan sequence (2.9) and the extended divisor sequence (2.10) are given by the matrices

$$\rho^S = \begin{pmatrix} 1 & 0 & 0 & -1 & 3 & 1 \\ 0 & 1 & 0 & -1 & 3 & 1 \\ 0 & 0 & 1 & -1 & 2 & 1 \end{pmatrix} \quad \text{and} \quad D^S = \begin{pmatrix} 1 & 1 & 1 & 1 & 0 & 0 \\ 0 & 0 & 1 & 3 & 1 & 0 \\ 0 & 0 & 0 & 1 & 0 & 1 \end{pmatrix}.$$

We identify  $\mathbb{L}^S$  with  $\mathbb{Z}^3$  by choosing the basis given by the rows of  $D^S$ . We call  $l_1, l_2, k$  the coordinates with respect to this basis; thus, the inclusion  $\mathbb{L}^S \otimes_{\mathbb{Z}} \mathbb{R} \hookrightarrow \mathbb{R}^6$  is given by  $(l_1, l_2, k) \mapsto (l_1, l_1, l_1 + l_2, l_1 + 3l_2 + k, l_2, k)$ . One can check that

$$\text{Nef}^S(\mathcal{Y}) = \text{cone} \left\langle \begin{pmatrix} 1 \\ 3 \\ 1 \end{pmatrix}, \begin{pmatrix} 3 \\ 3 \\ 1 \end{pmatrix}, \begin{pmatrix} 0 \\ 0 \\ 1 \end{pmatrix} \right\rangle$$

and

$$\Lambda E^S = \left\{ \left( \begin{pmatrix} l_1 \\ l_1 \\ l_1 + l_2 \\ l_1 + 3l_2 + k \\ l_2 \\ k \end{pmatrix} \in \mathbb{Q}^6 \mid \begin{array}{l} l_1 + 3l_2 + k \geq 0 \\ 3l_1 + 3l_2 + k \geq 0 \\ k \in \mathbb{N} \\ (l_1 \in \mathbb{Z}, 3l_2 \in \mathbb{Z}) \text{ or } (l_1 + l_2 \in \mathbb{Z}, 2l_2 \in \mathbb{Z}) \end{array} \right. \right\}.$$

The extended reduction function  $v^S: \Lambda E^S \rightarrow \text{Box}(\Sigma)$  is given by

$$\begin{aligned} v^S(l_1, l_2, k) &= [l_1] \begin{pmatrix} 1 \\ 0 \\ 0 \end{pmatrix} + [l_1] \begin{pmatrix} 0 \\ 1 \\ 0 \end{pmatrix} + [l_1 + l_2] \begin{pmatrix} 0 \\ 0 \\ 1 \end{pmatrix} + \\ &+ [l_1 + 3l_2 + k] \begin{pmatrix} -1 \\ -1 \\ -1 \end{pmatrix} + [l_2] \begin{pmatrix} 3 \\ 3 \\ 2 \end{pmatrix} + [k] \begin{pmatrix} 1 \\ 1 \\ 1 \end{pmatrix} \\ &= \begin{pmatrix} [l_1] - [l_1 + 3l_2] + 3[l_2] \\ [l_1] - [l_1 + 3l_2] + 3[l_2] \\ [l_1 + l_2] - [l_1 + 3l_2] + 2[l_2] \end{pmatrix}. \end{aligned}$$



We get:  $v^S(l_1, l_2, k) = (0, 0, 0)$  if  $l_1, l_2 \in \mathbb{Z}$ ;  $v^S(l_1, l_2, k) = (2, 2, 2)$  if  $l_1 \in \mathbb{Z}, l_2 \in \frac{1}{3} + \mathbb{Z}$ ;  $v^S(l_1, l_2, k) = (1, 1, 1)$  if  $l_1 \in \mathbb{Z}, l_2 \in \frac{2}{3} + \mathbb{Z}$ ;  $v^S(l_1, l_2, k) = (2, 2, 1)$  if  $l_1, l_2 \in \frac{1}{2} + \mathbb{Z}$ . Since  $s_1 = \frac{1}{3}\rho_3 + \frac{1}{3}\rho_5$ , the image of  $(l_1, l_2, k) \in \mathbb{L}^S \otimes_{\mathbb{Z}} \mathbb{Q}$  in  $\mathbb{L} \otimes_{\mathbb{Z}} \mathbb{Q}$  via the splitting (2.11) is

$$d = \begin{pmatrix} l_1 \\ l_1 \\ l_1 + l_2 + \frac{k}{3} \\ l_1 + 3l_2 + k \\ l_2 + \frac{k}{3} \end{pmatrix} = l_1 \begin{pmatrix} 1 \\ 1 \\ 1 \\ 1 \\ 0 \end{pmatrix} + \left( l_2 + \frac{k}{3} \right) \begin{pmatrix} 0 \\ 0 \\ 1 \\ 3 \\ 1 \end{pmatrix}.$$

Therefore for  $\lambda = (l_1, l_2, k) \in \Lambda E^S$  we have  $\tilde{Q}^\lambda = Q^{(l_1, l_2 + \frac{k}{3})} \xi^k$ .

We take  $\varepsilon = (3, 3, 1)$  as a lifting of the line bundle  $E = 3p_1 + 3p_2 \in \mathbb{L}^\vee$  to  $\mathbb{L}^{S^\vee}$ . If we denote by  $\kappa$  the equivariant parameter, the  $S$ -extended  $\mathcal{E}$ -twisted I-function (2.15) is

$$\begin{aligned} I_{\mathcal{E}}^S(\tau_1, \tau_2, \xi; z) &= z e^{(\tau_1 p_1 + \tau_2 p_2)/z} \sum_{(l_1, l_2, k) \in \Lambda E^S} \tilde{Q}^{(l_1, l_2, k)} e^{\tau_1 l_1 + \tau_2 (l_2 + \frac{k}{3})} \times \\ &\times \left( \frac{\prod_{\substack{a \leq 0 \\ \langle a \rangle = \langle l_1 \rangle}} (p_1 + az)}{\prod_{\substack{a \leq l_1 \\ \langle a \rangle = \langle l_1 \rangle}} (p_1 + az)} \right)^2 \frac{\prod_{\substack{a \leq 0 \\ \langle a \rangle = \langle l_1 + l_2 \rangle}} (p_1 + p_2 + az)}{\prod_{\substack{a \leq l_1 + l_2 \\ \langle a \rangle = \langle l_1 + l_2 \rangle}} (p_1 + p_2 + az)} \times \\ &\times \frac{\prod_{\substack{a \leq 0 \\ \langle a \rangle = \langle l_1 + 3l_2 + k \rangle}} (p_1 + 3p_2 + az)}{\prod_{\substack{a \leq l_1 + 3l_2 + k \\ \langle a \rangle = \langle l_1 + 3l_2 + k \rangle}} (p_1 + 3p_2 + az)} \frac{\prod_{\substack{a \leq 0 \\ \langle a \rangle = \langle l_2 \rangle}} (p_2 + az)}{\prod_{\substack{a \leq l_2 \\ \langle a \rangle = \langle l_2 \rangle}} (p_2 + az)} \times \\ &\times \frac{1}{k! z^k} \prod_{\substack{0 \leq a \leq 3l_1 + 3l_2 + k \\ \langle a \rangle = \langle 3l_1 + 3l_2 + k \rangle}} (3p_1 + 3p_2 + \kappa + az) \mathbf{1}_{v^S(l_1, l_2, k)}. \end{aligned}$$

The degree of the summand corresponding to  $\lambda \in \Lambda E^S$  with respect to  $z$  is not smaller than  $-1$  if and only if  $\lambda \in \{(0, 0, 0), (1, 0, 0), (0, 0, 1), (0, -\frac{1}{3}, 1), (1, -\frac{1}{3}, 0)\}$ . Therefore

$$\begin{aligned} I_{\mathcal{E}}^S(\tau_1, \tau_2, \xi; z) &= z \mathbf{1}_0 + \tau_1 p_1 + \tau_2 p_2 + \left( 6Q^{(1,0)} e^{\tau_1} + Q^{(0, \frac{1}{3})} \xi e^{\frac{\tau_2}{3}} \right) \mathbf{1}_0 + \\ &+ \left( \xi + 3Q^{(1, -\frac{1}{3})} e^{\tau_1 - \frac{\tau_2}{3}} \right) \mathbf{1}_{(1,1,1)} + O(z^{-1}). \end{aligned}$$

By the mirror theorem, the  $\mathcal{E}$ -twisted J-function of  $\mathcal{Y}$  is such that

$$\mathcal{J}_{\mathcal{Y}}^{\text{tw}} \left( \left( \xi + 3Q^{(1, -\frac{1}{3})} \right) \mathbf{1}_{(1,1,1)}, z \right) = \exp \left( -z^{-1} \left( 6Q^{(1,0)} + Q^{(0, \frac{1}{3})} \xi \right) \right) \cdot I_{\mathcal{E}}^S(0, 0, \xi; z).$$

By Conjecture 2.18,

$$I_{\mathcal{X},\mathcal{Y}}\left(\left(\xi + 3Q^{(1,-\frac{1}{3})}\right) \iota^* \mathbf{1}_{(1,1,1)}, z\right) := \lim_{\kappa \rightarrow 0} \iota^* J_{\mathcal{Y}}^{\text{tw}}\left(\left(\xi + 3Q^{(1,-\frac{1}{3})}\right) \mathbf{1}_{(1,1,1)}, z\right)$$

lies on the Givental cone of  $\mathcal{X}$ . Therefore

$$I_{\mathcal{X},\mathcal{Y}}\left(\eta \iota^* \mathbf{1}_{(1,1,1)}, z\right) = \exp\left(-z^{-1}\left(3Q^{(1,0)} + Q^{(0,\frac{1}{3})}\eta\right)\right) \lim_{\kappa \rightarrow 0} I_{\mathcal{E}}^S\left(0, 0, \eta - 3Q^{(1,-\frac{1}{3})}; z\right).$$

Let  $\mathbf{1}_1, \mathbf{1}_2$  denote the two identity classes of the components of  $\text{I}\mathcal{X}$  with age equal to  $2/3$ . Now we compute a specialisation of the quantum period  $G_{\mathcal{X}}(x_1, x_2; t) \in \mathbb{Q}[x_1, x_2][[t]]$  of  $\mathcal{X}$ . Since  $\iota^* \mathbf{1}_{(1,1,1)} = \mathbf{1}_1 + \mathbf{1}_2$ , setting  $z = 1$  and  $\eta = xt^{\frac{1}{3}}$ , replacing  $Q^{(\alpha_1, \alpha_2)} \mapsto t^{\alpha_1 + 2\alpha_2}$  (and consequently  $\tilde{Q}^{(l_1, l_2, k)} \mapsto t^{l_1 + 2l_2 + k}(x - 3)^k$ ), and considering the component along  $\mathbf{1}_0$  only, we get

$$G_{\mathcal{X}}(x, x; t) = e^{-xt - 3t} \sum_{l_1, l_2, k \in \mathbb{N}} \frac{(3l_1 + 3l_2 + k)!}{(l_1!)^2 l_2! (l_1 + l_2)! (l_1 + 3l_2 + k)! k!} (x - 3)^k t^{l_1 + 2l_2 + k}.$$

Since the two singular points of  $X$  lie in the same component of the singular locus of  $Y$ , we are able to compute  $G_{\mathcal{X}}(x_1, x_2; t)$  only for  $x_1 = x_2$ . It is possible that, if we had used another model of  $X$  as a complete intersection in a toric orbifold, we could have been able to compute the whole quantum period of  $\mathcal{X}$ . A specialization of the regularised quantum period is

$$\begin{aligned} \widehat{G}_{\mathcal{X}}(x, x; t) &= 1 + (12x + 20)t^2 + (6x^2 + 108x + 168)t^3 \\ &\quad + (396x^2 + 1800x + 2220)t^4 \\ &\quad + (360x^3 + 7980x^2 + 26640x + 27600)t^5 + \dots \end{aligned}$$

On the other hand, we consider the Fano polygon  $P$  whose vertices are the columns of

$$\begin{pmatrix} 1 & -1 & -1 & 2 \\ 1 & 2 & -1 & -1 \end{pmatrix}.$$

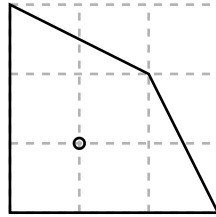

One can check that the generic  $\mathbb{Q}$ -Gorenstein deformation of  $X_P$  is  $X_{2,8/3}$ . Kasprzyk

and Tveiten [KT] have shown that the affine space  $\mathbf{L}^T(P)$  is the 2-parameter family

$$f_{a,b}(x, y) = xy + by + \frac{y^2}{x} + 3\frac{y}{x} + \frac{3}{x} + \frac{1}{xy} + \frac{3}{y} + 3\frac{x}{y} + \frac{x^2}{y} + ax$$

as  $a, b \in \mathbb{Q}$ . We can check that the classical period of  $f_{a,a}$  coincides with  $\widehat{G}_{\mathcal{X}}(a, a; t)$ .

#### 2.4.4. Another example of a toric complete intersection: $B_{1,16/3}$

Let  $\mathcal{X}$  be a general quartic in  $\mathcal{Y} = \mathbb{P}(1, 1, 1, 3)$ . In this example we apply the Quantum Lefschetz technique, as in the §2.4.3, to compute the quantum period of  $\mathcal{X}$ . Nevertheless, here it is crucial to use Conjecture 2.18 by applying  $\iota^*$  firstly and then considering the limit for  $\kappa \rightarrow 0$ .

The reason is that, since the toric ambient  $\mathcal{Y}$  is ‘extended weak Fano’, it is impossible to choose a lifting of  $\mathcal{E} = \mathcal{O}_{\mathcal{Y}}(4)$  to the extended Picard group in such a way that the extended twisted I-function  $I_{\mathcal{E}}^S$  has both a good asymptotic behaviour with respect to  $z$  and a well-defined non-equivariant limit for  $\kappa \rightarrow 0$ . So we will choose a lifting of  $\mathcal{E}$  such that  $I_{\mathcal{E}}^S$  has a good asymptotic behaviour, but  $\lim_{\kappa \rightarrow 0} I_{\mathcal{E}}^S$  does not exist. Fortunately, even though  $I_{\mathcal{E}}^S$  does not have a well-defined limit as  $\kappa \rightarrow 0$ ,  $\iota^* I_{\mathcal{E}}^S$  does:  $\iota^* I_{\mathcal{E}}^S \rightarrow I_{\mathcal{X}, \mathcal{Y}}$  as  $\kappa \rightarrow 0$ . Having a good asymptotic behaviour,  $I_{\mathcal{X}, \mathcal{Y}}$  gives information about  $J_{\mathcal{X}}$ .

It is easy to see that  $[0 : 0 : 0 : 1]$  is the unique singular point of  $Y$  and is of type  $\frac{1}{3}(1, 1, 1)$ . The inertia stack  $\mathbf{I}\mathcal{Y}$  has three connected components: one isomorphic to  $\mathcal{Y}$  and two non-trivial components which are both isomorphic to  $\mathbf{B}\mu_3$ . Since  $-K_X = \mathcal{O}_X(2)$ ,  $X$  is a del Pezzo surface with Fano index 2 and degree  $K_X^2 = 2 \cdot 2 \cdot 4 \cdot \frac{1}{3} = \frac{16}{3}$ . Moreover  $[0 : 0 : 0 : 1]$  is the unique singular point of  $X$  and is of type  $\frac{1}{3}(1, 1)$ . Therefore  $X$  has been called  $B_{1,16/3}$  in [CH17].

The fan sequence (2.5) of  $\mathcal{Y}$  is

$$0 \longrightarrow \mathbb{L} \simeq \mathbb{Z} \longrightarrow \mathbb{Z}^4 \xrightarrow{\rho} \mathbb{Z}^3 = N \longrightarrow 0$$

where

$$\rho = \begin{pmatrix} -1 & 1 & 0 & 0 \\ -1 & 0 & 1 & 0 \\ -3 & 0 & 0 & 1 \end{pmatrix}.$$

The divisor matrix is

$$D = \begin{pmatrix} 1 & 1 & 1 & 3 \end{pmatrix}.$$

We use the transpose of  $D$  as a basis of  $\mathbb{L}$ . One can check that

$$\text{Box}(\mathcal{Y}) = \{(0, 0, 0), (0, 0, -1), (0, 0, -2)\},$$

with ages 0, 1, 2 respectively.

Now we extend with  $(0, 0, -1)$ . The extended fan sequence (2.9) is

$$0 \longrightarrow \mathbb{L}^S \simeq \mathbb{Z}^2 \xrightarrow{tD^S} \mathbb{Z}^5 \xrightarrow{\rho^S} \mathbb{Z}^3 = N \longrightarrow 0,$$

where

$$\rho^S = \begin{pmatrix} -1 & 1 & 0 & 0 & 0 \\ -1 & 0 & 1 & 0 & 0 \\ -3 & 0 & 0 & 1 & -1 \end{pmatrix} \quad \text{and} \quad D^S = \begin{pmatrix} 1 & 1 & 1 & 3 & 0 \\ 0 & 0 & 0 & 1 & 1 \end{pmatrix}.$$

The extended nef cone is

$$\text{Nef}^S(\mathcal{Y}) = \text{cone} \left\langle \begin{pmatrix} 3 \\ 1 \end{pmatrix}, \begin{pmatrix} 0 \\ 1 \end{pmatrix} \right\rangle.$$

Let us use coordinates  $(l, k)$  on  $\mathbb{L}^S$  given by the basis made up of the rows of  $D^S$ . One can check that

$$\Lambda E^S = \left\{ (l, l, l, 3l + k, k) \in \mathbb{Q}^5 \mid \begin{array}{l} l \in \frac{1}{3}\mathbb{Z}, k \in \mathbb{Z}, \\ 3l + k \geq 0, k \geq 0 \end{array} \right\}.$$

The reduction function  $v^S: \Lambda E^S \rightarrow \text{Box}(\mathcal{Y})$  is given by  $v^S(l, k) = 3\langle -l \rangle (0, 0, -1)$ . Since  $s_1 = \frac{1}{3}(\rho_1 + \rho_2 + \rho_3)$ , the projection in  $\mathbb{L} \otimes_{\mathbb{Z}} \mathbb{Q}$  of  $(l, k) \in \mathbb{L}^S \otimes_{\mathbb{Z}} \mathbb{Q}$  via the splitting (2.11) is  $d = l + \frac{k}{3}$ .

Let  $p$  be the first Chern class of  $\mathcal{O}_{\mathcal{Y}}(1)$ . In order to write down a twisted  $S$ -extended I-function, we have to choose a lifting  $(4, \alpha)$  of  $4p \in \mathbb{L}^{\vee}$  to  $\mathbb{L}^{S\vee}$ . One can check that  $I_{\mathcal{E}}^S$  has a good asymptotic behaviour if and only if  $(2, 2 - \alpha) \in \text{Nef}^S(\mathcal{Y})$ , i.e.  $\alpha \leq 1$ . On the other hand,  $\lim_{\kappa \rightarrow 0} I_{\mathcal{E}}^S$  exists if and only if  $(4, \alpha) \in \text{Nef}^S(\mathcal{Y})$ , i.e.  $\alpha \geq 2$ . Therefore, it is impossible to find an  $\alpha \in \mathbb{Z}$  such that  $I_{\mathcal{E}}^S$  has a good asymptotic behaviour and that the non-equivariant limit of  $I_{\mathcal{E}}^S$  exists. This is related to the fact that the extended anticanonical class  $(6, 2)$  is not in the interior of  $\text{Nef}^S(\mathcal{Y})$ , i.e.  $\mathcal{Y}$  is not ‘extended Fano’, but only ‘extended weak Fano’.

Now we fix  $\alpha = 1$ . Consider the summand

$$\square_{l,k} = \left( \frac{\prod_{\substack{a \leq 0 \\ \langle a \rangle = \langle l \rangle}} (p + az)}{\prod_{\substack{a \leq l \\ \langle a \rangle = \langle l \rangle}} (p + az)} \right)^3 \frac{1}{\prod_{\substack{0 < a \leq 3l+k \\ \langle a \rangle = \langle 3l+k \rangle}} (3p + az)} \frac{1}{k! z^k} \frac{\prod_{\substack{a \leq 4l+k \\ \langle a \rangle = \langle 4l+k \rangle}} (4p + \kappa + az)}{\prod_{\substack{a \leq 0 \\ \langle a \rangle = \langle 4l+k \rangle}} (4p + \kappa + az)}$$

of  $I_{\mathcal{E}}^S$  corresponding to  $(l, k) \in \Lambda E^S$ . We see that the degree of  $\square_{l,k}$  with respect to  $z$  is the following:

$$\begin{aligned} \deg \square_{l,k} &= -3 \cdot \begin{cases} [l] + 1 & \text{if } l \in \mathbb{Z}, l < 0 \\ [l] & \text{if } l \notin \mathbb{Z} \text{ or } l \geq 0 \end{cases} - [3l + k] - k + \\ &+ \begin{cases} [4l + k] + 1 & \text{if } 4l + k \in \mathbb{Z}, 4l + k < 0 \\ [4l + k] & \text{if } 4l + k \notin \mathbb{Z} \text{ or } 4l + k \geq 0 \end{cases} \\ &= \begin{cases} -2[l] - k & \text{if } l \notin \mathbb{Z} \text{ or } l \geq 0; \\ -2l - k - 3 & \text{if } l \in \mathbb{Z}, -\frac{k}{4} \leq l < 0; \\ -2l - k - 2 & \text{if } l \in \mathbb{Z}, l < -\frac{k}{4}. \end{cases} \end{aligned}$$

It is easy to show that  $(-\frac{1}{3}, 1)$  is the only  $(l, k) \in \Lambda E^S$  such that  $\deg \square_{l,k} \geq -1$ . So the twisted I-function of  $\mathcal{Y}$  has the following asymptotic behaviour:

$$I_{\mathcal{E}}^S(\tau, \xi, z) = z \mathbf{1}_0 + \tau p + \tilde{Q}^{(0,1)} \mathbf{1}_0 + \xi \mathbf{1}_{(0,0,-1)} + O(z^{-1}).$$

The lifting we have chosen is not in  $\text{Nef}^S$ , hence the non-equivariant limit of  $I_{\mathcal{E}}^S$  does not exist.

However, we can study the pull-back  $\iota^*(I_{\mathcal{E}}^S)$  more carefully. The terms  $\square_{l,k}$  that are divisible by  $\kappa^{-1}$ , namely the ones that prevents the existence of the limit, correspond to  $(l, k)$  such that  $4l + k \in \mathbb{Z}_{<0}$ ; in these cases we have that  $\square_{l,k}$  is divisible by  $p^3$  and then, since  $\mathcal{X}$  is a surface,  $\iota^*(\square_{l,k}) = 0$ . Therefore the limit

$$I_{\mathcal{X}, \mathcal{Y}} := \lim_{\kappa \rightarrow 0} \iota^* I_{\mathcal{E}}^S$$

exists and, according to Conjecture 2.18, lies in  $\mathcal{L}_{\mathcal{X}}$ . Thus, the J-function of  $\mathcal{X}$  is such that

$$J_{\mathcal{X}}(\tau p + \xi \mathbf{1}_{1/3}; z) = \exp \left( -\frac{\tilde{Q}^{(0,1)} \mathbf{1}_0}{z} \right) I_{\mathcal{X}, \mathcal{Y}}.$$

After applying the change of variables  $\tilde{Q}^{(l,k)} \mapsto x^k t^{2l+k}$ , we get

$$G_{\mathcal{X}}(x; t) = \exp(-xt) \sum_{l,k \in \mathbb{N}} \frac{(4l+k)!}{l!^3 (3l+k)! k!} x^k t^{2l+k}.$$

The regularised quantum period is

$$\widehat{G}_{\mathcal{X}}(x; t) = 1 + 8t^2 + 6xt^3 + 168t^4 + 240xt^5 + (4440 + 90x)t^6 + 9240xt^7 + \dots.$$

On the other hand, we consider the Fano polygon  $P$  whose vertices are the columns of

$$\begin{pmatrix} 1 & -1 & -1 \\ 1 & 2 & -2 \end{pmatrix}.$$

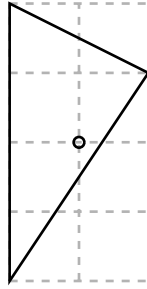

One can check that the generic  $\mathbb{Q}$ -Gorenstein deformation of  $X_P$  is  $B_{1,16/3}$ . Kasprzyk and Tveiten [KT] have shown that the affine space  $\mathbf{L}^T(P)$  is the 1-parameter family

$$f_a(x, y) = \frac{(1+y)^4}{xy^2} + yx + ay$$

as  $a \in \mathbb{Q}$ . We can check that the classical period of  $f_a$  coincides with  $\widehat{G}_{\mathcal{X}}(a; t)$ .

## 2.5. The Abelian/non-Abelian Correspondence

### 2.5.1. Theoretical background

Let  $G$  be a reductive group over  $\mathbb{C}$  acting on a smooth affine variety  $A$ . Let  $T$  be a maximal torus in  $G$ . We consider the stack-theoretic GIT quotients  $[A//G]$  and  $[A//T]$ . Let  $E$  be a representation of  $G$  and let  $\mathcal{E}_G$  and  $\mathcal{E}_T$  be the induced vector bundles on  $[A//G]$  and  $[A//T]$ , respectively. We assume that  $[A//G]$  and  $[A//T]$  are proper Deligne–Mumford stacks with projective coarse moduli spaces. Moreover, we assume that there are no strictly semi-stable points and the unstable

locus has codimension at least 2, for both the actions of  $G$  and  $T$ . The Abelian/non-Abelian Correspondence of Bertram, Ciocan-Fontanine, Kim and Sabbah [BCFK08, CFKS08] relates<sup>4</sup> genus-zero Gromov–Witten invariants of  $[A//G]$ , twisted by  $\mathcal{E}_G$ , to the Gromov–Witten invariants of  $[A//T]$ , twisted by  $\mathcal{E}_T$ . We will be more precise below.

Let  $W = N(T)/T$  be the Weyl group and  $\Phi = \Phi_+ \cup \Phi_-$  be the root system with decomposition into positive and negative roots. The adjoint  $T$ -representation  $\mathfrak{g}$  splits as  $\mathfrak{g} = \mathfrak{t} \oplus \bigoplus_{\alpha \in \Phi} \mathfrak{g}_\alpha$ . For every  $\alpha \in \Phi$ , the one-dimensional  $T$ -representation  $\mathfrak{g}_\alpha$  induces a line bundle  $L_\alpha$  on  $[A//T]$ . Let  $p_\alpha = c_1(L_\alpha)$  and consider

$$\omega := \prod_{\alpha \in \Phi_+} p_\alpha.$$

It is the fundamental  $W$ -anti-invariant class in the cohomology of  $[A//T]$ . We recall that the  $W$ -invariant part of the cohomology of  $[A//T]$  may be identified with the cohomology of  $[A//G]$ .

There are homomorphisms  $\text{Pic}([A//G]) \hookrightarrow \text{Pic}([A//T])$  and  $\rho: \text{Eff}([A//T]) \rightarrow \text{Eff}([A//G])$ . The homomorphism  $\varepsilon: \text{Eff}([A//G]) \rightarrow \mathbb{Q}$  sends a curve class  $\beta$  into  $\sum_{\alpha \in \Phi_+} L_\alpha \cdot \tilde{\beta}$ , where  $\tilde{\beta} \in \text{Eff}([A//T])$  is a preimage of  $\beta$ . We consider the homomorphism on the Novikov rings  $p: \Lambda_{[A//T]} \rightarrow \Lambda_{[A//G]}$  defined by  $p(Q^d) = (-1)^{\varepsilon(\rho(d))} Q^{\rho(d)}$ , for every  $d \in \text{Eff}([A//T])$ .<sup>5</sup>

**Conjecture 2.23** (Abelian/non-Abelian Correspondence). *Let  $J^{\mathcal{E}_G}$  and  $J^{\mathcal{E}_T}$  be the  $J$ -functions for the corresponding twisted Gromov–Witten theories of  $[A//G]$  and  $[A//T]$  (as in §2.4.1), respectively. Consider the differential operator  $\mathcal{D} = z\partial_\omega$ . Let  $\tilde{J}$  be the  $W$ -invariant function such that  $\mathcal{D}J^{\mathcal{E}_T} = \omega \cup \tilde{J}$ .*

*Then  $\tilde{J}$  coincides with  $J^{\mathcal{E}_G}$ , after:*

- *identifying the  $W$ -invariant part of the cohomology of  $[A//T]$  with the cohomology of  $[A//G]$ ;*
- *applying the homomorphism  $p$  on the Novikov ring of  $[A//T]$ ;*
- *applying a suitable mirror map  $\phi$  on the parameters:*

$$\mathcal{D}J^{\mathcal{E}_T}(\gamma; z) \Big|_{Q^d \mapsto p(Q^d)} = \omega \cup \tilde{J}(\phi(\gamma); z).$$

<sup>4</sup>The results of [CFKS08] have a projective hypothesis on  $A$ , but their arguments apply verbatim to the case where  $A$  is affine, as here.

<sup>5</sup>This actually depends on the choice of an  $m$ th root of  $-1$ , where  $m$  is the least common multiple of the exponents of the automorphism group of geometric points of  $[A//G]$ .

In [CFKS08, Theorem 6.1.2] Ciocan-Fontanine, Kim and Sabbah state Conjecture 2.23 under the additional assumption that  $[A//T]$  and  $[A//G]$  are smooth varieties and show that it is a consequence of a conjecture about Frobenius structures. Moreover, in [CFKS08, Theorem 4.1.1] they show that Conjecture 2.23 holds when  $[A//G]$  is a flag manifold. In §2.5.2 we show how to use Conjecture 2.23 for our computations.

### 2.5.2. Example of Abelian/non-Abelian correspondence: $X_{1,7/3}$

Let  $A$  be the space of  $2 \times 5$  matrices, which are denoted by

$$\begin{pmatrix} a_1 & a_2 & a_3 & a_4 & a_5 \\ b_1 & b_2 & b_3 & b_4 & b_5 \end{pmatrix}.$$

The group  $\mathrm{SL}_2$  acts on  $A$  via left multiplication and the group  $\mathbb{G}_m$  acts on  $A$  via

$$\mu \cdot \begin{pmatrix} a_1 & a_2 & a_3 & a_4 & a_5 \\ b_1 & b_2 & b_3 & b_4 & b_5 \end{pmatrix} = \begin{pmatrix} \mu a_1 & \mu a_2 & \mu a_3 & \mu^3 a_4 & \mu^3 a_5 \\ \mu b_1 & \mu b_2 & \mu b_3 & \mu^3 b_4 & \mu^3 b_5 \end{pmatrix}.$$

We get an action of  $\mathrm{SL}_2 \times \mathbb{G}_m$  on  $A$ , which induces a faithful action of the affine reductive group

$$G := (\mathrm{SL}_2 \times \mathbb{G}_m) / \left\{ \left( \begin{pmatrix} \lambda & 0 \\ 0 & \lambda \end{pmatrix}, \lambda \right) \mid \lambda \in \mu_2 \right\}$$

on  $A$ . Following [CR02, Example 2.6], the stack-theoretic GIT quotient  $\mathcal{F} := [A//G]$  is the weighted Grassmannian  $\mathrm{wGr}(2, 5)$  with weights  $\frac{1}{2}, \frac{1}{2}, \frac{1}{2}, \frac{3}{2}, \frac{3}{2}$ . By using

$$c_{ij} = \det \begin{pmatrix} a_i & a_j \\ b_i & b_j \end{pmatrix}, \quad 1 \leq i < j \leq 5$$

as coordinates, we get a closed embedding of  $\mathcal{F}$  into the weighted projective space  $\mathbb{P} = \mathbb{P}(1^3, 2^6, 3)$ . The pulling-back homomorphism  $\mathbb{Z} \simeq \mathrm{Pic}(\mathbb{P}) \rightarrow \mathrm{Pic}(\mathcal{F})$  maps  $\mathcal{O}_{\mathbb{P}}(1)$  into the line bundle  $\mathcal{O}_{\mathcal{F}}(1)$  on  $\mathcal{F}$  associated to the character of  $G$  induced by the composite

$$\mathrm{SL}_2 \times \mathbb{G}_m \xrightarrow{\mathrm{pr}_2} \mathbb{G}_m \xrightarrow{(\cdot)^2} \mathbb{G}_m.$$

Let  $\mathcal{X} \hookrightarrow \mathcal{F}$  be the zero locus of a generic section of  $\mathcal{E}_G = \mathcal{O}_{\mathcal{F}}(2)^{\oplus 4}$ . The coarse moduli space  $X$  of  $\mathcal{X}$  is a del Pezzo surface with one  $\frac{1}{3}(1, 1)$  and degree  $K_X^2 = \frac{7}{3}$  (see [CH17]). To compute the Gromov–Witten invariants of  $\mathcal{X}$  we need to compute the  $\mathcal{E}_G$ -twisted Gromov–Witten invariants of  $\mathcal{F}$ . This can be done by using Conjecture



2.23.

We consider the maximal subtorus of  $G$

$$T := \left\{ \left( \begin{pmatrix} \lambda & 0 \\ 0 & \lambda^{-1} \end{pmatrix}, \mu \right) \middle| \lambda, \mu \in \mathbb{G}_m \right\} / \left\{ \left( \begin{pmatrix} \lambda & 0 \\ 0 & \lambda \end{pmatrix}, \lambda \right) \middle| \lambda \in \mu_2 \right\},$$

which is isomorphic to  $\mathbb{G}_m^2$  via

$$\left( \begin{pmatrix} \lambda & 0 \\ 0 & \lambda^{-1} \end{pmatrix}, \mu \right) \mapsto (\lambda\mu, \lambda^{-1}\mu).$$

Therefore the toric Fano orbifold  $\mathcal{Y} := [A//T]$  is the stack-theoretic GIT quotient of  $A \simeq \mathbb{A}^{10}$  with respect to the action of  $\mathbb{G}_m^2$  given by the following matrix.

$$\begin{array}{cccccccccc} a_1 & a_2 & a_3 & a_4 & a_5 & b_1 & b_2 & b_3 & b_4 & b_5 \\ 1 & 1 & 1 & 2 & 2 & 0 & 0 & 0 & 1 & 1 \\ 0 & 0 & 0 & 1 & 1 & 1 & 1 & 1 & 2 & 2 \end{array}$$

Let  $Y$  be the coarse moduli space of  $\mathcal{Y}$ . We denote by  $p_1, p_2 \in H^2(Y; \mathbb{Q})$  the first Chern classes of the line bundles on  $\mathcal{Y}$  induced by the characters of  $T$  given by

$$\left( \begin{pmatrix} \lambda & 0 \\ 0 & \lambda^{-1} \end{pmatrix}, \mu \right) \mapsto \lambda\mu \quad \text{and} \quad \left( \begin{pmatrix} \lambda & 0 \\ 0 & \lambda^{-1} \end{pmatrix}, \mu \right) \mapsto \lambda^{-1}\mu.$$

The nef cone of  $Y$  is  $\text{Nef}(Y) = \text{cone} \langle 2p_1 + p_2, p_1 + 2p_2 \rangle$ . Let  $\mathcal{O}_{\mathcal{Y}}(1)$  be the line bundle on  $\mathcal{Y}$  such that its restriction to  $[A^s(G)/T]$  is the pull-back of  $\mathcal{O}_{\mathcal{F}}(1)$  from  $\mathcal{F} = [A^s(G)/G]$ ; it corresponds to the character of  $T$  defined by

$$\left( \begin{pmatrix} \lambda & 0 \\ 0 & \lambda^{-1} \end{pmatrix}, \mu \right) \mapsto \mu^2.$$

Therefore  $c_1(\mathcal{O}_{\mathcal{Y}}(1)) = p_1 + p_2$ , which is ample. Consider the vector bundle  $\mathcal{E}_T = \mathcal{O}_{\mathcal{Y}}(2)^{\oplus 4}$ .

Since  $\mathcal{Y}$  is a toric orbifold, we may construct its  $\mathcal{E}_T$ -twisted I-function:

$$\begin{aligned} I^{\mathcal{E}_T}(\tau_1, \tau_2; z) &= ze^{(\tau_1 p_1 + \tau_2 p_2)/z} \sum_{(l_1, l_2) \in \Lambda E} Q^{(l_1, l_2)} e^{\tau_1 l_1 + \tau_2 l_2} \square_{l_1, l_2} \mathbf{1}_{v(l_1, l_2)} \\ &= \sum_{(l_1, l_2) \in \Lambda E} z Q^{(l_1, l_2)} \exp \left( \left( l_1 + \frac{p_1}{z} \right) \tau_1 + \left( l_2 + \frac{p_2}{z} \right) \tau_2 \right) \square_{l_1, l_2} \mathbf{1}_{v(l_1, l_2)}. \end{aligned}$$

where

$$\begin{aligned} \square_{l_1, l_2} = & \left( \frac{\prod_{\substack{a \leq 0 \\ \langle a \rangle = \langle l_1 \rangle}} (p_1 + az)}{\prod_{\substack{a \leq l_1 \\ \langle a \rangle = \langle l_1 \rangle}} (p_1 + az)} \right)^3 \left( \frac{\prod_{\substack{a \leq 0 \\ \langle a \rangle = \langle 2l_1 + l_2 \rangle}} (2p_1 + p_2 + az)}{\prod_{\substack{a \leq 2l_1 + l_2 \\ \langle a \rangle = \langle 2l_1 + l_2 \rangle}} (2p_1 + p_2 + az)} \right)^2 \left( \frac{\prod_{\substack{a \leq 0 \\ \langle a \rangle = \langle l_2 \rangle}} (p_2 + az)}{\prod_{\substack{a \leq l_2 \\ \langle a \rangle = \langle l_2 \rangle}} (p_2 + az)} \right)^3 \times \\ & \times \left( \frac{\prod_{\substack{a \leq 0 \\ \langle a \rangle = \langle l_1 + 2l_2 \rangle}} (p_1 + 2p_2 + az)}{\prod_{\substack{a \leq l_1 + 2l_2 \\ \langle a \rangle = \langle l_1 + 2l_2 \rangle}} (p_1 + 2p_2 + az)} \right)^2 \left( \prod_{\substack{0 < a \leq 2l_1 + 2l_2 \\ \langle a \rangle = \langle 2l_1 + 2l_2 \rangle}} (2p_1 + 2p_2 + az) \right)^4 \end{aligned}$$

One may prove that

$$I^{\mathcal{E}_T} = z\mathbf{1}_0 + 4(Q^{(1,0)}e^{\tau_1} + Q^{(0,1)}e^{\tau_2})\mathbf{1}_0 + \tau_1 p_1 + \tau_2 p_2 + \varphi(\tau_1, \tau_2)\mathbf{1}_b + O(z^{-1}),$$

where

$$\varphi(\tau_1, \tau_2) = \frac{2}{3} \left( Q^{(-\frac{1}{3}, \frac{2}{3})} e^{\frac{-\tau_1 + 2\tau_2}{3}} + Q^{(\frac{2}{3}, -\frac{1}{3})} e^{\frac{2\tau_1 - \tau_2}{3}} \right)$$

and  $b \in \text{Box}(\mathcal{Y})$  is a component with  $\text{age}(b) = 2$ . Therefore, the  $\mathcal{E}_T$ -twisted J-function of  $\mathcal{Y}$  is such that

$$J^{\mathcal{E}_T}(\tau_1 p_1 + \tau_2 p_2 + \varphi(\tau_1, \tau_2)\mathbf{1}_b; z) = \exp\left(-4 \frac{Q^{(1,0)}e^{\tau_1} + Q^{(0,1)}e^{\tau_2}}{z}\right) \cdot I^{\mathcal{E}_T}. \quad (2.16)$$

The Weyl group  $W = N(T)/T$  of  $G$  is cyclic of order 2 and is generated by the class of

$$\left( \left( \begin{pmatrix} 0 & 1 \\ -1 & 0 \end{pmatrix}, 1 \right) \right).$$

The positive root  $\alpha$  corresponds to the character of  $T$  defined by

$$\left( \left( \begin{pmatrix} \lambda & 0 \\ 0 & \lambda^{-1} \end{pmatrix}, \mu \right) \right) \mapsto \lambda^2.$$

This character of  $T$  induces the line bundle  $L_\alpha$  on  $\mathcal{Y}$ . Let  $\omega = c_1(L_\alpha) = p_1 - p_2$ . Consider the differential operator  $\mathcal{D} = z\partial_{p_1 - p_2}$ . Since  $J^{\mathcal{E}_T}$  is  $W$ -invariant,  $\mathcal{D}J^{\mathcal{E}_T}$  is  $W$ -anti-invariant and must be divisible by  $\omega = p_1 - p_2$ :

$$\mathcal{D}J^{\mathcal{E}_T} = (p_1 - p_2) \cup \tilde{J}.$$

The Abelian/non-Abelian Correspondence (Conjecture 2.23) relates  $\tilde{J}$  with a lifting of the  $\mathcal{E}_G$ -twisted J-function of  $\mathcal{F}$ , up to the ring homomorphism on the Novikov

rings  $Q^{(l_1, l_2)} \mapsto (-q)^{l_1 + l_2}$ .

Unfortunately we do not know  $J^{\mathcal{E}T}$ , but by (2.16) we only know  $J^{\mathcal{E}T} \circ \vartheta$ , where  $\vartheta: (\tau_1, \tau_2) \mapsto \tau_1 p_1 + \tau_2 p_2 + \varphi(\tau_1, \tau_2) \mathbf{1}_b$ . Now consider the differential operator  $\overline{\mathcal{D}} = z(\partial_{\tau_1} - \partial_{\tau_2})$ . By the chain rule, we get

$$(\mathcal{D}J^{\mathcal{E}T})(\vartheta(\tau_1, \tau_2)) = \overline{\mathcal{D}}(J^{\mathcal{E}T} \circ \vartheta) - z\partial_{\mathbf{1}_b} J^{\mathcal{E}T}(\vartheta(\tau_1, \tau_2)) \cdot (\partial_{\tau_1} \varphi - \partial_{\tau_2} \varphi),$$

where

$$\partial_{\tau_1} \varphi - \partial_{\tau_2} \varphi = \frac{2}{3} \left( -Q^{(-\frac{1}{3}, \frac{2}{3})} e^{-\frac{\tau_1 + 2\tau_2}{3}} + Q^{(\frac{2}{3}, -\frac{1}{3})} e^{\frac{2\tau_1 - \tau_2}{3}} \right)$$

From (2.16), we get

$$\overline{\mathcal{D}}(J^{\mathcal{E}T} \circ \vartheta) = \exp \left( -4 \frac{Q^{(1,0)} e^{\tau_1} + Q^{(0,1)} e^{\tau_2}}{z} \right) [-4(Q^{(1,0)} e^{\tau_1} - Q^{(0,1)} e^{\tau_2}) I^{\mathcal{E}T} + \overline{\mathcal{D}} I^{\mathcal{E}T}],$$

where

$$\begin{aligned} \overline{\mathcal{D}} I^{\mathcal{E}T} &= \sum_{(l_1, l_2) \in \Lambda E} z Q^{(l_1, l_2)} \exp \left( \left( l_1 + \frac{p_1}{z} \right) \tau_1 + \left( l_2 + \frac{p_2}{z} \right) \tau_2 \right) \times \\ &\quad \times (z l_1 + p_1 - z l_2 - p_2) \square_{l_1, l_2} \mathbf{1}_{v(l_1, l_2)}. \end{aligned}$$

If we set  $Q^{(l_1, l_2)} = (-q)^{l_1 + l_2}$ , we get

$$\begin{aligned} \mathcal{D}J^{\mathcal{E}T}(\vartheta(0, 0)) &= \overline{\mathcal{D}}(J^{\mathcal{E}T} \circ \vartheta)|_{\tau_1 = \tau_2 = 0} \\ &= e^{8qz^{-1}} \sum_{(l_1, l_2) \in \Lambda E} z (-q)^{l_1 + l_2} (z l_1 + p_1 - z l_2 - p_2) \square_{l_1, l_2} \mathbf{1}_{v(l_1, l_2)}, \end{aligned}$$

whose asymptotic behaviour is

$$\mathcal{D}J^{\mathcal{E}T}(\vartheta(0, 0)) = (p_1 - p_2) \left( z + 16q \mathbf{1}_0 + \frac{25}{9} (-q)^{\frac{1}{3}} \mathbf{1}_b + O(z^{-1}) \right).$$

Hence, Conjecture 2.23 implies that a specialisation of  $J^{\mathcal{E}G}$  coincides with  $e^{-16qz^{-1}} \tilde{J}$ , via the string equation. Its component along the identity class  $\mathbf{1}_0$  is

$$e^{-8qz^{-1}} \sum_{l_1, l_2 \in \mathbb{N}} A_{l_1, l_2}(q, z) \left( 1 + \frac{l_1 - l_2}{2} (-3H_{l_1} + 3H_{l_2} - 2H_{2l_1 + l_2} + 2H_{2l_2 + l_1}) \right)$$

where  $H_l := \sum_{i=1}^l \frac{1}{i}$  is the  $l$ th harmonic number ( $H_0 := 0$ ) and

$$A_{l_1, l_2}(q, z) := (-q)^{l_1 + l_2} \frac{(2l_1 + 2l_2)!^4}{l_1!^3 l_2!^3 (2l_1 + l_2)!^2 (l_1 + 2l_2)!^2 z^{l_1 + l_2 - 1}}.$$

Therefore a specialisation of the quantum period of  $\mathcal{X}$  is

$$G(t) = \exp(-8t) \sum_{l_1, l_2 \in \mathbb{N}} A_{l_1, l_2}(t, 1) \left( 1 + \frac{l_1 - l_2}{2} (-3H_{l_1} + 3H_{l_2} - 2H_{2l_1 + l_2} + 2H_{2l_2 + l_1}) \right),$$

whose regularization is

$$\widehat{G}(t) = 1 + 112t^2 + 1650t^3 + 48048t^4 + \dots$$

On the other hand, let  $P$  be the Fano polygon whose vertices are the columns of the matrix

$$\begin{pmatrix} 1 & -1 & -1 & 1 \\ 1 & 2 & -2 & -2 \end{pmatrix}.$$

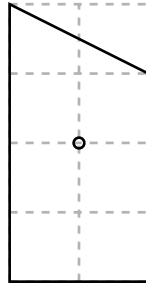

One can show that the generic  $\mathbb{Q}$ -Gorenstein deformation of  $X_P$  is  $X_{1,7/3}$ . Kasprzyk and Tveiten [KT] have proven that  $\mathbf{L}^T(P)$  is the 1-parameter family

$$f_a(x, y) = ay + \frac{x}{y^2}(1+y)^3 + \frac{1}{xy^2}(1+y)^4 + \frac{7}{y} + \frac{2}{y^2}.$$

One can check that the classical period of  $f_3$  is  $\widehat{G}(t)$ .

# 3

## Homogeneous deformations of toric varieties

In this chapter, after recalling some facts in toric geometry (§3.1), we explain Mavlyutov's construction of deformations of affine toric varieties in §3.2. In §3.3 we give a generalisation to affine toric pairs. In §3.4 we consider deformations of polarised projective toric varieties. Finally, in §3.5 we give an explicit formulation of the fact, due to Ilten, that two mutation equivalent Fano polytopes give deformation equivalent toric Fano varieties.

### 3.1. Preliminaries on toric geometry

For generalities about toric varieties we refer the reader to [Ful93] and [CLS11]. We firstly treat toric schemes, with split tori, which are defined over arbitrary rings and consider their total coordinate rings.

**Remark 3.1** (Toric schemes over arbitrary rings). Let  $A$  be a ring, let  $N$  be a lattice, and let  $\Sigma$  be a fan of strongly convex rational polyhedral cones in  $N_{\mathbb{R}}$ . For every cone  $\sigma \in \Sigma$ , we consider its dual  $\sigma^{\vee} \subseteq M_{\mathbb{R}}$ , the semigroup  $\sigma^{\vee} \cap M$ , and the semigroup  $A$ -algebra  $A[\sigma^{\vee} \cap M]$ . We denote by  $\mathrm{TV}_A(\Sigma)$  the scheme obtained by gluing the affine schemes  $\mathrm{TV}_A(\sigma) = \mathrm{Spec} A[\sigma^{\vee} \cap M]$  thanks to the structure of the fan  $\Sigma$ , as it is customary in toric geometry. One may prove that  $\mathrm{TV}_A(\Sigma)$  is a separated flat scheme of finite presentation over  $A$  with relative dimension  $\mathrm{rank} N$

and geometrically integral fibres. When  $A = \mathbb{C}$ ,  $\mathrm{TV}_A(\Sigma) = \mathrm{TV}_{\mathbb{C}}(\Sigma)$  is exactly the toric variety over  $\mathbb{C}$  associated to the fan  $\Sigma$  considered in [Ful93, CLS11].

Now suppose that  $N_{\mathbb{R}}$  is generated as an  $\mathbb{R}$ -vector space by the support  $|\Sigma|$  of  $\Sigma$ . In other words we assume that  $\mathrm{TV}_{\mathbb{C}}(\Sigma)$  has *no torus factors*. Let  $\Sigma(1)$  be the set of rays of  $\Sigma$ . We do not distinguish a ray of  $\Sigma$ , which is actually a 1-dimensional cone of  $\Sigma$ , from its primitive generator, which is actually the lattice point on the ray that is the closest one to the origin. Generalising the definition of Cox coordinates on toric varieties (see [Cox95], [CLS11, §5.2] or [MS05, §10]), we say that the polynomial ring  $S = A[x_{\rho} \mid \rho \in \Sigma(1)]$  is the total coordinate ring of  $\mathrm{TV}_A(\Sigma)$ . The variables  $x_{\rho}$  are called *Cox coordinates* or homogeneous coordinates. The  $A$ -algebra  $S$  has a grading with respect to the divisor class group  $G_{\Sigma} = \mathrm{Cl}(\mathrm{TV}_{\mathbb{C}}(\Sigma))$  of the variety  $\mathrm{TV}_{\mathbb{C}}(\Sigma)$ , which is a quotient of the free abelian group  $\mathbb{Z}^{\Sigma(1)}$  according to the divisor sequence of  $\Sigma$  (see [CLS11, (5.1.1)]):

$$0 \longrightarrow M \longrightarrow \mathbb{Z}^{\Sigma(1)} \longrightarrow G_{\Sigma} = \mathrm{Cl}(\mathrm{TV}_{\mathbb{C}}(\Sigma)) \longrightarrow 0.$$

For every cone  $\sigma \in \Sigma$ , setting  $x^{\hat{\sigma}} = \prod_{\rho \notin \sigma(1)} x_{\rho} \in S$ , the map defined by

$$\mathrm{Cox}: \chi^u \mapsto x^u = \prod_{\rho \in \Sigma(1)} x_{\rho}^{\langle u, \rho \rangle},$$

where  $u \in \sigma^{\vee} \cap M$  and  $\chi^u$  is the corresponding element in  $A[\sigma^{\vee} \cap M]$ , induces a ring isomorphism

$$A[\sigma^{\vee} \cap M] \simeq S_{(x^{\hat{\sigma}})} \subseteq S_{x^{\hat{\sigma}}},$$

where  $S_{x^{\hat{\sigma}}}$  is the localization of  $S$  obtained by inverting the element  $x^{\hat{\sigma}}$  and  $S_{(x^{\hat{\sigma}})}$  is the subring of the  $S_{x^{\hat{\sigma}}}$  consisting of elements of degree 0 with respect to the  $G_{\Sigma}$ -grading.

Imitating [CLS11, §5.3], from a  $G_{\Sigma}$ -graded  $S$ -module  $E$  one may construct a quasi-coherent sheaf  $\tilde{E}$  on  $\mathrm{TV}_A(\Sigma)$  such that, for every cone  $\sigma \in \Sigma$ , the sections of  $\tilde{E}$  over  $\mathrm{TV}_A(\sigma)$  are the elements of  $E_{(x^{\hat{\sigma}})}$ , i.e. the elements of degree 0 in the localization  $E_{x^{\hat{\sigma}}}$ . The assignment  $E \mapsto \tilde{E}$  is sometimes called *sheafification* and is an exact functor from the category of  $G_{\Sigma}$ -graded  $S$ -modules to the category of quasi-coherent sheaves on  $\mathrm{TV}_A(\Sigma)$ . In particular, the sheafification of a  $G_{\Sigma}$ -homogeneous ideal  $J$  of  $S$  induces a closed subscheme of  $\mathrm{TV}_A(\Sigma)$ , whose structure sheaf is the sheafification of  $S/J$ . Moreover, if  $A$  is noetherian and  $E$  is finitely generated graded  $S$ -module, then  $\tilde{E}$  is coherent on  $\mathrm{TV}_A(\Sigma)$ .

The following lemma gives a sufficient criterion to ensure the flatness of the sheafification of a graded module on a toric scheme.

**Lemma 3.2.** *Let  $N$  be a lattice and let  $\Sigma$  be a fan of strongly convex rational polyhedral cones in  $N_{\mathbb{R}}$  such that  $N_{\mathbb{R}}$  is generated by  $|\Sigma|$  as  $\mathbb{R}$ -vector space. Let  $A$  be a ring and let  $\mathrm{TV}_A(\Sigma)$  be the  $A$ -scheme constructed in Remark 3.1. Let  $S$  be the total coordinate ring of  $\mathrm{TV}_A(\Sigma)$  and let  $E$  be a graded  $S$ -module. If  $E$  is flat as an  $A$ -module, then  $\tilde{E} \in \mathrm{QCoh}(\mathrm{TV}_A(\Sigma))$  is flat over  $\mathrm{Spec} A$ .*

*Proof.* It is enough to show that  $E_{(x^{\hat{\sigma}})}$  is flat over  $A$ , for every cone  $\sigma \in \Sigma$ . The localisation  $E_{x^{\hat{\sigma}}}$  is a  $G_{\Sigma}$ -graded flat  $A$ -module and the homogeneous localisation  $E_{(x^{\hat{\sigma}})}$  is its degree zero part. Therefore,  $E_{(x^{\hat{\sigma}})}$  is a direct summand of  $E_{x^{\hat{\sigma}}}$  as  $A$ -modules and is flat over  $A$ .  $\square$

**Proposition 3.3.** *Let  $X$  be a toric variety over  $\mathbb{C}$  with no torus factors. Let  $f$  be a non-zero polynomial in the Cox coordinates of  $X$  with  $r + 1$  terms, such that it is homogeneous with respect to the  $\mathrm{Cl}(X)$ -grading. Consider the family, over  $\mathbb{P}_{\mathbb{C}}^r$ , of closed subschemes of  $X$  defined by the zero loci of the homogeneous polynomials obtained by scaling the coefficients of  $f$ . Then this family is flat over  $\mathbb{P}_{\mathbb{C}}^r$ .*

*Proof.* Let  $\Sigma$  be the fan defining  $X$ . We have  $f = b_0x^{a_0} + b_1x^{a_1} + \dots + b_rx^{a_r}$  for  $b_0, b_1, \dots, b_r \in \mathbb{C}^{\times}$  and  $a_0, \dots, a_r \in \mathbb{N}^{\Sigma(1)}$  such that  $\deg(a_0) = \dots = \deg(a_r) \in \mathrm{Cl}(X)$ . The family we are interested in is the closed subscheme  $\mathcal{Y}$  of  $X \times_{\mathrm{Spec} \mathbb{C}} \mathbb{P}_{\mathbb{C}}^r$  defined by the bihomogeneous equation

$$b_0y_0x^{a_0} + b_1y_1x^{a_1} + \dots + b_ry_rx^{a_r} = 0$$

where  $y_0, y_1, \dots, y_r$  are the homogeneous coordinates of  $\mathbb{P}_{\mathbb{C}}^r$ .

Since flatness is a local property, it is enough to restrict the family to the standard affine charts of  $\mathbb{P}_{\mathbb{C}}^r$ . For simplicity we consider  $U = \{y_0 \neq 0\} \simeq \mathbb{A}_{\mathbb{C}}^r$  only. Consider the polynomial  $\mathbb{C}$ -algebra  $A = \mathbb{C}[t_1, \dots, t_r]$  and the total coordinate ring  $S = A[x_{\rho} \mid \rho \in \Sigma(1)]$  of  $\mathrm{TV}_A(\Sigma) = X \times_{\mathrm{Spec} \mathbb{C}} \mathbb{A}_{\mathbb{C}}^r$ . The restriction of  $\mathcal{Y}$  to  $U$  is the closed subscheme of  $\mathrm{TV}_A(\Sigma)$  defined by the homogeneous ideal generated by

$$b_0x^{a_0} + b_1t_1x^{a_1} + \dots + b_rt_rx^{a_r} = 0.$$

In other words, the structure sheaf  $\mathcal{O}_{\mathcal{Y}|_U}$  of  $\mathcal{Y}|_U$  is the sheaf  $\tilde{E}$  on  $\mathrm{TV}_A(\Sigma)$  induced by the graded  $S$ -module

$$E = S/(b_0x^{a_0} + b_1t_1x^{a_1} + \dots + b_rt_rx^{a_r})S.$$

By [Mat89, Corollary of Theorem 22.6],  $E$  is flat over  $A$ . By Lemma 3.2  $\tilde{E}$  is flat over  $\mathrm{Spec} A = \mathbb{A}_{\mathbb{C}}^r$ . Therefore  $\mathcal{Y}|_U$  is flat over  $U$ .  $\square$

## 3.2. Deformations of affine toric varieties after A. Mavlyutov

In this section we recall the work [Mav] by Anvar R. Mavlyutov on the deformations of affine toric varieties and we claim no originality here. Although Mavlyutov uses Cox coordinates to generalise Altmann's construction [Alt95], his construction has the same strategy as Altmann's: starting from a Minkowski decomposition of some polyhedron (with some assumptions) one embeds the considered affine toric variety into a larger affine toric variety (Theorem 3.4(A)) and then deforms the equations of this closed embedding (Theorem 3.4(B)). More specifically, starting from a Minkowski decomposition of a polyhedron  $Q$  inside a cone  $\sigma$  one can construct a bigger cone  $\tilde{\sigma}$  and embed the toric variety associated to  $\sigma$  inside the toric variety associated to  $\tilde{\sigma}$  via binomial equations in the Cox coordinates of  $\mathrm{TV}_{\mathbb{C}}(\tilde{\sigma})$ ; by deforming these equations with extra monomials one may produce a deformation of  $\mathrm{TV}_{\mathbb{C}}(\sigma)$ . The precise statement is the following theorem of Mavlyutov. We give a detailed proof as it will be useful for our generalisation in §3.3.

**Theorem 3.4** ([Mav]). *Let  $N$  be a lattice and let  $\sigma \subseteq N_{\mathbb{R}}$  be a strongly convex rational polyhedral cone such that  $\dim \sigma = \mathrm{rank} N$ . Let  $Q, Q_0, Q_1, \dots, Q_k$  be non-empty rational polyhedra in  $N_{\mathbb{R}}$  such that:*

- (i)  $Q \subseteq \sigma$ ;
- (ii)  $0 \notin Q$ ;
- (iii)  $Q = Q_0 + Q_1 + \dots + Q_k$ ;
- (iv) for every vertex  $v \in \mathrm{vert}(Q)$ , there exist vertices  $v_0 \in \mathrm{vert}(Q_0), v_1 \in \mathrm{vert}(Q_1), \dots, v_k \in \mathrm{vert}(Q_k)$  such that  $v = v_0 + v_1 + \dots + v_k$  and

$$\#\{i \in \{0, 1, \dots, k\} \mid v_i \notin N\} \leq 1.$$

Consider the lattice  $\tilde{N} = N \oplus \mathbb{Z}e_1 \oplus \dots \oplus \mathbb{Z}e_k$  and the cone

$$\tilde{\sigma} = \mathrm{cone} \langle \sigma, Q_0 - e_1 - \dots - e_k, Q_1 + e_1, \dots, Q_k + e_k \rangle \subseteq \tilde{N}_{\mathbb{R}}.$$

(A) Then  $\tilde{\sigma}$  is a strongly convex rational polyhedral cone in  $\tilde{N}$  and the toric morphism  $\mathrm{TV}_{\mathbb{C}}(\sigma) \rightarrow \mathrm{TV}_{\mathbb{C}}(\tilde{\sigma})$ , induced by the inclusion  $N \hookrightarrow \tilde{N}$ , is a closed embedding. Moreover,  $\mathrm{TV}_{\mathbb{C}}(\sigma)$  is the closed subscheme of  $\mathrm{TV}_{\mathbb{C}}(\tilde{\sigma})$  associated to the homogeneous



ideal generated by the following binomials in the Cox coordinates of  $\mathrm{TV}_{\mathbb{C}}(\tilde{\sigma})$ :

$$\prod_{\substack{\xi \in \tilde{\sigma}(1): \\ \langle e_i^*, \xi \rangle > 0}} x_{\xi}^{\langle e_i^*, \xi \rangle} - \prod_{\substack{\xi \in \tilde{\sigma}(1): \\ \langle e_i^*, \xi \rangle < 0}} x_{\xi}^{-\langle e_i^*, \xi \rangle}$$

for  $i = 1, \dots, k$ . Moreover, these binomials form a regular sequence of length  $k$ .

(B) In addition, assume that  $w \in M$  is such that the following two conditions hold:

(v) the minimum of  $w$  on  $Q$  exists and is not smaller than  $-1$ ;

(vi) every vertex of the polyhedron  $\sigma \cap \{n \in N_{\mathbb{R}} \mid \langle w, n \rangle = -1\}$  is contained in  $\mathbb{R}^+ \cdot Q$ .

Consider

$$\tilde{w} = w - \sum_{i=1}^k \left[ \min_{Q_i} w \right] e_i^* \in \tilde{M}.$$

Let  $t_1, \dots, t_k$  be the standard coordinates on  $\mathbb{A}_{\mathbb{C}}^k$ . Consider the closed subscheme of  $\mathrm{TV}_{\mathbb{C}}(\tilde{\sigma}) \times_{\mathrm{Spec} \mathbb{C}} \mathbb{A}_{\mathbb{C}}^k = \mathrm{TV}_{\mathbb{C}[t_1, \dots, t_k]}(\tilde{\sigma})$  defined by the homogeneous ideal generated by the following trinomials in Cox coordinates:

$$\prod_{\substack{\xi \in \tilde{\sigma}(1): \\ \langle e_i^*, \xi \rangle > 0}} x_{\xi}^{\langle e_i^*, \xi \rangle} - \prod_{\substack{\xi \in \tilde{\sigma}(1): \\ \langle e_i^*, \xi \rangle < 0}} x_{\xi}^{-\langle e_i^*, \xi \rangle} - t_i \prod_{\xi \in \tilde{\sigma}(1)} x_{\xi}^{\langle \tilde{w}, \xi \rangle} \prod_{\substack{\xi \in \tilde{\sigma}(1): \\ \langle e_i^*, \xi \rangle < 0}} x_{\xi}^{-\langle e_i^*, \xi \rangle} \quad (3.1)$$

for  $i = 1, \dots, k$ . This closed subscheme induces a formal deformation of  $\mathrm{TV}_{\mathbb{C}}(\sigma)$  over  $\mathbb{C}[[t_1, \dots, t_k]]$ .

**Remark 3.5.** We will clarify what we mean when we say that the aforementioned closed subscheme induces a *formal deformation* of  $\mathrm{TV}_{\mathbb{C}}(\sigma)$  over  $\mathbb{C}[[t_1, \dots, t_k]]$ . Let  $\mathcal{X}$  be this closed subscheme, i.e. the closed subscheme of  $\mathrm{TV}_{\mathbb{C}}(\tilde{\sigma}) \times_{\mathrm{Spec} \mathbb{C}} \mathbb{A}_{\mathbb{C}}^k$  defined by the trinomials (3.1). By composing this closed immersion with the projection onto  $\mathbb{A}_{\mathbb{C}}^k$ , we get a scheme morphism  $\mathcal{X} \rightarrow \mathbb{A}_{\mathbb{C}}^k$  such that the fibre over the origin is  $\mathrm{TV}_{\mathbb{C}}(\sigma)$  by (A). We do not know if  $\mathcal{X} \rightarrow \mathbb{A}_{\mathbb{C}}^k$  is a flat morphism, but it is “formally flat” over the origin in the following sense: for every  $(t_1, \dots, t_k)$ -primary ideal  $\mathfrak{q}$  of  $\mathbb{C}[t_1, \dots, t_k]$ , the fibre product  $\mathcal{X} \times_{\mathbb{A}_{\mathbb{C}}^k} \mathrm{Spec} \mathbb{C}[t_1, \dots, t_k]/\mathfrak{q}$  is flat over  $\mathrm{Spec} \mathbb{C}[t_1, \dots, t_k]/\mathfrak{q}$ . Since the inverse limit of these  $\mathbb{C}[t_1, \dots, t_k]/\mathfrak{q}$  is  $\mathbb{C}[[t_1, \dots, t_k]]$ , we say that we have a formal deformation over  $\mathbb{C}[[t_1, \dots, t_k]]$  by using à la Schlessinger terminology.

As we will see in §3.4, if we had been dealing with deformations of complete varieties there would have been no need to specify the adverb “formally” thanks to Lemma 3.16

**Remark 3.6.** The hypotheses of Theorem 3.4 hold in the following particular case:  $w \in M$  and  $Q = \sigma \cap \{v \in N_{\mathbb{R}} \mid \langle w, v \rangle = -1\} = Q_0 + Q_1 + \cdots + Q_k$ , where  $Q_0$  is a rational polyhedron and  $Q_1, \dots, Q_k$  are lattice polyhedra. Moreover, if in addition  $Q_i \subseteq \{v \in N_{\mathbb{R}} \mid \langle w, v \rangle = 0\} =: w^\perp$  for  $i = 1, \dots, k$ , then  $\tilde{w} = w$ .

The rest of this section is devoted to the proof of Theorem 3.4 and relies entirely on [Mav].

The following lemma is a very particular case of a result by K. G. Fischer and J. Shapiro [FS96] that gives a necessary and sufficient criterion for a sequence of binomials to be a regular sequence. For every  $a \in \mathbb{Z}$ , define  $a^+ := \max\{a, 0\}$  and  $a^- := \max\{-a, 0\}$ .

**Lemma 3.7.** *Let  $\mathcal{M} = (a_{ij})_{1 \leq i \leq k, 1 \leq j \leq n}$  be a  $k \times n$  matrix with entries in  $\mathbb{Z}$ . For every  $i = 1, \dots, k$ , consider the binomial*

$$f_i = \prod_{j=1}^n x_j^{a_{ij}^+} - \prod_{j=1}^n x_j^{a_{ij}^-} \in \mathbb{C}[x_1, \dots, x_n].$$

*If the rank of  $\mathcal{M}$  is  $k$  and every column of  $\mathcal{M}$  has at most one positive entry, then  $f_1, \dots, f_k$  is a regular sequence in  $\mathbb{C}[x_1, \dots, x_n]$ .*

*Proof.* From the assumption on the rank of  $\mathcal{M}$  we deduce  $k \leq n$ . Let  $\mathcal{H}$  be the derived submatrix of  $\mathcal{M}$ . It is a  $k \times n'$  submatrix of  $\mathcal{M}$ , for some  $k \leq n' \leq n$ , such that every row of  $\mathcal{H}$  either is zero or has both a positive and negative entry and  $\mathcal{H}$  is maximal with respect to this property. We refer the reader to [FS96, p. 42] for the precise definition of the derived submatrix of  $\mathcal{M}$ . Since  $\mathcal{H}$  is obtained from  $\mathcal{M}$  by deleting some columns, also  $\mathcal{H}$  has the property that every column of  $\mathcal{H}$  has at most one positive entry.

In order to conclude that  $f_1, \dots, f_k$  is a regular sequence, we want to use [FS96, Corollary 2.4]. Therefore we need to show that  $s \leq t$  whenever there exists an  $s \times t$  submatrix of  $\mathcal{H}$  such that every row has both a positive and negative entry. This is true because of the property of  $\mathcal{H}$  above.  $\square$

When we have a cone in a lattice  $\tilde{N}$ , it is possible to intersect it with a saturated sublattice  $N$  of  $\tilde{N}$  and get a toric morphism. The following lemma describes the scheme-theoretic image of this toric morphism under some hypotheses. This will be useful in the proof of Theorem 3.4(A).

**Lemma 3.8.** *Let  $N$  be a lattice and let  $\tilde{N} = N \oplus \mathbb{Z}^k$ . Denote by  $e_1, \dots, e_k$  the standard basis of  $\mathbb{Z}^k$ . Let  $\tilde{\sigma} \subseteq \tilde{N}_{\mathbb{R}}$  be a  $(\text{rank } \tilde{N})$ -dimensional strongly convex rational*

polyhedral cone that satisfies the following condition: the  $\mathbb{Z}^k$ -component of every ray of  $\tilde{\sigma}$  has at most one positive entry, i.e.

$$\tilde{\sigma}(1) \subseteq N \times ((-\mathbb{N})^k \cup \mathbb{N}^+ e_1 \cup \dots \cup \mathbb{N}^+ e_k) \quad (3.2)$$

If  $\sigma$  is the cone  $\tilde{\sigma} \cap N_{\mathbb{R}}$  inside  $N_{\mathbb{R}}$ , then the scheme-theoretic image of the toric morphism  $\mathrm{TV}_{\mathbb{C}}(\sigma) \rightarrow \mathrm{TV}_{\mathbb{C}}(\tilde{\sigma})$  is the closed subscheme of  $\mathrm{TV}_{\mathbb{C}}(\tilde{\sigma})$  defined by the homogeneous ideal generated by the following binomials in the Cox coordinates of  $\mathrm{TV}_{\mathbb{C}}(\tilde{\sigma})$ :

$$\prod_{\substack{\xi \in \tilde{\sigma}(1): \\ \langle e_i^*, \xi \rangle > 0}} x_{\xi}^{\langle e_i^*, \xi \rangle} - \prod_{\substack{\xi \in \tilde{\sigma}(1): \\ \langle e_i^*, \xi \rangle < 0}} x_{\xi}^{-\langle e_i^*, \xi \rangle}$$

for  $i = 1, \dots, k$ . Moreover, these binomials form a regular sequence.

*Proof.* The toric morphism  $\mathrm{TV}_{\mathbb{C}}(\sigma) \rightarrow \mathrm{TV}_{\mathbb{C}}(\tilde{\sigma})$  is associated to the ring homomorphism

$$\mathbb{C}[\tilde{\sigma}^{\vee} \cap \tilde{M}] \rightarrow \mathbb{C}[\sigma^{\vee} \cap M] \quad (3.3)$$

that maps  $\chi^{\tilde{u}}$  to  $\chi^{\phi(\tilde{u})}$ , where  $\phi: \tilde{\sigma}^{\vee} \cap \tilde{M} \rightarrow \sigma^{\vee} \cap M$  is the semigroup homomorphism given by  $u + a_1 e_1^* + \dots + a_k e_k^* \mapsto u$ . Let  $I \subseteq \mathbb{C}[\tilde{\sigma}^{\vee} \cap \tilde{M}]$  be the kernel of (3.3). The scheme-theoretic image of  $\mathrm{TV}_{\mathbb{C}}(\sigma) \rightarrow \mathrm{TV}_{\mathbb{C}}(\tilde{\sigma})$  is the closed subscheme of  $\mathrm{TV}_{\mathbb{C}}(\tilde{\sigma})$  defined by the ideal  $I$ .

We consider the Cox ring of  $\mathrm{TV}_{\mathbb{C}}(\tilde{\sigma})$ :  $S = \mathbb{C}[x_{\xi} \mid \xi \in \tilde{\sigma}(1)]$ , with its  $G_{\tilde{\sigma}}$ -grading. Consider the following monomials in Cox coordinates:

$$y_i = \prod_{\substack{\xi \in \tilde{\sigma}(1): \\ \langle e_i^*, \xi \rangle > 0}} x_{\xi}^{\langle e_i^*, \xi \rangle},$$

$$z_i = \prod_{\substack{\xi \in \tilde{\sigma}(1): \\ \langle e_i^*, \xi \rangle < 0}} x_{\xi}^{-\langle e_i^*, \xi \rangle},$$

for  $i = 1, \dots, k$ . Let  $J \subseteq S$  be the ideal generated by  $y_1 - z_1, \dots, y_k - z_k$ . It is obviously homogeneous. In order to prove the thesis, we need to show that, under the Cox isomorphism between  $\mathbb{C}[\tilde{\sigma}^{\vee} \cap \tilde{M}]$  and  $S_0$ , the ideal  $I$  equals the degree zero part of the ideal  $J$ , i.e.

$$\mathrm{Cox}(I) = J \cap S_0. \quad (3.4)$$

We now prove the containment  $\subseteq$  in (3.4). Since  $I$  is the kernel of (3.3), it is not difficult to show that  $I$  is generated by the elements  $\chi^r - \chi^s$  whenever  $r, s \in \tilde{\sigma}^{\vee} \cap \tilde{M}$  are such that  $\phi(r) = \phi(s)$ . So  $r - s = \sum_{i=1}^k a_i e_i^*$ , for some  $a_i \in \mathbb{Z}$ . Now, for each  $i = 1, \dots, k$ , consider  $a_i^+ \in \mathbb{N}$  and  $a_i^- \in \mathbb{N}$ : we have  $a_i^+ a_i^- = 0$  and  $a_i = a_i^+ - a_i^-$ .

Consider the element

$$q = r - \sum_{i=1}^k a_i^+ e_i^* = s - \sum_{i=1}^k a_i^- e_i^* \in \tilde{M}.$$

Let us show that  $q \in \tilde{\sigma}^\vee$ . We need to show that  $q$  is non-negative on the rays of  $\tilde{\sigma}$ . By (3.2), we distinguish two cases:

- $v = n - b_1 e_1 - \cdots - b_k e_k \in \tilde{\sigma}(1)$ , for some  $n \in N$  and  $b_i \in \mathbb{N}$ ; then  $\langle q, v \rangle = \langle r, v \rangle + \sum_{i=1}^k a_i^+ b_i \geq \langle r, v \rangle \geq 0$ .
- $v = n + b e_i \in \tilde{\sigma}(1)$ , for some  $n \in N$ ,  $1 \leq i \leq k$  and  $b \in \mathbb{N}^+$ ; then  $\langle q, v \rangle = \langle r, v \rangle - a_i^+ b = \langle s, v \rangle - a_i^- b$ . Since either  $a_i^+ = 0$  or  $a_i^- = 0$ , we have either  $\langle q, v \rangle = \langle r, v \rangle \geq 0$  or  $\langle q, v \rangle = \langle s, v \rangle \geq 0$ .

Therefore  $\chi^q \in \mathbb{C}[\tilde{\sigma}^\vee \cap \tilde{M}]$ .

In the ring  $S$  we have the equality

$$\text{Cox}(\chi^r) \cdot \prod_{i=1}^k z_i^{a_i^+} = \text{Cox}(\chi^q) \cdot \prod_{i=1}^k y_i^{a_i^+}. \quad (3.5)$$

By (3.2) every Cox variable appearing in  $y_1 \cdots y_k$  does not appear in  $z_1 \cdots z_k$ . From (3.5) we obtain that  $\prod_{i=1}^k y_i^{a_i^+}$  divides  $\text{Cox}(\chi^r)$ . Therefore there exists a monomial  $p \in S$  such that

$$\begin{aligned} \text{Cox}(\chi^r) &= p \cdot \prod_{i=1}^k y_i^{a_i^+}, \\ \text{Cox}(\chi^q) &= p \cdot \prod_{i=1}^k z_i^{a_i^+}; \end{aligned}$$

thus the binomial

$$\text{Cox}(\chi^r - \chi^q) = p \cdot \left( \prod_{i=1}^k y_i^{a_i^+} - \prod_{i=1}^k z_i^{a_i^+} \right)$$

is clearly in the ideal  $J$ . In a completely analogous way we prove that  $\text{Cox}(\chi^s - \chi^q)$  is in  $J$ . Therefore, by taking the difference, we have that  $\text{Cox}(\chi^r - \chi^s)$  is in  $J$ .

We now prove the containment  $\supseteq$  in (3.4). Let  $f \in J \cap S_0$ . We may write

$$f = \sum_{i=1}^k f_i (y_i - z_i)$$

for some  $f_i \in S$ . Let  $\beta_i \in G_{\tilde{\sigma}}$  be the degree of  $y_i - z_i$ . By taking the homogeneous components with respect to the  $G_{\tilde{\sigma}}$ -grading, we may assume that  $f_i$  is homogeneous of degree  $-\beta_i$ . By decomposing  $f_i$  into the sum of its monomials, in order to show the containment  $\supseteq$  in (3.4), it is enough to show that  $p(y_i - z_i) \in \text{Cox}(I)$ , whenever  $i \in \{1, \dots, k\}$  and  $p \in S$  is a monomial of degree  $-\beta_i$ .

Since  $py_i$  and  $pz_i$  are monomials of degree 0 in  $S$ , there exist  $r, s \in \tilde{\sigma}^\vee \cap \tilde{M}$  such that  $py_i = \text{Cox}(\chi^r)$  and  $pz_i = \text{Cox}(\chi^s)$ . Since  $p(y_i - z_i) = \text{Cox}(\chi^r - \chi^s)$ , we must show that  $\phi(r) = \phi(s)$ . It is not difficult to show that  $\langle r - s, \xi \rangle = \langle e_i^*, \xi \rangle$  for every  $\xi \in \tilde{\sigma}(1)$ . Since  $\tilde{\sigma}$  is full dimensional, we have  $r - s = e_i^*$ ; this proves that  $\phi(r) = \phi(s)$  and  $\chi^r - \chi^s \in I$ .

Now we prove that  $y_1 - z_1, \dots, y_k - z_k$  is a regular sequence. By Lemma 3.7 it is enough to show that the matrix  $\mathcal{M} = (\langle e_i^*, \xi \rangle)_{1 \leq i \leq k, \xi \in \tilde{\sigma}(1)}$  has rank  $k$  and every column of  $\mathcal{M}$  has at most one positive entry. The latter condition is satisfied by (3.2).

The linear map associated to the matrix  $\mathcal{M}$  is the composite of the ray map  $\rho: \mathbb{Z}^{|\tilde{\sigma}(1)|} \rightarrow \tilde{N} = N \oplus \mathbb{Z}^k$  of  $\text{TV}_{\mathbb{C}}(\tilde{\sigma})$  and the projection  $\pi: \tilde{N} = N \oplus \mathbb{Z}^k \rightarrow \mathbb{Z}^k$ . Since  $\tilde{\sigma}$  is full-dimensional,  $\rho \otimes_{\mathbb{Z}} \text{id}_{\mathbb{R}}$  is surjective. This implies that  $(\pi \circ \rho) \otimes_{\mathbb{Z}} \text{id}_{\mathbb{R}}$  is surjective and that  $\mathcal{M}$  has rank  $k$ .  $\square$

*Proof of Theorem 3.4(A).* By (iii) and (i) we see that  $\text{rec}(Q_i) \subseteq \text{rec}(Q) \subseteq \sigma$  for every  $i = 0, 1, \dots, k$ . In particular,  $\text{rec}(Q_i)$  is strongly convex; so, by [CLS11, Proposition 7.1.1.b],  $Q_i = \text{conv} \langle \text{vert}(Q_i) \rangle + \text{rec}(Q_i)$ . We have that

$$\tilde{\sigma} = \text{cone} \langle \sigma, \text{vert}(Q_0) - e_1 - \dots - e_k, \text{vert}(Q_1) + e_1, \dots, \text{vert}(Q_k) + e_k \rangle.$$

This implies that the cone  $\tilde{\sigma}$  is a rational convex polyhedral cone in  $\tilde{N}$ . Moreover, the rays of  $\tilde{\sigma}$  are among the following rays:

- rays passing through the vertices of  $Q_0 - e_1 - \dots - e_k$ ;
- rays passing through the vertices of  $Q_i + e_i$ , as  $i = 1, \dots, k$ ;
- rays of  $\sigma$  that are not in the cone generated by the previous rays.

Now we prove that  $\sigma = \tilde{\sigma} \cap N_{\mathbb{R}}$ . The containment  $\subseteq$  is obvious. We need to show the containment  $\supseteq$ . Let  $\tilde{v} \in \tilde{\sigma} \cap N_{\mathbb{R}}$ . By the convexity of  $Q_0, Q_1, \dots, Q_k$ , which implies that  $\text{cone} \langle Q_i + e_i \rangle = \mathbb{R}_{\geq 0}(Q_i + e_i)$  and an analogous statement for  $Q_0$ , we

may assume that

$$\begin{aligned}\tilde{v} &= v + \lambda_0(q_0 - e_1 - \cdots - e_k) + \lambda_1(q_1 + e_1) + \cdots + \lambda_k(q_k + e_k) \\ &= v + \lambda_0 q_0 + \lambda_1 q_1 + \cdots + \lambda_k q_k + (\lambda_1 - \lambda_0)e_1 + \cdots + (\lambda_k - \lambda_0)e_k\end{aligned}$$

for some  $v \in \sigma$ ,  $q_i \in Q_i$  and  $\lambda_i \geq 0$ . Since  $\tilde{v} \in N$ ,  $\lambda_0 = \lambda_i$  for every  $i$ . Therefore  $\tilde{v} = v + \lambda_0(q_0 + q_1 + \cdots + q_k)$ . By (iii) and (i),  $q_0 + q_1 + \cdots + q_k \in Q \subseteq \sigma$  and we conclude that  $\tilde{v} \in \sigma$ .

Now we show that  $\tilde{\sigma}$  is strongly convex. Since  $\sigma$  is strongly convex and  $0 \notin Q$ , we may find  $u \in \text{int}(\sigma^\vee)$  such that  $\min_Q u > 0$ . Since the recession cones of  $Q_0, Q_1, \dots, Q_k$  are contained in  $\sigma$ , the minimum of  $u$  on each of these polyhedra exists. Consider

$$\tilde{u} = u - \sum_{i=1}^k \min_{Q_i} u e_i^* + \frac{1}{k+1} \min_Q u \sum_{i=1}^k e_i^* \in \tilde{M}_{\mathbb{R}}$$

In order to show that  $\tilde{\sigma}$  is strictly convex, we prove that  $\tilde{u}$  is positive on the rays of  $\tilde{\sigma}$ . We may distinguish three cases as follows:

- the ray passes through  $v - e_1 - \cdots - e_k$ , for some  $v \in \text{vert}(Q_0)$ ; then

$$\begin{aligned}\langle \tilde{u}, v - e_1 - \cdots - e_k \rangle &= \langle u, v \rangle + \sum_{i=1}^k \min_{Q_i} u - \frac{k}{k+1} \min_Q u \\ &\geq \min_{Q_0} u + \min_{Q_1 + \cdots + Q_k} u - \frac{k}{k+1} \min_Q u \\ &= \min_Q u - \frac{k}{k+1} \min_Q u \\ &= \frac{1}{k+1} \min_Q u > 0;\end{aligned}$$

- the ray passes through  $v + e_i$ , for some  $v \in \text{vert}(Q_i)$  and  $1 \leq i \leq k$ ; then

$$\langle \tilde{u}, v + e_i \rangle = \langle u, v \rangle - \min_{Q_i} u + \frac{1}{k+1} \min_Q u \geq \frac{1}{k+1} \min_Q u > 0.$$

- the ray is a ray of  $\sigma$  through  $v \in N \setminus \{0\}$ ; then  $\langle \tilde{u}, v \rangle = \langle u, v \rangle > 0$ , because  $u \in \text{int}(\sigma^\vee)$ ;

This concludes the proof of the strong convexity of  $\tilde{\sigma}$ .

We now show that  $\tilde{\sigma}$  has dimension  $\text{rank } \tilde{N}$ . Equivalently we see that zero is the unique linear functional on  $\tilde{N}$  that vanishes over  $\tilde{\sigma}$ . Let  $\tilde{u} = u + \sum_{i=1}^k a_i e_i^* \in \tilde{M}$  be such that it vanishes over  $\tilde{\sigma}$ . In particular it vanishes over  $\sigma$ , hence  $u = 0$  because

$\sigma$  is full-dimensional. By evaluating  $\tilde{u}$  on  $Q_i + e_i$  we see that  $a_i$  must be zero. This implies that  $\tilde{u} = 0$ .

By Lemma 3.8 it is enough to show that the toric morphism  $\mathrm{TV}_{\mathbb{C}}(\sigma) \rightarrow \mathrm{TV}_{\mathbb{C}}(\tilde{\sigma})$  is a closed embedding.

Before proving this we shall prove the following claim:

$$\forall u \in \sigma^{\vee} \cap M, \quad \sum_{i=0}^k \left\lfloor \min_{Q_i} u \right\rfloor = \left\lfloor \min_Q u \right\rfloor. \quad (3.6)$$

Firstly we show that the minimum of  $u$  on  $Q$  is attained on a vertex of  $Q$ ; this comes from the strong convexity of  $\sigma$  as follows. By (i)  $\mathrm{rec}(Q)$  is contained in  $\sigma$  and so is a strongly convex cone. By [CLS11, 7.1.1b] we have

$$Q = \mathrm{conv} \langle \mathrm{vert}(Q) \rangle + \mathrm{rec}(Q). \quad (3.7)$$

Since  $u \in \sigma^{\vee}$ ,  $u$  is non-negative on  $\mathrm{rec}(Q)$ . Therefore there exists a vertex  $v$  of  $Q$  such that  $\min_Q u = \langle u, v \rangle$ . Now we prove the claim (3.6). By (iv) we may find vertices  $v_i \in \mathrm{vert}(Q_i)$ ,  $i = 0, 1, \dots, k$ , such that  $v = v_0 + v_1 + \dots + v_k$  and they are all integral with at most one exception. This implies that the numbers  $\langle u, v_0 \rangle, \langle u, v_1 \rangle, \dots, \langle u, v_k \rangle$  are all integral with at most one exception. Therefore

$$\sum_{i=0}^k \lfloor \langle u, v_i \rangle \rfloor = \lfloor \langle u, v \rangle \rfloor.$$

But  $\min_Q u = \langle u, v \rangle$  and it is clear that  $\min_{Q_i} u = \langle u, v_i \rangle$  for  $i = 0, 1, \dots, k$ . Therefore we have proved (3.6).

Now we prove that the toric morphism  $\mathrm{TV}_{\mathbb{C}}(\sigma) \rightarrow \mathrm{TV}_{\mathbb{C}}(\tilde{\sigma})$  is a closed embedding. Equivalently, we have to show that the semigroup homomorphism  $\phi: \tilde{\sigma}^{\vee} \cap \tilde{M} \rightarrow \sigma^{\vee} \cap M$  is surjective. Let  $u \in \sigma^{\vee} \cap M$  and consider

$$\tilde{u} = u - \sum_{i=1}^k \left\lfloor \min_{Q_i} u \right\rfloor e_i^* \in \tilde{M};$$

if we prove that  $\tilde{u} \in \tilde{\sigma}^{\vee}$  we have finished because the equality  $\phi(\tilde{u}) = u$  obviously holds true. It is clear that  $\tilde{u}$  is non-negative on  $\sigma$  and it is very easy to show that  $\tilde{u}$  is non-negative on  $Q_i + e_i$ , for each  $i = 1, \dots, k$ . So it remains to show that  $\tilde{u}$  is

non-negative on  $Q_0 - e_1 - \cdots - e_k$ . If  $q \in Q_0$ , then

$$\begin{aligned} \langle \tilde{u}, q - e_1 - \cdots - e_k \rangle &= \langle u, q \rangle + \sum_{i=1}^k \left\lfloor \min_{Q_i} u \right\rfloor \\ &\geq \left\lfloor \min_{Q_0} u \right\rfloor + \sum_{i=1}^k \left\lfloor \min_{Q_i} u \right\rfloor \\ &= \left\lfloor \min_Q u \right\rfloor \geq 0, \end{aligned}$$

where the last equality is (3.6) and the last inequality holds because of (i).

This concludes the proof of Theorem 3.4(A).  $\square$

**Lemma 3.9.** *Let  $(A, \mathfrak{m}, \kappa)$  be an artinian local ring and  $B$  be a flat  $A$ -algebra of finite type. Let  $b_1, \dots, b_k \in B$  generate the ideal  $J$  of  $B$ . If  $b_1, \dots, b_k$  is a  $(B \otimes_A \kappa)$ -regular sequence, then  $B/J$  is flat over  $A$ .*

*Proof.* Let  $P$  be a prime ideal of  $B$ . Since  $\mathfrak{m}$  is the unique prime ideal of  $A$ , we have  $\mathfrak{m} = P \cap A$  and  $A \rightarrow B_P$  is a local homomorphism. We need to show that  $(B/J)_P = B_P/JB_P$  is flat over  $A$ . If  $J \not\subseteq P$ , then  $(B/J)_P = 0$  and we are done. If  $J \subseteq P$ , then we conclude by [Mat89, Corollary to Theorem 22.5].  $\square$

*Proof of Theorem 3.4(B).* From (3.7) and the existence of the minimum of  $w$  on  $Q$ , we have that  $w$  is non-negative on  $\text{rec}(Q)$  and  $\min_Q w = \langle w, v \rangle$  for some vertex  $v$  of  $Q$ . By (iv) we may find vertices  $v_i \in \text{vert}(Q_i)$ ,  $i = 0, 1, \dots, k$ , such that  $v = v_0 + v_1 + \cdots + v_k$  and they are all integral with at most one exception. This implies that the numbers  $\langle w, v_0 \rangle, \langle w, v_1 \rangle, \dots, \langle w, v_k \rangle$  are all integral with at most one exception. Therefore

$$\sum_{i=0}^k \lfloor \langle w, v_i \rangle \rfloor = \lfloor \langle w, v \rangle \rfloor.$$

But  $\min_Q w = \langle w, v \rangle$  and it is clear that  $\min_{Q_i} w = \langle w, v_i \rangle$  for  $i = 0, 1, \dots, k$ . Therefore we have proved the equality

$$\sum_{i=0}^k \left\lfloor \min_{Q_i} w \right\rfloor = \left\lfloor \min_Q w \right\rfloor. \quad (3.8)$$

Now we show that the trinomials (3.1) are elements of

$$\mathbb{C}[t_1, \dots, t_k][x_\xi \mid \xi \in \tilde{\sigma}(1)],$$

which is the homogeneous coordinate ring of  $\text{TV}_{\mathbb{C}[t_1, \dots, t_k]}(\tilde{\sigma})$ . It is enough to show that



every Cox coordinate appearing in the third monomial in (3.1) has a non-negative exponent. Fix a ray  $\xi$  of  $\tilde{\sigma}$ . We may distinguish three cases as follows.

- $\xi$  passes through a vertex of  $Q_0 - e_1 - \cdots - e_k$ . Then  $\xi = \lambda(v_0 - e_1 - \cdots - e_k)$ , for some  $\lambda \in \mathbb{N}^+$  and  $v_0 \in \text{vert}(Q_0)$ . Then

$$\begin{aligned} \langle \tilde{w}, \xi \rangle &= \lambda \langle w, v_0 \rangle + \lambda \sum_{i=1}^k \left\lfloor \min_{Q_i} w \right\rfloor \\ &\geq \lambda \sum_{i=0}^k \left\lfloor \min_{Q_i} w \right\rfloor \\ &= \lambda \left\lfloor \min_Q w \right\rfloor \\ &\geq -\lambda, \end{aligned}$$

where the last equality holds by (3.8) and the last inequality holds by (v). Therefore the exponent of  $x_\xi$  in the third trinomial in (3.1), which is  $\langle \tilde{w}, \xi \rangle + \lambda$ , is non-negative.

- $\xi$  passes through a vertex of  $Q_i + e_i$ , for some  $1 \leq i \leq k$ . Then  $\xi = \lambda(v + e_i)$ , for some  $\lambda \in \mathbb{N}^+$  and  $v \in \text{vert}(Q_i)$ . Then  $\langle \tilde{w}, \xi \rangle = \lambda \langle w, v \rangle - \lambda \lfloor \min_{Q_i} w \rfloor \geq 0$ .
- $\xi$  is a ray of  $\sigma$  too. We need to show that  $\langle \tilde{w}, \xi \rangle = \langle w, \xi \rangle$  is non-negative. For a contradiction assume that  $\langle w, \xi \rangle < 0$ . Therefore a positive multiple of  $\xi$  lies in the polyhedron  $P := \sigma \cap \{n \in N_{\mathbb{R}} \mid \langle w, n \rangle = -1\}$ . Since  $\text{rec}(P)$  is strongly convex,  $P = \text{conv}(\text{vert}(P)) + \text{rec}(P)$  by [CLS11, Proposition 7.1.1.b]. By (vi) we obtain that  $\xi = \lambda q + r$ , for some  $\lambda > 0$ ,  $q \in Q$ ,  $r \in \text{rec}(P)$ . Since  $\lambda q$  and  $r$  are both in  $\sigma$  and  $\xi$  is a ray of  $\sigma$ , we have that either  $\lambda q = 0$  or  $r = 0$ . By (ii) we have  $r = 0$ , so  $\xi = \lambda q$ . From (iii) we have that  $\xi$  is in cone  $\langle Q_0 - e_1 - \cdots - e_k, Q_1 + e_1, \dots, Q_k + e_k \rangle$ . This contradicts the fact that  $\xi$  is a ray of both  $\sigma$  and  $\tilde{\sigma}$ .

Let  $\mathcal{X}$  be the closed subscheme of  $\text{TV}_{\mathbb{C}}(\tilde{\sigma}) \times_{\text{Spec } \mathbb{C}} \mathbb{A}_{\mathbb{C}}^k = \text{TV}_{\mathbb{C}[t_1, \dots, t_k]}(\tilde{\sigma})$  defined by the homogeneous ideal generated by the trinomials in (3.1), which we have proved to be well defined. The composite  $\mathcal{X} \hookrightarrow \text{TV}_{\mathbb{C}}(\tilde{\sigma}) \times_{\text{Spec } \mathbb{C}} \mathbb{A}_{\mathbb{C}}^k \rightarrow \mathbb{A}_{\mathbb{C}}^k$  is a scheme morphism whose fibre over  $O \in \mathbb{A}_{\mathbb{C}}^k$  is  $\text{TV}_{\mathbb{C}}(\sigma)$ . We need to show that its restriction to any infinitesimal neighbourhood of  $O \in \mathbb{A}_{\mathbb{C}}^k$  is flat.

Fix a  $(t_1, \dots, t_k)$ -primary ideal  $\mathfrak{q}$ . Consider the local artinian  $\mathbb{C}$ -algebra  $A = \mathbb{C}[t_1, \dots, t_k]/\mathfrak{q}$ . We need to show that  $\mathcal{X} \times_{\mathbb{A}_{\mathbb{C}}^k} \text{Spec } A \rightarrow \text{Spec } A$  is flat. The homogeneous coordinate ring of  $\text{TV}_A(\tilde{\sigma})$  is the polynomial  $A$ -algebra  $B = A[x_\xi \mid \xi \in \tilde{\sigma}(1)]$ . By (A) the trinomials (3.1) form a  $(B \otimes_A \mathbb{C})$ -regular sequence. By Lemma 3.9 the

homogeneous ideal  $J \subseteq B$  generated by the trinomials (3.1) is such that  $B/J$  is flat over  $A$ . By Lemma 3.2 the sheafification of the  $G_{\tilde{\sigma}}$ -graded  $B$ -module  $B/J$  is a coherent sheaf on  $\mathrm{TV}_A(\tilde{\sigma})$  which is flat over  $\mathrm{Spec} A$ . This sheaf is the structure sheaf of the closed subscheme  $\mathcal{X} \times_{\mathbb{A}_{\mathbb{C}}^k} \mathrm{Spec} A$  of  $\mathrm{TV}_A(\tilde{\sigma})$ . Therefore we have proved that  $\mathcal{X} \times_{\mathbb{A}_{\mathbb{C}}^k} \mathrm{Spec} A$  is flat over  $\mathrm{Spec} A$ .

This concludes the proof of Theorem 3.4(B).  $\square$

### 3.3. Deformations of toric affine pairs

Under additional hypotheses with respect to Theorem 3.4, Mavlyutov's construction of deformations of toric affine varieties, which appears in [Mav] and is rewritten in §3.2, actually gives deformations of their toric boundary too. Therefore, roughly speaking, Minkowski decompositions give deformations of the pair  $(X, \partial X)$ , where  $X$  is an affine toric variety and  $\partial X$  is its toric boundary.

In the setting of Theorem 3.4 the additional hypothesis is that the polyhedra  $Q_1, \dots, Q_k$  must have lattice vertices (see (iv') in Theorem 3.10). If this is the case, from a Minkowski decomposition  $Q_0 + Q_1 + \dots + Q_k$  of a polyhedron  $Q$  in a cone  $\sigma$ , we construct a bigger cone  $\tilde{\sigma}$  and a reduced divisor  $\mathcal{D}$  in the toric variety  $\mathrm{TV}_{\mathbb{C}}(\tilde{\sigma})$  such that  $\mathrm{TV}_{\mathbb{C}}(\sigma)$  is a closed subscheme of  $\mathrm{TV}_{\mathbb{C}}(\tilde{\sigma})$  defined by binomial equations and  $\mathcal{D} \cap \mathrm{TV}_{\mathbb{C}}(\sigma)$  is the toric boundary  $\partial \mathrm{TV}_{\mathbb{C}}(\sigma)$  of  $\mathrm{TV}_{\mathbb{C}}(\sigma)$ . Theorem 3.4 constructs a formal deformation  $\mathcal{X} \rightarrow \mathbb{A}_{\mathbb{C}}^k$  of  $\mathrm{TV}_{\mathbb{C}}(\sigma)$  as a closed subscheme in the trivial family  $\mathrm{TV}_{\mathbb{C}}(\tilde{\sigma}) \times_{\mathbb{C}} \mathbb{A}_{\mathbb{C}}^k$ ; then one can see that the subscheme  $\mathcal{X} \cap (\mathcal{D} \times_{\mathbb{C}} \mathbb{A}_{\mathbb{C}}^k)$  gives a deformation of the toric boundary  $\partial \mathrm{TV}_{\mathbb{C}}(\sigma)$ . In other words,  $(\mathcal{X}, \mathcal{X} \cap (\mathcal{D} \times_{\mathbb{C}} \mathbb{A}_{\mathbb{C}}^k)) \rightarrow \mathbb{A}_{\mathbb{C}}^k$  induces a formal deformation of the toric pair  $(\mathrm{TV}_{\mathbb{C}}(\sigma), \partial \mathrm{TV}_{\mathbb{C}}(\sigma))$ . The precise statement is the following.

**Theorem 3.10.** *Let  $N$  be a lattice and let  $\sigma \subseteq N_{\mathbb{R}}$  be a strongly convex rational polyhedral cone of dimension  $\mathrm{rank} N$ . Consider the affine toric variety  $\mathrm{TV}_{\mathbb{C}}(\sigma)$  with its toric boundary  $\partial \mathrm{TV}_{\mathbb{C}}(\sigma)$ . Let  $Q, Q_0, Q_1, \dots, Q_k$  be non-empty rational polyhedra in  $N_{\mathbb{R}}$  such that:*

$$(i) \quad Q \subseteq \sigma;$$

$$(ii) \quad 0 \notin Q;$$

$$(iii) \quad Q = Q_0 + Q_1 + \dots + Q_k;$$

$$(iv') \quad Q_1, \dots, Q_k \text{ are lattice polyhedra.}$$

Consider the lattice  $\tilde{N} = N \oplus \mathbb{Z}e_1 \oplus \cdots \oplus \mathbb{Z}e_k$  and the cone

$$\tilde{\sigma} = \text{cone} \langle \sigma, Q_0 - e_1 - \cdots - e_k, Q_1 + e_1, \dots, Q_k + e_k \rangle \subseteq \tilde{N}_{\mathbb{R}}.$$

(A) Then  $\tilde{\sigma}$  is a strongly convex rational polyhedral cone in  $\tilde{N}$  and the toric morphism  $\text{TV}_{\mathbb{C}}(\sigma) \rightarrow \text{TV}_{\mathbb{C}}(\tilde{\sigma})$ , induced by the inclusion  $N \hookrightarrow \tilde{N}$ , is a closed embedding and identifies  $\text{TV}_{\mathbb{C}}(\sigma)$  with the closed subscheme of  $\text{TV}_{\mathbb{C}}(\tilde{\sigma})$  associated to the homogeneous ideal generated by the following binomials in the Cox coordinates of  $\text{TV}_{\mathbb{C}}(\tilde{\sigma})$ :

$$\prod_{\substack{\xi \in \tilde{\sigma}(1): \\ \langle e_i^*, \xi \rangle > 0}} x_{\xi}^{\langle e_i^*, \xi \rangle} - \prod_{\substack{\xi \in \tilde{\sigma}(1): \\ \langle e_i^*, \xi \rangle < 0}} x_{\xi}^{-\langle e_i^*, \xi \rangle} \quad (3.9)$$

for  $i = 1, \dots, k$ . Now consider the reduced effective divisor  $\mathcal{D}$  on  $\text{TV}_{\mathbb{C}}(\tilde{\sigma})$  defined by the homogeneous ideal generated by the following monomial in the Cox coordinates of  $\text{TV}_{\mathbb{C}}(\tilde{\sigma})$ :

$$\prod_{\substack{\xi \in \tilde{\sigma}(1): \\ \forall i \in \{1, \dots, k\}, \langle e_i^*, \xi \rangle \leq 0}} x_{\xi}. \quad (3.10)$$

Then the scheme-theoretic intersection  $\text{TV}_{\mathbb{C}}(\sigma) \cap \mathcal{D}$  coincides with the toric boundary  $\partial \text{TV}_{\mathbb{C}}(\sigma)$  of  $\text{TV}_{\mathbb{C}}(\sigma)$ . Moreover the  $k$  binomials in (3.9) and the monomial in (3.10) form a regular sequence of length  $k + 1$ .

(B) In addition, assume that  $w \in M$  is such that the following two conditions hold:

(v) the minimum of  $w$  on  $Q$  exists and is not smaller than  $-1$ ;

(vi) every vertex of the polyhedron  $\sigma \cap \{n \in N_{\mathbb{R}} \mid \langle w, n \rangle = -1\}$  is contained in  $\mathbb{R}^+ \cdot Q$ .

Consider

$$\tilde{w} = w - \sum_{i=1}^k \left( \min_{Q_i} w \right) e_i^* \in \tilde{M}.$$

Let  $t_1, \dots, t_k$  be the standard coordinates on  $\mathbb{A}_{\mathbb{C}}^k$ . Consider the closed subscheme  $\mathcal{X}$  of  $\text{TV}_{\mathbb{C}}(\tilde{\sigma}) \times_{\text{Spec } \mathbb{C}} \mathbb{A}_{\mathbb{C}}^k = \text{TV}_{\mathbb{C}[t_1, \dots, t_k]}(\tilde{\sigma})$  defined by the homogeneous ideal generated by the following trinomials in Cox coordinates:

$$\prod_{\substack{\xi \in \tilde{\sigma}(1): \\ \langle e_i^*, \xi \rangle > 0}} x_{\xi}^{\langle e_i^*, \xi \rangle} - \prod_{\substack{\xi \in \tilde{\sigma}(1): \\ \langle e_i^*, \xi \rangle < 0}} x_{\xi}^{-\langle e_i^*, \xi \rangle} - t_i \prod_{\xi \in \tilde{\sigma}(1)} x_{\xi}^{\langle \tilde{w}, \xi \rangle} \prod_{\substack{\xi \in \tilde{\sigma}(1): \\ \langle e_i^*, \xi \rangle < 0}} x_{\xi}^{-\langle e_i^*, \xi \rangle} \quad (3.11)$$

for  $i = 1, \dots, k$ . Then the closed embedding  $\mathcal{X} \cap (\mathcal{D} \times_{\text{Spec } \mathbb{C}} \mathbb{A}_{\mathbb{C}}^k) \hookrightarrow \mathcal{X}$  induces a formal deformation of the toric pair  $(\text{TV}_{\mathbb{C}}(\sigma), \partial \text{TV}_{\mathbb{C}}(\sigma))$  over  $\mathbb{C}[[t_1, \dots, t_k]]$ .

The meaning of “formal deformation” is explained in Remark 3.5.

*Proof of Theorem 3.10.* Since almost everything has been proved in the work of Mavlyutov [Mav] (see Theorem 3.4), it is enough to deal with the toric boundary. Here we adopt some notations used in the proof of Lemma 3.8. Let  $I$  be the kernel of the surjective ring homomorphism  $\psi: \mathbb{C}[\tilde{\sigma}^\vee \cap \tilde{M}] \rightarrow \mathbb{C}[\sigma^\vee \cap M]$  that is associated to the surjective semigroup homomorphism  $\phi: \tilde{\sigma}^\vee \cap \tilde{M} \rightarrow \sigma^\vee \cap M$  given by  $u + a_1 e_1^* + \cdots + a_k e_k^* \mapsto u$ . The ideal of the toric boundary  $\partial \text{TV}_{\mathbb{C}}(\sigma)$  in  $\text{TV}_{\mathbb{C}}(\sigma)$  is

$$\bigoplus_{u \in \text{int}(\sigma^\vee) \cap M} \mathbb{C}\chi^u.$$

Therefore the ideal of  $\partial \text{TV}_{\mathbb{C}}(\sigma)$  in  $\text{TV}_{\mathbb{C}}(\tilde{\sigma})$  is

$$\begin{aligned} \bar{I} &:= \psi^{-1} \left( \bigoplus_{u \in \text{int}(\sigma^\vee) \cap M} \mathbb{C}\chi^u \right) \\ &= I + \sum_{u + a_1 e_1^* + \cdots + a_k e_k^* \in ((\text{int}(\sigma^\vee) \cap M) \times \mathbb{Z}^k) \cap \tilde{\sigma}^\vee} \mathbb{C}\chi^{u + a_1 e_1^* + \cdots + a_k e_k^*}. \end{aligned}$$

Now we consider the Cox ring of  $\text{TV}_{\mathbb{C}}(\tilde{\sigma})$ :  $S = \mathbb{C}[x_\xi \mid \xi \in \tilde{\sigma}(1)]$  with its  $G_{\tilde{\sigma}}$ -grading. In the proof of Theorem 3.4(A) we had the following description of the rays of  $\tilde{\sigma}$ .

- Rays passing through the vertices of  $Q_0 - e_1 - \cdots - e_k$ . We denote by  $z_{0,1}, \dots, z_{0,s_0}$  the corresponding Cox coordinates.
- Rays passing through the vertices of  $Q_i + e_i$ , as  $i = 1, \dots, k$ . We denote by  $y_{i,1}, \dots, y_{i,s_i}$  the corresponding Cox coordinates.
- Rays of  $\sigma$  that are not in the cone generated by the previous rays. We denote by  $z_{\sigma,1}, \dots, z_{\sigma,s_\sigma}$  the corresponding Cox coordinates.

Consider the following monomials in Cox coordinates:

$$\begin{aligned} y_i &= \prod_{\substack{\xi \in \tilde{\sigma}(1): \\ \langle e_i^*, \xi \rangle > 0}} x_\xi^{\langle e_i^*, \xi \rangle} = y_{i,1} \cdots y_{i,s_i} && \text{for each } i \in \{1, \dots, k\}, \\ z_0 &= \prod_{\substack{\xi \in \tilde{\sigma}(1): \\ \langle e_i^*, \xi \rangle < 0}} x_\xi^{-\langle e_i^*, \xi \rangle} = z_{0,1}^{a_0} \cdots z_{0,s_0}^{a_{s_0}} && \text{for any } i \in \{1, \dots, k\}, \\ z_0^{\text{red}} &= \prod_{\substack{\xi \in \tilde{\sigma}(1): \\ \langle e_i^*, \xi \rangle < 0}} x_\xi = z_{0,1} \cdots z_{0,s_0} && \text{for any } i \in \{1, \dots, k\}, \end{aligned}$$

$$\begin{aligned}
z_\sigma &= \prod_{\substack{\xi \in \tilde{\sigma}(1): \\ \langle e_i^*, \xi \rangle = 0}} x_\xi = z_{\sigma,1} \cdots z_{\sigma,s_\sigma} && \text{for any } i \in \{1, \dots, k\}, \\
z &= \prod_{\substack{\xi \in \tilde{\sigma}(1): \\ \langle e_i^*, \xi \rangle \leq 0}} x_\xi = z_0^{\text{red}} z_\sigma && \text{for any } i \in \{1, \dots, k\}.
\end{aligned}$$

Here we have used (iv') to deduce that  $y_i$  are reduced monomials. The exponents  $a_0, \dots, a_{s_0}$  are the minimal positive integers by which we have to multiply the vertices of  $Q_0$  to get lattice points. We see that  $y_i$  are exactly the ones used in the proof of Lemma 3.8, whereas the monomials  $z_1, \dots, z_k$  there coincides with  $z_0$  in our case. We see that  $y_i - z_0$  is the binomial in (3.9) and  $z$  is the monomial in (3.10). Let  $J \subseteq S$  be the ideal generated by  $y_1 - z_0, \dots, y_k - z_0$  and let  $\bar{J} = J + Sz$ . We already know, from Lemma 3.8 or Theorem 3.4, that the Cox isomorphism between  $\mathbb{C}[\tilde{\sigma}^\vee \cap M]$  and  $S_0 \subseteq S$  maps the ideal  $I$  onto the degree zero part of the ideal  $J$ , i.e.  $\text{Cox}(I) = J \cap S_0$ . We have to prove that

$$\text{Cox}(\bar{I}) = \bar{J} \cap S_0. \quad (3.12)$$

This equality will imply that the scheme-theoretic intersection  $\text{TV}_{\mathbb{C}}(\sigma) \cap \mathcal{D}$  coincides with  $\partial \text{TV}_{\mathbb{C}}(\sigma)$ .

We now prove the containment  $\subseteq$  in (3.12). Since  $\text{Cox}(I) \subseteq J \subseteq \bar{J}$ , it is enough to show that  $\text{Cox}(\chi^{\tilde{u}}) = x^{\tilde{u}} \in \bar{J}$  whenever  $\tilde{u} = u + a_1 e_1^* + \cdots + a_k e_k^* \in \tilde{\sigma}^\vee \cap \tilde{M}$  is such that  $u \in \text{int}(\sigma^\vee)$ . We have that  $z_\sigma$  divides  $x^{\tilde{u}}$  because  $u$  is in the strict interior of  $\sigma^\vee$ . Since  $\tilde{u} \in \tilde{\sigma}^\vee$ ,  $\tilde{u}$  cannot take negative values on  $Q_0 - e_1 - \cdots - e_k, Q_1 + e_1, \dots, Q_k + e_k$ . If  $\tilde{u}$  is strictly positive on  $Q_0 - e_1 - \cdots - e_k$ , then  $z_0^{\text{red}}$  divides  $x^{\tilde{u}}$ , and hence  $z = z_0^{\text{red}} z_\sigma$  divides  $x^{\tilde{u}}$ , which implies that  $x^{\tilde{u}}$  lies in  $\bar{J}$  and we are done. So we may assume that  $0 = \min_{Q_0 - e_1 - \cdots - e_k} \tilde{u} = \min_{Q_0} u - a_1 - \cdots - a_k$ . Therefore, since  $u \in \text{int}(\sigma^\vee)$  and  $0 \notin Q$ , we have

$$\begin{aligned}
0 &< \min_Q u \\
&= \min_{Q_0} u + \min_{Q_1} u + \cdots + \min_{Q_k} u \\
&= \sum_{i=1}^k \left( a_i + \min_{Q_i} u \right) \\
&= \sum_{i=1}^k \min_{Q_i + e_i} \tilde{u}.
\end{aligned}$$

So, there exists  $i \in \{1, \dots, k\}$  such that  $\min_{Q_i + e_i} \tilde{u} > 0$ . This implies that  $y_i$  divides

$x^{\tilde{u}}$ , i.e. there exists a monomial  $p$  such that  $x^{\tilde{u}} = py_i$ . Since  $z_\sigma | x^{\tilde{u}}$ , we know that  $z_\sigma | p$ . By writing  $x^{\tilde{u}} = p(y_i - z_0) + pz_0$  and by noting that  $z$  divides  $pz_0$ , we conclude that  $x^{\tilde{u}}$  lies in  $\bar{J}$ .

We now prove the containment  $\supseteq$  in (3.12). By using the same argument as in the second part of the proof of Lemma 3.8, it is enough to show that if  $\tilde{u} = u + a_1 e_1^* + \cdots + a_k e_k^* \in \tilde{\sigma}^\vee \cap \tilde{M}$  is such that  $x^{\tilde{u}} = pz$  for some monomial  $p \in S$  then  $u \in \text{int}(\sigma^\vee)$ . Since  $z$  divides  $x^{\tilde{u}}$ , we see that  $\tilde{u}$  is strictly positive on  $Q_0 - e_1 - \cdots - e_k$  and on the rays of  $\sigma$  that are not in the cone generated by  $Q_0 - e_1 - \cdots - e_k, Q_1 + e_1, \dots, Q_k + e_k$ . Now we want to prove that  $u$  is strictly positive on the non-zero elements of  $\sigma$ ; if  $v \in \sigma$  we can write  $v = \lambda(q_0 - e_1 - \cdots - e_k) + \lambda(q_1 + e_1) + \cdots + \lambda(q_k + e_k) + v_\sigma = \lambda(q_0 + q_1 + \cdots + q_k) + v_\sigma$ , for some  $\lambda \geq 0$ ,  $q_i \in Q_i$ , and  $v_\sigma$  in the cone generated by the rays of  $\sigma$  that are not in the cone generated by  $Q_0 - e_1 - \cdots - e_k, Q_1 + e_1, \dots, Q_k + e_k$ . We have

$$\langle u, v \rangle = \lambda [\langle \tilde{u}, q_0 - e_1 - \cdots - e_k \rangle + \langle \tilde{u}, q_1 + e_1 \rangle + \cdots + \langle \tilde{u}, q_k + e_k \rangle] + \langle \tilde{u}, v_\sigma \rangle.$$

Since  $v \neq 0$ , we have that either  $\lambda > 0$  or  $v_\sigma \neq 0$ ; this implies  $\langle u, v \rangle > 0$ .

Now we prove that  $y_1 - z_0, \dots, y_k - z_0, z$  is a regular sequence. From Theorem 3.4(A) we know that the first  $k$  elements form a regular sequence. In order to show that all the  $k + 1$  elements form a regular sequence we have to show the equality  $(J : z) = J$ , where  $J$  is the ideal generated by  $y_1 - z_0, \dots, y_k - z_0$ .

It is clear that  $y_1, \dots, y_k, z_0^{\text{red}}$  is a regular sequence in  $S$ . Therefore the ideal  $(y_1, \dots, y_k, z_0^{\text{red}}) = (y_1 - z_0, \dots, y_k - z_0, z_0^{\text{red}})$  has height  $k + 1$ . Since the polynomial ring  $S$  is Cohen–Macaulay we have that  $y_1 - z_0, \dots, y_k - z_0, z_0^{\text{red}}$  is a regular sequence. In particular  $(J : z_0^{\text{red}}) = J$ . From the fact that  $z_\sigma$  does not involve any variable that appears in the generators of  $J$  we have  $(J : z_\sigma) = J$ . We conclude with the following chain of equalities:  $(J : z) = ((J : z_0^{\text{red}}) : z_\sigma) = (J : z_\sigma) = J$ .

This concludes the proof of part (A) of Theorem 3.10. For part (B) we may adapt the same proof of Theorem 3.4.  $\square$

### 3.4. Deformations of projective toric varieties

In this section we study deformations of polarised projective toric varieties. Our strategy is to deform the corresponding affine cones thanks to Mavlyutov’s theorem (Theorem 3.4) and then apply the Proj functor.

We begin with a well known characterisation of polarised projective toric varieties.

**Lemma 3.11** (Polarised projective toric varieties). *If  $N$  is a lattice of rank  $n$ , then the following data are naturally equivalent:*

1. a pair  $(X, D)$ , where  $X$  is a projective normal toric variety over  $\mathbb{C}$  with respect to the torus  $T_N = \text{Spec } \mathbb{C}[M]$  and  $D$  is an ample torus-invariant  $\mathbb{Q}$ -Cartier  $\mathbb{Q}$ -divisor on  $X$ ;
2. a pair  $(\Sigma, \varphi)$ , where  $\Sigma$  is a complete fan in  $N$  and  $\varphi$  is a strictly convex rational support function on  $\Sigma$ , i.e.  $\varphi: N_{\mathbb{R}} \rightarrow \mathbb{R}$  is a continuous function such that
  - for every  $\sigma \in \Sigma(n)$ , there exists  $u_{\sigma} \in M_{\mathbb{Q}}$  such that  $\varphi(v) = \langle u_{\sigma}, v \rangle$  for all  $v \in \sigma$ ;
  - for every  $\sigma \in \Sigma(n)$ ,  $\varphi(v) < \langle u_{\sigma}, v \rangle$  for all  $v \in N_{\mathbb{R}} \setminus \sigma$ ;
3. a rational polytope  $P \subseteq M_{\mathbb{R}}$  of dimension  $n$ .
4. a strictly convex rational polyhedral cone  $\tau$  in the lattice  $N_0 = N \oplus \mathbb{Z}e_0$  such that the dimension of  $\tau$  is  $n + 1$  and  $e_0$  is in the interior of  $\tau$ ;

In the setting above there are natural bijective correspondences if in addition we require the following further conditions too:

1.  $D$  is a Cartier divisor on  $X$ ;
2.  $\varphi$  is a strictly convex integral support function on  $\Sigma$ , i.e. we also require that  $u_{\sigma} \in M$  for every  $\sigma \in \Sigma(n)$ ;
3.  $P$  is a lattice polytope;
4. every facet of  $\tau$  is contained in a hyperplane of the form  $(u + e_0)^{\perp}$  for some  $u \in M$ .

*Sketch of proof of Lemma 3.11.* The equivalence among (1), (2), and (3) is well known (at least under the additional conditions) and associates the pair  $(\Sigma, \varphi)$  to the pair  $(\text{TV}_{\mathbb{C}}(\Sigma), D)$ , where  $D = -\sum_{\rho \in \Sigma(1)} \varphi(\rho)D_{\rho}$ , and to the polytope

$$P = \bigcap_{\rho \in \Sigma(1)} \{u \in M_{\mathbb{R}} \mid \langle u, \rho \rangle \geq \varphi(\rho)\}.$$

Conversely,  $\Sigma$  is the normal fan of  $P$  and  $\varphi = \min_{u \in P} \langle u, \cdot \rangle$ . We refer the reader to [CLS11, §6] for more details.

The equivalence with (4) is as follows:  $\tau$  is the convex hull of the graph of the function  $-\varphi$ , i.e.  $\tau = \{v + ke_0 \in N_{\mathbb{R}} \oplus \mathbb{R}e_0 \mid \varphi(v) + k \geq 0\}$ , or equivalently the

cone with rays  $\rho - \varphi(\rho)e_0$  as  $\rho \in \Sigma(1)$ . Conversely, the cones of  $\Sigma$  are precisely the images of the faces of  $\tau$  along the projection  $N \oplus \mathbb{Z}e_0 \rightarrow N$  and  $P = \tau^\vee \cap e_0^{-1}(1)$ .  $\square$

**Theorem 3.12.** *Let  $N$  be a lattice of rank  $n$  and let  $\tau$  be a  $(n+1)$ -dimensional strongly convex rational polyhedral cone in the lattice  $N_0 = N \oplus \mathbb{Z}e_0$  such that  $e_0 \in \text{int}(\tau)$ . Let  $Q, Q_0, Q_1, \dots, Q_k$  be non-empty rational polyhedra in  $(N_0)_\mathbb{R}$  such that:*

(i)  $Q \subseteq \tau$ ;

(ii)  $0 \notin Q$ ;

(iii)  $Q = Q_0 + Q_1 + \dots + Q_k$ ;

(iv) for every vertex  $v \in \text{vert}(Q)$ , there exist vertices  $v_0 \in \text{vert}(Q_0)$ ,  $v_1 \in \text{vert}(Q_1)$ ,  $\dots$ ,  $v_k \in \text{vert}(Q_k)$  such that  $v = v_0 + v_1 + \dots + v_k$  and

$$\#\{i \in \{0, 1, \dots, k\} \mid v_i \notin N\} \leq 1.$$

Consider the lattice  $\tilde{N}_0 = N \oplus \mathbb{Z}e_0 \oplus \mathbb{Z}e_1 \oplus \dots \oplus \mathbb{Z}e_k$  and the cone

$$\tilde{\tau} = \text{cone} \langle \tau, Q_0 - e_1 - \dots - e_k, Q_1 + e_1, \dots, Q_k + e_k \rangle \subseteq (\tilde{N}_0)_\mathbb{R}.$$

(A) Then  $\tilde{\tau}$  is a  $(n+1+k)$ -dimensional strongly convex rational polyhedral cone in  $\tilde{N}_0$  such that  $e_0 \in \text{int}(\tilde{\tau})$ . If  $(X, D)$  and  $(\tilde{X}, \tilde{D})$  are the pairs associated to  $\tau$  and  $\tilde{\tau}$  via Lemma 3.11, then the inclusion  $\tau \hookrightarrow \tilde{\tau}$  induces a toric closed embedding  $\iota: X \hookrightarrow \tilde{X}$  which identifies  $X$  with the closed subscheme of  $\tilde{X}$  associated to the homogeneous ideal generated by the following binomials in the Cox coordinates of  $\tilde{X}$ :

$$\prod_{\substack{\rho \in \tilde{\Sigma}(1): \\ \langle e_i^*, \rho \rangle > 0}} x_\rho^{\langle e_i^*, \rho \rangle} - \prod_{\substack{\rho \in \tilde{\Sigma}(1): \\ \langle e_i^*, \rho \rangle < 0}} x_\rho^{-\langle e_i^*, \rho \rangle} \quad (3.13)$$

for  $i = 1, \dots, k$ , where  $\tilde{\Sigma}$  is the fan in  $\tilde{N} = N \oplus \mathbb{Z}e_1 \oplus \dots \oplus \mathbb{Z}e_k$  of  $\tilde{X}$ . Moreover, these binomials form a regular sequence of length  $k$ .

(B) In addition, assume that  $w \in M$  is such that the following two conditions hold:

(v) the minimum of  $w$  on  $Q$  exists and is not smaller than  $-1$ ;

(vi) every vertex of the polyhedron  $\tau \cap \{v + ke_0 \in (N_0)_\mathbb{R} \mid k \in \mathbb{R}, \langle w, v \rangle = -1\}$  is contained in  $\mathbb{R}^+ \cdot Q$ .



Consider

$$\tilde{w} = w - \sum_{i=1}^k \left[ \min_{Q_i} w \right] e_i^* \in \tilde{M} \subseteq \tilde{M}_0.$$

Let  $t_1, \dots, t_k$  be the standard coordinates on  $\mathbb{A}_{\mathbb{C}}^k$ . Consider the closed subscheme of  $\tilde{X} \times_{\text{Spec } \mathbb{C}} \mathbb{A}_{\mathbb{C}}^k = \text{TV}_{\mathbb{C}[t_1, \dots, t_k]}(\tilde{\Sigma})$  defined by the homogeneous ideal generated by the following trinomials in Cox coordinates:

$$\prod_{\substack{\rho \in \tilde{\Sigma}(1): \\ \langle e_i^*, \rho \rangle > 0}} x_{\rho}^{\langle e_i^*, \rho \rangle} - \prod_{\substack{\rho \in \tilde{\Sigma}(1): \\ \langle e_i^*, \rho \rangle < 0}} x_{\rho}^{-\langle e_i^*, \rho \rangle} - t_i \prod_{\rho \in \tilde{\Sigma}(1)} x_{\rho}^{\langle \tilde{w}, \rho \rangle} \prod_{\substack{\rho \in \tilde{\Sigma}(1): \\ \langle e_i^*, \rho \rangle < 0}} x_{\rho}^{-\langle e_i^*, \rho \rangle} \quad (3.14)$$

for  $i = 1, \dots, k$ . This closed subscheme induces a deformation of  $X$  over  $\mathbb{C}[[t_1, \dots, t_k]]$  and over an open neighbourhood of the origin in  $\mathbb{A}_{\mathbb{C}}^k$ .

In the following remark we spell out a very simple situation where we may apply Theorem 3.12. This will be useful in the case of mutations of Fano polytopes.

**Remark 3.13** (The case of two Minkowski summands). Let  $N$  be a lattice of rank  $n$  and let  $\tau$  be a  $(n+1)$ -dimensional strongly convex rational polyhedral cone in the lattice  $N_0 = N \oplus \mathbb{Z}e_0$  such that  $e_0 \in \text{int}(\tau)$ . Let  $w \in M$  and let  $G$  and  $F$  be non-empty rational polyhedra in  $(N_0)_{\mathbb{R}}$  that satisfy the following conditions:

- (i)  $G + F \subseteq \tau$ ;
- (ii)  $G \subseteq \{v + ke_0 \in (N_0)_{\mathbb{R}} \mid k \in \mathbb{R}, \langle w, v \rangle = -1\}$ ;
- (iii)  $F \subseteq w^{\perp}$ ;
- (iv)  $F$  is a lattice polyhedron;
- (v) every vertex of the polyhedron  $\tau \cap \{v + ke_0 \in (N_0)_{\mathbb{R}} \mid k \in \mathbb{R}, \langle w, v \rangle = -1\}$  is contained in  $G + F$ .

Consider the lattice  $\tilde{N}_0 = N \oplus \mathbb{Z}e_0 \oplus \mathbb{Z}e_1$  and the cone  $\tilde{\tau} = \text{cone} \langle \tau, G - e_1, F + e_1 \rangle \subseteq (\tilde{N}_0)_{\mathbb{R}}$ .

Then  $\tilde{\tau}$  is a  $(n+2)$ -dimensional strongly convex rational polyhedral cone in  $\tilde{N}_0$  such that  $e_0 \in \text{int}(\tilde{\tau})$ . If  $(X, D)$  and  $(\tilde{X}, \tilde{D})$  are the pairs associated to  $\tau$  and  $\tilde{\tau}$  via Lemma 3.11, then the inclusion  $\tau \hookrightarrow \tilde{\tau}$  induces a toric closed embedding  $\iota: X \hookrightarrow \tilde{X}$  which identifies  $X$  with the closed subscheme of  $\tilde{X}$  associated to the homogeneous ideal generated by the following binomial in the Cox coordinates of  $\tilde{X}$ :

$$\prod_{\substack{\rho \in \tilde{\Sigma}(1): \\ \langle e_1^*, \rho \rangle > 0}} x_{\rho}^{\langle e_1^*, \rho \rangle} - \prod_{\substack{\rho \in \tilde{\Sigma}(1): \\ \langle e_1^*, \rho \rangle < 0}} x_{\rho}^{-\langle e_1^*, \rho \rangle},$$

where  $\tilde{\Sigma}$  is the fan in  $\tilde{N} = N \oplus \mathbb{Z}e_1$  of  $\tilde{X}$ .

Moreover, if we vary the coefficients of the trinomial

$$\prod_{\substack{\rho \in \tilde{\Sigma}(1): \\ \langle e_1^*, \rho \rangle > 0}} x_\rho^{\langle e_1^*, \rho \rangle} + \prod_{\substack{\rho \in \tilde{\Sigma}(1): \\ \langle e_1^*, \rho \rangle < 0}} x_\rho^{-\langle e_1^*, \rho \rangle} + \prod_{\rho \in \tilde{\Sigma}(1)} x_\rho^{\langle w, \rho \rangle} \prod_{\substack{\rho \in \tilde{\Sigma}(1): \\ \langle e_1^*, \rho \rangle < 0}} x_\rho^{-\langle e_1^*, \rho \rangle}$$

we get a flat family of closed subschemes of  $\tilde{X}$  over  $\mathbb{P}_{\mathbb{C}}^2$ , thanks to Proposition 3.3, such that the fibre over  $[1 : -1 : 0]$  is  $X$ .

The rest of this section is devoted to the proof of Theorem 3.12. We begin with a description of a polarised toric variety as the Proj of an  $\mathbb{N}$ -graded ring constructed from the cone  $\tau$  as in Lemma 3.11.

**Remark 3.14.** Let  $N$  be a lattice of rank  $n$ , let  $\tau$  be a  $(n+1)$ -dimensional strongly convex rational polyhedral cone in the lattice  $N_0 = N \oplus \mathbb{Z}e_0$  such that  $e_0 \in \text{int}(\tau)$ , and let  $(X, D)$  and  $(\Sigma, \varphi)$  be the pairs associated to  $\tau$  via Lemma 3.11. Then  $X = \text{Proj } \mathbb{C}[\tau^\vee \cap M_0]$  where the ring  $\mathbb{C}[\tau^\vee \cap M_0]$  has the  $\mathbb{N}$ -grading given by  $e_0$ , i.e. the degree of  $\chi^{u+he_0^*}$  is  $h$  for every  $u \in M$  such that  $u + he_0^* \in \tau^\vee \cap M_0$ .

This can be proved similarly to [CLS11, Theorem 7.1.13]. Every  $n$ -dimensional cone  $\sigma \in \Sigma(n)$  corresponds to an  $n$ -dimensional face  $F_\sigma$  of  $\tau$ , which is contained in a hyperplane  $(u_\sigma + h_\sigma e_0^*)^\perp$  for some  $u_\sigma \in M$  and  $h_\sigma \in \mathbb{N}^+$ . The affine open subscheme  $\text{TV}_{\mathbb{C}}(\sigma)$  of the toric variety  $X = \text{TV}_{\mathbb{C}}(\Sigma)$  is isomorphic to the affine open subscheme of  $\text{Proj } \mathbb{C}[\tau^\vee \cap M_0]$  defined by the homogeneous element  $\chi^{u_\sigma + h_\sigma e_0^*}$  because there is a ring isomorphism

$$\mathbb{C}[\tau^\vee \cap M_0]_{(\chi^{u_\sigma + h_\sigma e_0^*})} \xrightarrow{\sim} \mathbb{C}[\sigma^\vee \cap M] \quad (3.15)$$

which is defined by

$$\frac{\chi^{u+h_\sigma k e_0^*}}{(\chi^{u_\sigma + h_\sigma e_0^*})^k} \mapsto \chi^{u - k u_\sigma}$$

for  $u \in M$ ,  $k \in \mathbb{N}$  such that  $u + h_\sigma k e_0^* \in \tau^\vee \cap M_0$ .

In the following lemma we compare the homogeneous coordinate rings of a polarised toric variety and of its affine cone. We deduce an alternate description of closed subschemes of a polarised toric variety.

**Lemma 3.15.** *Let  $N$  be a lattice of rank  $n$ , let  $\tau$  be a  $(n+1)$ -dimensional strongly convex rational polyhedral cone in the lattice  $N_0 = N \oplus \mathbb{Z}e_0$  such that  $e_0 \in \text{int}(\tau)$ , and let  $(X, D)$  and  $(\Sigma, \varphi)$  be the pairs associated to  $\tau$  via Lemma 3.11. Consider the affine toric variety  $C = \text{Spec } \mathbb{C}[\tau^\vee \cap M_0]$ . Let  $S_X$  and  $S_C$  be the homogeneous coordinate rings of  $X$  and  $C$ , respectively.*

For every ray  $\rho \in \Sigma(1)$ , let  $\xi_\rho = b_\rho \rho - a_\rho e_0 \in \tau(1)$  be the corresponding ray of  $\tau$ , where  $\varphi(\rho) = a_\rho/b_\rho$  for  $a_\rho \in \mathbb{Z}$  and  $b_\rho \in \mathbb{N}^+$  such that  $\gcd(a_\rho, b_\rho) = 1$ . Consider the ring homomorphism  $S_X \rightarrow S_C$  given by  $x_\rho \mapsto (x_{\xi_\rho})^{b_\rho}$ .

Let  $J_X$  be a  $G_\Sigma$ -homogeneous ideal in  $S_X$  and let  $H \subseteq \mathbb{C}[\tau^\vee \cap M_0] \simeq (S_C)_0$  be the degree zero part of the ideal  $J_X S_C \subseteq S_C$ . If  $H$  is homogeneous with respect to the  $\mathbb{N}$ -grading of  $\mathbb{C}[\tau^\vee \cap M_0]$ , then the closed subscheme of  $X$  defined by the ideal  $J_X$  coincides with  $\text{Proj } \mathbb{C}[\tau^\vee \cap M_0]/H$ .

*Proof.* Fix a full dimensional cone  $\sigma \in \Sigma(n)$  and let  $u_\sigma \in M$  and  $h_\sigma \in \mathbb{N}^+$  be such that the hyperplane  $(u_\sigma + h_\sigma e_0^*)^\perp$  contains the corresponding face  $F_\sigma$  of  $\tau$ , as in Remark 3.14. We set  $\bar{u}_\sigma = u_\sigma + h_\sigma e_0^* \in M_0$  for brevity. We have to show that the ideal  $(J_X)_{(x^{\bar{u}_\sigma})} \subseteq (S_X)_{(x^{\bar{u}_\sigma})} \simeq \mathbb{C}[\sigma^\vee \cap M]$  is mapped to  $H_{(x^{\bar{u}_\sigma})}$  via the isomorphism (3.15).

Since  $\bar{u}_\sigma$  is zero on the face  $F_\sigma$  and strictly positive on  $\tau \setminus F_\sigma$ , a Cox coordinate  $x_\xi$  of  $C$  appear in the monomial  $x^{\bar{u}_\sigma} \in S_C$  if and only if  $\xi \notin F_\sigma$ . This implies that there is a ring homomorphism

$$(S_X)_{x^{\bar{u}_\sigma}} \longrightarrow (S_C)_{x^{\bar{u}_\sigma}} \quad (3.16)$$

that is the localisation of  $S_X \rightarrow S_C$  defined above. At this point it is not difficult to show that there is a commutative diagram of rings

$$\begin{array}{ccccc}
 \mathbb{C}[\tau^\vee \cap M_0] & \xrightarrow{\text{Cox}_\tau} & (S_C)_0 & \hookrightarrow & S_C \\
 \downarrow & & \downarrow & & \downarrow \\
 \mathbb{C}[\tau^\vee \cap M_0]_{(x^{\bar{u}_\sigma})} & \hookrightarrow & \mathbb{C}[\tau^\vee \cap M_0]_{x^{\bar{u}_\sigma}} & \xrightarrow{\text{Cox}_\tau} & (S_C)_{x^{\bar{u}_\sigma}} \\
 \downarrow & & \downarrow & & \downarrow \\
 \mathbb{C}[\sigma^\vee \cap M] & \xrightarrow{\text{Cox}_\sigma} & (S_X)_{(x^{\bar{u}_\sigma})} & \hookrightarrow & (S_X)_{x^{\bar{u}_\sigma}} \\
 \downarrow & & \downarrow & & \downarrow \\
 \mathbb{C}[\sigma^\vee \cap M] & \xrightarrow{\text{Cox}_\sigma} & (S_X)_{(x^{\bar{u}_\sigma})} & \hookrightarrow & (S_X)_{x^{\bar{u}_\sigma}}
 \end{array}$$

$(3.15) \parallel$  on the left,  $(3.16) \parallel$  on the right, and a curved arrow from  $S_C$  to  $(S_X)_{x^{\bar{u}_\sigma}}$ .

where the equality symbols stand for isomorphisms. Now consider the ideal  $K = J_X(S_C)_{x^{\bar{u}_\sigma}} \subseteq (S_C)_{x^{\bar{u}_\sigma}}$ .

Since  $S_C$  is a finite free  $S_X$ -module,  $S_C$  is faithfully flat over  $S_X$ . Therefore, also the localised homomorphism (3.16) is faithfully flat. By [Mat89, Theorem 7.5(ii)] the contraction of  $K$  to  $(S_X)_{x^{\bar{u}_\sigma}}$  is the extension of  $J_X$ . This implies that  $(J_X)_{(x^{\bar{u}_\sigma})}$  is the contraction of  $K$  to  $(S_X)_{(x^{\bar{u}_\sigma})}$  along the homomorphisms in the diagram above.

On the other hand, it is clear that  $K$  is the extension of  $J_X S_C$  to  $(S_C)_{x^{\bar{u}_\sigma}}$ . Since  $x^{\bar{u}_\sigma}$  has degree zero with respect to the  $G_\tau$ -grading of  $S_C$ , it is not difficult to check that the extension of  $H = (J_X S_C) \cap (S_C)_0$  to  $(S_C)_{(x^{\bar{u}_\sigma})} \simeq \mathbb{C}[\tau^\vee \cap M_0]_{x^{\bar{u}_\sigma}}$  is the contraction of  $K$ . It follows that the ideal  $H_{(x^{\bar{u}_\sigma})}$  is the contraction of  $K$  to

$\mathbb{C}[\tau^\vee \cap M_0]_{(\chi^{\bar{u}\sigma})}$ .

Since the two ideals that must be checked to coincide are both contractions of the same ideal  $K$ , we are done.  $\square$

*Proof of Theorem 3.12(A).* By Theorem 3.4  $\tilde{\tau}$  is a  $(n+1+k)$ -dimensional strongly convex rational polyhedral cone in  $\tilde{N}_0$ . It is clear that  $e_0 \in \tilde{\tau}$ . Now we show that  $e_0$  is in the interior of  $\tilde{\tau}$ : it is enough to show that, if  $\tilde{u} = u + \sum_{i=0}^k h_i e_i^* \in \tilde{\tau}^\vee \cap \tilde{M}_0$  and  $h_0 = 0$ , then  $\tilde{u} = 0$ . Since  $\tau \subseteq \tilde{\tau}$ , we have that  $u$  is non-negative on  $\tau$ ; but  $e_0$  is in the interior of  $\tau$ , so  $u = 0$ . By evaluating  $\tilde{u} = \sum_{i=1}^k h_i e_i^*$  on  $Q_0 - e_1 - \cdots - e_k$ ,  $Q_1 + e_1, \dots, Q_k + e_k$ , we see  $h_1 = \cdots = h_k = 0$ . This proves that  $e_0$  lies in the interior of  $\tilde{\tau}$ .

Thanks to Remark 3.14  $X = \text{Proj } \mathbb{C}[\tau^\vee \cap M_0]$  and  $\tilde{X} = \text{Proj } \mathbb{C}[\tilde{\tau}^\vee \cap \tilde{M}_0]$ , where  $\mathbb{C}[\tau^\vee \cap M_0]$  and  $\mathbb{C}[\tilde{\tau}^\vee \cap \tilde{M}_0]$  are  $\mathbb{N}$ -graded via  $e_0$ . The ring homomorphism

$$\mathbb{C}[\tilde{\tau}^\vee \cap \tilde{M}_0] \longrightarrow \mathbb{C}[\tau^\vee \cap M_0], \quad (3.17)$$

which is induced by the inclusion  $\tau \hookrightarrow \tilde{\tau}$  and is surjective by the proof of Theorem 3.4, is clearly graded and induces a closed embedding  $\iota: X \hookrightarrow \tilde{X}$ . Using the isomorphism (3.15) it is not difficult to write down the formulae for the actions of the tori  $T_N$  and  $T_{\tilde{N}}$  on the affine charts of  $X$  and  $\tilde{X}$ , respectively. From these formulae it is possible to see that  $\iota$  is a toric morphism.

We have to prove that  $X$  coincides with the closed subscheme of  $\tilde{X}$  defined by the binomials (3.13). Let  $J_{\tilde{X}}$  be the  $G_{\tilde{\Sigma}}$ -homogeneous ideal generated by these binomials in the homogeneous coordinate ring  $S_{\tilde{X}}$  of  $\tilde{X}$ . Let  $J_{\tilde{C}} = J_{\tilde{X}} S_{\tilde{C}}$  be the extension of  $J_{\tilde{X}}$  to the total coordinate ring  $S_{\tilde{C}}$  of the affine cone  $\tilde{C} = \text{Spec } \mathbb{C}[\tau^\vee \cap \tilde{M}_0]$  via the ring homomorphism  $S_{\tilde{X}} \rightarrow S_{\tilde{C}}$  defined in Lemma 3.15. The ideal  $J_{\tilde{C}}$  is generated by the binomials

$$\prod_{\substack{\xi \in \tilde{\tau}(1): \\ \langle e_i^*, \xi \rangle > 0}} x_\xi^{\langle e_i^*, \xi \rangle} - \prod_{\substack{\xi \in \tilde{\tau}(1): \\ \langle e_i^*, \xi \rangle < 0}} x_\xi^{-\langle e_i^*, \xi \rangle} \quad \text{for } i = 1, \dots, k$$

in the Cox coordinates of  $\tilde{C}$ . By Theorem 3.4 the part of degree zero of  $J_{\tilde{C}}$  in the ring  $(S_{\tilde{C}})_0 \simeq \mathbb{C}[\tilde{\tau}^\vee \cap \tilde{M}_0]$  coincides with the kernel  $H$  of the ring surjection (3.17). By Lemma 3.15  $X = \text{Proj } \mathbb{C}[\tilde{\tau}^\vee \cap \tilde{M}_0]/H$  coincides with the closed subscheme of  $\tilde{X}$  defined by the ideal  $J_{\tilde{X}}$ .

The matrices  $\mathcal{M}_{\tilde{\Sigma}} = (\langle e_i^*, \rho \rangle)_{1 \leq i \leq k, \rho \in \tilde{\Sigma}(1)}$  and  $\mathcal{M}_{\tilde{\tau}} = (\langle e_i^*, \xi \rangle)_{1 \leq i \leq k, \xi \in \tilde{\tau}(1)}$  differ just by multiplication by a positive integer on each column, namely the numbers  $b_\rho$  defined in Lemma 3.15. From the proof of Lemma 3.8 we see that  $\mathcal{M}_{\tilde{\tau}}$  has rank  $k$

and each of its columns has at most one positive entry. Therefore also the matrix  $\mathcal{M}_{\Sigma}$  has these two properties. By Lemma 3.7 the binomials (3.13) form a regular sequence.  $\square$

The following two lemmata should be well known, but we have not been able to find an adequate reference for them.

**Lemma 3.16.** *Let  $(A, \mathfrak{m})$  be a noetherian local ring and let  $Y \rightarrow \operatorname{Spec} A$  be a proper morphism of schemes such that  $Y \times_{\operatorname{Spec} A} \operatorname{Spec} A/\mathfrak{m}^n \rightarrow \operatorname{Spec} A/\mathfrak{m}^n$  is flat for every  $n \in \mathbb{N}$ . Then  $Y \rightarrow \operatorname{Spec} A$  is flat.*

*Proof.* This proof relies on an argument that appears in [TV13, Proof of Proposition 6.51]. Let  $\pi$  denote the morphism  $Y \rightarrow \operatorname{Spec} A$ . We want to show that the set  $Z = \{y \in Y \mid \mathcal{O}_{Y,y} \text{ is not flat over } A\}$  is empty. By covering  $Y$  with open affine subschemes and by using [Mat89, Theorem 24.3], one can see that  $Z$  is closed in  $Y$ .

Assume by contradiction that  $Z$  is non-empty. Since  $\pi$  is closed, the set  $\pi(Z)$  is a closed non-empty subset of  $\operatorname{Spec} A$ . Therefore  $\mathfrak{m} \in \pi(Z)$ . Hence there exists  $y_0 \in Z$  such that  $\pi(y_0) = \mathfrak{m}$ . Let  $\operatorname{Spec} R$  be an affine open neighbourhood of  $y_0$  in  $Y$  and let  $B = \mathcal{O}_{Y,y_0}$  be the local ring of  $Y$  at  $y_0$ . We know that  $A/\mathfrak{m}^n \rightarrow R/\mathfrak{m}^n R$  is flat for every  $n \in \mathbb{N}$ . Therefore the local homomorphism  $A \rightarrow B$  is such that  $A/\mathfrak{m}^n \rightarrow B/\mathfrak{m}^n B$  is flat for every  $n \in \mathbb{N}$ . By the local flatness criterion ([Mat89, Theorem 22.3])  $A \rightarrow B$  is flat. But this is absurd because  $y_0 \in Z$ .  $\square$

**Lemma 3.17.** *Let  $S$  be a noetherian scheme and let  $Y \rightarrow S$  be a scheme morphism of finite type such that  $Y \times_S \operatorname{Spec} \mathcal{O}_{S,s} \rightarrow \operatorname{Spec} \mathcal{O}_{S,s}$  is flat for some point  $s \in S$ . Then there exists an open neighbourhood  $U$  of  $s$  in  $S$  such that  $Y \times_S U \rightarrow U$  is flat.*

*Proof.* Since the problem is local and  $Y \rightarrow S$  is quasi-compact, we may assume  $S = \operatorname{Spec} A$ ,  $Y = \operatorname{Spec} B$  and  $s = \mathfrak{m}$  for some noetherian ring  $A$ , some finitely generated  $A$ -algebra  $B$  and some prime ideal  $\mathfrak{m}$  of  $A$ . We know that  $B \otimes_A A_{\mathfrak{m}}$  is flat over  $A_{\mathfrak{m}}$ . Let us consider the set

$$V = \{P \in \operatorname{Spec} B \mid B_P \text{ is flat over } A_{P \cap A}\} = \{P \in \operatorname{Spec} B \mid B_P \text{ is flat over } A\},$$

which is open in  $\operatorname{Spec} B$  by [Mat89, Theorem 24.3]. The equality above holds by transitivity of flatness and [Mat89, Theorem 7.1].

We identify  $\operatorname{Spec}(B \otimes_A A_{\mathfrak{m}})$  with the set of primes  $P \in \operatorname{Spec} B$  such that  $P \cap A \subseteq \mathfrak{m}$ . If  $P \in \operatorname{Spec} B$  is such that  $P \cap A \subseteq \mathfrak{m}$ , then by [Mat89, Theorem 7.1] from the flatness of  $B \otimes_A A_{\mathfrak{m}}$  over  $A_{\mathfrak{m}}$  we deduce that  $B_P$  is flat over  $(A_{\mathfrak{m}})_{(P \cap A)A_{\mathfrak{m}}} = A_{P \cap A}$ . This shows that  $\operatorname{Spec}(B \otimes_A A_{\mathfrak{m}})$  is contained in  $V$ .

Consider the set  $A \setminus \mathfrak{m}$  endowed with the order relation  $\leq$  such that  $f \leq g$  if and only if  $g \in \sqrt{Af}$ . If  $f \leq g$ , there is the localisation map  $A_f \rightarrow A_g$ , given by the restriction of the structure sheaf of  $\text{Spec } A$  from the principal open subset defined by  $f$  to the principal open subset defined by  $g$ . The rings  $A_f$  as  $f$  runs in  $A \setminus \mathfrak{m}$  form a direct system and the local ring  $A_{\mathfrak{m}}$  is the direct limit of this system. Since tensor products and direct limits commute,  $B \otimes_A A_{\mathfrak{m}}$  is the limit of  $B_f$  as  $f \in A \setminus \mathfrak{m}$ . We are in the situation of inverse limits of affine schemes studied in [Gro66, §8], i.e.  $\text{Spec}(B \otimes_A A_{\mathfrak{m}})$  is the projective limit of the affine schemes  $\text{Spec } B_f$  as  $f$  runs in  $A \setminus \mathfrak{m}$ .

For every  $f \in A \setminus \mathfrak{m}$ , consider the set  $E_f = V \cap \text{Spec } B_f$ , which is open in  $\text{Spec } B_f$  because  $V$  is open in  $\text{Spec } B$ . Since  $\text{Spec}(B \otimes_A A_{\mathfrak{m}})$  is contained in  $V$ , the set  $E = V \cap \text{Spec}(B \otimes_A A_{\mathfrak{m}})$  coincides with  $\text{Spec}(B \otimes_A A_{\mathfrak{m}})$ . Since  $E$  is the limit of the  $E_f$ 's, by [Gro66, Corollaire 8.3.5] we have that there exists  $f_0 \in A \setminus \mathfrak{m}$  such that  $E_{f_0} = \text{Spec } B_{f_0}$ . This implies that  $B_{f_0}$  is flat over  $A_{f_0}$ . Therefore we may take  $U = \text{Spec } A_{f_0}$ .  $\square$

*Proof of Theorem 3.12(B).* The proof of the fact that the trinomials (3.14) are elements of  $\mathbb{C}[t_1, \dots, t_k][x_\rho \mid \rho \in \tilde{\Sigma}(1)]$  is completely analogous to what is done in the proof of Theorem 3.4(B) and will be omitted.

Let  $\mathcal{X}$  be the closed subscheme of  $\tilde{X} \times_{\text{Spec } \mathbb{C}} \mathbb{A}_{\mathbb{C}}^k$  defined by the homogeneous ideal generated by the trinomials (3.14). The composition  $\mathcal{X} \hookrightarrow \tilde{X} \times_{\text{Spec } \mathbb{C}} \mathbb{A}_{\mathbb{C}}^k \rightarrow \mathbb{A}_{\mathbb{C}}^k$  is a scheme morphism such that its fibre over  $O \in \mathbb{A}_{\mathbb{C}}^k$  is  $X$  and the fibred product  $\mathcal{X} \times_{\mathbb{A}_{\mathbb{C}}^k} \text{Spec } \mathbb{C}[t_1, \dots, t_k]/\mathfrak{q}$  is flat over  $\mathbb{C}[t_1, \dots, t_k]/\mathfrak{q}$  for every  $(t_1, \dots, t_k)$ -primary ideal  $\mathfrak{q}$  of  $\mathbb{C}[t_1, \dots, t_k]$ . If  $A = \mathbb{C}[t_1, \dots, t_k]_{(t_1, \dots, t_k)}$  is the local ring of  $\mathbb{A}_{\mathbb{C}}^k$  at the origin  $O$ , by Lemma 3.16 the morphism  $\mathcal{X} \times_{\mathbb{A}_{\mathbb{C}}^k} \text{Spec } A \rightarrow \text{Spec } A$  is flat, and consequently it induces a deformation of  $X$  over  $\hat{A} = \mathbb{C}[[t_1, \dots, t_k]]$ . By Lemma 3.17 we may find an open neighbourhood  $U \subseteq \mathbb{A}_{\mathbb{C}}^k$  of  $O$  such that  $\mathcal{X} \times_{\mathbb{A}_{\mathbb{C}}^k} U$  is flat over  $U$ .  $\square$

### 3.5. Mutations induce deformations

It was observed by Ilten [Ilt12] that if two Fano polytopes  $P$  and  $P'$  in  $N_{\mathbb{R}}$  are related by a combinatorial mutation (see Definition 1.15) then the corresponding toric Fano varieties  $X_P$  and  $X_{P'}$  are two closed fibres of a flat family over  $\mathbb{P}^1$ . Ilten's construction relies on the deformations of T-varieties, which are a generalised notion of toric varieties (see [AH06, AHS08, AIP<sup>+</sup>12, IV12]).

In what follows we will be more explicit than Ilten, by using Cox coordinates and giving explicit equations. In the following theorem we will show that  $X_P$  and  $X_{P'}$  are two fibres of the flat family of divisors defined by a trinomial in the Cox

coordinates of a projective toric variety of dimension  $\dim X_P + 1$ . When  $X_P$  is a toric del Pezzo surface, a slight variation of this construction was pursued by Corti in [ACC<sup>+</sup>16, Lemma 7]. The rays of the fan of  $\tilde{X}$  have been suggested to us by Thomas Prince. Our proof relies on Theorem 3.12 and Remark 3.13.

**Theorem 3.18.** *Let  $P \subseteq N_{\mathbb{R}}$  be a Fano polytope and  $w \in M$  be a primitive vector. Let  $F$  be a factor for  $P$  with respect to  $w$  and let  $P' = \text{mut}_w(P, F)$  be the mutated polytope. Let  $X_P$  and  $X_{P'}$  be the toric Fano varieties associated to  $P$  and  $P'$  respectively. Set*

$$\begin{aligned} \text{vert}(P)^{\geq 0} &= \text{vert}(P) \cap \{v \in N \mid \langle w, v \rangle \geq 0\}, \\ \text{vert}(P')^{< 0} &= \text{vert}(P') \cap \{v \in N \mid \langle w, v \rangle < 0\}. \end{aligned}$$

Consider the lattice  $\tilde{N} = N \oplus \mathbb{Z}e_1$  and the polyhedron  $\tilde{Q} \subseteq \tilde{M}_{\mathbb{R}}$  defined by

$$\tilde{Q} = \left\{ u + ke_1^* \in \tilde{M}_{\mathbb{R}} \left| \begin{array}{l} \forall p \in \text{vert}(P)^{\geq 0}, \langle u, p \rangle + 1 \geq 0 \\ \forall p' \in \text{vert}(P')^{< 0}, \langle u, p' \rangle + 1 + k\langle w, p' \rangle \geq 0 \\ \forall f \in \text{vert}(F), \langle u, f \rangle + k \geq 0 \end{array} \right. \right\}.$$

Then  $\tilde{Q}$  is a full dimensional rational polytope and the rays of the normal fan  $\tilde{\Sigma}$  of  $\tilde{Q}$  are

- $p$  for  $p \in \text{vert}(P)^{\geq 0}$ ,
- $p' + \langle w, p' \rangle e_1$  for  $p' \in \text{vert}(P')^{< 0}$ ,
- $f + e_1$  for  $f \in \text{vert}(F)$ .

Moreover, if  $\tilde{X} = \text{TV}_{\mathbb{C}}(\tilde{\Sigma})$  is the toric variety associated to  $\tilde{\Sigma}$ , then by varying the coefficients of the trinomial

$$\prod_{p \in \text{vert}(P)^{\geq 0}} x_p^{\langle w, p \rangle} + \prod_{p' \in \text{vert}(P')^{< 0}} x_{p'}^{-\langle w, p' \rangle} + \prod_{f \in \text{vert}(F)} x_f$$

we get a family of closed subschemes of  $\tilde{X}$  over  $\mathbb{P}_{\mathbb{C}}^2$  such that the fibre over  $[0 : 1 : -1]$  is  $X_P$  and the fibre over  $[1 : 0 : -1]$  is  $X_{P'}$ .

*Proof.* Consider the cone  $\tau = \text{cone} \langle P + e_0 \rangle \subseteq (N_0)_{\mathbb{R}}$  and the polytope

$$G = \text{conv} \left\langle \bigcup_{h_{\min} \leq h < 0} \frac{G_h + e_0}{-h} \right\rangle.$$

It is obvious to see that the conditions (i)-(iv) in Remark 3.13 are satisfied. Let us prove (v). Each vertex of the polyhedron  $\tau \cap \{v + ke_0 \in (N_0)_{\mathbb{R}} \mid \langle w, v \rangle = -1\}$  is of the form  $-\langle w, p \rangle^{-1}(p + e_0)$  for some  $p \in \text{vert}(P)^{<0}$ . By (1.2) there exist  $g \in G_{\langle w, p \rangle}$  and  $f \in F$  such that  $p = g - \langle w, p \rangle f$ . This implies that

$$-\frac{p + e_0}{\langle w, p \rangle} = \frac{g + e_0}{-\langle w, p \rangle} + f \in G + F.$$

Now we can follow the procedure of Remark 3.13. We consider the cone  $\tilde{\tau} = \text{cone} \langle \tau, G - e_1, F + e_1 \rangle$  in the lattice  $\tilde{N}_0 = N \oplus \mathbb{Z}e_0 \oplus \mathbb{Z}e_1$ . By using (1.2) it is not difficult to show that  $\tilde{\tau}$  is generated by  $p + e_0$  for  $p \in \text{vert}(P)^{\geq 0}$ ,  $p' + e_0 + \langle w, p' \rangle e_1$  for  $p' \in \text{vert}(P)^{<0}$ , and  $f + e_1$  for  $f \in \text{vert}(F)$ . It is tedious but not difficult to show that these are the rays of  $\tilde{\tau}$ . This implies that  $\tilde{Q} = \tilde{\tau}^\vee \cap e_0^{-1}(1)$  and that the rays of  $\tilde{\Sigma}$  are the ones written down in the statement of the theorem.

The trinomial above is exactly the trinomial in Remark 3.13. Therefore we know that the fibre over  $[0 : 1 : -1]$  is  $X_P$ .

It remains to show that  $X_{P'}$  is the fibre over  $[1 : 0 : -1]$ . But this can be seen by using the inverse mutation from  $P'$  to  $P$  and by applying the automorphism of  $N \oplus \mathbb{Z}e_1$  given by  $v + ke_1 \mapsto v + (k + \langle w, v \rangle)e_1$ .  $\square$



# 4

## Non-smoothability for some toric threefolds

In this chapter we define  $A_n$ -bundles (Definition 4.1) and we give a cohomological obstruction for their smoothability (Corollary 4.6). We apply this criterion to a certain class of Gorenstein toric threefolds and we give an equivalent geometric condition on the fan (Proposition 4.9). Finally we show two Gorenstein toric Fano threefolds that are locally isomorphic, but one is smoothable and one is not (Examples 4.13 and 4.12).

### 4.1. Deformations of $A_n$ -bundles

We work over  $\mathbb{C}$ , but everything will hold over a field of characteristic zero or over a perfect field of large characteristic.

For any  $n \in \mathbb{N}^+$ , let  $A_n$  denote the toric surface singularity associated to the cone  $\langle (0, 1), (n + 1, 1) \rangle$  inside the lattice  $\mathbb{Z}^2$ , i.e. the affine hypersurface

$$A_n = \text{Spec } \mathbb{C}[x, y, z]/(xy - z^{n+1}).$$

There is an obvious embedding  $A_n \hookrightarrow \mathbb{A}^3$ , whose associated conormal sequence

produces a free resolution of  $\Omega_{A_n}^1$ :

$$0 \longrightarrow I_{A_n/\mathbb{A}^3}/I_{A_n/\mathbb{A}^3}^2 = \mathcal{O}_{A_n} \begin{pmatrix} y \\ x \\ -(n+1)z^n \end{pmatrix} \longrightarrow \Omega_{\mathbb{A}^3}^1|_{A_n} = \mathcal{O}_{A_n}^{\oplus 3} \longrightarrow \Omega_{A_n}^1 \longrightarrow 0 \quad (4.1)$$

where  $I_{A_n/\mathbb{A}^3}$  is the ideal of  $A_n$  in  $\mathbb{A}^3$ . This allows us to compute

$$\begin{aligned} \mathrm{Ext}_{\mathcal{O}_{A_n}}^1(\Omega_{A_n}^1, \mathcal{O}_{A_n}) &= \mathrm{coker} \left( \mathcal{O}_{A_n}^{\oplus 3} \xrightarrow{(y, x, -(n+1)z^n)} \mathcal{O}_{A_n} \right) \\ &= \mathcal{O}_{A_n}/(y, x, z^n) \\ &= \mathcal{O}_{D_n} \end{aligned}$$

where  $D_n \simeq \mathrm{Spec} \mathbb{C}[z]/(z^n)$  is the closed subscheme of  $A_n$  defined by the ideal generated by  $y$ ,  $x$  and  $z^n$ . Notice that  $D_n$  is the singular locus of  $A_n$  equipped with the schematic structure given by the second Fitting ideal of  $\Omega_{A_n}^1$ .

We want to define the notion of an  $A_n$ -bundle and globalise this computation of the Ext group. Informally, an  $A_n$ -bundle is a morphism  $Y \rightarrow S$  which, Zariski-locally, is the projection  $A_n \times S \rightarrow S$ . More precisely we have to insist that an  $A_n$ -bundle is a closed subscheme in a split vector bundle over  $S$  of rank 3.

**Definition 4.1.** An  $A_n$ -bundle over a  $\mathbb{C}$ -scheme  $S$  is a morphism of schemes  $\pi_Y: Y \rightarrow S$  such that there exist three line bundles  $\mathcal{L}_x, \mathcal{L}_y, \mathcal{L}_z \in \mathrm{Pic}(S)$ , a closed embedding of  $S$ -schemes

$$\iota: Y \hookrightarrow E = \mathbf{Spec}_S \mathrm{Sym}_{\mathcal{O}_S}^\bullet(\mathcal{L}_x \oplus \mathcal{L}_y \oplus \mathcal{L}_z)^\vee$$

of  $Y$  into the total space of  $\mathcal{L}_x \oplus \mathcal{L}_y \oplus \mathcal{L}_z$ , and an affine open cover  $\{S_i\}_i$  of  $S$  satisfying the following condition: for each  $i$ , there are trivializations  $\mathcal{L}_x|_{S_i} \simeq \mathcal{O}_{S_i}$ ,  $\mathcal{L}_y|_{S_i} \simeq \mathcal{O}_{S_i}$ ,  $\mathcal{L}_z|_{S_i} \simeq \mathcal{O}_{S_i}$  and a commutative diagram of  $S_i$ -schemes

$$\begin{array}{ccc} \pi_Y^{-1}(S_i) & \xrightarrow{\simeq} & \mathrm{Spec} \mathcal{O}_{S_i}(S_i)[x_i, y_i, z_i]/(x_i y_i - z_i^{n+1}) \\ \iota_{S_i} \downarrow & & \downarrow \\ \pi_E^{-1}(S_i) & \xrightarrow{\simeq} & \mathrm{Spec} \mathcal{O}_{S_i}(S_i)[x_i, y_i, z_i] = \mathbb{A}_{S_i}^3 \end{array}$$

where  $\pi_E$  denotes the projection  $E \rightarrow S$ , the coordinates  $x_i \in \Gamma(S_i, \mathcal{L}_x^\vee)$ ,  $y_i \in \Gamma(S_i, \mathcal{L}_y^\vee)$  and  $z_i \in \Gamma(S_i, \mathcal{L}_z^\vee)$  are the local sections corresponding to the trivializations above, the horizontal arrows are isomorphisms, the left vertical arrow is the restriction of the closed embedding  $\iota: Y \hookrightarrow E$ , and the right vertical arrow is the

base change of the standard embedding  $A_n \hookrightarrow \mathbb{A}^3$  to  $S_i$ .

**Remark 4.2.** A posteriori one can see that  $\mathcal{L}_x \otimes \mathcal{L}_y \simeq \mathcal{L}_z^{\otimes(n+1)}$ . This follows from the following easy fact in commutative algebra: let  $A$  be a ring and  $f \in A$  be an invertible element; if the ideal of  $A[x, y, z]$  generated by  $xy - z^{n+1}$  coincides with the ideal generated by  $xy - fz^{n+1}$ , then  $f = 1$ .

**Lemma 4.3.** *Let  $S$  be a scheme with a line bundle  $\mathcal{L} \in \text{Pic}(S)$ . Let  $D$  be the  $k$ th order thickening of the zero section of the total space of  $\mathcal{L}$ , i.e. the closed subscheme of  $\mathbf{Spec}_S \mathcal{S}ym_{\mathcal{O}_S}^\bullet \mathcal{L}^\vee$  locally defined by the equation  $x^{k+1} = 0$  where  $x$  is a nowhere vanishing local section of  $\mathcal{L}^\vee$ . Let  $\pi: D \rightarrow S$  be the projection. Then*

$$\pi_* \mathcal{O}_D = \bigoplus_{i=0}^k (\mathcal{L}^\vee)^{\otimes i}.$$

*Proof.* Let  $\{S_i\}_i$  be an affine open cover of  $S$  which trivializes  $\mathcal{L}$ . Let  $x_i \in \Gamma(S_i, \mathcal{L}^\vee)$  be a local coordinate. Then we have the isomorphism of  $S_i$ -schemes

$$\pi^{-1}(S_i) \simeq \text{Spec } \mathcal{O}_S(S_i)[x_i]/(x_i^{k+1}).$$

Therefore  $\pi_* \mathcal{O}_D|_{S_i}$  is the free  $\mathcal{O}_{S_i}$ -module with basis  $\{1, x_i, \dots, x_i^k\}$ , which is a local frame of  $\mathcal{O}_S \oplus \mathcal{L}^\vee \oplus \dots \oplus (\mathcal{L}^\vee)^{\otimes k}$ .

Another way to see this is to notice that  $D = \mathbf{Spec}_S(\mathcal{S}ym_{\mathcal{O}_S}^\bullet \mathcal{L}^\vee)/\mathcal{I}$ , and consequently  $\pi_* \mathcal{O}_D = (\mathcal{S}ym_{\mathcal{O}_S}^\bullet \mathcal{L}^\vee)/\mathcal{I}$ , where  $\mathcal{I} \subseteq \mathcal{S}ym_{\mathcal{O}_S}^\bullet \mathcal{L}^\vee$  is the ideal made up of elements of degree greater than  $k$ .  $\square$

**Proposition 4.4.** *Let  $S$  be a  $\mathbb{C}$ -scheme and  $\pi_Y: Y \rightarrow S$  be an  $A_n$ -bundle, with  $\mathcal{L}_x, \mathcal{L}_y, \mathcal{L}_z \in \text{Pic}(S)$  as in Definition 4.1. Then there is an isomorphism of  $\mathcal{O}_S$ -modules*

$$(\pi_Y)_* (\mathcal{E}xt_{\mathcal{O}_Y}^1(\Omega_{Y/S}^1, \mathcal{O}_Y)) \simeq \bigoplus_{2 \leq j \leq n+1} \mathcal{L}_z^{\otimes j}.$$

*Proof.* Assume we are in the setting of Definition 4.1, with projections  $\pi_Y: Y \rightarrow S$  and  $\pi_E: E \rightarrow S$ , closed embedding  $\iota: Y \hookrightarrow E$ , and a trivialising affine open cover  $\{S_i\}_i$  of  $S$  with local sections  $x_i, y_i, z_i$ .

We consider the conormal sequence of  $Y \xrightarrow{\iota} E \xrightarrow{\pi_E} S$ :

$$\mathcal{I}_{Y/E}/\mathcal{I}_{Y/E}^2 \longrightarrow \Omega_{E/S}^1|_Y \longrightarrow \Omega_{Y/S}^1 \longrightarrow 0, \quad (4.2)$$

where  $\mathcal{I}_{Y/E}$  is the ideal sheaf of the closed embedding  $\iota: Y \hookrightarrow E$ . We restrict this sequence to  $S_i$  and we get the conormal sequence of  $Y_i = \pi_Y^{-1}(S_i) \xrightarrow{\iota_{S_i}} E_i = \pi_E^{-1}(S_i) \rightarrow$

$S_i$ :

$$\mathcal{I}_{Y_i/E_i}/\mathcal{I}_{Y_i/E_i}^2 \longrightarrow \Omega_{E_i/S_i}^1|_{Y_i} \longrightarrow \Omega_{Y_i/S_i}^1 \longrightarrow 0; \quad (4.3)$$

this is the base change to  $S_i$  of (4.1), the conormal sequence of  $A_n \hookrightarrow \mathbb{A}^3 \rightarrow \text{Spec } \mathbb{C}$ . As  $S_i \rightarrow \text{Spec } \mathbb{C}$  is flat, we have that (4.3) is left exact for all  $i$ . As  $\{S_i\}_i$  is an open cover of  $S$ , we have that also (4.2) is left exact.

Since  $\pi_E: E \rightarrow S$  is the vector bundle whose sheaf of sections is  $\mathcal{L}_x \oplus \mathcal{L}_y \oplus \mathcal{L}_z$ , we have that  $\Omega_{E/S}^1 = \pi_E^*(\mathcal{L}_x \oplus \mathcal{L}_y \oplus \mathcal{L}_z)^\vee$ . Therefore  $\Omega_{E/S}^1|_Y = \pi_Y^*(\mathcal{L}_x \oplus \mathcal{L}_y \oplus \mathcal{L}_z)^\vee$ .

One can check that  $\mathcal{I}_{Y/E}/\mathcal{I}_{Y/E}^2 \simeq \pi_Y^*(\mathcal{L}_x \otimes \mathcal{L}_y)^\vee$ . On the intersection  $S_{ij} = S_i \cap S_j$  we have the equalities  $x_i = g_{ij}^x x_j$ ,  $y_i = g_{ij}^y y_j$ , and  $z_i = g_{ij}^z z_j$ , where  $g_{ij}^x, g_{ij}^y, g_{ij}^z \in \Gamma(S_{ij}, \mathcal{O}_S^*)$  are invertible functions such that  $g_{ij}^x g_{ij}^y = (g_{ij}^z)^{n+1}$  (by Remark 4.2). Then the restriction of the map

$$\pi_Y^*(\mathcal{L}_x \otimes \mathcal{L}_y)^\vee = \mathcal{I}_{Y/E}/\mathcal{I}_{Y/E}^2 \longrightarrow \Omega_{E/S}^1|_Y = \pi_Y^*(\mathcal{L}_x \oplus \mathcal{L}_y \oplus \mathcal{L}_z)^\vee$$

in (4.2) to  $Y_{ij} = \pi_Y^{-1}(S_{ij})$  produces the following commutative diagram.

$$\begin{array}{ccc} \mathcal{O}_{Y_{ij}} \begin{pmatrix} y_i \\ x_i \\ -(n+1)z_i^n \end{pmatrix} & \xrightarrow{\quad} & \mathcal{O}_{Y_{ij}}^{\oplus 3} \\ \downarrow g_{ij}^x g_{ij}^y & & \downarrow \text{diag}(g_{ij}^x, g_{ij}^y, g_{ij}^z) \\ \mathcal{O}_{Y_{ij}} \begin{pmatrix} y_j \\ x_j \\ -(n+1)z_j^n \end{pmatrix} & \xrightarrow{\quad} & \mathcal{O}_{Y_{ij}}^{\oplus 3} \end{array}$$

Therefore the sequence (4.2) becomes

$$0 \longrightarrow \pi_Y^*(\mathcal{L}_x \otimes \mathcal{L}_y)^\vee \longrightarrow \pi_Y^*(\mathcal{L}_x \oplus \mathcal{L}_y \oplus \mathcal{L}_z)^\vee \longrightarrow \Omega_{Y/S}^1 \longrightarrow 0,$$

which gives a locally free resolution of  $\Omega_{Y/S}^1$ . Hence

$$\begin{aligned} \mathcal{E}xt_{\mathcal{O}_Y}^1(\Omega_{Y/S}^1, \mathcal{O}_Y) &= \text{coker}(\pi_Y^*(\mathcal{L}_x \oplus \mathcal{L}_y \oplus \mathcal{L}_z) \longrightarrow \pi_Y^*(\mathcal{L}_x \otimes \mathcal{L}_y)) \\ &= \pi_Y^*(\mathcal{L}_x \otimes \mathcal{L}_y) \otimes_{\mathcal{O}_Y} \mathcal{O}_D \\ &= \pi_Y^*(\mathcal{L}_z)^{\otimes(n+1)} \otimes_{\mathcal{O}_Y} \mathcal{O}_D \end{aligned}$$

where  $D \hookrightarrow Y$  is the closed subscheme locally defined by  $x_i = y_i = z_i^n = 0$ . Denote with  $\pi_D: D \rightarrow S$  the projection. It is clear that  $D$  is the  $(n-1)$ th order thickening

of the zero section in the total space  $\mathcal{L}_z$  over  $S$ . By Lemma 4.3 we have

$$(\pi_D)_* \mathcal{O}_D = \bigoplus_{i=0}^{n-1} (\mathcal{L}_z^\vee)^{\otimes i}.$$

Thus

$$\begin{aligned} (\pi_Y)_* \mathcal{E}xt_{\mathcal{O}_Y}^1(\Omega_{Y/S}^1, \mathcal{O}_Y) &= (\pi_Y)_*(\pi_Y^* \mathcal{L}_z^{\otimes(n+1)} \otimes_{\mathcal{O}_Y} \mathcal{O}_D) \\ &= (\pi_D)_*(\pi_D^* \mathcal{L}_z^{\otimes(n+1)}) \\ &= (\pi_D)_* \mathcal{O}_D \otimes_{\mathcal{O}_S} \mathcal{L}_z^{\otimes(n+1)} \\ &= \bigoplus_{i=0}^{n-1} (\mathcal{L}_z^\vee)^{\otimes i} \otimes_{\mathcal{O}_S} \mathcal{L}_z^{\otimes(n+1)} \\ &= \bigoplus_{2 \leq j \leq n+1} \mathcal{L}_z^{\otimes j}. \end{aligned}$$

This concludes the proof of Proposition 4.4.  $\square$

The following lemma should be well known in deformation theory.

**Lemma 4.5.** *Let  $Y$  be a reduced  $\mathbb{C}$ -scheme. Assume that  $Y \rightarrow \text{Spec } \mathbb{C}$  is a local complete intersection morphism and that  $H^0(Y, \mathcal{E}xt_{\mathcal{O}_Y}^1(\Omega_Y^1, \mathcal{O}_Y)) = 0$ .*

*Then all infinitesimal deformations of  $Y$  are locally trivial. In particular, if  $Y$  is not smooth, then  $Y$  is not smoothable<sup>1</sup>.*

*Proof.* Let  $\mathcal{D}ef_Y$  be the functor of infinitesimal deformations of  $Y$ , i.e. the covariant functor from the category of local finite  $\mathbb{C}$ -algebras to the category of sets which maps  $A$  to the set of isomorphism classes of deformations of  $Y$  over  $\text{Spec } A$  and acts on arrows by base change. Consider the subfunctor  $\mathcal{D}ef'_Y \hookrightarrow \mathcal{D}ef_Y$  given by the locally trivial deformations. We refer the reader to [Ser06, §2.4] for details. We want to show that  $\mathcal{D}ef'_Y \hookrightarrow \mathcal{D}ef_Y$  is surjective; it is enough to show that it is smooth; hence it suffices to prove that it induces a surjection on tangent spaces and an injection on obstruction spaces (for example see [FM98, Lemma 6.1] or [Man09, Theorem 4.11]).

By [Ser06, Theorem 2.4.1(ii)] the tangent space of  $\mathcal{D}ef'_Y$  is  $H^1(Y, \mathcal{T}_Y)$ , where  $\mathcal{T}_Y = \mathcal{H}om_{\mathcal{O}_Y}(\Omega_Y^1, \mathcal{O}_Y)$  is the sheaf of derivations on  $Y$ . Since  $Y$  is reduced and generically smooth over  $\mathbb{C}$ , by [TV13, Theorem 3.2.3] the tangent space of  $\mathcal{D}ef_Y$  is  $\text{Ext}_{\mathcal{O}_Y}^1(\Omega_Y^1, \mathcal{O}_Y)$ . By [Ser06, Proposition 2.4.6] an obstruction space for  $\mathcal{D}ef'_Y$  is  $H^2(Y, \mathcal{T}_Y)$ . By [Ill71, Chapitre III, Théorème 2.1.7] an obstruction space for  $\mathcal{D}ef_Y$

<sup>1</sup>A scheme  $X$  of finite type over  $\mathbb{C}$  is called *smoothable* if there exists a scheme  $S$  of finite type over  $\mathbb{C}$  with a closed point  $0 \in S$  and a flat morphism  $\mathcal{X} \rightarrow S$  of finite type such that the fibre over 0 is isomorphic to  $X$  and every other fibre is smooth. The scheme  $S$  can be required to be a smooth affine curve over  $\mathbb{C}$ . See [Har10, §29] for details.

is  $\mathrm{Ext}_{\mathcal{O}_Y}^2(L_Y, \mathcal{O}_Y)$ , where  $L_Y$  is the cotangent complex of  $Y \rightarrow \mathrm{Spec} \mathbb{C}$ ; since  $Y$  is a local complete intersection, by [Ill71, Chapitre III, §3.2], this last Ext group is the same as  $\mathrm{Ext}_{\mathcal{O}_Y}^2(\Omega_Y^1, \mathcal{O}_Y)$ . Independently one can deduce this result without using the cotangent complex thanks to [Vis, Theorem 4.4].

The local-to-global spectral sequence for Ext gives the following five term exact sequence

$$0 \rightarrow H^1(\mathcal{T}_Y) \rightarrow \mathrm{Ext}^1(\Omega_Y, \mathcal{O}_Y) \rightarrow H^0(\mathcal{E}xt^1(\Omega_Y, \mathcal{O}_Y)) \rightarrow H^2(\mathcal{T}_Y) \rightarrow \mathrm{Ext}^2(\Omega_Y, \mathcal{O}_Y).$$

(See also [Har10, Exercise 5.7].) With the identifications above, the vanishing of  $H^0(\mathcal{E}xt^1(\Omega_Y, \mathcal{O}_Y))$  implies that  $\mathcal{D}ef'_Y \rightarrow \mathcal{D}ef_Y$  induces an isomorphism on tangent spaces and an injection on obstruction spaces.  $\square$

**Corollary 4.6.** *Let  $S$  be a smooth  $\mathbb{C}$ -scheme and  $\pi_Y: Y \rightarrow S$  be an  $A_n$ -bundle, with  $\mathcal{L}_x, \mathcal{L}_y, \mathcal{L}_z \in \mathrm{Pic}(S)$  as in Definition 4.1. Assume  $H^0(S, \mathcal{L}_z^{\otimes j}) = 0$  for all  $2 \leq j \leq n+1$ .*

*Then all infinitesimal deformations of  $Y$  are locally trivial. In particular,  $Y$  is not smoothable.*

*Proof.* As  $Y \rightarrow S$  is a Zariski-locally trivial fibration, the sequence of Kähler differentials of  $Y \rightarrow S \rightarrow \mathrm{Spec} \mathbb{C}$  is left exact and locally split:

$$0 \longrightarrow \pi_Y^* \Omega_S^1 \longrightarrow \Omega_Y^1 \longrightarrow \Omega_{Y/S}^1 \longrightarrow 0.$$

This implies that the dual sequence, i.e. the one obtained by applying  $\mathrm{Hom}_{\mathcal{O}_Y}(\cdot, \mathcal{O}_Y)$ , is exact. Therefore we have an exact sequence of  $\mathcal{O}_Y$ -modules

$$0 \longrightarrow \mathcal{E}xt_{\mathcal{O}_Y}^1(\Omega_{Y/S}^1, \mathcal{O}_Y) \longrightarrow \mathcal{E}xt_{\mathcal{O}_Y}^1(\Omega_Y^1, \mathcal{O}_Y) \longrightarrow \mathcal{E}xt_{\mathcal{O}_Y}^1(\pi_Y^* \Omega_S^1, \mathcal{O}_Y).$$

But the last sheaf is zero because  $S$  is smooth over  $\mathbb{C}$ . Therefore we have an isomorphism of  $\mathcal{O}_Y$ -modules between  $\mathcal{E}xt_{\mathcal{O}_Y}^1(\Omega_{Y/S}^1, \mathcal{O}_Y)$  and  $\mathcal{E}xt_{\mathcal{O}_Y}^1(\Omega_Y^1, \mathcal{O}_Y)$ . By Proposition 4.4 we deduce that

$$H^0(Y, \mathcal{E}xt_{\mathcal{O}_Y}^1(\Omega_Y^1, \mathcal{O}_Y)) = \bigoplus_{2 \leq j \leq n+1} H^0(S, \mathcal{L}_z^{\otimes j}) = 0.$$

Conclude with Lemma 4.5.  $\square$

## 4.2. Toric $A_n$ -bundles over $\mathbb{P}^1$

In this section we consider toric  $A_n$ -bundles over  $\mathbb{P}^1$ . They are normal Gorenstein toric threefolds whose associated fan  $\Sigma$  in the lattice  $N = \mathbb{Z}^3$  can be described as follows.

**Setup 4.7.** Fix  $n \in \mathbb{N}^+$ . Let  $\rho_{x_0}$ ,  $\rho_{x_1}$ ,  $\rho_u$  and  $\rho_v$  be primitive vectors in a rank 3 lattice  $N$  such that:

1. the segment  $\text{conv}\langle \rho_u, \rho_v \rangle$  contains precisely  $n + 2$  lattice points,
2. the triangle  $\text{conv}\langle \rho_{x_0}, \rho_u, \rho_v \rangle$  is an  $A_n$ -triangle at height 1,<sup>2</sup>
3. the triangle  $\text{conv}\langle \rho_{x_1}, \rho_u, \rho_v \rangle$  is an  $A_n$ -triangle at height 1,
4. the vectors  $\rho_{x_0}$  and  $\rho_{x_1}$  are in the two different half-spaces defined by the hyperplane  $\text{span}\langle \rho_u, \rho_v \rangle$ .<sup>3</sup>

Let  $\Sigma$  be the fan in  $N = \mathbb{Z}^3$  given by the faces of the two 3-dimensional cones  $\text{cone}\langle \rho_{x_0}, \rho_u, \rho_v \rangle$ ,  $\text{cone}\langle \rho_{x_1}, \rho_u, \rho_v \rangle$ . Let  $Y$  be the toric threefold associated to the fan  $\Sigma$ .

**Lemma 4.8.** *After a  $\text{GL}_3(\mathbb{Z})$ -transformation, we may assume that*

$$\begin{aligned}\rho_{x_0} &= (a, b, -1) \\ \rho_{x_1} &= (0, 0, 1) \\ \rho_u &= (1, 0, 0) \\ \rho_v &= (-n, n + 1, 0)\end{aligned}$$

for some  $a, b \in \mathbb{Z}$ .

*Proof.* Let  $\hat{\rho} \in N$  be the lattice point on the segment between  $\rho_u$  and  $\rho_v$  which is the closest one to  $\rho_u$ . The triangle with vertices  $\rho_u, \rho_{x_1}, \hat{\rho}$  is an empty triangle at height 1, so  $\{\rho_u, \rho_{x_1}, \hat{\rho}\}$  is a basis of  $N$ . Without loss of generality we may assume that  $\rho_u = (1, 0, 0)$ ,  $\hat{\rho} = (0, 1, 0)$  and  $\rho_{x_1} = (0, 0, 1)$ . Since on the edge between  $\rho_u$  and  $\rho_v$  there are  $n + 2$  lattice points, we have  $\rho_v = \rho_u + (n + 1)(\hat{\rho} - \rho_u) = (-n, n + 1, 0)$ .

<sup>2</sup>Here we mean that there exists an element  $w \in M = \text{Hom}_{\mathbb{Z}}(N, \mathbb{Z})$  such that  $\text{conv}\langle \rho_{x_0}, \rho_u, \rho_v \rangle$  is contained in the hyperplane  $H_{w,1} = \{n \in N_{\mathbb{R}} \mid \langle w, n \rangle = 1\}$  and in the affine lattice  $H_{w,1} \cap N \simeq \mathbb{Z}^2$  is an  $A_n$ -triangle, i.e.  $\text{Aff}(\mathbb{Z}^2)$ -equivalent to  $\text{conv}\langle (0, 0), (0, 1), (n + 1, 1) \rangle$ . See also Definition 5.4.

<sup>3</sup>Here we mean that there exists  $w \in M = \text{Hom}_{\mathbb{Z}}(N, \mathbb{Z})$  such that  $\langle w, \rho_u \rangle = \langle w, \rho_v \rangle = 0$  and  $\langle w, \rho_{x_0} \rangle \cdot \langle w, \rho_{x_1} \rangle < 0$ .

Assume  $\rho_{x_0} = (a, b, c)$  for some  $a, b, c \in \mathbb{Z}$ . Since  $\rho_u, \hat{\rho}, \rho_{x_0}$  are the vertices of an empty triangle at height 1, they constitute a basis of  $N$ . Therefore  $c = \det(\rho_u | \hat{\rho} | \rho_{x_0}) = \pm 1$ .

Since  $\rho_{x_0}$  and  $\rho_{x_1}$  have to be in the two different half-spaces in which the hyperplane span  $\langle \rho_u, \rho_v \rangle = (0, 0, 1)^\perp$  divides  $N_{\mathbb{R}}$ , we have  $c < 0$ , so  $c = -1$ .  $\square$

Thanks to the lemma above, the ray map  $\mathbb{Z}^4 \rightarrow N = \mathbb{Z}^3$  of  $Y$  is given by the matrix

$$\begin{pmatrix} a & 0 & 1 & -n \\ b & 0 & 0 & n+1 \\ -1 & 1 & 0 & 0 \end{pmatrix}.$$

One can see that the ideal of  $\mathbb{Z}$  generated by the  $2 \times 2$  minors is  $\mathbb{Z}$  itself and the ideal generated by the  $3 \times 3$  minors is  $r\mathbb{Z}$ , where  $r = \gcd(n+1, b) > 0$ . Let  $p, q \in \mathbb{Z}$  be such that  $b = rp$  and  $n+1 = rq$ . The kernel of the ray map is generated by the primitive vector  $(q, q, -np - aq, -p)$ . By Bézout let  $s, t \in \mathbb{Z}$  be such that  $sp + tq = 1$ . The cokernel of the transpose of the ray map is the homomorphism  $\mathbb{Z}^4 \rightarrow \mathbb{Z} \oplus \mathbb{Z}/r\mathbb{Z}$  given by the matrix

$$\begin{pmatrix} q & q & -qa - pn & -p \\ \bar{s} & \bar{s} & -\bar{s}a + \bar{t}n & \bar{t} \end{pmatrix},$$

where  $\bar{\cdot}$  denotes the reduction modulo  $r$ .

Via the divisor sequence (see (2.6)) one can see that the divisor class group of  $Y$  is isomorphic to  $\mathbb{Z} \oplus \mathbb{Z}/r\mathbb{Z}$ . Let the group

$$G = \{ (\lambda^q \varepsilon^s, \lambda^q \varepsilon^s, \lambda^{-qa-pn} \varepsilon^{-sa+tn}, \lambda^{-p} \varepsilon^t) \in \mathbb{G}_m^4 \mid \lambda \in \mathbb{G}_m, \varepsilon \in \mu_r \}$$

act linearly on  $\mathbb{A}^4$ ; then  $Y$  is the quotient of  $\mathbb{A}^4 \setminus V(x_0, x_1)$  with respect to this action. Let  $x_0, x_1, u, v$  be the Cox coordinates of  $Y$  associated to the rays  $\rho_{x_0}, \rho_{x_1}, \rho_u, \rho_v$ , respectively. Consider the morphism  $\pi_Y: Y \rightarrow \mathbb{P}^1$  defined by  $[x_0 : x_1 : u : v] \mapsto [x_0 : x_1]$ .

We consider the following integers

$$\begin{aligned} d_x &= b - (n+1)(a+b) \\ d_y &= -b \\ d_z &= -a - b \end{aligned}$$

and we consider the line bundles  $\mathcal{L}_x = \mathcal{O}_{\mathbb{P}^1}(d_x)$ ,  $\mathcal{L}_y = \mathcal{O}_{\mathbb{P}^1}(d_y)$ ,  $\mathcal{L}_z = \mathcal{O}_{\mathbb{P}^1}(d_z)$  and the sheaf  $\mathcal{E} = \mathcal{O}_{\mathbb{P}^1}(d_y) \oplus \mathcal{O}_{\mathbb{P}^1}(d_z) \oplus \mathcal{O}_{\mathbb{P}^1}(d_t)$  on  $\mathbb{P}^1$ . Let  $\pi_E: E \rightarrow \mathbb{P}^1$  be the total space of  $\mathcal{E}$  over  $\mathbb{P}^1$ .  $E$  is the quotient  $\mathbb{A}^5 \setminus V(x_0, x_1)$  with respect to the action of  $\mathbb{G}_m$



with weights  $(1, 1, d_y, d_z, d_t)$ . It is easy to check that the map  $\iota: Y \rightarrow E$  given by  $[x_0 : x_1 : u : v] \mapsto [x_0 : x_1 : u^{n+1} : v^{n+1} : uv]$  is a closed embedding, locally defined by  $xy - z^{n+1} = 0$ . So  $\pi_Y: Y \rightarrow \mathbb{P}^1$  is an  $A_n$ -bundle and we are in the situation of Definition 4.1.

If  $d_z < 0$  then  $\mathcal{L}_z$  is a negative line bundle over  $\mathbb{P}^1$  and consequently, by Corollary 4.6, every infinitesimal deformation of  $Y$  is locally trivial and  $Y$  is not smoothable. The condition  $-(a + b) = d_z < 0$  is a geometric condition on the vectors  $\rho_{x_0}, \rho_{x_1}, \rho_u, \rho_v$ , as follows. If we assume the equalities of Lemma 4.8 we see that the triangle  $\text{conv} \langle \rho_{x_1}, \rho_u, \rho_v \rangle$  is contained in the hyperplane  $H_{(1,1,1),1}$  and that  $a + b > 0$  is equivalent to  $\langle (1, 1, 1), \rho_{x_0} \rangle \geq 0$ . Notice that this condition is symmetric between  $\rho_{x_0}$  and  $\rho_{x_1}$ . Thus we have proved the following proposition.

**Proposition 4.9.** *Let  $n \in \mathbb{N}^+$ ,  $\rho_{x_0}, \rho_{x_1}, \rho_u, \rho_v \in N$  and  $Y$  be as in Setup 4.7. Let  $w \in M = \text{Hom}_{\mathbb{Z}}(N, \mathbb{Z})$  be such that  $\langle w, \rho_{x_1} \rangle = \langle w, \rho_u \rangle = \langle w, \rho_v \rangle = 1$ . Assume that  $\langle w, \rho_{x_0} \rangle \geq 0$ .*

*Then  $H^0(Y, \mathcal{E}xt_{\mathcal{O}_Y}^1(\Omega_Y^1, \mathcal{O}_Y)) = 0$ , every infinitesimal deformation of  $Y$  is locally trivial, and  $Y$  is not smoothable.*

### 4.3. Deformations of some toric threefolds

Now we want to apply the results of §4.2 to some more complicated toric threefolds, namely to the toric threefolds such that the singular locus has an open neighbourhood isomorphic to a toric  $A_n$ -bundle over  $\mathbb{P}^1$ .

Let  $X$  be a toric  $\mathbb{Q}$ -factorial threefold such that the singular locus of  $X$ , equipped with its reduced structure, is isomorphic to  $\mathbb{P}^1$ . This means that all cones of the fan of  $X$  are smooth with the exceptions of three cones: a 2-dimensional cone  $\text{cone} \langle \rho_u, \rho_v \rangle$  and two 3-dimensional cones  $\text{cone} \langle \rho_{x_0}, \rho_u, \rho_v \rangle$ ,  $\text{cone} \langle \rho_{x_1}, \rho_u, \rho_v \rangle$ , where  $\rho_u, \rho_v, \rho_{x_0}, \rho_{x_1}$  are the primitive generators of some rays of the fan of  $X$ .

If we assume that  $X$  is Gorenstein and that the triangles  $\text{conv} \langle \rho_{x_0}, \rho_u, \rho_v \rangle$  and  $\text{conv} \langle \rho_{x_1}, \rho_u, \rho_v \rangle$  do not contain any interior point, then  $\rho_{x_0}, \rho_{x_1}, \rho_u, \rho_v$  satisfy the conditions 1–4 of Setup 4.7 for a unique  $n \geq 1$ . This implies that there exists a toric open embedding  $Y \hookrightarrow X$  such that  $Y$  is a toric  $A_n$ -bundle over  $\mathbb{P}^1$  and  $Y$  contains the singular locus of  $X$ . Since the sheaf  $\mathcal{E}xt_{\mathcal{O}_X}^1(\Omega_X^1, \mathcal{O}_X)$  is supported on the singular locus of  $X$ , its global sections coincide with the global sections of  $\mathcal{E}xt_{\mathcal{O}_Y}^1(\Omega_Y^1, \mathcal{O}_Y)$ . Therefore, thanks to Proposition 4.9 and to Lemma 4.5, we have a sufficient criterion, in terms of the geometry of vectors  $\rho_{x_0}, \rho_{x_1}, \rho_u, \rho_v$ , for  $X$  having only locally trivial infinitesimal deformations, and consequently for the non-smoothability of  $X$ .

**Remark 4.10.** If  $X$  is Fano, i.e. the fan of  $X$  is complete and the primitive generators of the rays of the fan are the vertices of a polytope, and  $w \in M$  is as in Proposition 4.9, then  $\langle w, \rho_{x_0} \rangle \leq 0$ .

**Remark 4.11.** Out of the 4319 reflexive Fano polytopes of dimension 3, there are 27 polytopes  $P$  such that the toric variety  $X_P$  associated to the spanning fan of  $P$  has a singular locus isomorphic to  $\mathbb{P}^1$  and there is an open neighbourhood of the singular locus that is an  $A_n$ -bundle over  $\mathbb{P}^1$ , for some  $n \geq 1$ . Using the criterion above we can deduce that 10 out of these 27 toric varieties have only locally trivial deformations.

**Example 4.12.** In the lattice  $N = \mathbb{Z}^3$  we consider the reflexive polytope  $P$  that is the convex hull of the columns of the matrix

$$\begin{bmatrix} 1 & 0 & -2 & 0 & 0 \\ 0 & 1 & -1 & 0 & 1 \\ 0 & 0 & 0 & 1 & -1 \end{bmatrix}.$$

Let  $X$  be the toric Fano threefold associated to the spanning fan of  $P$ . We have that  $X$  is a Gorenstein  $\mathbb{Q}$ -factorial variety, the singular locus  $C = \text{Sing}(X)$  is a curve isomorphic to  $\mathbb{P}^1$ , and there exists an open neighbourhood  $Y$  of  $C$  in  $X$  which is an  $A_1$ -bundle. Using the techniques of §4.2 we can see that  $\mathcal{E}xt_{\mathcal{O}_X}^1(\Omega_X^1, \mathcal{O}_X) \simeq \mathcal{O}_C(-2)$ . This implies that  $H^0(X, \mathcal{E}xt_{\mathcal{O}_X}^1(\Omega_X^1, \mathcal{O}_X)) = 0$  and, by Lemma 4.5, that every infinitesimal deformation of  $X$  is locally trivial and that  $X$  is not smoothable.

**Example 4.13.** Let  $P$  be the convex hull of the columns of the matrix

$$\begin{bmatrix} 0 & 1 & 0 & -1 & -1 \\ 0 & 0 & 1 & -1 & -1 \\ 1 & 0 & 0 & -1 & 1 \end{bmatrix}$$

Let  $X$  be the toric Fano threefold associated to the spanning fan of  $P$ . We have that  $X$  is a Gorenstein  $\mathbb{Q}$ -factorial variety, the singular locus  $C = \text{Sing}(X)$  is a curve isomorphic to  $\mathbb{P}^1$ , and there exists an open neighbourhood  $Y$  of  $C$  in  $X$  which is an  $A_1$ -bundle. Using the techniques of §4.2 we can see that  $\mathcal{E}xt_{\mathcal{O}_X}^1(\Omega_X^1, \mathcal{O}_X) \simeq \mathcal{O}_C(2)$ . This implies that  $h^0(X, \mathcal{E}xt_{\mathcal{O}_X}^1(\Omega_X^1, \mathcal{O}_X)) = 3$ .

Using the techniques of §3.5, one can embed  $X$  into a Gorenstein Fano fourfold as a Cartier divisor and then smooth  $X$  in its linear system.

**Remark 4.14.** The two Fano toric varieties appearing in Examples 4.12 and 4.13 are locally isomorphic; but, as proved above, one is not smoothable and the other is.

This discrepancy is reflected at the level of maximally mutable Laurent polynomials (cf. [KT]). In fact, on the first polytope there is a positive dimensional family of maximally mutable Laurent polynomials, whereas on the second one there is only one.

**Remark 4.15.** More generally, one can consider the toric Gorenstein Fano threefolds  $X$  such that there exists a toric open immersion  $Y \hookrightarrow X$  where  $Y$  is a toric  $A_n$ -bundle over  $\mathbb{P}^1$ . If the condition of Proposition 4.9 is satisfied, then  $Y$  has only locally trivial deformations and consequently  $X$  is not smoothable.

In this way we can prove that the following<sup>4</sup> 273 toric Gorenstein Fano threefolds are not smoothable: 15, 16, 36, 41, 45, 53, 58, 59, 61, 65, 66, 102, 105, 110, 111, 112, 113, 116, 117, 124, 125, 128, 135, 141, 142, 144, 146, 147, 148, 149, 152, 162, 172, 179, 183, 189, 192, 193, 197, 230, 236, 244, 248, 261, 268, 271, 272, 277, 278, 279, 280, 281, 282, 286, 288, 290, 292, 302, 310, 324, 325, 327, 331, 332, 333, 334, 335, 337, 340, 343, 347, 349, 351, 355, 356, 358, 361, 362, 386, 399, 400, 407, 443, 445, 448, 452, 453, 456, 457, 463, 467, 487, 490, 496, 497, 499, 501, 502, 505, 507, 508, 509, 511, 512, 516, 523, 540, 545, 550, 563, 569, 577, 579, 581, 582, 583, 594, 599, 600, 601, 605, 606, 617, 629, 633, 658, 670, 671, 672, 674, 679, 682, 687, 705, 760, 764, 770, 771, 780, 781, 786, 787, 792, 797, 799, 809, 811, 812, 815, 816, 824, 859, 865, 868, 873, 875, 878, 883, 884, 889, 891, 892, 893, 894, 895, 902, 905, 929, 956, 960, 965, 987, 1003, 1004, 1006, 1011, 1021, 1038, 1045, 1051, 1156, 1160, 1168, 1175, 1177, 1199, 1203, 1209, 1216, 1217, 1225, 1232, 1234, 1251, 1252, 1253, 1255, 1256, 1260, 1262, 1265, 1275, 1286, 1287, 1293, 1300, 1305, 1308, 1324, 1327, 1351, 1371, 1383, 1398, 1533, 1545, 1550, 1551, 1554, 1561, 1579, 1589, 1613, 1614, 1615, 1620, 1637, 1638, 1656, 1665, 1666, 1671, 1686, 1690, 1693, 1697, 1711, 1747, 1748, 1760, 1763, 1989, 2000, 2001, 2027, 2045, 2051, 2052, 2068, 2071, 2072, 2076, 2084, 2096, 2098, 2102, 2379, 2380, 2385, 2403, 2405, 2423, 2424, 2425, 2427, 2738, 2777, 2778, 2792, 3047, 3057, 3063, 3064.

---

<sup>4</sup>We use the classification of reflexive 3-dimensional polytopes by Kreuzer and Skarke [KS98], but we use the IDs that appear in <http://www.grdb.co.uk>.



# 5

## Deformations of affine toric varieties à la Gross–Siebert

In this chapter we discuss an approach, inspired by the Gross–Siebert program, to study deformations of affine Gorenstein toric pairs of dimension 3. We recall the definition of Gorenstein toric singularities in §5.1. We treat the easier case of surfaces in §5.2. In §5.3, we give a construction of an initial scattering diagram, which is the starting point of the Kontsevich–Soibelman–Gross–Siebert algorithm, in the case of 3-folds and we formulate a conjecture that relates Minkowski decompositions to deformations. In §5.4 we give two examples.

### 5.1. Gorenstein toric singularities

We start by recalling what a Gorenstein cone is.

**Definition 5.1.** Let  $N$  be a lattice and  $M = \text{Hom}_{\mathbb{Z}}(N, \mathbb{Z})$  be its dual. A *Gorenstein cone* inside  $N$  is a full dimensional strongly convex rational polyhedral cone  $\sigma$  inside  $N$  such that there exists  $v_0 \in M$  such that for every  $\rho$  primitive generator of a ray of  $\sigma$  we have  $\langle v_0, \rho \rangle = -1$ .

If  $\sigma$  is a Gorenstein cone, we have that

$$X = \text{TV}_{\mathbb{C}}(\sigma) = \text{Spec } \mathbb{C}[\sigma^{\vee} \cap M]$$

is a Gorenstein affine toric variety with no torus factors. We say that  $X$  is a *Gorenstein toric singularity*. The toric boundary of  $X$  is denoted by  $\partial X$  and is an effective reduced Cartier divisor, namely

$$\partial X = \text{Spec } \mathbb{C}[\sigma^\vee \cap M]/(\chi^{-v_0}).$$

The usual definition of Gorenstein cone does not require that  $\sigma$  is full dimensional, but here we do insist that  $\sigma$  is full dimensional as we are not interested in torus factors.

If  $\sigma$  is a Gorenstein cone of dimension  $n$ , then the primitive generators of the rays of  $\sigma$  lie on the hyperplane  $H_{v_0, -1}$  and they are the vertices of an  $(n-1)$ -dimensional lattice polytope  $Q$ . By using the fact that the short exact sequence

$$0 \longrightarrow v_0^\perp \longrightarrow N \xrightarrow{-v_0} \mathbb{Z} \longrightarrow 0$$

splits we have that under the isomorphism  $N \simeq v_0^\perp \oplus \mathbb{Z}$  the cone  $\sigma$  is  $\text{cone}\langle Q \times \{1\} \rangle$ , where  $Q$  is the  $(n-1)$ -dimensional lattice polytope above. The polytope  $Q$  is well-defined only up to translation, because of the choice of the splitting of the short exact sequence above, or equivalently the choice of an element of  $H_{v_0, -1} \cap N$ . We say that  $\sigma$  is the *cone over the polytope  $Q$  put at height 1*.

We are interested in the deformations of the pair  $(X, \partial X)$ .

**Remark 5.2** (Tangent space to deformations of  $X$ ). Let  $\sigma$  be a Gorenstein cone of dimension  $n$  and let  $X$  be the corresponding Gorenstein toric singularity. Let  $v_0 \in M$  be as in Definition 5.1. Altmann [Alt94] has computed the tangent space to the deformation functor of  $X$ :  $T_X^1 = \text{Ext}_{\mathcal{O}_X}^1(\Omega_X, \mathcal{O}_X)$ . Notice that this  $\mathbb{C}$ -vector space is  $M$ -graded. We denote by  $T_X^1(v)$  the graded piece of  $T_X^1$  with degree  $v \in M$ . We give the formulae for dimension 2 and 3 only.

If  $n = 2$ , then  $X$  is a Du Val singularity of type  $A_{m-1}$ , for some  $m \in \mathbb{N}^+$ , and

$$T_X^1(v) = \begin{cases} \mathbb{C} & \text{if } v = lv_0 \text{ for } 2 \leq l \leq m, \\ 0 & \text{otherwise.} \end{cases}$$

If  $n = 3$ , then  $\sigma$  is the cone over a lattice polygon  $Q$  put at height 1. Let  $E_1, \dots, E_k$  be the edges of  $Q$  and let  $\ell_1, \dots, \ell_k \in \mathbb{N}^+$  be their lattice lengths. For each  $i = 1, \dots, k$ , let  $z_i \in \sigma^\vee \cap M$  be the primitive generator of the ray of  $\sigma^\vee$  which is dual to the edge  $E_i$ . Notice that  $X$  has an isolated singularity if and only if  $\ell_1 = \dots = \ell_k = 1$ . Altmann [Alt00, Theorem 4.4] proves the following:  $T_X^1(v)$  is non-zero only in the following cases

- (i)  $v = v_0$  with  $\dim_{\mathbb{C}} T_X^1(v) = k - 3$ ;
- (ii)  $v = qv_0$ , for  $q \geq 2$ , with  $\dim_{\mathbb{C}} T_X^1(v) = \max\{0, \#\{i \mid q \leq \ell_i\} - 2\}$ ;
- (iii)  $v = qv_0 + pz_i \notin -\text{int}(\sigma^\vee)$ ,  $2 \leq q \leq \ell_i, p \in \mathbb{Z}$ , with  $\dim_{\mathbb{C}} T_X^1(v) = 1$ ;

additional degrees exist only in the following two (overlapping) exceptional cases:

- (iv)  $Q$  contains a pair of parallel edges  $E_{i_1}, E_{i_2}$ , both longer than every other edge, then  $\dim_{\mathbb{C}} T_X^1(qv_0) = 1$  if  $\max\{\ell_i \mid i \neq i_1, i_2\} < q \leq \min\{\ell_{i_1}, \ell_{i_2}\}$ ;
- (v)  $Q$  contains a pair of parallel edges  $E_{i_1}, E_{i_2}$  with distance  $\delta = \langle z_{i_1}, E_{i_2} \rangle = \langle z_{i_2}, E_{i_1} \rangle$ , then  $\dim_{\mathbb{C}} T_X^1(qv_0 - pz_{i_1}) = 1$  if  $\ell_{i_2} > \delta \geq \max\{\ell_i \mid i \neq i_1, i_2\}$ ,  $1 \leq q \leq \ell_j$  and  $1 \leq p \leq (\ell_k - q)/\delta$ .

The cases (i), (ii), (iv), and (v) yield at most finitely many degrees in  $T_X^1$ . Type (iii) consists of  $\ell_i - 1$  infinite series for any  $i = 1, \dots, k$ . Therefore  $T_X^1$  has finite dimension (and consequently the miniversal deformation of  $X$  exists) if and only if  $X$  has an isolated singularity.

**Remark 5.3.** If  $\sigma$  is a Gorenstein cone and  $X = \text{TV}_{\mathbb{C}}(\sigma)$  is an *isolated singularity*, then Altmann [Alt97] has given an explicit construction for the miniversal deformation of  $X$ .

We know very little about deformations of the toric Gorenstein affine pair  $(X, \partial X)$  if the dimension is greater than 2. Even if  $X$  is smooth, the tangent space is not finite-dimensional: for instance one can consider deformations of  $(\mathbb{A}^3, \{xyz = 0\})$  with an arbitrarily large number of parameters, e.g.  $(\mathbb{A}^3, \{xyz = f(z)\})$  where  $f(z)$  is an arbitrary polynomial in  $z$ . Moreover, at present, a combinatorial description of the tangent space of  $\mathcal{D}ef_{(X, \partial X)}$  is not known.

In dimension 3, using Theorem 3.10, we have found extra degrees for deformations of the pair  $(X, \partial X)$  that do not appear in  $T_X^1$ , i.e. degrees that deform the pair but keep  $X$  fixed. Examples of these degrees are very similar to type (iii) in Remark 5.2:  $v = v_0 + pz_i \notin -\text{int}(\sigma^\vee)$ ,  $p \in \mathbb{N}^+$ . We will use these degrees, together with those in Remark 5.2 to populate the slabs of the polyhedral decomposition we are going to construct below.

## 5.2. The surface case

In this section we construct the initial setup of the Gross–Siebert program in the case of a Gorenstein toric singularity of dimension 2. This section is heavily inspired by [GHK, §6] and [Pri].

### 5.2.1. Equations and deformations

If  $\sigma$  is a Gorenstein cone of dimension 2, then it is the cone over a segment of length  $m$ , for some  $m \in \mathbb{N}^+$ . Up to change of lattice basis, we can assume  $N = \mathbb{Z}^2$  and

$$\sigma = \text{cone} \left\langle \begin{pmatrix} 0 \\ 1 \end{pmatrix}, \begin{pmatrix} m \\ 1 \end{pmatrix} \right\rangle \subseteq N_{\mathbb{R}}.$$

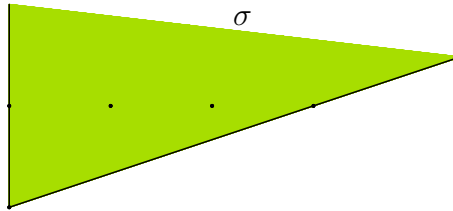

The dual cone is  $\sigma^\vee = \text{cone} \langle (1, 0), (-1, m) \rangle \subseteq M_{\mathbb{R}}$ . The element  $v_0 \in M$  defined in Definition 5.1 is  $v_0 = (0, -1)$ . Call  $x = (1, 0)$ ,  $y = (-1, m)$ ,  $z = (0, 1)$ .

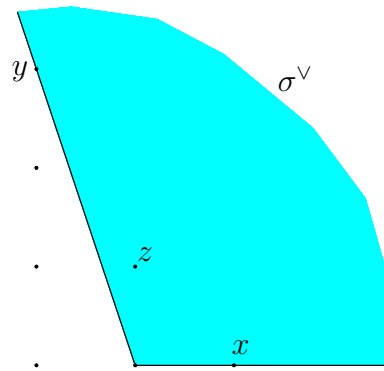

We see that  $\{x, y, z\}$  is a set of generators of the monoid  $\sigma^\vee \cap M$ . We obtain that  $X = \text{TV}_{\mathbb{C}}(\sigma) = \text{Spec } \mathbb{C}[\sigma^\vee \cap M]$  is the  $A_{m-1}$ -singularity, i.e. the quotient  $\frac{1}{m}(1, m-1)$  or equivalently

$$X = \text{Spec } \mathbb{C}[x, y, z]/(xy - z^m).$$

The toric boundary is

$$\partial X = \text{Spec } \mathbb{C}[x, y, z]/(xy, z).$$

As in §4.1 or Remark 5.2, the tangent space of the deformation functor of  $X$  has dimension  $m - 1$ . One can show that the miniversal deformation of  $X$  is

$$\text{Spf } \mathbb{C}[x, y, z][[s_0, \dots, s_{m-2}]]/(xy - (z^m + s_{m-2}z^{m-2} + \dots + s_0))$$

over  $\mathbb{C}[[s_0, \dots, s_{m-2}]]$ . By [GHK, §6.4], the miniversal deformation of the pair  $(X, \partial X)$



is  $\mathfrak{B} \hookrightarrow \mathfrak{X} \rightarrow \mathrm{Spf} \mathbb{C}[[s_0, \dots, s_{m-1}]]$ , where

$$\begin{aligned} \mathfrak{X} &= \mathrm{Spf} \mathbb{C}[x, y, z][[s_0, \dots, s_{m-1}]] / (xy - (z^m + s_{m-1}z^{m-1} + \dots + s_0)), \\ \mathfrak{B} &= \mathrm{Spf} \mathbb{C}[x, y, z][[s_0, \dots, s_{m-1}]] / (xy - (z^m + s_{m-1}z^{m-1} + \dots + s_0), z). \end{aligned}$$

### 5.2.2. The polyhedral subdivision of $v_0 + \sigma^\vee$

Let  $\sigma \subseteq N_{\mathbb{R}}$ ,  $\sigma^\vee \subseteq M_{\mathbb{R}}$  and  $v_0 \in M$  be as in §5.2.1. For brevity we set  $v := v_0$ . We call  $u$  the origin of  $M$ . We consider the polyhedral decomposition  $\mathcal{P}$  of the 2-dimensional polyhedron  $v + \sigma^\vee$  given by the following three 2-dimensional polyhedra:

- $\sigma^\vee = \mathrm{cone} \langle x, y \rangle$ ,
- $\mathrm{conv} \langle u, v \rangle + \mathrm{cone} \langle x \rangle$ ,
- $\mathrm{conv} \langle u, v \rangle + \mathrm{cone} \langle y \rangle$ .

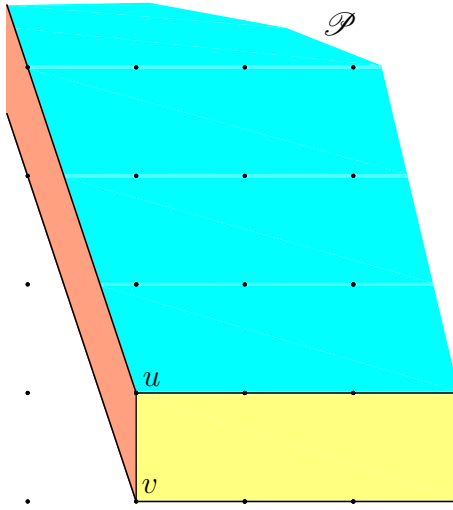

The Mumford degeneration (cf. [Gro11, §6.2.1]) of  $X$  associated to the polyhedral complex  $\mathcal{P}$  is

$$\mathrm{Proj} \mathbb{C}[t, x, y, z, u, v] / (xy - z^m, zv - tu) \longrightarrow \mathrm{Spec} \mathbb{C}[t] = \mathbb{A}^1,$$

where  $\deg t = \deg x = \deg y = \deg z = 0$  and  $\deg u = \deg v = 1$ . Equivalently, we consider the closed subscheme of  $\mathbb{P}_{[u:v]}^1 \times \mathbb{A}_{x,y,z}^3 \times \mathbb{A}_t^1$  defined by the equations

$$\begin{cases} xy = z^m \\ zv = tu \end{cases}$$

The central fibre of this family is given by the equations  $xy = z^m$  and  $zv = 0$ . So it is the union of 3 irreducible components which are isomorphic to  $A_{m-1}$ ,  $\mathbb{A}^1 \times \mathbb{P}^1$  and  $\mathbb{A}^1 \times \mathbb{P}^1$ . These components can be seen from the polyhedral complex  $\mathcal{P}$ : the maximal polyhedral cells of  $\mathcal{P}$  are the moment polyhedra of these 3 components.

Every fibre over  $t \neq 0$  is isomorphic to  $X$ .

The boundary divisor is given by adding the extra equation  $u = 0$ .

### 5.2.3. The initial scattering diagram

Over the polyhedral complex  $\mathcal{P}$  we introduce some singularities specifying a structure of affine manifold with singularities on  $v + \sigma^\vee$ . Specifically, we put  $m$  focus-focus singularities on the segment  $\text{conv}\langle u, v \rangle$  in order that the boundary becomes flat. This is a standard procedure in the Gross–Siebert program and we refer the reader to [GS11b], [Gro11], and [Pri].

After specifying a structure of affine manifold with singularities on  $\mathcal{P}$  we need to put *slab functions*. By definition, a *slab* is an interior cell of  $\mathcal{P}$  of codimension 1. A slab  $\mathfrak{s}$  corresponds to a codimension 1 stratum  $X_{\mathfrak{s}}$  of the central fibre  $X_0$  of the Mumford degeneration corresponding to the polyhedral complex  $\mathcal{P}$ . A slab function on the slab  $\mathfrak{s}$  is then a section of a line bundle over  $X_{\mathfrak{s}}$  which is specified by the affine manifold structure. The datum of a polyhedral complex  $\mathcal{P}$  together with a structure of affine manifold with singularities and with slab functions is called an *initial scattering diagram*.

In our case, there is only one compact slab: namely  $\text{conv}\langle u, v \rangle$ . It corresponds to the toric stratum  $\mathbb{P}^1 = \text{Proj } \mathbb{C}[u, v]$  of  $X_0 = \text{Proj } \mathbb{C}[x, y, z, u, v]/(xy - z^m, zv)$ . The line bundle in this case is  $\mathcal{O}_{\mathbb{P}^1}(m)$  as there are  $m$  focus-focus singularities on  $\text{conv}\langle u, v \rangle$ . The slab function we consider is

$$u^m + s_{m-1}u^{m-1}v + \cdots + s_0v^m \in H^0(\mathbb{P}_{[u,v]}^1, \mathcal{O}_{\mathbb{P}^1}(m)),$$

where  $s_0, \dots, s_{m-1}$  are parameters. On the other two slabs, namely  $u + \text{conv}\langle x \rangle$  and  $u + \text{conv}\langle y \rangle$ , we put the slab function 1.

Morally, the slab functions specify the direction in which one deforms the central fibre  $X_0$  and can be interpreted as a logarithmic structure on  $X_0$  (see [GS06, GS10]). What has been described so far is the starting point of the Kontsevich–Soibelman–Gross–Siebert reconstruction algorithm [GS11a]: from an initial scattering diagram, under some assumptions, one produces a formal flat deformation of  $X_0$  in such a way the slab functions constitute the first approximation for gluing the various torus charts of the fibres of this family (see [GS11a, Pri]).

The Kontsevich–Soibelman–Gross–Siebert algorithm applied to our initial scattering diagram produces the formal family  $\mathfrak{X} \rightarrow \mathrm{Spf} \mathbb{C}[s_0, \dots, s_{m-1}][[t]]$  which is defined by the equations

$$\begin{cases} xy = z^m + ts_{m-1}z^{m-1} + \dots + t^m s_0 \\ zv = tu \end{cases}$$

inside  $\mathbb{P}_{[u,v]}^1 \times \mathbb{A}_{x,y,z}^3$ . The boundary is given by  $\mathfrak{B} = \mathfrak{X} \cap \{u = 0\}$ .

This family is algebraizable with respect to  $t$ . By setting  $t = 1$ , we get the miniversal deformation of the pair  $(X, \partial X)$  described in §5.2.1.

### 5.3. The three-dimensional case

In this section we fix a Gorenstein cone  $\sigma$  in a lattice  $N$  of rank 3. So  $\sigma$  is the cone over a lattice polygon  $Q$  put at height 1, as in §5.1. Let  $v_0 \in M$  be the element defined in Definition 5.1.

In §5.3.1 we construct a polyhedral subdivision of  $v_0 + \sigma^\vee$ , depending on the choice of numbers  $a_1, \dots, a_k \in \mathbb{N}$ . In §5.3.2, starting from an admissible decomposition of  $Q$  (see Definition 5.5), we will describe a collection of slab functions on the polyhedral subdivision of §5.3.1: this is an initial scattering diagram. We expect that there is a more general version of the Kontsevich–Soibelman–Gross–Siebert algorithm for our initial scattering diagram: this should lead to a conjecture discussed in §5.3.3.

#### 5.3.1. The polyhedral subdivision of $v_0 + \sigma^\vee$

Let  $N$  be a lattice of rank 3, let  $\sigma$  be Gorenstein cone inside  $N$ , and let  $\sigma^\vee \subseteq M_{\mathbb{R}}$  be its dual. Let  $Q$  be the corresponding lattice polygon. Let  $v_0 \in M$  be as in Definition 5.1. We denote by  $u$  the origin on  $M$ .

Let  $E_1, \dots, E_k$  be the edges of  $Q$ , cyclically ordered. For each  $i = 1, \dots, k$ , let  $z_i \in \sigma^\vee \cap M$  be the primitive generator of the ray of  $\sigma^\vee$  which is dual to the edge  $E_i$ . We consider the indices  $i$  modulo  $k$ , i.e.  $z_{k+1} = z_1$ .

Choose  $\mathbf{a} = (a_1, \dots, a_k) \in \mathbb{N}^k$ . Depending on this choice, we define a polyhedral subdivision of  $v_0 + \sigma^\vee$ . For brevity we define  $v_i := v_0 + a_i z_i \in M$  for each  $i$ .

Firstly we treat the case when  $\mathbf{a} = \mathbf{0}$  is the zero vector. Then  $\mathcal{P}_0$  is the polyhedral complex with support  $v_0 + \sigma^\vee$  and with  $k + 1$  cells of dimension 3:

- $\sigma^\vee = \{u\} + \mathrm{cone} \langle z_1, \dots, z_k \rangle$ ,
- $\mathrm{conv} \langle u, v_0 \rangle + \mathrm{cone} \langle z_i, z_{i+1} \rangle$ , as  $i = 1, \dots, k$ .

For a general  $\mathbf{a} \in \mathbb{N}^k$ , the polyhedral complex  $\mathcal{P}_{\mathbf{a}}$  is finer than  $\mathcal{P}_{\mathbf{0}}$  and its 3-dimensional cells are as follows:

- $\sigma^{\vee} = \{u\} + \text{cone} \langle z_1, \dots, z_k \rangle$ ;
- for each  $i = 1, \dots, k$ , we have to decide how to subdivide the cell  $\text{conv} \langle u, v_0 \rangle + \text{cone} \langle z_i, z_{i+1} \rangle$ ; we have the following four cases (these are also shown in Figure 5.1):
  - (i) if  $a_i = a_{i+1} = 0$ , then we take the whole cell  $\text{conv} \langle u, v_0 \rangle + \text{cone} \langle z_i, z_{i+1} \rangle$ ,
  - (ii) if  $a_i = 0$  and  $a_{i+1} > 0$ , then we take  $\text{conv} \langle u, v_0, v_{i+1} \rangle + \text{cone} \langle z_i \rangle$  and  $\text{conv} \langle u, v_{i+1} \rangle + \text{cone} \langle z_i, z_{i+1} \rangle$ ,
  - (iii) if  $a_i > 0$  and  $a_{i+1} = 0$ , then we take  $\text{conv} \langle u, v_0, v_i \rangle + \text{cone} \langle z_{i+1} \rangle$  and  $\text{conv} \langle u, v_i \rangle + \text{cone} \langle z_i, z_{i+1} \rangle$ ,
  - (iv) if  $a_i > 0$  and  $a_{i+1} > 0$ , then we take  $\text{conv} \langle u, v_i, v_{i+1} \rangle + \text{cone} \langle z_i, z_{i+1} \rangle$  and  $\text{conv} \langle u, v_0, v_i, v_{i+1} \rangle$ .

In the terminology of the Gross–Siebert program [GS11a], a *slab* is an interior codimension 1 polyhedral cell. We only consider the ones which are bounded: these are  $\text{conv} \langle u, v_0, v_i \rangle$ , for any  $i$  such that  $a_i > 0$ . This triangle is an  $A_{a_i-1}$ -triangle (see Definition 5.4): it is the moment polytope of  $(\mathbb{P}(1, 1, a_i), \mathcal{O}(a_i))$ , i.e. the convex hull of the monomial basis of  $H^0(\mathbb{P}(1, 1, a_i), \mathcal{O}(a_i))$ .

In §5.3.2, on these slabs we will put some *slab functions*, i.e. some sections of certain line bundles over  $\mathbb{P}(1, 1, a_i)$ .

### 5.3.2. The initial scattering diagram

Before describing the slab functions of our initial scattering diagram on  $\mathcal{P}_{\mathbf{a}}$ , we need a couple of definitions.

**Definition 5.4.** If  $m \in \mathbb{N}$ , an  $A_m$ -triangle is any lattice polygon which is equivalent, up to affine transformations, to the triangle  $\text{conv} \langle (0, 0), (0, 1), (m + 1, 1) \rangle$  inside  $\mathbb{Z}^2$ . An  $A_{-1}$ -triangle is a lattice segment of lattice length 1.

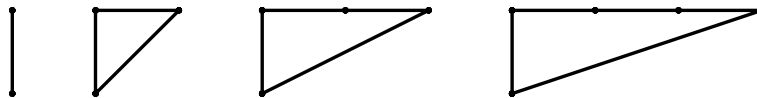

For  $m \in \mathbb{N}$ , a triangle in a lattice of rank 2 is an  $A_m$ -triangle if and only if it does not contain any interior point and the lattice lengths of its edges are 1, 1, and  $m + 1$ . An  $A_m$ -triangle is the moment polytope of  $(\mathbb{P}(1, 1, m + 1), \mathcal{O}(m + 1))$ .

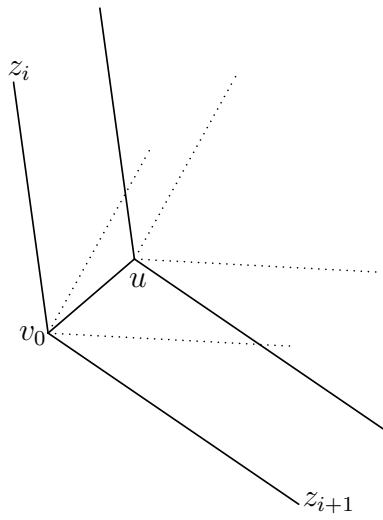

(i)  $a_i = a_{i+1} = 0$

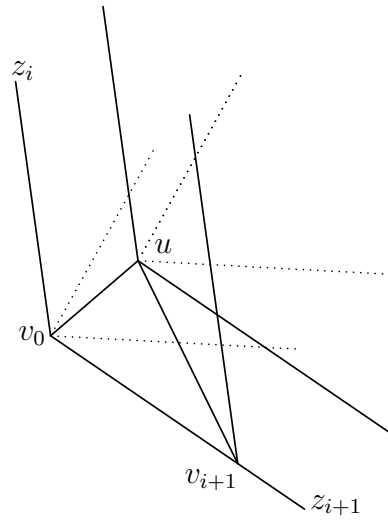

(a) (ii)  $a_i = 0$  and  $a_{i+1} > 0$

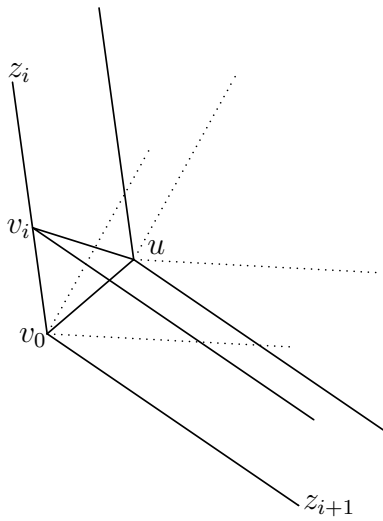

(iii)  $a_i > 0$  and  $a_{i+1} = 0$

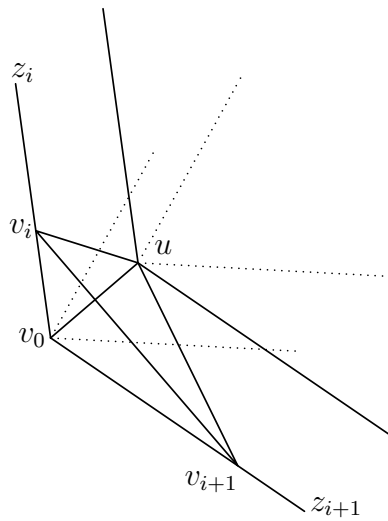

(iv)  $a_i > 0$  and  $a_{i+1} > 0$

Figure 5.1: the four possible polyhedral subdivisions of  $\text{conv}\langle u, v_0 \rangle + \text{cone}\langle z_i, z_{i+1} \rangle$  discussed in §5.3.1

**Definition 5.5.** Let  $Q$  be a lattice polygon. A Minkowski decomposition  $Q = Q_1 + \cdots + Q_r$  is called *admissible* if each  $Q_j$  is an  $A_{m_j}$ -triangle for some  $m_j \in \mathbb{Z}$ ,  $m_j \geq -1$ .

**Remark 5.6.** A polygon need not have any admissible decomposition: e.g. the triangle  $\text{conv}\langle(-1, -1), (2, -1), (-1, 1)\rangle$  in  $\mathbb{Z}^2$ .

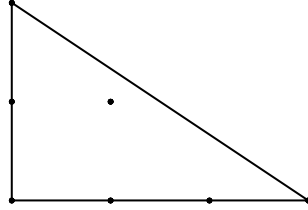

We are now ready to describe the initial scattering diagram. Let  $\sigma \subseteq N_{\mathbb{R}}$ ,  $\sigma^{\vee} \subseteq M_{\mathbb{R}}$ , and  $v_0 \in M$  be as above. Fix  $\mathbf{a} \in \mathbb{N}^k$  and consider the polyhedral complex  $\mathcal{P}_{\mathbf{a}}$ , with support  $v_0 + \sigma^{\vee}$ , described in §5.3.1. The initial scattering diagram, i.e. the collection of slab functions, depends on the choice of an admissible decomposition of  $Q$ , which we now fix  $Q = Q_1 + \cdots + Q_r$ .

Let  $E_1, \dots, E_k$  be the edges of  $Q$ , cyclically ordered, and let  $\ell_1, \dots, \ell_k \in \mathbb{N}^+$  be their lattice lengths. For any  $i = 1, \dots, k$  and  $j = 1, \dots, r$ , let  $\ell_{ij} \in \mathbb{N}$  be the number of times with which the primitive generator of the edge  $E_i$  (which points toward  $E_{i+1}$ ) appears as an edge of  $Q_j$ . In other words,  $\ell_{ij}$  is the lattice length of the edge (if it exists) of  $Q_j$  which is parallel (and with the same orientation) of  $E_i$ . It is clear that  $\sum_{j=1}^r \ell_{ij} = \ell_i$  for all  $i$ . Here we are implicitly assuming that the  $A_{-1}$ -triangle, i.e. the unitary segment, has two opposite edges of length 1.

We choose parameters  $s_1, \dots, s_r$ . We now describe the slab functions. Fix  $1 \leq i \leq k$ .

If  $a_i = 0$ , then the slab function on  $\text{conv}\langle u, v_0 \rangle + \text{cone}\langle z_i \rangle$  is

$$\prod_{j=1}^r (u + s_j v_0)^{\ell_{ij}} \in H^0(\mathbb{P}_{[u:v_0]}^1 \times \mathbb{A}_{z_i}^1, \mathcal{O}(\ell_i))$$

If  $a_i > 0$ , then the slab function on the slab  $\text{conv}\langle u, v_0, v_i \rangle$  is a section  $f_i \in H^0(\mathbb{P}(1, 1, a_i), \mathcal{O}(\ell_i a_i))$  satisfying the following *divisibility conditions*. Let  $x_0, x_i, u$  be the Cox coordinates on  $\mathbb{P}(1, 1, a_i)$  with weights 1, 1,  $a_i$ , respectively. So the integral points of  $\text{conv}\langle u, v_0, v_i \rangle$  are the monomial basis  $\{u, v_0 = x_0^{a_i}, x_0^{a_i-1} x_i, \dots, v_i = x_i^{a_i}\}$  of  $H^0(\mathbb{P}(1, 1, a_i), \mathcal{O}(a_i))$ .

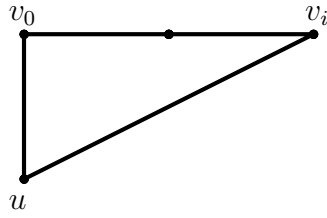

We require that the restriction of  $f_i$  to the curve  $\{x_i = 0\} \simeq \mathbb{P}(1, a_i)_{x_0, u}$  is

$$g_{i,0} := \prod_{j=1}^r (u + s_j x_0^{a_j})^{\ell_{ij}}.$$

This specifies the intersection multiplicities between the curve  $\{f_i = 0\}$  and the curve  $\{x_i = 0\}$ : there is an intersection point of multiplicity  $\ell_{ij}$ , for any  $j = 1, \dots, r$ . Informally speaking, we also require that every such point is a point with multiplicity  $\ell_{ij}$  for the curve  $\{f_i = 0\}$ . This imposes some condition on other coefficients of  $f_i$  as follows. The monomial basis of  $H^0(\mathbb{P}(1, 1, a_i), \mathcal{O}(\ell_i a_i))$  is associated to the lattice points of the  $\ell_i$ th dilation of an  $A_{a_i-1}$ -triangle: up to an affine transformation, we can assume that it is the triangle

$$T = \text{conv} \langle x_0^{\ell_i a_i} = v_0^{\ell_i} = (0, 0), u^{\ell_i} = (0, \ell_i), x_i^{\ell_i a_i} = v_i^{\ell_i} = (\ell_i a_i, 0) \rangle \subseteq \mathbb{R}^2.$$

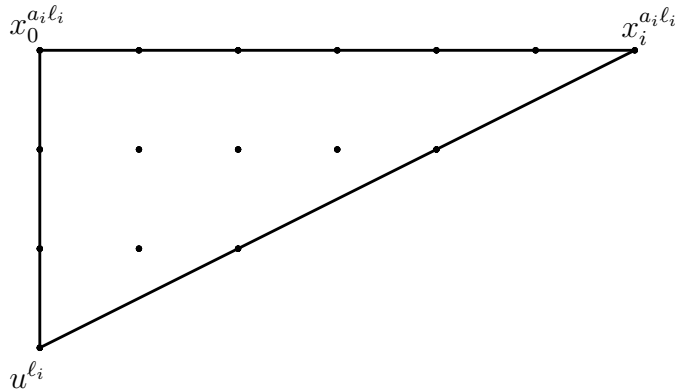

The coefficients of  $f_i$  live over the lattice points of the triangle  $T$ . So far we have specified the coefficients on the leftmost vertical segment  $\text{conv} \langle (0, 0), (0, \ell_i) \rangle \subseteq T$ , i.e. the coefficients of the monomials  $x_0^{\ell_i a_i} = v_0^{\ell_i}, x_0^{\ell_i a_i - a_i} u, \dots, u^{\ell_i}$ . For any  $1 \leq h < \ell_i$  we require some conditions on the coefficients on the vertical segment  $(\{h\} \times \mathbb{R}) \cap T$  by insisting that the polynomial supported on this vertical segment is divisible by

$$g_{i,h} := \prod_{j=1}^r (u + s_j x_0^{a_j})^{(\ell_{ij} - h)^+}.$$

Here, for a number  $a \in \mathbb{Z}$ , we use the notation  $a^+ := \max\{0, a\}$ .

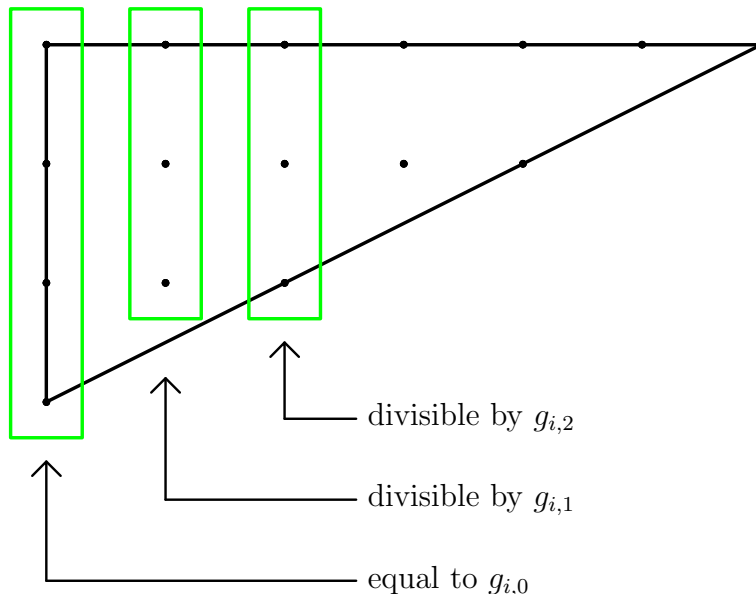

To sum up, we consider the parameters  $s_1, \dots, s_r$ , one for each Minkowski summand of  $Q$  in the fixed admissible decomposition, and then we take the most general possible slab functions, provided that we respect the divisibility conditions described above. This means that we introduce extra parameters which appear as some coefficients of slab functions, whereas some coefficients close to the segment  $\text{conv}\langle u, v_0 \rangle$  are determined by these new parameters and the parameters  $s_1, \dots, s_r$ .

The collection of these slab functions is our initial scattering diagram  $\mathfrak{D}_{\text{in}}$  on the polyhedral complex  $\mathcal{P}_{\mathbf{a}}$ . We give some examples in §5.4.

### 5.3.3. A conjecture

Starting from a scattering diagram  $\mathfrak{D}_{\text{in}}$  satisfying some hypothesis, the Kontsevich–Soibelman–Gross–Siebert algorithm [GS11a] produces a consistent scattering diagram  $\text{Scatter}(\mathfrak{D}_{\text{in}})$  and consequently an order by order deformation of the central fibre, which is the union of toric varieties associated to the chosen polyhedral complex.

Unfortunately our polyhedral complex (§5.3.1) and slab functions (§5.3.2) do not satisfy the restrictive conditions of [GS11a]. Paul Hacking has taken the slab functions we define in §5.3.2 and verified that an appropriate generalisation of the Kontsevich–Soibelman–Gross–Siebert algorithm exists in some cases. Then we expect that, starting from the choice of an admissible decomposition  $Q = Q_1 + \dots + Q_r$  and the choice of  $\mathbf{a} \in \mathbb{N}^k$ , it is possible to construct a formal deformation of the degenerate toric variety associated to the polyhedral complex  $\mathcal{P}_{\mathbf{a}}$ ; possibly this deformation is algebraizable and it is possible to set all degeneration parameters equal to 1, in order to construct a deformation of the pair  $(X, \partial X)$ . For  $a_1, \dots, a_k \rightarrow \infty$



we should get a formal deformation of  $(X, \partial X)$  over an ind-scheme. This should be an irreducible component of  $\mathcal{D}ef_{(X, \partial X)}$ .

We conjecture the following:

**Conjecture 5.7.** *The procedure described above gives an injection from the set of admissible decompositions of  $Q$  to the set of irreducible components of  $\mathcal{D}ef_{(X, \partial X)}$ .*

**Remark 5.8.** According to the general philosophy of Intrinsic Mirror Symmetry [GS], it should be possible to recover this deformation/degeneration family of  $X$  from some curve count on the mirror variety. More specifically, we expect that there should be a  $T_M$ -toric<sup>1</sup> variety  $\bar{Y}_{\mathbf{a}}$  of dimension 3 and a non-toric blow-up  $Y_{\mathbf{a}} \rightarrow \bar{Y}_{\mathbf{a}}$  such that the coordinate ring of the deformation/degeneration family of  $X$  is the ring of theta functions (see [GHK15, GHKS]) of  $\bar{Y}_{\mathbf{a}}$ .

## 5.4. Two examples

In this section we give two examples of the constructions described in §5.3.1 and §5.3.2.

### 5.4.1. The affine space of dimension 3

Let us consider the affine 3-dimensional space  $X = \text{Spec } \mathbb{C}[x, y, z] = \mathbb{A}^3$  and its toric boundary  $\partial X = \text{Spec } \mathbb{C}[x, y, z]/(xyz)$ . The deformations of  $X$  are clearly trivial, but the deformations of the pair  $(X, \partial X)$  are not. The miniversal deformation of  $(X, \partial X)$  is given by

$$(\mathbb{A}^3, \{xyz + s + x\alpha(x) + y\beta(y) + z\gamma(z) = 0\}),$$

where  $\alpha, \beta$  and  $\gamma$  are polynomials in one variable and  $s$  is a constant. The parameter space of this deformation is an infinite-dimensional ind-scheme. Following [Ran89, CFGK17b, CFGK17a], the tangent space to the deformations of the pair  $(X, \partial X)$  is

$$T_{(X, \partial X)}\mathcal{D}ef = \text{Ext}_{\mathcal{O}_{\partial X}}^1(\Omega_{\partial X}^1, \mathcal{O}_{\partial X}) = H^0(\mathcal{O}_{\text{Sing}(\partial X)}) = \frac{\mathbb{C}[x, y, z]}{(xy, xz, yz)}.$$

Another way to prove this is to notice that, since  $X$  has only trivial deformations,  $T_{(X, \partial X)}\mathcal{D}ef$  is the tangent space of the Hilbert functor of  $\partial X \hookrightarrow X$  modulo the

---

<sup>1</sup>The toric variety  $X$  contains the torus  $T_N = \text{Spec } \mathbb{C}[M]$ , whereas the variety  $\bar{Y}_{\mathbf{a}}$  contains the dual torus  $T_M = \text{Spec } \mathbb{C}[N]$ .

action of the infinitesimal automorphisms of  $X$ ; in other words

$$\begin{aligned} T_{(X,\partial X)}\mathcal{D}ef &= \operatorname{coker} \left( H^0(T_X) \rightarrow H^0(N_{\partial X/X}) \right) \\ &= \operatorname{coker} \left( H^0(T_X|_{\partial X}) \rightarrow H^0(N_{\partial X/X}) \right) \\ &= \operatorname{coker} \left( \mathcal{O}_{\partial X}^{\oplus 3} \xrightarrow{(yz, xz, xy)} \mathcal{O}_{\partial X} \right). \end{aligned}$$

The variety  $X$  is associated to the standard octant  $\sigma$  in  $N = \mathbb{Z}^3$ . In this case the polygon  $Q$  is an  $A_0$ -triangle and we consider its unique admissible decomposition. The dual cone  $\sigma^\vee \subseteq M_{\mathbb{R}}$  is the standard octant generated by  $x = (1, 0, 0)$ ,  $y = (0, 1, 0)$  and  $z = (0, 0, 1)$ . We have  $u = (0, 0, 0)$  and  $v_0 = (-1, -1, -1)$ . We discuss some cases for  $\mathbf{a} \in \mathbb{N}^3$  below.

### The case $\mathbf{a} = 0$

The polyhedral complex  $\mathcal{P}_0$  is depicted in Figure 5.2. We have also inserted the

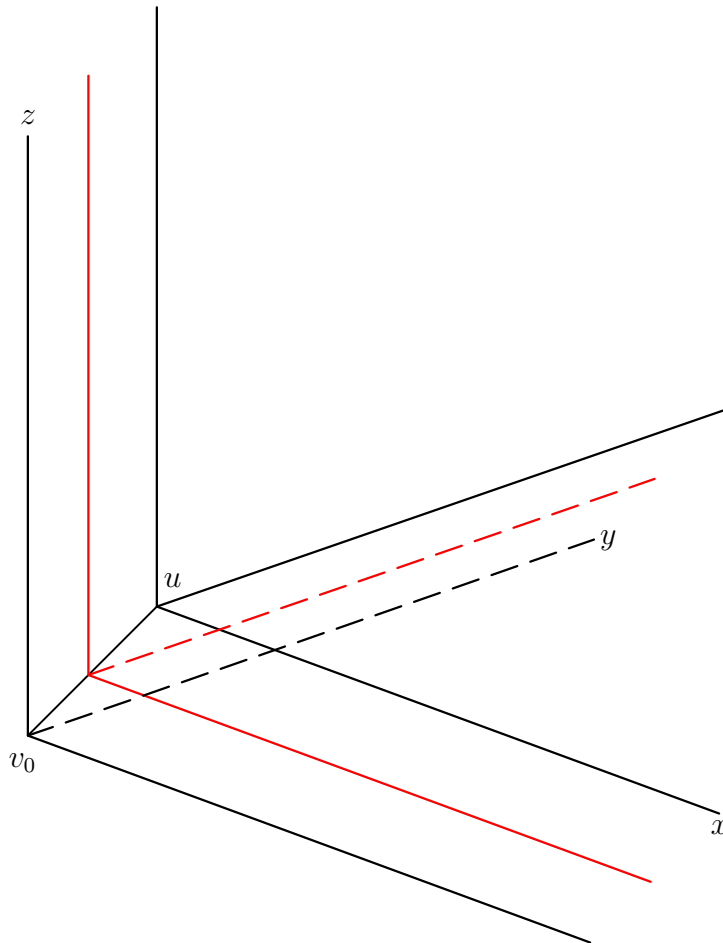

Figure 5.2: the polyhedral complex  $\mathcal{P}_0$  for  $\mathbb{A}^3$ .

singular set of an affine manifold structure on  $\mathcal{P}_0$ , drawn in red. This affine manifold structure makes the boundary flat. There are the four 3-dimensional polyhedra:  $\sigma = u + \text{cone} \langle x, y, z \rangle$ ,  $\text{conv} \langle v_0, u \rangle + \text{cone} \langle x, y \rangle$ ,  $\text{conv} \langle v_0, u \rangle + \text{cone} \langle x, z \rangle$ ,  $\text{conv} \langle v_0, u \rangle + \text{cone} \langle y, z \rangle$ .

The central fibre of the Mumford degeneration has four irreducible components and is described by the equation  $v_0xyz = 0$  inside  $\mathbb{P}_{u,v_0}^1 \times \mathbb{A}_{x,y,z}^3$ . The Mumford degeneration is given by the equation  $v_0xyz = tu$ , where  $t$  is the degeneration parameter.

There are six slabs. On each of these we consider the slab function as follows:

- $u + \text{cone} \langle x, y \rangle$ : the slab function is 1,
- $u + \text{cone} \langle x, y \rangle$ : the slab function is 1,
- $u + \text{cone} \langle x, y \rangle$ : the slab function is 1,
- $\text{conv} \langle v_0, u \rangle + \text{cone} \langle x \rangle$ : the slab function is  $u + sv_0$ ,
- $\text{conv} \langle v_0, u \rangle + \text{cone} \langle y \rangle$ : the slab function is  $u + sv_0$ ,
- $\text{conv} \langle v_0, u \rangle + \text{cone} \langle z \rangle$ : the slab function is  $u + sv_0$ .

In this case we are in the hypotheses of [GS11a]. The induced deformation is

$$\begin{aligned} \mathfrak{X} &= \{v_0xyz = t(u + sv_0)\} \subseteq \mathbb{P}_{u,v_0}^1 \times \mathbb{A}_{x,y,z}^3 \times \mathbb{A}_{t,s}^2 \\ \mathfrak{B} &= \mathfrak{X} \cap \{u = 0\}. \end{aligned}$$

By setting  $t = 1$  we get the deformation  $(\mathbb{A}^3, \{xyz = s\})$  over  $\mathbb{A}_s^1$ .

### The case $\mathbf{a} = (0, 0, 1)$

For  $\mathbf{a} = (0, 0, 1)$  we consider  $v_3 = v_0 + z = (-1, -1, 0)$ . The polyhedral decomposition  $\mathcal{P}_a$  of the polyhedron  $v_0 + \sigma^\vee$  is given by the following six 3-dimensional polyhedra:  $\sigma^\vee = u + \text{cone} \langle x, y, z \rangle$ ,  $\text{conv} \langle v_0, u \rangle + \text{cone} \langle x, y \rangle$ ,  $\text{conv} \langle u, v_0, v_3 \rangle + \text{cone} \langle x \rangle$ ,  $\text{conv} \langle u, v_0, v_3 \rangle + \text{cone} \langle y \rangle$ ,  $\text{conv} \langle v_3, u \rangle + \text{cone} \langle x, z \rangle$ ,  $\text{conv} \langle v_3, u \rangle + \text{cone} \langle y, z \rangle$ . It is depicted in Figure 5.3. The central fibre of the Mumford degeneration has six irreducible components and is described by the equations  $v_0z = v_3xy = 0$  inside  $\mathbb{P}_{u,v_0,v_3}^2 \times \mathbb{A}_{x,y,z}^3$ . The Mumford degeneration is given by the equations  $v_0z - t_1v_3 = v_3xy - t_2u = 0$ , where  $t_1, t_2$  are degeneration parameters.

We consider another parameter  $\sigma_1$ . There are six slabs. The relevant slab function are as follows:

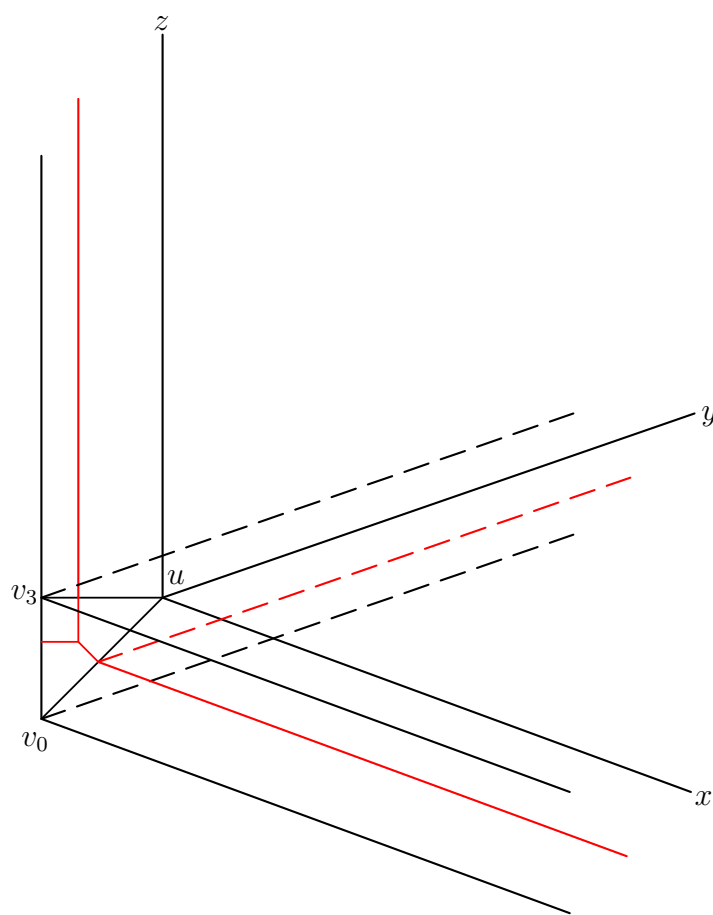

Figure 5.3: the polyhedral complex  $\mathcal{P}_{(0,0,1)}$  for  $\mathbb{A}^3$ .

- $\text{conv}\langle v_0, u \rangle + \text{cone}\langle x \rangle$ : the slab function is  $u + sv_0$ ,
- $\text{conv}\langle v_0, u \rangle + \text{cone}\langle y \rangle$ : the slab function is  $u + sv_0$ ,
- $\text{conv}\langle v_0, v_3, u \rangle$ : the slab function is  $u + sv_0 + \sigma_1 v_3$ ,
- $\text{conv}\langle v_3, u \rangle + \text{cone}\langle z \rangle$ : the slab function is  $u + \sigma_1 v_3$ .

The induced family is

$$\mathfrak{X} = \left\{ \begin{array}{l} v_0 z = t_1 v_3 \\ v_3 x y = t_2 (u + s v_0 + \sigma_1 v_3) \end{array} \right\} \subseteq \mathbb{P}_{u, v_0, v_3}^2 \times \mathbb{A}_{x, y, z}^3 \times \mathbb{A}_{t_1, t_2, s, \sigma_1}^4,$$

$$\mathfrak{B} = \mathfrak{X} \cap \{u = 0\}.$$

By setting  $t_1 = t_2 = 1$  we get the deformation  $(\mathbb{A}^3, \{xyz = s + \sigma_1 z\})$  over  $\mathbb{A}_{s, \sigma_1}^2$ .

**The case  $\mathbf{a} = (0, 0, a)$**

Consider  $a \in \mathbb{N}^+$  and  $\mathbf{a} = (0, 0, a)$ . In this case we consider the point  $v_3 = v_0 + az = (-1, -1, a - 1)$ . In Figure 5.4 there is a picture with  $a = 2$ .

The unique compact slab is  $\text{conv}\langle u, v_0, v_3 \rangle$ , which is an  $A_{a-1}$ -triangle, i.e. the moment polytope of  $(\mathbb{P}(1, 1, a), \mathcal{O}(a))$ . Let  $x_0, x_3, u$  be the Cox coordinates on  $\mathbb{P}(1, 1, a)$  with weights 1, 1,  $a$ , respectively. Then  $v_0$  and  $v_3$  are identified with  $x_0^a$  and  $x_3^a$ , respectively. We consider new parameters  $\sigma_1, \dots, \sigma_a$ . The slab function on  $\text{conv}\langle u, v_0, v_3 \rangle$  is the following section of  $\mathcal{O}(a)$  over  $\mathbb{P}(1, 1, a)$ :

$$u + s x_0^a + \sigma_1 x_0^{a-1} x_3 + \dots + \sigma_a x_3^a.$$

The deformation we get should be

$$(\mathbb{A}^3, \{xyz = s + \sigma_1 z + \dots + \sigma_a z^a\})$$

over  $\mathbb{A}_{s, \sigma_1, \dots, \sigma_a}^{a+1}$ .

### 5.4.2. The singularity $cA_1$

We consider the toric variety  $X = \text{Spec } \mathbb{C}[x, y, z, w]/(xy - w^2)$  which is associated to the cone  $\sigma \subseteq \mathbb{N}_{\mathbb{R}} = \mathbb{R}^3$  whose rays are  $(1, 1, 0)$ ,  $(-1, 1, 0)$  and  $(0, 0, 1)$ . The Hilbert basis of the dual cone  $\sigma^\vee \subseteq M_{\mathbb{R}}$  is made up of the following four vectors:  $x = (1, 1, 0)$ ,  $y = (-1, 1, 0)$ ,  $w = (0, 1, 0)$  and  $z = (0, 0, 1)$ . We have  $v_0 = (0, -1, -1)$ . The toric boundary of  $X$  is  $\partial X = X \cap \{zw = 0\} = \text{Spec } \mathbb{C}[x, y, z, w]/(xy - w^2, zw)$ .

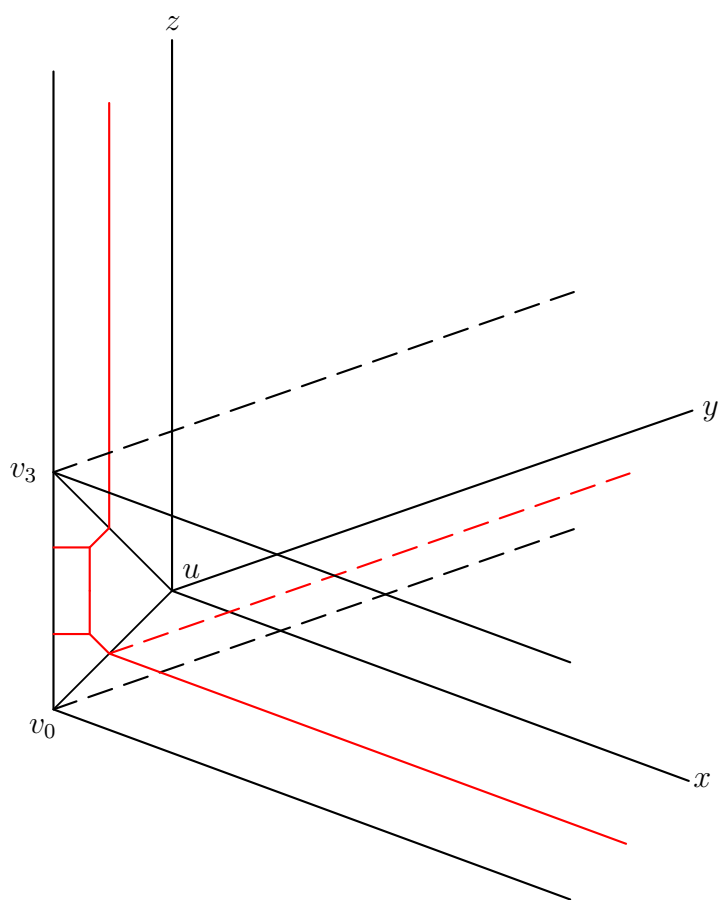

Figure 5.4: the polyhedral complex  $\mathcal{P}_{(0,0,2)}$  for  $\mathbb{A}^3$ .

The polygon  $Q$  is an  $A_1$ -triangle and we consider its unique admissible decomposition. Below we consider two cases for  $\mathbf{a} \in \mathbb{N}^3$ .

**The case  $\mathbf{a} = \mathbf{0}$**

For  $\mathbf{a} = \mathbf{0}$  we get the polyhedral decomposition  $\mathcal{P}_0$  with four 3-dimensional cells, depicted in Figure 5.5. The singular set of the affine manifold structure on  $v_0 + \sigma^\vee$  is drawn in red. On the slab  $\text{conv}\langle u, v_0 \rangle + \text{cone}\langle z \rangle$  the monodromy is double, in order to make the boundary flat: this is shown bold in the picture below. Notice that the edge of  $Q$  which is dual to  $z$  has lattice length 2.

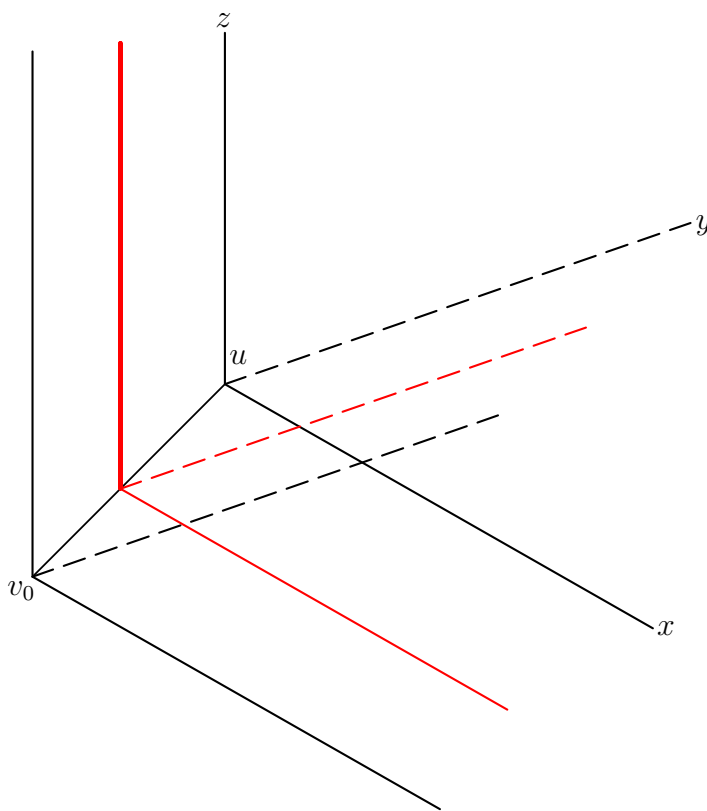

Figure 5.5: the polyhedral complex  $\mathcal{P}_0$  for  $cA_1$ .

The slab functions on  $\text{conv}\langle u, v_0 \rangle + \text{cone}\langle x \rangle$  and on  $\text{conv}\langle u, v_0 \rangle + \text{cone}\langle y \rangle$  are both  $u + sv_0$ . The slab function on  $\text{conv}\langle u, v_0 \rangle + \text{cone}\langle z \rangle$  is  $(u + sv_0)^2$ .

We expect that the family is given by the equations

$$\begin{aligned} \mathfrak{X} &= \{z w v_0 = t(u + s v_0), x y = w^2\} \\ \mathfrak{B} &= \mathfrak{X} \cap \{u = 0\} \end{aligned}$$

inside  $\mathbb{P}_{u,v_0}^1 \times \mathbb{A}_{w,x,y,z}^4 \times \mathbb{A}_{t,s_1}^2$ .

By setting  $t = 1$ , this produces the deformation

$$(\{xy = w^2\}, \{xy = w^2, zw = s\})$$

over  $\mathbb{A}_s^1$ .

**The case  $\mathbf{a} = (0, 0, 1)$**

For  $\mathbf{a} = (0, 0, 1)$  we consider  $v_3 = v_0 + z = (0, -1, 0)$ . The polyhedral complex  $\mathcal{P}_{\mathbf{a}}$  is depicted in Figure 5.6, together with the singular set of the affine manifold structure.

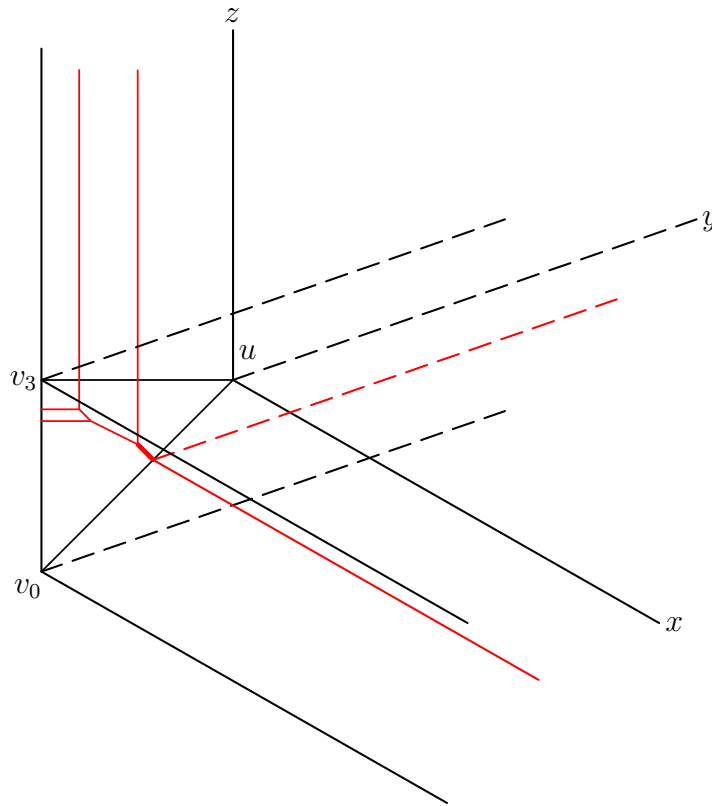

Figure 5.6: the polyhedral complex  $\mathcal{P}_{(0,0,1)}$  for  $cA_1$ .

The unique compact slab is  $\text{conv}\langle u, v_0, v_3 \rangle$ : it is the moment polytope of  $(\mathbb{P}^2, \mathcal{O}(1))$ . Since the edge of  $Q$  dual to  $z$  has length 2, the slab function on  $\text{conv}\langle u, v_0, v_3 \rangle$  is a section of  $\mathcal{O}_{\mathbb{P}^2}(2)$ . If we follow the divisibility conditions described in §5.3.2, we introduce new parameters  $\sigma_1$  and  $\sigma_2$  and we consider the slab function

$$(u + sv_0)^2 + \sigma_1 v_3(u + sv_0) + \sigma_2 v_3^2,$$

whose coefficients are depicted below.



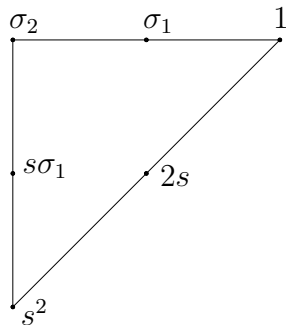

The family  $\mathfrak{X}$  should be given by the equations

$$\begin{aligned} xy &= w^2 + t\sigma_1 w + t^2\sigma_2 \\ zv_0 &= tv_3 \\ wv_3 &= t(u + sv_0) \end{aligned}$$

inside  $\mathbb{P}_{u,v_0,v_3}^2 \times \mathbb{A}_{x,y,z,w}^4 \times \mathbb{A}_{t,s,\sigma_1,\sigma_2}^4$ , and the boundary  $\mathfrak{B}$  is obtained by imposing  $u = 0$ .

By setting  $t = 1$  we get the deformation

$$(\{xy = w^2 + \sigma_1 w + \sigma_2\}, \{xy = w^2 + \sigma_1 w + \sigma_2, wz = s\})$$

inside  $\mathbb{A}_{x,y,z,w}^4$  over  $\mathbb{A}_{s,\sigma_1,\sigma_2}^3$ .



# Bibliography

- [ACC<sup>+</sup>16] M. Akhtar, T. Coates, A. Corti, L. Heuberger, A. Kasprzyk, A. Oneto, A. Petracci, T. Prince, and K. Tveiten, *Mirror symmetry and the classification of orbifold del Pezzo surfaces*, Proc. Amer. Math. Soc. **144** (2016), no. 2, 513–527.
- [ACGK12] M. Akhtar, T. Coates, S. Galkin, and A. M. Kasprzyk, *Minkowski polynomials and mutations*, SIGMA Symmetry Integrability Geom. Methods Appl. **8** (2012), Paper 094, 17.
- [AGV02] D. Abramovich, T. Graber, and A. Vistoli, *Algebraic orbifold quantum products*, Orbifolds in mathematics and physics (Madison, WI, 2001), 2002, pp. 1–24.
- [AGV08] ———, *Gromov-Witten theory of Deligne-Mumford stacks*, Amer. J. Math. **130** (2008), no. 5, 1337–1398.
- [AH06] K. Altmann and J. Hausen, *Polyhedral divisors and algebraic torus actions*, Math. Ann. **334** (2006), no. 3, 557–607.
- [AH11] D. Abramovich and B. Hassett, *Stable varieties with a twist*, Classification of algebraic varieties, 2011, pp. 1–38.
- [AHS08] K. Altmann, J. Hausen, and H. Süß, *Gluing affine torus actions via divisorial fans*, Transform. Groups **13** (2008), no. 2, 215–242.
- [AIP<sup>+</sup>12] K. Altmann, N. O. Ilten, L. Petersen, H. Süß, and R. Vollmert, *The geometry of  $T$ -varieties*, Contributions to algebraic geometry, 2012, pp. 17–69.
- [AKa] M. Akhtar and A. Kasprzyk, *Singularity content*. arXiv preprint arXiv:1401.5458.
- [AKb] K. Altmann and J. Kollár, *The dualizing sheaf on first-order deformations of toric surface singularities*. To appear in J. Reine Angew. Math., arXiv preprint arXiv:1601:07805.
- [Akh15] M. E. Akhtar, *Mutations of Laurent polynomials and lattice polytopes*, Ph.D. Thesis, 2015. Imperial College London. Available at <http://hdl.handle.net/10044/1/28115>.
- [Alt00] K. Altmann, *One parameter families containing three-dimensional toric Gorenstein singularities*, Explicit birational geometry of 3-folds, 2000, pp. 21–50.
- [Alt94] ———, *Computation of the vector space  $T^1$  for affine toric varieties*, J. Pure Appl. Algebra **95** (1994), no. 3, 239–259.
- [Alt95] ———, *Minkowski sums and homogeneous deformations of toric varieties*, Tohoku Math. J. (2) **47** (1995), no. 2, 151–184.

- [Alt97] ———, *The versal deformation of an isolated toric Gorenstein singularity*, Invent. Math. **128** (1997), no. 3, 443–479.
- [AV02] D. Abramovich and A. Vistoli, *Compactifying the space of stable maps*, J. Amer. Math. Soc. **15** (2002), no. 1, 27–75.
- [BCFK08] A. Bertram, I. Ciocan-Fontanine, and B. Kim, *Gromov-Witten invariants for abelian and nonabelian quotients*, J. Algebraic Geom. **17** (2008), no. 2, 275–294.
- [BCP97] W. Bosma, J. Cannon, and C. Playoust, *The Magma algebra system I: The user language*, Journal of Symbolic Computation **24** (1997), no. 3, 235–265.
- [BCS05] L. A. Borisov, L. Chen, and G. G. Smith, *The orbifold Chow ring of toric Deligne-Mumford stacks*, J. Amer. Math. Soc. **18** (2005), no. 1, 193–215.
- [Beh97] K. Behrend, *Gromov-Witten invariants in algebraic geometry*, Invent. Math. **127** (1997), no. 3, 601–617.
- [BF97] K. Behrend and B. Fantechi, *The intrinsic normal cone*, Invent. Math. **128** (1997), no. 1, 45–88.
- [Bir] C. Birkar, *Singularities of linear systems and boundedness of Fano varieties*. arXiv preprint arXiv:1609.05543.
- [BM96] K. Behrend and Yu. Manin, *Stacks of stable maps and Gromov-Witten invariants*, Duke Math. J. **85** (1996), no. 1, 1–60.
- [BR95] K. Behnke and O. Riemenschneider, *Quotient surface singularities and their deformations*, Singularity theory (Trieste, 1991), 1995, pp. 1–54.
- [CCGK16] T. Coates, A. Corti, S. Galkin, and A. Kasprzyk, *Quantum periods for 3-dimensional Fano manifolds*, Geom. Topol. **20** (2016), no. 1, 103–256.
- [CCG<sup>+</sup>14] T. Coates, A. Corti, S. Galkin, V. Golyshev, and A. Kasprzyk, *Mirror symmetry and Fano manifolds*, European Congress of Mathematics Kraków, 2–7 July 2012, 285–300 (2014). Available at arXiv:1212.1722.
- [CCIT09] T. Coates, A. Corti, H. Iritani, and H.-H. Tseng, *Computing genus-zero twisted Gromov-Witten invariants*, Duke Math. J. **147** (2009), no. 3, 377–438.
- [CCIT15] ———, *A mirror theorem for toric stacks*, Compos. Math. **151** (2015), no. 10, 1878–1912.
- [CCITa] ———. Personal communication, May 2015.
- [CCITb] ———, *Some applications of the mirror theorem for toric stacks*. arXiv preprint arXiv:1401.2611.
- [CFGK17a] C. Ciliberto, F. Flamini, C. Galati, and A. L. Knutsen, *Erratum to: A note on deformations of regular embeddings*, Rendiconti del Circolo Matematico di Palermo Series 2 **66** (2017), no. 1, 65–67.
- [CFGK17b] ———, *A note on deformations of regular embeddings*, Rendiconti del Circolo Matematico di Palermo Series 2 **66** (2017), no. 1, 53–63.
- [CFKS08] I. Ciocan-Fontanine, B. Kim, and C. Sabbah, *The abelian/nonabelian correspondence and Frobenius manifolds*, Invent. Math. **171** (2008), no. 2, 301–343.

- [CG07] T. Coates and A. Givental, *Quantum Riemann-Roch, Lefschetz and Serre*, Ann. of Math. (2) **165** (2007), no. 1, 15–53.
- [CGI<sup>+</sup>12] T. Coates, A. Gholampour, H. Iritani, Y. Jiang, P. Johnson, and C. Manolache, *The quantum Lefschetz hyperplane principle can fail for positive orbifold hypersurfaces*, Math. Res. Lett. **19** (2012), no. 5, 997–1005.
- [CH17] A. Corti and L. Heuberger, *Del Pezzo surfaces with  $\frac{1}{3}(1, 1)$  points*, Manuscripta Math. **153** (2017), no. 1-2, 71–118.
- [Chr91] J. A. Christophersen, *On the components and discriminant of the versal base space of cyclic quotient singularities*, Singularity theory and its applications, Part I (Coventry, 1988/1989), 1991, pp. 81–92.
- [CLS11] D. A. Cox, J. B. Little, and H. K. Schenck, *Toric varieties*, Graduate Studies in Mathematics, vol. 124, American Mathematical Society, Providence, RI, 2011.
- [Coa] T. Coates, *The quantum Lefschetz principle for vector bundles as a map between Givental cones*. arXiv preprint arXiv:1405.2893.
- [Cox95] D. A. Cox, *The homogeneous coordinate ring of a toric variety*, J. Algebraic Geom. **4** (1995), no. 1, 17–50.
- [CR02] A. Corti and M. Reid, *Weighted Grassmannians*, Algebraic geometry, 2002, pp. 141–163.
- [CR04] W. Chen and Y. Ruan, *A new cohomology theory of orbifold*, Comm. Math. Phys. **248** (2004), no. 1, 1–31.
- [FM98] B. Fantechi and M. Manetti, *Obstruction calculus for functors of Artin rings. I*, J. Algebra **202** (1998), no. 2, 541–576.
- [FMN10] B. Fantechi, E. Mann, and F. Nironi, *Smooth toric Deligne-Mumford stacks*, J. Reine Angew. Math. **648** (2010), 201–244.
- [FS96] K. G. Fischer and J. Shapiro, *Mixed matrices and binomial ideals*, J. Pure Appl. Algebra **113** (1996), no. 1, 39–54.
- [Ful93] W. Fulton, *Introduction to toric varieties*, Annals of Mathematics Studies, vol. 131, Princeton University Press, Princeton, NJ, 1993. The William H. Roever Lectures in Geometry.
- [GGI16] S. Galkin, V. Golyshev, and H. Iritani, *Gamma classes and quantum cohomology of Fano manifolds: gamma conjectures*, Duke Math. J. **165** (2016), no. 11, 2005–2077.
- [GHK15] M. Gross, P. Hacking, and S. Keel, *Mirror symmetry for log Calabi-Yau surfaces I*, Publ. Math. Inst. Hautes Études Sci. **122** (2015), 65–168.
- [GHK] ———, *Mirror symmetry for log Calabi-Yau surfaces I*. arXiv preprint arXiv:1106.4977v1.
- [GHKS] M. Gross, P. Hacking, S. Keel, and B. Siebert, *Theta functions on varieties with effective anti-canonical class*. arXiv preprint arXiv:1601.07081.

- [Giv01] A. B. Givental, *Gromov-Witten invariants and quantization of quadratic Hamiltonians*, Mosc. Math. J. **1** (2001), no. 4, 551–568, 645. Dedicated to the memory of I. G. Petrovskii on the occasion of his 100th anniversary.
- [Giv96] ———, *Equivariant Gromov-Witten invariants*, Internat. Math. Res. Notices **13** (1996), 613–663.
- [Giv98] A. Givental, *A mirror theorem for toric complete intersections*, Topological field theory, primitive forms and related topics (Kyoto, 1996), 1998, pp. 141–175.
- [Gol07] V. V. Golyshev, *Classification problems and mirror duality*, Surveys in geometry and number theory: reports on contemporary Russian mathematics, 2007, pp. 88–121.
- [Gro11] M. Gross, *Tropical geometry and mirror symmetry*, CBMS Regional Conference Series in Mathematics, vol. 114, Published for the Conference Board of the Mathematical Sciences, Washington, DC; by the American Mathematical Society, Providence, RI, 2011.
- [Gro66] A. Grothendieck, *Éléments de géométrie algébrique. IV. Étude locale des schémas et des morphismes de schémas. III*, Inst. Hautes Études Sci. Publ. Math. **28** (1966), 255.
- [GS06] M. Gross and B. Siebert, *Mirror symmetry via logarithmic degeneration data I*, J. Differential Geom. **72** (2006), no. 2, 169–338.
- [GS10] ———, *Mirror symmetry via logarithmic degeneration data, II*, J. Algebraic Geom. **19** (2010), no. 4, 679–780.
- [GS11a] ———, *From real affine geometry to complex geometry*, Ann. of Math. (2) **174** (2011), no. 3, 1301–1428.
- [GS11b] ———, *An invitation to toric degenerations*, Surveys in differential geometry. Volume XVI. Geometry of special holonomy and related topics, 2011, pp. 43–78.
- [GS] ———, *Intrinsic mirror symmetry and punctured Gromov-Witten invariants*. arXiv preprint 1609.00624.
- [GT13] A. Gholampour and H.-H. Tseng, *On computations of genus 0 two-point descendant Gromov-Witten invariants*, Michigan Math. J. **62** (2013), no. 4, 753–768.
- [GU10] S. Galkin and A. Usnich, *Mutations of potentials*, preprint IPMU (2010), 10–0100.
- [Hac04] P. Hacking, *Compact moduli of plane curves*, Duke Math. J. **124** (2004), no. 2, 213–257.
- [Har10] R. Hartshorne, *Deformation theory*, Graduate Texts in Mathematics, vol. 257, Springer, New York, 2010.
- [HMX14] C. D. Hacon, J. M<sup>c</sup>Kernan, and C. Xu, *ACC for log canonical thresholds*, Ann. of Math. (2) **180** (2014), no. 2, 523–571.
- [IF00] A. R. Iano-Fletcher, *Working with weighted complete intersections*, Explicit birational geometry of 3-folds, 2000, pp. 101–173.
- [Ill71] L. Illusie, *Complexe cotangent et déformations. I*, Lecture Notes in Mathematics, Vol. 239, Springer-Verlag, Berlin-New York, 1971.

- [Ilt11] N. O. Ilten, *Deformations of smooth toric surfaces*, Manuscripta Math. **134** (2011), no. 1-2, 123–137.
- [Ilt12] ———, *Mutations of Laurent polynomials and flat families with toric fibers*, SIGMA Symmetry Integrability Geom. Methods Appl. **8** (2012), no. 047, 7.
- [Iri11] H. Iritani, *Quantum cohomology and periods*, Ann. Inst. Fourier (Grenoble) **61** (2011), no. 7, 2909–2958.
- [Isk77] V. A. Iskovskih, *Fano threefolds. I*, Izv. Akad. Nauk SSSR Ser. Mat. **41** (1977), no. 3, 516–562, 717.
- [Isk78] ———, *Fano threefolds. II*, Izv. Akad. Nauk SSSR Ser. Mat. **42** (1978), no. 3, 506–549.
- [IV12] N. O. Ilten and R. Vollmert, *Deformations of rational  $T$ -varieties*, J. Algebraic Geom. **21** (2012), no. 3, 531–562.
- [Jia08] Y. Jiang, *The orbifold cohomology ring of simplicial toric stack bundles*, Illinois J. Math. **52** (2008), no. 2, 493–514.
- [Kim99] B. Kim, *Quantum hyperplane section theorem for homogeneous spaces*, Acta Math. **183** (1999), no. 1, 71–99.
- [KM94] M. Kontsevich and Yu. Manin, *Gromov-Witten classes, quantum cohomology, and enumerative geometry*, Comm. Math. Phys. **164** (1994), no. 3, 525–562.
- [KMM92] J. Kollár, Y. Miyaoka, and S. Mori, *Rational connectedness and boundedness of Fano manifolds*, J. Differential Geom. **36** (1992), no. 3, 765–779.
- [KNP] A. Kasprzyk, B. Nill, and T. Prince, *Minimality and mutation-equivalence of polygons*. To appear in Forum Math. Sigma, arXiv preprint arXiv:1501.05335.
- [Kol13] J. Kollár, *Singularities of the minimal model program*, Cambridge Tracts in Mathematics, vol. 200, Cambridge University Press, Cambridge, 2013. With a collaboration of Sándor Kovács.
- [Kol91] ———, *Flips, flops, minimal models, etc*, Surveys in differential geometry (Cambridge, MA, 1990), 1991, pp. 113–199.
- [Kol96] ———, *Rational curves on algebraic varieties*, Ergebnisse der Mathematik und ihrer Grenzgebiete. 3. Folge. A Series of Modern Surveys in Mathematics, vol. 32, Springer-Verlag, Berlin, 1996.
- [KS98] M. Kreuzer and H. Skarke, *Classification of reflexive polyhedra in three dimensions*, Adv. Theor. Math. Phys. **2** (1998), no. 4, 853–871.
- [KSB88] J. Kollár and N. I. Shepherd-Barron, *Threefolds and deformations of surface singularities*, Invent. Math. **91** (1988), no. 2, 299–338.
- [KT] A. Kasprzyk and K. Tveiten, *Maximally mutable Laurent polynomials*. In preparation.
- [Lee01] Y.-P. Lee, *Quantum Lefschetz hyperplane theorem*, Invent. Math. **145** (2001), no. 1, 121–149.
- [LM] A. Laface and M. Melo, *On deformations of toric varieties*. arXiv preprint 1610.03455.

- [LN] Y. Lee and N. Nakayama, *Grothendieck duality and  $\mathbb{Q}$ -Gorenstein morphisms*. arXiv preprint arXiv:1612.01690.
- [Man09] M. Manetti, *Differential graded Lie algebras and formal deformation theory*, Algebraic geometry—Seattle 2005. Part 2, 2009, pp. 785–810.
- [Man86] Yu. I. Manin, *Cubic forms*, Second, North-Holland Mathematical Library, vol. 4, North-Holland Publishing Co., Amsterdam, 1986. Algebra, geometry, arithmetic, Translated from the Russian by M. Hazewinkel.
- [Mat89] H. Matsumura, *Commutative ring theory*, Second, Cambridge Studies in Advanced Mathematics, vol. 8, Cambridge University Press, Cambridge, 1989. Translated from the Japanese by M. Reid.
- [Mav] A. R. Mavlyutov, *Deformations of toric varieties via Minkowski sum decompositions of polyhedral complexes*. arXiv preprint arXiv:0902.0967.
- [MM03] S. Mori and S. Mukai, *Erratum: “Classification of Fano 3-folds with  $B_2 \geq 2$ ”* [*Manuscripta Math.* **36** (1981/82), no. 2, 147–162], *Manuscripta Math.* **110** (2003), no. 3, 407.
- [MM81] ———, *Classification of Fano 3-folds with  $B_2 \geq 2$* , *Manuscripta Math.* **36** (1981/82), no. 2, 147–162.
- [Mor82] S. Mori, *Threefolds whose canonical bundles are not numerically effective*, *Ann. of Math. (2)* **116** (1982), no. 1, 133–176.
- [MS05] E. Miller and B. Sturmfels, *Combinatorial commutative algebra*, Graduate Texts in Mathematics, vol. 227, Springer-Verlag, New York, 2005.
- [OP] A. Oneto and A. Petracci, *On the quantum periods of del Pezzo surfaces with  $\frac{1}{3}(1, 1)$  singularities*. To appear in *Adv. Geom.*, arXiv preprint arXiv:1507.08589.
- [Pri] T. Prince, *Smoothing toric Fano surfaces using the Gross-Siebert algorithm*. arXiv preprint arXiv:1504.05969.
- [Prz07] V. Przyjalkowski, *On Landau-Ginzburg models for Fano varieties*, *Commun. Number Theory Phys.* **1** (2007), no. 4, 713–728.
- [Ran89] Z. Ran, *Deformations of maps*, Algebraic curves and projective geometry (Trento, 1988), 1989, pp. 246–253.
- [Rie74] O. Riemenschneider, *Deformationen von Quotientensingularitäten (nach zyklischen Gruppen)*, *Math. Ann.* **209** (1974), 211–248.
- [Ser06] E. Sernesi, *Deformations of algebraic schemes*, Grundlehren der Mathematischen Wissenschaften, vol. 334, Springer-Verlag, Berlin, 2006.
- [Ste13] J. Stevens, *The versal deformation of cyclic quotient singularities*, Deformations of surface singularities, 2013, pp. 163–201.
- [Ste91] ———, *On the versal deformation of cyclic quotient singularities*, Singularity theory and its applications, Part I (Coventry, 1988/1989), 1991, pp. 302–319.
- [Tse10] H.-H. Tseng, *Orbifold quantum Riemann-Roch, Lefschetz and Serre*, *Geom. Topol.* **14** (2010), no. 1, 1–81.



- [TV13] M. Talpo and A. Vistoli, *Deformation theory from the point of view of fibered categories*, Handbook of moduli. Vol. III, 2013, pp. 281–397.
- [Vis89] A. Vistoli, *Intersection theory on algebraic stacks and on their moduli spaces*, Invent. Math. **97** (1989), no. 3, 613–670.
- [Vis] ———, *The deformation theory of local complete intersections*. arXiv preprint arXiv:9703008.
- [Zie95] G. M. Ziegler, *Lectures on polytopes*, Graduate Texts in Mathematics, vol. 152, Springer-Verlag, New York, 1995.