

<https://helda.helsinki.fi>

---

Emotional atmosphere in mathematics lessons in

Laine, Anu

Suomen ainedidaktinen tutkimusseura ry  
2013-12

---

Laine , A , Näveri , L , Ahtee , M , Hannula , M S & Pehkonen , E 2013 , Emotional  
atmosphere in mathematics lessons in third graders drawings . in M S  
Portaankorva-Koivisto , A Laine & L Näveri (eds) , Current state of research on mathematical  
beliefs XVIII: Proceedings of the MAVI-18 Conference, September 12-15, 2012, Helsinki,  
Finland . Suomen ainedidaktisen tutkimusseuran julkaisuja : Ainedidaktisia tutkimuksia , no.  
6 , Suomen ainedidaktinen tutkimusseura ry , Helsinki , pp. 27-38 . <  
[https://tuhat.halvi.helsinki.fi/admin/files/35130054/MAVI\\_18\\_proceedings.pdf](https://tuhat.halvi.helsinki.fi/admin/files/35130054/MAVI_18_proceedings.pdf) >

---

<http://hdl.handle.net/10138/230169>

---

publishedVersion

---

*Downloaded from Helda, University of Helsinki institutional repository.*

*This is an electronic reprint of the original article.*

*This reprint may differ from the original in pagination and typographic detail.*

*Please cite the original version.*

Current state of research on  
mathematical beliefs XVIII :  
Proceedings of the  
MAVI-18 Conference,  
September 12-15, 2012,  
Helsinki, Finland



Publications of the Finnish Research  
Association for Subject Didactics

Publications in Subject Didactics 6

Current state of research on  
mathematical beliefs XVIII :  
Proceedings of the  
MAVI-18 Conference,  
September 12-15, 2012,  
Helsinki, Finland

MARKKU S. HANNULA, PÄIVI PORTAANKORVA-KOIVISTO,  
ANU LAINE & LIISA NÄVERI (eds.)

Finnish Research Association  
for Subject Didactics



Chair:  
Professor Arto Kallioniemi  
Department of Teacher Education  
P.O. Box 9  
00014 University of Helsinki

---

Publications of the Finnish Research Association for Subject Didactics

Studies in Subject Didactics

Publications in this series have been peer reviewed.

Editorial board:

Liisa Tainio (chair), Kaisu Rättyä (secretary), Kalle Juuti, Henry Leppäaho,  
Eila Lindfors, Harry Silfverberg, Arja Virta and Eija Yli-Panula

Studies in Subject Didactics 6

Current state of research on mathematical beliefs XVIII

Cover and design:

Katja Kontu

Layout:

Mikko Halonen

Printing:

Unigrafia Oy, Helsinki

ISSN 1799-9596 (printed)

ISSN 1799-960X (pdf)

ISBN 978-952-5993-08-0 (printed)

ISBN 978-952-5993-09-7 (pdf)

<https://helda.helsinki.fi/>

Helsinki 2013

## Contents

Editorial	9
<b>Pupils' and students' views of mathematics</b>	<b>13</b>
9-year old pupils' self-related affect regarding mathematics: a comparison between Finland and Chile LAURA TUOHILAMPI, MARKKU S. HANNULA AND LEONOR VARAS	15
Emotional atmosphere in mathematics lessons in third graders' drawings ANU LAINE, LIISA NÄVERI, MAIJA AHTEE, MARKKU S. HANNULA AND ERKKI PEHKONEN	27
Enjoyable or instructive – lower secondary students evaluate mathematics instruction JANNIKA NEUMAN AND KIRSTI HEMMI	39
A good mathematics teacher and a good mathematics lesson from the perspective of Mexican high school students GUSTAVO MARTÍNEZ-SIERRA	55
Alex's world of mathematics HANNA VIITALA	71
Development of attitudes towards statistics questionnaire for middle school students and 8th grade students' attitudes towards statistics AYŞE YOLCU AND ÇİĞDEM HASER	83

**Adults' views on learning and doing mathematics** **97**

Challenging parental beliefs about mathematics education  
NATASCHA ALBERSMANN AND KATRIN ROLKA 99

Mixed methods in studying the voice of disaffection with school  
mathematics  
GARETH LEWIS 111

Gender differences in university students' view of mathematics  
in Estonia  
INDREK KALDO AND MARKKU S. HANNULA 121

Undergraduate mathematics students' career: a classification tree  
CHIARA ANDRÀ, GUIDO MAGNANO AND FRANCESCA MORSELLI 135

Why Johnny fails the transition  
FULVIA FURINGHETTI, CHIARA MAGGIANI AND FRANCESCA MORSELLI 147

Conceptions of research and of being a researcher among  
mathematics education doctoral students  
ÇİĞDEM HASER AND ERDİNÇ ÇAKIROĞLU 163

Feeling of innovation in expert problem posing  
IGOR KONTOROVICH AND BORIS KOICHU 175

Illumination: Cognitive or affective?  
PETER LILJEDAHL 187

## **Elementary teachers' views of mathematics and its teaching 201**

Inside teachers' affect:  
teaching as an occasion for math-redemption  
CRISTINA COPPOLA, PIETRO DI MARTINO, TIZIANA PACELLI AND  
CRISTINA SABENA 203

Pre-service teachers' possible mathematical identities  
SONJA LUTOVAC AND RAIMO KAASILA 217

(In)consistent? The mathematics teaching of a novice primary  
school teacher.  
HANNA PALMÈR 229

The association between lesson goals and task introduction in  
problem solving teaching in primary schooling  
LIISA NÄVERI, ANU LAINE, ERKKI PEHKONEN AND MARKKU S. HANNULA 243

Prospective teachers' conceptions of what characterize a gifted  
student in mathematics  
LOVISA SUMPTER AND EMMA STERNEVIK 259

Teachers' epistemic beliefs about mathematical knowledge for  
teaching two-digit multiplication  
JANNE FAUSKANGER 271

## **Secondary teachers' views of mathematics and its teaching 285**

Affective pathways and visualization processes in mathematical  
learning within a computer environment  
INÉS M<sup>a</sup> GÓMEZ-CHACÓN 287



Preservice mathematics teachers' metaphors for mathematics, teaching, and the teacher's role PÄIVI PORTAANKORVA-KOIVISTO	303
Finnish mathematics teachers' beliefs about their profession expressed through metaphors SUSANNA OKSANEN AND MARKKU S. HANNULA	315
Mathematics teachers' beliefs about good teaching: A comparison between Estonia, Latvia and Finland MADIS LEPIK, ANITA PIPERE AND MARKKU S. HANNULA	327
Out-of-field teaching mathematics teachers and the ambivalent role of beliefs – A first report from interviews MARC BOSSE AND GÜNTER TÖRNER	341
Teaching geometry interactively: communication, affect and visualisation MELISSA RODD	357
Secondary school teachers' statistical knowledge for teaching and espoused beliefs on teaching and learning of variability-related concepts ORLANDO GONZÁLEZ	371
Mathematics lessons as stories: linking semiotics and views of mathematics CHIARA ANDRÀ AND NATHALIE SINCLAIR	387





## Editorial

The 18th MAVI conference was organized by the University of Helsinki from September 12 to September 15, 2012. This is the proceedings of that conference. It is published in the series of the Finnish Research Association for Subject Didactics, as the sixth publication of the series and the first publication in English. We are grateful for the financial support by the University of Helsinki Faculty of Behavioural Sciences, which enabled the publication of this proceedings.

The MAVI conferences were initiated 1995 by Erkki Pehkonen and Günter Törner. They received funding from the Academy of Finland and the German DAAD for bilateral collaboration between the Universities of Helsinki and Duisburg for three years. By the time this funding ended, MAVI had grown into a community of researchers from 11 countries who continued to organize yearly meetings. However, no formal organization has been established. An important characteristic of MAVI conferences has been to give each participant an equal status; no keynote speakers have been invited and all papers have been given the same time for presentation and discussion. A more extensive account of the history of MAVI conferences is published in NOMAD (Pehkonen, 2012).

Following the procedure of last MAVI conferences, papers were submitted in advance for a peer review by three conference participants. In the conference we had 44 participants and altogether 28 papers were presented and intensively discussed. The conference was the largest in the history of MAVI and for the first time we had to split into parallel sessions. After the conference, the authors developed their papers based on the feedback they had received before and during the conference to produce the versions that appear in this proceedings.

Parallel to the production of this proceedings, the journal *Nordic Studies in Mathematics Education* (NOMAD) produced a thematic issue based on selected papers of the conference. Those conference papers that had received the most positive reviews were invited to be developed further and 11 of the conference papers were extended into full journal articles that appeared in the thematic issue of NOMAD 3-4, 2012.

The first section of the proceedings will consist of six papers looking into students' mathematics related affect in compulsory school. The first of these papers (Tuohilampi, Hannula & Varas) reports results of a likert-type survey of Finnish and Chilean 9-year olds' views of mathematics. As part of the same research project, the next paper (Laine, Näveri, Ahtee, Hannula & Pehkonen) uses drawings of the Finnish 9-year olds to assess the emotional atmosphere

in their classrooms. The following three papers all look at the lower secondary students' view of mathematics. Neuman and Hemmi used a likert-type questionnaire, Martinez-Sierra used a survey with open questions, and Viitala analyses interviews of one single student. Hence, these papers represent a range of methodological approaches used for studying beliefs. The last paper of this section (Yolcu & Haser) reports the development of an instrument and first results of students attitudes towards statistics.

The following eight papers focus on adults' views on learning and doing mathematics. The adults are facing mathematics as parents of mathematics learners (Albersmann & Rolka), as students in post-compulsory education (Lewis; Kaldo & Hannula; Andra, Magnano & Morselli and Furinghetti, Maggiano & Morselli), as doctoral students of mathematics education (Haser & Çakiroğlu) and as mathematicians (Kontorovich & Koichu and Liljedahl).

The next six papers focus on the mathematical affect of elementary teachers during their initial teacher education (Coppola, Di Martino, Pacelli & Sabena, Lutovac & Kaasila, and Sumpter & Sternevik), during their transition to work in schools (Palmèr) and as established professionals (Näveri, Laine, Pehkonen & Hannula, and Fauskanger).

Another eight papers look into the secondary teachers' views of mathematics and its teaching. Gómez-Chacón's paper explores the affective pathways as prospective secondary teachers solve problems with GeoGebra. The next two papers study prospective (Portaankorva-Koivisto) and in-service (Oksanen & Hannula) secondary teachers views of mathematics through the metaphors they use. The following paper (Lepik, Pipere, and Hannula) reports results of a comparative survey study of mathematics teachers' beliefs in Latvia, Estonia and Finland. The following three papers are focused around some specific questions that are relevant for mathematics teaching. Bosse and Törner are reporting the first results of their interviews with teachers who teach mathematics without a formal education for it. Rodd's paper discusses, in the light of psychoanalysis and neuroscience, the moment when the teacher is suddenly not able to visualise the geometrical theorem that s/he is in the middle of explaining. Gonzáles addresses the teachers' beliefs and knowledge for teaching in the area of statistics. This section and the whole proceedings closes with a semiotic analysis of a mathematics lesson to better understand the various ways in which teachers draw students' attention (Andrà & Sinclair).

Altogether the 18th MAVI conference provided varied perspectives to research on mathematics related affect. The papers that appear in this proceedings present

a rich selection of research methods, some of which are quite new in mathematics education research.

The editors

Markku S. Hannula

Päivi Portaankova-Koivisto

Anu Laine

Liisa Näveri

## References

Pehkonen, E. (2012). Research on mathematical beliefs: the birth and growth of the MAVI group in 1995–2012. *Nordic Studies in Mathematics Education*, 17(3-4), 7–22.



**PUPILS' AND STUDENTS' VIEWS OF  
MATHEMATICS**





# 9-year old pupils' self-related affect regarding mathematics: a comparison between Finland and Chile

LAURA TUOHILAMPI<sup>1</sup>, MARKKU S. HANNULA<sup>1</sup> AND LEONOR VARAS<sup>2</sup>

laura.tuohilampi@helsinki.fi,  
markku.hannula@helsinki.fi,  
mlvaras@dim.uchile.cl  
University of Helsinki<sup>1</sup>  
University of Chile<sup>2</sup>

## Abstract

*In the field of mathematics-related affect research, not many comparisons have been done with regard to Western-Latin countries. This article reports the state of 9-year old pupils' self-related affect with respect to mathematics in two countries, i.e. Finland and Chile. Self-efficacy, mastery goal orientation, effort, and enjoyment of mathematics were under consideration. Through quantitative analysis, it was found that all the factors examined are highly positive in both countries. However, a small difference with regard to beliefs of self-efficacy and effort was found between the countries, in favour to Finland. Yet, young pupils' self-related mathematical beliefs build up an optimistic view with respect to mathematics learning, and efforts should be made to maintain the situation similar during the following school years.*

## Keywords

*cross-cultural comparison, mathematics-related affect, young pupils*

## Introduction

According to previous research, mathematics-related affect concerning mathematics play a significant role when learning mathematics (e.g. Leder, 2006; Hannula, 2006; Op 't Eynde, De Corte, & Verschaffel, 2002). Unfortunately, several studies show that many of affective factors, such as self-efficacy feelings regarding mathematics, emotions towards mathematics, or self-confidence regarding mathematics, are far from positive. This is specifically seen with respect to teenagers, whereas the picture looks a bit more delightful when the concern is on younger students: according to Tuohilampi & Hannula (2011) primary school

pupils tend to have an optimistic view towards mathematics, and only when they become older the view begins to alter.

Affective factors, specifically *beliefs* seem to have a resilient nature: it is not easy to affect them, especially when it comes to self-related beliefs (Hannula, 2006). Further, once the belief structure has formed, the change from positive to negative seems to be more likely than from negative to positive. This includes, that despite the possibility that students might change their beliefs from positive to negative as they get older, it is necessary that as many pupils as possible adopt a positive view in the first case.

Argued by McLeod (1992), in addition to personal experiences, also the surrounding culture and society influence the formation and development of individual beliefs. However, these surroundings differ depending the place and time, and the relations between affective variables and achievement seem to have culturally specific characteristics (Lee, 2009). As an example, in a study of Zhu and Leung (2011) an “East Asian model” was searched, and the researches noticed that extrinsic motivation plays a very different role for East Asian students (Hong Kong, Japan, Korea, and Taiwan) than it does for Western students (Australia, England, USA, The Netherlands; the latter yet differing inside Western cultures as well).

To date, some of the cultural features in affective structures have been started to be acknowledged. Still, the concern has mostly been in the distinction of Western - Eastern cultures. Not much comparison is available between Western - Latin cultures. In this study, we aim to find out aspects of affect and its structure in two different cultures representing Western culture (Finland) and Latin culture (Chile). In addition to the cultures being different, the countries also differ in how their students have been performed in international assessments of mathematics, such as in PISA tests (OECD, 2010).

## Theoretical framework

According to Op ‘t Eynde and others (2002), a ”mathematical disposition”, that constitutes of cognitive, metacognitive, conative and affective factors is necessary in effective mathematics learning and problem solving. Such a disposition includes appropriate: a) knowledge base, b) using of heuristic methods, c) metaknowledge, d) mathematics-related beliefs, and e) self-regulatory skills. Having a disposition like that, students have sensitivity to situations and contexts to choose suitable actions in mathematics learning and problem solving.

It is generally assumed, that not only cognitive (a, b) or metacognitive (c) factors can capture the feature of mathematics learning and problem solving. Mathematics-related beliefs (d), including self-regulatory skills (e), are an important part of the disposition. For example, Op 't Eynde and others (2002) argue that conative and affective factors play as constituting elements of the learning process, in close interaction with cognitive and metacognitive factors. Further, they see conative factors perceived as fundamentally determine the quality of learning, and affective factors become important constituent elements of learning and problem solving. Those (affective) factors shape students' approach to problem solving (what strategies and processes will be used), they influence students' motivational decisions in mathematics learning and problem solving, and they have an impact on how the emotions towards mathematics develop.

The precise definition of beliefs has varied according to a researcher, yet certain features have been similar within the definitions. For example, in Goldin's (2002) view beliefs are "multiply-encoded, internal cognitive/affective configurations, to which the holder attributes truth value of some kind" (p. 59); whereas in Op 't Eynde and others' view beliefs are "implicitly or explicitly held subjective conceptions students hold to be true, that influence their mathematical learning and problem solving" (p. 24). These definitions of beliefs are fairly similar than Hannula's (2011) definition of *affective traits*, that are "mental representations to which it makes sense to attribute a truth value" (p. 43).

Beliefs may have a knowledge-type nature, (e.g. view of mathematic: "mathematics is calculating"), which truthfulness can be discussed in social interaction, or volitional nature (individual and subjective; such as "mathematics is important to me"). The latter kind of beliefs' validity can never be judged socially with any "scientific criteria". As beliefs are subjective, not necessarily "true", they differ from knowledge. However, the way they differ is not a straightforward question. According to Op 't Eynde and others (2002), knowledge is separated from beliefs with the distinction of social – individual. Beliefs and knowledge operate together: both determine students' understanding of specific mathematical problems and situations.

Stated by Op 't Eynde and others (2002), beliefs become from what is "first told". This means, that if there is nothing in a contradiction with given information (true or false), students tend to take it as true. Only when the contradiction appears, students have a reason to evaluate former beliefs, as well as given information in the light of former beliefs. The new information can be accepted or rejected:

even in contradiction, a false belief may remain dominant, as individuals have different significances to their beliefs.

Beliefs can be directed to different concerns. Students' mathematics-related beliefs can be structured into:

1. beliefs about mathematics education
2. beliefs about the self
3. beliefs about the social context (Op 't Eynde & al, 2002).

In this study, we will concentrate on the second aspect, beliefs about the self.

Inside these self-related beliefs, there are beliefs on the self-efficacy, control, task-value and goal-orientation (Op 't Eynde & al, 2002). Beliefs of the task-value and goal-orientation are thoroughly subjective, and their truthfulness cannot be evaluated socially or scientifically. What comes to the beliefs of the self-efficacy, one can estimate their actual level from outside, but the feeling of them is again subjective.

In addition to beliefs presented above, also emotional beliefs (e.g. enjoyment) or behavioral beliefs (e.g. effort) can be considered as self-related beliefs in spite of their different nature: beliefs can be seen either as a parallel concept in line with emotions and attitudes, or as a subconstruct of attitudes, parallel with emotions and behavior (Hannula, 2006).

Proceeding with the ponderings of the levels and hierarchy of affective factors, Hannula (2011) reminds that all factors of affect can be considered as a state or as a trait. In addition, they all have psychological, physiological and social manifestations. What comes to self-related beliefs, Hannula (2011) continues to suggest that effort can be seen as a motivational trait, and affects can be seen as a trait aspect of emotions. Further, Op 't Eynde and others (2002) claim that emotions are expressions of beliefs rather than beliefs as such.

However, when looking with the eyes of the students, the origin, the character or the category of an affective factor may seem irrelevant: they operate together and have implications to each other (e.g. Op 't Eynde & al, 2002). On the other hand, students may separate their beliefs concerning, for example, learning mathematics in their class from learning mathematics in general.

No matter the structure of the attitudes and affects, it is acknowledged, that they have implications to mathematics learning and problem solving. Self-efficacy

beliefs affect to how students venture to work with mathematics; effort and goal orientations imply students' resilience and initiative in mathematics; and emotions frame how students experience working with mathematics. Further, mathematics-related self-beliefs, motivation, and enjoyment of mathematics have statistically significant, though not very clear, connections (e.g. Hannula & Laakso, 2011).

Both the beliefs and their connections imply the students' performance in mathematics. Accordingly, they influence the belief structure in future: if the structure is positive at the beginning, it is more probable, that this is the case in the long run. To find out the situation of the belief structures with young pupils gives us important information about the starting point of the structure.

### Aim of the study

Following what has been presented with respect to theory of mathematics-related self-beliefs, this study presents the evaluation and the comparison of Chilean and Finnish 9-year old students' *self-efficacy feelings*, *effort*, *mastery goal orientations*, and *enjoyment of mathematics*. Further, we will examine the connections between the four factors of interest, and compare whether the connections are similarly structured and correspondingly strong in both countries.

### Methodology

It is clear that we cannot be sure whether we have been able to catch all the aspects of affect and beliefs at present. Accordingly, Leder (2006) reminds that the limitations of instruments, designed with the help of previous information, may influence on how the topic is measured, recognized and discussed further on.

Beliefs in quantitative studies are often measured by a questionnaire. This is an economic, fairly simple method that is familiar to many students. However, asking students to evaluate their beliefs through a questionnaire does not (necessarily) give information about the context at the moment. Further, it is possible that students' beliefs are affected by the questionnaire: for example, emotions may become stronger when there are provocative claims nourishing them. In this study, we acknowledge, that students' beliefs cannot undoubtedly be measured directly, but need to be inferred through students' self-reports or behavior (Leder, 2006). Consequently, we accept that the interpretation may be false, when the concern is on a beliefs per se, but if the focus is on what can be said about the reported beliefs' *connections* with mathematics learning or other beliefs, we rely

on previous findings: it is empirically and theoretically acknowledged, that data of students-reported beliefs gathered by empirical studies are real, existent and have implications to learning. For example, Leder (2006) marks that PISA results show that motivation, self-related beliefs and emotional factors have linked to students' learning strategies and thus to lifelong learning: the interpretation has been done using the gathered data, given by students.

In our study, we are interested on Finnish and Chilean 9-year old pupils' mathematics-related beliefs about self, and in particular self-related beliefs about *self-efficacy*, *mastery goal orientations*, *effort*, and *enjoyment* regarding mathematics and mathematics learning.

By examining beliefs about *self-efficacy*, we will find out the state of students' *feelings* of their *ability*. We have measured students' perception about their self-efficacy using items concerning *self-confidence* (e.g. "I am sure that I can learn math") and *self-competence* (e.g. "I have made it well in mathematics").

To find out the state regarding students' *mastery goal orientations*, we have items made explicitly to measure students' intentions to deeply orientate in mathematics learning (e.g. "On every lesson, I try to learn as much as possible". This will tell us about students' *values* with respect to mathematics learning.

By the items designed to measure *effort*, we will interpret what a student can *expect* to learn in mathematics, as effort is a trait of motivation. *Enjoyment* will tell us about the emotional circumstances of a student. This can be seen as an attitude, a trait aspect of emotions. Revealing the state of emotions we can infer what students' relation to mathematics is. Items to measure effort and enjoyment of mathematics have been designed to that particular purpose only (e.g. "I always prepare myself carefully for exams"; "I have enjoyed pondering mathematical exercises").

The data used in this study was gathered within an ongoing research aiming to develop mathematics learning in Finland and Chile. The data was collected during the academic year 2010-2011: September-October 2010 in Finland (Regions near to Helsinki) and February-March 2011 in Chile (Santiago). In Finland, the number of participants was 466, and in Chile 459, this makes the altogether number of participants 925. The project is funded by the Academy of Finland (project #1135556) and Chilean CONICYT. The overall aim is to develop a model for improving the level of pupils' mathematical understanding by using open problem tasks in mathematics teaching.

All the items used are part of a questionnaire developed by Hannula & Laakso (2011). The measurement was done using 3-point Likert scale: this is a common approach to the measurement of affect (Leder, 2006).

To analyze the sample, we first calculated the sum variables, and then checked the normality of the distributions. All the sum variables were skewed to the left: this means, that the answers were mainly positive, and almost none of the students chose the first category ("I don't enjoy mathematics", "I can't do mathematics" etc.). The reliabilities of the sum variables were between .512 - .663 for Chilean pupils and between .606 - .832 for Finnish pupils (Cronbach's alphas). In sum variables, the amount of missing cases varied between 30-46 (6%-10%) with regard to Finnish pupils, and between 58-94 (13%-20%) with regard to Chilean pupils.

We continued calculating the proportions of the answers in all of the categories. To make the comparison between the countries, a t-test was made. We chose the t-value according to the similarity or the non-similarity of the variances: Levene test was made to find out the case. As the distributions were skewed to the same directions, it was allowed to make parametric comparisons. Still, the results were confirmed using non-parametric tests.

Finally, the connections between the variables were examined. First, we checked the type of the possible connections from scatter plots: the connections were not clear, but if there was any, it was rather linear than something else. This suggested using Pearson correlation (parametric), though the confirmation was again done with Spearman correlation (non-parametric, based on order). When a non-parametric comparison was made, in all cases the results got confirmed. Because of that, all the results presented are based on parametric calculations.

## Results

The variables examined showed a very positive picture. With all the variables, the deviations were small, and the answers were almost thoroughly in the highest category. In the following, the explicit propositions, as well as the results of the t-tests between the countries according to each of the sum variables are presented.

### Self-efficacy

Finnish 9-year old pupils have high feelings about their *self-efficacy*. Most of the pupils (65 %) rate their self-efficacy feeling to be in the highest category. Only



few pupils (2 %) experience the opposite, i.e. rate their self-efficacy feeling to be in the lowest category.

Chilean 9-year old pupils have a bit more moderate self-efficacy feelings. About a third of the pupils (37 %) rate their self-efficacy feelings into the highest category. Most pupils (62 %) place their self-efficacy feeling into the middle category, while only some of the pupils (1 %) have the lowest self-efficacy feelings. See the table 1 for exact percentages.

A statistically significant difference between the two countries was found: Finnish students tend to have slightly stronger confidence on their self-efficacy (mean [F] = 2,63; mean [C] = 2,36;  $p < 0,001$ ).

*Table 1. Self-efficacy.*

<i>Self-efficacy (%)</i>	<i>low</i>	<i>middle</i>	<i>high</i>
Finland	2	33	65
Chile	1	62	37

## Effort

With respect to effort, the difference is quite the same. Most Finnish pupils (58 %) place the amount of their effort to be in the highest category. Few (2 %) state their effort to the lowest one.

In Chile, about a third (35 %) set their effort into highest category, and most pupils (64 %) into the middle category. Only one percent rates the amount of effort to the lowest category. To see the percentages, see table 2.

Again, a statistically significant difference between the two countries was found: Finnish pupils make stronger effort (mean [F] = 2,56; mean [C] = 2,34;  $p < 0,001$ ).

*Table 2. Effort.*

<i>Effort (%)</i>	<i>low</i>	<i>middle</i>	<i>high</i>
Finland	2	40	58
Chile	1	64	35

### Mastery goal orientation

Speaking of the *mastery goal orientation*, the picture is remarkably positive. Nearly all Finnish pupils (90 %) rate their orientation to be in the highest category. Almost none of the Finnish pupils (0,5 %) rate their orientation to the opposite category.

Also in Chile, almost every pupil (87 %) experiences the highest orientation. Only few pupils (1 %) feel the opposite; percentages are presented in table 3.

According to t-test, no statistically significant difference was found. Students have high and equal orientations in both countries (mean [F] = 2,9; mean [C] = 2,9;  $p=0,5$ ).

Table 3. *Mastery goal orientation.*

<i>Mastery goal orientation (%)</i>	<i>low</i>	<i>middle</i>	<i>high</i>
Finland	0,5	9,5	90
Chile	1	12	87

### Enjoyment of mathematics

Finnish pupils' emotions towards mathematics are mainly positive. Most pupils (66 %) enjoy mathematics, while quite a few pupils (6 %) do not. The picture is pretty same with Chilean pupils: Most pupils (61 %) enjoy mathematics, while only a handful (1 %) does not. See table 4 for the percentages.

An interesting detail is, that what comes to enjoyment, there are more pupils *not enjoying in Finland*, in spite of the fact that in Finland there are also more pupils enjoying. The situation is more polarized in Finland. However, a t-test result argues that there is not a statistically significant difference between the countries: on average, students enjoy equally in both countries (mean [F] = 2,6; mean [C] = 2,6;  $p=0,5$ ).

Table 4. *Enjoyment of mathematics.*

<i>Enjoyment of mathematics (%)</i>	<i>low</i>	<i>middle</i>	<i>high</i>
Finland	6	28	66
Chile	1	38	61

### Connections of the variables

Six type of connections were examined: MGO (=Mastery Goal Orientation) – effort; MGO – EoM (=Enjoyment of Mathematics); MGO – S-E (=Self-Efficacy); effort – EoM; effort – S-E; EoM – S-E.

According to scatter plots, the connections were either linear or there seem to be no connection at all. In all cases, strong connections were not visible in scatter plots. Still, all the correlations were statistically significant (\*\*). See table 5 for correlations.

*Table 5. Correlations.*

<i>Connection</i>	<i>correlation [FIN]</i>	<i>correlation [CHILE]</i>
MGO-Effort	.516	.297
MGO-EoM	.543	.386
MGO-S-E	.298	.369
effort-EoM	.484	.365
effort-S-E	.500	.309
EoM-S-E	.468	.462

In Finland, almost all the connections have quite similar correlations ( $r \approx 0,5$ ). This is the case in all connections except MGO – S-E: both goal orientations and self-efficacy go better in line with effort and enjoyment than they go in line with each other. This is not the case in Chile: MGO – S-E is the third strongest connection, though all in all, the connections are weaker in Chile than in Finland. What is noteworthy about the connection of MGO – S-E is that if there is a discrepancy between the two (goals are either unrealistic or a student do not really feel that he/she is able to reach them), it affects students enjoyment and achievement (Tuohilampi, 2011). A student needs to feel that the goals are achievable to not fall to helplessness.

Altogether, the connections are not remarkably high. The coefficient of determination ( $r^2$ ) range from 0,09 to 0,29, so none of the variables can clearly predict another one. One reason for that is that almost all the answers were in the highest category in all variables, and almost none of them were placed to the lowest one: for such a few cases existing in the categories outside the highest one it is hard to find a connection even there was one.

## Discussion

The self-related beliefs concerning mathematics seem to be delightfully positive with regard to Finnish and Chilean 9-year old students. Especially mastery goal orientations rated into the highest category almost exclusively in both countries: young pupils are eager to learn mathematics and they want to understand it deeply. Still, it is shown by Tuohilampi (2011) that it is important that the self-efficacy feelings follow the aspirations, otherwise students may lose their satisfaction to do mathematics, and even achievement may get worse.

Some differences between the countries were found: In Finland, pupils had little higher beliefs about their self-efficacy and effort. The differences were not remarkable, but in Chile, the pupils were a bit more heterogeneous, and the differences favored categorically Finnish pupils. As the belief structure may be less organized with regard to primary pupils than with respect to adolescents (Hannula & Laakso, 2011), the heterogeneity within the self-beliefs, as well as the weaker connections between them, seem to suggest that pupils in Finland may have developed their belief system more at the age of 9.

Students believe “what is first told”. This changes only when new information conflicts with previous perceptions (Op ’t Eynde & al, 2002; quotation marks by authors). As young pupils in this study had positive self-beliefs relating mathematics, they easily seem to accept that mathematics is nice, it is worthwhile to work with it, and they are able to do it. Secondary school students’ attitudes towards mathematics are poor compared to primary level students (Tuohilampi, 2011). A feeling of *being able* gets colored with uncertainty, the feeling of amusement moves towards hate or desperation, and many students wish to *perform* well, not necessarily *learn* well. Obviously, there are factors that impact the positive self-belief structure during the school years, making it more negative. Yet, to have a positive structure at the beginning is the proper starting point. Primary school pupils are enthusiastic to learn mathematics, so we need to be very careful to provide accessible mathematics in the following school years to make sure their capability feelings accompany.

## References

- Goldin, G. A. (2002). Affect, Meta-affect, and mathematical belief structures. In G. C. Leder, E. Pehkonen, & G. Törner (Eds.), *Beliefs: A Hidden Variable in Mathematics education?* (pp. 177-193). Kluwer Academic Publishers, Netherlands.

- Hannula, M. S. (2006). Affect in mathematical thinking and learning. In J. Maasz, & W. Schloeglmann (Eds.), *New mathematics education and practice* (pp. 209-232). Sense Publishers, Netherlands.
- Hannula, M. S. (2011). The structure and dynamics of affect in mathematical thinking and learning. In M. Pytlak, E. Swoboda, & T. Rowland (Eds.), *Proceedings of the 7<sup>th</sup> CERME conference* (pp. 34-60). Rzeszów, Poland: ERME.
- Hannula, M. S. & Laakso, J. (2011). The structure of mathematics related beliefs, attitudes and motivation among Finnish grade 4 and grade 8 students. In B. Ubuz (Ed.), *Proceedings of the 35th Conference of the International Group for the Psychology of Mathematics Education*, Vol. 3, (pp. 9-16). Ankara, Turkey: PME.
- Lee, J. (2009). Universal and specifics of math self-concept, math self-efficacy, and math anxiety across 41 PISA participating countries. *Learning and Individual Differences*, 19, (355-365).
- Leder, G. C. (2006). Affect and mathematics learning. In J. Maasz, & W. Schloeglmann (Eds.), *New mathematics education and practice* (pp. 203-208). Sense Publishers, Netherlands.
- McLeod, D. B. (1992). Research on affect in mathematics education: A reconceptualization. In D. A. Grows (Ed.), *Handbook of research on mathematics learning and teaching* (pp. 575-596). MacMillan, New York.
- OECD (2010). *PISA 2009 Results: What Students Know and Can Do – Student Performance in Reading, Mathematics and Science (Volume I)*.
- Op 't Eynde, P., de Corte, E., & Verschaffel, L. (2002). Framing students' mathematics-related beliefs. In G. C. Leder, E. Pehkonen, & G. Törner (Eds.), *Beliefs: A Hidden Variable in Mathematics education?* (pp. 13-37). Kluwer Academic Publishers, Netherlands.
- Tuohilampi, L. (2011). An examination of the connections between self discrepancies' and effort, enjoyment and grades in mathematics. In M. Pytlak, E. Swoboda, & T. Rowland (Eds.), *Proceedings of the 7th CERME conference* (pp. 1239-1248). Rzeszów, Poland: ERME.
- Tuohilampi, L., & Hannula, M. S. (2011). High expectations, low confidence – discrepancy in self-image as a reason for displeasure in mathematics. In B. Ubuz (Eds.), *Proceedings of the 35th Conference of the International Group for the Psychology of Mathematics Education*, Vol. 1, p. 406. Ankara, Turkey: PME.
- Zhu, Y., & Leung, F. S. (2011). Motivation and Achievement: Is There an East Asian Model? *International Journal of Science and Mathematics Education*, 9, 1189-1212.

## Emotional atmosphere in mathematics lessons in third graders' drawings

ANU LAINE, LIISA NÄVERI, MAIJA AHTEE, MARKKU S. HANNULA AND ERKKI PEHKONEN

anu.laine@helsinki.fi  
University of Helsinki, Finland

### Abstract

*The aim of this study was based on pupils' drawings to find out what kind of emotional atmosphere dominates in third graders' mathematics lessons. Pupils' (N = 133) drawings were analyzed by looking for content categories related to a holistic evaluation of mathematics lesson. As a summary we can conclude that the emotional atmosphere in the mathematics lessons is positive as a whole even though the differences between the classes are great. Furthermore, it can be said that drawings is a good and many-sided way to collect data about the emotional atmosphere of a class.*

### Keywords

*emotional atmosphere, mathematics lessons, pupils' drawings*

### Introduction

The Finnish National Core Curriculum for Basic Education (NCCBE 2004) provides descriptions of the aims of teaching mathematics as well as the meaning of mathematics in a pupil's intellectual growth: the purpose of education is to offer opportunities to develop pupils' knowledge and skills in mathematics, and in addition it should guide pupils towards goal-directed activities and social interaction. This aims to support pupils' positive stance towards mathematics and studying it. According to earlier research, third graders' attitude towards studying mathematics is fairly positive on average, the boys having a more positive attitude than the girls. The better the pupils were in mathematics, the more positive was their attitude. (Huisman, 2006.)

According to the National Core Curriculum for Basic Education (NCCBE 2004) the aim is to create a learning environment having an open, encouraging, easygoing, and positive atmosphere, and the responsibility to maintain this belongs to both the teacher and the pupils. The teacher has a central role in

advancing the affective atmosphere and social interaction in her/his class. Harrison, Clarke and Ungerer (2007) summarize that a positive teacher-pupil relation advances both pupils' social accommodation and their orientation to school, and it is thus an important foundation to the pupils' academic career in future.

Also positive friendships seem to increase pupils' active attendance to school. A pupil's advancement in school is connected to the factors that have an effect on social accommodation in the class like controlling emotions, liking school, eligibility as a mate, accommodation to school environment and self-control. In several studies, it has clearly been found, that there is a close connection between the atmosphere in the classroom and learning achievements as well as emotional and social experiences (e.g. Frenzel, Pekrun & Goetz 2007; Evans, Harvey, Buckley & Yan 2009).

The aim of this study is based on pupils' drawings to find out what kind of emotional atmosphere dominates in third graders' mathematics lessons.

#### Dimensions to the emotional atmosphere in a classroom

Evans et al. (2009) define to classroom atmosphere three complementing components: 1) academic, referring to pedagogical and curricular elements of the learning environment, 2) management, referring to discipline styles for maintaining order, and 3) emotional, the affective interactions within the classroom. In this study, we concentrate on the last component i.e. emotional atmosphere, which can be noticed e.g. as an emotional relation between the pupils and the teacher.

The emotional atmosphere within the classroom can be regarded either from the viewpoint of an individual (psychological dimension) or of a community (social dimension). Furthermore, a distinction can be made between two temporal aspects of affect, state and trait. State is a condition having short duration and trait is a more stable condition or property. These form a matrix shown in Table 1. (Hannula 2011.)

At an individual's level the rapidly appearing and disappearing affective states are on one hand different emotions and emotional reactions (e.g., fear and joy), thoughts (e.g., "This task is difficult."), meanings (e.g., "I could do it."), and aims (e.g., "I want to finish this task."). On the other hand, more stable affective traits are related to attitudes (e.g., "I like mathematics."), beliefs (e.g., "Mathematics

is difficult.”), values (e.g., ”Mathematics is important.”), and motivational orientations (e.g., ”I want to understand.”).

*Table 1. Dimensions to the emotional atmosphere in a classroom (see Hannula 2011).*

	<i>Psychological dimension or the level of an individual</i>	<i>Social dimension or the level of a community (classroom)</i>
<i>Affective condition (state)</i>	Emotions and emotional reactions Thoughts Meanings Goals	Social interaction Communication Atmosphere in a classroom (momentarily)
<i>Affective property (trait)</i>	Attitudes Beliefs Values Motivational orientations	Norms Social structures Atmosphere in a classroom

Different affective dimensions can be regarded also at the level of community i.e. of a classroom. Rapidly changing affective states include, for instance, a social interaction connected to a certain situation, communication related to this, and the emotional atmosphere present in the classroom. As an example one can think about the situation when the homework is being checked in the beginning of a mathematics lesson. This situation can differ quite a lot in different classrooms. In one classroom pupils are working in pairs and the atmosphere is jovial. In another classroom the teacher is walking around and s/he criticizes the pupils who have not done their homework. S/he also appoints certain pupils to go to present their solutions on the blackboard. The atmosphere in this classroom is tense.

When similar situations happen repeatedly in a classroom, students may form more stable affective traits typical to a certain classroom. Social norms (Cobb & Yackel 1996), social structures and atmosphere in a classroom are such traits. Pupils will ”learn” that during mathematics lessons homework is always checked in the same way, and a certain norm is developed. When also other parts of the mathematics lesson happen repeatedly in the same kind of atmosphere, the atmosphere may generalize to include all mathematics lessons, possibly also other lessons.



## Pupils' drawings as a research object

Many researchers (e.g. Aronsson & Andersson 1996; Murphy, Delli & Edwards 2004) have used pupils' classroom drawings, and realized that they form rich data to reach children's conceptions on teaching. Drawings can be used, e.g., to find out latent emotional experiences (Kearney & Hyle 2004). According to Harrison & al. (2007), drawings as indirect measurements tell more significantly about a pupil's accommodation to school than questionnaires and interviews. Also researchers in mathematics teaching (e.g. Tikkanen 2008; Dahlgren & Sumpter 2010) emphasize that one way to evaluate teaching are pupils' drawings about mathematics lesson. The drawings tell also about beliefs, attitudes and emotions related to mathematics. It has also been found that pupils begin, as early as in the second grade of elementary school, to form beliefs about good teaching (Murphy et al. 2004).

According to Blumer (1986), the meanings given by the pupils to various situations and things guide their actions, how they interpret different situations and what they include in their drawings. Giving meaning is a continuous process, which in this study takes place particularly in the social context of the mathematics lesson. Different pupils will find different meanings in the same situations. The meanings may have to do with physical objects, with social interaction, or with abstract things, such as the feelings that are elicited by teaching of mathematics. As a result of experiences gained from teaching, a pupil may evaluate himself as bad and their classmate as good in mathematics.

## The purpose of the study

This article is linked to the comparative study between Finland and Chile 2010-2013, a research project (project #1135556) funded by the Academy of Finland. The purpose of the project is to study the development of pupils' mathematical understanding and problem-solving skills from the third grade to the fifth grade when open tasks are used in teaching at least once a month. The data in this article consist of drawings that were collected in the autumn of 2010 as part of the project's initial measurements. In an earlier MAVI article based on these drawings teaching methods and communication in mathematics lessons were studied (Pehkonen, Ahtee, Laine & Tikkanen 2012).

In this article, the meanings the drawer gives to the events in a mathematics lesson are regarded in the social context of the lesson both from the pupil's point of view and the meanings of all the pupils in the classroom are combined to the atmosphere of the whole class. The research problem is thus: "What kind

of emotional atmosphere in a mathematics lesson can be seen in third-graders' drawings?" The holistic emotional atmosphere of a class describes the situation as a whole that can be concluded from the facial expressions and communication in the drawing. Here two levels of the emotional atmosphere during a mathematics lesson can be distinguished: a general emotional atmosphere as described by all the pupils, and the emotional atmosphere in a certain classroom.

The research questions are as follows:

1. What kind of emotional atmosphere in a mathematics lesson can be seen in third-graders' drawings?
2. How does the emotional atmosphere differ in different classes?

## Method

### Participants and data collection

The third-graders (about 9-10 years old) came from the classes of nine different teachers in five primary schools in the Helsinki metropolitan area. The pupils drew a mathematics lesson scenario as their task in the beginning of the 2010 autumn term. The task given to the pupils was: "Draw your teaching group, the teacher and the pupils in a mathematics lesson. Use speech bubbles and thought bubbles to describe conversation and thinking. Mark the pupil that represents you in the drawing by writing ME." In total 133 pupils' drawings were analysed, out of which 71 were drawn by boys and 62 by girls. The words in the speech and thought bubbles enabled the study of communication between the teacher and pupils.

### Data analysis

According to the analyzing method used by Tikkanen (2008) in her dissertation, a drawing as an observational data can be divided into content categories. A content category means a phenomenon on which data are gathered. A content category is further specified into subcategories. In this article, we are concentrating only on *the holistic evaluation of the emotional atmosphere in a classroom* which is based on all the pupils' mood as well as on the teacher's mood seen in a drawing. The pupils' and the teacher's mood is determined on the form of the mouth and on speech and thought bubbles: positive (all smile and/or think positively, part can be neutral); positive and negative (ambivalent), if at least two opposite (positive or negative) facial or other expression; negative (all are sad or angry or think negatively); neutral, when it is impossible to decide whether the persons' facial

or other expressions are positive or negative. Example of the coding of both facial expressions and speech/thought bubbles is presented in figure 1.

Pupils' drawings varied a lot especially from the analyzing point of view. The clarity of pupils' drawings was therefore evaluated by using a three step scale: 1. A clear drawing in which it is possible to see in addition to the facial expression many details. 2. The facial expression can be distinguished. 3. No facial expression can be seen; the class is drawn e.g. in such an angle that only the top of the head can be seen. The boys' and the girls' drawings differed very significantly. Only two boys compared to 17 girls drew pictures in which there were many details in addition to the facial expression (4.17\*\*\*), and, respectively, half of the girls drew pictures in which one could see the facial expressions compared to about 15% of boys' drawings (4.40\*\*\*). No significant difference was found between the speech and thought bubbles drawn by the boys (401/71= 5,6) and girls (313/62= 5,0).

Three researchers classified the pupils' drawings first by themselves, and then in the case of difference of opinions (in about 10 % of the drawings), the drawings were re-examined together. Problems in classification were mostly due to pupils' confusing drawings. The analysis of the drawings was qualitative, and it can be classified as inductive content analysis (Patton 2002), as we were trying to describe the situation in the drawing without letting our own interpretations influence it. The drawings were analysed one content category at a time. Each drawing was examined to see if sub-categories of the main content category could be found.

### An example of coding

In Figure 1, a drawing of a boy is shown as an example. In the drawing the holistic evaluation of the emotional atmosphere in a classroom is positive as all the pupils as well as the teacher are smiling. Furthermore, both the teacher's and the pupils' speeches or thoughts are either positive or neutral.

The drawer (*minä*) is smiling and thinking that ("*Rounding is easy.*"). The teacher is the tallest figure in the drawing. She is asking ("*Does anyone want help?*"). In the upper row starting from left a pupil asks ("*Where is the pencil?*"). The pupil sitting in the next desk says or thinks ("*Jokerit* (a Finnish hockey team) *is the best.*"). The pupil standing near this desk says or thinks ("*Hockey cards*"). The pupil in the right corner says ("*Pencil*"). All these talks or thoughts were evaluated as neutral. In the bubbles of the pupils sitting in the lower row opposite to each other is written ("*Easy*") and ("*I want.*"). The latter pupil is probably answering the teachers question but as she/he is smiling this remark was interpreted as

neutral. The pupil in the lower corner says or thinks that ("Oilers (a Finnish floor ball team) *is winning*." ) The clarity of the drawing is 2 because it is possible to identify the person's facial expressions but not any details like for example their sex.

The pupils' drawings are informative, as evident in the example of Figure 1. In many drawings only stick figures can be seen, in a few of them the hands start at the face, and in some of them pupils are just represented by their desks. However, some of the third-graders are very talented illustrators, and then the drawings contain many details. The pupils' thoughts about the mathematics lesson and the classroom atmosphere are written in bubbles, though the pupils' presentation of a turn of speech – either aloud or by whispering – or thinking in bubbles is not always logical.

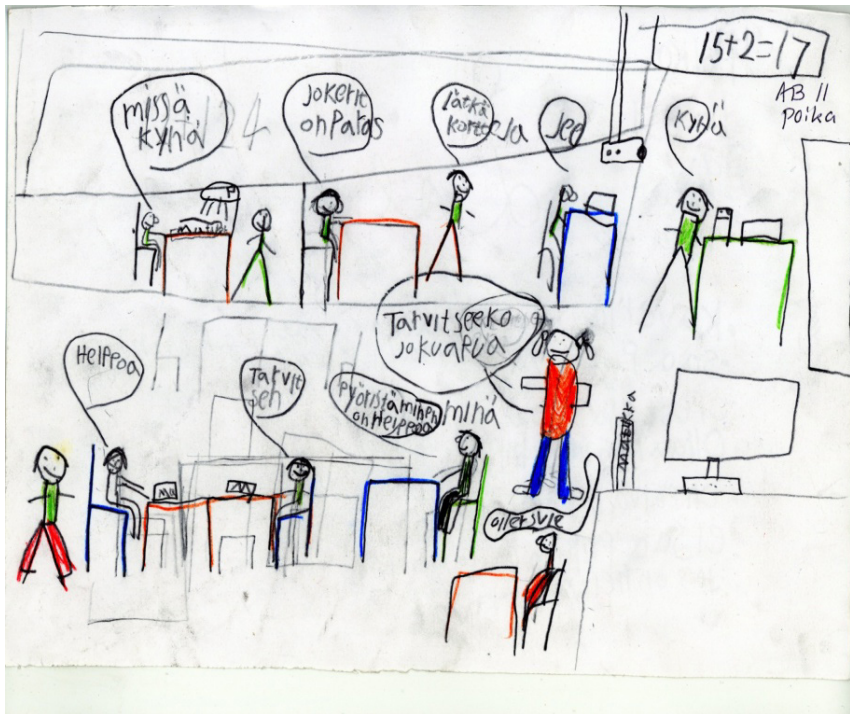

Figure 1. A third-graders' drawing about mathematics lesson.

## Results

### Emotional atmosphere in a mathematics lesson

The emotional atmosphere in a mathematics lesson is taken as an entirety that consists of the pupils' and the teacher's facial expressions and their utterances or thoughts. It is classified using the scale: positive, ambivalent, negative, neutral, and unidentifiable. The summary of emotional atmosphere of a mathematics lesson based on the third-graders' drawings is presented in Table 2.

*Table 2. Emotional atmosphere in a third-grader's mathematics lesson (number; percentage) <sup>s</sup> significance of the difference 2,41\*.*

	<i>positive</i>	<i>ambivalent</i>	<i>negative</i>	<i>neutral</i>	<i>unidentifiable</i>
total (133)	50; 38%	44; 33%	13; 10%	20; 15%	6; 5%
girls (62)	30; 48% <sup>s</sup>	19; 31%	5; 8%	7; 11%	1; 2%
boys (71)	20; 28% <sup>s</sup>	25; 35%	8; 11%	13; 18%	5; 7%

The mode of the emotional atmosphere in mathematics lessons is positive (50; 38%), with both the teacher and all the pupils smiling (or some of them neutral) or thinking positively/ neutrally. A third of the pupils have drawn the emotional atmosphere in the classroom as ambivalent which means that in their drawings is at least one person whose facial expression is sad or angry or who says (or thinks) something that is interpreted to be negative. The difference between positive and ambivalent sub-categories is not large, as the latter category contains also the drawings in which among many smiling pupils there is one pupil showing sad face. It can thus be said that the total picture about the mood in the classroom is positive in the third graders' drawings on mathematics lesson. Girls' drawings are almost significantly more positive than boys' drawings i.e. girls used more positive expressions in their drawings than boys.

### Emotional atmosphere in different classrooms

Next we are looking at classroom-specific emotional atmosphere in mathematics lesson found in the third-graders' drawings. The summary of emotional atmosphere in different classrooms is presented in Table 3.

Even though the modal value of the emotional atmosphere in mathematics lessons is positive in the total data (see Table 2), there are large differences among the different classrooms. In four classrooms (A, B, C and D) the emotional atmosphere of the classroom can be interpreted as positive because the mode of the emotional atmosphere is positive in these classrooms (see Table 3). More than 50% of the pupils in classroom A presented the atmosphere in the classroom as positive; on the other hand, classroom A has the second highest frequency of drawings that represent a negative atmosphere in the classroom. The emotional atmosphere in classroom B can be interpreted particularly positive because only 14% of the pupils had drawn it negative or ambivalent. On the other hand, none of the drawings in classroom D were interpreted negative. Classroom C represents an average emotional atmosphere in third graders' mathematics lesson.

*Table 3. Emotional atmosphere in mathematics lesson in the classrooms (number; percentage).*

	<i>Positive</i>	<i>Ambivalent</i>	<i>Negative</i>	<i>Neutral</i>	<i>Unidentifiable</i>
A (15 pupils)	8; 53%	4; 27%	3; 20%	0; 0%	0; 0%
B (14 pupils)	7; 50%	1; 7%	1; 7%	3; 22%	2; 14%
C (19 pupils)	9; 47%	7; 37%	2; 11%	0; 0%	1; 5%
D (18 pupils)	8; 44%	6; 33%	0; 0%	2; 11%	2; 11%
E (16 pupils)	4; 25%	2; 13%	1; 6%	9; 56%	0; 0%
F (17 pupils)	5; 29%	4; 24%	0; 0%	8; 47%	0; 0%
G (17 pupils)	2; 12%	5; 29%	5; 29%	4; 24%	1; 6%
H (11 pupils)	4; 36%	5; 46%	1; 9%	1; 9%	0; 0%
I (6 pupils)	2; 33%	4; 67%	0; 0%	0; 0%	0; 0%
average (133 pupils)	49; 37%	38; 29%	13; 10%	27; 1%	6; 4%

In three classrooms (G, H and I) the emotional atmosphere in the pupils' drawings is ambivalent i.e. the pupils' drawings contain both positive and negative elements.

The emotional atmosphere in classroom I can be interpreted very positive because none of the pupils described it negative. On the other hand, in classroom G more than half of the pupils described in their drawings the atmosphere in mathematics lesson negative or ambivalent and only a small portion of the pupils described it positive. The emotional atmosphere in this classroom differs very clearly from the average emotional atmosphere in mathematics lesson. In the drawings, the atmosphere in classrooms E and F is neutral.

## Conclusions

In the Finnish third-graders' drawings the mode value of the emotional atmosphere in mathematics lesson is positive. This matches also the result obtained in the connection learning outcomes in mathematics in the beginning of the third grade (Huisman 2006) namely that the third-graders' collective attitude towards studying mathematics was fairly positive. However, the boys had a more positive attitude than the girls. It is interesting that according to our study the emotional atmosphere in mathematics lesson is more positive when described by the girls than by the boys (see Table 1). This result does not totally forbid the possibility that boys in third grade react more positively towards mathematics than girls as found by Huisman (2006). However, it seems possible to obtain more information to this many-sided question with the aid of pupils' drawings (see e.g. Kearney & Hyle 2004).

The most interesting result in this study is large differences between the emotional atmospheres in different classrooms. The Finnish National Core Curriculum for Basic Education (NCCBE 2004) sets the aim to foster a positive atmosphere in all the classrooms. The teacher has a central role in constructing the emotional atmosphere in mathematics lessons (Evans et al. 2009; Harrison et al. 2007). The teacher's view of mathematics, their stance towards pupils, their pedagogical skills etc. affect the quality of interaction with pupils and thus also the emotional atmosphere. Especially, the emotional relationship between the teacher and the pupils, the teacher's awareness about pupils' feelings and the reasons for these, the teacher's skill to evaluate pupils' feelings and respond to them, the teacher's conception about the importance of different emotions in learning, and the teacher's emotional interpersonal guidelines affect the emotional atmosphere (Evans et al. 2009).

When evaluating a teacher's effect in this study one has to take into account that the third-graders made their drawings already in September 2010 when they had gone to school for only one month after the summer holiday. Pupils' conceptions on the emotional atmosphere in mathematics lesson have thus been

affected mainly the two former school years. On the other hand, a pupil's affective conditions and properties affect how they interpret different situations during mathematics lessons (Hannula 2011). It would be interesting to study what the emotional atmosphere is like in the lessons of other subjects.

To some extent it was difficult to interpret pupils' drawings. The pupils were fairly young and therefore their drawing skills varied a lot. Some of the teachers had clearly let pupils to use more time to make their drawings and some of them had guided more carefully that some conditions had been fulfilled (e.g. that "ME" was clearly marked in the drawing). It will be interesting to see how the improvement in drawing skill will affect on the distribution of facial expressions.

As a summary, drawings seem to be a versatile way to collect information about emotional atmosphere in mathematics lessons (see also e.g. Harrison et al 2007). The method offers also a single teacher a possibility to obtain and evaluate information how their pupils experience mathematics and mathematics lessons.

## References

- Aronsson, K., & Andersson, S. (1996). Social scaling in children's drawings of classroom life: A cultural comparative analysis of social scaling in Africa and Sweden. *British Journal of Developmental Psychology* 14, 301–314.
- Blumer, H. (1986). *Symbolic interactionism. Perspective and Method*. Berkeley: University of California Press.
- Cobb, P., & Yackel, E. (1996). Constructivist, Emergent, and Sociocultural Perspectives in the Context of Developmental Research. *Educational Psychologist* 31 (3/4), 175-190.
- Dahlgren, A., & Sumpter, L. (2010). Childrens' conceptions about mathematics and mathematics education. In K. Kislenco (ed.) *Proceedings of the MAVI-16 conference June 26-29, 2010*, s. 77–88. Tallinn University of Applied Sciences, Estonia.
- Evans, I. M., Harvey, S. T., Buckley, L., & Yan, E. (2009). Differentiating classroom climate concepts: Academic, management, and emotional environments. *New Zealand Journal of Social Sciences* 4 (2), 131-146.
- Frenzel, A. C., Pekrun, R., & Goetz, T. (2007). Perceived learning environment and students' emotional experiences: A multilevel analysis of mathematics classrooms. *Learning and Instruction* 17 (5), 478—493.
- Hannula, M. S. (2011). The structure and dynamics of affect in mathematical thinking and learning. In M. Pytlak, E. Swoboda & T. Rowland (eds.) *Proceedings of the seventh Congress of the European Society for Research in Mathematics Education CERME*, s. 34-60. Poland: University of Rzesów.



- Harrison, L. J., Clarke, L., & Ungerer, J. A. (2007). Children's drawings provide a new perspective on teacher-child relationship quality and school adjustment. *Early Childhood Research Quarterly* 22, 55-71.
- Huisman, T. (2006). *Luen, kirjoitan ja ratkaisen. Peruskoulun kolmasluokkalaisten oppimistulokset äidinkielessä. kirjallisuudessa sekä matematiikassa.* [I read, I write and I solve. A third grader's learning outcomes in Finnish, literature and mathematics]. Oppimistulosten arviointi 7/2006. Helsinki: Opetushallitus.
- Kearney, K. S., & Hyle, A. (2004). Drawing about emotions: the use of participant-produced drawings in qualitative inquiry. *Qualitative Research* 4(3), 361-382.
- NCCBE 2004. Finnish National Core Curriculum for Basic Education 2004. [http://www.oph.fi/english/publications/2009/national\\_core\\_curricula\\_for\\_basic\\_education](http://www.oph.fi/english/publications/2009/national_core_curricula_for_basic_education).
- Patton, M. (2002). *Qualitative research & evaluation methods*. Thousand Oaks: Sage.
- Pehkonen, E., Ahtee, M., Tikkanen, P., & Laine, A. (2011). Pupils' conceptions on mathematics lessons revealed via their drawings. In B. Rösken & M. Casper (Eds.) *Current State of Research on Mathematical Beliefs XVII. Proceedings of the MAVI-17 Conference*, pp. 182–191. University of Bochum.
- Tikkanen, P. (2008). "Helpompaa ja hausempaa kuin luulin." *Matematiikka suomalaisten ja unkarilaisten perusopetuksen neljäsluokkalaisten kokemana.* ["Easier and more fun than I thought." Mathematics experienced by by fourth-graders in Finnish and Hungarian comprehensive schools.] *Jyväskylä Studies in Education, Psychology and Social Research* 337. Jyväskylä: Jyväskylä University Printing House.

## Enjoyable or instructive – lower secondary students evaluate mathematics instruction

JANNIKA NEUMAN AND KIRSTI HEMMI

jannika.neuman@mdh.se  
Mälardalen University, Sweden

### Abstract

*In this paper we present results from an ongoing study of students' attitudes towards their mathematics education and beliefs about themselves as mathematics learners from two Swedish lower secondary schools (n=185) that are taking part in the mathematics initiative established by the government. Our study also focuses on students' attitudes towards and beliefs about mathematics instruction. The students consider a majority of the most commonly used working methods in the mathematics classrooms to be boring, while at the same time they regard these methods as the most instructive. An important result for school teachers to consider in ongoing mathematics projects is that many students (about 60%) feel the mathematics tasks they are confronted with in lessons are too easy.*

### Keywords

*beliefs, attitudes, lower secondary students, working methods in mathematics*

### Introduction

Current research shows a positive correlation between students' attitudes towards mathematics education and their results in mathematics (e.g. Granström & Samuelsson, 2007). Also, students' self-confidence and performance in mathematics have proven to be highly correlated in the upper grades of compulsory school (e.g. Linnanmäki, 2004). Additionally, a positive attitude towards mathematics and students' self-confidence are stated as goals in the mathematics curricula of many countries (Mullis, Martin & Foy, 2008). However, if we look at the Trends in International Mathematics and Science Study [TIMSS] over time, for eighth graders, there is a general tendency of less and less positive affect towards the subject.

During the past decade the mathematics results of Swedish secondary school students have been decreasing according to international and national

evaluations, and the number of students failing to pass the subject in the ninth grade has increased. Students' attitudes towards mathematics is an issue that has attracted attention in the school debate in Sweden, and several goals with respect to students' interest in mathematics are stated in both the previous Swedish curriculum (Lpo94) and the most recent one (Lgr11). Despite this, less than half of Swedish eighth graders show a positive attitude towards mathematics (Mullis et al., 2008). The 2003 national evaluation of Swedish compulsory school also shows an increasing polarisation regarding students' attitudes and beliefs. For example, the number of students stating that many mathematics tasks they are confronted with are too easy has increased, but so has also the number of students who find the tasks too challenging. The students consider knowledge in mathematics important, but at the same time not many of them find the subject interesting compared to other subjects. Finally, students' self-esteem is shown to be rather high, although these figures are decreasing (Skolverket, 2005).

The National Agency for Education advocates a more varied mathematics teaching approach, and points out that students should have the possibility to take part in the planning and evaluation of the teaching (Skolverket, 2003). Various working methods may have different impacts on students' identities and their learning of mathematics, and might also be effective in achieving different learning goals (Hiebert & Grouws, 2007). A varied teaching approach can improve students' attitudes towards mathematics. In a more diverse mathematics teaching approach, in which different working methods are used and students interact with the teacher and each other, students do not perceive mathematics as boring since they feel more involved in the learning process (cf. Kariuki & Wilson, 2002). However, we have little knowledge about students' beliefs about mathematics instruction (cf. McLeod, 1992). This is something we especially focus on in our paper.

Due to reports of declining results, ineffective teaching and low interest in mathematics, the Swedish government has initiated several developmental programs during the past decade. Our study takes place within the latest initiative, which allowed schools to apply for money to develop their mathematics instruction and improve students' target achievements in the subject (see Johansson, 2011). Many schools that received money from the Swedish National Agency for Education (Skolverket) aimed to introduce new working methods in mathematics education and depart from a textbook dominance to more experimental mathematics in order to provide a more enjoyable learning environment for students (Skolverket, 2011a). Two of these schools wanted to study students' attitudes towards their mathematics education and clarify the students' wishes concerning mathematics teaching before and after the project

implementation, and our university helped them with the evaluation. The results presented in this paper come from an ongoing analysis of the data from two studies conducted at the beginning of the projects. We examine the students' attitudes towards their mathematics education and beliefs about themselves as mathematic learners. Focus is also on students' attitudes towards different ways of working during mathematics lessons and how they assess their own learning relative to these ways of working. We have stated the following research questions:

- What are the students' attitudes towards their mathematics education and different working methods?
- What are the students' beliefs about themselves as mathematics learners?
- How do the students assess their own learning relative to the various working methods?

## Beliefs, attitudes and emotions

McLeod (1992) divides the affective responses to mathematics education into beliefs, attitudes and emotions. These three terms are all connected, but vary in stability, intensity, cognitive appraisal and the time they take to develop. Though there is a general agreement to divide the affective domain into these three constructs, the definition of them is not undisputed and many times the words "beliefs" and "attitudes" are used synonymously (Di Martino & Zan, 2011). In this paper we do not try to formulate a comprehensive definition of the concepts, but merely point out some aspects that are of relevance to our study.

In mathematics education two various definitions of attitude are particularly popular; the multidimensional and the simple definition. In this study we assume the simple definition where an attitude is seen as "a general emotional disposition toward a certain subject" (Di Martino and Zan, 2001, p.18). Hannula (2002, p.29) points out that in the case of a questionnaire:

*... the first reaction is usually emotional and based on associations. These automatic associations are a product of the student's previous experiences with mathematics. This second process falls under the simple definition of attitude as an emotional disposition.*

According to McLeod (1992), one's attitude towards mathematics can involve aspects such as liking geometry, enjoy problem-solving and being bored by algebra. We explore students' attitudes towards their mathematics education and which ways of working they find enjoyable.

In the field of mathematics education there are many variations of the concept belief and it is difficult to give an explicit and shared definition (Furinghetti & Pehkonen, 2003). In many studies the lack of an explicit definition can make it hard to understand what is being investigated (Di Martino & Zan, 2011). As advised by Furinghetti and Pehkonen (2003) we consider beliefs as belonging to subjective knowledge. The beliefs studied are seen as affective and possible to change under the right circumstances. Otherwise, the didactic activities would seem useless.

The concept beliefs concern different fields of mathematics education and McLeod (1992) divides students' beliefs into four categories: beliefs about mathematics, beliefs about the contexts in which mathematics education occurs, beliefs about self and beliefs about mathematics teaching. We focus on the latter two. Beliefs about self include concepts like self-concept and confidence, for example believing that you are good at mathematics. Beliefs about mathematics teaching involve, among others, beliefs about instructions and we investigate which mathematics instruction the students find instructive. However, students' ability to evaluate their own achievements and learning can be a complicated issue. Boekarts & Corno (2005) stress that the learning goals teachers have in mind are not always adopted by their students. And if they are adopted, students sometimes find it difficult to work effectively towards these goals since they value things like entertainment and well-being higher. This may cause students to choose less effective strategies to achieve the learning goals. Furthermore, students' beliefs about themselves and mathematics teaching can affect their self-regulation. For example, if a student believes learning mathematics should be easy and that effort is unimportant, this could lead to a choice not to engage in effective learning strategies (Butler & Winne, 1995). Hence, what students think are good strategies are not necessarily always the most effective for achieving the learning goals.

## Methodology

The students participating in the study came from two Swedish lower secondary schools situated in small cities (see manufacturing municipalities in Johansson, 2011). Compared to the national average, one of the schools had a higher proportion and the other a lower proportion of students passing the subject of mathematics in the ninth grade. Both schools had been granted money from the National Agency for Education and participated in the national mathematics initiative. The questionnaire used in the study was developed during a final degree project (see Neuman, 2011). The teachers at the participating schools were allowed to propose changes to the questionnaire, and it was piloted. Almost the

same questionnaire, with a few changes, was used in a similar study at another school (Cervin, 2011).

The questionnaire consisted of a number of statements about students' relation to mathematics and mathematics teaching. The students were asked to rate their agreement with these statements on a four-step scale. We also posed questions about commonly used working methods in mathematics education. On a five-step scale, the students were to classify the working methods as enjoyable or boring and instructive or not instructive. A total of 188 students aged 12-16 (grades 6-9) took part in the study. Three questionnaires were only partially filled in, so the total number of analyzed questionnaires was 185. Not all the results obtained from the studies (Neuman, 2011; Cervin, 2011) are presented in this paper. The gathered data allowed us also to conduct further statistical investigations.

In our data analysis we first used descriptive statistics to summarize and organize the data. Some initial answers to our research questions could be given by this analysis. We are now in the beginning of a deeper data analysis and present some of the results obtained so far. A hierarchical cluster analysis using Ward's method was run on 7 cases responding to items on the students' attitudes toward their mathematics education and beliefs about them self as mathematic learners. Only 172 students could be involved in the cluster analysis because it requires an answer for every variable. Independent sample t-tests were conducted to compare the mean values of the cases for the clusters and to see if there were any significant difference between the clusters attitudes and beliefs about different working methods. The correlation presented in this paper was tested using a two-tailed Spearman's rho test. No significant differences have been found thus far between the two schools concerning the results of the data analysis we have conducted. Hence, we present the results for the two schools together.

## Results

Table 1 shows that mathematics is not especially popular among the students at the two focus schools. 63% disagree or strongly disagree with the statement *Mathematics is one of the topics I like best in school*. Less than half of the students look forward to their mathematics lessons, and 59% agree or strongly agree with the statement *Most of the tasks in mathematics are too easy for me*. However, at the same time, a strong majority are satisfied with their mathematics education in general as 88% agree or strongly agree with the statements *I am satisfied with the mathematics teaching I receive today* and *In school I get enough help in mathematics*. Just like in the national evaluation from 2003, the students consider mathematics

useful for them as 92% agree or strongly agree with the statement *I will have use for the mathematics I learn in school*. The students' self-conception is good: three out of four students believe they are good at mathematics. There is also a significant positive correlation (0.40 at the 0.01 significance level) between the statements *I am good at mathematics* and *Most of the tasks in mathematics are too easy for me*. This shows that students who believe they are good at mathematics, compared to those who believe the opposite, more often feel the mathematics tasks are too easy for them.

*Table 1. Students' responses to statements about attitudes towards mathematics education and beliefs about themselves as mathematics learners. The maximum value for the mean is 4 and the minimum value is 1.*

<i>Statement</i>	<i>Strongly agree or agree</i>	<i>Strongly disagree or disagree</i>	<i>Mean</i>	<i>Standard deviation</i>
Mathematics is one of the topics I like best in school	37%	63%	2,17	0,98
I look forward to mathematics lessons	41%	59%	2,31	0,77
I will have use for the mathematics I learn in school	92%	8%	3,43	0,70
Most of the tasks in mathematics are too easy for me	59%	41%	2,66	0,78
I am satisfied with the mathematics teaching I receive today	88%	12%	3,20	0,76
In school I get enough help in mathematics	88%	12%	3,28	0,73
I am good at mathematics	75%	25%	2,83	0,91

A cluster analysis run on the seven statements in Table 1 produced two clusters, between which the variables were significantly different in the mean (Appendix 1). The first cluster was predominant (n=129) and characterized by more positive attitudes towards their mathematics education and more self-confidence in mathematics than cluster two (n=43).

Regarding students' attitudes towards different working methods in mathematics, *use of other material than textbooks* (computer, games, etc.) was seen as the most enjoyable with a mean-value of 4,16. Concerning instructiveness, less than half the students assigned the working method a 4 or a 5 which gave it a mean-value of 3,46. This means that three other working methods were considered more instructive. Compared to the other working methods, *group work* and *working in pairs* were also regarded as quite enjoyable. One of the two working methods most of the students found instructive was *joint review with the teacher*. Yet, with a mean-value of 2,89 less than a third of the students experienced it as enjoyable. The least enjoyable working method, according to the students, was *homework*. However, *working with textbooks* and *individual work* were also considered boring, as a significantly larger proportion of students gave these working methods a 1 or 2 instead of 4 or 5. But if we instead choose to look at how instructive they found the working forms *individual work* and *working in textbooks*, they regarded these as the most and third most instructive methods (Table 2).

Table 2. How enjoyable and instructive the students found different working methods. A rating of 5 reflects the most enjoyable or instructive alternative. SD stands for standard deviation.

Working method	Have worked with	Enjoyable		Instructive	
		Mean	SD	Mean	SD
Individual work	100%	2,72	1,21	3,78	0,89
Work in pairs	81%	3,52	1,01	3,38	0,91
Group work	78%	3,48	1,05	3,32	0,94
Work with textbooks	98%	2,64	1,22	3,72	0,95
Other material than textbooks	75%	4,16	0,96	3,46	0,98
Joint review with the teacher	99%	2,89	1,11	3,78	1,07
Problem-solving	81%	2,97	1,34	3,27	1,09
Laboratory work	54%	3,14	1,11	3,16	0,92
Interdisciplinary thematic work	37%	3,00	1,22	2,97	0,86
Homework	95%	1,95	1,05	2,99	1,01

Independent sample t-tests were run to determinate if there were any significant differences between the two clusters regarding their beliefs and attitudes towards the different working methods. There were significant differences between the clusters for *individual work*, *work in textbooks*, *joint review with the teacher*, *problem-solving*, *laboratory work*, *interdisciplinary thematic work* and *homework*.



The students in Cluster 1 regarded these working methods as both more enjoyable and instructive than the students in Cluster 2 (Appendix 2).

## Conclusion and Discussion

The results of this study confirm the tendency visible in national and international evaluations concerning Swedish students' attitudes towards mathematics education. Although a great deal of effort has been made at the national level to enhance students' interest in mathematics, the subject was not regarded as one of the most enjoyable at these two schools, and few students looked forward to their mathematics lessons. However, the students were satisfied with their current mathematics education and felt they got enough help in school. Receiving a grant for a mathematics project demands active mathematics teachers and positive school leaders who have the resources to formulate a vision of how they would like to develop the teaching (cf. Johansson, 2001). Hence, it is possible that the schools that take part in the mathematics initiative are not those that lack resources, although one of the schools in our study was under average concerning the proportion of students passing the subject of mathematics in the ninth grade. It is also possible that the teachers at the two schools have already placed higher demands on the quality of their instruction.

Regarding students' self-confidence, our study supports the results from National Evaluation (Skolverket, 2005) and recent TIMSS-studies, with 75% of the students considering themselves to be good at mathematics. Hence, in this case the goals of the Swedish steering documents seem to have been attained. Earlier research has shown positive correlation between students' self-perception and their achievement (e.g. Linnanmäki, 2004). Yet, the results in Sweden are getting worse. Could one possible explanation for this be that students are not provided enough challenges in mathematics in school? NU03 reported that more students (30%) find the mathematics tasks they are given too easy, compared to similar studies (17%) from 1992. Almost 60% of the students in our study considered most of the mathematics tasks they are given to be too easy. Confronting only easy tasks may make the students believe they are skilled in the subject. Good self-confidence and the experience of tasks as too easy correlated in our study. Research has pointed out that in effective mathematics teaching, students need to be given tasks that challenge them (cf. Hiebert & Grouws, 2007).

The hands-on activities that have been advocated in many in-service education projects by, for example, the National Center of Mathematics Education (NCM), and that have dominated many school projects seem to have led to lower expectations placed on students (Skolverket, 2011a). A new national

curriculum was implemented during the study, and it is too early to judge its effects concerning the compulsory school goals. Similar to the earlier Swedish curriculum (Lpo94), there is a heavy emphasis on everyday mathematics. Expectations on students concerning more abstract mathematics (for example, proof and proof-related items, which students have traditionally experienced as difficult) are low compared to those in Finland and Estonia (Hemmi, Lepik & Viholainen, submitted). Yet, teachers are given a great deal of freedom to choose relevant activities for students and even problems with every-day connections can be made more demanding. This is important for the teachers to consider when they go on designing their projects.

Our study shows that a majority of the working methods most commonly used in mathematics instruction are also those that the students found the least enjoyable. However, if we choose to look at how instructive the students consider these working methods the view is quite different, as the methods the students found most enjoyable were not always regarded as the most instructive. Many of the schools that received money from the government for local developmental projects in mathematics teaching stated that they wanted their students to experience mathematics as more enjoyable (Skolverket, 2011a). The question is whether this contributes to better mathematics teaching. Studies (e.g. Askew et al., 2010) have pointed out that even countries that display good results in mathematics have trouble with students' negative attitudes. Do all mathematics lessons have to be perceived as “fun”, or are there other aspects that can motivate students as well, for example higher-level challenges? In future research it might therefore be desirable not only to study how enjoyable students find different working methods. Other aspects such as “anxiety” and “challenging” may also be of importance.

Another question concerns students' beliefs about what learning mathematics means. We could argue that, although it is important to listen to students' opinions, it can be hard for them to evaluate their own learning. For example, the communication and shaping of mathematical discourse is stressed as important both in research (cf. Franke, 2007) and in the Swedish steering documents, but group work and work in pairs are not considered equally instructive as individual work by the students in our study. As shown by Boekaerts and Corno (2005), the learning goals a teacher has in mind are not always adopted by the students, which can make it hard for them to evaluate their own learning in relation to the goals. Nevertheless, it is important to consider students' opinions, since a negative attitude can make them reluctant in learning situations and cause them to avoid challenges (Granström & Samuelsson, 2007). As Franke (2007) asserts, it is the teacher's responsibility to foster “a discourse environment that both

supports students and helps to create, among them, new identities that include a favorable disposition towards mathematics” (p. 231). In that discussion, the aims of the mathematics teaching should be brought up to the surface so that teacher and students alike are all working towards the same goal.

Granström and Samuelsson (2007) show that students with already positive attitudes towards mathematics education prefer collective discussions over group work, but at the same time this working method reinforces the negative attitudes of students who already dislike mathematics. More research needs to be done in the field of “how classroom practices are negotiated so that they do not have differentially negative impacts on any particular group of students” (Franke, 2007, p. 237). Our study shows that students with more negative attitudes towards their mathematics education find many working methods both less enjoyable and instructive than students with more positive attitudes. These working methods include *individual work*, *work in textbooks* and *joint review with the teacher*, which are also the ones the students perceive to be most frequently used in their mathematics education. Different ways of working are found enjoyable and instructive by different students, and we have to be careful so that we do not teach in a way that has a negative impact on certain students.

Varying the methods and maintaining an open dialogue with students concerning their beliefs about and attitudes towards mathematics education could lead to an increasing number of students that both enjoy mathematics and achieve the goals. Therefore it will be interesting to see whether, and in that case how, this study’s students’ attitudes and beliefs will change after these two schools have completed their mathematics development projects.

## References

- Askew, M., Bretscher, N., Hodgen, J., & Hossain, S. (2010). *Values and Variables – Mathematics Education in High-performing Countries*. London: The Nuffield Foundation.
- Boekaerts, M., & Corno, L. (2005). Self-regulation in the classroom: A perspective on assessment and intervention. *Applied Psychology*, 54(2), 199–231.
- Butler, D. L., & Winne, P. H. (1995). Feedback and Self-Regulated Learning: A Theoretical Synthesis. *Review of Educational Research*, 65(3), 245–281.
- Cervin, M. K. (2011). *Attityder till matematik: En enkätundersökning av grundskoleelevers attityd till ämnet matematik. [A study of compulsory school students’ attitudes towards the subject of mathematics]*. Project work. Mälardalen University: Eskilstuna.

- Di Martino, P., & Zan, R. (2001). The problematic relationship between beliefs and attitudes. In *Proceedings of the MAVI-X European Workshop*, pp. 17-24. Kristianstad, Sweden.
- Di Martino, P., & Zan, R. (2011). Attitude towards mathematics: a bridge between beliefs and emotions. *ZDM Mathematics Education*, 43(4), 471-482.
- Franke, M. L., Kazemi, E., & Battey, D. (2007). Understanding Teaching and Classroom Practice in Mathematics. In F. K. Lester (Ed.), *Second Handbook of Research of Mathematics Teaching and Learning*. (pp. 225-256). Greenwich, CT: Information Age Publishers.
- Furinghetti, F., & Pehkonen, E. (2003). Rethinking Characterizations of Beliefs. In G. C., Leder, E. Pehkonen & G. Törner (Eds.), *Beliefs: A Hidden Variable in Mathematics Education*. (pp. 39-57). Secaucus, NJ: Kluwer Academic Publishers.
- Granström, K., & Samuelsson, J. (2007). Important prerequisites for students' mathematical achievement. *Journal of Theory and Practice in Education*, 3(2), 150-170.
- Hannula, M. S. (2002). Attitude towards mathematics: emotions, expectations and values. *Educational Studies in Mathematics*, 49(1), 25-46.
- Hemmi, K., Lepik, M., & Viholainen, A. (submitted). Analyzing proof-related competences in Estonian, Finnish and Swedish Mathematics curricula – Towards a framework of developmental proof.
- Hiebert, J. S., & Grouws, D. A. (2007). The Effects of Classroom Mathematics Teaching on Students' learning. In F. K. Lester (Ed.), *Second Handbook of Research of Mathematics Teaching and Learning*. (pp. 371-404). Greenwich, CT: Information Age Publishers.
- Johansson, M. (in press). The mathematics initiative: unequal access to educational improvement. *Proceedings of the Sixth Nordic Conference on Mathematics Education, NORMA 11, Iceland May 11th – 14th, 2011*.
- Kariuki, P., & Wilson, P. (2002). *The Effects of Motivation on At Risk High School Students in Math Performance*. Paper presented at the Annual Meeting of the Mid-South Educational Research Association (Chattanooga, TN, November 6-8, 2002). Available [2012-03-14] at <http://www.eric.ed.gov/PDFS/ED474447.pdf>.
- Linnanmäki, K. (2004). Matematikprestationer och självuppfattning. [Mathematics achievements and self-perception]. In A. Engström (Ed.). *Democracy and Participation – A Challenge for Special Needs Education in Mathematics*. (pp. 205-221). Örebro: Örebro University, Department of education.
- McLeod, D. B. (1992). Research on affect in mathematics education: A reconceptualization. In D. A. Grouws (Ed.), *Handbook of Research on*

- Mathematics Teaching and Learning*. (pp. 575-596). New York: Macmillan Publishing Company.
- Mullis, I. V. S., Martin, M. O., & Foy, P. (with Olson, J.F., Preuschoff, C. Erberber, E., Arora, A. & Galia, J.) (2008). *TIMSS 2007 International Mathematics Report*. Chestnut Hill, MA: TIMMS & PIRLS International Study Center, Lynch School of Education, Boston College.
- Neuman, J. (2011). *Vad tycker eleverna om matematiken? – En kvantitativ studie av högstadielärares attityder till matematik, arbetssätt, samt hur de skulle vilja förbättra undervisningen de får i ämnet. [What do students think about mathematics? – A quantitative study of lower secondary students' attitudes towards mathematics, teaching approach and how they would like to improve the instruction they receive in the subject]*. Project work. Mälardalen University: Eskilstuna.
- Skolverket (2003). *Lusten att lära – med fokus på matematik. [The desire to learn – with a focus on mathematics]*. Stockholm: Skolverket.
- Skolverket (2005). *Matematik. Ämnesrapport till rapport 251 (NU-03)*. Stockholm: Skolverket.
- Skolverket (2006). *Läroplan för det obligatoriska skolväsendet, förskoleklassen och fritidshemmet Lpo94. [Curriculum for compulsory school, pre-school class and youth recreation]*. Stockholm: Skolverket.
- Skolverket (2011a). *Laborativ matematik, konkretiserande undervisning och matematikverkstäder. En utvärdering av Matematiksatsningen. [Hands-on mathematics, concrete teaching and mathematics workshops. An evaluation of the Mathematics initiative]*. Rapport 366. Stockholm: Skolverket.
- Skolverket (2011b). *Läroplan för grundskolan, förskoleklassen och fritidshemmet 2011. [Curriculum for comprehensive school, pre-school class and youth recreation]*. Stockholm: Skolverket.

## Appendix 1

<i>Statement</i>		<i>Mean</i>	<i>Standard deviation</i>	<i>t-value</i>
Mathematics is one of the topics I like best in school	Cluster 1	2,50	0,88	12,76*
	Cluster 2	1,19	0,45	
	Total	2,17	0,98	
I look forward to mathematics lessons	Cluster 1	2,55	0,66	8,88*
	Cluster 2	1,56	0,55	
	Total	2,30	0,77	
I will have use for the mathematics I learn in school	Cluster 1	3,62	0,54	7,71*
	Cluster 2	2,79	0,81	
	Total	3,41	0,71	
Most of the tasks in mathematics are too easy for me	Cluster 1	2,69	0,76	1,46
	Cluster 2	2,49	0,86	
	Total	2,64	0,79	
I am satisfied with the mathematics teaching I receive today	Cluster 1	3,35	0,67	5,46*
	Cluster 2	2,67	0,84	
	Total	3,18	0,77	
In school I get enough help in mathematics	Cluster 1	3,49	0,56	7,61*
	Cluster 2	2,56	0,73	
	Total	3,26	0,73	
I am good at mathematics	Cluster 1	3,05	0,64	6,08*
	Cluster 2	2,14	0,92	
	Total	2,83	0,82	

*The two clusters responses to statements about attitudes towards mathematics education and beliefs about themselves as mathematics learners. Maximum value is 4 and minimum value is 1. Cluster 1 (n = 129) and Cluster 2 (n = 43). \*p <.001*

## Appendix 2

<i>Working method</i>		<i>N</i>	<i>Mean</i>	<i>Enjoyable</i>		<i>Instructive</i>		
				<i>SD</i>	<i>t-value</i>	<i>Mean</i>	<i>SD</i>	<i>t-value</i>
Individual work	Cluster 1	128	3,02	1,07	5,92*	3,91	0,82	3,12**
	Cluster 2	43	1,86	1,21		3,40	0,98	
	Total	171	2,73	1,21		3,78	0,89	
Work in pairs	Cluster 1	107	3,50	0,99	-0,33	3,38	0,84	0,18
	Cluster 2	32	3,56	1,11		3,34	1,18	
	Total	139	3,51	1,02		3,37	0,93	
Group work	Cluster 1	99	3,56	1,05	1,78	3,36	0,89	1,65
	Cluster 2	33	3,18	1,01		3,06	1,00	
	Total	132	3,46	1,05		3,29	0,92	
Work in textbooks	Cluster 1	125	2,93	1,12	6,12*	3,89	0,85	4,31*
	Cluster 2	43	1,74	1,00		3,21	0,99	
	Total	168	2,63	1,21		3,71	0,94	
Other material than textbooks	Cluster 1	96	4,24	0,93	0,75	3,52	0,91	0,83
	Cluster 2	31	4,10	0,94		3,35	1,14	
	Total	127	4,20	0,93		3,49	0,97	
Joint review with the teacher	Cluster 1	127	3,10	1,03	4,72*	3,98	0,97	4,36*
	Cluster 2	43	2,23	1,09		3,19	1,18	
	Total	170	2,88	1,11		3,78	1,08	
Problem-solving	Cluster 1	98	3,20	1,26	3,78*	3,48	0,96	3,67**
	Cluster 2	37	2,27	1,35		2,62	1,30	
	Total	135	2,95	1,35		3,24	1,12	
Laboratory work	Cluster 1	70	3,40	0,98	3,98*	3,37	0,82	3,73*
	Cluster 2	24	2,42	1,21		2,63	0,92	
	Total	94	3,15	1,13		3,18	0,90	
Interdisciplinary thematic work	Cluster 1	45	3,33	1,09	3,87*	3,16	0,74	2,77**
	Cluster 2	19	2,16	1,17		2,53	1,02	
	Total	64	2,98	1,23		2,97	0,87	

Homework	Cluster 1	123	2,09	1,00	5,46*	3,12	0,94	3,84*
	Cluster 2	40	1,27	0,75		2,45	1,01	
	Total	163	1,89	1,01		2,96	1,00	

*How enjoyable and instructive the two clusters find different working methods. Maximum value is 5 and minimum is 1. SD stands for standard deviation. \* $p < .001$ ; \*\* $p < .01$*





# **A good mathematics teacher and a good mathematics lesson from the perspective of Mexican high school students**

GUSTAVO MARTÍNEZ-SIERRA

gmartinezsierra@gmail.com  
National Polytechnic Institute. Mexico

## **Abstract**

*This article reports a qualitative investigation that identifies the characteristics of “good mathematics teaching” from the perspective of Mexican third-year high school students. For this purpose, the social representations of “a good mathematics teacher” and “a good mathematics lesson” were identified in a group of 67 students. In order to obtain information, an open-ended questionnaire was applied first and then focus groups with three or four students were organized. The answers to the questionnaire were analyzed by locating categories that consolidate a specific social representation. The information collected in the focus groups contributed to shedding light on the meaning of the words, phrases and notions of common sense knowledge used by the students.*

## **Keywords**

*social representations, high school students, good mathematics teaching, good mathematics teacher, good mathematics lesson*

## **Introduction**

There is currently a growing interest in international research in relation to understanding the views of students and teachers regarding mathematics lessons and the practices resulting from those views. This interest is based on the idea that classroom activity is a collaborative practice constructed with the participation of the teacher and the student, and cannot be split into teaching and learning.

Some of this research has been carried out to supplement research that has reported national norms and standards for student academic achievement and teaching practices in Australia, Germany, Japan and the US (Clarke, Keitel and Shimizu, 2006). This research is based on the hypothesis that the views and

practices of students must have the same priority as the ones from teachers. In this respect, Kaur indicates that:

*As learning is dependent upon the situations and circumstances in which it is engendered and the feelings these situations provoke in students, any attempt to improve mathematics teaching must take into account both teacher practice, student practice and their responses to each other's practice. (Kaur, 2008, p. 951)*

Research focused on students' and teachers' perspectives of mathematics lessons includes their meanings of "good teaching", "good teacher", "good class", "model class" or "effective teaching". (Kaur, 2008, 2009; Li, 2011; Ngai-Ying, 2007; Pang, 2009; Seah & Wong, 2012; Shimizu, 2006; Yoshinori, 2009; Perry, 2007; Cai and Wang, 2010). These research papers have reported differences and similarities in the thoughts of teachers and students from different school levels and countries. The international project "Learner's Perspective Study" (LPS) has focused significantly on analyzing lessons given by competent teachers, according to the cultural context of each country, instead of an average lesson. For LPS researchers, this decision appeals to what they think could be interesting for a teacher: not knowing about supposed average lessons for one or several countries, but being informed about what very competent teachers do in their lessons, in order to identify possible successful strategies for their own lessons (Clarke, Mesiti, Jablonka & Shimizu, 2006, p. 43).

Kaur (2008, 2009) carried out a series of studies in Singapore where 8th grade students were asked to describe the qualities of a "good mathematics lesson" and the "best mathematics teachers". In those different studies, she found that students consider that a mathematics lesson is good when any of the following teacher characteristics are present (Kaur, 2009, pp. 343-346): the teacher "explained clearly the concepts and steps of procedures", "made complex knowledge easily assimilated through demonstrations, use of manipulatives, real-life examples", "reviewed past knowledge and introduced new knowledge", "used student work/group presentations to give feedback to individuals or the whole class", "gave clear instructions, related to mathematical activities for in class and after class work", "provided interesting activities for students to work on individually or in small groups" and "provided sufficient practice tasks for preparation towards examinations". Descriptions by students of a good mathematics lesson include the teacher "moving from desk to desk" (Kaur, 2008, p. 960). Descriptions most frequently given of the best mathematics teachers were the following: "patient, understanding, caring/kind, good at mathematics, explains clearly, ensures students understand, and provides individual help". Kaur (2009, p. 346)

concluded that “good mathematics teaching in Singapore is student-focused but teacher-centered”.

Other studies (Shimizu, 2006, 2009; Kaur, 2008, 2009) have been interested in comparing the practices and perspectives of students and teachers. In Japan, for example, Shimizu (2006) found discrepancies between the perceptions of students and teachers in relation to mathematics lessons. He found that students identify significant events in lessons differently to the teachers; and when they agree on a significant event, they do so for different reasons. In Shimizu (2009, p. 315-316), it is reported that Japanese students in public junior high schools in Tokyo identify a good lesson when “understanding” or “thinking” occur (“I can understand the topics to be learned”, the students say) and when there is a “whole class discussion”. Shimizu (2009, p. 317) concludes “that a ‘good’ lesson is co-constructed classroom practices by the teacher and the students”.

In general, the research presented herein shows that the views of teachers and students regarding “good teaching”, a “good teacher”, a “good lesson”, a “model lesson”, or “effective teaching” vary in relation to multiple factors. Pang (2009) concludes, for example, “that good mathematics instruction may be perceived differently with regard to underlying social and cultural norms”. This is why various researchers have indicated the importance of carrying out comparative studies between different countries and social contexts. For example, the large international study reported in Clarke, Keitel & Shimizu (2006) is based on the hypothesis that:

*In the formulation of the Learner’s Perspective Study that there might be sets of actions and associated attitudes, beliefs, and knowledge of students that might constitute culturally-specific coherent learner practices. (Clarke, Keitel & Shimizu, 2006; p. 2)*

In Mexico and Latin America, there has been no research into the views of students and mathematics teachers in relation to what constitutes “good teaching”. This research aims to start filling that gap that void by answering the following research question:

- From the perspective of Mexican High School students, what is a “good mathematics teaching”?

There are many ways to carry out a conceptualization from the students and the teachers’ views. In this research, I have chosen to do this through *social representations*. A social representation is a stock of values, ideas, beliefs, and

practices that are shared among the members of groups and communities (Jodelet, 1986; Moscovici, 1976). I decided to ask the following research questions in this paper:

- What social representations does a group of high school students possess in relation to a “good mathematics teacher”?
- What social representations does a group of high school students possess in relation to a “good mathematics lesson”?

## Theoretical framework

The students’ and teachers’ perspectives of a good mathematics teaching can be analyzed from different theoretical framework. I chose social representations (Jodelet, 1986; Moscovici, 1976) because they are expressions of common sense knowledge (Berger and Luckmann, 1966). This choice emerge from the consideration that common sense knowledge is the most basic, primary, immediate knowledge of any individual as a member of a community, group or society, whose integration fundamentally depends on the existence of that knowledge. Common sense knowledge is the people’s certainty that phenomena are real and possess specific characteristics.

I assume reality as a social construction where people are social beings based on the reality in which they live but that also participate in the transformation of this reality. Although people create a particular vision of reality, this does not mean that it constitutes an individual process, instead its production is a social process that occurs in everyday life during interaction with others. According to Berger and Luckmann (1966), reality is an innate quality of the phenomena that we recognize as being independent of our own will; in other words we cannot make them disappear. Common sense knowledge is the knowledge that we construct during day-to-day relations, through models of thinking that we receive and transmit through tradition, education and communication, and which allows us to understand and explain facts and ideas that exist in our immediate world, since they provide us with a reference framework in order to know how to behave with other people.

Social representations establish a specific form of common sense knowledge, the specificity of which depends on the social nature of the process they produce. They include the set of beliefs, knowledge and opinions produced and shared by individuals in the same group in relation to a particular specific social object (Guimelli, 1999). A social representation is a guide for people’s action in front of a specific social object. Therefore, the study of social representations is particularly

important since the way in which they are produced and transformed helps to understand human behavior. The representation operates as a system for the interpretation of the reality that governs the relationships of individuals with their physical and social environment, due to the fact that it establishes their behaviors or their practices. Social representations are guide for actions and social relations. In Abric's opinion, social representations are a pre-decoding system of reality since it establishes a set of anticipations and expectations (Abric, 2004, p. 12).

In other words, social representation is practical knowledge. They give meaning, within incessant social movement, to events and activities that end up becoming commonplace to us and this knowledge forges evidence of our consensual reality, as it participates in the social construction of our reality (Jodelet, 1986, p. 473). Consequently, social representations are characterized by their significant, shared character, where their genesis is composed of the interactions and their functions fulfill practical purposes and they are thus a socially created and shared knowledge for practical purposes that takes part in the construction of a shared reality for a social group and their function is to create behaviors and communication between individuals. Social representations are "cognitive systems" in which it is possible to recognize the presence of stereotypes, opinions, beliefs, values and norms that usually have a positive or negative behavioral orientation" (Araya, 2001, p. 11).

According with Gorgorió & Abreu (2009, p. 64) the notion of social representation may be easily applied to mathematical practices or mathematical learning. People interpret what happens around them as mathematical when it fits their image of what counts as mathematics. Teachers categorize their students as good, bad, or indifferent based on their images of what is entailed in learning mathematics. The aim of this article is to explore the ways in which the notion of social representations can offer useful insights in understanding the students' and teachers' perspectives of a good mathematics teaching.

## Methodology

### Procedure

In order to obtain the data an open-ended questionnaire and focus group interviews were carried out. The purpose of these two techniques was to generate written and verbal discourse<sup>1</sup>, allowing us to find out the social representations.

---

<sup>1</sup> In this paper the word *discourse* is used in a very broad sense to refer to narratives generated by students through the instruments used in this research: narrative written to answer the open questions in the questionnaire and oral narrative through focus groups interviews.

The questionnaire was composed of open-ended questions to not limit the answers of the participants and to allow them to openly express their opinions, reducing the influence of the questionnaire to a minimum. Two questions were asked in order to discover the social representations of “good teaching”: 1) in your opinion, what characterizes a GOOD MATHEMATICS TEACHER? And 2) in your opinion, what characterizes a GOOD MATHEMATICS LESSON? In the questionnaire given to the students, the capital letters were used to emphasize the purpose of the representation of interest in each question. The questions asked in the focus group were the same as those in the questionnaire and the role of the interviewer was to ask for more specific information in relation to answers regarding the use and meaning of words or phrases used by the students. For this purpose, questions such as, in your opinion, what is a dynamic class?, why do you say that the lesson is boring?, what does it mean that a teacher knows how to explain?, etc.

Morgan (1996, p. 130) defines “the focus groups as a research technique that collects data through group interaction on a topic determined by the researcher”. This definition has three essential components. First, it clearly states that focus groups are a research method devoted to data collection. Second, it locates the interaction in a group discussion as the source of the data. Third, it acknowledges the researcher’s active role in creating the group discussion for data collection purposes. A focus group is a group of people who are asked about their perceptions, opinions, beliefs, and attitudes towards a product, service, concept, advertisement, idea, or packaging. Questions are asked in an interactive group setting where participants are free to talk with other group members. A focus group technique aims at the individuals selected by researchers to discuss and elaborate, based on their personal experience, on a social theme or fact subject to research. Focus groups is an appropriate method for data collection when one is interested in social representations because they are based on communication and it is the heart of the theory of social representations (Kitzinger, Markova & Kalampalikis, 2004).

Both, the questionnaires and the focus groups, were carried out after school in approximately hour and a half in a classroom, this allowed the students to gather at tables. We worked in sets of students with two interviewers, none of which were teachers of the students (two sets of twelve students, two sets of fifteen students and a set of thirteen students). The procedure were as follows: 1) Individual application of the questionnaire, 2) Creation of four focus groups of between three and four students as students themselves decided, 3) Collective answering the questionnaire in each focus group, 4) Commenting and providing

more specific information in relation to the answers with the interviewers. The second, third and fourth part were videotaped.

### Participants and context

The IPN (National Polytechnic Institute for its acronym in Spanish) is a public institution that provides free or very low cost studies in Mexico City, from high school to postgraduate level in the area of science and technology. The CECYT (Centre for Science and Technology Studies for its acronym in Spanish) are part of the education offered by high school level of IPN dedicated to the training of technicians. The participants were a non-statistical sample of 67 fifth-semester students, 16 to 18 years. It is important in focus group research that participants have some form of homogeneity. Therefore it was decided that the participants were students enrolled in the same school in the same math class with the same mathematics teacher.

### Data analysis

The general strategy for this analysis was a constant comparative method (Strauss, 1987; Glaser and Strauss, 1967), which permitted the categories to emerge from the data.

The data was analyzed using constant comparison method, as well as the grounded theory approach (Glaser and Strauss, 1967; Strauss & Corbin, 1990). The steps in the constant comparison method of analysis are: 1) Begin collecting data, 2) Look for key issues, recurrent events, or activities in the data that become categories for focus, 3) Collect more data that provide many incidents of the categories of focus with an eye to seeing the diversity of the dimensions under the categories, 4) Write about the categories that you are exploring, attempting to describe and account for all the incidents you have in your data while continually searching for new incidents, 5) Work with the data and emerging model to discover basic social processes and relationships, and 6) Engage in sampling, coding, and writing as the analysis focuses on the core categories. The encoding was performed by assigning a key sentence to each of the responses to the questionnaires or focus group interviews according to the main idea of each paragraph. Following the constant comparison method these codes were grouped into categories. Each category was interpreted as a social representation and was expressed through a minimal expression (Singéry, 2001); which is a phrase that represents the global meaning and condenses the form in which subjects capture the represented object: what this object is for them and their position in relation to that reconstruction. This global meaning is constructed by the researcher and is the result of the entire



content of the representation, the point of reference on the basis of which the set of dimensions and cognitions is organized.

The students were identified with the labels An (with n being from 1 to 67). The En label identified either of the two interviewers in the focus groups (one of the interviewers was the author of this paper). I used a diagonal line between two words to note that two words have the same meaning from the perspective of students. In addition to the above, square brackets were used when two phrases or a phrase and a word have the same meaning. Thus, for example, daily/everyday indicates that for students the adjectives 'daily' and 'everyday' are equivalent, and apply/[put into practice] indicates the same meaning between the word 'apply' and the phrase 'put into practice'. Such equivalency of meanings was identified in the focus groups.

The next sections show the social representations of a good mathematics teacher and the social representations of a good mathematic lesson that I identified in the analysis of data from the questionnaire and the focus groups. They also contain examples of student responses (provided in their responses to open-ended questionnaire). In the first social representation (*A good teacher has knowledge and knows how to [teach it]/[transmit it]/[explain it]*) I have also placed some examples of dialogues conducted in focus group interviews that allowed me the interpretation and subsequently built the categories identified as social representations.

## The social representations of a good mathematics teacher

A good teacher has knowledge and knows how to [teach it]/[transmit it]/  
[explain it]

*Someone who perfectly masters mathematics and is able to explain it easily to someone else (A47).*

*A teacher who knows how to express their knowledge clearly in front of the class (A7).*

*Someone who [...] has a command of the subject so that they can teach it well (A13).*

*Someone who gives you the knowledge in order to be able to solve exercises using a good method (A4)*

Students consider that mathematical knowledge is something that can be given/ passed on/taught to other people, so a good teacher is not only knowledgeable, but also has the ability to pass on that knowledge by explaining it.

*En: How can I understand mathematics? [The interviewer refers to collective response of the focus group that establishes 'that a good teacher is one who can make mathematics be understood and who leaves his students in no doubt at all']*

*A35: Being knowledgeable*

*A36: And being able to pass this knowledge on*

*A35: And the ability to pass on knowledge*

*En: What do you mean by 'pass on'?*

*A35: That students understand what the teacher is talking about, I mean, the subject that the teacher is talking about is explained in such a way that small children can understand it, and that if students do not understand it, it is necessary to find a new way of explaining it so that students understand.*

Explanations must vary according to the student or group. Students like being given alternative explanations if they think that the first or second given is inappropriate.

*A14: The teacher uses more suitable and easier ways of explaining.*

*En: So that it is easy for them to learn?*

*A15: Yes, if we don't understand using one method, it is necessary to use another one ...*

*A14: They should explain in another way*

A good teacher explains step by step and does not leave uncertainties

*Someone who knows how to explain something to you as many times as necessary, someone who is patient, who knows the subject and masters it (A3).*

*Someone who provides good examples and provides a detailed explanation of each case, someone who not only knows the subject you are going to study, but lots of subjects so that they can answer any question (A53).*

*Someone who provides a detailed explanation of every problem and answers questions clearly (A51).*

*Someone who does not leave uncertainties in the minds of their students (A11).*

#### A good teacher is patient/ comprehensive

*Someone you can talk to when you have a question about their lesson (A48)*

*Someone who is patient, accessible, understanding (A22).*

*Someone who gives their lessons in a patient, tolerant way, with an efficient level of preparation (A30).*

*Someone who teaches the lessons in a friendly way, with pleasure, with dedication. ... who masters the subject so that they can teach it well (A13)*

#### A good teacher does not make lessons tedious/boring and teaches in an easy/simple/clear way

*Someone who makes an effort so that students understand and doesn't make the lessons difficult (A50).*

*Someone who does not get tired of explaining and does so in a clear way so that the subjects do not seem so complicated (A52).*

*A teacher who does not get irritated and helps you, someone who explains the subjects to be taught with pears and apples [basic explanation for small children] (A43).*

#### A good teacher arouses interest in students

*Someone who arouses my interest to learn and to solve problems (A45).*

*Someone who teaches their lessons in such a way that students are interested (A38).*

*Someone who makes students interested in the subject, as well as allowing them to understand it (A35).*

## The social representations of a good mathematics lesson

A good lesson is dynamic / [is not boring] and you learn

*When a teachers manages to teach you something, without making it boring or monotonous (A22).*

*In which you are not bored and the knowledge you learn stays with you (A4).*

*When time goes quickly as, if that is the case, the class is not boring, which means that you are making an effort or you understand the subject being discussed (A50).*

In a good mathematics lesson, there are [good explanations]/ [step-by-step explanations]/ [you are not left with any uncertainties]

*A class in which there are no uncertainties at the end because all uncertainties were resolved during said class (A19).*

*When all uncertainties are clarified (A18).*

*When time is utilized to resolve all uncertainties with regard to the subject and the teacher provides support (A25).*

*When everything is understood and nothing is unclear at the end (A32)*

In a good mathematics lesson, there are lots of exercises and student participation

*A good explanation of the subject with examples explained by the teacher teaching the subject and exercises to answer, reviewing answers in order to see that we are doing them correctly (A3).*

*When the entire class is very attentive, solving exercises in relation to the subject and participating in the lesson (A15).*

*An interactive lesson where students solve exercises on the blackboard and the teacher corrects mistakes and resolves doubts that arise (A64).*

*A lesson that is enriched with exercises and lots of participation from my classmates (A1).*

## Conclusions

This paper studied the points of view of Mexican high school students in relation to good mathematics teaching, through the application of social representations as the theoretical and methodological principle. The results reported herein will allow us to better understand how students perceive life in the classroom, how they feel about their learning and their perceptions of how learning can be improved. This data may be useful in the current search to involve students and motivate them to study mathematics.

The conclusions of this study have similarities and differences with the conclusions of other studies that have examined what students consider a mathematics lesson to be and what makes a mathematics teacher good. One of the findings is that most students emphasize that good teaching has much to do with how the teacher explains things. A similar result has been found in other studies (Kaur, 2008, 2009; Shimizu, 2009; Murray, 2011). Students consider a good teacher to be someone with knowledge who knows how to transmit it, providing step-by-step explanations and leaving no uncertainties. This conceptualization is based on a metaphor of knowledge or the ability to solve problems as a material asset or possession that one person may pass on to another, by explaining, as if was an object or thing. For the students a good teacher is patient/comprehensive and does not make lesson tedious/boring, they teach in a simple and fun way and arouse interest in students. In a good mathematics lesson, you don't get bored and you learn. There are good, varied explanations and lots of exercises and student participation.

The social representations reported herein demonstrate the desires and expectations of students in relation to the teaching of mathematics. They also demonstrate the values that have been socially constructed in and around school. Values represent what students consider as the most appreciated and important aspects of mathematics. Values consist of everything that is subject to their preference or choice. This is why understanding the students' value in relation to mathematics teaching allows us to draw closer to mathematical well-being (Bishop, 2012). In particular, in the group of students whose representations are reported herein, I found that the desire of not being bored significantly predominates, which indicates a high level of dissatisfaction in the classroom experience. The fact that a limited number of students indicate that not being bored is based on a positive attitude on their part shows us that, for students,

the idea that mathematics classes are boring is part of their nature and can only be beaten with a good mathematics teacher capable of attracting their attention.

In my opinion, this research is a primary overview of the problem of good mathematics teaching from the perspective of Mexican high school students and teachers. In future research, I would recommend asking the opinion of teachers from Mexico and other Latin American countries in relation to the good teaching of mathematics and contrasting those opinions with the opinions of their students.

## References

- Abric, J. C. (1994). *Pratiques sociales et représentations* [Social practices and representations]. Paris, France: Presses Universitaires de France.
- Araya, S. (2002). *Las representaciones sociales: Ejes teóricos para su discusión*. [Social representations: Theoretical axes for its discussion]. San José: FLACSO.
- Berger, P. L., & Luckmann, T. (1966). *The Social Construction of Reality: A Treatise in the Sociology of Knowledge*. Garden City, NY: Anchor Books.
- Bishop, A. J. (2012). From culture to well-being: a partial story of values in mathematics education. *ZDM – the International Journal on Mathematics Education*, 44(1) 3-8.
- Cai, J., & Wang, T. (2010). Conceptions of effective mathematics teaching within a cultural context: perspectives of teachers from China and the United States. *Journal of Mathematics Teacher Education*, 13(3), 265–287.
- Clarke, D., Keitel, C., & Shimizu, Y. (2006). The learner's perspective study. In D. Clarke, C. Keitel & Y. Shimizu (Eds.), *Mathematics classrooms in twelve countries: The insider's perspective* (pp. 1–14). Rotterdam: Sense.
- Clarke, D., Mesiti, C., Jablonka, E., & Shimizu, Y. (2006). Addressing the Challenge of Legitimate International Comparisons: Lesson Structure in the USA, Germany and Japan. In D. Clarke, J. Emanuelsson, E. Jablonka & I. A. C. Mok (Eds.), *Making Connections. Comparing Mathematics Classrooms Around The World* (pp. 23-46). The Netherlands: Sense Publishers.
- Gorgorió, N., & Abreu, G. (2009). Social representations as mediators of practice in mathematics classrooms with immigrant students. *Educational Studies in Mathematics*, 72(1), 61–76. doi:10.1007/s10649-009-9183-3
- Glaser, B., & Strauss, A. (1967). *The discovery of grounded theory*. Chicago: Aldine.
- Guimelli, C. (1999). *La pensée sociale* [Social thought]. Paris, France: Presses Universitaires de France.
- Jodelet, D. (1986). La representación social: fenómenos, conceptos y teoría [Social representation: phenomena, concepts and theory]. In S. Moscovici (Ed.),

- Psicología social Vol. II. Pensamiento y vida social. Psicología social y problemas sociales* [Social Psychology Vol II. Thinking and social life. Social life and social problems]. Barcelona-Buenos Aires-México: Paidós.
- Kaur, B. (2008). Teaching and learning of mathematics: what really matters to teachers and students? *ZDM – The International Journal on Mathematics Education*, 40(6), 951-962.
- Kaur, B. (2009). Characteristics of good mathematics teaching in Singapore grade 8 classrooms: a juxtaposition of teachers' practice and students' perception. *ZDM – The International Journal on Mathematics Education*, 41(3), 333-347.
- Kitzinger, J., Markova, I., & Kalampalikis, N. (2004). Qu'est-ce que les focus groups? *Bulletin de Psychologie*, 57(3), 237-243.
- Li, Y. (2011). Elementary teachers' thinking about a good mathematics lesson. *International Journal of Science and Mathematics Education*, 9(4), 949-973.
- Ngai-Ying, W. (2007). Hong Kong teachers' views of effective mathematics teaching and learning. *ZDM – The International Journal on Mathematics Education*, 39(4), 301-314.
- Morgan, D. L. (1996). Focus Groups. *Annual Review of Sociology*, 22(1), 129–152. doi:10.1146/annurev.soc.22.1.129
- Moscovici, S. (1976). *La psychanalyse, son image et son public*. [The psychoanalysis, its image and its public]. Paris: PUF, 1961/1976.
- Murray, S. (2011). Secondary Students' Descriptions of "Good" Mathematics Teachers. *Australian Mathematics Teacher*, 67(4), 14-21.
- Pang, J. (2009). Good mathematics instruction in South Korea, *ZDM – The International Journal on Mathematics Education*, 41(3), 349-362.
- Perry, B. (2007). Australian teachers' views of effective mathematics teaching and learning. *ZDM—The International Journal on Mathematics Education*, 39(4), 271–286.
- Seah, W. T., & Wong, N. Y. (2012). What students value in effective mathematics learning: a 'Third Wave Project' research study. *ZDM – The International Journal on Mathematics Education*, 44(1), 33-43
- Shimizu, Y. (2006). Discrepancies in perceptions of mathematics lessons between the teacher and the students in a Japanese classroom. In D. Clarke, C. Keitel & Y. Shimizu (Eds.), *Mathematics classrooms in 12 countries: The insider's perspective* (pp. 183–194). Rotterdam, Sense Publishers.
- Shimizu, Y. (2009). Characterizing exemplary mathematics instruction in Japanese classrooms from the learner's perspective. *ZDM – The International Journal on Mathematics Education* 41:311–318.
- Singéry, J. (1994), Représentations sociales et projet de changement technologique en entreprise [Social representations and proposed technological change

in business]. In J.-C. Abric (Ed.). *Pratiques sociales et representations* (pp. 179-216) [Social practices and representations]. Paris, France: Presses Universitaires de France.

Strauss, A., & Corbin, J. (1990). *Basics of qualitative research: Grounded theory procedures and techniques*. Newbury Park – London – New Delhi: Sage.





## Alex's world of mathematics

HANNA VIITALA

hanna.l.viitala@uia.no  
University of Agder, Norway

### Abstract

*This is a story of a high achieving 15-year-old boy called Alex. The story is not about the achievement in class per se, but rather a story of what kind of role mathematics plays in his everyday life. High performance in school mathematics does not automatically mean thinking is flexible and performance reaches the same level outside school. However, this story shows how a boy, who does not value mathematics higher than any other school subject, can transfer the knowledge he has in mathematics outside the classroom quite naturally and spontaneously seek for valid examples from school mathematics when talking about mathematics in general.*

### Keywords

*affect, mathematical thinking, case study*

### Introduction

This paper derives from a research project on Finnish 15-year-pupils' mathematical thinking which aims to describe pupil's mathematical thinking in two perspectives; On one hand the aim is to find out if it is possible to combine results on mathematical thinking in different domains in mathematics (e.g. problem solving, algebra, and statistics), and on other hand combine results from cognitive and affective data.

When studying pupils' mathematical thinking, research has usually concentrated purely on the cognitive aspect. However, it has become clear that if we really want to describe mathematical thinking, we should also relate to affective factors (Vinner 2004). Nowadays “[a]rguably the most important problem for research on affect in mathematics is the understanding of the interrelationship between affect and cognition” (Zan, Brown, Evans & Hannula 2006).

The present paper concentrates on the affective data but not forgetting the cognitive aspects of learning mathematics. It discusses one case, a Finnish 15-year-old Alex, and aims to see what his own explanations reveal about his affect in mathematics, what role mathematics plays in his everyday life, and what he can say about his own mathematical thinking. This is an initial step in the research project to understand how Alex's 'interrelationship between affect and cognition' works.

## Theoretical framework

There are many studies on affect in mathematics in Finland. Some reviews have already been published about the subject (e.g. Hannula 2007; Viitala, Grevholm & Nygaard 2011). The short literature review below about studies on affect concentrates on the findings from Finnish lower secondary school. This is the level where Alex is at the time of the data collection.

The core of pupils' view of mathematics in grade 8 has been found to be constituted by four components: ability, difficulty of mathematics, success, and enjoyment of mathematics (Hannula & Laakso 2011). Similar results have also been found among different age groups (e.g. Rösken, Hannula & Pehkonen 2011). Positive dimensions correlated positively to other positive correlations, and negative dimensions correlated to negative views. The grade 8 pupils are "more clearly divided into those with a positive view of mathematics and to those who hold a negative view of mathematics" (Hannula et al. 2011, p.13).

The most recent national report on the Finnish learning results at the end on comprehensive school wonders if the calculation skills in Finland are declining (Hirvonen 2012). Together with mathematics assignments, a background survey including information about attitudes towards mathematics was collected. The results show how pupils "considered mathematics to be useful, but they did not like it at all that much" (ibid., p.12). Pupils' perceptions of their own skills were slightly positive. Gender differences were found to be minor.

Some affective data has also been collected in PISA assessments. The results show that Finnish pupils lack interest and enjoyment in mathematics. Only the pupils on the two highest proficiency levels seemed to be interested in and enjoy mathematics. Anxiety in mathematics was below OECD average and boys had more positive attitudes towards mathematics than girls. (Törnroos, Ingemansson, Pettersson & Kupari 2006) Finnish pupils were also characterized by

*“below average self-efficacy and low level of control strategies used. [...] In Finland affect was an important predictor of achievement. Mathematical self-concept was the strongest predictor of mathematics performance, and this correlation was strongest among countries in the study.” (Hannula 2007, p. 201)*

Theoretical framework around affect, its concepts and their connections have been used in very diverse way both in Finnish and international research (see e.g. Hannula 2007, Zan et al. 2006, Furinghetti & Pehkonen 2002, and MAVI proceedings throughout the years). Thus, some clarification is needed here also.

In the present paper affect and its different components such as beliefs, attitudes (McLeod 1994) and values (DeBellis & Goldin 1997) are not separated from each other. Instead, affective factors are seen as mixtures of motivational, emotional and cognitive processes (Hannula 2004). Moreover, affect is viewed through a model of the individual's self-regulative system, where cognition and emotion are viewed as representational systems which require motivation as an energizing system (ibid.).

When talking about affective data collected as part of a project on mathematical thinking it is also important to explain the tight connection between mathematical thinking and affect. This connection is well articulated by Hannula (ibid., p. 55):

*In mathematical thinking, the motivational aspect determinates goals in a situation. [...] Emotions are an evaluation of the subjective progress towards goals and obstacles on the way. [...] Cognition is a non-evaluative information process that interprets the situation, explores possible actions, estimates expected consequences, and controls actions.*

## Methods

The aim in this paper is to discuss one case, a Finnish 15-year-old Alex, and see what his own explanations reveal about his affect in mathematics, what role mathematics plays in his everyday life, and what he can say about his own mathematical thinking. This aim is reached by analysing video data from three semi-structured and focused interviews (Kvale & Brinkmann 2009) I had with Alex in the autumn 2010.

The interviews followed six themes. Four of them followed Pehkonen's categorization of mathematics related beliefs on 1) mathematics, 2) mathematics learning, 3) mathematics teaching and 4) oneself within mathematics (Pehkonen

1995, discussed also in Op't Eynde et al. 2002). Pupil's background and mathematical thinking were the two remaining themes. In the interviews pupil's own lines of thoughts were emphasized and followed whenever possible. A more elaborated structure of the interviews together with some example questions can be found in Table 1.

*Table 1. Interview themes and example questions.*

<i>Interview</i>	<i>Theme</i>	<i>Example questions</i>
1	Background	Tell me about your family.
	Mathematics	What is mathematics as science? Does it exist outside school? (How? Where?)
	Oneself within mathematics	Is mathematics important to you? Does it help you think logically? (How?)
2	Mathematics learning	How do you learn mathematics? Is it most important to get a correct answer?
3	Mathematics teaching	Does teaching matter to your learning? (How?) What is good teaching?
	Mathematical thinking	What does mathematical thinking mean? How do you recognize it?

The themes of the interviews also guided the data analysis and reporting of the results. In addition, data about learning mathematics was further analysed using Hannula's (2004) self-regulation system introduced above. The videotapes were first transcribed and categorized roughly into the six themes (in Finnish). In this process also some data reductions were done (shortening of sentences and leaving some parts of longer examples outside the transcription). Then the data was translated into English.

After having the original transcriptions in both languages, more data reduction was done following strictly the six themes introduced above. Throughout the analysis the words used by the interviewee were preserved. Only in the very end the key findings were put together and interpreted as is seen in this report, still offering some original data from the interviews to support the interpretations.

## Results

The categorization of the results follows the structure of the interviews (see Table 1) emphasizing the part of mathematics learning (which most reveals the relationship of affect and mathematical thinking). The chapter about mathematics learning also follows (loosely) Hannula's model of self-regulation (2004). The categorization is not exclusive; many of the findings could belong to different categories.

### Background

Alex is in his final grade in Finnish comprehensive school starting his 9th year of schooling. He is the only child with parents who both have higher level university degrees. Alex spends a lot of time doing sports, and mathematics is his third favourite subject in school after sports and English language. His mathematics grade<sup>1</sup> is 10 and it describes his skills in mathematics well because, in his own words, "I usually know the mathematics taught in school quite thoroughly." After comprehensive school he will go to upper secondary school.

### Mathematics

Alex's view of mathematics is rather dynamic: For instance, he emphasizes that, rather than changed, mathematics has expanded during the 9 years in school. As an example of this expansion he explains how "many different calculations can be calculated in different ways still getting a correct answer." He also sees mathematics strongly as a tool: as a science mathematics is "explaining different problems or natural phenomena, or such, with the assistance of calculations." Mathematics is important as a school subject because "it is very useful in school subjects such as physics, chemistry, and other natural sciences."

When asked about his use of mathematics outside school, he finds situations (dealing with money: gas for the moped, other expenses, earnings) where "simpler" mathematics is needed, and he finds examples of the mathematics he needs (calculations with percentages) or does not need "much" (geometry) or apply "yet" (systems of two equations, subject they were learning in class at the time of the interview). He also recognizes that in working life mathematics is needed "in quite many jobs."

---

<sup>1</sup> The scale in Finland is 4...10 where 10 is the best possible grade.

## Oneself within mathematics

Alex's affect in mathematics is very positive. He has a lot of self-confidence and he trusts himself "pretty much" in mathematics. He values mathematics and thinks that mathematics is important "as a school subject," and he sees that this view is also shared by his family and friends. The majority of the feelings he connects with mathematics are positive, he enjoys challenges in mathematics and he is persistence to find answers to his questions.

*"When you learn, [learning mathematics] is fun and interesting" whereas "calculating basic calculations, that are being calculated a hundred times, is a bit boring. However, then the routine is found so it [learnt mathematics] can be done also later on." Learning mathematics "might be exiting if it has something to do with oneself."*

*"With those [tasks] that I really have to think and I discover something [mathematics] is definitely not boring, they [the tasks] are very interesting."*

*Mathematics "is usually quite easy but challenges can, of course, be found and [mathematics] can be hard if it goes far enough." If mathematics feels hard "I think about it quite much [...] why [something is done, ..., and] it keeps bothering me. [..., I do want to find answers because] then it would not bother me anymore."*

Alex's motivation to study mathematics is twofold: he studies mathematics "for a good grade which also benefits future studies, and also for learning and understanding" mathematics. From these, the first (external) motivation seems to be dominating over the second (internal) one: Despite the very positive affect in mathematics, Alex sees that mathematics "is not more special than other [school subjects]" and he would not study mathematics (at home) if it were not compulsory. Nonetheless, it is clear that he recognizes the value of learning mathematics.

## Mathematics learning

Alex is very aware of his learning in mathematics and he can explain it in two levels: the overall process of learning and connecting new knowledge to prior knowledge. The overall learning process ("understanding what is being pursued" and "calculating tasks from easier to more difficult") is important to Alex because "without learning process one cannot discover everything" (that needs

to be learnt). Routine (even though boring) is also important so the calculations wouldn't feel difficult.

After the more general discussion of learning the discussion moved to learning new things and making connections in particular. This small part of one interview presented below gives a good example about Alex's awareness of his learning and net of knowledge, and how he does not always even realize making the connections:

*Int: (When you learn new things) do you for example search for connections to mathematics that has been learnt before?*

*Alex: Yes, I seek for connections to mathematics learnt before, I look for similarities. For example last year we had polynomial calculations, and now drawing lines and solving equations. They have quite a lot of the same things.*

*Int: So you remember similar things and you connect them to each other when you learn new things?*

*Alex: Yes, I don't necessarily always realise them if they are in different places, sometimes I do realize them, and sometimes they are self-evident and I don't think about them.*

Learning mathematics for Alex is more understanding than remembering and memorizing. Understanding means two things: First one has to understand why something is done (e.g. in polynomial calculations "understanding for example why the terms are moved to another side"). Secondly, one has to know another way to verify the solution than the one used in the task.

The emotions connected to learning mathematics are mostly positive as described before. Alex thinks learning mathematics is "fun and interesting," whereas rote learning is boring. He has a lot of self-confidence and trusts more his own reasoning than his calculations. Making mistakes does not frighten him, but when he does them, they disturb his thinking (he thinks it is hard to find the error). Mathematics "is usually quite easy but challenges can, of course, be found and it can be hard if it goes far enough."

Alex is motivated to learn mathematics and he aims for understanding. He also recognizes that he is responsible of his own learning. To know if mathematical knowledge is correct "one has to calculate or discover it oneself." Having a good grade in mathematics is the most important motivation for Alex to study



mathematics. Hence, he prepares for mathematics tests carefully and usually knows what kind of tasks there should be in the test. In addition, it tests, he checks his answers carefully: First he checks the units, next estimates if the answer is reasonable (if the magnitude of the answer is correct), then he rethinks the expression or equation and how he got it, and finally checks if the answer is correct.

### Mathematics teaching

Teaching is central to Alex's learning. "[He would] not study mathematics alone at home if it was not compulsory. [He learns] in school when [mathematics] is taught. Usually it is enough and [he does] not have to study it separately for tests at home." Teaching mathematics in school proceeds from details to wider connections. First calculating and solving equations is learnt, and then it is expanded and applied.

Good mathematics teaching is "illustrative: [learnt mathematics] is connected to 'somewhere it is really needed', and [explanations are also given on] what kind of phenomena can be transformed into calculations being learnt. [However, making connections] are many times hard in the beginning when calculating is rehearsed mechanically."

### Mathematical thinking

When explaining mathematical thinking, Alex brings up the same tool aspect as when describing mathematics as a science: For Alex mathematical thinking means "transforming different attributes, and for example weather conditions and natural phenomena into some form of calculations," or vice versa, he recognizes his mathematical thinking when "some form of calculating, or using or applying rules of natural sciences, applying things" exists.

Alex likes things to be logical: He likes Swedish and German languages least as school subjects as they are "not that logical and have a lot of exceptions." Mathematics helps Alex to think logically "as things can be made to numbers."

As an example of Alex's clear and prompt mathematical thinking here is a problem I gave him to solve in connection to discussion about having many answers to one problem. It is a modified PISA-task (originally 2 and 5 km): *Mary lives 3 kilometres from school, Martin 5. How far do Mary and Martin live from each other?* (OECD 2009, p. 111) *This is how Alex solved it without using any concrete tools to help him:*

*Alex: When thought quickly, 2 if you calculate the difference, but of course it can be 8 kilometres or something in between.*

*Int: Can it be anything in between?*

*Alex: [Pause] Almost, yes.*

*Int: Why?*

*Alex: Because they go by radius' from school. And apparently it forms circles for both and they can be to any ratio to each other. So, it becomes anything in between.*

## Conclusion and Discussion

This paper aims to discuss one case, a Finnish 15-year-old Alex, and see what his own explanations reveal about his affect in mathematics, what role mathematics plays in his everyday life, and what he can say about his own mathematical thinking. In this part of the paper the results presented above are discussed. Also some results from other data are brought up as part of the discussion.

Alex's affect in mathematics is very positive. He enjoys learning mathematics and is motivated to study it. Even though he considers mathematics important as one of the school subjects and seems not that interested in mathematics outside school, he understands the value of learning mathematics and works towards learning it in a very thorough way. Mathematics has strongly a tool value for Alex both as a science and as part of his everyday life.

Alex is very aware of his own mathematical thinking. This emerges most when discussing about his learning of mathematics. He is aware of his own learning process (understanding the goal in learning something, calculating tasks from easier to more difficult and finding routine). He can also explain well more detailed parts of learning new things, (e.g.) seeking similarities between the new thing and things learnt before. At the same time he explains teaching to be central to his learning and it seems (from the results presented here and the observations on the teaching in Alex's class) the teaching is supporting his way of learning new things and developing his mathematical thinking.

Alex seems to have a clear and organized (mathematical) thinking and net of knowledge. He can express himself in a very clear way when answering questions, is able to give spontaneous examples from school mathematics to

explain his thinking, and needs (at least in some occasions) just one stimuli to connect different topics in mathematics (in this paper polynomial calculations, equations and drawing lines) to each other. Also Alex's view on mathematical thinking seems broader than just thinking mathematics as calculations within mathematics; he also connects mathematical thinking to natural phenomena and natural sciences.

In connection to previous results on affect in Finland among Alex's age group, Alex is not a very exceptional pupil. He feels able to do mathematics, he enjoys it, succeeds in it and does not find it that difficult (cf. Hannula et al. 2011). In addition, he clearly thinks mathematics is useful, at least within natural sciences, and he likes mathematics as a school subject. The latter point contradicts previous results (Hirvonen 2012) but coincides with PISA results where the top pupils in Finland seem to be interested in and enjoy mathematics (Törnroos et al. 2006). (Whether Alex actually is part of the top two PISA groups, has not been studied.)

What makes Alex interesting is his high ability to explain his own thinking and the awareness of his own learning. He enjoys doing mathematics but it is not enough to carry the interest outside the classroom. He seems to be very down to earth with his abilities in mathematics and he recognizes that his mastery of mathematics is limited to school mathematics. It seems that it is possible to have highly positive affect in mathematics in school without being that interested in it in everyday life.

## References

- DeBellis, V. A., & Goldin, G. A. (1997). The affective domain in mathematical problem-solving. In E. Pehkonen (Ed.), *Proceedings of the 21st Conference of the International Group for the Psychology of Mathematics Education* (Vol 2, pp. 209-216). Lahti, Finland: PME.
- Furinghetti, F., & Pehkonen, E. (2002). Rethinking characterizations of beliefs. In G. C. Leder, E. Pehkonen & G. Törner (Eds.), *Beliefs: A Hidden Variable in Mathematics Education* (pp. 39-57). Dordrecht, the Netherlands: Kluwer Academic Publishers.
- Hannula, M. S., & Laakso, J. (2011). The structure of mathematics related beliefs, attitudes and motivation among Finnish grade 4 and grade 8 students. In B. Ubuz (Ed.), *Proceedings of the 35th Conference of the International Group for the Psychology of Mathematics Education* (Vol 3, pp. 9-16). Ankara, Turkey: PME.
- Hannula, M. S. (2007). Finnish research on affect in mathematics: blended theories, mixed methods and some findings. *ZDM*, 39(3), 197-203.

- Hannula, M. S. (2004). Affect in mathematical thinking and learning. Acta Universitatis Turkuensis B 273. Turku, Finland: University of Turku.
- Hirvonen, K. (2012). *Onko Laskutaito Laskussa? Matematiikan Oppimistulokset Peruskoulun Päättövaiheessa 2011*. (Are Skills to Calculate Declining? Learning Results in Mathematics at the End of Comprehensive School 2011). Tampere, Finland: Juvenes Print.
- Kvale, S., & Brinkmann, S. (2009). *InterViews*, (2nd ed.) London: Sage.
- McLeod, D. B. (1994). Research on affect and mathematics learning in the JRME: 1970 to the present. *Journal for Research in Mathematics Education*, 25(6), 637-647.
- OECD (2009). PISA 2009 Assessment Framework. <http://www.oecd.org/dataoecd/11/40/44455820.pdf> (3.5.2012)
- Op't Eynde, P., de Corte, E., & Verschaffel, L. (2002). Framing students' mathematics-related beliefs. In G. C. Leder, E. Pehkonen & G. Törner (Eds.), *Beliefs: A Hidden Variable in Mathematics Education* (pp. 13-37). Dordrecht, The Netherlands: Kluwer Academic Publishers.
- Pehkonen, E. (1995). *Pupils' view of mathematics: Initial report for an international comparison project*. University of Helsinki, Department of teacher education. Research Report 152.
- Rösken, B., Hannula, M. S., & Pehkonen, E. (2011). Dimensions of students' views of themselves as learners of mathematics. *ZDM*, 43(4), 497-506.
- Törnroos, J., Ingemansson, I., Pettersson, A., & Kupari, P. (2006). Affective factors and their relation to the mathematical literacy performance of students in the Nordic countries. In J. Mejding & A. Roe (Eds.), *Northern Lights on PISA 2003 - A Reflection from the Nordic Countries* (pp. 87-100). Copenhagen: Nordic Council of Ministers.
- Viitala, H., Grevholm, B., & Nygaard, O. (2011). About affect in five Finnish dissertations on mathematical thinking. In K. Kislenko (Ed.), *Current State of Research on Mathematical Beliefs XVI: Proceedings of the MAVI-16 Conference, June 26-29, 2010, in Tallinn, Estonia* (pp. 313-330). Tallinn, Estonia: Tallinn University.
- Vinner, S. (2004). Mathematical thinking, values and theoretical framework. In M. J. Høines & A. B. Fuglestad (Eds.), *Proceedings of the 28th Conference of the International Group for the Psychology of Mathematics Education* (Vol 1, pp. 126-127). Bergen, Norway: Bergen university college.
- Zan, R., Brown, L., Evans, J., & Hannula, M. S. (2006). Affect in mathematics education: An introduction. *Educational Studies in Mathematics*, 63(2), 113-121.



# Development of attitudes towards statistics questionnaire for middle school students and 8<sup>th</sup> grade students' attitudes towards statistics

AYŞE YOLCU<sup>1</sup> AND ÇİĞDEM HASER<sup>2</sup>

ayseyolcu@hacettepe.edu.tr

<sup>1</sup> Hacettepe University, Turkey

<sup>2</sup> Middle East Technical University, Turkey

## Abstract

*The purpose of this study was two-fold: to develop a valid and reliable instrument for examining middle grades students' attitudes towards statistics and to investigate 8<sup>th</sup> grade Turkish students' attitudes towards statistics. Attitudes towards Statistics Questionnaire (ATSQ) was developed for the study and piloted with 272 8<sup>th</sup> grade Turkish students. The factor analysis of ATSQ showed that the scale was unidimensional with .94 reliability coefficient. Then, 1034 8<sup>th</sup> grade Turkish students were surveyed through ATSQ. Results showed that their attitudes towards statistics were tentatively ranged between neutral to positive. Possible reasons of results and educational implications are discussed.*

## Keywords

*attitudes, statistics, questionnaire, middle school, students*

## Introduction

Attitudes towards statistics constitute an important part of statistics education, since attitudes have been regarded as a factor affecting statistical achievement, literacy, and reasoning (Gal, 2004; Watson, 2006). Attitudes are taken into consideration specifically for critical evaluation of statistical claims. For example, Gal (2004) states that certain beliefs and attitudes are an important part of statistics instruction as they are required in order to critically evaluate statistical messages. Attitudes also have an important role in the teaching and learning process during class time, the statistical behavior out of the class, and the enrolment in further statistics related courses. Students' attitudes towards statistics can help or hinder statistical thinking and they do influence the utilization of knowledge and skills in a variety of contexts (Gal, Ginsburg, & Schau, 1997). Students with negative attitudes towards statistics perform low in statistical literacy (Watson, 2006).

Attitudes towards statistics have generally been measured through Student Attitudes towards Statistics (SATS) (Schau, 2003) and Attitudes towards Statistics (ATS) (Wise, 1985) scales. However, studies using these instruments were limited to undergraduate or graduate students due to the nature of the items in these scales, which required respondents to be at a certain age group. Previous instruments developed for middle school students have focused on attitudes towards specific aspects of statistics such as graphing (Yingkang & Yoong, 2007) or merely on statistical literacy (Carmichael, 2010). Development of a valid and reliable instrument for examining middle school students' attitudes towards statistics is essential since they play an important role for the learning of statistics and the findings for the case of middle school students are scarce due to the limited number of useful instruments developed to date. Therefore, this study aims to develop a valid and reliable instrument for investigating Turkish middle school students' attitudes towards statistics. Following the construction and validation of such an instrument, this study also aims at investigating 8<sup>th</sup> grade students' attitudes towards statistics.

## Attitudes Towards Statistics

Individuals should have certain knowledge of statistics in order to contribute in an informed way to the debates including both statistical messages and wider social context such as politics, health, and education related issues (Carmichael, 2010). Statistics and probability concepts are closely related to individuals' daily lives and they contribute to the development of critical thinking about data and ability to make judgment based on data, which are essential skills for becoming informed citizens (NCTM, 2000). Acknowledging the importance of statistics in daily lives of individuals, elementary mathematics curriculum revisions in Turkey have addressed "Statistics and Probability" as one of the five major content areas of the Elementary Mathematics Education Curriculum (MoNE, 2005). Statistics and probability domain of the school mathematics curriculum consists of concepts such as sampling, measure of central tendency, graphs and tables, measure of spread, probability, and introductory inference (MoNE, 2005). Objectives regarding statistics and probability in Elementary Mathematics Education Curriculum in Turkey aim to develop informed citizens who possess knowledge of statistical concepts and who have appreciation of the importance of statistics in society. Appropriate interpretation, conjecturing, and predicting based on data are addressed in the curriculum and the affective issues such as building positive attitudes towards statistics and probability are also emphasized (MoNE, 2005). Yet, little is known about middle school students' attitudes towards statistics and there is not an instrument for quantitative analysis of these attitudes.

Attitudes towards statistics are addressed as important to investigate; however, there is no exact definition of this construct. Indeed, researchers have often defined attitudes in relation to what their assessment instruments measured (Gal, et al., 1997). For example, according to Schau (2003), who conceptualized attitudes towards statistics based on expectancy value model for achievement (Eccles et al., 1983 as cited in Schau, 2003), the components of attitudes towards statistics included students' attitudes towards capability of doing statistics, students' opinions and thoughts about the difficulty of statistics, and about the value of doing statistics successfully. Therefore, Student Attitudes towards Statistics (SATS) questionnaire developed by Schau and her colleagues (1995) consisted of affect, difficulty, value, and cognitive competence subscales.

In another study, Gal, Ginsburg, and Schau (1997) employed McLeod's (1992) definition for attitudes towards mathematics and considered attitudes towards statistics as the emotions and feelings including positive and negative responses experienced by individuals during learning statistics. For the purposes of the current study, this definition was extended with the inclusion of opinions and thoughts regarding statistics since attitudes can be seen as manners of acting, feeling or thinking that show a person's disposition or opinion towards a topic (Philipp, 2007). In the context of this study, attitudes towards statistics were defined as students' opinions and thoughts about statistics addressing the cognitive demand and value of statistics, together with emotions and feelings about statistics such as fear and enjoyment experienced by students while learning statistics.

The review of literature related to attitudes towards statistics pointed out that research within middle school contexts is scarce. Available findings indicated that middle school students' attitudes towards statistics varied between neutral and positive (Calderia & Mouriño, 2010). The results of intervention studies which investigated the effect of a teaching method on attitudes towards statistics were ambiguous since either attitudes remained the same around neutral (Yılmaz, 2006) or changed in a positive way (Cobb & Hodge, 2002). The change in the positive direction addressed the effect of constructivist climate in the classroom on middle school students' attitudes towards statistics which was defined as positive orientations about statistics (Cobb & Hodge, 2002). Considering that the findings are limited to the small number of available studies, the present study will contribute to the research on middle school students' attitudes towards statistics by examining 8<sup>th</sup> grade students' attitudes towards statistics through ATSQ.



## The Pilot Study

### Participants

The pilot study was conducted in classrooms of conveniently accessed teachers at public schools in three cities in Turkey. The participants of the pilot study were the students of these teachers. The demographic information sheet and ATSQ were administered to 272 8<sup>th</sup> grade students by their mathematics teachers within 20 minutes in their classrooms. Nearly half of the participants were female (52%) and the other half were male (48%). In addition, the mean of their latest mathematics grade was 3.6 out of 5.

### Instrument

ATSQ was modified by the researchers of this study from the Probability Attitude Scale (PAS) developed by Bulut (1994) to investigate the effects of different teaching methods on 8<sup>th</sup> grade students' attitudes towards probability. The PAS was modified in this study to address attitudes towards statistics due to "natural connections between statistics concepts and probability concepts" (Shaughnessy, 2007, p.958). The other rationale for modifying this instrument was that it was constructed for 8th grade students which confirmed to a great extent that the items in the questionnaire were appropriate for 8th grade students, who were at the age of fourteen, in terms of language, feelings and emotions. Additionally, since this scale was developed, piloted, and implemented in a Turkish context, the contextual factors during the modification were less of a concern.

PAS was originally composed of 28 items on a six point Likert scale with response options from Strongly Disagree to Strongly Agree. The item bank for PAS was derived from existing attitudinal instruments in the field of mathematics education, interviews with students and observations of students' attitudes towards probability. A total of 28 statements (15 positive and 13 negative items) were selected from this item bank and constituted the PAS. According to the factor solution of the scale, it was considered as unidimensional and describing general attitudes towards probability. The reliability coefficient Cronbach's alpha was calculated as .94 for PAS by Bulut (1994).

Modification of PAS was made through replacing the word "probability" by the word "statistics". The final form of ATSQ was reviewed by three mathematics education researchers and two mathematics teachers for clarity and the comprehensibility of items by providing them with the definition of attitudes utilized for this study. Whilst all the 28 items from the PAS remained on the

ATSQ, five-point scale was utilized instead of six-point scale in order to allow neutral responses. The items in the final form of the questionnaire are given in Table 2. “R” addresses reversed items.

## Analysis

In order to reduce the number of observed variables, exploratory factor analysis was conducted with the aim of grouping the variables in constructs. Factor analysis was run to determine which sets of observed variables sharing common variance characteristics defined the constructs. Principal components analysis with Varimax rotation method was carried out for ATSQ by PASW 18 statistical software. The exploratory factor analysis, including 28 observed variables, was considered in order to understand the underlying structure of this questionnaire.

Descriptive statistics for the items in the questionnaire indicated that there were a maximum of 9 missing values per item which constituted less than 5% of the total data. Hence, replacing missing scores with mean method was utilized in order to deal with missing data (Tabachnick & Fidell, 2007). At the end, there were 272 cases for pilot study of ATSQ which indicated that the sample size assumption were assured since there were approximately at least 10 cases for each variable (Tabachnick & Fidell, 2007).

The KMO measure revealed a value greater than 0.60 which indicated that evaluating the distribution of values was adequate for conducting factor analysis. In addition to this, the Bartlett’s Test of Sphericity was statistically significant ( $\chi^2= 3851.120$  and  $p=.000$ ) which indicated that the factor analysis could be conducted.

In order to determine the smallest number of factors that represented the interrelations between variables, Kaiser’s criterion, total variance explained the scale, and scree plot were examined. In Kaiser’s criterion method, only factors with eigenvalues greater than 1 were retained for further investigation.

According to eigenvalues, there were four underlying factors among variables whose eigenvalues were greater than 1, as given in Table 1 below. These four components explained a total of 57.96 per cent of the variance. However, Büyüköztürk (2011) stated that 30 per cent or higher are regarded as adequate variance explained when the scales have one factor. Since 42 per cent of variance was explained by the first component, ATSQ was determined to have single factor.

*Table 1. Initial Eigenvalues and Total Variance Explained by the First Four Principal Components.*

<i>Component</i>	<i>Initial Eigenvalues</i>		
	<i>Total</i>	<i>% of Variance</i>	<i>Cumulative %</i>
1	11.67	41.66	41.66
2	2.41	8.60	50.26
3	1.08	3.87	54.13
4	1.07	3.83	57.96

The change in the shape of the scree plot in Figure 1 suggested information regarding the number of the factors. The examination of the plot showed that there was a sharp decrease between first and second factors and the other changes were almost flattened. The examination of scree plot and initial eigenvalues might suggest that there was a second factor. However, the detailed analysis of items indicated that negative items loaded in the second factor. Since second factor is consisting of negative items, it could be inferred that this factor did not constitute a different or a second construct for the attitude questionnaire (Brown, 2006). In addition to this, since the original form of this questionnaire was reported as uni-dimensional (Bulut, 1994), number of factors could be retained as one (Büyüköztürk, 2011). In the later examination of factor structure of scale, one factor solution was forced.

In order to analyze the factor structure of the scale more precisely, the component matrix table was examined with unrotated loadings when the number of factors fixed to one. The examination of the loading of all items revealed that these loadings were higher than .40 except in this case of item 27. Since this item loaded .25 in the first component which was lower than the criterion value, it was removed from the scale. Hence, the analysis of component matrix yielded that there was one factor solution for this scale.

In this study, Cronbach's alpha coefficient was calculated as .94. In addition to checking internal consistency values of ATSQ, item inter-correlation values were examined. These values ranged from .40 to .74 which indicated that each item had a contribution to the scale.

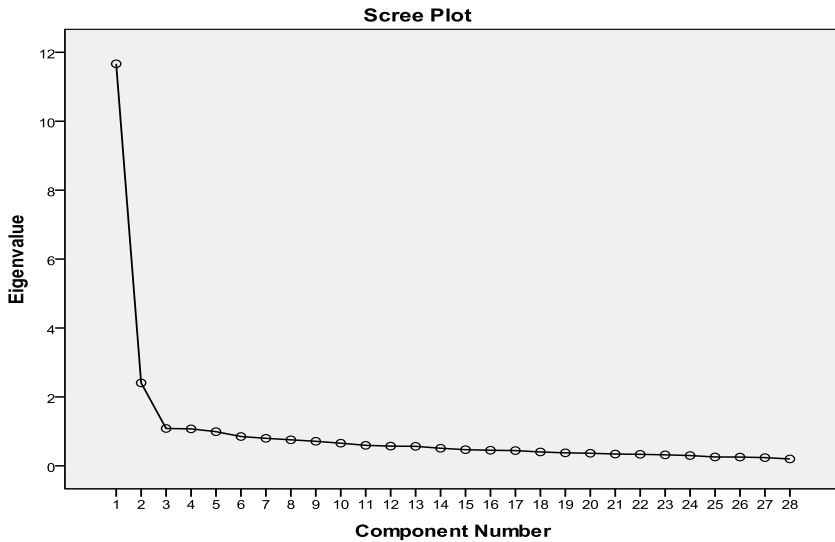

Figure 1. Scree Plot.

## 8<sup>th</sup> Grade Students' Attitudes towards Statistics

### Participants

The sample of this study was obtained through cluster random sampling in which comprehensive schools were randomly selected rather than students. Nine schools in an urban district of Ankara were randomly selected for the study. A total of 1034 8<sup>th</sup> grade students in these schools participated where 46.5% of them were male and 53.5% were female. The age of the students ranged between 13 and 15 with a mean age of 14.06. Majority of the participants of this study were coming from middle socioeconomic class families living in the selected urban district in Ankara. The mean of their latest mathematics grade was 3.4 out of 5.

### Data Collection and Analysis

Data were collected during spring semester of 2011-2012 academic year by the first author of this study. The demographic information sheet and ATSQ were administered to 8<sup>th</sup> grade students during their regular class periods by the researcher.

Quantitative research methodologies were used to analyze data through a number of descriptive statistics by using PASW 18 software. The responses to questionnaire items were assigned a numeric value from 1 to 5 with 1 addressing strong disagreement and 5 addressing strong agreement. For the items whose wording indicated a negative affective statement, the scale was reversed. A mean attitude score for each student was calculated by taking average of students' attitude scores for each item. Therefore, the maximum attitude value for each participant was 5 while the minimum was 1 where obtaining high scores from this questionnaire meant holding positive attitudes towards statistics.

## Results

The mean value of attitudes towards statistics scores of participants was 3.52 out of 5 where standard deviation was .74. In addition, the scores ranged between 1.14 and 5.00. From the descriptive statistics regarding ATSQ, it could be inferred that students had slightly positive attitudes towards statistics as the mean value was slightly more than the neutral value.

The analysis of mean distribution of items indicated that 8th grade students generally tended to agree with the attitude statements, yet their responses were around a neutral stance. In this study, attitudes towards statistics were defined as opinions and thoughts about statistics together with emotions and feelings experienced by students while learning statistics. In relation to the definition employed, the most notable finding based on mean distribution was that statements related to opinion had slightly higher mean scores compared to interest-related statements. 8th grade students tended to agree with opinion statements such as "Statistics enhances one's estimation ability" or "Statistics helps for mental development" where they were not sure about interest related statements such as "Statistics is not an interesting subject" or "I want more class hours related to statistics". They tended to disagree with the attitude statements incorporating anxiety or frustration such as "I get frustrated when I heard statistics" or "I am scared of statistics". Therefore, it could be inferred that students thought that statistics was important while they are not sure whether it was interesting or not. Table 2 gives the ATSQ items and their mean and standard deviation distributions.

*Table 2. Item Mean Distribution for ATSQ. Coding for negative items (R) is reversed, and higher value indicates more positive attitude for all items.*

<i>Item</i>	<i>Mean</i>	<i>SD</i>
I like statistics.	3,57	1,14
Statistics is unlikeable. (R)	3,62	1,17
I enjoy discussing about statistics.	3,25	1,21
Knowledge of statistics is annoying. (R)	3,54	1,22
Statistics help for mental development.	3,67	1,19
Knowledge of statistics makes me anxious. (R)	3,76	1,14
I want more class hours related to statistics.	2,88	1,29
Statistics can be learned easily.	3,62	1,21
I am scared of examinations about statistics. (R)	3,67	1,25
Statistics gains my interest.	3,37	1,24
Statistics have an important role for decision making.	3,59	1,18
Statistics makes me confused. (R)	3,54	1,16
I study statistics fondly.	3,36	1,20
If I could, I would not learn statistics. (R)	3,59	1,27
Statistics is not an interesting subject. (R)	3,13	1,32
I want to learn statistics in an advance level.	3,25	1,26
Statistics is used almost in every occupation.	3,67	1,14
I get bored when I study statistics. (R)	3,48	1,23
Statistics teaches individuals to think.	3,65	1,16
I get frustrated even when I hear the word "statistics". (R)	4,00	1,24
I am scared of statistics. (R)	3,78	1,22
Everybody needs to learn statistics.	3,42	1,23
I do not like statistics. (R)	3,58	1,27
Statistics enhances one's estimation ability.	3,80	1,18
I get bored while statistics is taught. (R)	3,44	1,24
Statistics has an important place in daily life.	3,56	1,21
Statistics is enjoyable.	3,37	1,37

## Discussion

The first purpose of this study was to develop a valid and reliable instrument measuring middle school students' attitudes towards statistics. The factor analysis was conducted in order to examine the underlying structure and one item was removed from the scale. The factor analysis indicated that ATSQ was a unidimensional scale. The factor analysis indicated that ATSQ was a valid and reliable instrument which assessed middle school students' attitudes towards statistics. The unidimensional structure behind ATSQ indicated that this instrument described general attitudes towards statistics without any specific dimension such as values or feelings. The underlying reason of unification of the dimensions was the definition of attitudes towards statistics given in this study, wherein attitudes towards statistics could be defined as the emotions and feelings including positive and negative responses experienced by individuals during learning statistics. Since this definition describes general attitudes and not addressing a specific affect, all the items placed in ATSQ were highly correlated to each other.

Several studies have documented that the attitudes towards statistics ranged between neutral to positive in the context of pre-college students when attitude was defined as opinions and values about statistics (Calderia & Mourino, 2010) and defined in terms of five aspects: enjoyment, confidence, usefulness, critical views and learning preferences (Yingkang & Yoong, 2007) which is consistent with the result of this study. The slightly positive attitudes of 8th grade students in this study might be connected to curriculum revision done in 2005 in Turkey. The revised Turkish mathematics education curriculum, in the context of statistics and probability, aimed to develop positive attitudes towards statistics and probability so that students understand the importance of statistics. The slightly positive attitudes of 8th grade students towards statistics in this study might suggest that the implemented curriculum had some effect on students' attitudes. Previous studies have revealed that more positive attitudes towards statistics are closely related to constructivist learning environment during statistics instruction (Cobb & Hodge, 2002; Mvududu, 2003). Turkish middle school mathematics teachers' professed practices have indicated that they used rather hybrid forms of instruction including both constructivist and traditional approaches (Haser & Star, 2009). The slightly positive nature of attitudes in this study may suggest that statistics concepts might be instructed in Turkish middle schools with this hybrid approaches despite the constructivist nature of mathematics teaching emphasized in the national curriculum (MoNE, 2005). In addition to this, statistical content consisted of applied topics rather than abstract concepts (Calderia & Mourino, 2010) for which students might tend to have slightly positive attitudes.

Statistics education has been rarely addressed in the Turkey and affect related to statistics has been a focus even less. We propose that ATSQ can be utilized in further research investigating middle grade students' attitudes towards statistics in relation to other variables. National curriculum context in Turkey also makes it possible to implement the questionnaire with a larger sample of Turkish students and generalize it to a larger group.

## References

- Bulut, S. (1994). *The effects of different teaching methods and gender on probability achievement and attitudes toward probability*. Unpublished Doctoral Dissertation, Middle East Technical University, Ankara.
- Büyüköztürk, Ş. (2011). *Sosyal Bilimler için Veri Analizi El Kitabı, İstatistik, Araştırma Deseni, SPSS Uygulamaları*. [Handbook of Data Analysis for Social Sciences, Statistics, Research Design, SPSS Applications]Ankara: Pegem Akademi Yayıncılık
- Brown, T. A. (2006). *Confirmatory factor analysis for applied research*. New York: Guilford.
- Calderia, S., & Hodge, L. (2002). Students' opinion on the subjects of statistics and probability in secondary schools of Lisbon, Portugal. In C. Reading (Ed.), *Data and context in statistics education: Towards an evidence-based society. Proceedings of the Eighth International Conference on Teaching Statistics (ICOTS8, July, 2010)*, Ljubljana, Slovenia. Voorburg, The Netherlands: International Statistical Institute. Retrieved April, 30, 2012, from [http://www.stat.auckland.ac.nz/~iase/publications/icots8/ICOTS8\\_C116\\_CALDEIRA.pdf](http://www.stat.auckland.ac.nz/~iase/publications/icots8/ICOTS8_C116_CALDEIRA.pdf)
- Carmichael, C. S. (2010). *The Development of Middle School Children's Interest in Statistical Literacy*. Unpublished Doctoral Dissertation, University of Tasmania, Tasmania.
- Cobb, P., & Hodge, L. (2002). Learning, identity, and statistical data analysis. In B. Philipps (Ed.), *Developing a statistically literate society: Proceedings of the Sixth International Conference on Teaching Statistics, Cape Town, South Africa*. [CD-ROM]. Voorburg, The Netherlands: International Statistical Institute. Retrieved April, 30, 2012, from [http://www.stat.auckland.ac.nz/~iase/publications/1/2e1\\_cobb.pdf](http://www.stat.auckland.ac.nz/~iase/publications/1/2e1_cobb.pdf)
- Gal, I. (2004). Statistical Literacy: Meanings, Components, Responsibilities. In D. Ben-Zvi, & J. Garfield (Eds.), *The challenge of developing statistical literacy, reasoning and thinking* (pp. 47-78). Dordrecht: Kluwer Academic Publishers.



- Gal, I., Ginsburg, L., & Schau, C. (1997). Monitoring attitudes and beliefs in statistics education. In I. Gal & J. Garfield (Eds.), *The assessment challenge in statistics education* (pp. 37-51). Amsterdam: IOS Press.
- Haser, Ç., & Star, J. R. (2009). Change in beliefs after first-year of teaching: The case of Turkish national curriculum context. *International Journal of Educational Development*, 29, 293-302.
- McLeod, D. B. (1992). Research on affect in mathematics education: A reconceptualization, In D. A. Grouws (Ed.), *Handbook of research on mathematics teaching and learning* (pp. 575-596), NY: Macmillan.
- Ministry of National Education [MoNE]. (2005). İlköğretim Okulu Ders Programları: Matematik Programı 6-7-8 (Elementary Curricula Programs: Mathematics Curricula Program for Middle Grades). Ankara: MEB.
- Mvududu, N. (2003). A cross-cultural study of the connection between students' attitudes towards statistics and the use of constructivist strategies in the course. *Journal of Statistics Education* 11(3). Retrieved April, 30, 2012, from <http://www.amstat.org/publications/jse/v11n3/mvududu.html>.
- National Council of Teachers of Mathematics. (2000). Principles and Standards for School Mathematics. Reston, VA: The National Council of Teachers of Mathematics.
- Philipp, R. A. (2007). Mathematics teachers' beliefs and affects. In F. Lester (Ed.), *Second handbook of research on mathematics teaching and learning* (pp. 257-315). Charlotte, NC: Information Age Publishing and National Council of Teachers of Mathematics.
- Schau, C. (2003). *Students' attitudes: the "other" important outcome in statistics education*. Paper presented at the Joint Statistical Meetings - Section on Statistical Education, San Francisco.
- Schau, C., Stevens, J., Dauphinee, T.L., & Ann, D.V. (1995). The development and validation of the survey of attitudes towards statistics. *Educational and Psychological Measurement*, 55(5), 868-875
- Shaughnessy, J. M. (2007). Research on statistics learning and reasoning. In F. K. Lester (Ed.), *Second handbook of research on mathematics teaching and learning* (pp 957-1009). Reston, VA: The National Council of Teachers of Mathematics.
- Tabachnick, B. G., & Fidell, L. S. (2007). *Using Multivariate Statistics*. Boston, MA: Pearson Education Inc.
- Ying Kang, W., & Khoon Yoong, W. (2007). Exploring attitude toward statistical graphs among Singapore secondary school students. *The Mathematics Educator*, 10(1), 39-58.
- Yılmaz, S. (2006). *The Effects of Real Data Based and Calculator Supported Statistics Activities on 7th Grade of Students' Statistics Performance and*

- Attitude Toward Statistics*. Unpublished Master Thesis, Middle East Technical University, Ankara.
- Watson, J., & Callingham, R. (2003). Statistical Literacy: A Complex Hierarchical Construct. *Statistics Education Research Journal*, 2 (2), 3-46.
- Watson, J. (2006) *Statistical Literacy at School: Growth and Goals*, Mahwah, NJ: Lawrence Erlbaum Associates.
- Wise, S. L. (1985). The development and validation of a scale measuring attitudes toward statistics. *Educational and Psychological Measurement*, 45, 401-405.



**ADULTS' VIEWS ON LEARNING AND DOING  
MATHEMATICS**



# Challenging parental beliefs about mathematics education

NATASCHA ALBERSMANN AND KATRIN ROLKA

albersmann@uni-wuppertal.de  
University of Wuppertal, Germany

## Abstract

*While the crucial role of beliefs in the teaching and learning of mathematics is widely acknowledged, the focus of previous research mainly lies on teachers' and students' beliefs. Parental beliefs, however, have been rather neglected. Considering current trends in mathematics education and its institutional integration the question arises to what extent parental beliefs correspond to these concepts of mathematical education. Therefore, the need occurs to investigate parental beliefs more closely. Against the background that a more active parental involvement in their children's mathematical education is an agenda for several countries, including Germany, a further aim is to encourage an enrichment of these parental beliefs. Herein, the focus lies on parents of secondary school students. This paper gives insights in underlying theoretical aspects as well as possible future activities.*

## Keywords

*parental beliefs, change of beliefs, parent-child cooperation*

## Introduction

The idea for investigating parents' mathematical beliefs is based on a previous study where one part of an inquiry focussed on parental experiences with and attitudes towards mathematics (Albersmann, 2011). One question in this study was: "When you think of mathematics, what do you spontaneously think of?" Some responses like "hard to understand, lots of practice, horror before the lessons, private tutoring, didn't get it" give cause for further investigations on parental beliefs about and attitudes towards mathematics. The mentioned quotations, for example, particularly indicate persistent experiences of incompetence expressed in a highly emotional way. One question that arises out of this is, which feelings do parents actually have regarding their mathematical competencies and resources to support their children? Altogether the study revealed, that, indeed, several parents feel uncertain about their abilities to help

their children with mathematics. Other responses to the question mentioned above referred to mathematics as “formulas and numbers or calculations”, which express a one sided view on mathematics. In the literature, this view has been labelled as toolbox aspect (Grigutsch, Raatz & Törner, 1997). Even aversions towards mathematics were stated such as “anxiety and cold sweat”. All in all, the need to examine parental views and beliefs about mathematics more properly and to think about possible supportive interventions emerged.

On the level of educational policies, a statement given by the German Conference of Ministers of Education and Cultural Affairs (KMK) recommends the integration of parents. In 2009, a decision was made in order to strengthen the so-called “MINT” subjects implying scientific, mathematical and technical education. In particular mathematics is met with little enthusiasm from young people as a school subject, course of studies or career choice. One of the KMK’s consequent interventions is to foster cooperative work with parents. More precisely, this is about encouraging and empowering parents to support their children’s scientific, mathematical and technical education (Kultusministerkonferenz, 2009).

While several European countries like Scotland, Finland or Norway have already established concrete initiatives to integrate parents more actively in the mathematical education of their children, those activities are lacking in many other countries, especially in Germany (Eurydice, 2011). However, parental support in mathematics can not at all be taken for granted. Considering current trends in mathematics education and the institutional embedding, for example, in national curricula or educational standards, the question comes up to what extent parental beliefs correspond to current concepts of mathematics education.

The critical role parents play in their children’s development is undeniable and their mathematics-related beliefs are likely to be one decisive parameter for their resources to support their children. However, existing research on parental beliefs about mathematics and mathematical education could hardly be found. Most of the research refers to elementary school students and their parents’ attitudes (Pritchard, 2004) and in one case even considers family involvement in mathematics (Onslow, 1992). Another research found on that topic investigates, indeed, beliefs of secondary school students and their parents, but refers only to one family (Krassnig, 2009). Hence the need to investigate parental beliefs especially from secondary school students more closely arises. Besides the investigation of parental beliefs another issue would be to challenge those beliefs and to encourage their development. This paper gives insights in underlying theoretical aspects and draws a conclusion for future research activities.

## Review of Literature

### Defining beliefs

In mathematics education, beliefs came to the fore when in the United States the National Council of Teachers of Mathematics (1980) called for more problem solving activities in the 1980s (Schoenfeld, 1985). In the meantime various empirical studies and theoretical considerations have contributed to deepen the insights into this complex construct. Nevertheless, there has not yet been, and probably should not be expected, a generally accepted definition of beliefs (Furinghetti & Pehkonen, 2002; recently brought forward again by Goldin, Rösken & Törner, 2009). Whereas some researchers strongly recommend the necessity to clarify the meaning of beliefs by giving a definition (Goldin, 2002; Pajares 1992; Thompson 1992), others emphasize “that the absence of consensus around definitions is not necessarily counterproductive, since beliefs constitute a very flexible and accommodating construct” (Goldin, Rösken & Törner, 2009, p. 3). Without attempting to formulate an all-embracing definition, we nevertheless point out some aspects frequently discussed in the literature that are especially relevant for parental beliefs.

One approach to define beliefs is to interpret them as a structure of attitudes, like it is described in the “three-component-model” by Triandis (1975). This model distinguishes between the components cognition, affection, and conation. While the cognitive component contains knowledge and concepts of the belief object, the affective component refers to the emotional relationship a person has to a belief object. Finally, conation means behavioural intentions and tendencies. These components mutually influence each other. They mostly are consistent, stable and lasting. Existing or arising inconsistencies among the three components influence the stability of the attitude structure and, thus, it gets open for change (Triandis, 1975).

Pehkonen and Törner (1996) define beliefs in a similar way: They distinguish between the two components of cognition and affection but take a closer look on the strength of each component in form of their consciousness.

An individual’s mathematical beliefs are the compound of his subjective (experience-based) implicit knowledge and feelings concerning mathematics and its teaching and learning. Conceptions could be understood as conscious beliefs, and thus differ from so-called primitive beliefs which are often unconscious. [...] In case of conceptions, the cognitive component will be stressed, whereas the affective component is emphasised in primitive beliefs. The spectrum of an



individual's beliefs is very large, and its components influence each other. [...] An individual's beliefs will form their own structure which we call his belief system (Pehkonen & Törner 1996, p. 102).

Furthermore, Pehkonen and Törner (1996) take up the approach by Pehkonen (1995) and divide the compound of beliefs into four main categories. These categories can be divided further into smaller elements. Here, some examples are given:

- beliefs about mathematics, e.g. beliefs on the nature of mathematics or beliefs on the subject of mathematics (as it is taught at school)
- beliefs about oneself within mathematics, e.g. beliefs concerning someone's self-confidence or beliefs regarding someone's mathematical competences
- beliefs about mathematics teaching, e.g. beliefs about the nature of teaching mathematics or about what the degree of autonomy given to pupils is
- beliefs about mathematics learning, e.g. beliefs about the nature of learning mathematics, beliefs about what the degree of autonomy expected from pupils is or beliefs about who sets the criteria for correctness.

This distinction clearly defines several elements of a person's mathematical belief system.

Beliefs are not only referred to as a complex, but sometimes also as a messy construct (Furinghetti & Pehkonen, 2002; Pajares, 1992). However, focussing on the composition of beliefs, some of this "messiness" can be reduced. Following Dionne (1984) and Ernest (1989), Törner and Grigutsch (1994) describe three components of mathematical beliefs: the toolbox aspect, system aspect, and process aspect. In the toolbox aspect, mathematics is considered as a set of rules, formulas, skills, and procedures. In the system aspect, mathematics consists of logic, rigorous proofs, exact definitions, and a precise mathematical language. In the process aspect, mathematics is seen as a constructive and creative process where the invention or re-invention of mathematics plays an important role. Later, Grigutsch, Raatz and Törner (1997) add the usefulness, or utility, of mathematics as another important component.

### Changing beliefs

As mentioned above, beliefs are considered as a complex construct and the formation of belief systems has not yet been clarified completely. However, as stated by Ball (1988) or Skott (2001) for teacher beliefs, parental beliefs

about mathematics, its learning and teaching as well as themselves within mathematics are probably to a large extent based on their own experiences as students. Hence, these beliefs are robust and consequently difficult to change (Schommer-Aikins, 2004). In the context of changing preservice teacher beliefs, one promising approach consists in involving them as learners of mathematics, usually submersed in a constructivist environment enabling them to discover mathematics for themselves (Ball, 1988; Feiman-Nemser & Featherstone, 1992; Liljedahl, 2005).

An approach for documenting conceptual change is given by Appleton (1997) who refers to the constructivist theory, as well. He elaborated a model for describing and analyzing students' learning. Therein he describes three different possibilities of what happens when learners, in our case parents, are confronted with new information and experiences.

The three possibilities Appleton (1997) distinguishes are:

- **Identical fit:** The new information is consistent with existing ideas. The learners are able to make sense of the new information in the context of their existing knowledge. However, this does not imply the correctness of the learners' explanations. Learners who feel that they have achieved an identical fit are most likely to quit the learning experience.
- **Approximate fit:** The new information seems to fit approximately to an existing idea. Some aspects are seen to be related, further details, however, remain to be unclear. In this situation the learners will not reach the point where a cognitive conflict could happen because they may encounter new ideas but will not give up old ones.
- **Incomplete fit:** The new information cannot be explained adequately by existing ideas or even is inconsistent with them. In the best case, this situation results in a cognitive conflict. The motivational factor that let the learners try to reduce the conflict is a feeling of dissonance or frustration.

In this model the main mechanism for change is cognitive conflict. Though, originally located in the context of knowledge change, this mechanism might be equally adaptable to the context of belief change (Rolka, Rösken & Liljedahl, 2007).

### Parental beliefs and influences on their children

Parental participation in learning activities at home seems to decrease with their children growing up, like it is shown in the Michigan Childhood and Beyond

Study or Maryland Adolescent Growth in Context Study (Eccles & Harold, 1996). The question is, why do parents withdraw from supporting their children's learning increasingly? Eccles and Harold (1996) mention two reasons that are relevant for beliefs: On the one hand, parents' efficacy beliefs, which means their confidence in helping their children with schoolwork especially when the subject areas get more specialised, and on the other hand, their attitudes towards school, which includes their previous history of positive and negative experiences at school or the role they believe the school wants them to play.

Moreover, whereas the cooperation between teachers and parents is much more distinctive in the earlier years of childhood, the collaborative relationship seems to decrease as children move into their adolescent years and into secondary schools, in particular in mathematics (Eccles & Harold, 1996).

Certainly, parents are not the only reference persons in childhood, but their influence on their children is crucial due to their omnipresence and emotional intensive relationship to them. The quality of a parent-child-relationship, however, is determined by the way parents get involved in their children's lives and their learning, as well. A study by Wild and Remy (2002) about affective and motivational consequences of parental learning facilities and attitudes towards learning clarifies that children have a higher self-determined motivation to learn, if their parents concentrate their attention rather on the learning process than on the learning outcome and if parents support their children's learning in an autonomous way. Those aspects build up key characteristics for parental support in their children's learning in general and in mathematics learning, as well.

Parental experiences with mathematics can be considered as one parameter that influence and shape their beliefs. Beliefs in turn build a filter that influences almost all of their thoughts and actions concerning mathematics. Accordingly, beliefs have an impact on how parents will behave in a mathematical learning situation and on how they are able to support their children's learning activities (Pehkonen & Törner, 1996). They form background factors for parents' thinking and acting. Thus, parents, who, for example, perceive mathematics as procedural drills, calculation strategies or for which the solution to a mathematical problem is more important than the process of finding the solution, probably are not able to support their children's motivation towards learning mathematics in a positive way (Wild & Remy, 2002).

## Conclusion and outlook

The decline of cooperation between secondary schools and parents on the one hand, and of parental engagement with learning activities at home on the other hand, necessitates closer parental involvement at least in the first years of secondary school. Hence, the transition to secondary school is a breaking point for parent-teacher cooperation. Moreover, many parents seem slightly anxious about their children coping with the new school situation and are highly interested in facilitating the transition for their children. Thus, the 5<sup>th</sup> and 6<sup>th</sup> grades appear to be appropriate to encourage parents to get more involved in their children's learning activities.

In order to incorporate parents in their children's mathematical education a project combining several workshops, where parents experience mathematics together with their children, seems particularly suitable. The workshops should be launched by the schools themselves and the participation should be encouraged by the mathematics teachers, in order to encourage closer cooperation between schools and parents and to communicate the need for parental involvement and support in their children's mathematical education.

The workshops should be accompanied by research on parental beliefs. For such a research the differentiation of mathematical beliefs by Pehkonen and Törner (1996) comprises particular relevant aspects. Parental beliefs about themselves within mathematics, for example, point to their perception of their ability to support their children with mathematics. As well, parents' beliefs about learning and similarly teaching mathematics give some indication of their strategies to support their children with mathematical problems. Additionally the four aspects of mathematical beliefs by Grigutsch, Raatz and Törner (1997), which fit into the earlier mentioned components by Pehkonen and Törner (1996), provide an analytical framework to classify parental statements about mathematics and its teaching and learning.

The key objective of the planned research is to unveil parental beliefs which run counter to current concepts of mathematics education like it is stated e.g. in national curricula or educational standards especially for secondary school. Furthermore, those beliefs need to be questioned, so that at best each parental belief system can be enriched or diversified. If we want parents to perceive mathematics as more than the procedural drills, calculation strategies or even a subject of aversion, then they must be provided with opportunities to experience and explore mathematics in a different way. Thus it is about reinforcing parents' expertise and ability to help their children with mathematical problems at home

in a supportive way. This could happen through composition of the workshops which should reflect current concepts of mathematics and mathematical education in order to challenge parental beliefs and encourage their development.

An issue that has to be clarified is, how to encourage the development of parents' pedagogical and mathematical knowledge, and, more critical yet, how to achieve a development of their belief systems. If parents have rigid views about how mathematics should be taught, they might get confused or will not open up to other approaches (Pehkonen & Törner, 1996). Hence, one question appears: Which stimuli are indeed necessary or useful to challenge established beliefs? Törner (2002), for example, states that stereotype approaches to mathematical problems foster limited and reduced perceptions. Here the approach of Ball (1988), Feiman-Nemser and Featherstone (1992) and Liljedahl (2005) mentioned above seems to be appropriate for parents as well.

With regards to content, including a great diversity in types of mathematical problems is essential. The composition of the workshop tasks should consider principles used in constructivist theories. This is about devising appropriate learning environments that address the subjective fields of experience of each person, but at the same time create new riddles. Consequently, the objective of the workshops is to create complex and authentic problems. It is essential that parents and their children are actively involved as learners in order to be able to develop their knowledge structure. The constructivist approach even seems particularly adequate for challenging parental beliefs and provoking a feeling of inconsistency, hence to provoke – in the terms of Appleton (1997) – an incomplete fit. Parents will go through an inner contradiction and will overcome it in a productive way during the experience of mathematics. Therefore, it is essential that the learning environments in the workshops reflect the nature of mathematics in a diverse way.

With regards to methods, one focus of such workshops should lie on the cooperative experience and exploration of mathematical tasks where parents work together with their children as a team. To accomplish this team spirit, it is necessary that parents let go of their typical roles; during the workshops they should not be the conveyer of knowledge or the director of operations but a learning companion and cooperate with their children in order to work on the problems together. Sometimes it is more fruitful to listen to children, to reflect on a problem, and to devise a problem-solving approach together. By this means parents can experience the importance of autonomy for a successful learning process. One possible method to develop a suitable learning environment is the "open approach". The use of investigations and open-ended problems seem to

offer the opportunity for a more meaningful teaching and learning experience (Pehkonen & Törner, 1996, p. 104).

Family math workshops as they are described above will be implemented for the first time in the school year 2012/13. The so called math-experience-days will start with parents and their children from an upcoming 5th grade of a Gymnasium in Cologne, Germany, and will take place three times a year on weekends for about three to four hours. The basic conditions are set, that means, the partner school agreed to promote the planned workshops and moreover is looking forward to integrate the project in its official school program. The first contact to the fifth-graders and their parents is established.

## References

- Albersmann, N. (2011). *Bedeutung von Elterneinstellungen auf das Interesse Ihrer Kinder für Chemie und Mathematik - Planung, Durchführung und Reflektion einer Fragebogenstudie*. Examensarbeit. Köln (not published).
- Appleton, K. (1997). Analysis and description of students' learning during science classes using a constructivistic-based model. *Journal of Research in Science Teaching* 34(3), 303-318.
- Ball, D. (1988). Unlearning to teach mathematics. *For the Learning of Mathematics*, 8(1), 40-48.
- Dionne, J. J. (1984). The perception of mathematics among elementary school teachers. In J. M. Moser (Eds.), *Proceedings of the 6th annual Meeting of the North American Chapter of the International Group for the Psychology of Mathematics Education* (pp. 223-228). Madison (WI): University of Wisconsin: PME-NA.
- Eccles, J., & Harold, R. (1996). Family involvement in childrens' and adolescents' schooling. In A. Book., J. Dunn (Eds.), *Family-School Links: How do they affect educational outcomes?* (pp. 3-34 ). New Jersey: Lawrence Erlbaum.
- Eurydice. (2011). *Mathematikunterricht in Europa: allgemeine Herausforderungen und politische Maßnahmen*. Brüssel: Eurydice.
- Ernest, P. (1989). The knowledge, beliefs and attitudes of the mathematics teacher: a model. *Journal of Education for Teaching*, 15(1), 13-33.
- Feiman-Nemser, S., & Featherstone, H. (1992). The student, the teacher, and the moon. In S. Feiman-Nemser & H. Featherstone (Eds.), *Exploring teaching: Reinventing an introductory course*. New York, NY: Teacher College Press.
- Furinghetti, F. & Pehkonen, E. (2002). Rethinking characterizations of beliefs. In G. C. Leder, E. Pehkonen & G. Törner (Eds.), *Beliefs: A hidden variable in*

- mathematics education?* (pp. 39-57). Dordrecht, The Netherlands: Kluwer Academic Publishers.
- Goldin G. (2002). Affect, meta-affect, and mathematical belief structures. In G. C. Leder, E. Pehkonen & G. Törner (Eds.), *Beliefs: A hidden variable in mathematics education?* (pp. 59-72). Dordrecht, The Netherlands: Kluwer Academic Publishers.
- Goldin, G., Rösken, B., & Törner, G. (2009). Beliefs - no longer a hidden variable in mathematical teaching and learning processes. In J. Maaß & W. Schlöglmann (Eds.), *Beliefs and attitudes in mathematics education. New research results.* (pp. 1-18). Rotterdam/Taipei: Sense Publishers.
- Grigutsch, S., Raatz, U., & Törner, G. (1997). Einstellungen gegenüber Mathematik bei Mathematiklehrern. *Journal für Mathematikdidaktik*, 19(1), 3-45.
- Krassnig, T. (2009). Parents' and their children's beliefs about mathematics (educaton). In: F. Furinghetti & F. Morselli (Eds.), *Proceedings of the conference MAVI-15: Ongoing research on mathematical beliefs.* (173-180). Genoa: University of Genoa.
- Kultusministerkonferenz: *Empfehlung zur Stärkung der mathematisch-naturwissenschaftlich-technischen Bildung*, Beschluss. 07.05.2009.
- Liljedahl, P. (2005). The effect and affect of mathematical discovery on undergraduate mathematics students. *International Journal of Mathematical Education in Science and Technology*, 36(2-3), 219-236.
- National Council of Teachers of Mathematics (1980). An agenda for action: Recommendations for school mathematics of the 1980s. Reston, VA: Author.
- Onslow, B. (1992). Improving the attitude of students and parents through family involvement in matheamtics. *Mathematics Education Research Journal*, 3 (A), 24 -31.
- Pajares, F. (1992). Teachers' beliefs and educational research: Cleaning up a messy construct. *Review of Educational Research*, 62(3), 307-332.
- Pehkonen, E. (1995). Pupils' View of Mathematics: Initial report for an international comparison project. University of Helsinki. Department of Teacher Education. Research Report 152.
- Pehkonen, E., & Törner, G. (1996). Mathematical beliefs and different aspects of their meaning. *International Reviews on Mathematical Education (ZDM)*. 28(4),101-108.
- Pritchard, R. (2004). Investigating parental attitudes and beliefs in mathematics education. In *Mathematics education for the third millennium : towards 2010: proceedings of the 27<sup>th</sup> annual conference of the Mathemacis Education Research Group of Australasia, held at Jupiter's Hotel, Townsville, 27<sup>th</sup> - 30<sup>th</sup> June 2004.*

- Rolka, K., Rösken, B., & Liljedahl, P. (2007). The role of cognitive conflict in belief changes. In J. H. Woo, H. C. Lew, K. S. Park, & D. Y. Seo (Eds.), *Proceedings of the 31st Conference of the International Group for the Psychology of Mathematics Education*. (Vol. 4, pp. 121-128). Seoul: PME.
- Schoenfeld, A.H. (1985). *Mathematical problem solving*. New York: Academic Press.
- Schommer-Aikins, M. (2004). Explaining the epistemological belief system: Introducing the embedded systemic model and coordinated research approach. *Educational Psychologist*, 39(1), 19-29.
- Skott, J. (2001). The emerging practices of novice teachers: The roles of his school mathematics images. *Journal of Mathematics Teacher Education*, 4(1), 3-28.
- Thompson, A. (1992). Teachers' beliefs and conceptions: A synthesis of research. In A. D. Grouws (Eds.), *Handbook of research in mathematics learning and teaching*. (pp. 127-146) New York: Macmillan.
- Törner, G., & Grigutsch, S. (1994). Mathematische Weltbilder bei Studienanfängern – eine Erhebung. *Journal für Mathematikdidaktik*, 15(3/4), 211-252.
- Törner G. (2002): Mathematical Beliefs - A Search for a Common Ground: Some Theoretical Considerations on Structuring Beliefs, Some Research Questions, and Some Phenomenological Observations. In G. Leder, E. Pehkonen & G. Törner (Eds.), *Beliefs - a hidden variable in mathematics education?* (pp. 73-94) Dordrecht, The Netherlands: Kluwer Academic Publishers.
- Triandis, H. C. (1975). *Einstellungen und Einstellungsänderungen*. Weinheim und Basel: Beltz Verlag.
- Wild, E., & Remy, K. (2002). Affektive und motivationale Folgen der Lernhilfen und lernbezogenen Einstellungen von Eltern. *Unterrichtswissenschaft*, 30(1), 27-50.





## Mixed methods in studying the voice of disaffection with school mathematics

GARETH LEWIS

G178@leicester.ac.uk  
University of Leicester, UK

### Abstract

*Disaffection with school mathematics is a complex phenomenon as well as a serious problem. It is clearly related to affect, but the study of affect in mathematics education is also problematic. A case is made that it is necessary to study the phenomenon beyond the quantitative study of attitude in order to understand better the complex and multi-dimensional nature of disaffection and to understand the subjective experiences of students who are disaffected. In order to do this, new methods and approaches are needed. This paper reports on a study of disaffected students of mathematics in a Further Education College. It describes the novel methods used to understand disaffection as a motivational and emotional phenomenon. The paper outlines a range of quantitative and qualitative methods used to elicit the subjective reality of disaffected students in relation to mathematics. It provides an opportunity to evaluate these methods, and their efficacy in capturing the dynamic nature of the motivational and emotional reality behind the phenomenon of disaffection.*

### Keywords

*disaffection, motivation, mixed methods*

### Literature Review

Disaffection with school mathematics is a serious problem. Concern about standards of achievement, both in the public domain in general, and in the research community specifically, have fuelled interest in the phenomenon. Disaffection is seen as related to poor performance, and is often identified and measured by attitude. Smith, Dakers, Dow, Head, Sutherland, and Irwin (2005) in their review of motivation in schools speak of current concern about significant numbers of pupils who are becoming disaffected and disengaged.

Alongside problems in attainment, evidence of negative attitude has also been documented. The Smith Report (Smith 2004) pointed out: “the failure of the curriculum to excite interest and provide appropriate motivation.”(p4) The report goes on to say: “(for many) GCSE Mathematics seems irrelevant and boring and does not encourage them to consider further study of mathematics.”

However, disaffection itself has not received the attention that this negative impact deserves. In the UK there have been a number of studies. Nardi and Steward (2003) widened the definition of disaffection to include ‘quiet disaffection’ that they discovered in school pupils. They characterized attitudes towards school mathematics as TIRED – tedium, isolation, rote learning, elitist and de-personalisation. Kyriacou and Goulding (2007) reported on the effectiveness of teaching strategies to raise the motivation of pupils studying mathematics in schools. They recognized the importance of encouraging student engagement in mathematics, and they refer to “the need for researchers to make greater use of measures and indicators of pupils’ motivational effort.” (p2) They proposed a model that related attitude to motivational effort and thus to attainment.

Brown, Brown, and Bibby (2007) examined reasons for participation and non-participation in mathematics beyond age 16. They noted that 37% of students characterized mathematics as boring, and they identified the perceived difficulty of the subject and low efficacy as key other factors that influence students in not choosing to study the subject further. Interestingly, and in contrast to Nardi and Steward, they encountered disaffection charged with negative emotion. This suggests that the phenomenon of disaffection may be more complex than the statistical study of binary oppositions such as positive and negative attitude or positive or negative self-efficacy represents. Since disaffection is clearly related to affect, and since affect itself is highly complex and problematic in research terms (Hannula, Pantziara, Waegel, and Schloglmann 2010), then this is perhaps not surprising. Support for this argument comes also from other sources. For instance, Cremin, Mason, and Busher (2011) also conclude that disaffection is more complex than simple categorisation allows.

This complexity surrounding attitude in mathematics education has been recognized more widely. Schorr and Goldin (2008) argue for “the need to study affect more deeply than the study of attitude permits.” (p132) And further “It is increasingly clear that the functioning of affect is far more complex than is suggested by considerations of positive versus negative emotions and attitudes.” (p133). The Cerme group on affect has noted the multidimensional and complex nature of affect and the need to widen the methods used to study it (Hannula et al. 2010).

## The current study

The current study was undertaken with the purpose of understanding more fully the phenomenon of disaffection beyond attitude. Only by understanding the problem more fully and in all of its complexity is it possible to gain traction on the problem and make it subject to improvement through policy, curriculum or teaching practice. In addition, there is too little evidence of the subjective experience of disaffection from the voice of the student. Thus the current study was conducted from a phenomenological and constructivist position, with a focus on motivation and emotion. Reversal Theory was used as a coherent account and framework of motivation and emotion from a phenomenological perspective (Apter 2001).

The study involved students in two further education colleges. Since 'failing' mathematics in school, they are required to study a Use of Mathematics course. It is reasoned that this low achievement, together with the compulsory aspect of their participation means it is likely that many of these students will be disaffected with mathematics. In the first instance, a total of 130 students from four classes in each college, were surveyed using the instrument described below. This data, together with teacher comments and observational data, was used to identify students who were likely to be disaffected with mathematics. Students were invited to volunteer for interview, so in this sense, the interview population of 22 students represents an opportunity sample.

## The methods

A mixed methods approach was adopted, with a quantitative survey used alongside a range of qualitative methods to elicit aspects of the experiences and the subjective meanings of that experience.

The Tension and Effort Stress Inventory (TESI), (Svebak 1993), was designed to be a one-page survey measure with an integrative orientation to the experience of stress. It is based on the Reversal Theory account of unpleasant emotions or moods. "The TESI has proved to be a practical instrument for quantitative assessments of the subjective experience of exposure to stressors." (Svebak 1993, p204). It can be used on a face-value basis without recourse to the theoretical assumptions inherent in its design. It is based not on behavioural or biological bases of stress, but about the subjective experience of stress. A stressor is a source that gives rise to the experience of unpleasant emotions (called tension-stress). Tension stress is the perceived difference between our motivational need at that moment compared to our felt experience. The eight emotions are : boredom,

anxiety, anger, sullenness, humiliation, shame, resentment, guilt. It is reasoned that disaffection will be associated with the experience of such unpleasant emotions. The test was adjusted to make the wording appropriate and relevant to the mathematics education context (TESI-ME). In addition, the labels for the emotions were altered where necessary to reflect current language use within this social context. Students were asked to report the degree to which, in relation to mathematics, they experienced stress, effort, and eight negative emotions on a likert-type scale from 1 to 7.

The purpose of the questionnaire in this study was to gauge the prevalence of negative moods and emotions in a group of students who were likely to be disaffected. It was seen as a way of characterising disaffection through emotion rather than attitude. In effect it provides answers to the questions; *'how stressed are you about mathematics?'* and *'how do you experience that stress?'*

Qualitative data was acquired in interviews. However, since the population was likely to include students who may not be highly articulate about their own motivational and emotional landscape, it was decided to employ a number of techniques to provide stimulus and structure to the elicitation of data. There are precedents for such techniques in social-psychological research, and more specifically in educational research. However, there is very little evidence of their use in mathematics education.

One of these methods ('me and mathematics' – see below) is a participant-generated visual technique. Such visual methods are increasingly being used in educational research, as they seem to be particularly useful for younger, less articulate or marginalised groups (Davidson, Dottin, Penna, and Robertson 2009). Chula (1998) has investigated the use of drawings as a methodological technique for visual data analysis in the study of the perceptions of adolescent's experience of education. She concluded that drawings are useful as a singular source of interpretive inquiry, and she makes the case for drawings in research as an alternative, non-discursive form of knowing. Chula sets out a number of purposes that the use of drawings can satisfy. These include: as a stimulus to the retrieval of thoughts; as a means of expression and articulation where words are difficult to find; as an interface between the interviewer and the individuals. She also points out that a further advantage is that new and emerging theories of learning have implied a range of learning styles, and that the techniques under discussion can offer a means of expression for people with more visual styles of learning.

Borthwick (2011) also uses visual techniques in her investigation of young pupils' views in relation to their experience of school mathematics. She points out that

visual representations can be used to elicit expressions and emotions for pupils for whom verbal expression may not be easy. Davidson et al. (2009) also argue the case for the use and acceptance of visual sources in qualitative research. Their study encompasses a number of features that characterise the most important affordances of using visual sources. One of these is the access they give to complex realities and multi-layered meanings in the subjective experience of those studied. That these methods are able to access meanings, interpretations and themes not possible through other methods is also reported by Sewell (2011). Davidson et al (2009) report the work of Dottin, who talks of "the hidden consciousness of their experience", and states that "visual images have the capability of bypassing cognitive defences of our experience to tap directly into our emotional and spiritual/intuitive zones of consciousness" (Davidson et al. 2009, p10).

However, a number of commentators also point out that such visual data can be reinforced by combining it with other means such as interviews. For instance, Chula states "When interpreting beyond what is visible and descriptive, other methodological techniques such as written narrative and interviews are necessary to clarify ambiguity and vague symbols, and to maintain the integrity of the stories told." (Chula 1998, p1). This is echoed by Croghan et al. (2008) who say "combining verbal and visual forms of self-presentation allows individuals more scope for presenting complex, ambiguous and contradictory versions of the self" (p355). Chula also points out the importance of the interview alongside the drawing. This not only allows for the elicitation of meaning of the drawings, but allows for the elicitation of data beyond the drawing itself.

Another methodological approach used was the card sort. Based on the original idea of the Q-sort, developed by William Stephenson in the 1930's, the use of techniques of selecting/sorting prompts presented on cards has been used and developed over the years in psychological and sociological research. Indeed there has been a substantial number of papers published referring to the technique (Thomas and Watson 2002). They comment that the method offers "a powerful, theoretically grounded, and qualitative tool for examining opinions and attitudes." (Thomas and Watson 2002, p141). Although the original method is structured by having participants rank statements on cards, and thus producing quantitative analyses, the method used in this study was modified by simply asking participants to choose cards that represented their own experiences. These choices could then be discussed at interview.

We can now look at the individual techniques captured during the interview.

## Life history

This instrument, labelled '**Me and mathematics**', is a grid with a horizontal axis marked out with school years 1 through 12, and a vertical axis marked from -5 to +5. Students were invited to place a point on the scale for each school year. In this way, they plotted visually their mathematics life history. This was then discussed in the interview, with particular attention given to the 'dips'. This simple instrument enables the exploration of the question; '*How has your relationship to mathematics changed over the years*', and subsequently, '*What causes rises and falls in affect?*' The sample of 22 students is not big enough or representative enough to allow for generalisation. If there is one pattern it is that there is no pattern – the responses are highly individual. In about a third of these life histories, the early years are most positive, but for 6 of them, the early years are the most negative. For another third, there is a dip on transfer to secondary. One interesting feature is the influence of contingent factors affecting 'dips' which emerged. Moving country, being ill, losing a parent and a whole range of out-of-classroom factors had a massive (and often poignant) effect. Two key factors that seem to be associated with dips in affect are testing and being placed in a lower grouping – what Boaler (2010) has called 'brutal labelling'.

## Card sort

During the course of the interview, students were then offered two sets of coloured **cards** in turn and asked to choose those cards which represented something meaningful about their own experience of mathematics. The first set of cards represented positive emotions, as indicated by Reversal Theory. The emotions included: excitement/curiosity, relaxed, mischievous/playful, proud, virtuous, modest, grateful. In the second set, each card was labelled with a motivationally significant or valent word or phrase – again all positive. Again, these were suggested by the eight motivational states as defined in Reversal Theory. They included: feeling cared for, sense of achievement, freedom, sense of purpose, helping others, powerful/in control, feeling part of the group, having fun, sense of duty. The card sort is an attempt to understand the presence of more positive affect in the experience of these students. In effect, it answers the questions: '*In what ways do you feel positive emotion, what motivates you, and where do you derive satisfaction?*'

## Results

Although the TESI-ME is a quantitative instrument, there are issues of reliability and validity, and it is not appropriate to generalize from the results. The primary

purpose is as a stimulus for the student to describe and discuss aspects of their relationship to mathematics, and thus the data is seen as significant to that individual. However, a descriptive account of the sample is also interesting. In terms of overall stress, the mean score was 4.4 (out of a possible 7), suggesting that the experience of stress is present and strong for many in this population. 26 of the students (21%) scored 6 or 7, but there were large individual variations. Effort scores were also high (mean = 4.7). However, it can't be discounted that there is an element of social desirability in the effort scores. If we look at the mood scores themselves, boredom stands out as the most problematic (mean = 4.1). Within the distribution, anxiety, humiliation, shame and guilt also figure. If we look at individuals, we see a wide variation in responses. The mean for the total stressor score (by totalling the eight mood scores for each respondent) is 21.4, with individual totals ranging from as low as 9 up to 53 (out of a possible 56), and with 20 students (16%) scoring 32 or more. Individual responses to the survey were available and discussed in the subsequent interviews.

In terms of the card sort, all students were able to identify positive emotions and feelings, and to describe in quite vivid ways how these come about, and their meaning for them.

The most chosen positive emotions were *pride* and *relaxation*. Pride was usually associated with being able to understand or do something, or to the achievement of test or exam results. Relaxation relates to the experience of being able to cope, to do what was being asked. It is the absence of anxiety. *Mischievous/playful* and *excitement/curiosity* were chosen by approximately a quarter of the interviewees. The two most chosen cards representing feelings related to individual states were *achievement* and *helping others* (both chosen by half of the students). Other cards chosen frequently include *freedom*, *being part of the group*, *fun/enjoyment*, *powerful/in control* and *sense of duty*. These choices were supported by strong personal stories and examples. It is interesting to see that the experience of mathematics, even for the most disaffected, is punctuated by these more positive affect and episodes. This in turn suggests that aspects of their motivation are, as it were, 'turned on' and alert for motivational opportunities and experiences.

## Conclusions

The primary aim of the study was to understand more fully the subjective experience of students of mathematics, and in particular to gain insight into the experience of disaffection with school mathematics from a motivational and emotional point of view. In this paper the rationale for the methods used and the methods themselves are described. The brief quantitative summary here



has given some impressions of the depth and extent of the negative experience of these students. However, this has also been balanced by the more positive experiences represented by the card sort data.

The data itself can be analysed in a number of ways. Each interview transcript represents an individual case study, and a small number of these are currently being analysed and written up. The data is also being analysed thematically across cases, and some interesting themes are already emerging. In these analyses, the prevalence and depth of the negative experience becomes apparent. So too, does the volatile nature of these students' relationship to mathematics. It is also clear that disaffected does not mean unmotivated. Whilst many of these students are clearly disaffected, they are also strongly motivated, but failing to gain the satisfaction their motivation requires. A small number of the interviews can be characterized by a 'dominant narrative' – being suffused with an overriding theme that weaves in and out of the narrative. Examples include 'struggle', confidence (loss of), and competitiveness.

These emerging themes will be reported more fully in future publications.

## References

- Apter, M. J. (Ed.). (2001). *Motivational styles in everyday life: A guide to reversal theory*. Washington,DC: American Psychological Association.
- Boaler, J. (2010). *The elephant in the classroom*. London: Souvenir Press.
- Borthwick, A. (2011). Children's perceptions of, and attitudes towards, their mathematics lessons. Paper presented at Smith, C. (Ed.) *Proceedings of the British Society for Research into Learning Mathematics 31 (1)*, London.
- Brown, M., Brown, P., & Bibby, T. (2007). 'I would rather die.' attitudes of 16 year-olds towards their future participation in mathematics. In Kuchemann, D. (Ed.), *Proceedings of the British Society for Research in Learning Mathematics 27 (1)*, London.
- Chula, M. (1998). Adolescents' drawings: A view of their worlds. Paper presented at Annual Meeting of the American Educational Research Association, San Diego, CA.
- Cremin, H., Mason, C., & Busher, H. (2011). Problematising pupil voice using visual methods: Findings from a study of engaged and disaffected pupils in an urban secondary school. *British Education Research Journal 37 (4)*: 585-603.
- Croghan, R., Griffin, C., Hunter J., & Pheonix, A. (2008). Young people's construction of self: Notes of the use and analysis of the photo-elicitation

- methods. *International Journal of Social Research Methodology* 11 (4): 345-56.
- Davidson, J., Dottin, J., Penna, S., & Robertson, S. (2009). Visual sources and the qualitative research dissertation: Ethics, evidence and the politics of academia - moving innovation in higher education from the center to the margin. *International Journal of Education and the Arts* 10 (27). Retrieved [05/12/2012] from <http://www.ijea.org/v10n27/>.
- Hannula, M., Pantziara, M., Waege, K., & Schloglmann, W. (2010). Introduction: Multimethod approaches to the multidimensional affect in mathematics education. In V. Durand-Guerrier, S. Soury-Lavergne & F. Arzarello (Eds.), *Proceedings of CERME 6, January 28th-February 1st 2009, Lyon France*, (pp. 28-33). INRP 2010.
- Kyriacou, C., & Goulding, M. (2007). Researching classroom activities to raise secondary school pupils motivational effort in mathematics. *Psychology of Education Review* 31 (1): 34-40.
- Nardi, E., & Steward, S. (2003). Is mathematics T.I.R.E.D.? A profile of quiet disaffection in the secondary mathematics classroom. *British Educational Research Journal* 29 (3): 345-67.
- Schorr, R. Y., & Goldin G. A. (2008). Students' expression of affect in an inner-city simcalc classroom. *Educational Studies in Mathematics* 68 : 131-48.
- Sewell, K. (2011). Researching sensitive issues: A critical appraisal of 'draw-and-write' as a data collection technique in eliciting children's perceptions. *International Journal of Research and Method in Education* 34 (2).
- Smith, A. (2004). *Making mathematics count : The report of professor adrian smith's inquiry into post-14 mathematics education*. London: The Stationary Office.
- Smith, C., Dakers, J., Dow, W., Head, G., Sutherland, M., & Irwin, R. (2005). *A systematic review of what pupils, aged 11-16, believe impacts on their motivation to learn in the classroom*. London EPPI-centre, Social Science Research Unit, Institute of Education, London.
- Svebak, S. (1993). The development of the tension and effort stress inventory (TESI). In J. H. Kerr, S. J. Murgatroyd, M. J. Apter (Eds.), *Advances in reversal theory* (pp. 189-204). Lisse Netherlands: Swets & Zeitlinger Publishers.
- Thomas, D. M., & Watson, R. T. (2002). *Q-sorting and MIS research: A primer*. Paper presented at Communications of the Association for Information Systems.



# Gender differences in university students' view of mathematics in Estonia

INDREK KALDO AND MARKKU S. HANNULA

ikaldo@tlu.ee  
Tallinn University, Estonia

markku.hannula@helsinki.fi  
Helsinki University, Finland

## Abstract

*This study reports on first-year Estonian university students' view of mathematics. The data was collected from 970 university students of different disciplines using a Likert-type questionnaire and six underlying dimensions. Performance-Approach Goal Orientation was the only dimension where no statistically significant gender difference was found. In all the remaining dimensions, the female respondents were more positive towards mathematics: They had more powerful mastery orientation, they valued mathematics more, they felt more competent, they perceived their teachers more positively and they were less inclined to cheat.*

## Keywords

*view of mathematics, university level, gender differences*

## Introduction

Students' affective relationship with teaching and learning of mathematics plays an important role in mathematics education (McLeod, 1992). The study of students' mathematical affect has received continuous attention since the 1990's. The extensive research regarding gender and mathematics education has reported males to have higher achievement, higher participation rates, and more favourable attitudes and beliefs about mathematics (e.g., Leder, Forgasz & Solar, 1996). However, studies have shown gender differences in achievement to be declining and disappearing in several countries (IEA / TIMSS, 2003; OECD / PISA, 2003) and some changes have also been reported over time with respect to gender-stereotyped attitudes and beliefs (e.g., Forgasz, Leder & Kloosterman, 2004). Gender differences in mathematics achievement and its relationship to societal expectancies and other variables such as parental involvement, teacher beliefs, teacher- students interactions, autonomous learning behaviors, self-

efficacy and persistence theory (Fennema, 1990; Fennema, & Peterson, 1985; Hannula, Maijala, Pehkonen, & Nurmi, 2005), and beliefs that mathematics is a male domain (Hyde, Fennema, & Lamon, 1990; Forgasz, et al., 2004) are well documented in the research literature.

Research on mathematics-related attitudes and beliefs has been rather separate from research in motivation, the previous having been more popular among mathematics educators and the latter among educational psychologists (see Hannula, 2011 for elaboration). In order to emphasize the present focus on combining these main trends we use the term *view of mathematics* in this paper. It is also an appropriate term for our aim to analyse the structure of students' mathematics-related affect. The term *view of mathematics* was originally introduced by Schoenfeld (1985) and later adapted by others (Pehkonen, 1996; Pehkonen & Törner, 1996). The students' view of mathematics is a result of their experiences as learners of mathematics and as such, it provides an interesting window through which to study the teaching of mathematics.

One developing aspect of research on mathematics related beliefs has been the identification of its different dimensions (e.g. Op't Eynde, De Corte & Verschaffel, 2002), and the way these dimensions relate to each other (Roesken, Hannula & Pehkonen, 2011; Kaldo & Hannula, 2012).

In this study we use an instrument that joined together parts of some previously published instruments on mathematical beliefs/attitudes and motivational orientation to mathematics (Kaldo & Hannula, 2012) to compare gender differences among Estonian university students.

## Gender differences in mathematic-related affect

There used to be clear gender differences favouring males in large-scale mathematics performance tests (Hyde, Fennema & Lamon, 1990). PISA 2003 results (OECD, nd) revealed that males generally outperformed females, while gender differences were found for some countries but not in others in TIMSS 2003 (Mullis, Martin, Gonzalez & Chrostowski, 2004). Moreover, Hyde, Fennema and Lamon (1990) concluded that the gender differences in mathematics performance, even among college students or college-bound students, were at that time at most moderate.

Moreover, as soon as mathematics becomes optional in schools, there tends to be overrepresentation of male students over female students in mathematics courses and this is also reflected in their respective test performances. This leads to a

widening gender gap in performance as students get older. At the university level, mathematics programs typically attract mainly male students (Grevholm, 1996; Hag, 1996). Yet, mathematics teacher education programs typically attract more female students (Finne, 1996).

As numerous studies on achievement differences indicate, there is no reason to believe that female students are underrepresented due to inferior mathematics skills. Rather, female students tend to opt out of mathematics more often than male students at equal performance levels. Some studies have indicated that students tend to perceive mathematics as a male domain (Frost, Hyde, & Fennema, 1994), but this belief is mainly held by male students and hence does not give an appropriate explanation for female underrepresentation in mathematics.

Studies on students' mathematical self-efficacy beliefs have produced very consistent results that indicate that across age and performance levels female students tend to have lower self-efficacy in mathematics than male students (e.g. Hannula, Maijala, Pehkonen & Nurmi, 2005; Nurmi, Hannula, Maijala & Pehkonen, 2003; Leder, 1995). Female students also suffer mathematics anxiety more often than male students (Frost et al., 1994; Hembree, 1990). Nurmi, Hannula, Maijala and Pehkonen (2003) study indicates that the gender difference in self-confidence can be observed among those students who had received the highest grade in mathematics.

Andrews, Diego-Mantecón, Op 't Eynde and Sayers (2007) discovered that girls both in Spain and England, regardless of age or nationality, were less positive in their beliefs about their own competence than boys. In terms of mathematics being inaccessible and elitist, they found that both males and females shared this negative view; however, females had a significantly more negative viewpoint. Finally, they found that both the boys and girls in their study were equally positive in terms of their teachers as facilitators of their learning and of the relevance of mathematics to their lives.

These results regarding gender differences in mathematics-related self-efficacy beliefs provide an explanation for why female students usually choose not to study optional mathematics. There is no reason to believe that female students' low self-efficacy beliefs is a natural and permanent gender characteristic of the female sex. The research has accumulated evidence for the hypothesis that female students' lack of confidence in mathematics is consistent with their teachers' beliefs (Li, 1999; Soro, 2002; Sumpter, 2009) and that teachers' typical interaction patterns with male and female students may thus contribute to the generation of gender differences. Mathematics teachers tend to believe that their male students often

have hidden talent, but due to being lazy and careless they underperform, while female students tend to reach their performance potential due to diligence and hard work even if they are not very talented. These teacher beliefs are assumed to lead to different feedback to male and female students and thus to contribute to the observed gender differences in self-efficacy beliefs. However, there are countries where the female students have a more positive attitude. For example, Li (2007) found that in Canada, in general, female students tend to enjoy learning mathematics and think it is more important to learn it than male students do.

In a sample of college students, Baird (1980) found that males admitted to cheating more than females did. Males also said they cheated on more types of tests and used a greater variety of cheating methods. Females said they disapproved cheating more than males did and were more likely to feel guilty if they did cheat.

Large-scale studies of secondary mathematics students (Fennema & Sherman, 1977, 1978; Armstrong, 1981), tended not to find gender-related differences in students' attitudes to success in mathematics, but did find links between these attitudes and the students' achievement and enrolment in mathematics courses. Leder (1982) found that, among high achieving secondary school mathematics students, females showed more ambivalence about their success than males did. Norton and Rennie (1998) did not find gender differences in attitudes to success, but did find that a single-sex school environment was associated with more favourable attitudes. A substantial amount of data has been gathered on the differences between males and females in confidence in doing mathematics, but very little on how children develop a belief in themselves as autonomous learners (Fennema and Peterson, 1985). The nature of the attributions of male and female students has been an important theme in mathematics education. Males are more likely than females to attribute their success in mathematics to ability, while females are more likely than males to attribute their failures to a lack of ability (McLeod, 1992). In addition, females tend to attribute their success to extra effort more than males do, while males tend to attribute their failures to a lack of effort more than females, which is formulated as a theory of "learned helplessness" (Licht & Dweck, 1987). For example Fennema and Peterson have noted that gender differences in participation in mathematics-related careers appear to reflect these gender differences in attributions (Fennema, 1989; Fennema & Peterson, 1985).

The Brandell, Nyström and Sundqvist (2004) study in Sweden shows that it is fairly common – among both sexes – to regard mathematics as a male domain in some respects. In their study, all subgroups tended to perceive that men are

more likely than women to like challenging mathematical problems, to find mathematics easy and expect to need mathematics in their future lives. Women, on the other hand, are associated by many, especially by female students, with negative aspects of mathematics, such as more often finding mathematics to be boring and difficult. On the other hand, they are supposed to work hard and worry about their performance. Interestingly enough, female students suggest that women more often than men find it important to understand mathematics (Brandell, Nyström & Sundqvist, 2004).

There are fewer studies on mathematics-related beliefs at the tertiary level. Studies at the university level typically focus on mathematics majors (Yusof & Tall, 1994), teacher education students (Hannula et al., 2006, Juter, 2005) or students of compulsory statistics courses (Murtonen, Olkinuora, Tynjälä and Lehtinen, 2008). Gender differences of Estonian university students' views of mathematics are – to the present day – an unexplored area.

More recent studies have provided new details of gender differences in mathematics-related affect. Op 't Eynde and De Corte (2003) explored the mathematics-related beliefs of Flemish junior high school students and how they related to gender, achievement levels, and educational track. The results indicated that students' mathematics-related belief systems were interconnected very strongly with the educational track in which they were taking their mathematics courses, but also with gender and the way the teacher evaluated their achievement levels. Hannula, Kaasila, Laine and Pehkonen (2006) found in their study a core of the view of mathematics, which consists of three closely related elements: belief in one's own talent, belief in the difficulty of mathematics, and the fondness for mathematics. They found gender differences in self-confidence, but they did not find them in the fondness for mathematics or perceiving mathematics to be difficult. In addition, female students perceived themselves to be more hard-working and diligent than male students.

In the study Lam, Jimerson, Kikas, Cefai, Veiga, Nelson, Hatzichristou, Polychroni, Basnett, Duck, Farrell, Liu, Negovan, Shin, Stanculescu, Wong, Yang, & Zollneritsch (2011) examined gender differences in student engagement and academic performance in school. Participants included 3420 students (7th, 8th, and 9th graders) from Austria, Canada, China, Cyprus, Estonia, Greece, Malta, Portugal, Romania, South Korea, the United Kingdom, and the United States. The results indicated that, compared to boys, girls reported higher levels of engagement in school and their teachers rated their academic performance higher than that of girls. Student engagement accounted for gender differences in academic performance, but gender did not moderate the associations among



student engagement, academic performance, or contextual supports. Gender differences might become more evident when children get older (e.g., Ai, 2002).

Kikas, Peets, Palu and Afanasjev (2009) examined the development of 269 Estonian primary school children's (119 boys and 150 girls; 20 classes) mathematics skills. Testing was carried out over a three-year period (Grade 1–Grade 3). As regards gender differences, girls and boys showed similar development and similar final level of mathematics competencies. Kislenko (2009) analysed the differences between gender and grade in Norway and Estonia. In her work, from the perspective of gender, the only significant difference appeared in the factor insecurity as boys in general claimed to be less afraid of making mistakes and becoming nervous in tests situations in mathematics than girls.

There are no previous survey studies about Estonian university students' gender differences in mathematics related affect. The aim of this research was to fill this gap by comparing gender differences among Estonian university students' view of mathematics. That present study also continues the integration of motivation research with belief research in the context of mathematics learning.

## Methodology of research

### Instrument

The view of mathematics indicator used in this research has combined scales from six previously published studies (for details, see Kaldo & Hannula, 2012). We could not confirm all scales in our study. Seven factors had high Cronbach's alpha (in range 0.74-0.82) and their reliability for Estonian university students was confirmed (Kaldo & Hannula 2012). Due to high correlation between two of the scales and high similarity in their content, we decided to combine two of the scales (Relevance and Personal Value), constructing a new scale Value of Mathematics that had high reliability. The confirmed structure in this study relates to structures in Diego-Mantecon et al. (2007) regarding the factors Relevance, Student Competence and Teacher Role, but our study did not confirm the factor Mathematics as a Rote Learnt Subject. Compared to the Roesken, Hannula and Pehkonen (2011) study, our structure confirmed the factor Student Competence, but not the factor Effort. The structure of students' view of mathematics in this paper was concluded to consist of the following six confirmed factors: Performance-Approach Goal Orientation, Mastery Goal Orientation, Relevance, Value of Mathematics, Student Competence, Teacher Role and Cheating Behaviour.

In the study, the students responded on a four point Likert scale (from strongly disagree to strongly agree). The survey was carried out in Estonia in the autumn of 2009; the students were guaranteed anonymity and given 45 minutes to fill out the questionnaire. Table 1 shows the distribution of responses from first-year mathematics course students across one private and four public law Estonian universities: the Estonian Business School (hereinafter *EBS*), Tallinn University (hereinafter *TLU*), Tallinn University of Technology (hereinafter *TUT*), Tartu University (hereinafter *UT*) and the University of Life Sciences (hereinafter *ULS*). The participants in this study were volunteering bachelor students taking at least one first-year compulsory mathematics course at the university level. The survey was completed during compulsory mathematics lectures and participation was voluntary. The average age of responding students was 19.7. Altogether 970 students responded; 508 were male and 462 were female.

*Table 1. Sample description.*

<i>University</i>	<i>No. of students in the sample</i>	<i>Percentage of students in the sample</i>	<i>Male</i>	<i>Female</i>
EBS	91	9.4 %	43	48
ULS	228	23.5 %	130	98
TLU	103	10.6 %	52	51
TUT	314	32.4 %	185	129
UT	234	24.1 %	98	136
Total	970	100.0 %	508	462

## Results of research

In the following section, we will present some results regarding the structure of the view of mathematics before reporting observed gender differences. We used the statistical program SPSS Statistics for the data analysis.

We made a t-test between male (508) and female students (462) in order to analyse gender differences for each subscale (Table 2).

Let us first look at the overall trend in the results. The component Mastery Goal Orientation got the highest level of agreement. Neutral positions were taken for three dimension: Value of Mathematics, Student Competence and Teacher Role. The lowest levels of agreement were received in Cheating Behaviour and Performance-Approach Goal Orientation.

Table 2. Factors: mean values for genders, their standard deviation, and statistics of *t*-test.

Component	Gender	Mean	Standard deviation	<i>t</i>	Sig. (2-tailed)
Performance-Approach Goal Orientation	Male	1.98	0.672	-0.558	.577
	Female	2.003	0.630		
Mastery Goal Orientation	Male	2.823	0.555	-6.084	.000
	Female	3.033	0.519		
Value of Mathematics	Male	2.434	0.512	-3.416	.001
	Female	2.547	0.515		
Student Competence	Male	2.538	0.628	-2.977	.003
	Female	2.661	0.655		
Teacher Role	Male	2.306	0.630	-2.587	.010
	Female	2.409	0.604		
Cheating Behaviour	Male	2.033	0.880	6.299	.000
	Female	1.701	0.749		

Although both male and female respondents tended to agree and disagree with the same components, there were statistically significant gender differences in most of the dimensions. Performance-Approach Goal Orientation was the only dimension where no statistically significant gender difference was found. In all the remaining dimensions, the female respondents were more positive towards mathematics: They had more powerful mastery orientation, valued mathematics more, felt more competent, perceived their teacher more positively and were less likely to cheat.

## Conclusion and discussion

According to our survey, Estonian university students' generally value mathematics, have both mastery and performance-approach orientation towards their studies in mathematics. They think that knowledge of mathematics is important; it helps them to understand the world. They study mathematics because they know how useful it is. They feel that they are good at mathematics

and are motivated to study mathematics. Those students who have a Mastery Goal Orientation also typically consider themselves to be competent and they also have a positive view of mathematics, want to perform well and have a positive view of their teacher. Moreover, they typically do not cheat.

Students hold a neutral position close to disagreement regarding the Teacher Role suggesting that teacher has not been a specifically important inspirer for most of them. Students' also hold a neutral position close to agreement with Competence. Estonian students think that mathematics is an important subject and most students do not cheat in their studies.

In our study we found that all except one of the aspects of the view seem to have gender differences. These aspects are Mastery Goal Orientation, Value of Mathematics, Student Competence, Teacher Role and Cheating Behaviour. In this study, in most dimensions (five out of six), females have a more positive view of mathematics than male students. The difference between means is not large, but it is statistically significant. Most previous studies in Estonia and elsewhere have indicated that male students have more positive views of mathematics. Our findings in Estonia coincide with those in Canada, where Li (2007) found female students to have significantly more positive attitudes toward mathematics than male students. The present results on gender differences call for a further and more detailed analysis in order to understand the reasons for female Estonian university students' in more positive view towards and higher self-efficacy in mathematics than their male counterparts.

Summarising gender differences in mathematics, we are aware of the fact that our usage of the term "view" is also discussed under the headline of "beliefs" in other literature. Using "view" instead of "beliefs", we want to emphasize that we address motivation in addition to beliefs.

## Acknowledgement

This article was supported unto completion by the European Social Fund.

## References

- Ai, X. (2002). Gender differences in growth in mathematics achievement: Three-level longitudinal and multilevel analyses of individual, home, and school influences. *Mathematical Thinking and Learning*, 4, 1–22.
- Andrews, P., Diego-Mantecón, J., Op 't Eynde, P., & Sayers, J. (2007, February). *Evaluating the sensitivity of the refined mathematics-related beliefs*

- questionnaire to nationality, gender and age*. Paper presented at the working group 2 on affect and mathematical thinking of the fifth European Conference on Mathematics Education, Cyprus. Retrieved June 28, 2011 from <http://www.erne.unito.it/CERME5b/>
- Armstrong, J. M. (1981). Achievement and participation of women in mathematics: Results of two national surveys. *Journal for Research in Mathematics Education*, 12, 356-372.
- Baird, J. S. (1980). Current trends in college cheating. *Psychology in the Schools*, 17, 515-522.
- Brandell, G., Nyström, P., & Sundqvist, C. (2004). *Mathematics – a male domain*. Paper presented at the quadrennial conference of the International Congress on Mathematical Education (ICME 10), Copenhagen, Denmark.
- Fennema, E. (1989). The study of affect and mathematics: A proposed generic model. In D. B. McLeod & V. M. Adams (Eds.), *Affect and Mathematical Problem- Solving: A New Perspective* (pp. 205-219). New York, Springer.
- Fennema, E. (1990). Teachers' beliefs and gender differences in mathematics. In E. Fennema & G. C. Leder (Eds.), *Mathematics and gender* (pp. 169-187). New York: Teachers College Press.
- Fennema, E., & Peterson, P. (1985). Autonomous learning behavior: A possible explanation of gender-related differences in mathematics. In L. C. Wilkinson & C. B. Marrett (Eds.), *Gender influences in classroom interaction* (pp. 17-35). San Diego: Academic Press.
- Fennema, E., & Sherman, J. (1977) Sex-related differences in mathematics achievement, spatial visualisation and affective factors. *American Educational Research Journal*, 14, 51-71
- Finne, L. M. (1996). Gender and mathematics education in Finland. In G. Hanna (Ed.), *Towards gender equity in mathematics education: an ICMI Study* (pp. 155-178). Dordrecht: Kluwer Academic Publishers.
- Forgasz, H. J., Leder, G. C., & Kloosterman, P. (2004). New perspectives on the gender stereotyping of mathematics. *Mathematical Thinking and Learning*, 6(4), 389-420.
- Frost, L. A., Hyde, J. S., & Fennema, E. (1994). Gender, mathematics performance, and mathematics related attitudes and affect: a meta-analytic synthesis. *International Journal of Educational Research*, 21 (4), 373-385.
- Grevholm, B. (1996). Women's participation in mathematics education in Sweden. In G. Hanna (Ed.), *Towards gender equity in mathematics education: an ICMI Study* (pp. 111 - 124). Dordrecht: Kluwer Academic Publishers.
- Hag, K. (1996). Gender and mathematics education in Norway. In G. Hanna (Ed.), *Towards gender equity in mathematics education: an ICMI Study* (pp. 125-137). Dordrecht: Kluwer Academic Publishers.

- Hannula, M. S. (2011). The structure and dynamics of affect in mathematical thinking and learning. In M. Pytlak, E. Swoboda & T. Rowland (Eds.), *Proceedings of the Seventh Congress of the European Society for Research in Mathematics Education* (pp. 34-60). Poland: University of Rzesów.
- Hannula, M. S., Kaasila, R., Laine, A., & Pehkonen, E. (2006). The structure of student teacher's view of mathematics at the beginning of their studies. In M. Bosch (Ed.), *Proceedings of the fourth congress of the European Society for Research in Mathematics Education* (pp. 205-214). Fundemi IQS: Universitat Ramon Llull.
- Hannula, M. S., Maijala, H., Pehkonen, E., & Nurmi, A. (2005). Gender comparisons of pupils' self-confidence in mathematics learning. *Nordic Studies in Mathematics Education*, 10 (3-4), 29-42.
- Hembree, R. (1990). The nature, effects, and relief of mathematics anxiety. *Journal of Research in Mathematics Education*, 21, 33-46.
- Hyde, J. S., Fennema, E., & Lamon, S. J. (1990). Gender differences in mathematics performance: A meta-analysis. *Psychological bulletin*, 107, 139-155.
- Juter, K. (2005). Students' attitudes to mathematics and performance in limits of function. *Mathematics Education Research Journal* (Vol. 17, No. 2. pp. 91-110).
- Kaldo, I., & Hannula, M. S. (2012). Structure of university students' view of mathematics in Estonia. *Nordisk Studies in Mathematics Education* (accepted).
- Kikas, E., Peets, K., Palu, A., & Afanasjev, J. (2009). The role of individual and contextual factors in the development of maths skills. *Educational Psychology*, Vol. 29, No. 5, 541-560.
- Kislenko, K. (2009). Mathematics is a bit difficult but you need it a lot: Estonian pupils' beliefs about mathematics. In J. Maaß & W. Schlöglmann (Eds.), *Beliefs and attitudes in mathematics education: new research results* (pp. 143-164). Rotterdam: Sense Publishers.
- Lam, S., Jimerson, S., Kikas, E., Cefai, C., Veiga, F. H., Nelson, B., Hatzichristou, C., Polychroni, F., Basnett, J., Duck, R., Farrell, P., Liu, Y., Negovan, V., Shin, H., Stanculescu, E., Wong, B. P. H., Yang, H., & Zollneritsch, J. (2011). Do girls and boys perceive themselves as equally engaged in school? The results of an international study from 12 countries. *Journal of School Psychology* (in press).
- Leder, G. (1982). Mathematics achievement and fear success. *Journal for Research in Mathematics Education*, Vol. 13, No. 2, 124-135.
- Leder, G. (1995). Equity inside the mathematics classroom: Fact or artifact? In W. G. Secada, E. Fennema & L. B. Adajian (Eds.), *New directions for equity in mathematics education*. Cambridge University Press.

- Leder, G. C., Forgasz, H. J., & Solar, C. (1996). Research and intervention programs in mathematics education: A gendered issue. In A. Bishop, K. Clements, C. Keitel, J. Kilpatrick & C. Laborde (Eds.), *International handbook of mathematics education, Part 2* (pp. 945–985). Dordrecht, The Netherlands: Kluwer.
- Li, Q. (1999). Teachers' beliefs and gender differences in mathematics: A review. *Educational Research*, 41(1), 63-76.
- Li, Q. (2007). Mathematics, science, and technology in secondary schools: Do gender and region make a difference? *Canadian Journal of Learning and Technology*, 33(1).
- Licht, B. G., & Dweck, C. S. (1987). Sex differences in achievement orientations. In M. Arnot & G. Weiner (Eds.), *Gender and the politics of schooling*. London: Unwin-Hyman.
- McLeod, D. B. (1992). Research on affect in mathematics education: a reconceptualization. In D. G. Grouws (Ed.), *Handbook of research on mathematics teaching and learning* (pp. 575–596). New York, McMillan.
- Murtonen, M., Olkinuora, E., Tynjälä, P., & Lehtinen, E. (2008). Do I Need Research Skills in Working Life?: University Students' Motivation and Difficulties in Quantitative Methods Courses. *Higher Education*, Vol. 56, No. 5, 599-612.
- Norton, S. J., & Rennie, L. J. (1998). Students' attitudes towards mathematics in single-sex and coeducational schools. *Mathematics Education Research Journal*, 10, 16-36.
- OECD (nd). *First results from PISA 2003. Executive summary*. Accessed 12 December, 2006 from: <http://www.oecd.org/dataoecd/1/63/34002454.pdf>
- Op 't Eynde, P., & De Corte, E. (2003). *Students' mathematics-related belief systems: design and analysis of a questionnaire*. Paper presented at the annual meeting of the American Educational Research Association, Chicago.
- Op 't Eynde, P., De Corte, E., & Verschaffel, L. (2002). Framing students' mathematics related beliefs. A quest for conceptual clarity and comprehensive categorization. In G. C. Leder, E. Pehkonen & G. Toerner (Eds.), *Beliefs: A Hidden Variable in Mathematics Education?* pp. 13-37. The Netherlands: Kluwer.
- Pehkonen, E. (1996). Some findings in the international comparison of pupils' mathematical views. In E. Pehkonen (Ed.), *Current state of research on mathematical beliefs III; Proceedings of the MAVI-3 Workshop* (pp. 65-69). Helsinki: University of Helsinki.
- Pehkonen, E., & Törner, G. (1996). Mathematical beliefs and different aspects of their meaning. *ZDM*, 28, 101-108.

- Roesken, B., Hannula, M. S., & Pehkonen, E. (2011). Dimensions of students' views of themselves as learners of mathematics. *ZDM* 43(4), 497-506.
- Schoenfeld, A. H. (1985). *Mathematical problem solving*. Orlando: Academic Press.
- Soro, R. (2002). *Opettajien uskomukset tytöistä, pojista ja tasa-arvosta matematiikassa*. [Teachers' beliefs about girls, boys, and equity in mathematics.], *Annales Universitatis Turkuensis, C* (191). University of Turku. Turku, Finland.
- Sumpter, L. (2009). *On aspects of mathematical reasoning: Affect and gender* (Doctoral dissertation). Umeå University, Department of mathematics and mathematical statistics, Sweden.
- Yusof, Y. B. M., & Tall, D. (1994). Changing attitudes to mathematics through problem-solving. In J. P. da Ponte & J. F. Matos (Eds.), *Proceeding of the eighteenth international conference for the Psychology of Mathematics Education* (Vol. 4, pp. 401–408). University of Lisbon.





## Undergraduate mathematics students' career: a classification tree

CHIARA ANDRÀ, GUIDO MAGNANO AND FRANCESCA MORSELLI

chiara.andra@gmail.com  
University of Torino, Italy

### Abstract

*Starting from a longitudinal survey on the students enrolling in the mathematics undergraduate course at the University of Torino about possible causes of dropout, we analyse in detail the first year of a specific cohort of students: the freshmen in the academic year 2010/11. The purpose of the study is to shed light on the possible factors that can determine success or dropout. We use the methodological tool known as "classification tree", developed within the data mining domain.*

### Keywords

*transition, undergraduate students, dropout, classification tree*

### Life as a trail, decisions as crossroads

The 1998 movie *Sliding doors* draws from the commonly-accepted metaphor of human life as a trail: sometimes there are crossroads and people have to decide where to go. The verb "to decide", indeed, derives from the Latin word *de-caedere* (to cut away): when a certain alternative is chosen, any other possibility is cut away. Similarly, we would like to draw on the trail metaphor for depicting undergraduate mathematics students' careers (either taking the degree or dropping out).

Undergraduate students in mathematics, engineering, and sciences all around the world face several difficulties with mathematics, as it has arisen in UK, Canada, Australia, and Ireland (for a reference of recent researches on this issue see: Rylands & Coady, 2009). The problem is interpreted by Rylands and Coady as a consequence of the undergraduate students' increasingly diverse backgrounds. As a matter of fact, indeed, the variety of high schools from which the students enrolling in mathematics come from is broad and a multifaceted situation is depicted. Although we agree that students enter university with a varied background, for us this is not the final interpretation for the difficulties.

On the contrary, we are interested in detecting the causes of difficulty on which *it is possible to intervene*.

Notice that we are not dealing with generic undergraduate students who have to attend math courses, but rather on with individuals who *specifically chose* undergraduate studies in mathematics. Undergraduate students in mathematics are supposed to be both talented and motivated: they are likely to have experienced a positive causal relationship from attitude to achievement (Ma & Kishor, 1997), as well as from achievement to attitude (Ma & Xu, 2004), in a self-reinforcing sequence of positive experiences—as it has been observed also in other researches, confirming that positive beliefs are related to each other and with positive emotions (Hannula *et al.*, 2006; Roesken *et al.*, 2011). This is likely to involve both the individual and the social aspect of cognition, motivation and emotions (Hannula, 2011).

However, a longitudinal study on undergraduate mathematics students at the University of Torino has shown that each year 20-25% of them dropout after the first academic year (Andrà, Magnano & Morselli, 2012).

Moreover, the aforementioned studies (see Rylands & Coady, 2009) focus mainly on the cognitive aspects in relation to students' difficulties. Also our longitudinal survey has taken into account cognitive aspects, which allowed confirming that dropout students were not necessarily those displaying a significant lack of knowledge at the beginning of university studies. Beliefs and other affective factors, such as motivation, may have a key role in determining difficulties and reaction to them. On the same line, within the MAVI community recent studies have been carried out, focusing on the situation in Spain (Gòmez-Chacòn *et al.*, 2012) and in Germany (Griese *et al.*, 2012).

The purpose of our research is to insert affective factors in a cognitive-oriented assessment test, and to investigate which factors emerge, how they emerge, and to which extent they contribute to understand the dropout phenomenon of undergraduate students in mathematics.

As Goldin (2002) has pointed out, in fact, the cognitive domain includes knowledge, beliefs and memories, i.e. those mental representations to which it makes sense to attribute a truth value, and there exists a synergistic relationship among emotions, cognition and motivation (McLeod, 1992). Among all the possible affect-related factors, indeed, we selected those which have been proved to have some degree of kinship with the students' career: willingness, competence, and performance of behaviors required to cope with transitions (Savickas *et al.*,

2009); and self-efficacy beliefs (Zimmerman & Kitsantas, 2005; Usher & Pajares, 2009). In a previous study (Andrà, Magnano, Morselli, 2012), we have shown that the cognitive-related factors, understood as the outcome of a certain instruction that is measured by certain tools (diploma, test for the assessment of minimum requisites - TARM, exam), or by a combination of them, help explaining success but it does not explain dropout. Both experimental evidence in our longitudinal study and results in literature invite us to consider a combination of cognitive- and affect-related factors in the study of mathematics undergraduate students' career.

A methodological tool that can help us dealing with the students' decision to cut themselves away from the university studies is the classification tree. This tool does not oblige the researchers to assume a linear correlation between the involved variables, a limit that has been pointed out by Hannula (2011) with respect to most researches in the field of affect. As a consequence, it allows us to model the interplay of a large amount of factors without imposing restrictive relations within variables. In the following sections, we first provide a sketchy description of our investigation tools, then we introduce the classification tree methodology, and finally we characterize some profiles.

### The "extended" test: cognitive- and affective-based ITEMS

The issue of transition from secondary school to university is widely discussed in the literature. As regards the observation and the analysis of students' difficulties, Gueudet (2008) notes that researchers may adopt different perspectives, focus on different aspects of the transition issue and, consequently, draw different conclusions, in terms of didactical actions. Researchers may focus: on the different thinking modes that are required at university, as evidenced by all the studies on Advanced Mathematical Thinking (Tall, 1991); on the different organization of knowledge and on the intrinsic complexity of the new contents to be learnt (see for instance Robert, 1998); on the different processes and activities that are at issue, proof for one (Moore, 1994); on the different didactical contract (Bosch *et al.*, 2004) and, more generally, on institutional issues, such as university courses organization (Hoyles *et al.*, 2001). A common feature of these studies is that difficulty in the transition is read in terms of a difficulty for students to adapt to the new context.

Some studies explicitly deal with affective factors in the *transition* issue. For instance, Daskalogianni & Simpson (2001) discuss the concept of "beliefs overhang": some beliefs, developed during schooldays, are carried forward in

university, and this fact may cause difficulties. The study points out the crucial role of beliefs (about mathematics) in determining university success or failure.

In our opinion, affective factors are useful interpretative lenses for understanding the students' choices in terms of either dropout or continuing the university career. Hence, in this study we seek for an intertwining between cognitive- and affective-related factors, which may intervene in dropout/success.

The TARM test (*Test di Accertamento dei Requisiti Minimi*, Test for the assessment of minimum requisites) actually assesses the students' mathematical abilities, but in this study we focus on the students' interpretations of their achievements in mathematics at school. As a first attempt in this direction, in collaboration with Laura Nota (University of Padua) the 2010/11 TARM questionnaire had been enlarged to include a set of items from the *Career Adapt-Abilities Inventory* (Savickas *et al.*, 2009), from the *Perceived Responsibility Scale* (Zimmerman & Kitsantas, 2005) and from the *Source of School Mathematics Self-Efficacy Scale* (Usher & Pajares, 2009). Studies on the view of mathematics and self-beliefs of mathematics learners (Hannula *et al.*, 2005; Roesken *et al.*, 2011) have also been a helpful reference.

Savickas' Career Adaptability is a multidimensional construct that concerns individual differences in the willingness, competence, and performance of behaviors required to cope with transitions. The willingness to engage in the five principal types of coping behaviors that constitute adaptation (orientation, exploration, establishment, management, disengagement) constitute the psychological dimension of the model, and it is composed by the facets of flexibility, proactivity, conscientiousness, and openness. Adapt-ability is the psychosocial dimension and it is distinct from the behaviors that produce adaptation and its outcomes; it includes concern, control, curiosity, confidence, collaboration, and cooperation. Willingness and adapt-abilities shape the individual's readiness and resources for performing the behaviors needed to face vocational development tasks, transitions, or traumas.

For example, we consider the *attitude to think positively about one's professional future* (Adp1), the *curiosity and desire to explore new opportunities, also in the professional sphere* (Adp3), and *self-confidence about one's capacity in fostering professional self-realization* (Adp5). For each scale, the students were given a list of 11 abilities, and they were asked to rate how much they think to have the ability from 1 (very little) to 6 (very much). Examples of abilities are: "to reflect on how my future will be", "to have a positive view of my future", "to prepare for the future", "to become aware of the educational and professional choices I

have to make”, “to advance the changes”, “to be persevering” –as regards Adp1; “to explore my environment”, “to look for opportunities that help me growing up as an individual”, “to consider different ways of doing things”, “to search for information about the choices I have to do”, “to ask for advices” –as regards Adp3; and “to learn from one’s own mistakes”, “to be proud of a well done work”, “to learn new abilities”, “to do things that I consider a challenge”, “to be reliable” –as regards Adp5.

Zimmerman’s and Kitsantas’ Perceived Responsibility Scale assesses individual’s self-efficacy beliefs regarding their use of specific self-regulatory processes in various areas of academic functioning. In our study, the students were given 18 questions concerning the responsibility about school events. They had to rate from 1 (the teacher) to 7 (the student), with the median value 4 corresponding to “both”, whom is responsible for.

Usher and Pajares study self-efficacy beliefs as influenced by four sources: the interpreted result of one’s results, the vicarious experience, the social persuasion, and the emotional and psychological states (mostly anxiety). In our study, the students were asked to rate their level of agreement with each one of 14 statements from 1 (not at all) to 6 (perfectly). One interesting dimension regards the experienced sensations and emotions (Smt4), which is related to the emotional and psychological states. Examples of statements that have been administered to the students are: “the only fact that I have to attend a math lesson makes me feel stressed and/or nervous”, “as I start to make some math exercises I start to perceive sensations of stress”, and “when I think that I have to study math I sag”.

We stress that this is a two-levels paper: at one level, we explore a new method for the analysis of data; at the other level, we present a first analysis of the results on the basis of this new method. As a consequence, also the results reflect this two-level structure, in that they allow us to attempt an answer to the research questions concerning both the “content” (what can we say about first-year undergraduate students?), and the method (what does the analysis made with the decision tree tell us? Can we conclude that this methodology is useful?).

## DATA ANALYSIS

### Methodological considerations

The key concept of data mining is *discovery*, commonly defined as “detecting something new”. The actual data mining task is the exploration of large amounts of data, corresponding to several factors, to extract interesting patterns such as

clusters, unusual records, or dependencies. These patterns can then be seen as a kind of summary of the input data, and used in further analysis. A widespread method in data mining is the *classification tree*, which aims at predicting the value of a target variable on the base of several input variables. The tree is algorithmically constructed (using a computer package) by computing, for each factor to be considered, the information gain (w.r. to the target variable) given by splitting the initial population into two groups at some threshold value. Once found the splitting value which maximizes the information gain, the program explores the next factor, until all factors have been tested. The population is then split according to the factor (and the split value) corresponding to the highest information gain found. At this point, the full process is repeated (including the factor already used for the first splitting) for each of the obtained subgroups, and so on until either (i) each of the resulting subgroups contains only individuals having the same value of the target variable, or (ii) further splitting does not yield significant information gain. The best way to illustrate the method is to show how it works on data, as we shall do in the next section.

### Classification tree construction

Our data cover 162 undergraduate math students at the University of Torino, all enrolled in 2010/11. We shall first consider the number of passed exams (within the first year) as the target variable. In the classification tree construction, the target variable should assume the least possible number of distinct values, to avoid overfitting. Therefore, we had to find a reliable way to “count” the earned credits, then we had to split the range of values at a significant threshold level, so to obtain only two classes for the target variable. Following the 1999 Bologna Accords, European university courses are described in terms of ECTS credits. One ECTS corresponds, in principle, to 25 hours of study; each academic year includes 60 ECTS. In previous studies on math undergraduate curriculum in Turin University, we could observe that a critical ECTS threshold in the first year is 21: students earning less than 21 ECTS in the first year very seldom get the final degree. Accordingly, in the subsequent analysis we shift from description of what happened (number of ECTS earned) to prediction of what is likely to happen (career). Thus, we say that  $ECTS_1 \geq 21$  “predicts success” and, conversely, that  $ECTS_1 < 21$  “predicts dropout”. At the moment, we know also the list of second-year students in 2011/12, and therefore the actual dropout incidence after the first year (a number of students, in fact, give up their studies at a later stage).

We apply the classification tree method to single out which variables “characterize” the two groups ( $ECTS_1 \leq 21$ ,  $ECTS_1 > 21$ ). We have at our disposal up to 27 input variables concerning: personal information that can be read in terms of social

aspects (for instance, living in a big or in a small town, being a commuter and so on); psychological traits and motivations (as emerged from the answers to the “affective” part of the test); data from students’ previous career (diploma grades and type); the performance in the non-selective entrance test (TARM); for each student, we know all scores, credits and examination data for the University first-year courses, but in connection to dropout we considered only the total amount of ECTS obtained in scored exams. The construction of the classification tree is controlled by a number of parameters, such as the list of factors to be used and the minimum information gain to be considered for a split. The “best” model should be a compromise between the maximum overall predictive power and the minimum number of factors and splits needed (a fully predictive tree with too many nodes is likely to be overfitting).

Figure 1 shows a classification tree which gives a correct prediction rate of 92%, using only 9 factors. The variable yielding the greatest information gain is T2, the score in the second part of the test TARM (mostly assessing the comprehension of texts taken from math and physics textbooks, in Italian and in English): the first part of TARM, T1, is the same for all the undergraduate courses in the Faculty of Sciences and assesses basic mathematical skills, while T2 is considered as “specific” for the math curriculum.

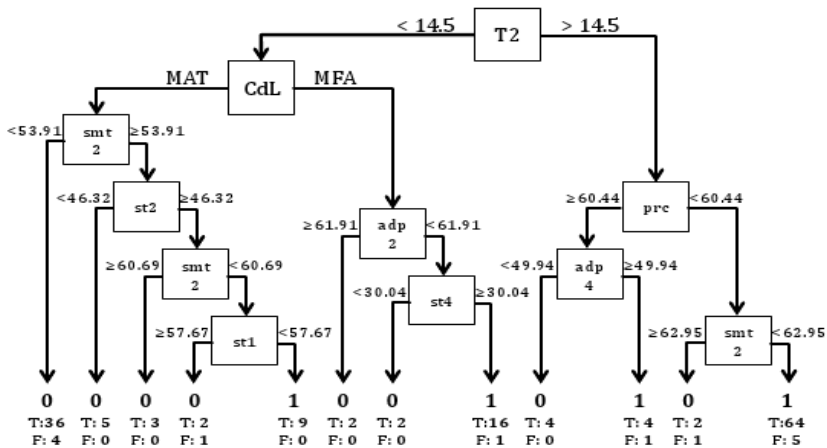

Figure 1. classification tree with ECTS1 as predicted variable.

The T2 score ranges from 0 to 30, and the split value determined by the algorithm (14.5) shows that the test was well balanced. Students on the right branch



(scoring more than 14.5) are subsequently discriminated by “*prc*”, that is *the perceived sense of responsibility* (Savickas *et al.*, 2009): if the latter is not very high ( $prc < 60.44$ ), then the next split is relative to the factor *smt2* (*possibility to observe and imitate effective models*). If  $smt2 < 62.95$ , it predicts “success” ( $ECTS1 > 21$ ). If *prc* is very high, instead, the variable *adp4* (*the ability of establishing positive relationships and cooperating with others*) intervenes. Notice that all measures of affective factors have been rescaled so that  $50 \pm 10$  correspond to the mean  $\pm$  one standard deviation (observed for a suitable reference population).

The digits 0 and 1 at the bottom of terminal branches mean that the tree prediction for that branch is  $ECTS1 < 21$  or  $ECTS1 \geq 21$ , respectively. For each terminal group, we have indicated how many individuals of the original population are correctly classified (“T”), and incorrectly classified (“F”) by the tree.

Going back to the root branching on T2, the variable with the greatest information gain on the left branch (i.e., for students who scored less than 15 in T2) is the undergraduate curriculum: “MAT” (traditional math curriculum) versus “MFA” (applied math for finance and insurance). Here, we are not regarding the choice among the two curricula as an achievement factor: however, this datum should be included because reaching 21 ECTS may have a different significance in the two curricula. It turns out that the difference affects only students with a low T2 score. Among these, MFA students are further classified by variables *adp2* (*inclination to consider oneself as responsible for his own professional future*), and *st4* (*writing ability*). As regards MAT students with low T2, the variable *smt2* plays again a fundamental role.

## Discussion and further developments

We now present the discussion according to the two-levels structure of the paper: we start with some consideration about the “content”, then we continue with the method.

What are we learning from classification trees?

The first branching in each classification tree concerns cognitive variables, then the affective factors emerge. They emerge both for students who are likely to take the degree and for students who are likely to dropout, but in different manners. In fact, for the first group, we observed that a high T2, a not too high *sense of responsibility* (*prc*), and a low *availability of effective models* (*smt2*) predicts “success”. The same variable *smt2* intervenes also when T2 is low, but here it predicts “failure” when it is low. This is a phenomenon which would never be

observed in traditional correlation or multiple regression analysis. Whether this ambivalent (predictive) role of a single factor corresponds to a causal role or not, it is unclear by now. Yet, such phenomena are not manifestly absurd: an excessive sense of responsibility and self-comparison with effective models could actually be negative factors for academic achievement (figure 1); in turn, high adaptability is expected to be a positive factor for academic achievement, but could also lead students experiencing difficulties to decide more easily to change to a different curriculum (adp1 and adp4 in figure 2). Our study, along with Maggiani (2011), confirms that the transition from high school to university is a personal process where –beyond learning skills and motivation– self-beliefs, locus of control and adaptability interact in complex and “nonlinear” patterns, which cannot be explored by traditional correlation analysis.

This should *not* be assumed to describe the actual process which *determines* the academic achievement: it rather indicates that, for instance, students getting a good score in T2 and nevertheless failing to reach 21 ECTS could be *singled out* (with reasonable accuracy) by considering a specific combination of sense of responsibility, previous availability of effective models as a source of mathematical self-efficacy, and adaptability. To relate this *predictive evidence* with a *causal process*, further investigation is required: in particular, one should compare patterns emerging from this exploratory analysis with models proposed by current research on affective factors. For the time being, in fact, we are able to *describe* the sample of interest rather than to show its *predictive power*. We stress that, given both the novelty of the methodology and the specificity of the sample, there are few results in literature that can help us better understanding the phenomenon. However, we hope to have given a contribution in the understanding of students' difficulties.

### The classification tree methodology

The first aspect we bring to light is that in our study we used the results from previous years (since 2001/02) to infer on the present (and the future) students enrolled in the mathematics under graduate course. This implies an overarching assumption: the situation of ten-years-ago students is the same of today's one. The term ‘situation’ has to be meant in a wide way, in order to take into account socio-economical, psychological, and cognitive aspects. Although we are aware of the changes our formative system –as well as our country and our society– had gone through in the last ten years, we claim that some facts are still worthy to be considered. In fact, if we look at the classification tree which contains information about the enrolling to the second year, we can see a confirmation of this.

The methodology of the classification tree can be seen not only as a way to disentangle a complicated (and sometimes contradictory) picture, but also as a generator of research questions – a way to bring into light issues that need further elaboration. It provides the researcher an articulated frame, and the researcher has to make sense of it, without relying on constraining assumptions such as linearity correlations of variables.

We would like to point out that we do not believe that the future of undergraduate students may be completely predicted by means of tests (neither cognitive-based, nor affective-based), or other tools. Our research may serve as a source of information for professors and administrative operators who mind about the students' career, for any reason, to be aware of what is likely to happen in certain circumstances.

#### General considerations on the research

We conclude this paper with some general considerations. The first one concerns the role of the items used to collect data: the picture that emerges from the analysis depends on the data that had been collected. Items are not “neutral” to the research, as well as the assumptions that lay on the background of the methodology used.

Among the items, the affective-based ones have a significant role. As expected, the first split is determined by cognitive factors, but the affective aspects contribute to delineate a varied and multifaceted landscape. Without them, the trees would have stopped after very few steps. In other words, this research contributes to prove that affect-related issues are of crucial importance in the learning processes, considered in a wide perspective.

#### References

- Andrà, C., Magnano, G., & Morselli, F. (2012). Dropout undergraduate students in mathematics: an exploratory study. In B. Roesken & M. Casper (Eds.), *Current state of research on mathematical beliefs XVII. Proceedings of the MAVI-17 conference, September 17-20, 2011* (pp. 13-22). Ruhr-Universität Bochum, Germany.
- Bosch, M., Fonseca, C., & Gascon, J. (2004). Incompletud de las organizaciones matematicas locales en las instituciones escolares. *Recherches en Didactique des Mathématiques*, 24(2-3), 205-250.
- Daskalogianni, K., & Simpson, A. (2001). Beliefs overhang: The transition from school to university. In J. Winter (Ed.), *The Proceedings of the British*

- Society for Research into the Learning of Mathematics*, Vol. 2, (pp. 97-108). Online proceedings, retrieved from <http://www.bsrlm.org.uk/informalproceedings.html>.
- Goldin, G. A. (2002). Affect, meta-affect, and mathematical belief structures. In G. C. Leder, E. Pehkonen & G. Törner (Eds.), *Beliefs: A hidden variable in mathematics education?* (pp. 59-72). Dordrecht: Kluwer.
- Gómez-Chacòn, I., García Madruga, J. A., Rodríguez R., Vila J. O. & Elosúa, R. (2012). Mathematical beliefs and cognitive reflection: do they predict academic achievement? In B. Roesken & M. Casper (Eds.), *Current state of research on mathematical beliefs, XVII Proceedings of the MAVI-17 Conference, September 17-20, 2011*, (pp. 64-73). Ruhr-Universität Bochum, Germany.
- Griese, B., Glasmachers, E., Harterich, J., Kallweit, M. & Roesken, B. (2012). Engineering students and their learning of mathematics. In B. Roesken & M. Casper (Eds.), *Current state of research on mathematical beliefs, XVII Proceedings of the MAVI-17 Conference, September 17-20, 2011*, (pp. 85-96). Ruhr-Universität Bochum, Germany.
- Gueudet, G. (2008). Investigating the secondary-tertiary transition. *Educational Studies in Mathematics*, 67, 237-254.
- Hannula, M. S. (2004). *Affect in mathematical thinking and learning*. Turku, Finland: Annales universitatis Turkuensis B 273.
- Hannula, M. S. (2011). The structure and dynamics of affect in mathematical thinking and learning. In M. Pytlak, E. Swoboda & T. Rowland (Eds.), *Proceedings of the CERME7. Reszow, Poland. 9-13 February 2011*, (pp. 34-60). University of Reszow, Poland: CERME.
- Hannula, M. S., Kaasila, R., Laine, A., & Pehkonen, E. (2006). The structure of student teacher's view of mathematics at the beginning of their studies. In M. Bosch (Ed.), *Proceedings of the CERME4. Sant Feliu de Guixols, Spain. 17-20 February 2005*, (pp. 205-214). Fundemi IQS – Universitat Ramon Llull: CERME.
- Hoyles, C., Newman, K., & Noss, R. (2001). Changing patterns of transition from school to university mathematics. *International Journal of Mathematical Education in Science and Technology*, 32(6), 829-845.
- Ma, X., & Kishor, N. (1997). Attitude toward self, social factors, and achievement in mathematics: a meta-analytic review. *Educational Psychology Review*, 9, 89-120.
- Ma, X., & Xu, J. (2004). Determining the causal ordering between attitude toward mathematics and achievement in mathematics. *American Journal of Education*, 110(May), 256-280.

- Maggiani, C. (2011). La transizione dalla scuola secondaria all'Università: il caso degli studenti del corso di laurea in Matematica. Unpublished manuscript. Tesi di Laurea, University of Genova (Italy).
- Moore, R. C. (1994). Making the transition to formal proof. *Educational Studies in Mathematics*, 27, 249-266.
- Robert, A. (1998). Outils d'analyse des contenus mathématiques à enseigner au lycée et à l'université. *Recherches en Didactique des Mathématiques*, 18(2), 139-190.
- Roesken, B., Hannula, M. S., & Pehkonen, E. (2011). Dimensions of students' views of themselves as learners of mathematics. *ZDM. The International Journal on Mathematics Education*, 43(4), 497-506.
- Rylands, L., & Coady, C. (2009). Performance of students with weak mathematics in first-year mathematics and science. *International Journal of Mathematical Education in Science and Technology*, 40 (6), 741-753.
- Savickas, M., Nota, L., Rossier, J., Dauwalder, J.P., Duarte, M.E., Guichard, J., Soresi, S., vanEsbroeck, R., & van Vianen, A.E.M. (2009). Life designing: A paradigm for career construction in the 21st century. *Journal of Vocational Behavior*, 75(3), 239-250
- Tall, D. H. (1991). *Advanced Mathematical Thinking*. Kluwer, Dordrecht.
- Usher E. L., & Pajares F. (2009). Sources of self-efficacy in mathematics: A validation study. *Contemporary Educational Psychology*, 34, 89-101
- Zimmerman, B. J., & Kitsantas, A. (2005). Students' perceived responsibility and completion of homework: The role of self-regulatory beliefs and processes. *Contemporary Educational Psychology*, 30, 397-417

## Why Johnny fails the transition

FULVIA FURINGHETTI, CHIARA MAGGIANI AND FRANCESCA MORSELLI

furinghe@dima.unige.it

Department of Mathematics, University of Genova, Italy

### Abstract

*This paper reports on a research project concerning the difficulties met by students in mathematics during the first year of university. The combination of different analytical tools (questionnaires, interviews, problem solving and proof activities allowed to shed light on aspects of transition which are not purely cognitive, but also pertain to the affective domain.*

### Key words

*transition, students' difficulties, false continuity, proof.*

### Introduction

This paper treats the problem of the transition from secondary school to university. Gueudet (2008) identifies two main lines of research on the topic of transition: detecting students' difficulties and planning interventions for making the transition easier. The study reported in the present paper belongs the first line of research, with reference to undergraduate students in mathematics. The students who choose to enroll in an undergraduate mathematics course are aware that their curriculum will be mainly based on mathematics. Hence, we may assume that they are motivated in regard to this discipline or, at least, they have not negative feelings about it. We add that, in general, at secondary school they have been good students. Nevertheless, data from the University of Genova referring to the academic years from 2001-2002 to 2008-2009 reveal that around 24% of the enrolled students give up after the first year. Our study aims at understanding what "goes wrong" in the transition from secondary school to university. Thus, our questions are:

- Who are the students entering the first year? What is their "story"? What are their preceding experiences with mathematics?
- What happens during the transition? How do students perceive the transition?

As we'll detail in the following sections, we choose to explore these issues adopting a theoretical perspective according to which cognitive and affective factors are strongly interrelated. Hereunder we point out some basic features of our study:

- *Different analytical tools for analyzing different data.* As we'll show in the section "Methodology", we perform our analysis on three kinds of data: questionnaires, interviews, written individual solutions of problem solving tasks. These data are analyzed by means of analytical tools coming from different fields of the research in mathematics education.
- *Focus on proof.* As we'll discuss in the section "Theoretical framework", the way of dealing with proof is a crucial divide between secondary and tertiary mathematics education. Thus, in our study the analysis of students' proving processes will have a central role.
- *Long-term study.* Data were collected at different moments of the first year.

For space constraints, in the present paper we confine ourselves to the description of the methodology and to the discussion of some results from the analysis of the data referred to a convenient sample. For a full account of the study see (Maggiani, 2011).

## Theoretical framework

As observed by Clark and Lovric (2008) any transition from a school level to another presents problems for students. As regards mathematics, these problems are particularly marked in the secondary-tertiary transition because most students experience for the first time working in the axiomatic-formal world, see (Tall, 2008). As Tall (1992) put it, students are required to pass:

*from a position where concepts have an intuitive basis founded on experience, to one where they are specified by formal definition and their properties reconstructed through logical deductions. (p. 495)*

In the teaching practice the requests made to the learners change accordingly, as stressed by Tall (1997):

*At school the accent is on computations and manipulation of symbols to "get an answer", using graphs to provide imagery to suggest properties. At university there is a bifurcation between technical mathematics that follows this style (with increasingly sophisticated techniques) and formal mathematics, which seeks to place the theory on a systematic, axiomatic basis. (p. 9)*

The cognitive aspect outlined by Tall is present also in the work of many authors, who studied the secondary–tertiary transition or undergraduates’ difficulties. Ferrari (2004) focuses on the problem of language in advanced mathematical thinking. Moore (1994) examines the cognitive difficulties that university students experience in learning to do formal mathematical proofs. Castela (1995) and Praslon (1999) analyze the ways the same subject (tangent for Castela and derivative for Praslon) is presented at school and university and the consequent cognitive ruptures. Robert (1998) considers the different organization of knowledge and the complexity of the new contents. Some studies, such as (Di Martino & Maracci, 2009) and (Zan, 2000), pay a particular attention to affective factors. Ward-Penny, Johnston-Wilder, and Lee (2011) investigate about undergraduates’ disaffection for mathematics with reference to the construction of their mathematical identities and self-efficacy.

Other authors focus on aspects more linked to the context: didactic contract (Bosch, Fonseca, & Gascón, 2004), the influence of social phenomena (De Guzmán, Hodgson, Robert, & Villani, 1998), the institutional problems linked to the organization of the courses (Hoyles, Newman, & Noss, 2001), or the way university examinations in mathematics are carried out (Griffiths & McLone, 1984a; 1984b).

A main point in the difference of teaching style between school and university is the big amount of time dedicated to proof in university courses. As an example we cite the case of the lectures of three mathematics professors reported in (Mills, 2011): roughly half the lecture time was dedicated to present proofs. Mathematics educators such as Dreyfus (1991) as well as mathematicians such as Thurston (1994) and Davis and Hersh (1981) claim that mathematics is often presented to students in a definition-theorem-proof format. This presentation emphasizes one of the role of proof, that of convincing students that an assertion is true. But, as De Villiers (1990) points out, other roles of proof are important in mathematics classroom, such as explaining why an assertion is true, exploring new situations, and promoting communication. In his investigation about mathematicians’ perspectives on their pedagogical practice with respect to proof, Weber (2012) reports that: on one hand, there is a large consistency between mathematicians’ and mathematics educators’ goals for presenting the different roles of proof; on the other hand, the participants to the study “appeared to lack an arsenal of pedagogical strategies to achieve their goals” (p. 478).

In light of the concerns outlined above, we chose proof as a pivotal element for dealing with the issue of transition. As a matter of fact, in the paper we consider the beliefs on transition put forward by students and afterwards we analyze



their performances in activities of problem solving and proving with the aim of disentangling the interplay between the activities of mathematizing (talking about mathematical objects) and of identifying (talking about participants of the discourse), see (Heyd-Metzuyanım & Sfard, 2012).

## Methodology

In order to deal with the aforementioned questions we carried out a qualitative research, see (Patton, 1990) that developed according to the following steps:

- administration of a questionnaire to the students enrolled in the first year of the university program in mathematics (50 students); see below for a presentation of the questionnaire;
- identification of a sample of nine students on which to focus our investigation;
- a first audio-recorded interview to a sample of students, in order to deepen the themes of the questionnaire;
- written individual problem solving activity performed by the sample students;
- second audio-recorded interview concerning the written individual problem solving activity;
- third audio-recorded interview to the sample, at the end of the year, for a sort of concluding outlook.

At the University of Genoa the academic year starts in October. We collected data from November 2010 to May 2011, in order to have a global panoramic of students along the first year of university. As the previous list points out, a peculiarity of our work is the combination of different research instruments (questionnaires, interviews, etc.). Table 1 summarizes the steps of the data collection and the schedule of the university examinations so as to link the steps of our research with the academic life of the students.

The questionnaire was administered at the beginning of the academic year (around one month after the beginning of the courses). The aim was twofold: gathering data on the whole population and select a sample for the in-depth interviews and the problem solving activity. The first part of the questionnaire, designed by a commission appointed by the Mathematics Department, is administered every year to the freshmen. The second part of the questionnaire was explicitly designed and administered by one of the authors (C. M.) for the purpose of the research. The students were informed about the project they were involved in.

The first part of the questionnaire contained multiple-answer questions on the attended secondary school, the motivations for the choice of the university program, the possible role of orientation activities proposed by university in such a choice, expectations and satisfaction about the university program, attendance to tutorial activities, suggestions to improve activities for secondary students aimed at orienting in the choice of the university career.

The second part of the questionnaire contained open-answer questions and Likert scale questions concerning students' previous university studies (if any), orientations for work after university, the most and the least favorite topics in mathematics at secondary school level, relationship to proof in secondary school, evaluation (in term of Likert scale) of some factors for success in mathematics. Furthermore, we asked students to narrate their own story with mathematics.

*Table 1. The steps of the data collection and population (third column) and the schedule of the academic examinations (second column).*

<i>Date</i>	<i>Academic examination</i>	<i>Data collection</i>
November, the 2nd		Questionnaire (50 students)
November, 15-19	Intermediate examinations (algebra, infinitesimal analysis)	
November, 22-30		Interview n. 1 (sample)
December, the 6th		Problem solving (sample)
December		Interview n. 2 (sample)
January-February	Intermediate examinations (algebra, analysis) and mid-term examinations (algebra, analysis, mathematical laboratory)	
April, 28-29	Intermediate examinations (physics, probability)	
May, 2-18		Interview n. 3 (sample)

After the administration of the questionnaire, we chose a sample of nine students among those who had declared their willingness to take part in the research project. Criteria for the choice were the kind of secondary school they attended (e.g., secondary school with strong scientific orientation, with humanistic orientation and so on), their declared intentions about the future job and the answer to the question concerning factors for success in mathematics. In addition, we selected students coming from different secondary institutes and no commuter students, so as to work with students who should have more time at disposal for the additional activities we proposed.

The first semi-structured interview to the sample took place in November. Themes of the interview were: the preparation offered in secondary school in order to face university, first course examinations, factors for success in mathematics, expectations and satisfaction about the university program, (possible) difficulties and strategies to overcome them, proofs (with particular reference to the difference between proofs in secondary schools and proofs at university level). Often there have been questions concerning future job, (possible) influence of parents, friends, teachers or events on the choice of the university program. Some answers to the questionnaire were also discussed during the first interview.

The third step (developed in December) concerned individual problem solving activity. The students of the sample were proposed five problems, three of which were proving activities. The five problems were given at the same time, and each student could choose the order of resolution. The students solved the problems individually. There was no time limit. They were asked to write down, as much as possible, also their emotions, ideas, etc. This request, unusual for the students, was aimed at leading them be reflective about their way of working.

In the subsequent days, one of the researchers (C. M.) carried out individual retrospective interviews on the solving processes. The interviewed students were invited to reconstruct verbally the solving process; in case of mistakes or incomplete solutions, they could amend or complete the solution, autonomously or with the help of the interviewer. During the interview the students were encouraged to discuss the emotions experienced during the solving process.

The last individual semi-structured interview took place in May. The themes of the interview were: examinations already taken during the academic year (expectation and difficulties, strategies to pass them, results), feelings about the choice of the university faculty (regret, satisfaction, surprise, etc.), possible changes in the relationship to mathematics, possible changes in the job intention, general comments about the participation to the research project.

## Findings

The analysis of the first interview, combined with the answers to the questionnaire, gives an insight into the students' views about the passage from secondary school to university. The analysis of the problem solving performances, which included proofs, gives information on the way students deal with a key activity in their university experience.

### *Students' views about transition*

We coded the answers to the questionnaire and to the first interview along these factors (inherent of the transition from secondary school to university):

- the importance of school background (scientific orientation vs. non-scientific orientation);
- differences between school and university (new ways of teaching and learning: faster introduction of new concepts, need for more autonomy, study for the written tests, time managing during written tests);
- differences between school mathematics and university mathematics (advanced mathematical thinking, symbols, language, proof).

As mentioned in the methodology section, the students of the sample come from secondary schools with different orientations. The students who studied in a secondary school with scientific orientation, generally deem that secondary school gave them a good preparation in terms of knowledge. Nevertheless, they point out that the transition to university is somehow problematic for them, since mathematics is presented in a different way and the organization of the university activity is different from that of school. We may say that their initial feeling of continuity is transformed into "false continuity".

Gogear points out the difference between secondary school mathematics and university mathematics, which is, in his opinion, a matter of different approach:

*If I had difficulties, it wouldn't be my secondary school's fault, since at secondary school you do so much different things, the approach is totally different. If I have difficulties, it's my fault.*

Since the approach is totally different, according to Gogear the cause of difficulties or failures is not on the lack of preparation in secondary school, but in himself (internal causal attribution, Weiner, 1985).

Louis claims that a source of difficulty comes from his need of visualizing concepts, as he was used to do in secondary school:

*The work [in secondary school] was more geometrical. For instance, they said: that's a derivative. [...] We just studied limits. I was used to seeing limits in a geometric way. I understand them because I see them in that way. I see the incremental ratio and so on. While here [at university] we have only formulas [...]. It is very hard to see, to imagine what is a derivative. [...] I don't like matrices, because I see tables of numbers to be multiplied in a strange way, I don't see what they are in reality.*

Following the model of the three worlds used in (Tall, 2008) to illustrate the cognitive development in mathematics we may say that Louis's words express the difficulties of the transition secondary–university in term of difficulties in progressing from the conceptual-embodied to the axiomatic-formal worlds.

Significantly different is the situation of those students who studied in a secondary school with a non-scientific orientation (humanistic orientation and so on). All these students feel their former preparation to be inadequate for university studies in mathematics. For instance, Meg points out that other students, coming from a secondary school with scientific orientation, seem quite “at ease”, because they already studied infinitesimal analysis and so on. On the contrary, there are concepts she never met.

### Proof

Some students did not worked on proofs at all in secondary school, while other students already met proofs. All the students point out that proof is central in university mathematics. A source of difficulty is the fact of having to produce proofs by themselves, rather than reproducing them as they used to do at school.

In order to deepen our understanding of students' relationship to proof, three of the five tasks proposed to the students of the sample concerned proof. In the present section we present some findings from the following task:

*Prove that, if  $x$  and  $y$  are two odd natural numbers, and they are not both equal to 1, then  $x^2+y^2$  is not a prime number.*

Four students carried out an algebraic proof, “pushing symbols”. Two students proved by means of natural language. One student, Sara, alternates symbols and natural language. Another student, Cucky, started using symbols, but after

a while gave up and showed a numeric example. Another student, Paola, used symbols without succeeding. Two students planned to prove by contradiction, but did not succeed, one student claimed to use the proof by contradiction, but, indeed, carried out direct proof.

The students were asked to write down, as much as possible, also the emotions and thoughts that accompanied their solving process. Although not all the students were able or were willing to do that, the written documents provide information that goes beyond the pure cognitive and it will be better analyzed through the tools presented in (McLeod, 1992). We may distinguish between “preliminary comments”, generated before starting the solving process, and “ongoing comments” generated during the process when the students met a moment of difficulty or impasse and wrote down their emotions associated to this moment. Students’ beliefs emerge in terms of insights on students’ self-confidence and self-efficacy provided by preliminary comments, and from the traces of causal attribution detected in the ongoing comments.

With regard to the “preliminary comments” Sara wrote down at the very beginning: “*Ok that’s easy*”. Afterwards, she carried out the proof without problems. Analogously, Ro started by writing: “*My mood in front of the problem is quiet and I decide to start with an [numeric] example*”. Both comments reveal a good self-confidence that makes the approach to the proof smooth.

Totally different is the first comment by Meg, who, after having written down hypothesis and thesis, wrote down: “*Panic! I hate proving!*”. Afterwards, she started reflecting on the text, but, being her approach driven by a low self-confidence, she seems to be looking for possible causes of difficulties rather than for a real comprehension of the text. This intertwining between affective and cognitive factors resounds the findings in (Furinghetti & Morselli, 2009) about the proving process carried out by mathematics students of the final year. The present study shows that such an intertwining is present already at the beginning of university studies.

With regard to the “ongoing comments”, we report on different situations hinted by the performances by Sara, Ro and Meg.

Ro, as already reported, started with a numeric example: she chose two odd numbers, 3 and 5, and computed  $x^2+y^2=3^2+5^2=34$ . Afterwards, at first she wrote down “*This is a counterexample*”. This last sentence was erased and Ro wrote: “*I was absent minded and made a great mistake! 34 is not a prime number ...*”. We think it is interesting the causal attribution performed by Ro: she made a mistake

because she was “*absent minded*”. This is an internal and controllable cause. We found other occasions in which Ro resorted to internal causal attribution, e.g. she claimed that she did not pass the examinations because “*she did not study enough*” (excerpt from the third interview).

After having written down the starting point of the proof by contradiction, Meg claimed: “*Logically, it is obvious that the thesis is true. I mean, intuitively I would say: of course! But proving is always a problem!*”. This sentence shows that proving is not a problem of being convinced of the trueness of the statement, but a problem of knowing the techniques of proving.

Some proving processes evidence problems in dealings with algebraic symbols, as evidenced by Sara’s difficulty in recognizing the equation of a parabola because the variables were not labeled as  $x$  and  $y$ . Referring to the model of cognitive development in (Tall, 2008), the persistence of the problems with symbols suggests that students have difficulties not only to reach the third the axiomatic-formal world is a problem, but also to work in the second world (proceptual-symbolic). Moreover, not all students were able to pass from a register to another: only the good solvers showed flexibility in working with the algebraic language and with verbalization. This flexibility mirrors the capacity of giving meaning to the algebraic language going beyond a pure syntactic approach by seeing processes as a whole and compressing operations into thinkable concepts (Tall, 2008). As already stressed in (Furinghetti & Morselli, 2009), the low flexibility may be linked to the belief on algebra seen as an automatic proof generator.

## Discussion

The findings from the interviews show that students perceive a break in the transition between secondary and university level. We found two types of break and different types of interpretations given by students. The types of break are linked to the differences in students’ mathematics preparation in secondary school (scientific vs. non scientific orientation). As for students with scientific background the break concerns the approach to mathematics: the supposed continuity, which is based on the fact that they already met certain topics and did a lot of mathematics, is actually a “false continuity” that may cause difficulties. Students point out that, in comparison with secondary school mathematics, university mathematics is less procedural. Furthermore, the concepts already studied in secondary school are presented in a different, more theoretical and rigorous way:

*In infinitesimal analysis, I thought: I already studied this at secondary school, so I don't need to study it a lot, because I already know it ... but this is not true. Thus, I had to change my mind. (Deste)*

If the students who come from a school with scientific orientation do not realize that the continuity is only at content level, they will encounter further difficulties. The causal attributions put forwards by Luis and Gogear reported before show different interpretations of the changes. Luis is able to identify specific aspects characterizing the new approach, while Gogear remains confined to his personal problems.

The students coming from secondary school with no scientific orientation feel the break in terms of ignoring completely some mathematical topics (that were not present in their secondary school curriculum). These students, feeling that they have not sufficient “background” for advanced studies in mathematics (see the case of Meg) may be decided to give up. On the contrary, students who attended a secondary school with scientific orientation tend to assume that their background is sufficient and interpret the (unavoidable?) difficulties linked to transition in terms of different approach, need for a different method of study, personal deficiencies and so on. Referring to the theory of causal attribution (Weiner, 1985) we may say that the students from secondary school with scientific orientations interpret failure and difficulty in terms of internal causal attribution (*I must change my approach*), while students from non-scientific oriented schools attribute their difficulty to the kind of the secondary school, the teacher or other external causes. An internal causal attribution is often perceived as controllable, that is to say students feel it is their own responsibility to change, while an external causal attribution is often felt as “without possibility of remedial”.

Referring to the functions of proof described by De Villiers (1990) (verification/conviction, explanation, discovery, systematization, communication), we may say that the students point out mainly the function of explanation, as evidenced in Luis's answer to the questions of the questionnaire “*Did you enjoy doing proofs in secondary school? Did you find doing proofs useful? Why?*”:

*I found useful to prove facts that were not evident, because such facts become simpler when you see the causes. On the contrary, proving intuitive facts risks to be confusing (Luis).*

This answer evidences that perceiving the function of explanation as the only function of proof may have the dangerous consequence, since proof is carried out to explain, students often feel that proving something “obvious” or evident is



useless. Luis's sentence reveals that the student is not completely at ease with the advanced mathematical thinking:

Finally, we note that the presence of many internal causal attributions, both in interview and proving activities, may be interpreted as a symptom of an acceptance of the way of teaching in mathematics department as appropriate, even when it clearly is problematic for many of the students. In the mathematical discourse there is no devolution of authority from the teacher to students, see (Lampert, 1990).

## Conclusions

The integration of different analytical tools, allowed investigating on how students live the transition exploiting the different potentialities of questionnaires, interviews, and problem solving/proof.

From the acknowledgement that proof is the core of university course in the mathematics program it followed that an investigation on the transition from secondary school to university has to be focused on proof. On the other hand, as we have experienced in previous works such as (Furinghetti & Morselli, 2011), proof is the gateway towards the set of abilities, knowledge, behaviors, and beliefs that drive an individual's mathematical activity. The way students cope with proof is an important means for studying how they enter into the mathematical discourse. Our study confirms that students' process of proving not only relies on beliefs about mathematics, in particular about the approach to advanced mathematical thinking, but also generates hot feelings affecting self-confidence and self-efficacy which are factors interfering in the mathematical discourse.

The reported excerpts reveal the persistence of certain beliefs coming from secondary school, as a part of the students' concept images, see (Tall & Vinner, 1981). Luis's struggle in entering into the third world (axiomatic-formal) was linked to the intuitive/perceptual aspect of visualization. Sara's hesitation in the process of proving was due to the stereotypes on the algebraic representations and symbols in her concept image. As emerged from some students' words reported in the previous sections, the concepts image of proof itself was largely inherited by the secondary school experience and not modified by the first university courses.

All that said, though our research was aimed at detecting students' difficulties, we deem that the activities we proposed have some potentialities for meeting students' needs in the process of transition, as epitomized by Sara's sentence:

*[Participating in the research] forced me to reflect on such things; all those questions about the reason, how I feel, my method of study... maybe usually you don't even think about it. But if you are forced, you must focus on it.*

## Acknowledgments

We thank Markku Hannula, Indrek Kaldo, and Nathalie Sinclair for their precious comments to the preliminary version of our paper.

## References

- Bosch, M., Fonseca, C., & Gascón, J. (2004). Incompletud de las organizaciones matematicas locales en las instituciones escolares. *Recherches en Didactique des Mathématiques*, 24(2–3), 205–250.
- Castela, C. (1995). Apprendre avec et contre ses connaissances antérieures: un exemple concret, celui de la tangente. *Recherches en Didactique des Mathématiques*, 15, 7-47.
- Davis, P. J., & Hersh, R. (1980). *The mathematical experience*. Boston: Birkäuser.
- De Guzmán, M., Hodgson, R. B., Robert, A., & Villani, V. (1998). Difficulties in the passage from secondary to tertiary education. In G. Fischer, & U. Rehmann (Eds.), *Proceedings of the International Congress of Mathematicians. Documenta Mathematica, Journal der Deutschen Mathematiker-Vereinigung*, Extra volume ICM 1998 (Vol. 3, pp. 747-762).
- De Villiers, M. (1990). The role and function of proof in mathematics. *Pythagoras*, 24, 7-24.
- Di Martino, P., & Maracci, M. (2009). The secondary-tertiary transition: beyond the purely cognitive. In M. Tzekaki, M. Kaldrimidou & H. Sakonidis (Eds.), *Proceedings of PME 33* (Vol. 2, pp. 401-408). Thessaloniki, Greece: PME.
- Dreyfus, T. (1991). Advanced mathematical thinking processes. In D. Tall (Ed.), *Advanced mathematical thinking* (pp. 25-41). Dordrecht: Kluwer.
- Ferrari, P. L. (2004). Mathematical language and advanced mathematics learning. In M. Johnsen Høines & A. Berit Fuglestad (Eds.), *Proceedings of PME 28* (Vol. 2, pp. 383-390). Bergen: Bergen University College.
- Furinghetti, F., & Morselli, F. (2009). Every unsuccessful solver is unsuccessful in his/her own way: affective and cognitive factors in proving. *Educational Studies in Mathematics*, 70, 71-90.
- Furinghetti, F., & Morselli, F. (2011). Beliefs and beyond: hows and whys in the teaching of proof. *ZDM, The international Journal on Mathematics Education*, vol. 43, 587-599.

- Griffiths, H. B., & McLone, R. R. (1984a). A critical analysis of university examinations in mathematics. Part I: A problem of design. *Educational Studies in Mathematics*, 15, 291-311.
- Griffiths, H. B., & McLone, R. R. (1984b). A critical analysis of university examinations in mathematics. Part II: A problem of evaluation. *Educational Studies in Mathematics*, 15, 423-442.
- Gueudet, G. (2008). Investigating secondary-tertiary transition. *Educational Studies in Mathematics*, 67, 237-254.
- Heyd-Metzuyanım, E., & Sfard, A. (2012). Identity struggles in the mathematics classroom – learning mathematics as an interplay between mathematizing and identifying. *International Journal of Educational Research*, 51-52, 128-145.
- Hoyles, C., Newman, K., & Noss, R. (2001). Changing patterns of transition from school to university mathematics. *International Journal of Mathematical Education in Science and Technology*, 32, 829-845.
- Lampert, M. (1990). When the problem is not the question and the solution is not the answer: mathematical knowing and teaching. *American Educational Research Journal*, 27(1), 29-63.
- Maggiani, C. (2011). *La transizione dalla scuola secondaria all'università: Il caso degli studenti del corso di laurea in matematica*. Unpublished Dissertation Laurea Magistrale. University of Genova.
- McLeod, D. B. (1992). Research on affect in mathematics education: a reconceptualization. In D. A. Grouws (Ed.), *Handbook of research on mathematics learning and teaching*. (pp. 575-596). New York, NY: Macmillan.
- Mills, M. (2011). Mathematicians' pedagogical thoughts and practices in proof presentation. In S. Brown, S. Larsen, K. Marrongelle, & M. Oehrtman (Eds.), *Proceedings of the 14th Conference for Research in Undergraduate Mathematics Education* (Vol. 2, pp. 283-297). Portland, OR.
- Moore, R. C. (1994). Making the transition to formal proof. *Educational Studies in Mathematics*, 27, 249-266.
- Patton, M. Q. (1990). *Qualitative evaluation and research methods (2nd edition)*, Newbury Park, CA: Sage Publications.
- Praslon, F. (1999). Discontinuities regarding the secondary/university transition: the notion of derivative as a specific case. In O. Zaslavski (Ed.), *Proceedings of PME 23* (Vol. 4, pp. 73-80). Haifa: The Technion Printing Center.
- Robert, A. (1998). Outils d'analyse des contenus mathématiques à enseigner au lycée et à l'université. *Recherches en Didactique des Mathématiques*, 18(2), 139-190.
- Tall, D. (1992). The transition to advanced mathematical thinking: functions, limits, infinity and proof. In D. A. Grouws (Ed.), *Handbook of research*

- on mathematics teaching and learning* (pp. 495-511). New York, NY: Macmillan.
- Tall, D. (1997). From School to University: the effects of learning styles in the transition from elementary to advanced mathematical thinking. In M. O. J. Thomas (Ed.), *Proceedings of The Seventh Annual Australasian BridgingNetwork Mathematics Conference* (pp. 9-26). Auckland: University of Auckland.
- Tall, D. (2008). The transition to formal thinking in mathematics. *Mathematics Education Research Journal*, 20(2), 5-24.
- Tall, D., & Vinner, S. (1981). Concept image and concept definition with particular reference to limits and continuity. *Educational Studies in Mathematics*, 12, 151-169.
- Thurston, W. P. (1994). On proof and progress in mathematics. *Bulletin AMS*, 30, 161-177.
- Ward-Penny, R., Johnston-Wilder S., & Lee, C. (2011). Exit interviews: undergraduates who leave mathematics behind. *For the Learning of Mathematics*, 31(2), 21-26.
- Weber, K. (2012). Mathematicians' perspectives on their pedagogical practice with respect to proof. *International Journal of Mathematics Education in Science and Technology*, 43, 463-475.
- Weiner, B. (1985). An attributional theory of achievement motivation and emotion. *Psychological Review*, 92, 548-573.
- Zan, R. (2000). A meta cognitive intervention in mathematics at university level. *International Journal of Mathematical Education in Science and Technology*, 31(1), 143-150.



# Conceptions of research and of being a researcher among mathematics education doctoral students

ÇİĞDEM HASER AND ERDİNÇ ÇAKIROĞLU

chaser@metu.edu.tr

Middle East Technical University, Turkey

## Abstract

*Mathematics education doctoral students' conceptions of research and of being a researcher were investigated within the context of a workshop for their career plans. Analysis of data from 10 doctoral students' responses to open-ended questionnaire and discussions in the workshop revealed that research should address solving problems or addressing gaps, in order to improve the quality of mathematics instruction in schools and inform stakeholders. Research should produce valid, reliable, significant, and applicable results for the field. Mathematics education researcher was responsible for conducting ethical research for the society and should have knowledge and critical skills of mathematics education and research. Findings addressed context specific nature of conceptions*

## Keywords

*mathematics education doctoral students, conceptions of research*

## Introduction

A recent increase in the number of mathematics education doctoral programs in Turkey has mostly been the result of the faculty development efforts for newly established public universities. The majority of doctoral students are expected to work at these public universities after their graduation (Ubuz, Çakiroğlu, & Erbaş, 2011) and bring their conceptions of teaching, learning, and research to the mathematics education programs at these universities. Such conceptions are likely to reflect their experiences as graduate students as well as the specific discipline or field of study they have been involved (Stubb, Pyhältö, & Lonka, 2012) and have the potential to influence their future careers. The present study investigated mathematics education doctoral students' conceptions of research and of being a researcher within the context of the field of mathematics education through a workshop designed for doctoral students. We were interested in how their research experiences were reflected in their beliefs, meanings, mental images,

and ideas as contextualized in the field of mathematics education. It is widely accepted that one of the important indicators of effectiveness of teacher education programs is preservice teachers' beliefs (Richardson, 1996). Similarly, we believe that conceptions of doctoral students could be the indicators of outcomes of the doctoral programs. Our intention is to gain feedback from doctoral students in terms of their conceptions in order to initiate more grounded opportunities of career development for future mathematics education researchers.

## Conceptions of research and researcher

Conceptions, in the mathematics education research, address a mental structure including beliefs, concepts, mental images, and meanings (Philipp, 2007). Most of the studies on doctoral students' conceptions do not provide much information on how they refer to the construct of 'conceptions.' Meyer, Shanahan, and Laughksch (2005) state the conceptions of research as "reflected as (variation in) the contextualized beliefs, ideas, or understandings of postgraduate students who are actually engaged in various forms of research" (p.227).

Meyer (2007) addressed that postgraduate research was a learning process. In this process, new knowledge was created through an interaction of research processes and prior knowledge of research, which were influenced by conceptions of research. He stated that while research processes addressed generic or discipline-specific elements within the production of research, prior knowledge of research included the ways of creation of a new knowledge in the discipline. This prior knowledge of research, in turn, influenced conceptions of research when individuals were involved in the research process. Therefore, conceptions of research were likely to be context and/or discipline specific because of the specific research processes and prior knowledge of research (Meyer, Shanahan, & Laughksch, 2005; Stubb, Pyhältö, & Lonka, 2012).

Research on conceptions of research has focused on undergraduate and graduate students, doctoral supervisors, and senior researchers and has employed qualitative and quantitative approaches in a wide array of disciplines and fields. The most widely expressed conceptions have been knowledge orientated in terms of gathering, exploring, discovering, or validating knowledge as well as problem solving (Akerlind, 2008; Brew, 2001; Meyer, Shanahan, & Laughksch, 2005; Pitcher, 2011; Stubb, Pyhältö, & Lonka, 2012). Research has also been conceptualized as a personal journey where researchers have investigated their interests and developed own understandings (Akerlind, 2008; Brew, 2001; Stubb, Pyhältö, & Lonka, 2012) or as a job to do especially by doctoral students in natural sciences or medicine (Stubb, Pyhältö, & Lonka, 2012). Conceptions of being a

researcher, on the other hand, have received less attention among researchers. Being a researcher was conceptualized among academics from a wide range of research areas as fulfilling academic requirements, establishing oneself in the field, developing oneself personally, and enabling a broader change (Akerlind, 2008). These conceptions seemed to be parallel to the conceptions of research stated earlier.

The stated conceptions of research and of being a researcher, however, have not specifically addressed conceptions of doctoral students studying in the field of mathematics education. Doctoral students have relatively shorter duration of research experience and are still considered in the process of developing conceptions of research and of being a researcher in the field of mathematics education. Understanding conceptions of research and of being a researcher may provide a baseline for training programs focusing on researcher skills such as developing critical thinking and multiple perspectives, and distinguishing between judgments based on evidence or speculation (Meyer, Shanahan, & Laugksch, 2005).

Doctoral students' conceptions are likely to reflect the research context they work in. An analysis of completed dissertations and theses in the field of mathematics education in Turkey has revealed that more than half of the graduate research in the last decade focused on issues of teaching mathematics, learning mathematics, methodological issues, mathematics teacher education, and mathematics curriculum (Baki, Güven, Karataş, Akkan, & Çakıroğlu, 2011) supervised by mathematics education researchers with mathematics or mathematics education background (Sriraman, 2010). Therefore, Turkish mathematics education doctoral students' conceptions are likely to be influenced by these past studies, the local and national research context, and their supervisors' research fields and priorities.

## Methodology

### Context

The study was conducted in the context of the doctoral program in Elementary Education focusing on issues of teaching and learning at all levels in the fields of mathematics, science, and early childhood education. Students with related backgrounds can pursue their studies in this program either after getting a Master's degree by taking 21 credits or a B.S. degree (integrated program) by taking 42 credits. The program required students with Master's degree to take an advanced course on research methodologies and dissertation credits in addition



to five elective courses. Students without Master's degree should also take research methodologies, statistics, and seminar courses. Doctoral students pass a doctoral comprehensive examination (which is administered twice a year – May and November) after or during the completion of their coursework within the first five semesters. They defend their doctoral dissertation proposal six months after they pass the examination to a dissertation committee and report their progress to this committee every six months. They defend their dissertation to their doctoral dissertation examination committee and are awarded by the Ph.D. degree upon a successful defense.

The language of instruction and dissertations is English in the program. The department had 12 faculty members and four of them were working in the field of mathematics education at the time of the study.

### Participants

The study was announced to all mathematics education doctoral students in the program (i) who pursued their degrees after getting a M.S. degree; and (ii) who were in the integrated program and passed the doctoral comprehensive examination. Among the 20 contacted students, 10 (9 females and 1 male) accepted to participate. All of the participants had their Master's degrees and had taken research methodologies and statistics courses during the Master's studies. Three participants had not taken the advanced course on research methodologies. Two of the participants were writing their dissertations. One participant has passed the doctoral comprehensive examination and the others were in their first four semesters of the program. Seven participants were graduate assistants, five of which with contracts with other universities as future faculty members, one at another university, and one at the program department. One participant was working as an elementary mathematics teacher trainer in a private school and two were unemployed, one of which had previously worked in the department for six years.

Students may apply for doctoral programs in Turkey without an explicit research interest and/or a funded project. Their doctoral research is generally supported by the Graduate School of Social Sciences in terms of expenses once during their studies. They may participate in research other than their doctoral research not necessarily with financial benefits under the guidance of a faculty member. Students who are working as graduate assistants at public universities are paid a monthly salary on 12-month contracts and their primary duties are generally teaching related.

## Data Collection

Participants were asked to complete two tasks in the beginning of April 2012. The first task was an open-ended questionnaire with 19 major items asking doctoral students about their views of conducting research and of being a researcher in the field of mathematics education, future plans for research after completing their doctoral studies, and reflections on and evaluations of the mathematics education research in Turkey. The second task asked participants to develop a career plan considering their current research interest, future research plans, and anticipated problems at their future universities. Two tasks were initially piloted for language, clearness, and comprehensiveness with a mathematics education doctoral student at another department in the same faculty. Final versions of tasks were sent to participants via e-mail and they were given one week to respond and send their responses back in the same way.

Participants' responses were initially analyzed for conceptions of research and being a researcher in the field of mathematics education with focus on the role of the researcher, the research methodology, knowledge and skills needed for being a researcher, future plans, and future problems. Then, participants were invited to a one-day workshop developed through the findings of the initial analyses two weeks after they sent their responses. The responses were clustered around similar views and the aim of the workshop was to help participants to think about, discuss, clarify, and expand their views of conducting research and of being a researcher in the field of mathematics education. We also aimed to help them develop a more critical perspective on the conceptions and practices in the field. The participants discussed most of the questionnaire items in three groups in the first phase and were asked to write their group-agreed responses as well as different responses in the group. Then, all groups announced and discussed their responses facilitated by researchers. Extensive notes were taken through the workshop by the researchers. The aim of the second phase was to help participants develop more realistic career plans in the light of their discussions in the first phase.

## Data Analysis

Data of the study were participants' written responses to open-ended items in the questionnaire before the workshop, their group responses to some of the selected questions during the workshop, and notes taken by researchers during the workshop discussions. Data analysis process employed thematic analysis steps (Braun & Clarke, 2006), which were guided by research questions and data in a more flexible way. Data were first read by researchers several times, common

issues were detected among the responses, and an initial list of codes was generated. Coded data were clustered in potential themes. While conceptions of research and of being a researcher were themes driven by the research questions, conceptions related to the quality of the research was revealed as another theme during the analysis. The themes were reviewed through the codes and data, and finalized. Conceptions of research included purposes and outcomes of research and mathematics education research, audience of research, and research methods. Conceptions of quality of research included research process and capacity of research. Conceptions of being a researcher comprised researcher's knowledge and skills of researchers and their values and attitudes.

## Findings

### Conceptions of Research

In general, participants' conceptions of research in their written responses before the workshop mostly focused on the potential of closing a possible gap in the field, identifying possible problems objectively, and exploring people's ideas about the problem, as well as developing solution strategies for these problems. Contributing to the knowledge base and theories in the field and to the society were other reasons for conducting research. A doctoral student stated that:

Research is conducted for the purpose of serving science and society by providing new theories and products through investigation, and if necessary, evaluation of the existing research and theories.

The fundamental purpose of conducting mathematics education research was to improve the quality of mathematics instruction in schools by identifying and solving problems and removing gaps. Investigating factors affecting student achievement and teacher effectiveness in school mathematics was also one of the major purposes: “[Mathematics education research is conducted] in order to investigate the problems in the system [...], to provide ideas for what could be done for a better mathematics instruction, and to produce solutions.”

Participants elaborated more on the purposes of mathematics education research in the workshop. The nature of knowledge produced through the research was important while conducting mathematics education research. Doctoral students addressed that research should contribute to the mathematics education field through producing scientifically valid and reliable knowledge for the mathematics education. In this sense, evaluating existing programs and implementations in schools and research in the field was important. Specifically,

the validity of international research findings, education programs, and school based implementations in the Turkish context should be evaluated through the research. Understanding the nature of successful implementations was also considered as a focus of the research. One of the groups stated this in their written notes in the following way:

*[Mathematics education research] is conducted in order to determine the existing situation in the mathematics education. [...] Research is conducted both for successful and unsuccessful situations. If unsuccessful, [research is conducted] to figure out the problem. If successful, then [the reason for success are investigated].*

One of the groups also claimed that the research should raise the awareness about the undervalued issues in mathematics education and address research trends in the field. The contribution to society, teachers, students, and the theory in the mathematics education was also emphasized by all groups. The interesting issue in doctoral students' responses was that they did not specifically state the teacher education as an issue in the field of mathematics education although most research was conducted on teacher education issues in the department including some participants' Master's theses.

We were particularly concerned about how doctoral students conceptualized the audience of the mathematics education research. Questionnaire and workshop responses to the related item did not differ. Participants stated that research in mathematics education should have contribution to teachers' development and should inform people involved in this field, such as teacher educators and teachers themselves. They also mentioned that research should inform people who were responsible for quality of instruction in schools, such as curriculum developers and teachers. They argued that students were influenced by the research findings rather indirectly. Despite our request for a list of priority, most of our participants claimed that groups they mentioned had equal importance.

Doctoral students prioritized longitudinal, experimental, and qualitative methodologies in the field of mathematics education in their written responses. In the workshop, they additionally mentioned that review studies, action research, and mixed methodologies should be employed in mathematics education research. The emphasis on the longitudinal and in-depth studies was also apparent in their workshop responses such as "Longitudinal studies should be conducted especially when there is a new implementation in the education system in order to study them in the long-term" and "... Because previously identified problems and deficiencies may better be solved by these methodologies."

## Quality of a Research

Doctoral students' written responses about the quality of research in the field of mathematics education addressed that the research should be planned and carried out thoroughly. The research process should produce valid, reliable, and significant knowledge, as well as applicable and realistic results for the field. Research should be methodologically sound and have a strong theoretical background. The context and researcher's stance were important and should be acknowledged:

*The research process should be well-structured. The topic should be worthy, the proper sample should be identified, the supports that could be received should be planned, [and] data collection tools should be determined previously. [The research topic] should be addressed as important in the literature, should have a theoretical background, should be free from bias, should be realistic, and should have a possible aim of finding a solution to a problem.*

Analysis of the workshop discussions revealed that the capacity of research to direct further research was important for participants. They argued that the communication of findings should be clearly expressed so that stakeholders could make sense. Discussions addressed teachers as the group for which the findings of the research were less communicated and participants criticised researchers for not making their findings accessible to teachers.

*We ignore the relative importance of the publication for the reader. The findings are presented only for the researchers, teachers may not have any information about [the findings].*

*Participants also argued that the quality of the research was evident in its potential to inform the contexts beyond the research context and its capacity to be published in highly respected journals.*

## The Mathematics Education Researcher

Doctoral students' conceptions of a mathematics education researcher were sought both in the questionnaire and in the workshop by means of the knowledge, skills, attitudes, and values that researchers should have. Written responses revealed that the mathematics education researcher should have up to date knowledge in the field, in the related literature, and in research methodologies. Having critical knowledge of the field was prioritized by some of the doctoral students: "First of all, [the researcher] should be competent in his/her field, have an idea about

the related studies, and be able to interpret and discuss them. He/she should be sensitive about how research is conducted.”

Participants pointed that being a reflective thinker and being objective in interpreting his/her own research were important characteristics of researchers. In addition they argued that a researcher should be creative and foresighted:

*... the basic skills that researchers should have are being able to inquiry and reflect. Mathematics education researcher should follow the new improvements and investigate their results. Meanwhile, he/she should evaluate these in order to improve his/her knowledge and skills. He/she should also reflect these in his/her communities and relationships.*

*[The mathematics education researcher] should be creative, be able to observe problem situations or see the new problem situations within the existing research, should be able to investigate these [problems] through scientific methods, should use the mathematical language well, and should have the skill for verbal and written [communication].*

Some of the participants gave a more detailed account of what they meant by the knowledge of the field. They argued that the knowledge of field in mathematics education would include mathematics content knowledge, pedagogical content knowledge, knowledge of pedagogy, and knowledge of theories and research in the field. Participants stated that a researcher should have skills to implement this knowledge into their research and be a problem solver.

In their written responses, participants’ conceptions of attitudes and values of a mathematics education researcher emphasized being open to improvement and the person’s willingness to contribute to the field. According to participants, a researcher should also be sensitive to ethical issues and have a concern for the society, as well as for his/her participants:

*He/she should be open to new improvements and should aim to contribute to mathematics teaching and learning by communicating other people in the mathematics education field.*

*He/she should not consider the teachers, students, preservice teachers, and researchers as a “sample”, but see them as “human beings” and be aware of the fact that his/her research is affecting these people in some ways and [research] is not mechanical. In short, he/she should value people... should have ethical principles in research.*

*He/she should not misinterpret the findings of his/her research. The findings may contradict with certain groups [and individual's] personal or financial gains. In this case, he/she should express the findings as they are. He/she should have the value that expressing the true findings contributes to the science and society instead of considering individual's gains and power.*

Participants addressed personality traits of a researcher such as being “disciplined and organized”, “patient”, “enterprising”, “collaborative”, “responsible”, and “respectful” in their written responses. The mathematics education researcher should have developed effective research skills such as observation and written and oral communication as well as discussion and listening.

The most discussed issue in the workshop was patience and collaboration among mathematics education researchers. Doctoral students addressed that researchers tend to conduct rather short-term studies because long-term studies would require more patience and time taking procedures to be conducted. They stated that the lack of effective collaborative skills were a result of considering personal ambition and gains more than the benefit for the society.

## Conclusion

The purpose of the current study was to investigate mathematics education doctoral students' conceptions of research and of being a researcher. One of our intentions was to explore their beliefs, meanings, mental images, and ideas as contextualized in the field of mathematics education, through questions about their research intentions, outcomes, questions, processes, as well as their feelings about research, which were addressed as dimensions of such conceptions (Akerlind, 2008). An initial motivation for the research for doctoral students was a problem or a gap. Attempting to solve problems of mathematics education and addressing gaps through the research should be the major aim in conducting research, outcome of which would contribute to the theory in the mathematics education field. Research, in this sense, should target improving the quality of mathematics instruction at schools. Reported conceptions seemed to align with conceptions addressing finding solutions to problems and gathering information for the benefit of the society reported for researchers in other fields. The researcher was the agent who provided this benefit for the society through a thorough, ethical, and responsible research process. These conceptions seemed to be partly the outcome of individual doctoral students' common experiences within the specific doctoral program.

The findings indicated that doctoral students' conceptions reflected national and local (program) culture of mathematics education research. The strong emphasis on identifying and solving problems in participants' conceptions reflected the nature of the education research discourse in Turkey addressing mostly the problematic aspects. Although we aimed to help them initiate a critical perspective during the workshop through discussions and our questions, there were only few responses which were more critical of the research practices in Turkey and in the program. At a more local level, the emphasis on the lack of communication of research findings to parties other than researchers was an example a more critical perspective and reflecting a self-criticism of the program. Their textbook-like expressions for quality of research reflected the dissertation and thesis writing traditions in the program in which strict sections describing the research methodology and certain expressions were required.

Interestingly, participants did not specifically address that students could benefit from the research directly. Most of our participants' research interests were related to either teacher education or teachers. This could be the reason for considering students as influenced by research rather indirectly.

Our findings revealed that doctoral students seemed to prioritize social benefit of research more than individual benefit. We did not have any data suggesting that our participants addressed personal gains such as reputation or fulfilling requirements as the outcome of research as reported by previous research (Akerlind, 2008; Stubb, Pyhäntö, & Lonka, 2012). This may be due to the rather collectivist broader social culture the doctoral students participate. On the other hand, it should be noted that the researchers were faculty members in the program and participants were doctoral students taking classes or working in the same program together. Although we tried to encourage participants to reveal their true thoughts and intentions, it could be the case that they did not choose to share certain personal goals in such a community.

Doctoral programs are places where research traditions in mathematics education are produced and reproduced. Conceptions of research and researcher among doctoral students may influence future research trends in mathematics education and in training mathematics education researchers. Further research should explore how these conceptions are formed and how they influence further research decisions of novice researchers.



## References

- Akerlind, G. S. (2008). An academic perspective on research and being a researcher: An integration of the literature. *Studies in Higher Education*, 33(1), 17–31.
- Baki, A., Güven, B., Karataş, İ., Akkan, Y., & Çakıroğlu, Ü. (2011). Trends in Turkish mathematics education research: From 1997 to 2007. *Hacettepe University Journal of Education*, 40, 57-68.
- Braun, V., & Clarke, V. (2006). Using thematic analysis psychology. *Qualitative Research in Psychology*, 3, 77-101.
- Brew, A. (2001). Conceptions of research: A phenomenographic study. *Studies in Higher Education*, 26(3), 271-285.
- Stubb, J., Pyhältö, K., & Lonka, K. (2012). Conceptions of research: The doctoral student experience in three domains. *Studies in Higher Education*, DOI:10.1080/03075079.2011.651449.
- Meyer, J. H. F. (2007). On the modelling of postgraduate students' conceptions of research. *South African Journal of Higher Education*, 21(8), 1103-1116.
- Meyer, J. H. F., Shanahan, M. P., & Laugksch, R. C. (2005). Students' conceptions of research I: A qualitative and quantitative analysis. *Scandinavian Journal of Educational Research*, 49(3), 225–244.
- Philipp, R. A. (2007). Mathematics teachers' beliefs and affect. In F. K. Lester, Jr., (Ed.), *Second Handbook of Research on Mathematics Teaching and Learning: A Project of the National Council of Teacher of Mathematics* (pp. 257-318). Charlotte, NC: Information Age Publishing.
- Pitcher, R. (2011). *Doctoral students' conceptions of research. The Qualitative Report*, 16(4), 971-983.
- Richardson, V. (1996). The role of attitudes and beliefs in learning to teach. In J. Sikula (Ed.), *Handbook of Research on Teacher Education (2<sup>nd</sup> ed.)* (pp. 102–119). New York, NY: Macmillan.
- Sriraman, B. (2010). Mathematics education in Turkey: At the crossroads of cultural, political, and economic currents. *ZDM Mathematics Education*, 42, 421-427.
- Ubuz, B., Çakıroğlu, E., & Erbaş, A.K. (2011). A survey of mathematics education doctoral programs in Turkey. In B. Ubuz (Ed.), *Proceedings of the 35<sup>th</sup> Conference of International Group for the Psychology of Mathematics Education* (Vol. 1, pp. 187-201). Ankara, Turkey: PME.
- Wood, K. (2006). Changing as a person: the experience of learning to research in the social sciences. *Higher Education Research & Development*, 25(1), 53–66.

## Feeling of innovation in expert problem posing

IGOR KONTOROVICH AND BORIS KOICHU

ik@tx.technion.ac.il

Technion – Israel Institute of Technology

### Abstract

*This paper is one of the reports on a multiple-case study concerned with the intertwining between affect and cognition in the mechanisms governing experts when posing new mathematical problems. Based on inductive analysis of a single case of an expert poser for mathematics competitions, we suggest that the desire to experience the feeling of innovation may be one of such mechanisms. In the case of interest, the feeling was realized through the expert's reflections on the problems he created in the past, by systematically emphasizing how a new problem was innovative in comparison with other familiar problems based on the same nesting idea. The findings are discussed in light of past research on expert problem posers and expert problem solvers.*

### Keywords

*experts, mathematical competitions, nesting ideas, problem posing.*

### Introduction

Mathematics education research has accumulated an extended body of knowledge on problem posing by school children and mathematics teachers who, as a rule, are novices in problem posing (Kontorovich, Koichu, Leikin & Berman, 2012). On the other hand, empirical evidence on problem posing by experts, i.e. mathematicians and mathematics educators, who create new problems for various mathematical and educational needs as an integrative part of their professional practice, barely exists. This is in spite of the established practice of using research on experts as a source of ideas for fostering mathematical competences in novices. For instance, the mathematics education community has benefited from studies on how experts in mathematics *solve* problems (e.g., Carlson & Bloom, 2005), *learn* mathematics (e.g., Wilkerson-Jerde & Wilensky, 2011) and *discover* new mathematical facts (e.g., Liljedahl, 2009). By analogy, research on how experts *pose* problems may also be profitable and lead to new ideas about how to improve problem-posing competences in school children and mathematics teachers.

In the framework of a larger research (Kontorovich, in prep.) we study a community of expert problem posers for mathematics competitions for secondary school children. This community is particularly interesting because mathematics competitions are widely recognized as a valuable source of elegant and surprising problems for the use not only in out-of-school educational settings, but also in a regular mathematics classroom. Many competition problems have served as powerful means of engaging school children in challenging mathematics, fostering their mathematical thinking and creativity (e.g., Koichu & Andžāns, 2009; Thraser, 2008). In addition, it is just intriguing to understand how the experts succeed to come up with new and surprising problems after that so many mathematical gems have been created for competitions during the last century.

We decided to look at expert problem posers' ways of thinking and practice through the lenses that intertwine cognitive and affective domains. The decision is set in-line with the recent stream of research in different fields of mathematics education. Generally speaking, the research agenda that stimulated us is that each domain has its own limitations, but considering both of them together may help in exposing a "bigger picture" (see Furinghetti & Morselli, 2009 for an elaborated substantiation of this claim).

In the current paper we present data from a case study with one expert poser, Leo (pseudonym). The case of Leo was chosen because it was particularly informative with respect to mathematical, cognitive and affective aspects of creating problems. The goal of the case study was to formulate evidence-based suggestions on how affect may be involved when the expert operates upon his knowledge base when posing new mathematical problems.

## Theoretical Background

### Experts' problem posing and affect

Publications, in which expert problem posers open the doors of their kitchens, are rare. We found only three self-reflective publications of this kind: by Konstantinov (1997), Sharigin (1991) and Walter (1987). Overall, the papers inform the readers about sources of new problems, problem-posing techniques and the authors' quality criteria for the posed problems. On one hand, Walter (1978) illustrates a claim that a problem can be created "almost from anything", i.e. almost from any situation including drawings or numerical information. On the other hand, Sharigin (1991) points out that new (competition) problems usually come from other problems the poser is familiar with.

The aforementioned self-reflective writings create an impression that problem posing is a very affectively loaded experience for the experts. This impression gets even stronger when we look at the ways Sharigin (1991) and Konstantinov (1997) describe good competition problems, which can be considered as high-quality products of problem posing. They use such descriptors as “graceful”, “attractive”, “surprising”, “sophisticated”, “natural”, “beautiful”, “impressive”, “rich”, “mathematically valuable”, “interesting” and “original” (translated from Russian). However, the self-reflective writings of the masters do not fully enable the readers to understand the meaning beyond the descriptors. In Konstantinov’s (1997) words: “It is impossible to formulate what is a “good problem”. But when the problem is posed it claims for itself (or against itself)” (p. 168, translated from Russian). Indeed, Konstantinov’s (1997) view is emotionally loaded and high-quality product oriented. In turn, it leaves room for inquiring how affect is involved in the processes the experts are going through when posing high-quality problems.

#### Experts’ problem posing and organization of their knowledge base

Expert mathematical knowledge base is more than just storage of pieces of information, like definitions, facts and routine procedures. It also includes the ways this information is represented, stored, organized and accessed (e.g., Schoenfeld, 1992). Another important part of mathematical knowledge base for problem solving, and, apparently, for problem posing, is a set of rules and norms that exist in the particular domain about legitimate and prototypical connections between different pieces of mathematical information (Schoenfeld, 1992). This kind of knowledge is constructed through continuous exposure to various mathematical problems, elaboration on a part of them and storage of problems in the knowledge base; in this way, a *personal pool of familiar problems* is being constructed.

A personal pool of familiar problems of an expert problem poser is immense. According to Miller (1956), when experts operate with a big amount of information, their first thing to do is to break it down into meaningful *chunks*, which make the information more accessible. Then experts imply their extended arsenal of *schemas* to the chunked information. *Schemas* are referred to as organized structures of mental actions for associating new information with already existing one (e.g., Schoenfeld, 1992). They are used for making a personal sense of information, coding and storing it in the long-term memory as well as for recalling and decoding it back (e.g., Chi, Feltovich & Glaser, 1981).

How can *chunking* and *schemes* be used to characterize an expert's pool of familiar problems for mathematical problem solving and problem posing? Namely, what kinds of familiar problems are grouped in the same chunk? Empirical studies on problem solving showed that experts group problems together in a good agreement with a *deep vs. surface structure* theory (e.g., Chi, Feltovich & Glaser, 1981). Generally speaking, research tells us that experts tend to identify problems as being similar because of the fundamental principles and strategies that lead to their solutions (deep structure), and not according to their surface structure, such as similar scientific fields or topics, usage of the same mathematical terms etc.

Let us note that in the study mentioned in the previous paragraph, the participants were experts in problem solving. In this case, associating an unfamiliar problem with familiar ones using the schema of "looking for deep-structure similarities between the problems" has been summoned. In our case, Leo's expertise is in posing challenging problems for the solution by others (i.e. students attending mathematics competitions). Therefore, the question of which schemas he is using and how he takes advantage of his immense pool of familiar problems is worth asking.

## The case of Leo

Leo is a coach of the Israeli team for International Mathematical Olympiad (IMO) for high school students and a practicing problem poser. His problems have appeared in high-level competitions such as the Tournament of the Towns, IMO for university students and national-level Olympiads in Israel. The data on Leo's problem posing was collected in the framework of two interviews, a master class for a group of prospective mathematics teachers, a meeting, in which Leo and his colleagues constructed a questionnaire for one of the preparatory stages for the Israeli national-level Olympiad and a meeting during which Leo gave feedback on our analysis of his problem-posing practices. All the meetings with Leo were video- or audiotaped, so, overall, the case of Leo is based on more than 10 hours of recorded data.

We present below several fragments of data gathered in the framework of the reflective interview (more data are presented in Kontorovich & Koichu, in press, 2012). The interview was organized as a conversation around selected problems created by Leo in the past and took about 125 minutes. The problems to be discussed at the interview were sent to us by Leo in advance, which enabled us to prepare well-focused questions about each problem.

The data were analyzed using an inductive approach in order “[...] to allow research findings to emerge from the frequent, dominant or significant themes inherent in raw data, without the restraints imposed by structured methodologies” (Thomas, 2006, p. 238). To make the inductive analysis more transparent we chose to present the findings based on the way in which the categories emerged from the data.

## Findings

Prior to the interview, Leo sent us a list of seventeen of his problems. The problems belonged to the fields of Euclidean, analytical and spatial geometries, algebra, graph theory, logic and combinatorics. Two problems, which have appeared in Israeli national-level competition for 8<sup>th</sup> and 9<sup>th</sup> graders, drew our particular attention because of their apparent similarity: they shared the same question and could be solved by using the idea of (algebraic) conjugate numbers.

Problem 1: Simplify  $\frac{\sqrt{\sqrt{2}-1}}{\sqrt{\sqrt{2}+1}} + \frac{\sqrt{\sqrt{3}-\sqrt{2}}}{\sqrt{\sqrt{3}+\sqrt{2}}} + \frac{\sqrt{2-\sqrt{3}}}{\sqrt{2+\sqrt{3}}}$ .

Problem 2: Simplify

$$\frac{1}{\sqrt[3]{4} + \sqrt[3]{6} + \sqrt[3]{9}} + \frac{1}{\sqrt[3]{9} + \sqrt[3]{12} + \sqrt[3]{16}} + \frac{1}{\sqrt[3]{16} + \sqrt[3]{20} + \sqrt[3]{25}}$$

When Leo was asked to reflect on these problems, he chose to reflect on the second one. He said:

*I needed an algebraic problem for a competition. What can be done in algebra so it would be elementary, but still unexpected? I like [algebraic] conjugate numbers since they are unexpected enough. [...] Especially when one number is a predecessor of the other, since then the numerator of 1 is masked [i.e.*

$$\sqrt{n+1} - \sqrt{n} = \frac{1}{\sqrt{n+1} + \sqrt{n}}]. \text{ [...] OK, [I wanted to use] conjugate}$$

*numbers! But quadratic conjugate numbers is hackneyed, boring and everybody knows them. So let's take a step forward: cubic conjugate numbers. This thought gave birth to the second problem.*

Three phenomena could be observed in Leo's reflection. First, when creating Problem 2 Leo *desired to innovate*, i.e. he was incentive to pose a problem which would be different from the ones existing in his pool. A desire to innovate is acknowledged as being common, natural and primary motivating factor among humans (e.g., Doboli et al., 2010; Knight, 1967).

Second, in order to innovate Leo turned to the idea of "conjugate numbers". It seems like Leo used the idea of "conjugate numbers" as a code name referring to a whole class of problems. The class contains problems that involve expressions with roots, which can be simplified using the properties of algebraic conjugate numbers. The existence of Problem 1 implied that Leo had already successfully turned to this class of problems. Thus, it is reasonable to assume that this prior positive experience awarded special status to the idea of "conjugate numbers" for Leo. Then Leo scanned the whole class, noticed that it embraces problems which only involve quadratic roots and introduced cubic conjugate numbers in Problem 2. Overall, it can be said that Leo *manipulated* the special idea for making an innovation.

The exposed characteristics of an idea of "conjugate numbers" stimulated us to resort to a metaphor of a nest that encloses familiar problems (i.e. "egges") and serves as a useful framework for "laying" new ones. Thus, we refer to this kind of ideas as *nesting ideas*. Note that, as any metaphor, this one has its limitations. For instance, although it cannot be seen from the presented data, Leo's nests of ideas embrace problems created by Leo as well as problems created by others.

Third, Leo has stopped his problem posing after introducing cubic conjugate numbers. Thus it can be suggested that the manipulation ended up with a problem which was innovative enough in his eyes. Moreover, Leo remembered so well the story of creation of Problem 2, which had appeared at the competition two years ago. In this way, the creation of Problem 2 can be recognized as a significant experience for him, which left traces in Leo's memory for a long time after it actually occurred. This kind of experiences is accompanied by a highly-emotional impact and, in particular, by strong feelings (e.g., Hochschild, 1983).

From the literature on innovations we know that the fulfillment of the desire to innovate creates a pleasant feeling related to the positive self-perceptual "package" including pride, success, self-efficacy, development, improvement and significance (e.g., Doboli et al., 2010; Knight, 1967). In the problem-posing context we refer to this feeling as a *feeling of innovation*; a feeling which appears after a poser created a problem which is different enough from the problems / he is familiar with.

Table 1. Additional examples of problems created by Leo.

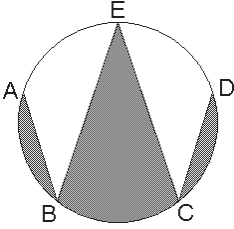
<i>Problem</i>	<i>Class the problem belongs to</i>
<p>Problem 3: At what time the clock hands are perpendicular?</p> <p>(Appeared at Israeli national-level competition for secondary students in 2010).</p>	<p>Clock problems:</p> <p>The class consists of problems about analogical clocks and special positions of their hands. Probably the most known problem of the class is: “When do the hour and minute hands coincide after 12 o'clock?”</p> <p>The Leo’s innovation in Problem 3 was a question about perpendicular position of the clock’s hands.</p>
<p>Problem 4: The points <math>A, B, C, D, E</math> are located on the circle so that the distance between two neighbouring points is constant.</p>  <p>The broken line <math>ABCDE</math> divides the area of the circle into two areas: below the line (the grey area) and above the line (the white area). Which area is bigger: the grey or the white one?</p> <p>(Appeared at Israeli national-level competition for 8<sup>th</sup> and 9<sup>th</sup> graders in 2007).</p>	<p>Cutting problems:</p> <p>The problems of this class are based on a figure divided into two areas by a curve. The typical question of the class is “Which area is larger and why?” and the typical answer is that the areas are equal, whereas they do not look equal. Leo likes this class of problems because they are based on quite basic knowledge of Euclidian geometry and do not require knowledge of rarefied facts.</p> <p>The Leo’s innovation in Problem 4 was that the grey area is larger than the white one, although it is not obvious at the picture.</p>



Problem 5: Two ellipses share a focus. Prove that the ellipses intersect in two points at the most.

(Appeared in IMO for college students in 2008).

Ellipse:

The problems with ellipse belong to this class. Leo told us that ellipses are one of his favourite topics in plain geometry and that he frequently uses them in his problem posing. This is because ellipses have many interesting properties, and not many people know them. Therefore, the innovation is realized through creating problems using a rarefied property of an ellipse.

Indeed, Problem 5 can be solved using an uncommon definition of ellipse involving a point and a directrix.

---

Leo's reflection on the creation of Problem 2 led us to two interrelated hypotheses: (1) the entire pool of Leo's familiar problems may be organized in classes of problems structured by nesting ideas; (2) the feeling of innovation is likely to appear as the result of manipulating or modifying nesting ideas. Having these conjectures in mind, we explored the data set and identified more than forty nesting ideas in Leo's arsenal belonging to various mathematical branches and topics. Leo also told us about more than twenty problems that he created by manipulating or modifying nesting ideas from his arsenal. Three additional examples of problems created by Leo are presented in the left column in Table 1. The problems' formulations are presented in the left column in Table 1; the right column includes the code names of the classes used by Leo, the description of commonalities between the problems belonging to the class and the essence of Leo's innovation inherent in the posed problem.

## Summary and discussion

In the paper we presented fragments of data from a case study of an expert who professionally poses problems for mathematics competitions. Our goal was to substantiate a claim that when creating problems, the expert desires to get a *feeling of innovation*, when his pool of familiar problems serves as a baseline. We illustrated that the feeling may be achieved at the result of manipulating with *nesting ideas* – special organizational units which are ubiquitous in different mathematical topics and fields in expert's pool of familiar problems. In this

way, the paper provides an evidence-based example of a symbiotic relationship between cognitive and affective domains. Namely, we illustrated how a cognitive structure (i.e. nesting idea) is intertwining with the achievement of a desire of affective nature (i.e. the feeling of innovation). Taken together, these two may partially explain how high-quality mathematical products (i.e. problems for high-level mathematics competition) appear in the expert's practice. In the following subsections we discuss the introduced notion of nesting ideas in light of the well-known cognitive structures from past research and point out possible explanation for expert's motivation to achieve the feeling of innovation.

### Nesting ideas vs. chunking and schemas

The notion of nesting idea bears a resemblance to a notion of chunk, since they both are operational ways of dealing with a large amount of data (see Theoretical Background section). Thus, nesting ideas can be considered as special chunks of expert's pool of familiar problems. Leo's practice of manipulation with or modification of various nesting ideas can be considered as a problem-posing scheme: a structured mental action with familiar piece of knowledge aiming at the creation of a new one (see Theoretical Background section again).

The notion of nesting ideas can turn to be instrumental for pointing out the differences between expertise in problem solving and problem posing. In the context of problem solving experts tend to focus on the similarities in the problems' deep structures.. The fragments of presented data exemplify two additional types of nesting ideas, i.e. two additional types of reasons for Leo to include familiar and newly constructed problems in the same class: surface structure nesting ideas (see "cutting problems") and nesting ideas based on particularly rich situations (see "ellipses"). The former type reflects *deep* vs. *surface structure* theory mentioned in Theoretical Background and the later refers to situations with a considerable number of mathematical properties, when each property is represented by a problem in the class. In this type of nesting ideas the deep-level connection between problems' solutions are possible but non-obligatory. In this way, considering alternatives to nesting ideas of a deep structure can be useful at least in some cases in the context of problem posing.

### Expert's motivation to achieve the feeling of innovation

We suggest that expert's desire to achieve the feeling of innovation steams from three sources. *The first source* is pedagogical: From the perception analysis of 22 adult participants of the competition movement, presented at the previous MAVI conference (Kontorovich, 2012), we have concluded that competition

problems are aimed at achieving four (interrelated) pedagogical goals: to supply opportunities for learning meaningful mathematics, to strengthen a positive attitude towards a particular problem and mathematics in general, to create a cognitive difficulty and to surprise. These goals cannot be achieved without a permanent innovation of the pool of competition problems.

*The second source* is intellectual: Fulfilling a desire to innovate can end up with a creation of a new problem which integrates in the pool of familiar problems and enriches it. Creating such problems can be seen as an act of acquiring significant knowledge by the expert. This perspective is in line with Ericsson's (2006) one, who wrote that experts tend to engage themselves in deliberate practices in order to extend their already well-developed knowledge base and to sharpen their professional skills. In the problem-posing context the journey from the desire to innovate to the feeling of innovation may be accompanied by positive "research" feelings such as excitement of scientific exploration, the thrill of discovery and the sense of ownership for the result (e.g., Liljedahl, 2009).

*The third source* is social: Mathematics competition movement is a special case of a professional community of practice. One of the characteristics of such communities is an aspiration to gain knowledge. Thus the participants of the community appreciate collaboration, innovation and enrichment of an existing community knowledge base. Their appreciation can fulfil expert's social needs in belonging, esteem and respect (Maslow, 1943).

## References

- Carlson, M., & Bloom, I. (2005). The cyclic nature of problem solving: An emergent multidimensional problem-solving framework. *Educational Studies in Mathematics*, 58, 45-75.
- Chi, M. T. H., Feltovich, P. J., & Glaser, R. (1981). Categorization and representation of physics problems by experts and novices. *Cognitive Science*, 5, 121-152.
- Doboli, S., Tang, W., Ramnath, R., Impagliazzo, J., VanEpps, T., Agarwal, A., Romero, R., & Currie, E. H. (2010). Panel – Models of entrepreneurship education and its role in increasing creativity, innovation and leadership in computer science and engineering students. In *Proceedings of the 40th ASEE/IEEE Frontiers in Education Conference*, Washington DC.
- Ericsson, K. A. (2006). The influence of experience and deliberate practice on the development of superior expert performance. In K. A. Ericsson, N. Charness, P. Feltovich, & R. R. Hoffman (Eds.), *Cambridge Handbook of Expertise and Expert performance* (pp. 685-706). Cambridge, UK: Cambridge University Press.

- Furinghetti, F., & Morselli, F. (2009). Every unsuccessful problem solver is unsuccessful in his or her own way: affective and cognitive factors in proving. *Educational Studies in Mathematics*, 70, 71-90.
- Hochschild, A. R. (1983). *The managed heart: Commercialization of human feeling*. Berkeley: University of California Press.
- Knight, K. E. (1967). A descriptive model of the intra-firm innovation process. *The Journal of Business*, 40(4), 478-496.
- Koichu, B., & Andžāns, A. (2009). Mathematical creativity and giftedness in out-of-school activities. In R. Leikin, A. Berman, & B. Koichu (Eds.), *Creativity in Mathematics and Education of Gifted Students* (pp. 285-308). Rotterdam, The Netherlands: Sense Publishers.
- Konstantinov, N. N. (1997). Tournir Gorodov i matematicheskaya olimpiada [Tournament of the Towns and mathematical Olympiad]. *Matematicheskoe Prosvetshenie*, 3(1), 164-174. (in Russian).
- Kontorovich, I. (2012). What makes an interesting mathematical problem? A perception analysis of 22 adult participants of the competition movement. In B. Roesken & M. Casper (Eds.), *Proceedings of the 17th MAVI (Mathematical Views) Conference* (pp. 129-139). Bochum: Germany.
- Kontorovich, I. & Koichu, B. (in press). A case study of an expert problem poser for mathematics competition. *International Journal of Science and Mathematics Education*.
- Kontorovich, I. & Koichu, B. (2012). Feeling of innovation in expert problem posing. *Nordic Studies in Mathematics Education*, 17(3-4), 199-212.
- Kontorovich, I., Koichu, B., Leikin, R., & Berman, A. (2012). An exploratory framework for handling the complexity of mathematical problem posing in small groups. *Journal of Mathematical Behaviour*, 31(1), 149-161.
- Liljedahl, P. (2009). In the words of the creators. In R. Leikin, A. Berman, & B. Koichu (Eds.), *Creativity in Mathematics and Education of Gifted Students* (pp. 51-70). Rotterdam, The Netherlands: Sense Publishers.
- Maslow, A. (1943). A theory of human needs. *Psychological Review*, 50, 370-396.
- Miller, G. A. (1956). The magical number seven, plus or minus two: Some limits on our capacity for processing information. *The Psychological Review*, 63, 81-97.
- Pelczer, I., & Gamboa, F. (2009). Problem Posing: Comparison between experts and novices. In M. Tzekaki, M. Kaldrimidou, & C. Sakonidis (Eds.), *Proceedings of the 33th Conference of the International Group for the Psychology of Mathematics Education* (vol. 4, pp. 353-360). Thessaloniki, Greece: PME.
- Schoenfeld, A. (1992). Learning to think mathematically: problem solving, metacognition, and sense making in mathematics. In D. A. Grows (Ed.),

- Handbook of research on mathematics teaching and learning* (pp. 334-370). New York: Macmillan.
- Sharigin, I. F. (1991). Otkuda berutsia zadachi? [Where do problems come from?] Part I, *Kvant*, 8, 42-48; part II, *Kvant*, 9, 42-49. (in Russian).
- Silver, E.A., Mamona-Downs, J., Leung, S., & Kenney, P. A. (1996). Posing mathematical problems: an exploratory study. *Journal for Research in Mathematics Education*, 27(3), 293-309.
- Thomas, D. T. (2006). A general inductive approach for analyzing qualitative evaluation data. *American Journal of Evaluation*, 27(2), 237-246.
- Thrasher, T. N. (2008). The benefits of mathematics competitions. *Alabama Journal of Mathematics*, Spring-Fall, 59-63.
- Walter, M. (1978). Generating problems almost from anything, part I. *Mathematics Teaching*, 120, 3-7; part II, *Mathematics Teaching*, 121, 2-6.
- Wilkerson-Jerde, M. H., & Wilensky, U. J. (2011). How do mathematicians learn math?: resources and acts for constructing and understanding mathematics. *Educational Studies in Mathematics*, 78, 21-43.

## **Illumination: Cognitive or affective?**

PETER LILJEDAHL

liljedahl@sfu.ca  
Simon Fraser University

### **Abstract**

*What is the nature of illumination in mathematics? That is, what is it that sets illumination apart from other mathematical experiences? In this article the answer to this question is pursued through a qualitative study on the mathematical experiences of prominent research mathematicians. Using a methodology of analytic induction in conjunction with historical and contemporary theories of discovery, creativity, and invention along with theories of affect the anecdotal reflections of participants are analysed. Results indicate that what sets illumination apart from other mathematical experiences are the affective aspects of the experience.*

### **Keywords**

*AHA!, creativity, illumination, mathematics*

### **Introduction**

*Perhaps I could best describe my experience of doing mathematics in terms of entering a dark mansion. One goes into the first room, and it's dark, completely dark. One stumbles around bumping into the furniture, and gradually, you learn where each piece of furniture is, and finally, after six months or so, you find the light switch. You turn it on, and suddenly, it's all illuminated. (Andrew Wiles, from Nova (1993))*

Suddenly, it's all illuminated. In the time it takes to turn on a light the answer appears and all that came before it makes sense. A problem has just been solved, or a new piece of mathematics has been found, and it has happened in a flash of insight – in a flash of illumination. Literature is rich with examples of these instances of illumination – from Amadeus Mozart's seemingly effortless compositions (Hadamard, 1945) to Samuel Taylor Coleridge's dream of Kubla Kahn (Ghiselin, 1952), from Leonardo da Vinci's ideas on flight (Perkins, 2000) to Albert Einstein's vision of riding a beam of light (Ghiselin, 1952) – all of which exemplify the role of this elusive mental process in the advancement of human

endeavours. In science, as in mathematics, significant advancement is often associated with these flashes of insight, bringing forth new understandings and new theories in the blink of an eye. But what is the nature of this phenomenon?

Simply put, illumination is the phenomenon of “sudden clarification” (Pólya, 1965, p. 54) arriving in a “flash of insight” (Davis & Hersh, 1980, p. 283) and accompanied by feelings of certainty (Burton, 1999; Fischbein, 1987). In sum, it is the experience of having an idea come to mind with “characteristics of brevity, suddenness, and immediate certainty” (Poincaré, 1952, p.54). However, illumination is more than just this moment of insight. It is this moment of insight on the heels of lengthy, and seemingly fruitless, intentional effort (Hadamard, 1945). It is the turning on the light after six months of groping in the dark.

In this article I explore this phenomenon more closely through the anecdotal reflections of research mathematicians. In particular, I look at what it is that sets the phenomenon of illumination apart from more ordinary mathematical experiences. But first, I offer an historical account of the emergence of the idea of illumination into the field of mathematics.

## History

In 1902, the first half of what eventually came to be a 30 question survey was published in the pages of *L'Enseignement Mathématique*, the journal of the French Mathematical Society. Édouard Claparède and Théodore Flournoy, two Swiss psychologists, who were deeply interested in the topics of mathematical discovery, creativity and invention, authored the survey. Their hope was that a widespread appeal to mathematicians at large would incite enough responses for them to begin to formulate some theories about this topic. The responses were sorted according to nationality and published in 1908.

During this same period Henri Poincaré (1854–1912), one of the most noteworthy mathematicians of the time, had already laid much of the groundwork for his own pursuit of this same topic and in 1908 gave a presentation to the French Psychological Society in Paris entitled *L'Invention mathématique*—often mistranslated to *Mathematical Creativity* (c.f. Poincaré 1952). This presentation, as well as the essay it spawned, stands to this day as one of the most insightful and reflective instances of illumination as well as one of the most thorough treatments of the topic of mathematical discovery, creativity, and invention.

*Just at this time, I left Caen, where I was living, to go on a geological excursion under the auspices of the School of Mines. The incident of the travel made*

*me forget my mathematical work. Having reached Coutances, we entered an omnibus to go some place or other. At the moment when I put my foot on the step, the idea came to me, without anything in my former thoughts seeming to have paved the way for it, that the transformations I had used to define the Fuschian functions were identical with those of non-Euclidean geometry. I did not verify the idea; I should not have had the time, as, upon taking my seat in the omnibus, I went on with the conversation already commenced, but I felt a perfect certainty. On my return to Caen, for conscience' sake, I verified the results at my leisure. (Poincaré 1952)*

So powerful was his presentation, and so deep were his insights that it could be said that Poincaré not so much described the characteristics of mathematical creativity, as defined them. From that point forth mathematical creativity, or even creativity in general, has not been discussed seriously without mention of Poincaré's name.

Inspired by this presentation, Jacques Hadamard (1865-1963), a contemporary and a friend of Poincaré's, began his own empirical investigation into this fascinating phenomenon. Hadamard had been critical of Claparède and Flournoy's work in that they had not surveyed "first-rate men" (p. 10), men who would dare to speak of both successes and failures in the context of invention. So, Hadamard retooled the survey and gave it to friends of his for consideration—mathematicians such as Henri Poincaré and Albert Einstein, whose prominence were beyond reproach. In 1943 Hadamard gave a series of lectures on mathematical invention at the École Libre des Hautes Études in New York City. These talks were subsequently published as *The Psychology of Invention in the Mathematical Field* (Hadamard, 1945).

Hadamard's treatment of the subject of invention at the crossroads of mathematics and psychology is an extensive exploration and extended argument for the existence of unconscious mental processes. To summarize, Hadamard took the ideas that Poincaré had posed and, borrowing a conceptual framework for the characterization of the creative process from the Gestaltists of the time (Wallas, 1926), turned them into a stage theory. This theory still stands as the most viable and reasonable description of the process of mathematical invention.

The phenomenon of mathematical invention consists of four separate stages stretched out over time. These stages are initiation, incubation, illumination, and verification (Hadamard, 1945). The first of these stages, the initiation phase, consists of deliberate and conscious work. This constitutes a person's voluntary, and seemingly fruitless, engagement with a problem. Following the initiation



stage the solver, unable to come to a solution stops working on the problem at a conscious level (Dewey, 1933) and begins to work on it at an unconscious level (Hadamard, 1945; Poincaré, 1952). This is referred to as the incubation stage of the inventive process and it is inextricably linked to the conscious and intentional effort that precedes it. After the period of incubation a rapid coming to mind of a solution, referred to as illumination, may occur. The experience of illumination carries with it a large affective component (Liljedahl, 2005) in general and positive emotions (Barnes, 2000; Burton 1999; Rota, 1997) in particular. Colloquially it is often referred to as the AHA! experience or the EUREKA! experience. In what follows I will refer to the phenomenon interchangeably as illumination or AHA! After illumination the correctness of the emergent idea is evaluated during the fourth and final stage, verification.

So, although instances of creativity, discovery, and invention are often seen as being punctuated by the phenomenon of illumination, illumination is but one part of the process. Having said that, however, illumination is THE aspect of the process that sets creativity, discovery, and invention apart from the more ordinary, and more common, processes of solving a problem. Illumination is the defining characteristic, the marker that something remarkable has taken place. My question, which I aim to answer in this article, is – *if the phenomenon of illumination is the defining characteristic of creativity, discovery, and invention, then what is the defining characteristic of illumination?*

## Methodology

How does one collect meaningful data on a phenomenon as rare and as fleeting as illumination?

*And yet, the task is inherently difficult. The absence of sufficient knowledge on this topic is not a matter of a mere negligence on the part of researchers. There are at least two reasons why collecting direct observational data on AHA! seems like an impossible mission. First, being a private phenomenon, it is directly accessible only to the experiencing subject. Second, being defined as an experience that happens suddenly and “without warning,” it cannot be captured just when the observer has time and means to observe. These two difficulties, however, did not stop either Gestalt psychologists or the French mathematician Hadamard from tackling the issue. In both cases, the principal method of study was the subjects’ self-report on their problem-solving processes, provided a posteriori. (Sfard, 2004)*

And so it is in this article. Relying on the anecdotal reflections of prominent mathematicians I present the results a research study predicated on the resurrection of parts of Hadamard's seminal survey (1945). Hadamard's original questionnaire contained 33 questions pertaining to everything from personal habits, to family history, to meteorological conditions during times of work (Hadamard, 1945). From this extensive and exhaustive list of questions the five that most directly related to the phenomena I was interested in were selected. They are:

1. Would you say that your principle discoveries have been the result of deliberate endeavour in a definite direction, or have they arisen, so to speak, spontaneously? Have you a specific anecdote of a moment of insight/inspiration/illumination that would demonstrate this? [Hadamard # 9]
2. How much of mathematical creation do you attribute to chance, insight, inspiration, or illumination? Have you come to rely on this in any way? [Hadamard# 7]
3. Could you comment on the differences in the manner in which you work when you are trying to assimilate the results of others (learning mathematics) as compared to when you are indulging in personal research (creating mathematics)? [Hadamard # 4]
4. Have your methods of learning and creating mathematics changed since you were a student? How so? [Hadamard # 16]
5. Among your greatest works have you ever attempted to discern the origin of the ideas that lead you to your discoveries? Could you comment on the creative processes that lead you to your discoveries? [Hadamard # 6]

These questions, along with a covering letter, were then sent to 150 prominent mathematicians in the form of an email.

As discussed in the introductory sections, Hadamard set excellence in the field of mathematics as a criterion for participation in his study. In keeping with Hadamard's standards, excellence in the field of mathematics was also chosen as the primary criterion for participation in this study. As such, recipients of the survey were selected based on their achievements in their field as recognized by their being honoured with prestigious prizes or membership in noteworthy societies. In particular, the 150 recipients were chosen from the published lists of the Fields Medalists, the Nevanlinna Prize winners, as well as the membership list of the American Society of Arts & Sciences. The 25 recipients, who responded to the survey, in whole or in part, have come to be referred to as the participants in this study. Of these 25 participants all but one agreed to allow their name to appear alongside their comments.

After these participants supplied their responses to the aforementioned five questions they were sent a further two questions, again in the form of an email. These additional questions were designed to specifically focus on the phenomenon of illumination—again referred to as the AHA! experience. These questions were:

1. How do you know that you have had an AHA! experience? That is, what qualities and elements about the experience set it apart from other experiences?
2. What qualities and elements of the AHA! experience serve to regulate the intensity of the experience? This is assuming that you have had more than one such experience and they have been of different intensities.

The responses were initially sorted according to the survey question they most closely addressed. However, using affect as a basis of analysis, a second more intensive coding of the data was done using analytic induction (Patton, 2002).

*Analytic induction, in contrast to grounded theory, begins with an analyst's deduced propositions or theory-derived hypotheses and is a procedure for verifying theories and propositions based on qualitative data. (Taylor and Bogdan, 1984, p. 127)*

## Results

For reasons of brevity I present here only partial results from this analysis, organized under the three most relevant questions. For a more thorough presentation of results see Liljedahl (2008).

### Question One

Would you say that your principle discoveries have been the result of deliberate endeavour in a definite direction, or have they arisen, so to speak, spontaneously? Have you a specific anecdote of a moment of insight/inspiration/illumination that would demonstrate this? [Hadamard # 9]

With respect to this article, the second part of question one is most relevant. I asked the participants to provide a specific anecdote that demonstrated the role of insight, illumination, or inspiration. Many of the participants provided only partial anecdotes as to what it was they were doing at the moment of discovery: driving, sleeping, cooking, or showering.

*In my principle discoveries I have always been thinking hard trying to understand some particular problem. Often it is just a hard slog, I go round arguments time and again seeking for a hole in my reasoning, or for some way to formulate the problem/structures I see. Gradually some insights builds and I get to “know” how things function. But the main steps come in flashes of insight; something clicks into place and I see something clearly, not necessarily what I was expecting or looking for. This can occur while I am officially working. But it can also occur while I am doing something else, having a shower, doing the cooking. I remember that the first time I felt creative in math was when I was a student (undergrad) trying to find an example to illustrate some type of behaviour. I’d worked on it all the previous evening with no luck. The answer came in a flash, unexpectedly, while I was showering the next morning. I saw a picture of the solution, right there, waiting to be described. (Dusa McDuff)*

*That was the initial intuition, and in five minutes I knew it could be done and all the consequences it would entail. In conclusion, I think that for my best work I need intuition (or illumination, if it comes really suddenly) and also determination in reaching a goal [...] there have been occasions in which ideas came to me almost by chance or almost by themselves. For example, reading a paper one may see almost in a flash how to remove a stumbling block. (Enrico Bombieri)*

*And relevant ideas do pop up in your mind when you are taking a shower, and can pop up as well even when you are sleeping, (many of these ideas turn out not to work very well) or even when you are driving. Thus while you can turn the problem over in your mind in all ways you can think of, try to use all the methods you can recall or discover to attack it, there is really no standard approach that will solve it for you. At some stage, if you are lucky, the right combination occurs to you, and you are able to check it and use it to put an argument together. (Dan J. Kleitman)*

## Question Six

How do you know that you have had an AHA! experience? That is, what qualities and elements about the experience set it apart from other experiences?

In many ways the responses to this question were, in one form or another, definitions of the AHA! experience, all of which echo parts of the definition of creativity, discovery, and invention presented earlier on in the article. In some cases the participants focus on the suddenness with which an answer appears as the defining characteristic.

*When, after some considerable, quite non-productive effort, usually while not at all consciously working on the problem, there appears, for no apparent reason, in your brain the answer to that problem – that’s the AHA! experience. It can also happen when you are working on the problem, and then it is the apparent suddenness that generates the AHA! experience. (Connor)*

Others discuss the feeling of certainty that accompanies the AHA! experience.

*When an idea comes up that solves a hard problem that has been with you for a while you just know it is IT. You may need to do a lot of work to check that things do work out as you expect and this takes time. In some cases the real results are not quite what you wanted but it was still a good idea you had. In a few cases the results do work out all the way. (George Papanicolaou)*

Still, others focus on the significance of the discovery as the key element in the experience.

*What I think you mean by an AHA! experience comes at the moment when something mathematically significant falls into place. This is a moment of excitement and joy, but also apprehension until the new idea is checked out to verify that all the necessary details of the argument are indeed correct. (Wendell Fleming)*

However, most use a combination of suddenness, certainty, and significance in their descriptions of the phenomenon and what sets it apart.

*It is, in my experience, just like other AHA! experiences where you suddenly “see the light”. It is perhaps a little more profound in that you see that this is “important”. I find that as one gets older, you learn to recognize these events more easily. When younger, you often don’t realize the significance of such an event at the time. (Jerry Marsden)*

*A Eureka experience (I prefer this term) is characterized by suddenly realizing that you have found the missing piece of the jig-saw puzzle. Once found it is obviously right. (Michael Atiyah)*

*This is very subjective. I would say that crank science is often fueled by people who had some kind of “sudden vision” which for them becomes “absolute truth”. Anyway, I can compare the AHA! experience to putting together a very complicated puzzle without a blueprint, and suddenly you realize what it should be, and the pieces fall in the proper slot instantly. One does not need to*

*put all the pieces in their proper places. Once you get the idea, the vision where exactly the bridge should be built, you know right away the litmus test to apply in order to confirm it. (Enricho Bombieri)*

### Question Seven

What qualities and elements of the AHA! experience serve to regulate the intensity of the experience? This is assuming that you have had more than one such experience and they have been of different intensities.

Unlike question six, above, this question spawned a much wider array of responses. It seems that what regulates the intensity of the AHA! experience is much less definite than what separates it from other mathematical experiences. A theme that did emerge, however, was the role that time played in the intensity.

*The harder and more prolonged the prior work, and/or the more sudden and unexpected the insight, the more intense is the AHA! experience. To be sure, it is also possible (as I know from ultimately sad experience) to have AHA! experiences based on what turn out to be false insights. Certainly it is standard among mathematicians to enjoy these AHA! moments while they last and postpone for a bit (e.g., until the next day) the necessary checking of the insight. (Connor)*

*It depends how long one has worked, how many silly mistakes one made. Here's a good quote for you from Gelfand. Povzner says: "Gelfand cannot solve difficult problems. He only solves simple problems". Do you see? (Henry McKean)*

In his comments, Connor not only reflects on the role of time, but also revisits the role of suddenness, this time with respect to the intensity of the AHA! experience. He also contributes the idea that intensity of the conscious effort contributes to the eventual intensity of the AHA! experience. McKean also mentions the length of time that has been spent, as well as adding the comment about the number of silly mistakes. His quote with regards to Gelfand I find insightful and is reminiscent of a Gestalt philosophy of problem solving in which the problem is turned and turned until a 'simple' way of solving it is seen. This also introduces the dimension of simplicity as one of the regulators of intensity as described by George Papanicolaou.

*In the three or four cases where a clear advance was made (as pointed out last year in item 5) the degree to which the idea worked out as hoped for is*

*a measure of its importance and the satisfaction that it gives. Sometimes it is the simplicity of the idea or the ultimate simplicity of the results it gives. I have also noted that often the really important idea in solving a problem may be visible only to a very small number of readers. It is hard to see where the pressure points were in a well-solved problem, not because they are hidden or not spelled out but because of the relative simplicity and effectiveness of the approach followed. (George Papanicolaou)*

In this passage, Papanicolaou mentions not only the simplicity of the initial idea, but also the simplicity of the results it produces. This can often result in a simplification of the problem, or even the field within which the problem is embedded. The result of such simplification is that the initial hurdles that blocked progress may become indistinguishable to those who view the mathematics in its completed form. Simplification is not the only way in which an AHA! experience can affect understanding.

Another theme that reappeared in the responses to this question was with regards to significance.

*The intensity is of course regulated by the magnitude of the new insight, and/or the desperateness before. Also I should mention that these experiences are not so uncommon, but many of them do not last long because often the new insight later turns out to be false. (Gerd Faltings)*

*The depth of the experience depends on how profound the ultimate result is. Sometimes the experience is easy to remember in retrospect because it happened during a particular walk, either alone or in company. (Michael Atiyah)*

## Discussion

The main themes that emerged out of the aforementioned results all come out of how the mathematicians talk about their experiences. The first has to do with the absence of the particulars of mathematical ideas from the mathematicians' stories. This is exemplified nicely in Dusa McDuff's response to question one. Although the details of the mathematics are missing the essence of the experience remains. There is an aboutness of the mathematical ideas involved that is reminiscent of the way Poincaré (1952) talked about his experiences.

*I must apologize, for I am going to introduce some technical expressions, but they need not alarm the reader, for he has no need to understand them. I shall*

*say, for instance, that I found the demonstration of such and such a theorem under such and such circumstances; the theorem will have a barbarous name that many will not know, but that is of no importance. What is interesting for the psychologist is not the theorem but the circumstances (p. 52).*

And the circumstances were interesting. Almost all of the mathematicians surveyed highlighted in their anecdotes the context of their experience, and they do so in the absence of any mathematical details. It is almost as though the ideas themselves are ancillary to the experience of illumination.

*While at a meeting in Philadelphia, I woke up one morning with the right idea. (Dick Askey)*

*And relevant ideas do pop up in your mind when you are taking a shower, and can pop up as well even when you are sleeping, (many of these ideas turn out not to work very well) or even when you are driving. (Dan J. Kleitman)*

*In regard to illumination, I would like to add that in my case the best instances have been at night when I am laying in bed, somewhere between consciousness and sleep. (Demetrios Christodoulou)*

*I distinctly remember the moment early in our collaboration when I saw how to get past one of the major technical difficulties. This happened while walking across campus after teaching a class. (Wendell Fleming)*

*It may have been in the shower that it just occurred to me that the work of some of the classical authors could be generalized in a certain way [...] I can be talking to a colleague or my wife or eating breakfast and suddenly, like a voice from the blue, I get told what to do. (Jerry Marsden)*

*The overt work is much the same as it always was. The covert work (in bed, on the subway, in dreams) is harder now. (Henry McKean)*

*I'm convinced that I do my best work while asleep. The evidence for this is that I often wake up with the solution to a problem, or at least with a clear idea of how to proceed to solve it. (Charles Peskin)*

Further, when talking about the nature of the ideas that occur at the moment of illumination, the mathematicians commented on attributes such as certainty, significance, and simplicity. More accurately, they commented on a sense of certainty, a sense of significance and a sense of simplicity. Certainty, significance,



and simplicity are absolute statements that can only be ascertained through verification (Hadamard, 1945)—a process that transcends the immediacy of illumination. For these mathematicians, however, the experience of having a sense of certainty, significance, or simplicity is a very real aspect of illumination.

## Conclusions

So what are the defining characteristics of illumination? How is it differentiated from other mathematical experiences? For the mathematicians surveyed in this study what sets illumination apart is not the ideas themselves, but rather the way in which the ideas appear—suddenly and without any prior warning. The untimely and unanticipated presentation of an idea or solution while walking, or cooking, or showering filled them with a sense of certainty, significance or simplicity. These senses are subjective ... and they are affective. Indeed, the modifier sense can be replaced with the modifier feeling without any loss of meaning or implication. So, while the cognitive components are not absent from the experience of illumination—after all, it is the arrival of an idea that punctuates the phenomenon—the aspects of illumination that sets the experience apart from other mathematical experiences are affective in nature.

## References

- Barnes, M. (2000). 'Magical' moments in mathematics: Insights into the process of coming to know. *For the Learning of Mathematics*, 20(1), 33-43.
- Burton, L. (1999). The practices of mathematicians: What do they tell us about coming to know mathematics? *Educational Studies in Mathematics*, 37(2), 121-143.
- Davis, P., & Hersch, R. (1980). *The mathematical experience*. Boston: Birkhauser.
- Dewey, J. (1933). *How we think*. Boston, MA: D.C. Heath and Company.
- Fischbein, E. (1987). *Intuition in science and mathematics: An educational approach*. Dordrecht, Holland: Kluwer Academic Publishers Group.
- Ghiselin, B. (1952). *The creative process: Reflections on invention in the arts and sciences*. Berkeley, CA: University of California Press.
- Hadamard, J. (1945). *The psychology of invention in the mathematical field*. New York: Dover Publications.
- Liljedahl, P. (2008). *The AHA! Experience: Mathematical Contexts, Pedagogical Implications*. Saarbrücken, Germany: VDM Verlag.
- Liljedahl, P. (2005). Mathematical discovery and affect: The effect of AHA! experiences on undergraduate mathematics students. *International Journal of Mathematical Education in Science and Technology*, 36(2-3), 219-236.

- Nova (1993). The proof. Aired on PBS on October 28, 1997. Retrieved December 11, 2003 from: <http://www.pbs.org/wgbh/nova/transcripts/2414proof.html>.
- Patton, M. Q. (2002). *Qualitative research and evaluation methods*. Thousand Oaks, CA: Sage.
- Perkins, D. (2000). *Archimedes' bathtub: The art of breakthrough thinking*. New York, NY: W.W. Norton & Company.
- Poincaré, H. (1952). *Science and method*. New York: Dover Publications, Inc.
- Pólya, G. (1965/1981). *Mathematical discovery: On understanding, learning and teaching problem solving (vol. 2)*. New York, NY: Wiley.
- Rota, G. (1997). *Indiscrete thoughts*. Boston, MA: Birkhauser.
- Sfard, A. (2004). *Personal Communication*.
- Taylor, S. J., & Bogdan, R. (1984). *Introduction to qualitative research methods: The search for meanings*. New York: John Wiley & Sons.
- Wallas, G. (1926). *The Art of Thought*. New York, NY: Harcourt Brace.



**ELEMENTARY TEACHERS' VIEWS OF  
MATHEMATICS AND ITS TEACHING**



## Inside teachers' affect: teaching as an occasion for math-redemption

CRISTINA COPPOLA, PIETRO DI MARTINO, TIZIANA PACELLI AND  
CRISTINA SABENA

ccoppola@unisa.it  
University of Salerno, Italy

### Abstract

*Mathematics education is strongly interested in defining "what is necessary for teaching mathematics effectively". The main directions of research emphasize the cognitive side of the answer to this question, trying to describe what kind of knowledge is needed in order to teach mathematics effectively. Starting from the point that teachers' affect plays a crucial role in determining the quality of teaching, we discuss this issue from a theoretical point of view, describing our perspective in detail and introducing the construct of "attitude towards mathematics teaching". We discuss some of the results of a study we conducted in order to investigate the attitude towards mathematics and its teaching of 189 primary school pre-service teachers. In particular, we focus on the emotional component, describing what we call the "math-redemption" phenomenon.*

### Keywords

*attitude towards mathematics, attitude towards mathematics teaching, teachers' training, math-redemption*

### Introduction

*Historians predict that unless we examine and learn from the past we are condemned to relive it. It appears that their prediction may be in the process of fulfilment in the area of mathematics education (Mihalko 1978, p.35).*

This was the incipit of the work of Mihalko about mathematics teacher education more than thirty years ago. He described a cycle that it is not difficult to recognize also nowadays in many countries: students' performance in mathematics below public expectations, cries of indignation, rethinking of the way to introduce mathematics in classroom (with an abuse of the label "new math"), implementation of the "new math" in the curriculum, poor results obtained

and so on. Mihalko underlined that the introduction of “new math” in school curriculum is usually more virtual than real because it is not accompanied by an adequate teacher preparation. Consequently, he began to discuss the meaning of “adequate teacher preparation” recognizing cognitive and affective goals:

*In the cognitive area we need a teacher education curriculum which assures knowledge and competency in mathematics as well as a knowledge of the philosophical, historical, psychological, and sociological aspects of education. In the affective area we need a stimulus for the growth of teachers' ability and desire of knowledge (Mihalko ibidem, p.36).*

In some sense he can be seen as a precursor in the field about teachers' professional development in mathematics education: for the first time the awareness of the need of a deep reflection about “what is necessary for teaching mathematics effectively” was made explicit.

About ten years later, Shulman (1986) developed his very famous perspective that recognized three different components of knowledge necessary for teaching: Curricular Knowledge (CK), Subject Matter Knowledge (SMK) and Pedagogical Content Knowledge (PCK). PCK represented the real innovation: a knowledge “which goes beyond knowledge of subject matter per se to the dimension of subject matter knowledge for teaching” (Shulman ibidem, p.9).

Shulman's perspective has had a great impact on the research about teachers in mathematics education, having inspired many important studies in the field: Ball and Bass (2003) explicitly referred to Shulman's work in the development of their theory of Mathematical Knowledge for Teaching (MKT). The work of Ball and Bass has also many links with the pioneering work of Mihalko, since they share the starting educational problem, the working assumption and the reformulation of the problem with a shift of attention from students to teachers:

*We seek in the end to improve students' learning of mathematics (...) We focus on teacher knowledge based on the working assumption that (...) the goal of improving students' learning depends on improving teachers' knowledge (...) The problem: what mathematics do teachers need to know to teach effectively? (Ball & Bass ibidem, p.3).*

Based on the shared assumption that the quality of students' learning is related to the teacher knowledge, Ball and Bass's perspective about mathematics teacher development refers exclusively to the cognitive aspect. But, according to Zembylas (2005, p.467, emphasis as in original):

*Teacher knowledge is located in 'the lived lives of teachers, in the values, beliefs, and deep convictions enacted in practice, in the social context that encloses such practices, and in the social relationship that enliven the teaching and learning encounter'. These values, beliefs and emotions come into play as teachers make decisions, act and reflect on the different purposes, methods and meanings of teaching.*

This view supports our strong conviction that the answer to the question “what is necessary for teaching mathematics effectively” cannot be limited to what teachers know and that it must include considerations about what teachers believe and feel. As underlined in what may be considered the initial manifesto of the modern research on affective factors in mathematics education: “All research in mathematics education can be strengthened if researchers will integrate affective issues into studies of cognition and instruction” (McLeod 1992, p.575).

## Teachers' affect: theoretical framework

Since the early research in the field of affect, the interest about teachers' beliefs, emotions and attitudes in mathematics is mainly motivated by the conviction that these factors influence teachers' practice and then strongly affect the quality of students' learning in mathematics: “the teacher's attitude is a potent force in the classroom” (Burton 1979, p.131).

Initially the focus of the research was placed on finding – through quantitative studies – cause-effect relationships between affective factors held by a teacher and his/her classroom practice. This approach is problematic and lead to inconsistent or even contradictory results: for example the problem of the inconsistency between beliefs professed by teachers and their practice is well-known (Di Martino & Sabena 2010).

In the nineties, the research on affect in mathematics education developed through a shift from a normative-positivistic paradigm, to an interpretative one (Zan et al. 2006). A gradual affirmation of the interpretative paradigm in social sciences, related to a greater attention towards aspects of the complexity of human behavior, has led researchers in mathematics education to abandon the attempt of explaining behavior through measurements or general rules based on a cause-effect scheme, and to search for new interpretations. After this change of paradigm, there was a growing awareness among mathematics educators of the central role of affect in mathematics learning and teaching (Tsamir & Tirosh 2009). But, as Philipp (2007, p.309) underlines, there is a great imbalance between research on teachers' beliefs, and research on teachers' emotions:



*One noteworthy difference between research on teachers' beliefs and affect is that whereas research on teachers' beliefs has been extensive and subsumed into almost all areas of research on mathematics teaching and learning, the study of teachers' affect has not.*

Actually, this imbalance is not peculiar only to mathematics education:

*Despite the enormous blossoming of psychological research on emotions since the early 1980s, little of this work has informed current research on teachers (...) Researchers also know little about how teachers regulate their emotions, the relationship between teachers' emotions and motivation, and how integral emotional experiences are in teacher development (Sutton & Wheatley 2003, p.328).*

The research about teachers' emotions in mathematics education has mainly focused on primary pre-service teachers, in particular studying and well-documenting the problem of primary teachers' negative emotions (anxiety, fear, etc.) towards mathematics (Wood 1987; Hannula et al. 2007; Di Martino & Sabena 2011). Many researchers stress the importance of preventing or overcoming these negative emotions as a necessary condition to improve the quality of mathematical learning:

*[Mathematics teachers] cannot be expected to generate enthusiasm and excitement for a subject for which they have fear and anxiety. If the cycle of mathophobia is to be broken, it must be broken in the teacher education institution (Mihalko ibidem, p.36).*

Our conviction is that interpreting (and counteracting) the phenomenon called mathophobia needs to consider teachers' affect in its entirety. From this point of view, if Philipp (ibidem) stresses the complete lack of integration between the research on teachers' emotions and the research on teachers' beliefs, many scholars give theoretical emphasis to the strong relationship between beliefs and emotions (Hannula 2009). In particular, Di Martino and Zan (2010; 2011) consider this relationship at the basis of their three-dimensional model of attitude (TMA model, Figure 1). In their view, attitude towards mathematics is characterized by three strictly interrelated dimensions: emotional disposition towards mathematics, view of mathematics and perceived competence in mathematics:

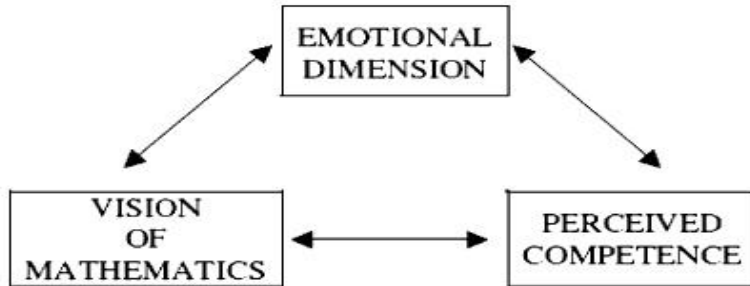

Figure 1. *The Three-dimensional Model of Attitude* (Di Martino & Zan, 2010).

Within the interpretative paradigm, Di Martino and Zan's theoretical research fits with the strong incentive "to develop constructs that might be applied to help make sense of teaching and learning environments" (Philipp *ibidem*, p.264). In this paradigm the single affective construct is no longer a trait of the observed subject, predictive for his/her behaviors, but instead it is a model of the observer, useful to interpret and understand processes of teaching and learning (Ruffel et al. 1998).

In this framework, research in mathematics education has underlined that to analyze teachers' affect it is necessary to consider not only their attitude towards mathematics but also towards its teaching (Relich, Way & Martin 1994, p.56).

According to this view, we have extended the model of attitude, considering also teacher's emotional disposition, view and perceived competence towards mathematics teaching. We conducted a study focused on primary pre-service teachers' attitude towards mathematics and its teaching. The study has a twofold goal: on the one hand – as teachers' educators – to help future teachers becoming aware of the attitudes that they hold (it is the first step towards an eventual change), on the other hand – as researchers – to investigate the six dimensions involved in attitude towards mathematics and attitude towards its teaching and their mutual relationships.

In this paper, we focus and discuss in particular about emotional component: in the Italian context, as discussed in previous study (Di Martino & Sabena 2011), primary pre-service teachers have often very negative emotions towards mathematics.

We think that it is important to investigate the relationship between pre-service teachers' emotions towards mathematics and two different aspects: their past experiences as math-students and the emotions elicited in knowing that they have to teach mathematics in future.

## Methodology

The sample of the study is represented by 189 future primary school teachers of two different Italian Universities: a small University in the South and a bigger one in the North. The subjects were enrolled in the courses on Mathematics and its Teaching that take place during the first year of the University degree for primary school teachers.

We developed an open questionnaire on the basis of the evaluation of the results gained with questionnaires used in previous researches with primary pre-service teachers (Di Martino & Sabena, 2010; 2011). The questionnaire was administered in the very first lesson of the course at both the Universities in the a.y. 2011-2012. Respondents were asked to answer anonymously, providing a nickname. The used questionnaire is composed by 12 questions focused on the three components of attitude (according to the TMA model), declined along the two dimensions of mathematics and its teaching. The questions can be organized into the six resulting factors as showed in Table 1.

The questionnaire is oriented to capture relationships and dynamics developing over time. In particular, we were interested in seizing links between the past experience as students (e.g. Question 5) and the perspective towards the future teaching (questions 10-12). Present is of course pervasive, since every answer is filtered by the subjects' present views and emotions.

In this paper, we analyze the answers to Questions 4,5 and 10, related to the emotional dispositions towards mathematics and towards its teaching.

For what concern the methodology of analysis, descriptive statistics was used as an analytical tool to gain insights into the data. Dubar & Demaziere (1998) proposed an approach, called analytical, in order to systematically produce sense from people's words. Final outcome of this analytical process is the construction of a set of categories, properties, and relationships.

*Table 1. The questionnaire questions' categorization according to the developed model.*

	<i>Mathematics</i>	<i>Mathematics teaching</i>
Emotional disposition	<p>4. Write three emotions you associate to the word "mathematics".</p> <p>5. How was your relationship with mathematics as a student?</p> <p>Positive Negative Indifferent Ups and downs</p> <p>Explain why you think that your relationship was so.</p>	<p>10. Which emotions do you feel in knowing that you will have to teach mathematics? Why?</p>
View	<p>1. Write three adjectives you associate to the word "mathematics".</p> <p>2. What is, in your opinion, a positive feature of mathematics? Why do you think so?</p> <p>3. What is, in your opinion, a negative feature of mathematics? Why do you think so?</p> <p>6. Indicate three qualities you consider necessary in order to succeed in mathematics.</p> <p>8. For which reasons, in your opinion, can students have bad results in mathematics?</p> <p>9. In your opinion, why is it important that mathematics is taught at school?</p>	<p>12. Which characteristics should have in your opinion, a "good" mathematics teacher?</p>
Perceived competence	<p>7. In which measure do you think to have the qualities written in the previous answer?</p>	<p>11. Try to describe some difficulties you expect to meet in teaching mathematics.</p>

## Results

We based our analysis of the answers to the question related to the emotional disposition, on the work of Ortony, Clore and Collins (1988) about the cognitive origin of the emotions. They describe emotions as "valenced reactions" to consequences of events, action of agents, or aspects of objects. They classify the first class of reactions (to events) in being pleased and displeased, the second

class of reactions (to agents) in approving and disapproving, and the latter (to objects) in liking and disliking.

We use these dichotomies for a first rough classification into positive/negative emotions coming from the answers to Question 4 and Question 10, but in our analysis we consider Ortony, Clore and Collins' s view that:

*An analysis of emotion must go beyond differentiating positive from negative emotions to give a systematic account of the qualitative differences among individual emotions such as fear, envy, anger, pride, relief, and admiration (Ortony et. al ibidem, p. 12).*

The analysis of Question 4 (Q4) reveals a predominance of negative emotions (*anxiety, fear, panic*) elicited by mathematics with respect to the positive ones (*satisfaction, enjoyment, curiosity*). This predominance emerges both in terms of numerical occurrence (the 28% of the sample expresses only negative emotions in his/her answers, while the 20% expresses only positive emotions towards mathematics), and in the intensity (for example *panic* appears to be hottest than *curiosity* or *satisfaction*).

Q5 asks future teachers to give a judgment on their personal relationship with mathematics, and to provide an explanation. Respondents can be divided into the four groups provided by the questionnaire: **Positive Relationship (PR: 23%)**, **Negative Relationship (NR: 16%)**, **Indifferent Relationship (IR: 1%)**, and **Fluctuating Relationship (FR: 60%)**. In this case, no questionnaire is left unanswered; moreover almost all the respondents provide detailed descriptions of their relationship with maths: the past relationship with mathematics appears something on which future teachers have much to tell. By a qualitative analysis of these rich answers we can categorize the perceived causes of such relationship (in some case the recognized causes are more than one). In particular, comparing the answers in the *extreme* groups (i.e. the **PR** and the **NR**) we obtain the data summarized in Table 2.

Table 2. *Perceived causes for the relationship with maths.*

<i>Declared causes for the relationship with maths at school</i>	
<i>Positive Relationship Group</i>	<i>Negative Relationship Group</i>
Teacher (60%)	Teacher (52%)
Innate characteristics (5%)	Innate characteristics (40%)
Success and its emotional consequences (23%)	Failure and its emotional consequences (36 %)
Interest in the discipline (17%)	Disinterest in the discipline (16%)

Focusing on similarities and differences between the two columns of Table 2 we observe that:

- in both groups the majority of respondents recognizes in one of their school teacher the main factor in the determination of their own relationship with maths at school;
- in the **NR**-group a great relevance is given also to attributed innate “limiting” characteristics (for example, Elilee writes “*Surely this is because I am limited and more inclined to the humanities*”) whereas this aspect is little mentioned in the **PR**-group, roughly 5%;
- the relationship with mathematics is often identified also with the success or failure experiences and their emotional burden. This aspect appears strong both in the positive (for example, Minu writes: “*I always liked the sense of satisfaction felt when I solve a problem*”) and in the negative cases (as an example June answers: “*Besides my difficulty in following and understanding maths, a strong sense of anxiety has accompanied me every time there was a maths test in classroom*”), confirming that the emotional disposition and the perceived competence dimensions are deeply intertwined.

As this brief discussion shows, the analysis of Q5 provides insights on another dimension of the TMA model: respondent’s view of mathematics teaching. In fact, their narrative accounts shed light on what they consider good and bad qualities of mathematics teachers. With this regard, two main features emerge as crucial and pervasive in both the **PR** and the **NR** groups: to be able/unable in helping the students to understand mathematics (cognitive dimension); to be able/unable in transmitting the love for mathematics (affective dimension).

Analyzing the answers to Q10 we observe that those respondents that are in **PR**-group and declare positive emotions towards maths declare also positive feelings towards the idea of having to teach maths.

In the case of negative relationship or negative emotional disposition towards mathematics, the correlation with emotional disposition towards its teaching is not unidirectional. As a matter of fact many respondents that declare negative emotions towards mathematics (Q4) or a negative relationship in the past with it (Q5), display positive feelings related to the perspective of having to teach it. Indeed the 40% of the sample declare a positive emotional disposition towards the idea having to teach mathematics compared with the 30% that is scared by the same perspective.

In our opinion, it is very significant that the most used word in the answers to this question is: responsibility. In many cases, the difficulties met in the personal school experience are considered as the main stimulus for the future work (Nadi, for example, writes: *"It is exciting to think that I might give children what had not been given to me"*). However, in other cases, the negative past experience appears to be the origin of rooted and precise beliefs about mathematics teaching that influence negatively the perspective of teaching mathematics. These beliefs appear to be closely related with the view of mathematics teaching emerging from answers to Q5, highlighting the fear to be unable in helping the students at a cognitive level (as an example Cielo affirms: *"I feel anxiety because I might not be able to transmit the love for the subject"*) and in conveying the pleasure to do maths on an affective level (in the protocol of Camilla 89 we can read: *"I am discouraged because I do not feel able to explain to a child topics as multiplication tables, division that I now consider routine"*).

Moreover, some people with negative relationship with mathematics see in the perspective of teaching a possibility for *redeeming* themselves in their relationship with mathematics, whereas others, on the contrary, declare to feel insecure in accomplish a work that they consider important but difficult.

As a matter of fact, almost all the respondents consider teaching of mathematics a very difficult challenge, but there is a clear distinction between those that see it as a stimulating challenge, and those that see it as an insurmountable obstacle. In the latter case, strong negative emotions are elicited by the idea of having to teach mathematics. This remark highlights that negative feelings towards the perspective of having to teach maths are strongly influenced by a low perceived competence towards mathematics as, for example, it emerges from Nello's protocol: *"Fear, because I have not the necessary basis of mathematics for teaching it"*.

But the same negative feelings are also associated to a low perceived competence towards mathematics teaching, as for example in RedQueen's protocol: *"Fear, because I would like to transmit my passion to other people, but I fear not to find suitable methods to be effective"*.

## Conclusions

As teacher educators we have a dual goal: a research-goal that is to understand and recognize the most significant variables involved in the process of teachers' development, and an educational-goal that is to promote teachers' growth.

These goals are clearly related and linked to the answer to the question “what do maths teachers need to teach effectively?”

Starting by the perspective that knowledge is only one side of the coin, and by the documented and alarming phenomenon of negative feelings towards mathematics (and sometimes towards its teaching) of primary pre and in-service teachers, we are interested in conducting theoretical and empirical studies to interpret this phenomenon and to recognize its causes. It is important to know the phenomenon, to study its effect on teachers practice and, on the basis of this, to develop strategies to overcome difficult experiences.

Some interesting outcomes emerge by the preliminary analysis of pre-service teachers' answers to our questionnaire. First, the awareness of the role of the school-teacher in their relationship with mathematics comes out as a fundamental topic. Another very significant issue coming from our analysis is the desire for math-redemption expressed by many respondents among those who declare negative past relationship with mathematics. This is a central point, because as teacher educators we have the chance of leveraging this desire to break the chain connecting the negative past school experiences with the negative feelings towards mathematics of many primary pre-service teachers. Moreover, we can observe, from our analysis, that the degree of confidence about the possibility of math-redemption is strictly linked to both cognitive aspects (PCK, SMK) and affective ones.

Mathematics teacher education is a quite recent field of research in mathematics education: the first Handbook of Mathematics Teacher Education was published in 2008 by Sullivan and Wood. As we read in the preface of this handbook, “most research papers in mathematics teacher education put a major focus on the content dimension” and there is very little literature about teachers affect.

Thirty years after the famous paper by Schoenfeld (1983), we are convinced that there is the need to go beyond the purely cognitive also in the research about mathematics teacher education, and to explore teachers' affect in its wholeness.

## References

- Ball, D. L., & Bass, H. (2003). Toward a practice-based theory of mathematical knowledge for teaching. In B. Davis & E. Simmt (Eds.), *Proceedings of the 2002 Canadian Mathematics Education Study Group* (p. 3-14). Edmonton, AB: CMESG/GCEDM.



- Burton, G. (1979). Comfortable with Mathematics. *The Elementary School Journal*, 79(3), 129-135.
- Dubar, C., & Demazière, D. (1998). *Analyser les entretiens biographiques*, Paris: Nathan.
- Di Martino, P., & Sabena, C. (2010). Teachers' beliefs: the problem of inconsistency with practice. In M. Pinto & T. Kawasaki (Eds.), *Proceedings of the XXXIV Conference of the International Group for the Psychology of Mathematics Education*, vol. 2, 313-320.
- Di Martino, P., & Sabena, C. (2011). Elementary pre-service teachers' emotions: shadows from the past to the future. In K. Kislenko (Ed.), *Current state of research on mathematical beliefs XVI*, Tallinn University, 89-105.
- Di Martino, P., & Zan, R. (2010). 'Me and maths': towards a definition of attitude grounded on students' narratives. *Journal of Mathematics Teachers Education*, 13(1), 27-48.
- Di Martino, P., & Zan, R. (2011). Attitude towards mathematics: a bridge between beliefs and emotions. *ZDM - The International Journal on Mathematics Education*, 43(4), 471-482.
- Hannula, M. (2009). Affect in mathematical thinking and learning: towards integration of emotion, motivation and cognition. In J. Maaß and W. Schölglmann (Eds.), *Beliefs and attitudes in mathematics education: New Research Results* (pp. 209-232). Rotterdam, the Netherlands: Sense Publishers.
- Hannula, M., Liljedahl, P., Kaasila, R., & Rösken, B. (2007). Researching relief of mathematics anxiety among pre-service elementary school teachers. In W. Jeong-Ho, L. Hee-Chan, P. Kyo-Sik, S. Dong-Yeop (Eds.), *Proceedings of XXXI Conference of the International Group for the Psychology of Mathematics Education*, vol. 1, 153-156.
- McLeod, D. B. (1992). Research on affect in mathematics education: A reconceptualization. In D. A. Grouws (Ed.), *Handbook of research on mathematics teaching and learning: A project of the NCTM* (pp. 575-596). New York: Macmillan.
- Mihalko, J. C. (1978). The answers to the prophets of doom: mathematics teacher education. In D. B. Aichele (Ed.), *Mathematics teacher education: critical issues and trends* (pp. 36-41). Washington, DC: National Education Association.
- Ortony, A., Clore, G. L., & Collins, A. (1988). *The cognitive structure of emotions*. Cambridge, England: Cambridge University Press.
- Philipp, R. A. (2007). Mathematics teachers' beliefs and affect. In F. K. Lester (Ed.), *Second Handbook of Research on Mathematics Teaching and Learning* (pp. 257-315). Reston, VA: NCTM.

- Relich, J., Way, J., & Martin, A. (1994). Attitudes to teaching mathematics: Further development of a measurement instrument. *Mathematics Education Research Journal*, 6, 56-69.
- Ruffell, M., Mason J., & Allen B. (1998). 'Studying attitude to mathematics', *Educational Studies in Mathematics*, 35, 1-18.
- Schoenfeld, A. (1983). Beyond the purely cognitive: Belief systems, social cognitions, and metacognitions as driving forces in intellectual performances. *Cognitive Science*, 7, 329-363.
- Shulman, L. S. (1986). Those who understand: Knowledge growth in teaching. *Educational Researcher* 15, 4-14.
- Sullivan, P., & Wood, T. (Eds.) (2008). *Knowledge and Beliefs in Mathematics Teaching and Teaching Development*. Rotterdam/Taipei: Sense Publishers.
- Sutton, R., & Wheatley, K. (2003). Teachers' emotions and teaching: A review of the literature and directions for future research. *Educational Psychology Review*, 15(4), 327-358.
- Tsamir, P., & Tirosh, D. (2009). Affect, subject matter knowledge and pedagogical content knowledge: the case of a kindergarten teacher. In J. Maaß & W. Schölglmann (Eds.), *Beliefs and attitudes in mathematics education: New Research Results* (pp. 19-32). Rotterdam, the Netherlands: Sense Publishers.
- Wood, E. (1987). Math anxiety and elementary teachers: What does research tell us? *For the Learning of Mathematics*, 1(1), 8-13.
- Zan, R., Brown, L., Evans, J., & Hannula, M. (2006). Affect in mathematics education: An introduction. *Educational Studies in Mathematics*, 63(2), 113-121.
- Zembylas, M. (2005). Beyond teacher cognition and teacher beliefs: the value of the ethnography of emotions in teaching. *International Journal of Qualitative Studies in Education*, 18(4), 465-487.



## Pre-service teachers' possible mathematical identities

SONJA LUTOVAC<sup>1</sup> AND RAIMO KAASILA<sup>2</sup>

sonja.lutovac@triera.net

<sup>1</sup>University of Lapland, Finland

<sup>2</sup>University of Oulu, Finland

### Abstract

*In the research on identity, future orientation has been overlooked. Additionally, insufficient cross-cultural knowledge has been provided on the issue in an elementary teacher education context. Here we attempt to understand pre-service teachers' future-oriented mathematical identity work by comparing one Finnish and one Slovenian case, who reported having had negative experiences with mathematics during their school years. On the basis of the results we identified two substantially different types of mathematical identity work. It seems that the main reasons for these differences are the different emphases in mathematics education courses, as well as in teacher education programs.*

### Key words

*mathematical identity work, future orientation, teacher education*

### Introduction

During the last decade, identity has been analysed extensively in teacher education research (for the review see Beauchamp & Thomas, 2009; Beijaard, Meijer & Verloop, 2004), as well as in mathematics education context (Sfard & Prusak, 2005; Black, Mendick & Solomon, 2009; Kaasila, 2007; Lutovac & Kaasila, 2011). Identity work, however, has been considered much less frequently. We discussed recently (Lutovac & Kaasila, 2011) that it has additionally remained broadly defined. Here we draw a distinction between identity and identity work. Identity is seen as “who or what someone is, the various meanings people can attach to themselves, or the meanings attributed by others” (Beijaard, 1995, p.282). We see that identity in teacher education context revolves around its narrative aspect and the ways in which narratives shape and are shaped by identity (cf. Beauchamp & Thomas, 2009). Further, constructing narratives is seen as ‘doing identity work’

(Watson, 2006, p. 525). In our view pre-service teachers' narratives thus provide an opportunity for exploring and revealing both concepts in mathematics context.

Our study continues and develops Finnish research tradition of studying pre-service teachers' beliefs, views of mathematics and their mathematical identities (see e.g. Hannula, 2007; Pehkonen & Hannula, 2004; Kaasila, 2007; Kaasila, Hannula, Laine & Pehkonen, 2008; Lutovac & Kaasila, 2011; Kaasila, Hannula & Laine, 2012) by focusing on identity work. Furthermore, this is the first study considering a Slovenian pre-service teacher's identity and identity work in mathematics education research.

Recently, the lack of future orientation when exploring teacher identity has been addressed (Hamman, Gosselin, Romano & Bunuan, 2010; Urzua & Vasquez, 2008), also specifically with respect to mathematics education (Di Martino & Sabena, 2011). Understanding pre-service teachers' identities as narratives has mostly foregrounded past and present dimensions of identity (Kaasila, 2007; Black et al., 2009). However, we see that in narratives, pre-service teachers also verbalize their reflective future-oriented thoughts (cf. Urzua & Vasquez, 2008). Therefore, our aim here is to analyze how two pre-service elementary teachers are within their narratives anticipating their possible future identities (cf. Markus & Nurius, 1986; Hamman et al., 2010) as mathematics teachers. Further, these pre-service teachers reported having had negative experiences with mathematics during their school years. We thus emphasize the emotions towards future teaching, which have been less researched to this point (Di Martino & Sabena, 2011). Additionally, earlier studies have not provided cross-cultural knowledge as a basis for the development of teacher education and mathematics education. Our two cases are broadening the cultural context; one attending Finnish and one Slovenian university.

There are some differences in educational policies and practices between Finland and Slovenia. Briefly, elementary teacher education programs are one of the most popular in Finland and students must be highly motivated to succeed in rigorous entrance examinations. In Slovenia, teaching profession is not highly regarded, neither are entrance examinations so rigorous. In Finland, pre-service teachers' professional knowledge, as well as their personal beliefs and experiences are emphasized. For that purpose, reflection skills (see e.g., Kaasila & Lauriala, 2012) and narratives are central in the process of becoming a teacher (Lutovac & Kaasila, 2011). In Slovenia, pre-service teachers' autobiographical context has not yet been given much attention (see Lutovac & Kaasila, 2009, 2010).

## Theoretical framework

### Narrative mathematical identity and mathematical identity work

Identity has been explored in different ways within the teacher education literature (Beauchamp & Thomas, 2009), likewise the concept of 'mathematical identity' (Kaasila, 2007; Sfard & Prusak, 2005; Black et al., 2009). Here we are applying Ricoeur's (1992) concept of narrative identity, agreeing that people often develop their sense of identity by seeing themselves as protagonists in different stories. Drawing from Ricoeur (1992), we see mathematical identity as a narrative construction, and as such, a product of reflective processes. We understand pre-service teachers' mathematical identity in terms of the narratives they create to explain themselves in relationship to mathematics and their mathematical lives (cf. Kaasila, 2007; Sfard & Prusak, 2005). Finally, we define mathematical identity as a set of stories pre-service teachers tell themselves or others about themselves as mathematics learners and teachers (Kaasila, 2007). These stories carry various meanings pre-service teachers attach to themselves as mathematics learners and teachers, or the meanings attributed by others (cf. Beijaard et al., 2004). Important part of mathematical identity is the view of mathematics, consisting of one's knowledge, beliefs, conceptions, attitudes, and emotions (see e.g. Kaasila et al., 2008).

For us, pre-service teachers' stories about mathematics are closely related to their ongoing mathematical identity construction (e.g., Kaasila, 2007; Lutovac & Kaasila, 2011). Narration is considered to be a major way in which people make sense of experiences, construct the self, and create and communicate meaning (Polkinghorne, 1995). In fact, this is what we understand as identity work. Therefore identity work thus involves the construction and reconstruction of meaning through stories over time (cf. Beijaard et al., 2004). We see that when pre-service teachers construct narratives from their experiences with mathematics, they are doing mathematical identity work and in turn construct their mathematical identities. Earlier we conceptualized mathematical identity work as a narrative process including an interaction between the individual and the social mathematical context; a process of self-reflection where past, present and future mathematical identities enter into a dialog. This leads to one's awareness of a tension or gap between the actual and the ideal state of mathematical identity. (Lutovac & Kaasila, 2011; see also Krzywacki & Hannula, 2010) The presence of a gap is of key importance for evoking teacher change processes.

## Future orientation: possible identities

When considering identity, pre-service teachers do not limit their thoughts to the present moment; rather, current identity is commonly understood as extending to past and future selves (cf. Ricoeur, 1992). We see that pre-service teachers create possible selves (Markus & Nurius, 1986), which were defined as views about what one might become, what one would like to become, and what one is afraid of becoming in the future. Such future views about oneself can be very motivating. Further, we are here examining pre-service teachers' narrated possible selves, which have been shown to be a particularly rich source of identity information. Because possible selves bridge the present and future, specifying how pre-service teachers may develop, we see that possible selves are central when considering pre-service teachers' future-oriented identity work (cf. Dunkel & Anthis, 2001). Additionally, because possible selves are created within an individual's social and cultural context, they are likely to be derived from it (Hamman et al., 2010). The latter seems particularly useful when considering intercultural similarities and differences in pre-service teachers' identity work.

## Methodology

### Focus of the study

The focus of the study is to understand pre-service teachers' possible future mathematical identities and future-oriented mathematical identity work. For that purpose, we compare and contrast one Finnish and one Slovenian case with a negative view of mathematics. Our paper was guided by the following research questions: *What is future-oriented mathematical identity work pre-service teachers with negative view of mathematics are engaged in during teacher education? What is the link between pre-service teachers' mathematical identity work and the tools used during teacher education?*

### Research persons

In 2009, the first author of this study chose a purposive sample of 19 pre-service elementary teachers as research persons for her dissertation: 6 were from the University of Lapland, Finland and 13 from the University of Maribor, Slovenia. Here, we present one case from each university: Finnish student Reija and Slovenian student Barbara. Both reported having had negative experiences with mathematics during their school years. The two cases were selected purposively by using critical case strategy (Patton, 1990): selecting a small number of cases to illuminate important information about their possible future identities. The cases

were chosen to make a point clearly and had been considered to have information rich value (Patton, 1990) and vivid expression. Thus they contribute greatly to the understanding and conceptualizing of mathematical identity work. On the basis of such cases, it is possible to develop logical generalizations in the sense of “if it happens there, it will happen anywhere” (Patton, 1990, p. 174). Further, these cases represent intense examples of identity work, but are based on the prior research literature not unusual cases.

### Data collection and analysis

Here we use narrative inquiry (see, e.g., Polkinghorne, 1995; Lieblich, Tuval-Mashiach & Zilber, 1998), which has been increasingly used to explore identity in mathematics education research (Kaasila, 2007; Black et al., 2009). The underlying premise of narrative inquiry is the belief that pre-service teachers' make sense of themselves and their world by telling stories (cf. Ricoeur, 1992). We understand mathematical identity work as storytelling; therefore we need to study this process narratively.

One hour lasting narrative interviews were conducted with Reija and Barbara in 2009. Confidentiality was assured, the purpose of the interview was explained and the relationship between interviewer and interviewees was established. Pre-service teachers' were encouraged to talk freely their life stories related to mathematics by using open-ended prompt “*Tell me about your experiences with mathematics*”. Additionally, we asked “*Tell me about your future as a mathematics teacher*”.

Then, we analyzed the data by using categorical approach or ‘analysis of narratives’, where each pre-service teacher’s story was dissected and sections belonging to a ‘future’ category were separated from the stories (Lieblich et al., 1998; Polkinghorne, 1995). The common themes or patterns were then searched in the mentioned category. The goal of such systematic comparison was to find common conceptual manifestations among the narratives (Polkinghorne, 1995).

## Results

### Reija’s and Barbara’s mathematical background

Reija summarized she “never really liked mathematics” and thought “math was boring and you have to learn so much by heart”. She strongly disliked teacher centered teaching: “We just listen to the teacher and did everything by ourselves. I didn’t really learn this way.” Reija’s motivation for learning math impaired: “I



just didn't feel like I was good at it and I wouldn't even consider learning it more. I studied as much as I had to, no more."

Barbara's experiences with mathematics were "very negative". Barbara had difficulties understanding the content: "You see that you are not good at it and someone else gets it right away and you start asking yourself 'how come I again don't understand.'" Barbara's motivation to do math was impaired: "I would find all the ways just so I wouldn't have to deal with math." Her teachers had negative attitude towards pupils: "When she saw that you didn't study, she behaved in a despicable way."

#### Present-future dialog: Anticipating future mathematics teaching

*I'm still quite afraid, but now, that I have the experience of teaching math and it's positive, I have more confidence in myself too. So I will do well also later on. Of course I have to study very hard those things I don't know. I just don't want my students to feel they hate math and the teacher is boring. Again I have much of pressure for myself to do well. I know I have to try to study harder and I will do well, because I want to be a good teacher in everything, in math too. My students deserve that I'm the best I can be. (Reija, Finland)*

In the past, Reija had a tendency to view (math) performance as highly important and had a difficult time accepting failure (Lutovac & Kaasila, 2010). Now, her clear goal of wanting to become a good math teacher in the future, despite the challenges (cf. Phelps, 2010) she has, also reflects her perfectionism. She finds a resolution in "studying hard". Reija's talk is an example of strong self-developer rhetoric (see also Kaasila et al., 2012; Lutovac & Kaasila, 2010).

It seems that characteristics of mathematics education course, such as the use of manipulative models "the teacher of the course is very into those materials" and collaborative work gave Reija more positive experiences: "We did things and we searched different kinds of information from books and did group work, so it was good for me. I like the ways we are learning; it is more student centered learning. Although Reija's emotional relationship with the subject did not change: "I still kind of don't like mathematics that much...", she is taking more of mathematics courses: "but actually, I've decided to have one more mathematics class. So that I could learn more, because I have to teach it to pupils." Reija seems to understand her weakness - low math competence and also the fact that she will have to teach mathematics eventually (cf. Phelps, 2010). Moreover, she takes initiative in trying to develop herself in order to positively influence her future teaching.

*I am sometimes afraid of mathematics. How I will teach it at all, if I don't understand? How will I be able to explain so that someone else would understand? This is what I am most afraid of now regarding the future. Just how will I explain the issue at hand, if I don't understand it myself?* (Barbara, Slovenia)

Barbara expressed many fears in her narrative; however, she does not rise beyond them to reach conclusions. Barbara continued by saying: "If I don't understand something, because I didn't learn it when I should have, I am afraid I will not be able to pass it to pupils." On the basis of this it seems as if Barbara does not see an opportunity for a resolution by working on her weaknesses.

Barbara told about her experiences in mathematics education course: "You can really see they [teacher educators] try to make us think on our own, like 'how would you teach this to pupils'. That is really great to think about!" However, despite Barbara's enthusiasm towards the course, in first future related data excerpt, she is still insecure about how she will teach, how she will explain the content to pupils (cf. Phelps, 2010). It seems that her prior experiences are dominant in her identity talk and Barbara knows what kind of teacher she will avoid becoming: "I know I will not be as my teacher that made my life miserable." But it seems that Barbara cannot offer a concrete view about what kind of teacher she would like to become. In addition, Barbara says: "I want to forget what happened." This shows that Barbara did not distance herself from her negative past, which makes it harder to have a clear vision of her positive future self.

### Comparing Reija's and Barbara's future-oriented mathematical identity work

In Reija's (Finland) identity narrative, we found clear and exact visions of the future. Reija's possible selves are also quite optimistic, and she thus expects to reach them. In her future-oriented talk, she seems to balance between expected and feared possible selves; between how she wants to be and how she does not want to be. This reflects well the idea expressed by Markus & Nurius (1986) that people imagine selves that they would like to achieve as well as those they would prefer to avoid. Furthermore, in her identity talk, the motivation is heightened, because Reija balances between her positive and negative possible selves (cf. Markus & Ruvolo, 1989).

In Barbara's (Slovenia) talk, more anxious and uncertain visions about her future as a mathematics teacher were manifested through frequent use of the utterance "I am afraid" as well as "I don't know". Too many expressions of uncertainty may signal that the pre-service teacher is struggling or weak (Urzua & Vasquez, 2008).

This can be potentially problematic, also due to a lack of clear goals in Barbara's data. She may have goals; however, the exact goals were not manifested in her future-oriented talk. In Barbara's identity talk, feared possible selves are more present than hoped-for or expected possible selves. This suggests less balance between positive and negative selves and a sense of hopelessness (cf. Markus & Ruvolo, 1989).

In both pre-service teachers' future-oriented talk, negative emotions were elicited due to an awareness of low mathematics ability and its potential hindering effect on the teaching. However, the two pre-service teachers seemed to handle this tension differently. Our findings suggest that Reija's talk seems to be more goal-directed, where possible selves are expected to come true and where balance between positive and negative possible selves is created. We see that the central element of 'decisive' identity work is finding a resolution that will promote one's professional development. Barbara's future-oriented talk is however, less goal-directed, possible selves less elaborated, and the resulting imbalance between expected or hoped-for selves and feared selves thus evoked negative emotions and uncertainty towards future teaching. Moreover, Barbara does not take further conclusions.

Possible selves have the potential to specify how pre-service teachers may change from how they are now, to what they will become (cf. Markus & Nurius, 1989). If so, based on the Finnish case, we were able to imagine what a pre-service teacher might become in the future, but the same was difficult on the basis of the Slovenian case. Due to the lack of expected possible selves, the developmental aspect seemed to be blurred; we have labeled such identity work as 'irresolute'.

## Discussion

We see the potential explanations for the differences in pre-service teachers' possible future identities and identity work, the different emphases in mathematics education courses and teacher education programs these pre-service teachers are attending. We found similarities in the contents of mathematics education courses; however Reija participated in a mathematics education course with an emphasis on developing pre-service teachers' views of mathematics, including enhancing self-confidence in mathematics. Barbara underwent mathematics education course where the emphasis is on the mathematics didactics knowledge, especially how to teach math contents. The course did not include the autobiographical aspect, such as handling pre-service teachers' prior math experiences or view of mathematics.

We see the approach to mathematics education and teacher education at the Finnish university in question as more holistic and humanistic-based, in which attention is directed towards “the person” of the teacher and a central role is reserved for pre-service teachers’ personal growth (cf. Korthagen, 2004). Additionally, interest in how pre-service teachers undergo changes as they are becoming teachers and reflective practitioners is emphasized in Finnish pre-service teacher education. For that reason, the attention paid to pre-service teachers’ narratives regarding how they view themselves as learners and teachers seems especially useful. Moreover, because highly motivated students are enrolled to the program, it makes sense that these students would exhibit self-developing tendencies.

On the other hand, in the Slovenian university in question, pre-service teachers are faced with more hours of the compulsory mathematics education courses. Further, it seems that the teacher education and mathematics education models in this case are more ‘competency-based’, emphasizing knowledge, skills, and attitudes (cf. Korthagen, 2004). The aspect of acquiring an understanding of one’s identity is thus missing. This may lead to pre-service teachers being unable to make more conscious choices, and is also related to their further development (cf. Korthagen, 2004). Therefore, pre-service teachers who feel they are unsuccessful may develop a feeling of helplessness. For that reason, the development of strong and positive teacher identity and reflection skills (Kaasila & Lauriala, 2012) are central to enhancing pre-service teachers’ views of their future as (mathematics) teachers. This however is rooted in Finnish teacher education tradition.

We see the notion of possible selves (Markus & Nurius, 1989) particularly useful in this study. Pre-service teachers’ development can therefore be seen as a process of acquiring and then achieving or resisting certain possible selves (Markus & Ruvolo, 1989). As a result, we see mathematical identity work as either closing the gap between the present and positive possible selves (e.g. expected, hoped-for, ideal selves) or increasing the gap between the present and negative possible selves (e.g. feared). In acting toward the future by continuously constructing new possible selves, pre-service teachers become active agents of their own development (Sfard & Prusak, 2005) and might engage in ‘decisive’ identity work.

Our aim is not to generalize the results to all pre-service teachers. Moreover, because the identity work was explored using pre-service teachers from only one Finnish and one Slovenian university, we are aware that the results might pertain explicitly to those two educational contexts. However, earlier Finnish studies have supported the presence of self-development talk among Finnish pre-service teachers (see e.g., Kaasila et al., 2012). We emphasize that our aim is not

to praise Finnish teacher education and criticize the Slovenian equivalent. We are well aware that the results could have been different if comparing mathematics content knowledge as the latter is emphasized more in Slovenia.

Finally, we are aware that the results of our study are context based, but they may be useful widely as they show it is possible to identify different types of pre-service teachers' mathematical identity work. Moreover, there is a connection between identity work and tools used during mathematics education and teacher education in general. These notions are useful for teacher educators in order to address to pre-service teachers' needs for promoting a successful future teaching.

We see that pre-service teachers should be assisted in balancing positive (e.g. expected, hoped-for) and negative (e.g. feared) possible selves and thus have more confidence in their future (cf. Urzua & Vasquez, 2008). One way of resisting negative possible selves and increasing the gap between present and feared possible selves is by using narrative tools, e.g. narrative rehabilitation and bibliotherapy (Lutovac & Kaasila, 2009, 2011). Pre-service teachers' feared possible selves seem to be closely related to their negative pasts as pupils; therefore, narrative tools for handling memories from school years are important for pre-service teachers' identity work (cf. Kaasila et al., 2008). In all, we see that constructing identity narratives will promote as well reflection upon the future and will enable pre-service teachers to imagine themselves as mathematics teachers in that future.

## References

- Beauchamp, C., & Thomas, L. (2009). Understanding teacher identity: an overview of issues in the literature and implications for teacher education. *Cambridge Journal of education*, 39(2), 175-189.
- Beijaard, D. (1995). Teachers' prior experiences and actual perceptions of professional identity. *Teachers and Teaching: Theory and Practice*, 1, 281-294.
- Beijaard, D., Meijer, P. C., & Verloop, N. (2004). Reconsidering research on teachers' professional identity. *Teaching and Teacher Education*, 20, 107-128.
- Black, L., Mendick, H., & Solomon, Y. (Eds.). (2009). *Mathematical relationships in education: Identities and participation*. London: Routledge.
- Di Martino, P., & Sabena, C. (2011). Elementary pre-service teachers' emotions: Shadows from the past to the future. In K. Kislenko (Ed.), *Proceedings of MAVI 16 Conference: Current State of Research on Mathematical Beliefs XVI* (pp. 89-105). Tallin, Estonia: Tallinn University of Applied Sciences.

- Dunkel, C. S., & Anthis, K. S. (2001). The role of possible selves in identity formation: A short-term longitudinal study. *Journal of Adolescence*, 24, 765–776.
- Hamman, D., Gosselin, K. Romano, J., & Bunuan, R. (2010). Using possible-selves theory to understand the identity development of new teachers. *Teaching and Teacher Education*, 26, 1349–1361.
- Hannula, M. S. (2007). Finnish research on affect in mathematics: blended theories, mixed methods and some findings. *ZDM, International Journal of Mathematics Education*, 39, 197–203.
- Kaasila, R. (2007). Mathematical biography and key rhetoric. *Educational Studies in Mathematics*, 66, 373–384.
- Kaasila, R., Hannula, M. S., Laine, A., & Pehkonen, E. (2008). Socio-emotional orientations and teacher change. *Educational Studies in Mathematics*, 67(2), 111–123.
- Kaasila, R., & Lauriala, A. (2012). How do pre-service teachers' reflective processes differ in relation to different contexts? *European Journal of Teacher Education*, 35(1), 77–88.
- Kaasila, R., Hannula, M. S., & Laine, A. (2012). "My personal relationship towards mathematics has necessarily not changed but..." Analyzing pre-service teachers' mathematical identity talk. *International Journal of Science and Mathematics Teaching*, 10(4), 975–995.
- Korthagen, F. A. J. (2004) In search of the essence of a good teacher: towards a more holistic approach in teacher education. *Teaching and Teacher Education*, 20(1), 77–97.
- Krzywacki, H., & Hannula, M. S. (2010). Tension between present and ideal state of teacher identity in the core of professional development. In C. Frade & L. Meira (Eds.), *Proceedings of the 34th Conference of the International Group for the Psychology of Mathematics Education*, (pp. 267 – 271). Belo Horizonte, Brazil: PME 34.
- Lieblich, A., Tuval-Mashiach, R., & Zilber, T. (1998). *Narrative Research. Reading, Analysis and Interpretation*. London: Sage.
- Lutovac, S., & Kaasila, R. (2009). Using narratives as innovative tools in Finnish teacher education. In S. Pavlin & A. N. Judge (Eds.), *Proceedings of the Conference "Development of Competencies in the World of Work and Education"*, (pp. 355-359). University of Ljubljana, Slovenia.
- Lutovac, S., & Kaasila, R. (2010). How to Apply the Process of Employment Using the Narrative Approach in Mathematics Education. *Didactica Slovenica*, 25(3-4), 92-109.
- Lutovac, S., & Kaasila, R. (2011). Beginning a pre-service teacher's mathematical identity work through narrative rehabilitation and bibliotherapy. *Teaching in Higher Education*, 16(2), 225-236.

- Markus, H., & Nurius, P. (1986). Possible selves. *American Psychologist*, 41, 954–969.
- Markus, H., & Ruvolo, A. (1989). Possible selves: Personalized representations of goals. In L. A. Pervin (Ed.), *Goal concepts in personality and social psychology* (pp. 211–241). Hillsdale, NJ: Erlbaum.
- Patton, M. Q. (1990). *Qualitative Evaluation and Research Methods (2nd Edition)*. Newbury Park, CA: Sage Publications.
- Pehkonen, E., & Hannula, M. S. (2004). Mathematical belief research in Finland. *Nordic Studies in Mathematics Education*, 9(2), 23–38.
- Phelps, C. M. (2010). Factors that pre-service elementary teachers perceive as affecting their motivational profiles in mathematics. *Educational studies in mathematics*, 75(3), 293–309.
- Polkinghorne, D. E. (1995). Narrative configuration in qualitative analysis. *International Journal of qualitative studies in Education*, 8(1), 12–28.
- Ricoeur, P. (1992). *Oneself as another*. Chicago: University of Chicago Press.
- Sfard, A., & Prusak, A. (2005). Telling identities: In search of an analytic tool for investigating learning as a culturally shaped activity. *Educational Researcher*, 34(4), 14–22.
- Urzua, A., & Vasquez, C. (2008). Reflection and professional identity in teachers' future-oriented discourse. *Teaching and Teacher Education*, 24, 1935–1946.
- Watson, C. (2006). Narratives of practice and the construction of identity in teaching. *Teachers and Teaching: Theory and Practice*, 12(5), 509–526.

## **(In)consistent? The mathematics teaching of a novice primary school teacher.**

HANNA PALMÈR

Hanna.Palmer@lnu.se  
Linnaeus University, Sweden

### **Abstract**

*This paper is focusing on the mathematics teaching of Helena, a Swedish novice teacher. Helena is one of seven teachers in a case study of primary school mathematics teachers' professional identity development. She is also an example of a teacher whose mathematics teaching, from an observer's perspective, may appear inconsistent with her talk about mathematics teaching. However, in this paper a conceptual framework aimed at analysing professional identity development will be used making the process of her mathematics teaching visible and then her mathematics teaching appear as consistent.*

### **Key words**

*primary school mathematics teacher, professional identity development*

### **Introduction**

There are many studies regarding novice mathematics teachers, showing how they teach, or more often how they do not teach, as intended based on their teacher training. For example, several of the studies that Cooney (2001), Phillip (2007) and Sowder (2007) refer to in their research reviews show that teacher education has little effect on teaching students, and that what students learn in teacher education tends to decline when they start working as teachers.

The conceptual framework and the empirical material presented in this paper are derived from a study of primary school mathematics teachers' professional identity development. The goal in this paper is to offer a consistent explanation to the mathematics teaching of a novice teacher, a mathematics teaching that from an observer's perspective may appear inconsistent with her talk about mathematics teaching.



According to Wilson and Cooney (2002), mathematics teachers often appear inconsistent towards their beliefs in research of mathematics teacher change. Different explanations are given to such inconsistency, for example that the investigated beliefs are not the dominant beliefs in the situation, that the individual has unconscious beliefs, that the individual for one or another reason is not acting according to her beliefs, that concepts are interpreted differently by the individual and the researcher or that the individual actually is being inconsistent to their beliefs. Another explanation is that the goal of the teacher's in the observed situation is another than learning mathematics (Skott, 2001). Similar explanations for inconsistencies have been presented also in beliefs research within other fields than mathematics education (Fives & Buehl, 2012). In this paper another approach than beliefs research will be used aiming to make the process of mathematics teaching visible and, through this, offer a consistent explanation to differences between how a novice teacher talks about mathematics teaching and her performed mathematics teaching.

First in the paper, the conceptual framework to be used will be presented. After that, the above mentioned study of primary school mathematics teachers' professional identity development will be presented briefly. This because empirical material from one of the respondents in that study, Helena, will be used in this paper. Helena is an example of a novice mathematics teacher whose mathematics teaching, from an observer's perspective, may appear inconsistent with her talk about mathematics teaching. The paper ends with a conclusion and discussion.

## Theoretical framework

A framework is, according to Eisenhart (1991), a skeletal structure designed to support or enclose something. The framework presented in this paper is aimed at enclosing the process of professional identity development as a primary mathematics school teacher and is what Eisenhart calls a conceptual framework. In the framework, two theories, communities of practice (Wenger 1998) and patterns of participation (Skott 2010 & Skott, Moeskær Larsen & Østergaard 2011) are coordinated in a conceptual framework aiming to capture both the individual and the social part of professional identity development. Communities of practice are focusing on *identity* and *identity development* while patterns of participation are focusing on teaching as the *professional* part in professional identity development. In this paper, the aim of the framework is to analyse the

process of mathematics teaching and, because of that, the whole framework will not be presented, only those parts needed for the analysis to be made<sup>1</sup>.

According to Skott (2010) and Skott et al. (2011) a teacher participates in multiple simultaneous practices in the classroom and there are patterns in the ways in which the teacher participates in these practices. The aim in patterns of participation research is to understand how a teacher's interpretations of and contributions to immediate social interactions relate to prior engagement in a range of other social practices.

*In all of this, patterns from the teacher's prior engagement in social practices are enacted and re-enacted, moulded, fused and sometimes changed beyond recognition as they confront, merge with, transform, substitute, subsume, are absorbed by, exist in parallel with and further develop those that are related to the more immediate situation (Skott, Moeskær Larsen & Østergaard 2011, p.33).*

What Skott (2010) and Skott et al. (2011) call other social practices is in the conceptual framework treated as communities of practice. A community of practice is, according to Wenger (1998), a set of relationships between people, activities and the world, a shared learning history. Communities of practice involve participation in an activity system of mutual engagement, joint enterprise and a shared repertoire. Identity formation is a dualistic process in which one half is the identification in communities of practice and the other half the negotiation of the meaning (regarding the mutual engagement, joint enterprise and shared repertoire) in communities of practice. An individual can identify and negotiate in communities of practice through engagement, imagination and/or alignment. The three ways of identifying and negotiating involve different approaches and different conditions and they do not require or exclude each other. Identification through imagination and alignment also expands membership in communities of practice regarding time and space in the physical sense.

Skott et al. (2011) focus on the immediate situation with “prior engagement in social practices (p.33)” in the background. Conversely, Wenger (1998) puts memberships in communities of practices<sup>2</sup> in the foreground while the imprint of these memberships “must be worked out in practice (p.151)”. As such, they focus on different sides of the same

<sup>1</sup> For a complete presentation of the framework: Palmer, H. (2011) Identity development in limbo: teacher transition from education to teaching. *Nordic Studies in Mathematics Education*. 15(4), 41-61

<sup>2</sup> At one time Skott et al. (2011) write “communities of practice” but they do not refer to Wenger or his definition of communities of practice.

phenomenon and when connected they offer the whole picture. At the same time as an individual participates in an immediate situation (the focus of Skott) she participates in several communities of practice (the focus of Wenger). Wenger's theory become useful when analysing an individual's different memberships in different communities of practice. Skott's theory becomes useful when analysing how such different memberships in communities of practice influences how the individual interprets and acts in immediate situations. (This is illustrated below in figure 1.) Skott et al. (2011) write that it is the responsibility of the researcher to disentangle if and how a teacher's participation in past and present practices influences the classroom. Through combining patterns of participation and communities of practice such an analysis is possible. Based on analysis of the individual's participation in forms of engagement, imagination and/or alignment, interpretations can be made about communities of practice the individual seems to negotiate and/or identify with and how these memberships influence the merged patterns of participation.

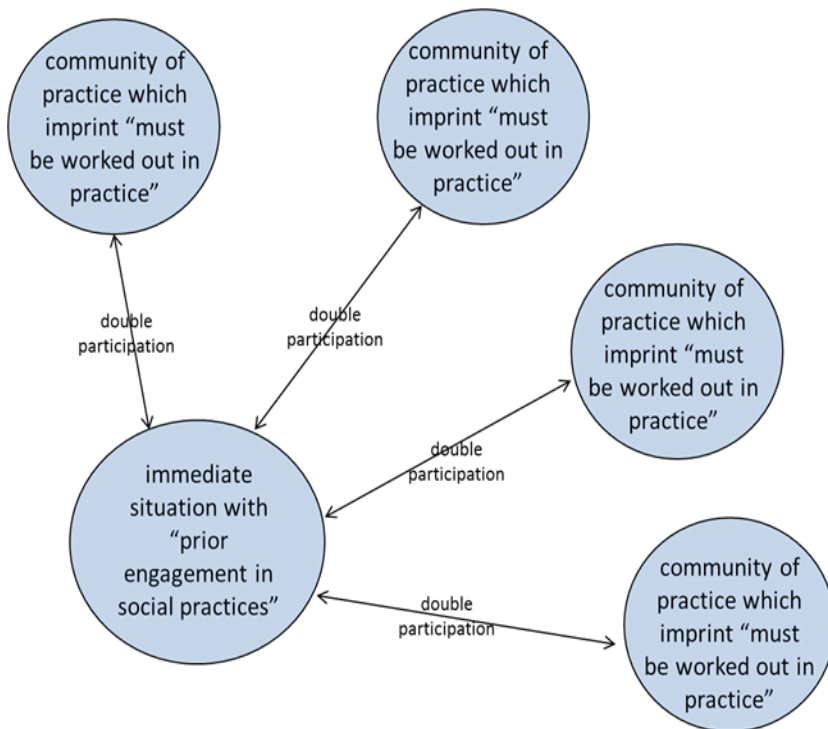

Figure 1. An illustration of the double participation in immediate situations and communities of practice.

## The study

The study of primary school mathematics teachers' professional identity development is a case study with an ethnographic approach where seven novice teachers have been followed from their graduation and two years forward. The ethnographic approach has been used to make visible the whole process of identity development, both the individual and the social part, in line with the conceptual framework above. The novice teachers in the study were selected because they chose to write their final teacher education bachelor theses on mathematics education and would, therefore, also hopefully be interested in teaching mathematics after graduation<sup>3</sup>.

The main interest in ethnography is to understand the meaning activities have for individuals and how individuals understand themselves and others (Arvatson & Ehn 2009; Aspers 2007; Hammersley & Atkinsson 2007). According to Aspers (2007), reaching such an understanding requires interaction. The empirical material in the study is from self-recordings made by the respondents, observations and interviews. All of these have been made in a selective intermittent way (Jeffrey & Troman 2004) which means that the time from the start to the end of the fieldwork has been long (two years) but with a flexible frequency. The empirical material is used as complete empiricism (Aspers 2007) implying that all of the material constitutes a whole, on which the analysis using the framework is based.

## An empirical example

Helena is one of seven primary teachers in the present study. She has been chosen for this paper as, from an observer's perspective, her mathematics teaching may appear inconsistent with how she talks about mathematics teaching. Below, there is first a description of how Helena talks about mathematics teaching at the time of her graduation. After that, her working situation during the third semester after graduation with focus on her mathematics teaching is described. Lastly, an example from one of her mathematics lessons during that semester is given. All descriptions derive from the above explained complete empiricism, that is, self-recordings made by the respondent, observations and interviews.

---

<sup>3</sup> A primary school teacher in Sweden can teach several different subjects. Sometimes two teachers work together with two classes and then they don't teach all subjects.

### Helena at the time of graduation

Helena is 41 years old when she graduates from teacher education. Before she started teacher education she had worked at preschools and schools for children with intellectual disabilities. At the time of her graduation, Helena says it will be a challenge to make as many pupils as possible experience mathematics as fun. According to Helena, good mathematics teaching is varied, laboratory-based, reality-related and problem-orientated. The good in this mathematics teaching is that it is fun and leads to students cooperating, talking and developing a desire to learn and a knowledge about how to learn mathematics. A good mathematics teacher has, in Helena's opinion, "an ability to ensure that the students really understand." The teacher ought to be able to explain the same thing in many different ways with different learning materials and adjust to the students. Helena says that she has discovered this way of teaching mathematics during her teacher education.

Less good mathematics teaching is, according to Helena, when the text book controls the teaching. Then students do not cooperate, instead, they work alone in the text book. According to Helena, this kind of mathematics teaching ends up with students having poor self-esteem and a poor knowledge of mathematics. "It does not develop any mathematics thinking." However, when she starts to work as a teacher she will lean on the text book since, as a new teacher, one cannot "cope with reforming the world." Later, when she feels secure, she will start to test new things in her mathematics teaching.

### Helena – the third semester after graduation

Directly after graduation, Helena starts work at *Aldro School*. The school is located in a small town with 150 students divided into seven classes ranging from a preschool class up to grade six. For the first spring semester, Helena worked as a substitute class teacher in grade six. After the summer break, she continued to work as a substitute class teacher but in the new grade six and she continued as the class teacher of that class the third semester after graduation. There are many problems in the class regarding students acting out and noise level. The working environment between Helena and the other teachers at the school is positive. The teachers talk about organisational stuff, e.g. who is going to supervise the schoolyard during breaks and who is going to supply-teach for sick colleagues. The teachers also talk about private stuff but seldom about teaching.

During the last semester and this third semester Helena also works with teachers from other schools in the municipality, creating common goals in science. Since

most of the teachers in the group also teach mathematics, they often discuss mathematics teaching. They talk about the importance of all children in the upper primary school being acquainted with the mathematics content of grade six. The teachers from lower secondary school in the group complain that students who have not reached the goals of grade five have to spend the whole of grade six working to accomplish them and, as a consequence, miss the mathematics contents of grade six<sup>4</sup>.

An ordinary mathematics lesson in the class starts with Helena demonstrating something on the board and then the students work in their text books. Since the students have not had enough mathematics in grade four and five they, according to Helena, are behind and need to work a lot and fast with the math books. Helena has a plan for how the students are to finish the text books before the end of the school year by dividing the chapters in relation to the number of school weeks available.

*A basic course is around ten pages and then a red or blue course is about six pages. After every second chapter there is a test. Preferably two to two and a half weeks for every chapter. It is about that. Sadly, I feel we will have to cut the problem-solving part. In the text books. I would like to work more with discussions but we will not have time for that. (Interview with Helena)*

Her motive for the time plan is to ensure that all students are confronted with all parts in the text books before the end of the school year. However, she feels “really stressed” by the tempo and says that she “would like to do this at a much slower pace” with more practical tasks and whole class discussions. When talking about the mathematics teaching she would perform if she had more time, she uses the same words as before graduation, for example fun, varied, reality-related and problem-orientated. But when planning her mathematics teaching, the setting is another.

*Not all students manage to do all tasks in time. [...] But we start on a new chapter anyhow and you simply have to skip what is left. And then we move on. [...] And you try to remind them that now there is only one more lesson. Now you have to focus during this lesson also. You need this time and we are here for you. (Interview with Helena)*

A lot of Helena’s interaction with the students during the mathematics lessons regards their behaviour and them needing to put more energy into their school

<sup>4</sup> During the time of this study there were goals and national tests in grade five and nine in Swedish schools. The pupils at Aldro School change school and teacher after grade six.

work. Helena emphasizes the students should work “neatly” in their text books and all answers are to be written in units since “it works like that in the secondary school.”

#### An example of a mathematics lesson: An introduction to statistics

The lesson to be presented in this section is when Helena is introducing a new chapter in the text book regarding statistics.

*It is not such a gigantic area, statistics. [...] They [the chapters in the text book] are usually about ten pages [...] but there are quite a lot of pictures, fairly large pictures so there are not so many tasks. [...] This chapter is not really that big. (Interview with Helena)*

The day before the introduction, Helena had asked the pupils to cut statistics out of magazines when finished with another task. However, no pupils had finished and, therefore, Helena herself has cut examples of statistics from a newspaper during the break before the lesson.

At the start of the lesson, Helena asks the students where statistics are to be found in a newspaper. None of the students raise their hand. Helena asks them again encouraging them to “think” about what statistics are needed for and why you “need to know.” One student says “the weather pages” and Helena answers approvingly that statistics are good if, for example, you want to know the amount of snow. Then she puts up the cuttings she arranged during the break, one at the time. The first shows a line chart of changes in energy prices and Helena says that it is important information for everyone who owns a house. Then a dialogue about energy prices and saving electricity starts and continues for about five minutes. The next cutting shows a bar chart of the number of people who are sick during different months of the year. The third cutting is another line chart but this time regarding mortgage interest rates and since the students don’t know what that is a new quite long dialogue follows. Then the two last cuttings are put up, one is a bar chart of crimes and the other is a sports chart. After the last cutting, Helena says that “[t]his with statistics is not just something existing in your text book but all around us. Also on the TV news.” Then she says that the students will have a little time to work in their text books.

*Now, start at page 96, think of reading the examples very carefully. What do they say? Give yourself time to understand. (Observation of Helena)*

The students start to work in their text books but after five minutes Helena interrupts them by saying that they unfortunately have to finish as the lesson is at an end. In an interview after the lesson she says it was a pity the students didn't have time to "get started working."

## Analysis

Helena's descriptions of good, and less good, mathematics teaching at the time of graduation can be understood as her having a membership in a community of practice regarding reform mathematics teaching. In this community of practice, there is a joint enterprise and a shared repertoire regarding good and less good mathematics teaching. Since the core of the community of reform mathematics teaching is located within teacher education, Helena's membership may not have been optional but mandatory for passing the exam. However, she does not express an alignment with anything; rather, she speaks of her motivations in the first person imagining her future teaching. As for engagement, Helena does not express being a part in the negotiation of the shared repertoire in the community of practice, but she has been engaged in its teaching during her teacher education.

One and a half year later, during Helena's third semester at Aldro School, four communities of practice are visible in Helena's patterns of participation: the above described community of reform mathematics teaching, a community of teachers at Aldro School, a community of teachers working with common goals in science, and a community of practice with the students in the class.

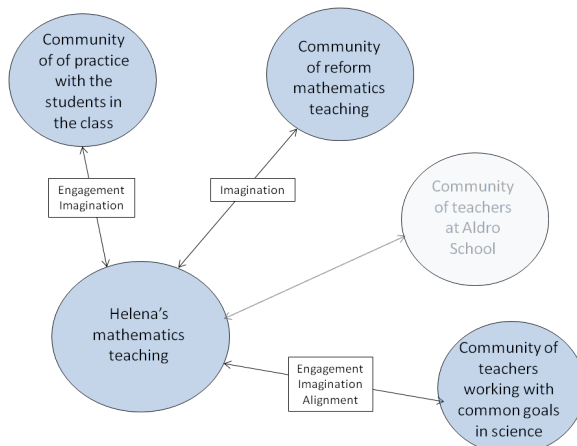

Figure 2. An illustration of communities of practice that are visible in Helena's mathematics teaching.



Most visible in Helena's mathematics teaching is the shared repertoire of the community of teachers working with common goals in science. In this community, she is a member through engagement and maybe also by alignment and imagination in a wish to receive positive feedback from the lower secondary school teachers. The central part of the shared repertoire in the community seems to be the pupils being confronted with all parts within the text book, and not the learning of those parts. Finishing the text books is central in Helena's teaching and the mathematics lessons are planned based on the number of pages in the text book and not the mathematics content.

The shared repertoire in the community of [mathematics in] the class partly overlaps with the shared repertoire of the community of teachers working with common goals in science. All students are to be confronted with all of the content in the math book. The aim of mathematics teaching in grade six seems to be to prepare the students for grade seven; not primarily regarding knowledge, but regarding study skills, writing units and reading the examples in the text book. Helena is engaged in getting the students to align with this shared repertoire. Almost all of her interactions with the students focus on this or on their behaviour.

The community of reform mathematics teaching is not very visible in Helena's mathematics lessons. Instead, the membership in this community now mainly takes the form of imagining what she would want to do if she had more time. The mathematics teaching she performs is more in line with the teaching she described as less good before graduating. Nor does the fourth community of practice, the community of teachers at Aldro School, seem to influence Helena's mathematics teaching. She is a member by engagement but the shared repertoire in this community is not [mathematics] teaching.

The lesson introducing statistics can be seen as containing elements from the community of reform mathematics teaching, the community of teachers working with common goals in science and the community of practice with the students in the class. The overall view of the area is based on the amount of pages about statistics in the text book. The text book is central in the community of teachers working with common goals in science. The cuttings from the newspaper are a way of making the teaching reality-related and Helena also says to the pupils that statistics do not only exist in their text book. Both these expressions are in line with the shared repertoire in the community of reform mathematics teaching. It is questionable if energy prices and mortgage interest rates really are the reality of twelve year olds but the cuttings engage them in long discussions. Also, discussions in mathematics are part of the shared repertoire in the community of reform mathematics teaching. However, the discussions during the statistics

lesson are not really about the mathematics content and it is dubious if statistics are made visible in the introduction. For example, the different kinds of graphs are not discussed and nor is their role in the cuttings. After all the cuttings have been put up and the pupils start to work in their text books Helena tells them to read the examples carefully and, Helena says after the lesson, it is first when the pupils work in their text books they start to “work”. As such, the lesson in statistics is an example of Helena’s merged pattern of participation regarding mathematics teaching where the community of reform mathematics teaching (reality-related, discussions), the community of teachers working with common goals in science (the basis in and the focus on “work” in the text book) and the community of [mathematics] in the class (pupils reading the examples very well, finishing the text book) are visible.

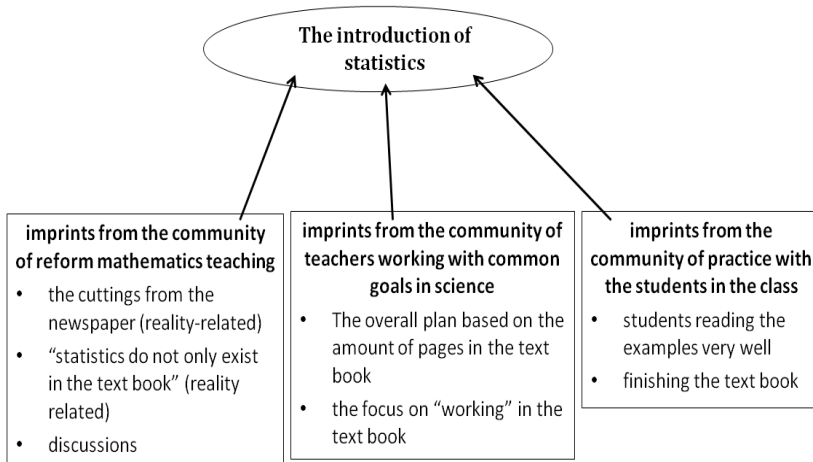

Figure 3. An illustration of imprints from communities of practice in Helena’s introduction of statistics.

## Conclusion and discussion

Before graduation Helena had a clear vision regarding good and less good mathematics teaching. When talking with Helena three semesters later she still talks about good and less good mathematics teaching using the same terms as before graduation but the way she talks is not in line with her performed mathematics teaching. Before graduation, the focus was on pupils understanding; three semesters later her mathematics teaching focuses on pupils doing. Before

graduation, the text book was associated with less good mathematics teaching; three semesters later the text book is the exclusive core of her mathematics teaching. Before graduation, Helena talked about the importance of adjusting the mathematics teaching to the pupils; three semesters later the pupils have to adjust to the plan of finishing the text books before the end of the semester. However, when analysing the process of the mutual influence between her merged patterns of participation and her memberships in different communities of practice her mathematics teaching appears as consistent.

According to Wenger (1998), identity formation is a dualistic process in which one half is the identification in communities of practice and the other half is negotiation of the meaning (negotiation about the mutual engagement, joint enterprise and shared repertoire) in those communities of practice. Identification can be made through engagement, imagination and/or alignment. Negotiation can only be made through some kind of interaction. This can be one explanation for why Helena's mathematics teaching are more visibly affected by the communities where she is a member through engagement (the community of [mathematics in] the class and the community of teachers working with common goals in science). Those memberships offer both parts of the dualistic process of identity development, identification and negotiation. Three semesters after graduation Helena is a member in the community of reform mathematics teaching by imagination and thereby she can't negotiate and half of the dualistic process of identity development is missing. Helena is also a member by engagement in the community of teachers at Aldro School but, as mentioned above, the shared repertoire in that community does not regard [mathematics] teaching.

According to Skott (2001 & 2004) teachers have multiple and sometimes conflicting teaching priorities which are brought together in every teaching situation. Decision making with conflicting motives forces teachers to prioritize. If it is not possible to integrate the visions of mathematics teaching with other broader teaching goals the teaching will not be in line with the reform. Even when believing in the reform, other demands and/or goals with the teaching can be prioritized, making the teaching look inconsistent to an observer. In the case of Helena, it seems like she prioritises the demands and/or the goals of the communities of practice where she is a member by engagement. Sadly, however, her merged patterns of participation regarding mathematics teaching really doesn't seem to focus on the learning of mathematics.

Through following Helena with an ethnographic approach and by analysing the empirical material with the conceptual framework, both the individual and the social are visible and teaching that may look inconsistent in the eyes of an

observer becomes consistent. Also, the often referred to decline of teaching students' mathematics teaching when they start working as teachers can be explained as not a decline but an onward process.

## References

- Arvastson, G., & Ehn, B. (2009). *Etnografiska observationer*. [Ethnographic observations] Lund: Studentlitteratur AB.
- Aspers, P. (2007). *Etnografiska metoder*. [Ethnographic methods] Malmö: Liber AB.
- Ball, D. L. (1990). Prospective elementary and secondary teachers' understanding of division. *Journal for Research in Mathematics Education*, 21(2), 132-144.
- Cooney, T. J. (2001). Considering the Paradoxes, Perils, and Purposes of Conceptualizing Teacher Development. In F. L. Lin & T. J. Cooney (Eds.), *Making Sense of Mathematics Teacher Education*. (pp.9-31) Dordrecht: Kluwer Academic Publishers.
- Eisenhart, M. A. (1991). Conceptual frameworks for research circa 1991: Ideas from a cultural anthropologist; Implications for mathematics education researchers. In *Proceedings of the 13th Annual Meeting of the North American Chapter of the International Group for the Psychology of Mathematics Education*, 202-219.
- Fives, H., & Buehl, M. M. (2012) Spring cleaning for the “messy” construct of teachers' beliefs: What are they? Which have been examined? What can they tell us? In K. R. Harris, S. Graham & T. Urda (Eds.), *Educational Psychology Handbook: Vol 2. Individual Differences and Cultural and Contextual Factors*. (pp.471-499) New York: American Psychological Association
- Hammersley, M., & Atkinson, P. (2007). *Ethnography. Principles in Practice*. Third edition. London and New York : Routledge
- Jeffrey, B., & Troman, G. (2004). Time for ethnography. *British Educational Research Journal* , 30(4), 535-548
- Lester, F. K. (2005). On the Theoretical, Conceptual, and Philosophical Foundations for Research in Mathematics Education. *Zentralblatt fuer Didaktik der Mathematik*, 37(6), 457-466.
- Phillip, A. R. (2007). Mathematics Teachers Beliefs and Affect. In F. K. Lester (Ed.), *Second Handbook of Research on Mathematics Teaching and Learning* (pp.157-224). Charlotte: National Council of Teachers of Mathematics & Information Age Publishing.

- Skott, J. (2001). The Emerging Practices of a Novice Teacher: The Roles of his School Mathematics Images. *Journal of Mathematics Teacher Education*, 4, 3-28.
- Skott, J. (2004). The forced Autonomy of Mathematics Teachers. *Educational Studies in Mathematics*, 55(1), 227-257.
- Skott, J. (2010). Shifting the Direction of Belief Research: From Beliefs to Patterns of Participation. In: M. F. Pinto & T. F. Kawasaki (Eds.), *Proceedings of the 34th Conference of the International group for the Psychology of Mathematics Education*. Belo Horizonte, Brazil: PME 4, 193-200
- Skott, J., Moeskær Larsen, D., & Hellsten Østergaard, C. (2011). From Beliefs to Patterns of Participation – Shifting the Research Perspective on Teachers. *Nordic Studies in Mathematics Education*. 16(1-2), 29-55.
- Sowder, J. T. (2007). The Mathematical Education and Development of Teachers. In F. K. Lester (Ed.), *Second Handbook of Research on Mathematics Teaching and Learning* (pp.157-224). Charlotte: National Council of Teachers of Mathematics & Information Age Publishing.
- Wenger, E. (1998). *Communities of Practice. Learning, Meaning and Identity*. Cambridge: Cambridge University Press.
- Wilson, S., & Cooney, T. (2002). Mathematics Teacher Change and Development. The Role of Beliefs. In G.C. Leder, E. Pehkonen & G. Törner (Eds.), *Beliefs: A Hidden Variable in Mathematics Education?* (pp.127-148) Dordrecht: Kluwer Academic Publishers.

# The association between lesson goals and task introduction in problem solving teaching in primary schooling

LIISA NÄVERI, ANU LAINE, ERKKI PEHKONEN AND MARKKU S. HANNULA

liisa.naveri@helsinki.fi  
University of Helsinki, Finland

## Abstract

*This study compares six teachers' learning goals for two problem solving lessons and their 9 to 11 year-old students' solutions to two open-ended problems. Some of the learning aims were explicitly given before the lesson and some were revealed during the lessons. The pupils worked on the first open problem in primary three and the second problem in the primary four. The problem solving lessons were video-recorded and transcribed, and pupils' solutions were collated and examined. An additional data source was the teachers' lesson plans, and the videos taken in the teachers' meeting sessions. The classification of teachers' actions was based on the teaching model developed from Polya's problem solving model (planning, introduction, guidance, feedback). This paper examines the significance of the teachers' aims of the lessons and the introduction of the two problems, with the focus on the pupils' justification of the solution for both tasks.*

## Keywords

*mathematical thinking, problem solving, primary school*

## Introduction

This article analyses the association between the teachers' introduction of an open-ended problem assignment, and the pupils' solutions to that problem. First, we review three theoretical concepts of mathematics teaching: thinking skills, problem solving and teachers' performance. We also analyze the teaching of six teachers, who participated in a project that aims to develop teaching via open-ended problems and the performance of their students. The first task was carried out in the latter part of primary three, and the second task in the middle of primary four. The analysed data consists of the teachers' lesson plans, transcriptions of the videotaped lessons, researchers' observations, the video-recorded teacher meetings, and the pupils' solutions. The aim of this study was

to find out different ways that teachers use to introduce an open problem and its associations to the reasonings found in the pupils' solutions.

### Teaching for understanding

According to the Finnish core curriculum (NBE 2004) it is not enough that pupils are able to calculate mechanically. They should also be able to make conclusions and to explain their operations both orally and in writing (NBE 2004). Hence, the teaching in primary school should aim for understanding. There are different views about what mathematical thinking is and how it could be best promoted in learning. The Finnish core curriculum (NBE 2004) states that teachers' task of teaching mathematics is to provide "opportunities for the development of mathematical thinking", and this is connected to the concept of "thinking skills". All these are characterized as high-level thinking.

According to Joutsenlahti (2005), mathematical thinking is mainly mediated by two processes: problem-solving and concept formation. In the curriculum text, there are also elements of mathematical knowledge namely: conceptual, operational and strategic (Joutsenlahti 2005, Sternberg 1996).

### Problem solving in mathematics teaching

Problem solving has generally been accepted as means of advancing thinking skills (e.g. Mouwitz 2003). The nature of problem solving has been described in the literature with the help of different problem solving models (e.g. Polya 1945, le Blanc et al. 1980, Mason et al. 1985, Schoenfeld 1985). In the following, we will rely upon the characterisation of the problem used extensively in the literature (cf. Kantowski 1980). The task is said to be a *problem*, when the solution requires that the solver uses the information already familiar to him or her in a new way.

In addition to conceptual thinking, mathematical understanding requires problem-solving skills. Learning problem-solving skills contributes to a higher level thinking (Schoenfeld 1995), and is viewed as essential for mathematical thinking and reasoning (Mason et al. 1985, Schoenfeld 1985, Stanic & Kilpatrick 1988). Polya (1945) detailed the four-stage model of problem solving in his book: understand the problem, make a plan, implement the plan, and review of the solution. Laine et al (2012) developed a teaching model founded on the Polya four-stage model: the planning phase, the task introduction, the guidance and the feedback.

Mason and colleagues' interpretation of problem solving (1982) is compatible to constructivist understanding of learning (Davis et al. 1990). One promising constructivist teaching method in mathematics seems to be the so-called "open approach" that uses open-ended problems (Becker & Shimada 1997).

### Learning argumentation

According to the Finnish curriculum (NBE 2004), the core of mathematics education in p1 and p2 is the development of mathematical thinking and reasoning. Evens and Houssart (2004) found that the ability to present general mathematical arguments begins to develop during the third and fourth years in primary school. In this respect, the curriculum seems to be implemented poorly. In Leila Pehkonen's study (2000) she states: "It was interesting to note that the quality of arguments was not so much dependent on students' age. Actually there was more variation between different teaching groups than between grades." It seems that in p2 pupils could be given those tasks in which they could explain their thinking to each other (and to the teacher). In this study, we focused on student argumentation and reasoning.

### Teachers' activities in teaching problem solving

A teacher is the most important external person in the problem-solving situation (Pehkonen 1991). Every teacher has her or his own conceptions about mathematics and its teaching and learning, and also about problem solving and its implementation. Therefore, teachers bring their own conceptions to the class, and thus they influence the decisions in their classes (cf. Pajares 1992, Calderhead 1996, Speer 2008).

According to Pehkonen and Zimmermann (1990), problem-solving can be taught through solving of different problems. However, problem-solving may also be considered as a teaching method. Actually, the tri-division described by Schroeder and Lester (1989) on teaching problem-solving helps to structure the process of problem solving. They introduced the following three aspects: teaching about problem solving, teaching for problem solving and teaching via problem solving. The first and second approaches represent the solving of problems – often separate. The third approach means that problem-solving itself acts as a teaching method. Consequently, the third approach is easily connected to the use of open-ended problems.

In this study, the aim was to find out what kind of connections there are between the teachers' aims and behaviours, with those of pupils' solutions. The



teachers' objectives for the lessons and their formulations of the respective lesson assignments are examined. The main steps of teaching are in the classification of the assignments: the aim of the lesson and the introduction of the problem. In addition the pupils' solutions are classified.

The research questions used in this study are formulated as follows:

1. What are the teachers aims for the lessons and how do the teachers introduce the problems?
2. How do the teachers develop in formulating the aim of the lessons and introducing the problem?
3. What kind of connections are there between the aims of the teachers and the pupils' solutions?

## Implementation the study

This study is part of the larger research project (Project #1135 556), which was financed by the Academy of Finland for three academic years (2010-13). The project explored the development of Finnish and Chilean teachers' teaching actions and their pupils' understanding, when they spend one lesson each month solving an open-ended problem in their classes. The present study reports on the findings of two selected tasks, whereby a wide range of implementation information was collected.

### Problems

The two problems used in this study were the aritmagon problem and the 'stick and peas' problem.

**The aritmagon problem.** Aritmagon is a triangle, on which the numbers are in the circles in the corners and their sums are in the squares on the sides of the triangle (e.g. Brown & Reid 2006).

There were four phases for the aritmagon problem; (1) to get to know the structure of the aritmagon; (2) to solve the simplified aritmagon problem containing natural numbers where two given numbers were equal (Figure 1b); (3) to find a strategy for solving aritmagons; and (4) to create an additional easy aritmagon and also a more difficult aritmagon for a peer student.

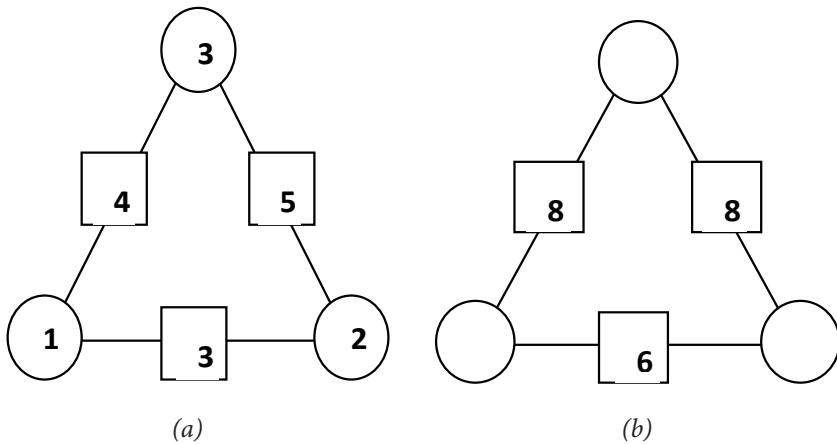

Figure 1. a) A solved aritmagon and b) an aritmagon problem.

The formulation for phase 3 was: “Aritmagons can be solved in many ways. How did you solve it? Did you find a method for solving any aritmagon, when the numbers on the sides are given and two of those are the same?”

**The ‘sticks and peas’ problem.** About one year later the same groups (the same teachers and their pupils) tackled the following open-ended problem. The problem was to construct three-dimensional objects using cocktail sticks as edges and peas as vertices. The construction of objects was limited by requiring that no more than 12 sticks could be used for one object. An example of a cube that needed 12 cocktail sticks and 8 peas was shown (Figure 2).

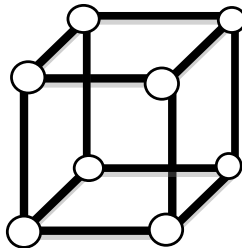

Figure 2. A cube with 12 cocktail sticks and 8 peas.

The main task was to examine the constructions made, and to explain why these were all the possibilities. Thus, essentially interest is focused to the reasoning: “How do you know that there are no other possible objects?” There was also an

additional problem for the quicker pupils to do: to construct objects using more than 12 sticks.

### The participants of the experiment

Six primary school teachers and their pupils participated in this study. All teachers had the formal Finnish teachers qualification and worked in typical municipal schools in the capital region. They had worked on open-ended problems for the research project once a month since the beginning of primary three. The second problem (stick and peas) was carried out in the middle of their fourth year, and its results were compared with the results of the first problem (aritmagon) that was solved during the latter part of the third year in primary school. We used the pseudonyms: Ada, Bea, Carla, Dana, Elionor and Fiona to preserve the anonymity of the participating teachers.

### Data collection

All teachers used one lesson (45 min) to teach each problem. Teachers' activities in class were videotaped and transcribed. All the pupils' products were collected for analysis.

In order to triangulate research results (Cohen et al. 2000), we collected pupils' solutions and other data. We received the teachers' lesson plans, about half a page each before the lesson. We observed during the problem solving lesson both the teacher and her pupils (two researchers were present in the class). One of the researchers recorded the teacher's actions on video, and the other focused on certain target pupils' behaviours. Furthermore, the project group consisting of the researchers and the participating teachers discussed the problems beforehand and afterwards. Those discussions were also recorded on video.

### Data analysis

The original video recordings were watched and transcribed. The transcripts were read several times. Two researchers classified teachers' problem-solving lessons into three categories. The reasons of the categorization were to assess how the teachers described the aim of finding a solution strategy in their lessons: (1) to solve the main problem by providing the arguments, (2) to solve the main problem and (3) to solve the more general problem.

The variables relating to the teachers and their actions – namely introduction of the problem, guidance during the solution process, introduction of the critical

feature of the problem – were classified by either two (the first problem) or one (the second problem) researchers. First, existing findings were charted, and then the researchers decided the categories for the teachers.

## Results

In this section we present the categorization of students' solutions and the teacher actions. Then we explore the relationship between these two for both of the problems. Table 1 presents the classification of the pupils' performances. Here, the basis for classification of the solutions to both tasks' is examined. All problems in the Finland–Chile project have a specific objective. The two problems analyzed in this study had the objective of developing student articulation of their strategies for solving problems. The structure of the task was the same for both problems: to become acquainted with the concepts intrinsic to the problem (1), to solve the main problem (2), to find and articulate a strategy for solving the main problem (3) and an extension problem for the quicker students (4). This article focuses on the first three components. We have analysed, what kind of solutions teachers' assignment induces in particular. Below is the classification of how the pupils explain their strategy for solving the main problem (above 3).

*Table 1. Pupils' performance categories for both tasks.*

Categories of introduction	
X	A pupil explains the strategy for solving the main problem.
Y	A pupil solves the specific main problem.
Z	A pupil solves the extension problem.

Pupils' results are reported in Tables 3 and 4 and related to the teachers' results.

Six teachers who participated in this study presented both the aritmagon problem and the 'sticks and peas' problem in their lessons.

The categorization of teachers' introduction, to search for the strategy of the main problem (3) are shown in Table 2 below.

Table 2. Categories for teachers' introduction of two problems (aritmagon and sticks and peas).

---

Categories of introduction	
A	To find the strategy for solving the problem.
B	To find an actual solution to the specific problem.
C	To find out the strategy for solving the problem in the guidance phase.

---

**The aritmagon problem.** In the aritmagon problem, category A entails the teacher introducing the aim of the task as to find the rule to solve the main problem. The main problem indicated the simplified aritmagon problem with two equal numbers. Category B requires that the teacher introduces the aim of the task to find the solution to the main problem, and to find the strategy was the actual task given to students during the guidance phase. Category C involves the teacher giving introduction to be solving the more general problem.

The following are some citations of transcripts taken during the teachers' activities at different phases. Ada guided using small steps:

*"If there are the same sums... can you find, that they will always be resolved in the same way? Think now, what you have done, in all of these, in the same way. So, you should think now, what you have done in the same way".*

Our classification for her introduction was A. Ada also emphatically guided pupils to find the strategy:

*"Where did you start?" "What have you done here?"*

*A pupil: "I made an addition."*

*Ada: "Is it enough?" ... "How could you explain it?"*

*A pupil: "It is an addition."*

*Ada: "What addition?" ... "What numbers are there?" ... "next to each other?" "How did you find these in the corners?" ... "are there the same numbers?"*

Ada guided her pupils to proceed stage by stage, until the pupils were ready to write the solution strategy. Only after that, the pupils were allowed to make and present aritmagon problems to their friends.

Bea also gave her pupils the problem to solve the simplified aritmagon problem, and to come up with the rule; therefore, Bea's approach also classified as category A.

Carla read the problem from the paper to her pupils. She set the task to think of a strategy and to make a new aritmagon problem to a peer at the same time. Because they found so much fun to make and present the aritmagon problem to a peer, the pupils moved directly to the third stage. Carla instructed the students to discover their own aritmagon problem. She did not emphasize the special case and did not return to it later. Carla had the aim to solve aritmagon problems (in general form) in her lesson plan. Thus, Carla's approach was classified to category C.

Elionor gave the problem to her pupils directly on a paper without discussing it. In the control phase, Elionor noticed that the pupils had passed the strategy point in the problem paper, but they had no time to return to it later. This approach was classified to category B.

Dana's pupils had to come up with the rule, but she did not emphasize the simplified task, but the more general case. Therefore, Dana's method was classified as category C. In the control phase, Dana asked a pupil, how she got the numbers in the lower corners.

*A pupil: "I looked over the previous task, it was the same type."*

*Dana: "Could you take advantage the previous solution?"*

*A pupil: "Well, there were two same sums, I thought that here is the same way."*

Thus, the teacher would have had a good opportunity to move from model learning to understanding learning only by asking "Why?", but she did not do so.

Fiona spent a long time (over 10 minutes) on the introduction phase. However, Fiona only mentioned that there are two same numbers in aritmagons.

*Fiona: "Have you, boys, already found solutions."*

*Boys: "Yeah."*

*Fiona: "Well, have you already discovered reasons, arguments, which always work. How do you John solve it?"*

*John: "Down 3 and 3, because the sum of  $3 + 3$  is 6."*

*Fiona: "Did you find a common thing, how easy these are to solve?"*

*John: "The same numbers."*

*Fiona: "Can you explain, if those sums are not the same? Can you get the working common aritmagon problem?"*

Therefore, Fiona's approach was classified as category B.

*Table 3. Teachers' introduction and pupils' performances for the aritmagon problem.*

		<i>Teachers and their mode of introduction</i>						Total
		<i>Ada</i>	<i>Bea</i>	<i>Elionor</i>	<i>Fiona</i>	<i>Dana</i>	<i>Carla</i>	
Solution type	X	14	0	6	0	2	0	22
	Y	1	7	2	4	8	8	30
	Z	2	1	7	9	6	0	25

In Table 3 it can be seen that if the aim of the problem was fulfilled by reasoning in the introduction phase or in the guidance phase, the results are better.

**The 'sticks and peas' problem.** The second problem was the 'sticks and peas' problem. Teachers' introduction categories are explained in Table 2. As before category A indicates that the teacher gave the problem to find out the strategy in the introduction phase: How could the pupils know that they have found all the solutions? Category B describes how the teacher gave the introduction to solve the main problem, but the strategy was asked for only in the guidance phase. Category C entails that the teacher introduces solving the task as a more general problem.

The classification for teacher introduction for the sticks and peas problem is based on lesson plans, videos, observations and teacher meetings. However, only Ada, Elionor, Bea and Dana gave beforehand written lesson plans.

Ada's introduction approach was to discover the strategy for the 'sticks and peas' problem. The pupils discussed and documented their objects systematically with the teacher. A written report of these activities was submitted to the researcher. Ada's introduction was categorized as A.

Carla's aim for the lesson was that the pupils could make as many objects as possible. When 30 minutes had passed, the pupils moved on to make larger

objects, using more sticks. Carla also said, that the pupils did not need to give names for the objects. More important for her was to get her pupils to find different kinds of objects. Carla used much of the time to allow her pupils to look for different solutions. She also guided the pupils to look at all alternatives systematically. Carla's approach was categorised as A.

Elionor's introduction was to find different objects and to identify them. Therefore, Elionor's introduction was category B. In Dana's lesson, the aim was also to mention objects by name. The classification of her approach was also B.

Fiona defined the problem as being to construct different objects. The smallest objects were named. When 13 minutes had elapsed, the students were no longer willing to make small objects. Fiona described the situation in a meeting: *"It was suddenly important for the pupils to know, how large objects still remain intact."* The classification of her approach was C.

The aim in Bea's lesson plan was to construct objects with less than 12 sticks and to name them. The pupils moved quickly to make bigger objects: *"If you have made two objects using less than 12 sticks, then you can continue by making larger objects by using more sticks."* The classification of her approach was C.

*Table 4. Teachers' assignments and pupils' performance in the 'sticks and peas' problem.*

		<i>Teachers and their mode of introduction</i>						Total
		<i>Ada</i>	<i>Carla</i>	<i>Elionor</i>	<i>Dana</i>	<i>Fiona</i>	<i>Bea</i>	
Solution type	X	18	14	0	3	0	0	35
	Y	2	0	16	4	0	0	22
	Z	0	0	4	9	19	6	38

In Table 4 it can be seen that when the aim of the problem was to use reasoning, the results were better. Dana's aim was to mention objects by name. Her way of guidance was permissive. Thus three of her pupils gave reasons in their solutions regardless of the different aim of the teacher. When the second part of the problem was given too early, pupils were not willing to remain working on the first phase, which involved making objects with small numbers of sticks (Fiona,



Bea). Moreover, when the goal was to mention the objects by name (Dana, Elionor), it appeared that the number of different alternatives remained small.

### Comparison of the results of two open-ended problems

The open-ended aritmagon problem was given in p3 (Table 3), and the open-ended construction task in p4 (Table 4). The following is a comparison of the teachers' assignments in these two open-ended problems.

*Table 5. Teachers' assignments for two open-ended problems.*

	<i>Teachers and their modes of introduction</i>					
	<i>Ada</i>	<i>Bea</i>	<i>Carla</i>	<i>Dana</i>	<i>Elionor</i>	<i>Fiona</i>
Aritmagon	A	A	C	C	B	B
'Peas and sticks'	A	C	A	B	B	C

The teachers had different aims for their lessons. Thus they guided their pupils differently, and emphasized different things. Ada's aim was to get good arguments from her students. Ada was the only teacher who introduced a general solution method to the main problem for both tasks. On the other hand, Elionor's verbal introduction was minimal in both tasks. Elionor emphasized pupil's own responsibility in their working.

Three teachers (Dana, Elionor, Fiona), had aims for both problems that were other than to find strategies to solve them. These teachers either did not emphasize the main problem, or they gave the extension task at the same time, and their pupils moved quickly forward and bypassed the reasoning phase (Fiona), repeatedly.

These results indicate that the quality of the introduction given by the teacher influences the quality of the results and performance achieved by their pupils.

## Discussion

Problem solving is important in the development of mathematical thinking (Mason et al. 1982, Schoenfeld 1985, Stanica & Kilpatrick, 1988). In the Finnish primary school curriculum, mathematical thinking comprises conceptual thinking and problem solving. Reasoning is one of the principal aims of mathematics education according to the national curriculum (NBE 2004). However, this aim does not seem to be promoted in ordinary mathematics teaching, where instead, teachers eagerly used the textbook and its tasks. Therefore, new elements should

be considered for use in instruction: tasks that foster pupils' problem solving and thinking skills. This study analyzed how such tasks are implemented by Finnish primary school teachers.

The most important entity in the learning of mathematics is the understanding. In the project, this can happen through creativity in open-ended problem solving. Through asking for arguments such tasks support the analysis of pupils' solutions and also manifest pupils' thinking. However, not all teachers implemented these ideas.

In our study, only about half of the teachers asked for pupils' arguments while solving at least one of these problems. In our project meetings we discussed the importance of reasoning. It is important that children create their own strategies for understanding mathematics. We need to understand teachers' decisions. Therefore, it is important to know what a teacher thinks about teaching and ways to help pupils and learning through their teaching mathematics. However it seems to be difficult to change established teaching approaches and therefore, all the teachers, also the elementary teachers, should understand what argumentation and reasoning means in learning.

Our study aims at understanding how teachers use open-ended problems and how that develops when they discuss their experiences and they gain more practice. Three years, once a month, in the teacher meetings we are talking about the previous task, and are planning for the next, around an open-ended problem. In these meetings, we also discuss how to teach the open-ended problem at hand. From this perspective it seems that changes in teacher behaviour are slow.

## References

- Bauersfeld, H. (1995). The structuring of the structures: Development and function of mathematizing as a social practise. In L. Steffe & J. Gale (Eds.), *Constructivism in education*. Hillsdale, NJ: Lawrence Erlbaum Associates, 137-158.
- Becker, J., & Shimada, L. (1997). *The open-ended approach*. Reston (VA): NCTM.
- Cohen, L., Manion, L., & Morrison, K. (2000). *Research Methods in Education* (5th edition). London, RoutledgeFalmer.
- Calderhead, J. (1996). Teachers: Beliefs and knowledge. In D. C. Berliner & R. C. Calfee (Eds.), *Handbook of Educational Psychology*. New York: Macmillan library. Reference: Simon & Schuster Macmillan, cop. 1996, 709-725.

- Davis, R. B., Maher, C. A., & Noddings, N. (Eds.). (1990). *Constructivist Views on the Teaching and Learning of Mathematics*. JRME Monograph Number 4. Reston (VA): NCTM.
- Evens, H., & Houssart, J. (2004). Categorizing pupils' written answers to a mathematics test question: "I know but I can't explain". *Educational Research* 46 (3), 269-282.
- Joutsenlahti, J. (2005). *Lukiolaisen tehtäväorientoituneen matemaattisen ajattelun piirteitä* [Characteristics of task-oriented mathematical thinking among students in uppersecondary school]. Acta Universitatis Tampereensis 1061. University of Tampere.
- Kantowski, M. G. (1980). Some Thoughts on Teaching for Problem Solving. In S. Krulik & R. E. Reys (Eds.), *Problem Solving in School Mathematics*, 195-203. NCTM Yearbook 1980. Reston (VA): Council.
- Laine, A., Näveri, L., Pehkonen, E., Ahtee, M., Heinilä, L., & Hannula, M.S. (2012). Third-graders' problem solving performance and teachers' actions. In T. Bergqvist (Ed.), *Proceedings of the ProMath meeting in Umeå*, 69-81. University of Umeå.
- Le Blanc, J. F., Prodfit, L., & Putt, I. J. (1980). Teaching Problem Solving in the Elementary School. In S. Krulik & R. E. Reys (Eds.), *Problem Solving in School mathematics* (pp. 104-116). NCTM Yearbook 1980. Reston, Va: NCTM.
- Mason, J., Burton, L., & Stacey, K. (1985). *Thinking Mathematically*. (the 2nd edition) Bristol: Addison-Wesley.
- Mouwitz, L. (2003). *On forms of knowledge in school mathematics-some philosophical reflections on a case study*. <http://www.vxu.se/msi/picme10/F2ML.pdf> (7.11.2005).
- Murphy, P. K., Delli, L. A. M., & Edwards, M. N. (2004). The good teacher and good teaching. Comparing the beliefs of second-grade students, preservice teachers, and inservice teachers. *The Journal of Experimental Education*, 72(2), 69-92.
- NBE (2004). *National Core Curriculum for Basic Education 2004*. National Board of Education. [http://www.oph.fi/english/publications/2009/national\\_core\\_curricula\\_for\\_basic\\_education](http://www.oph.fi/english/publications/2009/national_core_curricula_for_basic_education).
- Pajares, M. F. (1992). Teacher's Beliefs and Educational Research: Cleaning up a Messy Construct. *Review of Educational Research*, 62 (3), 307-332.
- Pehkonen, E. (1991). Developments in the understanding of problem solving. *Zentralblatt für Didaktik der Mathematik* 23/2, 46-50.
- Pehkonen, L. (2000). Written arguments in a conflicting mathematical situation. *Nordic Studies in Mathematics Education*, 2000 (1), 23-33.
- Pehkonen, E., & Zimmermann, B. (1990). *Probleemakentät matematiikan opetuksessa ja niiden yhteys opetuksen ja oppilaiden motivaation*

- kehittämiseen. Osa1: Teoreettinen tausta ja tutkimusasetelma.* [Problem fields in mathematics teaching and their connection to the development of teaching and pupils' motivation. Part 1: Theoretical background and research design.] University of Helsinki. Department of Teacher Education. Research Report 86. [in Finnish]
- Polya, G. (1945). *How to solve it? A new aspect of mathematical method.* Princeton, NJ: Princeton University Press.
- Schoenfeld A. H. (1985). *Mathematical Problem Solving.* Orlando (FL): Academic Press.
- Sierpinska, A. (1994). *Understanding in Mathematics.* London: Falmer Press.
- Speer, N. M. (2008). Connecting Beliefs and practices; A Fine-Grained Analysis of a College Mathematics Teacher's Collections of Beliefs and their Relationship to his Instructional Practices. *Cognition and Instruction*, 26 (2), 218-267.
- Schroeder, T. L., & Lester, F. K. (1989). Developing understanding in mathematics via problem solving. In P. R. Trafton (Ed.), *New directions for Elementary School Mathematics*, 1989 Yearbook of the NCTM (pp. 31-42). Reston, VA: NCTM.
- Stanic, G., & Kilpatrick, J. (1988). Historical perspectives on problem solving in the mathematics curriculum. In R. Charles & E. Silver (Eds.), *The teaching and assessing of mathematical problem solving*, pp. 1-22. Reston, VA. National Council of Teachers of Mathematics.



## Prospective teachers' conceptions of what characterize a gifted student in mathematics

LOVISA SUMPTER AND EMMA STERNEVIK

lsm@du.se

School of Education and Humanities, Dalarna University, Sweden and  
Department of Education, Uppsala University, Sweden

### Abstract

*This paper explores Swedish prospective teachers' conceptions of what characterise a gifted student in mathematics. This was studied through a qualitative questionnaire focusing on attributions. The results show that a majority of the students attribute intrinsic motivation to gifted students, more often than extrinsic motivation. Other themes were other affective factors (e.g. being industrious), cognitive factors (e.g. easy to learn), and social factors such as good behaviour and background.*

### Keywords

*attributions, conceptions, giftedness, thematic analysis*

### Introduction

The discussion on special needs education in Sweden has primarily focused on student difficulties (Mattsson, 2010). However, recently a broader focus on what gifted students might need has started (Edfeldt & Wistedt, 2009). Since there is no clear definition of what giftedness is (Mattsson, 2010) there is a need to clarify what different conceptions about gifted students exists in order to discuss the concept. Such discussion would provide a better picture of what the concept might comprise for various groups. When studying head teachers' conceptions, Mattsson's (ibid.) results show that the characteristics of such students at upper secondary level are both cognitive attributes (e.g. creative and logical ability) and non-cognitive attributes (e.g. motivation). This is in line with previous international research (e.g. Leiken & Stanger, 2011). Mattsson (2010) says that reliability of her study rests on comparisons with similar studies. This present study would allow such comparison although studying another group in the educational system. The purpose is to explore prospective teachers' conceptions about gifted students in mathematics with the following research question: Which

characteristic traits including gender are by prospective teachers attributed to gifted students in mathematics?

## Theoretical background

### Concept giftedness

Research has used different definition of giftedness depending on focus. A common starting point is to use 'special mathematical abilities' following Krutetskiis (1976). Juter and Sriraman (2011) show that depending on different emphasis on creativity, achievement, and giftedness different personalities can be portrayed and be viewed differently. Here, we start with the perspective that:

*Descriptions of giftedness are always based on the social values of the time and culture in which they are given. Throughout history, the meaning of giftedness has shifted according to the interests and preconceptions of people using the term and, like beauty, giftedness is often in the eye of the beholder (Freeman, 1979, p.7).*

This definition emphasizes that the concept is dynamic and generated by human thoughts through attributions. This is useful when studying humans' conceptions in order to find which properties are by different groups attributed to the concepts. It means that concept depends on social and cultural environment. This is similar to Mattsson's (2010) starting point. For a longer discussion about different definitions of giftedness and elements related to the concept, see e.g. Juter and Sriraman (2011) and Mattsson (2010).

### Conceptions

This study aims to investigate prospective teachers' conceptions. Thompson (1992) describes conceptions as "conscious or subconscious beliefs, concepts, meanings, rules, mental images, and preferences" (ibid, p. 132). We follow this description and conception is defined as an abstract or general idea that may have both affective and cognitive dimensions, inferred or derived from specific instances. Häggblom (2009) uses the term beliefs synonymously for opinion ('äsikt') and conception ('uppfattning'). Instead of moving in to a discussion of different affective and cognitive aspects of these concepts (see e.g. Sumpter, 2009 or Hannula, 2006), we choose to use 'conceptions' as an generic term for all these different affective concepts. This choice means that we have no intention of making any conclusions how strongly or lightly these conceptions are held.

## Attributions theory

Kelley (1973) describes attributions as part of theories used by individuals in order to get knowledge about the surrounding world. This means that attributions are part of human interpretations of phenomenon; the explanations people make for causes of events or outcomes (Weiner, 1992). Here it is interpreted as the properties that are related to the concept giftedness. These explanations include conceptions, as part of e.g. meanings, mental images and beliefs (c.f. Thompson, 1992). Through the categorisations of attributions we enable both analysis of and comparisons between categories, which provides further understanding about the chosen phenomenon. Attributions are changeable explanations in an individual's world meaning that the attributes are subjective, personal and can change over time (Weiner, 1972). Research about attributions theory can focus on contextual relationships between attributions of a phenomenon (c.f. Kelley, 1973). However, this study uses empirical data to highlight differences between categories (c.f. Weiner, 1972).

## Categories

There are different ways to create categories of attributions. Leiken and Stanger (2011) divide attributions made by three teachers into categories such as intellectual characteristics, creativity and affect/motivation/personality, where the data generated focus on the image of a gifted student and highlight personal traits. Their results do not include any attributions concerning social context e.g. background. The results depend on the definitions of gifted (i.e. what properties lies in the concept) and the methodological approach (e.g. inductive or deductive methods). The starting point in this study is that there is no initial categories in order to enable: (1) categories that have not been pre-decided; and, (2) a comparison between results of data generated categories and previous research. Data showed that there was a need to further specify the categories from the initial division of cognitive and non-cognitive factors. Non-cognitive factors are affective factors (e.g. motivation and emotion), social factors (e.g. background) and personal factors (e.g. behaviour). Here, gender is emphasised. Cognitive factors could be creativity, problem solving ability, and ability to grasp and understand.

Affective factors are a collective name involving an individual's psychological, physical and social existence incorporating both negative and positive affects (Hannula, 2006). Affective factors depend on how the social environment is organised with related conceptions about mathematics and mathematics education (Evans & Zan, 2006). For instance, affective factors such as self-esteem



in mathematics works towards good results and therefore helps to re-generates more positive affects such as liking of the subject (Zan, Brown, Evans & Hannula, 2006). One affective factor that needs further specification is motivation. We see motivation as actions derived from either intrinsic (e.g. I feel good) or extrinsic (e.g. I need to pass this exam) factors (Ryan and Deci, 2000). Emotions are defined as emotional direction: positive, neutral, or negative. According to Häggblom (2009) prospective teachers perceive that motivation (supported by positive feelings) and activeness is important, although this study does not focus on gifted students.

Social factors such as background can influence a child's education. Parents' goal for their children, including expectations, tends to increase the child's achievement (Peters, Grager-Loidl & Supplee, 2000). Another social factor is the ability to behave. Teachers at primary level do not only judge their students as gifted simply because of 'good behaviour' such as sitting down quietly and do what you are told, but it is considered a positive factor when assessing students (Hodge & Kemp, 2006). Previous research looking at teachers' attributions shows that there are differences between what is attributed to a gifted girl and a gifted boy in mathematics (Fennema, Peterson, Carpenter & Lubinski, 1990). Even though attributions such as 'independence' and 'interest for the subject' are ascribed to both genders, boys are more often considered high-achievers and attributed properties associated with advanced studies in mathematics. Boys are reported to be high achieving because of their abilities and having intrinsic motivation such as answering questions during lessons voluntarily. Boys are also considered being competitive. Girls, on the other hand, were gifted because of hard work (ibid, 1990). Sumpter (2009) studied Swedish upper secondary school teachers' conceptions about differences in boys and girls' mathematical reasoning. Most teachers said that creative mathematical founded reasoning was a neutral behaviour. It would be probable to think that such conception are related to attributions of being creative and gifted in mathematics. Therefore the concept might be more likely to be considered neutral. Here, the view is that differences between boys and girls in the prospective teachers' conceptions are not due to any biological differences, but a result of the concept 'gifted in mathematics' being gendered.

Cognitive factors include early development such as having spatial-and graphic abilities i.e. being able to do advance puzzles or to interpret difficult pictures. These factors are in relation to the age of the child (e.g. Diezmann & Watters, 2000). Logic is categorised as a cognitive factor (Mattsson, 2010). Creativity as a cognitive factor exists in contrast to a norm based standard and emerges in a social and cultural context (Csikszentmihalyi & Wolf, 2000). One way of defining

creativity in mathematics at school level is provided by Sriraman (Liljedahl and Sriraman, 2006): (1) the process that results in unusual (novel) and/or insightful solution(s) to a given problem or analogous problems; and/or, (2) the formulation of new questions and/or possibilities that allow an old problem to be regarded from a new angle. This definition allows us to categorize attributions based on that creativity is personal. Other cognitive attributions are those related to problem solving. Schoenfeld (1985) has described such competencies as resources, beliefs, heuristics, and control. These factors encompass the ability to master, identify and choose appropriate strategies.

## Method

### Method for data collection

The chosen population was students enrolled in one of the first courses of the first semester in teacher education programme in a major university in central Sweden. The students are in a mixed group including all prospective teachers from nursery to upper secondary school level. The reason for asking students in their first semester is to avoid that the attributions simply mirror a specific teacher course. The teachers of the course estimate the maximum participants to around 100 although 65 were at the random selected lessons, making this the maximum amount of respondents. Of these 65 students, 53 volunteered to answer the questionnaire. With one falling off, the final number of responses was 52 giving a response rate of 80%. The response rate is in parity with Mattsson (2010). The students answered a questionnaire at the end of a lesson. The data that constitute the base for the analysis is the written responses to the following questions: (1) How do you perceive a gifted student [in mathematics]? Describe such a student.; (2) In your description above, did you think about: (i) a boy; (ii) a girl; or, (iii) neutral?; and, (3) Which properties characterise a gifted student [in mathematics]? The purpose of first question is to give a general description of a gifted student in mathematics whereas the third question aims to further clarify by focusing on properties. By using mainly open-end questions opens up for responses not directed by the questionnaire.

### Method for analysis

In order to identify, analyse, and report patterns (themes) within the data we used thematic analysis. A theme represents a patterned responses or meaning within the data set (Braun & Clarke, 2006) and can be identified in one or two primary ways in thematic analysis, inductive or deductive. We used an inductive approach, but discussing our results using the same main categories as Mattsson

(2010): cognitive and non-cognitive factors. This means that we besides the two initial categories had a data driven analysis instead of a theory driven analysis. From these two initial categories we followed the six steps of analysis given by Braun and Clarke (2006). This includes to within the initial categories looking for similar codes and to sort these codes into different themes. When sorting we needed to look for overarching themes and relationships between themes. This included separation, e.g. looking at the differences between the attribute 'being industrious' and acting industrious such as the response 'doing your homework'. The first one is a personal property and the second one is behaviour, here set in a specific social context. In the end, the themes had to be internally coherent, consistent, and distinctive.

Another issue to take into account is the level at which themes are to be identified: semantic or explicit level, latent or interpretative level (Braun & Clarke, 2006). We conducted an analysis on an explicit level although as a second step there is an aim to go beyond description in order to reach an interpretation. The purpose of the interpretation is to theorize the significance of the patterns and their broader meanings and implication, here in relation to previous literature. This is a qualitative study trying to highlight different themes. If similar results as Mattsson (2010) this would add to a general perception of the concept 'gifted student in mathematics', since the two studies uses different methods and respondents.

## Results

The responses to the first and the third questions was gathered and analysed. The attributions made by the prospective teachers generated three themes of non-cognitive traits (motivation, other affective factors, and social factors) and one theme called cognitive traits. In the presentation below, each theme will be exemplified and compared and/or discussed with previous research.

### Non-cognitive traits

Let us start by looking at the non-cognitive traits. The main sub-categories within each of each of these three themes are listed below in Table 1.

Just as in Mattsson (2010) the most frequently found trait were attributes concerning motivation. Here, 85 % of the respondents gave a response that included motivation. The responses have been further categorised into intrinsic and extrinsic motivation. Several replies indicate conceptions describing gifted students as driven by intrinsic motivation, e.g. interested in mathematics, having

ambition and are engaged in mathematics education. Most of these attributions have a positive emotional direction. Examples of attributes that encompass extrinsic motivation were (external) goals set at a high level, high demands, (very) good tests results, (very) good grades, spending a lot of time on school work (initiated by the school context) and high pressure (originated from external causes).

*Table 1. Non-cognitive attributes. Characteristics of gifted student in mathematics as stated by the prospective teachers. The number of respondents is 52; each prospective teacher may have provided more than one character trait.*

<i>Character trait</i>	<i>Number</i>	
	<i>frequency</i>	<i>percentage</i>
<i>Motivation</i>	44	85
Intrinsic	27	52
Extrinsic	17	33
<i>Other affective factors</i>	41	79
Industrious	12	23
Social emotional traits	7	13
Active	7	13
Focused	6	12
Positive	5	10
<i>Social factors</i>	24	46
Behaviour	17	33
Background	7	13

The second category is other affective factors. The most common attribution was industrious (and here with no indication of internal or external motivation) and personal traits including social behaviour combined with emotions such as empathic, adaptability, autistic, lonely, demanding, and shy. In this theme we also find responses such as active, having patience, self-esteem, and being positive. Here we excluded all responses that are related to social behaviour, environment and background such as doing homework or academic parents. The relative large number of responses that falls into these themes mirrors research that shows that affective factors do play a role for high-achieving students if to consider high-achieving as a part of the concept 'gifted in mathematics' (Evans & Zan, 2006; Hannula, 2006; Häggblom, 2009).

Other non-cognitive traits were social factors. This is a category of attributions that differs from Mattsson (2010) and Leiken and Stanger (2011). Almost half of the prospective teachers (44%) gave a response with an attribution that falls into this theme. We divide the attributions into background (social context and general knowledge and skills), and behaviour set in a social context such as things you do (lessons and homework). The first sub-category encompasses attributions describing how students behave in the social context i.e. manners. Here we find characteristics such as working hard during class, being prepared for class, paying attention during class, raising your hand, being quiet, helpful, doing your best, doing your homework or do what you are supposed to do. This view would reinforce the view that 'good behaviour' is considered a positive factor (Hodge & Kemp, 2006). The second sub-category deals with the social context such as parents with an academic background, having had good encouragement and attributes dealing with literacy and general knowledge. These are conceptions that follow previous research saying that parents' goals for their children, including expectations, tend to increase the child's achievement (Peters, Grager-Loidl & Supplee, 2000).

### Cognitive traits

Now we focus on the attributions of cognitive traits. The main sub-categories within this theme are listed below in Table 2.

*Table 2. Cognitive attributes. Characteristics of gifted student in mathematics as stated by the prospective teachers. The number of respondents is 52; each prospective teacher may have provided more than one character trait.*

<i>Character trait</i>	<i>Number</i>	
	<i>frequency</i>	<i>percentage</i>
Easy to learn/grasp	16	31
Logical ability	10	19
Understanding	8	15
Able to apply different methods	8	15
Independence	6	12
Creativity	5	10
Problem solving	5	10

First, we can see that the sub-categories in cognitive traits are not as frequent compared to the non-cognitive sub-categories (c.f. motivation 85%). The most common reply here was easy to learn/grasp (31%). This follow previous research

studying gifted students (Diezmann & Watters, 2000; Hodge & Kemp, 2006). 'Easy to learn/grasp' implies flexibility and an ability to assimilate a mathematical content with ease and little effort. Our results differ from Mattsson (2010) who lists creative ability as the most frequently found attribution (32%). Creativity was attributed by 10% of the prospective teachers. Other cognitive characteristics were logical thinking, independence, being able to apply different methods, understanding, and problem solving. In relation to the other themes, cognitive attributions were few. The concept 'gifted student in mathematics' is here more related to affective factors than to creativity or logical ability.

## Gender

Looking at gender, none of the prospective teachers in this study gave a response to the open-end questions that included such an attribution. As a first result we conclude that gender is not a stressed category by this group of prospective teachers. In order to answer whether gifted students in mathematics is a gendered concept, the responses to the second question were gathered with the following results, see Table 3.

*Table 3. Gender of gifted student in mathematics as stated by prospective teachers. The number of respondents is 52.*

<i>Gender</i>	<i>Number</i>	
	<i>frequency</i>	<i>percentage</i>
Neutral	38	73
Girl	9	17
Boy	5	10

These results indicate that the concept was by most students stated as neutral.

## Discussion

Since there are limitations of this study, e.g. the number and selection of participants, we can talk about *indications of stereotyping* within the attributions made by the prospective teachers to the concept 'giftedness in mathematics'. The results from the analysis point out that the concept was considered a matter about non-cognitive traits more than cognitive ability. Above all positive intrinsic motivation was attributed. Compared to Mattsson (2010) similar themes were

the results of the analysis where motivation was the most common reply in both studies. Here, we can add intrinsic motivation as a sub-category. Giftedness is then more about internal factors instead of reacting to external stimuli. Another contribution, in contrast to Leiken & Stanger (2011) and Mattsson (2011), is that social factors are attributed as a part of the concept 'giftedness'. This is different than an attribute focusing on individual social skills and/or behaviour. When comparing with research not focusing specifically on mathematics we can see that social factors exist, not necessarily as a factor for giftedness but sometimes used as a part of description of interpersonal relationships (Carman, 2011). To illustrate this, one individual participating in Carman's (ibid.) study stated that a gifted person is particularly good in mathematics but not so popular socially.

Moving on to cognitive factors, the most common attribution was 'easy to learn/grasp'. This attribution was more frequent than students stressing the element of creativity, a trait commonly attached to giftedness (e.g. Mattsson, 2010; Juter and Sriraman, 2011). Creativity does not appear to be as important in prospective teachers' conceptions about giftedness in mathematics as in Juter and Sriraman's (2011) theoretical discussion of the concept.

Looking at gender, here seen as part of a social construct, the concept 'giftedness' was considered neutral. The differences between boys and girls reported by e.g. Fennema, Peterson, Carpenter and Lubinski (1990) were not repeated. However, this could be due to different countries, methods and/or targeted groups. But, it could be interesting to note that the result from this present study is in line with Sumpter's (2009) results. This could be an indication of a potential confirmation that a highly cognitive behaviour is thought of, by two different groups in the educational system, as gender-neutral phenomenon.

As summary, we see this study as (i) a contribution to research on prospective teachers conceptions; and, (ii) both confirming and adding to Mattsson's (2010) results on concept giftedness, but more research about this complex and dynamical concept is needed.

## References

- Braun V., & Clarke, V. (2006). Using thematic analysis in psychology. *Qualitative Research in Psychology*, 3, 77-101.
- Carman, C. A. (2011). Stereotypes of Giftedness in Current and Future Educators. *Journal for the Education of the Gifted*, 34(5), 790-812.
- Csikszentmihalyi, M., & Wolf, R. (2000). New conceptions and research approaches to creativity: implications of a systems perspective for

- creativity in education. In K. A. Heller (Ed.), *International handbook of giftedness and talent*. (pp.81-93) Amsterdam; Elsevier.
- Diezmann, C. M., & Watters, J. J. (2000). Identifying and supporting spatial intelligence in young children. *Contemporary Issues in Early Childhood*, 1(3), 299-313.
- Edfeldt, Å. W., & Wistedt, I. (2009). High ability education in Sweden: the Swedish model. In T. Balchin, B. Hymer & D.J. Matthews (Eds.), *The Routledge International Companion to Gifted Education* (pp. 76–83). London: Routledge.
- Evans, J., & Zan, R. (2006). Sociocultural approaches to emotions in mathematics education: initial comparisons. In J. Novotná, H. Moraová, M. Krátká, & N. Stehliková (Eds.). *Proceedings of the 30<sup>th</sup> Conference of the International Group of the Psychology of Mathematics Education*. Vol 3. Prague, Czech Republic.
- Fennema, E., Peterson, P. L., Carpenter, T. P., & Lubinski, C. A. (1990). Teachers' attribution and beliefs about girls, boys, and mathematics. *Educational Studies in Mathematics*, 21(1), 55-69.
- Freeman, J. (1979). *Gifted children: their identification and development in a social context*. Lancaster: MTP Press.
- Hannula M. S. (2006). Affect in mathematical thinking and learning. Toward integration of emotion, motivation, and cognition. In J. Maasz & W. Schloeglmann (Eds.) *Education research and practice*. (pp.209-232). Rotterdam: Sense Publishers.
- Heller, K. A., & Schofield, N. J. (2000), International trends and topics of research on giftedness and talent. In K. A. Heller (Ed.) *International handbook of giftedness and talent*, (pp.123-137) Amsterdam: Elsevier.
- Hodge, K. A., & Kemp, C. R. (2006) Recognition of Giftedness in the Early Years of School: Perspectives of Teachers, Parents, and Children. *Journal for the Education of the Gifted* 30 (2), 164-204.
- Häggbloom, L. (2009). Lärarstudenters syn på lärande i matematik. *Nordic Studies in Mathematics Education*, 14 (1), 7-38.
- Juter, K., & Sriraman, B. (2011). Does high achieving in mathematics = gifted and/or creative in mathematics? In B. Sriraman & K. Hwa Lee (Eds.), *The Elements of Creativity and Giftedness in mathematics*, (s. 45-66). Rotterdam: Sense Publishers.
- Kelley, H. H. (1973). The process of causal attribution. University of California, Los Angeles. *American Psychologist*, 107-128.
- Krutetskii, V. A. (1976). *The psychology of mathematical abilities in schoolchildren*. The University of Chicago Press.
- Leikin, R., & Stanger, O. (2011). Teachers' images of gifted students and the roles assigned to them in heterogeneous mathematics classes. In B. Sriraman &



- K. H. Lee (Eds.), *The Elements of Creativity and Giftedness in Mathematics* (pp. 103-118). Rotterdam: Sense Publishers.
- Liljedahl, P., & Sriraman, B. (2006). Musings on mathematical creativity. *For The Learning of Mathematics*, 261 (1), 17-19.
- Mattson, L. (2010). Head teachers' conception of gifted students in mathematics in Swedish upper secondary school. *Nordic Studies in Mathematics Education*, 14 (1), 3-22.
- Peters, W. A. M., Grager-Loidl, H., & Supplee, P. (2000). Underachievement in gifted children and adolescent: theory and practice. In K. A. Heller (Ed.), *International handbook of giftedness and talent*. (pp. 609-620). Amsterdam: Elsevier.
- Ryan, R. M., & Deci, E. L. (2000). Self-determination theory and the facilitation of intrinsic motivation, social development, and well-being. *American Psychologist*, 55 (1), 68-78
- Schoenfeld, A. H. (1985). *Mathematical Problem Solving*. London: Academic press inc.
- Sumpter, L. (2009). On aspects of mathematical reasoning: Affect and gender. PhD Thesis. Department of Mathematics and Mathematical Statistics, Umeå University, Sweden.
- Thompson, A. (1992). Teachers' beliefs and conceptions: a synthesis of the research. In D. Grouws (Ed.), *Handbook of Research in Mathematics Teaching and Learning* (pp.127-146). New York: Macmillan Publishing Company.
- Weiner, B. (1972) *Attribution theory, achievement motivation and the educational process*. University of California, Los Angeles *American Educational Research Association and SAGE*.
- Weiner, B. (1992). *Human motivation: Metaphors, theories, and research*. Newbury Park, CA: Sage.
- Zan R., Brown L., Evans J., & Hannula M. S. (2006) Affect in mathematics education: an introduction. *Educational Studies in Mathematics*, 63 (2), 113-121.

# Teachers' epistemic beliefs about mathematical knowledge for teaching two-digit multiplication

JANNE FAUSKANGER

janne.fauskanger@uis.no  
University of Stavanger, Norway

## Abstract

*This study explores teachers' beliefs about the knowledge they need to teach (epistemic beliefs) two-digit multiplication. In particular the study considers how teachers view novel strategies put forward by students. Teachers reflected in writing on items developed to measure mathematical knowledge for teaching (MKT). The reflections were analyzed using directed content analysis. Findings indicate that the teachers might be grouped into four according to their epistemic beliefs about MKT two-digit multiplication. Group 1 sees novel strategies as important. Group 2 emphasizes novel strategies with certain reservations. Group 3 does not regard novel strategies to be important, and finally, a fourth group who seems unwilling to emphasize novel strategies, except under certain circumstances.*

## Keywords

*teachers' epistemic beliefs, mathematical knowledge for teaching*

## Introduction

When planning and implementing professional development experiences, two issues in particular are emphasized in the literature. First, teacher educators will benefit from being familiar with teachers' MKT (e.g., Hill, Sleep, Lewis, & Ball, 2007). Second, teacher educators will benefit from being familiar with teachers' beliefs, because beliefs tend to influence teachers' approach to professional development and their eventual gains from attendance (Fives & Buehl, 2010; Goldin, Rösken, & Törner, 2009). Thus for teacher educators it is important to explore which components of MKT teachers believe are important in order to teach, i.e.—their epistemic beliefs (e.g., Fives & Buehl, 2010). Research related to teachers' beliefs about teaching knowledge in general (Fives & Buehl, 2008, 2010) and MKT in particular, is scarce, and the conceptualization of MKT has been criticized for failing to acknowledge the importance of teachers' beliefs (Petrou &

Goulding, 2011). This paper's focus on epistemic beliefs about MKT may be one minor step in the process of filling this 'gap' in the literature.

Several frameworks for teacher knowledge have been developed and these frameworks differ in important ways, such as their focus on beliefs (e.g., Petrou & Goulding, 2011). For the purpose of this paper the MKT framework is adapted (e.g., Ball, Thames, & Phelps, 2008). Researchers at the University of Michigan have developed sets of multiple choice items to measure teachers' MKT, and have used these to plan professional development tailored to teachers' needs. To meet the criticism of the format, I decided to open up the items as recommended by Schoenfeld (2007a). Follow-up questions were included to gain deeper insight into teachers' MKT as well as their beliefs about MKT. Early analyses indicate that teachers' reflections based on MKT items could bring forth aspects of their epistemic beliefs (Fauskanger, 2012). If instruction forms the basis for students' problems (e.g., Fuson, 1992), and if the nature of instruction relates to teachers' beliefs (e.g., Mason, 2010), then it can be argued that teachers' beliefs about aspects of MKT are important. The research question addressed is the following:

*What do practicing teachers' written reflections reveal about their epistemic beliefs concerning MKT two-digit multiplication?*

Written reflections on ten MKT items were collected and group discussions were conducted. The written reflections related to one item (see Figure 1) constitute the data corpus analyzed and discussed for the purpose of this paper.

## Conceptual framework

The MKT framework developed by Ball and colleagues (2008) builds on Shulman's (1986) subject matter knowledge and pedagogical content knowledge. 'Common content knowledge' (CCK)—acquired by most educated people—and 'horizon content knowledge' are two aspects of subject matter knowledge. The latter involves being cognizant of the large mathematical landscape in which the present instruction is situated. The third aspect of subject matter knowledge—'specialized content knowledge' (SCK)—is defined as "the mathematical knowledge and skill unique to teaching" (Ball et al., 2008, p. 400). Knowing whether novel strategies for two-digit multiplication work in general and justify such strategies are important aspects of SCK (see Figure 1).

Pedagogical content knowledge is divided into knowledge that combines knowledge of content and knowledge of students (KCS), knowledge that combines knowledge of content with knowledge of teaching (KCT), and

knowledge that combines knowledge of content and knowledge of curriculum. The ability to multiply two-digit numbers and get a correct answer is related to CCK. When relating two-digit multiplication to single-digit multiplication, to other arithmetical operations, to place value and to the mathematical landscape in which multiplication is involved, teachers use horizon content knowledge as well as knowledge of content and curriculum. KCS is e.g. important to be able to predict students' misconceptions, and KCT is, among other things, needed to decide how to help students correct these misconceptions.

Teachers need to be prepared to make sense of common as well as novel strategies before, during and after lessons (Even & Tirosh, 2002). Researchers suggest that instead of developing routine expertise, defined as "being able to complete school exercises quickly and accurately without understanding" (Verschaffel, Greer, & De Corte, 2007, p. 559), students should develop adaptive expertise. Hatano (2003, p. ix) defines this as "the ability to apply meaningfully learned procedures flexibly and creatively". Researchers agree that "premature teaching of standard written algorithms should be avoided" (Verschaffel et al., 2007, p. 575). There is a broad consensus among researchers that it is important for students to be actively involved in devising the algorithms for written computation.

Within the field of mathematics education, there has been a vast amount of research related to teachers' beliefs (Philipp, 2007). Teachers' beliefs about the structure, certainty and source of knowledge—often referred to as epistemological beliefs (Hofer, 2002)—are given attention because they e.g. influence teachers' pedagogical choice (Mason, 2010). Some researchers define epistemic beliefs in the same way as epistemological beliefs. For the sake of clarity, I use the term 'epistemic beliefs' with reference to teachers' beliefs about teaching knowledge (as in Fives & Buehl, 2008), and in particular teachers' beliefs about MKT two-digit multiplication. Fives and Buehl (2008) have developed a model for epistemic beliefs which includes the following categories: 1) Pedagogical knowledge—knowledge of how to teach which is unrelated to domain and content; 2) Knowledge of children, including e.g. knowledge of how children think; 3) Content knowledge, including e.g. pedagogical content knowledge; 4) Management and organizational knowledge; 5) Knowledge of self and other; and a sixth category for those teachers who seem to argue that there was nothing unique about the knowledge required for teaching.

The literature regarding MKT in general and in particular related to multi-digit arithmetic as well as literature regarding epistemic beliefs as presented above will be used to frame my analyses.

## Methodology

The research reported in this paper is part of a larger project focusing on teachers' MKT and their beliefs about MKT (e.g., Fauskanger, 2012). In the present study, 26 teachers were asked to respond to ten MKT items focusing on numbers and operations, they were also asked to reflect upon which out of the items they meant best captured MKT as important for them, and which items did not. In addition, follow-up questions were added to the items. The questions asked related to the item in Figure 1 were the following: 1) What do the students A, B and C know? 2) What, if anything, do they need to learn more about? (Please explain why); 3) Does the testlet reflect a content that is relevant for the grade(s) you teach? (Please explain why or why not and provide an illustrating example from your classroom). 4) Would you recommend your students to use some of the algorithms used by student A, B and C? (Please state the reason(s) for your answer).

3. Imagine that you are working with your class on multiplying large numbers. Among your students' papers, you notice that some have displayed their work in the following ways:

Student A	Student B	Student C
$\begin{array}{r} 35 \\ \times 25 \\ \hline 125 \\ +75 \\ \hline 875 \end{array}$	$\begin{array}{r} 35 \\ \times 25 \\ \hline 175 \\ +700 \\ \hline 875 \end{array}$	$\begin{array}{r} 35 \\ \times 25 \\ \hline 25 \\ 150 \\ 100 \\ +600 \\ \hline 875 \end{array}$

Which of these students would you judge to be using a method that could be used to multiply any two whole numbers?

	Method would work for all whole numbers	Method would NOT work for all whole numbers	I'm not sure
a) Method A	1	2	3
b) Method B	1	2	3
c) Method C	1	2	3

Figure 1. The MKT item in focus (Ball & Hill, 2008, p. 5).

The 26 teachers (8 men and 18 women) were participating in a professional development course that lasted one and one-half years. The written work reported on was given as an assignment after their first day in this course. 13 of these teachers work in grades 1 to 4, another 8 teachers work in grades 5 to 7 and 5 teachers in grades 8 to 10. Their working experience as teachers varied from less than 5 years to more than 20 years, and their formal education in mathematics/mathematics education varied from 0 to 60 ECTS<sup>1</sup> (see also table 1, second column). The focus in this paper is on these teachers' written reflections which attempt to capture how teachers articulate their epistemic beliefs about MKT two-digit multiplication.

### Analytical approach

The analysis began by identifying what was written related multi-digit problems. Having highlighted this, a two-step directed content analysis was applied (Hsieh & Shannon, 2005). First the data were divided into two themes—common and novel strategies—based on the literature regarding multi-digit arithmetic. Second, these two themes were refined into codes which went through several cycles of revision to establish consistency. The codes were based on well-established findings in the literature concerning MKT and beliefs about teaching knowledge—also presented in the previous section (see also table 2, 2<sup>nd</sup> column).

### Findings

In this section findings related to teachers' epistemic beliefs regarding MKT two-digit multiplication are presented. Due to space limitations, only a few examples from the written reflections are presented to illustrate the teachers' arguments. When asked to reflect upon which out of the items they think best captures the MKT that is important for them, two of the 26 teachers highlight the item in Figure 1. Tor writes:

*Multiplying multi-digit numbers can be challenging. From this item we see that it can be solved in many ways, and there are even more. I see that as a teacher I can teach the students different strategies for solving multi-digit multiplication problems. ... In mathematics one will benefit from understanding what is done, it is important when multiplying big numbers. It is also important to assess whether the answer is logical or not. ... When the students have done the tasks, I can figure out how they have been thinking during their work on*

---

<sup>1</sup> ECTS stands for European Credit Transfer and Accumulation System. One year of full-time studies in Norway gives 60 ECTS.

*the tasks, to confirm whether they have used a correct strategy, eventually to figure out where their thinking might be incorrect.*

Tor's writings indicate that he believes novel strategies for two-digit multiplication are important in order to: 1) understand students' thinking and whether their thinking reveals misconceptions or not (KCS), 2) decide whether or not the students' novel strategy is correct or efficient (SCK); and 3) guide and teach the students (KCT). Tor also indicates novel strategies to be important for students as more than one strategy might help them to better understand what they do. Gro first seems to agree with Tor, since she highlights the importance of knowing several strategies (novel as well as common) to be able to identify students' thinking through their written calculations and to guide them towards more efficient strategies if needed. When analyzing the answers given to the concrete questions asked (see methodology section), Tor in his writings came up with certain reservations while Gro's writings indicated that she does not value novel strategies in her teaching. It was possible to group the 26 teachers' reflections into four distinct groups (table 1 and 2, 1<sup>st</sup> column) and Tor and Gro were grouped in group 2 and 3 respectively.

#### Group 1 Novel strategies

When analyzing teachers' writings related to how to meet students using novel strategies, and to whether or not teachers would emphasize different strategies for two-digit multiplication in their teaching, five teachers say they value novel strategies. Ada, Sara and Are give a resolute yes as an answer while Inge and Laura indicate a belief that the novel strategies are to be used while working towards a commonly accepted strategy (see table 1, description group 1).

#### Group 2 Novel strategies - certain reservations

Seven teachers value the methods presented in the item, but they express some reservations (see table 1, description group 2). Oda, Lars, Klara and Mia would have used method C only. Oda suggests that the students using these methods need to learn a common strategy "... to be able to solve the problems in a more efficient and better way", but that method C could be used on the students' way towards this common strategy. She also highlights the importance of taking parents views into consideration. Jan and Harald would have used A and B and not C, or A and B in a transition stage towards common strategies. Even if Tor's writings as presented above indicate that he believes novel strategies for two-digit multiplication to be important MKT two-digit multiplication, he seems to

prefer to use novel strategies for students who struggle with a common strategy in particular.

### Group 3 "Our common strategy"

Eight teachers respond with "no" when asked if they value novel strategies (see table 1, description group 3). Mons gives the following reason: "If the students use the strategy used by student A, it places heavy demands on the students' capacity concerning mental arithmetic". Kjell emphasizes what he calls "... our common strategy". According to him there is little to gain from using methods A and B. Method C, he argues, works by accident in this particular situation. Kjell's writings indicate a belief that MKT two-digit multiplication is related to common strategies and routine expertise as opposed to adaptive expertise (Hatano, 2003). Ola and Gro seem to agree. It is interesting to note that Mons, Kjell and Ola are all teaching grades 8 to 10 and have at least 15 ECTS, but they have given wrong response to at least one of the items in Figure 1.

Gerd indicates a minor chance that she could use novel strategies while guiding her students towards common strategies. Eli writes that the students using methods A-C need to learn a standard algorithm, but gives the following reason for her claim: "... these students know multiplication well and are probably ready to learn a more efficient algorithm." She believes that the students are ready to be introduced to common strategies and might believe common written algorithms should be presented after a prolonged work with novel strategies (Verschaffel et al., 2007). Inga and Frøya justify their "no" by saying that they do not understand the algorithms themselves.

### Group 4 Common strategies - certain reservations

Six teachers write "no" when asked if they see novel strategies as important for them, but make certain reservations (see table 1, description group 4). Brit and Pia suggest that they might use method C for students who struggle, and Ragna could have used B because it is similar to the common strategy she values. Doris, Nina and Jane write that they feel uncertain; this uncertainty is related to the methods presented in the item as well as whether or not to value the methods in their teaching. Jane says "no" when it comes to using the methods in her teaching, but that students who use these methods might continue to use them. Ragna might recommend her students to use some of the methods: "it is at least possible to show them and explain."



Table 1. The four groups of teachers.

Description group	Number of teachers, which grades they teach, years of experience as teachers and their formal education. [Those who have given at least one incorrect answer]	One example from the teachers' reflections
1 - Emphasize novel strategies without reservations	5 - Ada, Sara and Laura (1 <sup>st</sup> to 4 <sup>th</sup> grade and 15 ECTS). Inge and Are (5 <sup>th</sup> to 7 <sup>th</sup> grade and no formal education). Ada, Sara and Inge have 11-20 years of experience, Laura 6-10 and Are 2-5 years.	Ada: "I think it is important for students to develop and use an algorithm that suits them."
2 - Emphasize novel strategies with certain reservations	4 [3] - Klara, Mia, and Tor (1 <sup>st</sup> to 4 <sup>th</sup> grade) and Harald (5 <sup>th</sup> to 7 <sup>th</sup> grade). The men have no formal education. Klara has 15 ECTS and Mia more than 30. Klara has been teaching for more than 21 years, Mia and Tor 11-20 years and Harald 2-5 years. [Oda (1 <sup>st</sup> to 4 <sup>th</sup> grade), Jan (5 <sup>th</sup> to 7 <sup>th</sup> grade) and Lars (8 <sup>th</sup> to 10 <sup>th</sup> grade). Oda and Lars have no formal education while Lars has 15 ECTS. All three have 10-20 years of experience as teachers].	Klara: "Yes, I would have recommended method C since it is comprehensible and is close to a common algorithm. The subdivision into ones and tens is clear and [the student seems to have] a deep understanding of the numbers values."
3 - Do not emphasize novel strategies	5 [3] - Inga, Eli and Gerd (1 <sup>st</sup> to 4 <sup>th</sup> grade) and Frøya and Gro (5 <sup>th</sup> to 7 <sup>th</sup> grade). Gerd, Gro and Frøya have no formal education. Inga and Eli have 15 ECTS. Eli has 6-10 years of experience as a teacher, Gerd more than 21 years and the other three have been teachers for 11-20 years. [Kjell, Mons and Ola (8 <sup>th</sup> to 10 <sup>th</sup> grade). Kjell and Mons have 15 ECTS and Kjell more than 30. Kjell has more than 21 years of experience as a teacher, Mons, 2-5 years and Ola 6-10 years].	Frøya: "I would rather present the method I recognize and feel comfortable with, or the method I think is the simplest which in this case is method A. The reason why I would choose this method is the wish to present for the students a method I feel safe about."
4 - Prefer not to emphasize novel strategies, except under certain circumstances	2 [4] - Pia (1 <sup>st</sup> to 4 <sup>th</sup> grade) and Brit (5 <sup>th</sup> to 7 <sup>th</sup> grade). Both have 15 ECTS. Pia's experience as a teacher is 11-20 years and Brit has been a teacher for more than 21 years. [Jane, and Ragna (1 <sup>st</sup> to 4 <sup>th</sup> grade), Doris (5 <sup>th</sup> to 7 <sup>th</sup> grade) and Nina (8 <sup>th</sup> to 10 <sup>th</sup> grade). Nina has no formal education. The other three 15 ECTS. Jane and Doris have more than 21 years of experience, while Ragna and Nina have been teaching 11-20 years].	Pia: "I would rather not recommend these [methods]. But, if students struggle to understand the common algorithm I would have shown them the method used by student C."

In summary, the epistemic beliefs of these 26 teachers as revealed in the written reflections can be categorized into groups as presented in table 1. First, some teachers indicate that novel strategies are important both for themselves and their students. Second, some other teachers favor novel strategies with certain reservations. An example is teachers emphasizing one or two novel strategies, but not necessarily the ones present in Figure 1. A third group of teachers do not regard novel strategies as important for their students or themselves. Finally, some teachers would rather not emphasize novel strategies, but might under certain circumstances.

## Discussion

The 26 participating teachers can be placed in four groups according to their epistemic beliefs concerning MKT two-digit multiplication as revealed in their written reflections (see table 1). The first group of teachers—emphasizing novel strategies without reservations—consists of five teachers. These five teachers suggest that novel strategies are important MKT two-digit multiplication—and thus value both CCK and SCK (see table 2, 1<sup>st</sup> row). In particular—for these teachers—novel strategies are important to be able to understand and guide students (KCS and KCT). These teachers' epistemic beliefs—highlighting knowledge of children's thinking as well as content knowledge (Fives & Buehl, 2008)—indicate that they are able (and willing) to make sense of students' novel strategies (Even & Tirosh, 2002). They seem to be willing to involve students in devising algorithms for two-digit multiplication (Verschaffel et al., 2007), and developing students' adaptive expertise (Hatano, 2003) seems to be important for them.

The seven teachers in the second group (see table 1)—though they make certain reservations—seem to believe that to be able to guide students (KCT) they need to know some novel strategies themselves (SCK), but not necessarily the ones presented in this MKT item (see table 2, 2<sup>nd</sup> row). These teachers' epistemic beliefs relate to content knowledge and to (a lesser extent to) children's thinking (Fives & Buehl, 2008) and indicate that they will be less prepared to make sense of students' novel strategies (Even & Tirosh, 2002) than the first group of teachers. They seem to be willing to involve students in devising algorithms for two-digit multiplication (Verschaffel et al., 2007)—but only a few algorithms, and preferably in the transition towards a standard algorithm. Developing students' adaptive expertise (Hatano, 2003) seems to be less important than the learning of a common strategy.

Table 2. Teachers' epistemic beliefs about MKT two-digit multiplication.

Description group	<p>What the groups of teachers believe to be important related to</p> <ol style="list-style-type: none"> <li>1. Aspects of epistemic beliefs about teaching knowledge (Fives &amp; Buehl, 2008, 2010)</li> <li>2. Aspects of MKT (e.g., Ball et al., 2008)</li> <li>3. MKT multi-digit multiplication (Even &amp; Tirosh, 2002; Hatano, 2003; Verschaffel et al., 2007)</li> </ol>
1 - Emphasize novel strategies without reservations	<ol style="list-style-type: none"> <li>1. Children's thinking (2) and content knowledge (3)</li> <li>2. CCK, SCK, KCS and KCT</li> <li>3. Make sense of students' novel strategies, be willing to involve students in devising algorithms and develop students' adaptive expertise</li> </ol>
2 - Emphasize novel strategies with certain reservations	<ol style="list-style-type: none"> <li>1. Content knowledge (3) and to a lesser extent children's thinking (2)</li> <li>2. CCK, SCK (to some extent), KCS and KCT</li> <li>3. Make sense of (some) students' novel strategies, be willing to involve students in devising (a few) algorithms and develop students' adaptive expertise (to some extent)</li> </ol>
3 - Do not emphasize novel strategies	<ol style="list-style-type: none"> <li>1. Content knowledge (3) and to a lesser extent children's thinking (2)</li> <li>2. CCK, SCK (one teacher only), KCS and KCT (one teacher only)</li> <li>3. Common strategies and routine expertise, be willing to involve students in devising algorithms (one teacher only)</li> </ol>
4 - Prefer not to emphasize novel strategies, except under certain circumstances	<ol style="list-style-type: none"> <li>1. Content knowledge (3)</li> <li>2. CCK, SCK (to some extent)</li> <li>3. Common strategies and routine expertise</li> </ol>

For the third group of teachers (see table 1), their epistemic beliefs relate to content knowledge—and to a lesser extent to students' thinking (Fives & Buehl, 2008). All (except Eli's) written reflections indicate that common strategies are most important MKT two-digit multiplication (CCK), but Eli's writings suggest common strategies to be built from novel strategies. Because of this, knowing

novel strategies (SCK) will be important for teachers in order to guide students towards common strategies (KCS, KCT) (see table 2, 3<sup>rd</sup> row).

The teachers in the fourth group (see table 1) seem to prefer common strategies, but (some of) these novel strategies might be part of their MKT two-digit multiplication—e.g. if some students struggle. These teachers' epistemic beliefs relates to content knowledge (Fives & Buehl, 2008). Their writings indicate that they to a smaller extent than the other groups of teachers will be prepared to make sense of students' novel strategies (Even & Tirosh, 2002), and they do not seem to value students' thinking (Fives & Buehl, 2008). They also seem to be less willing to involve students in devising algorithms for two-digit multiplication (Verschaffel et al., 2007). Developing students' adaptive expertise (Hatano, 2003) seems to be unimportant (see table 2, bottom row).

This study does not indicate that the teachers' formal education and years of experience influence their epistemic beliefs about MKT two-digit multiplication. As an example, teachers with no formal education in mathematics/mathematics education are spread among all four groups (see table 1, 2<sup>nd</sup> column). When it comes to grade level, the first group—emphasizing novel strategies without reservations—does not include any teachers teaching 8<sup>th</sup> to 10<sup>th</sup> grade, but with only five teachers teaching this grade level included in the study, no conclusions can be drawn.

## Conclusion

The purpose of this research was to study what practicing teachers' written reflections reveal about their epistemic beliefs regarding MKT two-digit multiplication. For the purpose of this paper teachers' reflections related to one MKT item focusing on MKT two-digit multiplication (Figure 1) have been analyzed.

As a group, the teachers emphasizing novel strategies with little (Group 2) or no reservations (Group 1) seem to be most in line with the research in the field, e.g. developing students' adaptive expertise (Hatano, 2003) and being prepared to make sense of novel strategies (Even & Tirosh, 2002). Further, it seems like most of the teachers who would use novel strategies in their teaching, but who make some reservations, share (some of) the following beliefs that (some of the) novel strategies: 1) are better suited for mental rather than written arithmetic; 2) are time-consuming and delay the calculations; 3) anticipate too much mental arithmetical knowledge and 4) are more difficult for students (than common strategies) which in turn makes it easy to make mistakes. In addition, some

teachers use parents' wish for common strategies as an argument against novel strategies, and some (directly or indirectly) present their own knowledge related to novel strategies as an impediment. The reservations made by these teachers overlap with the reservations made by the teachers who do not value novel strategies (Group 3) for two-digit multiplication to a certain extent. There are, however, important differences among the groups of teachers when it comes to involvement of students (and their thinking) in devising algorithms, and to develop the students' adaptive expertise.

The teachers' epistemic beliefs relate to children's thinking as well as to content knowledge (Fives & Buehl, 2008). Using MKT as an analytic lens in addition to Fives and Buehl's (2008) categories provides teacher educators with the possibility of a more fine-grained discussion. As an example, all groups of teachers seem to value content knowledge, but it seems like those who do not value novel strategies regard CCK as most important while those who value novel strategies also include SCK as an important part of their content knowledge. It is important for teacher educators to identify the MKT that is valued by teachers because this makes it possible to address issues related to that knowledge in professional development.

At least three limitations need to be acknowledged for the current study. First, the number of participants is relatively low. Second, only reflections related to one item are analyzed, and the choice of item and questions asked might have influenced the findings. Third, directed (or theory driven) content analysis is applied. The main strength of this approach is that existing theory can be supported and extended, but theory driven analysis has some inherent limitations in that you "approach the data with an informed but, nonetheless, strong bias" (Hsieh & Shannon, 2005, p. 1283). As a result, one might only find evidence that is supportive of a theory and overemphasis on a theory can make researchers blind to other contextual aspects. A directed approach, however, makes explicit the reality that researchers are unlikely to be working from the naive perspective that is often viewed as the hallmark of data driven analysis/conventional content analysis (Hsieh & Shannon, 2005). When it comes to research related to epistemic beliefs about MKT, little previous research exists, nonetheless it is important—as a starting point—to build on what is already there.

The findings from this study can be seen as demonstrating the existence of phenomena worthy of further investigation or "existence proof" in the sense described by Schoenfeld (2007b, p. 88). The findings indicate that further work related to teachers' epistemic beliefs about aspects of MKT is important. The findings also indicate that teachers' written reflections as a fruitful methodological

approach for studying teachers' epistemic beliefs about MKT might be further investigated.

## References

- Ball, D. L., & Hill, H. C. (2008). *Mathematical knowledge for teaching (MKT) measures. Mathematics released items 2008*. [http://sitemaker.umich.edu/lmt/files/LMT\\_sample\\_items.pdf](http://sitemaker.umich.edu/lmt/files/LMT_sample_items.pdf)
- Ball, D. L., Thames, M. H., & Phelps, G. (2008). Content knowledge for teaching: What makes it special? *Journal of Teacher Education*, 59(5), 389-407.
- Even, R., & Tirosh, D. (2002). Teacher knowledge and understanding of students' mathematical learning. In L. English (Ed.), *Handbook of international research in mathematics education* (pp. 219-240). Mahwah, NJ: Erlbaum.
- Fauskanger, J. (2012). *Teachers' epistemic beliefs about HCK*. Paper presented at the The 12th International Congress on Mathematics Education (ICME 12), COEX, Seoul, Korea.
- Fives, H., & Buehl, M. M. (2008). What do teachers believe? Developing a framework for examining beliefs about teachers' knowledge and ability. *Contemporary Educational Psychology*, 33(2), 134-176.
- Fives, H., & Buehl, M. M. (2010). Teachers' articulation of beliefs about teaching knowledge: conceptualizing a belief framework. In L. D. Bendixen & F. C. Feucht (Eds.), *Personal epistemology in the classroom* (pp. 470-515). New York, NY: Cambridge University Press.
- Fuson, K. C. (1992). Research on whole number addition and subtraction. In D. A. Grouws (Ed.), *Handbook of research on mathematics teaching and learning* (pp. 243-275). New York, NY: MacMillan.
- Goldin, G., Rösken, B., & Törner, G. (2009). Beliefs - no longer a hidden variable in mathematical teaching and learning processes. In J. Maass. & W. Schlöglmann (Eds.), *Beliefs and Attitudes in Mathematics Education* (pp. 1-18). Rotterdam, The Netherlands: Sense Publishers.
- Hatano, G. (2003). Foreword. In A. J. Baroody & A. Dowker (Eds.), *The development of arithmetic concepts and skills* (pp. xi-xiv). Mahwah, NJ: Erlbaum.
- Hill, H. C., Sleep, L., Lewis, J. M., & Ball, D. L. (2007). Assessing teachers' mathematical knowledge. What knowledge matters and what evidence counts? In F. Lester (Ed.), *Second Handbook of Research on Mathematics Teaching and Learning* (pp. 111-156). Charlotte, NC: Information Age Publishing.
- Hofer, B. K. (2002). Personal epistemology as a psychological and educational construct: An introduction. In B. K. Hofer & P. R. Pintrich (Eds.), *Personal*

- epistemology: The psychology of beliefs about knowledge and knowing* (pp. 3-14). Mahwah, NJ: Lawrence Erlbaum Associates Publishers.
- Hsieh, H.-F., & Shannon, S. E. (2005). Three approaches to qualitative content analysis. *Qualitative Health Research, 15*(9), 1277-1288.
- Mason, L. (2010). Beliefs about knowledge and revision of knowledge: on the importance of epistemic beliefs for intentional conceptual change in elementary and middle school students. In L. D. Bendixen & F. C. Feucht (Eds.), *Personal epistemology in the classroom* (pp. 258-291). New York, NY: Cambridge University Press.
- Petrou, M., & Goulding, M. (2011). Conceptualizing teachers' mathematical knowledge in teaching. In T. Rowland & K. Ruthven (Eds.), *Mathematical knowledge in teaching* (pp. 9-25). London: Springer.
- Philipp, R. A. (2007). Mathematics teachers' beliefs and affect. In F. K. Lester (Ed.), *Second Handbook of Research on Mathematics Teaching and Learning* (pp. 257-315). Charlotte, NC: Information Age Publishing.
- Schoenfeld, A. H. (2007a). Commentary: The complexities of assessing teacher knowledge. *Measurement: Interdisciplinary Research and Perspectives, 5*(2), 198-204.
- Schoenfeld, A. H. (2007b). Method. In F. K. Lester (Ed.), *Second Handbook of Research on Mathematics Teaching and Learning* (pp. 69-107). Charlotte, NC: Information Age Publishing.
- Shulman, L. S. (1986). Those who understand: Knowledge growth in teaching. *Educational Researcher, 15*(2), 4-14.
- Verschaffel, L., Greer, B., & De Corte, E. (2007). Whole number concepts and operations. In F. K. Lester (Ed.), *Second Handbook of Research on Mathematics Teaching and Learning* (pp. 557-628). Charlotte, NC: Information Age Publishing.

**SECONDARY TEACHERS' VIEWS OF  
MATHEMATICS AND ITS TEACHING**





# **Affective pathways and visualization processes in mathematical learning within a computer environment**

INÉS M<sup>a</sup> GÓMEZ-CHACÓN

igomezchacon@mat.ucm.es  
Complutense University of Madrid, Spain

## **Abstract**

*This article reports on a qualitative study of 30 prospective secondary school mathematics teachers; it was designed to investigate and acquire insight into the affect associated with the visualization of geometric loci using GeoGebra. It aimed and determining how the use of dynamic geometry applications impacted students' affective pathways; the approach adopted was to consider affect as a representational system. The results provide: (1) insights into teacher students' affect linked to motivation through their beliefs, goals and self-concept; and (2) the recognition that the use of imagery in computer problem-solving is influenced by basic instrumental knowledge.*

## **Keywords**

*affect, visual thinking, teacher training, geometry, GeoGebra.*

## **Introduction**

Problem-solving expertise is assumed to evolve multi-dimensionally (mathematically, metacognitively, affectively) (Schoenfeld, 1992) and involve the holistic co-development of content, problem-solving strategies, higher-order thinking and affect, all in varying degrees. This expertise must, however, be set in a specific context. Future research should therefore address the question of how prospective teachers' expertise can be holistically developed (Leder, Pehkonen and Töner, 2002).

Integrating technology into Math lessons is a complex issue. Hence, prospective teachers clearly require new technological and didactic skills (e. g. Monaghan (2004)). Accordingly, a serious review of the current strategies for preservice (and in-service) training of teachers in this recent complex domain is called for.

The research described here was conducted with a group of 30 Spanish mathematics undergraduates (prospective secondary school mathematics teachers). The main aim of this essay is to explain that in an environment in dynamic geometry, visualization is related to the viewer's affective state. The construction and use of imagery of any kind in mathematical problem-solving constitute a research challenge because of the difficulty of identifying these processes in the individual. The visual imagery used in mathematics is often personal in nature, related not only to conceptual knowledge and belief systems, but laden with affect (Goldin, 2000; Gómez-Chacón, 2000b; Presmeg and Banderas, 2001).

Regarding the conjunction of visual thinking and affective states, the expert's contributions underline some important results of research in this field. On one hand, the lack of agreement on preference for visualization and mathematical ability (Eisenberg, 1994, Presmeg and Bergsten, 1995). On the other hand, studies of visualization in the technological environment show the tools that are efficient in helping the students to maintain productive affective pathways for problem solving (e.g. McCulloch, 2011).

In the technological environment, different studies consider that computerized learning environments open an avenue to realizing the potential of visual approaches and experimentation for mathematics' meaningful learning. Not denying this claim, in which we also believe, we would like to indicate that in our own research, discrepancies and inconsistencies were found between cognitive and affective routes taken by students and between attitudes towards mathematics. As regards visual thinking there were not only productive affective pathways but also difficulties with visualization displaying more variety in the pathways (Gómez-Chacón, 2011). The data showed a lack of visual comprehension and processes linked to the visual perception, a lack of ability to connect a diagram with its symbolic representation, or differences between emotions, attitudes and beliefs about visualization in exposed problem solving and in action (Gómez-Chacón and Joglar, 2010).

This article focuses on the relationship between technology and visual reasoning in problem-solving, seeking to build an understanding of the affect (emotions, values and beliefs) associated with visualization processes in geometric loci using GeoGebra. The question posed is: What are the factors that helped the students to stay on-or get back onto- an enabling pathway of affect instead of sliding down to anxiety, fear and despair?

## Theoretical considerations

Different theoretical approaches to the analysis of visualization and representation have been adopted in mathematics education research. In this study the analysis of the psychological (cognitive and affective) processes involved in working with (internal and external) representations when reasoning and solving problems requires a holistic definition of the term visualization. Arcavi's proposal has consequently been adopted:

*“the ability, the process and the product of creation, interpretation, use of and reflection upon pictures, images, diagrams, in our minds, on paper or with technological tools, with the purpose of depicting and communicating information, thinking about and developing previously unknown ideas and advancing understandings” (Arcavi, 2003: 217).*

Analysis of those two complementary elements -- image typology and use of visualization -- was conducted as per Presmeg (2006) and Guzmán (2002). In Presmeg's approach, images are described both as functional distinctions between types of imagery and as products (concrete imagery, kinesthetic imagery, dynamic imagery, memory images of formulae, pattern imagery). In Guzman they are categorized from the standpoint of conceptualization, the use of visualization as a reference and its role in mathematization, and the heuristic function of images in problem-solving (isomorphic visualization, homeomorphic visualization, analogical visualization and diagrammatic visualization). This final category was the basis adopted in this paper for addressing the handling of tools in problem-solving and research and the precise distinction between the iconic and heuristic function of images (Duval, 1999) to analyze students' performance.

The reference framework used to study affective processes has been described by a number of authors (Goldin, 2000; Gómez-Chacón, 2000a and 2011), who suggest that local affect and meta-affect (affect about affect) are also intricately involved in mathematical thinking. Goldin (2000: 211) contends that affect has a representational function and that the affective pathway exchanges information with cognitive systems. According to Goldin, the potential for affective pathways is at least in part intrinsic to individuals. Both these claims were substantiated by the present data. For these reasons, while social and cultural conditions are discussed, the focus is on the individual and on any local or global affect evinced in mathematical problem-solving in the classroom or by the interviewees. This aspect of students' problem-solving was researched in terms of the model used in prior studies (Goldin, 2000: 213; Gómez-Chacón, 2000b: 109-130; Presmeg and Banderas-Cañas, 2001: 292), but adapted to technological environments.

## Research methodology

In this paper, the work presented draws on selected developed teaching experiment about Geometric Locus using GeoGebra which belongs to a larger project. This study is based on a design experiment (e.g. Cobb et al. 2003). The qualitative research methodology used consisted of observation during participation in student training and output analysis sessions as well as semi-structured interviews (video-recording). The procedure used in data collection was student problem-solving, along with two questionnaires: one on beliefs and emotions about visual reasoning and the other on the interaction between cognition and affect technology (the former was filled in at the beginning of the study and the latter after each problem was solved). In the intervention, six non-routine geometric locus problems were posed, to be solved using GeoGebra during the training session. For the description of the problems, the solution outline and its design features, see (Gómez-Chacón and Escribano, 2011). In this paper we will comment on some results concerning Problem 1 and 5.

*Problem 1: “Find the equation of the locus formed by the barycenter of a triangle ABC, where  $A = (0, 4)$ ,  $B = (4, 0)$  and C is a point in the circle  $x^2 + y^2 + 4x = 0$ ”.*

This is basic problem. The statement of the problem determines the steps of the construction of geometric locus. Using the locus tool, GeoGebra produces a precise representation of the locus. The student can only check the locus visually. To obtain an algebraic answer, it is necessary to take 3 points on the locus and then forming the circle by passing through the 3 points. We now obtain an algebraic equation.

*Problem 5: “Find the point  $P = (x, y)$  such that distance  $(P, A) = (5 / 3) * \text{distance } (P, B)$ ”.*

Just by writing the equations and, completing the square, we obtain the equation of a circle. The level of this problem is advanced in regards to the geometric locus. The problem is easily solved using paper and a pencil. The difficulty lies in expressing “distance” in GeoGebra.

Geometric locus training was conducted in three two-hour sessions. In the first two sessions, the students were required to solve the problems individually in accordance with a proposed problem-solving procedure that included the steps involved, an explanation of the difficulties that might arise, and a comparison of paper-and-pencil and computer approaches to solving the problems. Students

were also asked to describe and record their emotions, feelings and mental blocks when solving problems. The third session was devoted to common approaches and the difficulties arising during the process of solving the problems. A preliminary analysis of the results from the preceding sessions was available during this session.

*Table 1. Student questionnaire on the interaction between cognition and affect.*

---

*Please answer the following questions after solving the problem:*

---

1. Was this problem easy or difficult? Why?
2. What did you find most difficult?
3. Do you usually use drawings when you solve problems? When?
4. Were you able to visualize the problem without a drawing?
5. Describe your emotional reactions, your feelings, and specify whether you got stuck when doing the problem with a pencil and paper or with a computer.
6. If you had to describe the pathway of your emotional reactions when solving the problem, which of these routes describes you best? If you do not identify with either, please describe your own pathway.

Affective pathway 1 (enabling problem-solving): curiosity → puzzlement → bewilderment → encouragement → pleasure → elation → satisfaction → global structures of affect (specific representational schemata, general self-concept structures, values and beliefs).

Affective pathway 2 (constraining or hindering problem-solving): curiosity → puzzlement → bewilderment → frustration → anxiety → fear/despair → global structures of affect (general self-concept structures, hate or rejection of mathematics and technology-aided mathematics).

7. Now specify whether any of the aforementioned emotions were related to problem visualization or representation and the exact part of the problem concerned.
- 

The problem-solving results required a more thorough study of the subjects' cognitive and instrumental understanding of geometric loci. This was achieved with semi-structured interviews conducted with nine group volunteers. The interviews were divided into two parts: task-based questions about the problems, asking respondents to explain their methodologies and a series of questions

designed to elicit emotions, visual and analytical reasoning, and visualization and instrumental difficulties.

A model questionnaire proposed by Di Martino and Zan (2003) was adapted for this study to identify subjects' belief systems regarding visualization and computers to study their global affect and determine whether the same belief can elicit different emotions from different individuals.

A second questionnaire, drawn up specifically for the present study, was completed at the end of each problem. The main questions are shown in Table 1.

The protocols and interviewee data were analyzed for their relationship to affect as a representational system and the aspects are described in Section two. This research has an exploratory, descriptive and interpretative character. Data analysis is mainly inductive, as categories and interpretation are built from the obtained information.

## The findings

The findings (for this paper) can be categorized under two headings:

1. Beliefs about visual reasoning and emotion typologies of the group.
2. Typology of cognitive-affective pathways generated.

### Beliefs about visual reasoning and emotion typologies

The data showed that all students -30 prospective teachers- believed that visual thinking is essential to solving mathematical problems. However, different emotions were associated with this belief. Initially, these emotions toward the subject were: like (77%), dislike (10%), indifference (13%). The reasons given to justify these emotions were: a) pleasure in knowing that expertise can be attained (30% of the students); b) pleasure when progress is made in the schematization process and an elegant conceptual form is constructed (35%); c) pleasure and enjoyment afforded by the generating of in-depth learning and the control over that process (40%); d) pleasure and enjoyment associated with the entertaining and intuitive aspects of mathematical knowledge (20%); e) indifference about visualization (13%); f) displeasure when visualization is more cognitively demanding (10%).

A similar response was received when the beliefs explored related to the use of dynamic geometry software as an aid to understanding and visualizing the

geometric locus idea. All the students claimed to find it useful and 80% expressed positive emotions based on software's reliability, speedy execution and potential to develop their intuition and spatial vision. They added that the tool helped them surmount mental blocks and enhanced their confidence and motivation. As future teachers, they stressed that GeoGebra could not only support visual thinking, but also help maintain a productive affective pathway. They indicated that working with the tool induced positive beliefs towards mathematics itself and their own capacity and willingness to engage in mathematics learning (their self-concept as mathematics learners).

### Typology of cognitive-affective pathways generated

To answer the research question the typology of cognitive-affective pathways of the group was analyzed. Here we illustrate this with two cases. As noted in the preceding paragraph, the belief that visual thinking is essential to problem-solving and that dynamic geometry systems constitute a visualization aid, particularly in geometric locus studies, was widely extended across the study group. This particular belief enabled students to maintain a positive self-concept as mathematics learners in a technological context and to follow positive affective pathways with respect to each problem, despite their negative feelings at certain stages along the way and their initial lack of interest in and motivation for engaging in computer-aided mathematics.

To illustrate the above statement, we describe Nani's and Marta's case. In Table 2 we summarize students' characteristics. The top row items were the criteria for choice of the individual cases.

Table 2. Characteristics of student's case.

<i>Student</i>	<i>Mathematical achievement</i>	<i>Visual cognitive style</i>	<i>Beliefs about computer learning</i>	<i>Feelings about computers</i>	<i>Beliefs about visual thinking</i>	<i>Feelings about visualization</i>
Nani	Average	Non-visualizing student	Positive	Dislikes	Positive	Dislikes
Marta	Low	Style not clear	Positive	Dislikes	Positive	Like



### Nani's Case

Nani is a non-visualizing thinker with positive beliefs about the importance of visual reasoning. However, she claimed that her preference for visualization depends on the problem and that she normally found visualization difficult. It was easier for her to visualize “real life” than more theoretical problems. Her motivation and emotional reactions to the use of computers were not positive, although she claimed to have discovered the advantages of GeoGebra and found its environment friendly. She also found that working with GeoGebra afforded greater assurance than manual problem-solving because the solution is dynamically visible.

Convincing trainees such as Nani that mathematical learning is important to teaching their future high school students, helps them keep a positive self-concept, even if they don't always feel confident in problem-solving situations (Table 3).

Let us have a look at the solution to Problem 5 for this student. She illustrates well the meaning of what we have called the positive pathway: despite negative feelings, it keeps the student in a positive mathematical self-concept structure in the global affect area for the whole learning experience. We recall the question for Problem 5 (to see section 3). Using GeoGebra the solution is simple, but it may be necessary for the students to have more advanced knowledge and a more advanced coordination and flexibility between registers. To consider different distances (and to avoid problems with the locus tool), as experts, we use an auxiliary segment CD, a point E on the segment and the distance  $r$  between C and E. Now, we construct a circle with a center in A and radius  $r$ , and another circle with its center in B and radius  $(5/3)*r$ . The intersection of both circles generates two points in the locus. With the locus tool, we obtain a circle. The key point is to consider the “variable distances”, and to control it with a segment, and not, for example, with a slider. This can be difficult for some students.

Nani has made this by using pencil and paper. She wrote down the equations but she did not know how to draw them using GeoGebra even though she tries it with sliders which gives her a visual idea of the answer. This student uses an invalid instrumental element. She uses the “slider” tool to displace the “mover point”. The student realizes that the “mover point” must be controlled, and the control is done by the slider. The problem is that, for GeoGebra, the slider is a scalar so it can't be used with the locus tool (we used GeoGebra version 3.07). She explains:

"I have drawn points A and B and a slider  $r$ . The greatest circle  $c$  would depend on this  $r$ . The other circle has a center in B and radius  $3 \cdot r / 5$  so that the obtained ratio would be  $5/3$ . We calculate the intersection of both circles C and D and we join these points with A and B. We can use the "distance" command to see that the required proportion of distances was indeed satisfied. To see which figures are formed, we make the trail to C and D and we move the slider. This is the result" (Fig. 1):

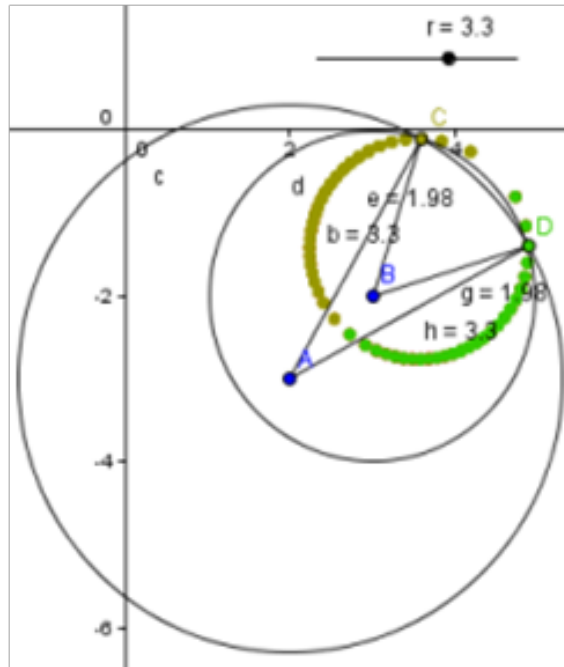

Figure 1. Nani's solution problem 5.

The affective pathway that she indicates is showed in Table 3. Nani points out that her difficulties have been in "understanding the sentence and the information about the circles to obtain the ratio of  $5/3$  for the points. Without a doubt, for me, it seemed to be the most difficult of the six problems. First, I did not understand well the sentence and then, I did not know how to solve it. As a matter of fact, I needed to ask for help because I did not know how to do it. I felt frustrated at the start when I could not see a possible way of solving the problem and I also felt desperate because I did not know how to deal with the problem. I was puzzled when I saw the answer. The overall feelings for this problem were negative".

Table 3. Summary of Nani's cognitive-affective pathways reported in questionnaire problems solving about Problem 5.

		<i>Cognitive-emotional processes</i>				
<i>Affective pathway</i>	Curiosity	Frustration	Expectation	Desperation	Puzzlement	Satisfaction
<i>Cognitive process</i>	Reading, understanding of the problem Imagery concrete pictorial	Not seeing that solution process had to continue	Physical manipulation- Kinetics Mathematical object	Not instrumental management	Upon seeing that shown strategy was leading to the answer Interactive image generation	Upon obtaining the answer Interactive image Analogic Visualization

However, the longitudinal study of this student allowed us to see that even though she does not have a great preference for computer use, the importance of mathematics and using the computer to achieve concrete objectives and the overall objective of the subject's structure allows her to stay in the productive affective pathways. In the interaction phase between affect and cognition, a clear relationship between objectives, purposes and beliefs appeared (Cobb, 1986). In her own words, she said:

*"I think that the computer, not only the GeoGebra program, is a very good complementary aid for all those who are studying mathematics. Nowadays, they are two closely linked concepts. That is, there is nobody who studies mathematics and does not use the computer at any point...mathematics is more linked to the computer and, specifically, to programs like GeoGebra (for example, if teaching high school mathematics is desired)".*

An analysis of the relationship between this student's different affective pathways in the solving of several problems and her cognitive visualization shows that the visualization - negative feelings interactions stem essentially from the student's lack of familiarity with the tools and want of resources in her search for computer-transferable analogical images and her switch from a paper and pencil to a computer environment in her interpretation of the mathematical object.

### Marta's Case

She is a student whose visual thinking style is not clearly identified during the study. Marta shows a belief on the importance of positive visual reasoning (“because visual reasoning helps in having a better understanding of the problem and consequently, its solution”). This affirms that she likes to use visualizations and representations because it makes the understanding of the problem easier and she considers it “an entertaining way of dealing with the problem even though it also requires formalization later”. She said that when she does mathematics with technological software, she feels insecure even though the specific use of GeoGebra helps her. In her own words, “I do not like and I cannot end up liking it. I feel a little nervous and insecure, not because of GeoGebra but because computers intimidate me since I am not able to completely understand them. However, when I managed to represent it with GeoGebra, the result made me more satisfied than when I solve it, for example, with paper and pencil”.

Let us consider Marta's case and Problem 1 (item 3) to illustrate the inconsistency that is produced between her emotions and what the student considers she achieved with interactive visualization. The student shows a great satisfaction from the problem and demonstrates an affective pathway of type 1 (Table 4).

*Table 4. Marta's reported affective pathway.*

---

*Affective pathway 1 (enabling for problem solving):*

*curiosity → puzzlement → bewilderment → encouragement → pleasure → elation → satisfaction → positive global structures of affect.*

---

But in this problem, the student uses GeoGebra as an advanced blackboard, but she does not use dynamic properties. The student has a priori image and she uses GeoGebra to confirm the idea. She repeats the constructions for a number of points to build the solution her wants. To draw the geometric locus, she uses the tool “conic by 5 points”. The students' failure was not necessarily due to a lack of understanding of elementary geometry. Instead, it reflected the goals they established and the transfer between two different contexts: paper and pencil and computer in which she interpreted the mathematical object. Hence, the example gives an illustration that behaviors that might initially be dismissed as irrational begin to make sense when the contexts in which subjects were operated and the goals they attempted to achieve are considered. The behavior of this student

demonstrates the need to pay attention to teacher training to the instrumental deconstruction of the tool locus.

Marta, as well as Nani, when she was asked about the importance of mathematics and technology-assisted learning in view of their specific goals as subjects, and within its overall goal structure as an individual, said: “For me mathematics is essential to both the individual and their training, not only for success in everyday life, but in order to acquire other skills and sentiments that are not achieved in other ways. We have seen this happening with the program Geogebra, through which we could solve problems that were impossible to solve in any different manner. So, in this case, the computer is essential, and in many other cases it promotes learning in a high-school student”. Also, she indicated that as a future teacher, although she felt somewhat insecure with computers, she would certainly use the computer for teaching maths: “from my point of view, presenting objects in mobility helps to make connections between concepts and others around. Also, the fact of being able to make a graphical representation builds understanding in the students and it can get to resemble a real-life problem even though at first glance it did not seem like that”.

It appears that for these prospective teachers when technology tools are involved, their beliefs about learning computer and visual reasoning with DGS impacts their affective pathways during problem solving and sometimes even their decisions regarding whether or not use the tool at all.

## Discussion and conclusion

The results of this study suggest that various factors are present in conjunction with visual thinking. The first appears to be the study group’s belief that visual thinking and their goal to become teachers would be furthered by working with computer technology. The data shows that all the student teachers believed that visual thinking is essential to solving mathematical problems. That finding runs counter to other studies on visualization and mathematical ability, which reported a reluctance to visualize (e.g., Eisenberg, 1994). However, different emotions were associated with this belief. There is a social discourse which holds that DGE could help with problem solving; it is reported that this belief, because it is held by the social group, has been of significant impact for individuals’ beliefs. Also, there is a belief in using computers that software is a tool that contributes to overcoming negative feelings; this belief has an impact on motivated behavior and enhances a positive self-concept as a mathematics learner. The internalization of these social beliefs determined their behaviour, choices and had more influence than self-efficacy beliefs on their technical and mathematical knowledge regarding

the specifics of the task. Such beliefs had a strong impact both in achieving their academic goals in respect to learning with the computer and in the persistence and effort they invested to get the desired success.

The cognitive–affective states in the visual problem-solving processes with Geometric Locus problems using GeoGebra appeared as a tendency in the study group. Focusing on local affect, the data indicated matches among subjects in positive feelings of curiosity in the initial stage of problem solving. This is the stage when students try to look for an image of the problem that permits them to capture its structure, and then develop feelings of satisfaction and happiness when they achieve the construction of the interactive image. However, feelings of disorder, confusion, a mental block, and frustration appear during the generating of interactive images and the use of analogic visualization. It became apparent with these examples, that having a tool available, as GeoGebra, is not enough to get a good visualization. If the particular software capability, that the prospective teacher wishes to employ, has not been developed as an instrument in respect to the concepts at hand, it is useless and can even have adverse emotional reactions on one's affective pathway.

## Acknowledgments

This work has been supported by grants of Complutense University of Madrid Research Vice-Presidency Projects PIMCD-UCM-200-2009; and PIMCD-UCM-115-2010 and Research project ACEIA (Computer Algebra and Artificial Intelligence) of UCM. Ref. 910563.

## References

- Arcavi, A. (2003). The role of visual representations in the learning of mathematics. *Educational Studies in Mathematics*, 52(3), 215–24.
- Cobb, P. (1986). Contexts, Goals, Beliefs, and learning Mathematics. *For the Learning of Mathematics*, 6 (2), 2-9.
- Cobb, P., Cofrey, J., di Sessa, A., Lehrer, R., & Schauble, L. (2003). *Design experiments in educational research*. *Educational Researcher*, 32(1): 9-13.
- Di Martino, P., & Zan, R. (2003). What does 'positive' attitude really mean? In *Proceedings of the 27th Conference of the International Group for the Psychology of Mathematics Education* (Vol. 4, pp. 451–458). Honolulu, Hawaii.
- Duval, R. (1999). Representation, vision and visualization: Cognitive functions in mathematical thinking, Basic issues for learning. In F. Hitt & M. Santos (Eds.), *Proceedings of the 21st North American PME Conference*, 1, 3–26.

- Eisenberg, T. (1994). On understanding the reluctance to visualize. *Zentralblatt für Didaktik der Mathematik*, 26, 109–113.
- Goldin, G. A. (2000). Affective pathways and representation in mathematical problem solving. *Mathematical thinking and learning*, 2 (3), 209–219.
- Gómez-Chacón, I. M<sup>a</sup>. (2011). Mathematics attitudes in computerized environments. A proposal using GeoGebra. In L. Bu and R. Schoen (Eds.), *Model-Centered Learning: Pathways to Mathematical Understanding Using GeoGebra*, (147-170). Rotterdam: Sense Publishers.
- Gómez-Chacón, I. M<sup>a</sup>, & Escribano, J. (2011). Teaching geometric locus using GeoGebra. An experience with pre-service teachers. *GeoGebra International Journal of Romania (GGIJRO)*, *GeoGebra The New Language For The Third Millennium*, 2(1), 209-224.
- Gómez-Chacón, I. M<sup>a</sup>, & Joglar, N. (2010). Developing competencies to teach exponential and logarithmic functions using GeoGebra from a holistic approach. *Educação Matemática Pesquisa*, São Paulo, v.12(3), 485-513.
- Gómez-Chacón, I. M<sup>a</sup>. (2000a). *Matemática emocional. Los afectos en el aprendizaje matemático. (Emotional Mathematics. Affects in Mathematics Learning)*. Madrid: Narcea.
- Gómez-Chacón, I. M<sup>a</sup>. (2000b). Affective influences in the knowledge of mathematics. *Educational Studies in Mathematics*, 43: 149-168.
- Guzmán, M. de (2002). The role of visualization in the teaching and learning of mathematical Analysis. In *Proceedings of the 2nd International Conference on the Teaching of Mathematics (at the undergraduate level)*. University of Crete. Greece.
- Leder, G., Pehkonen, E., & Töner, G. (2002). *Beliefs: A hidden variable in mathematics Education?* Dordrecht: Kluwer Academic Publishers.
- Monaghan, J. (2004). Teachers' Activities in Technology-based Mathematics Lessons. *International Journal of Computers for Mathematical Learning*, 9(3), 327-357.
- McCulloch, A. W. (2011). Affect and graphing calculator use. *Journal of Mathematical Behavior*, 30, 166–179.
- Presmeg, N. C., & Balderas-Cañas, P. E. (2001). Visualization and affect in nonroutine problem solving. *Mathematical thinking and learning*, 3 (4), 289-313.
- Presmeg, N. C. (2006). Research on visualization in learning and teaching mathematics. In *Handbook of Research on the Psychology of Mathematics Education: Past, Present and Future. PME 1976-2006*. Ed. Sense Publishers, 205–235.
- Schoenfeld, A. H. (1992). Learning to think mathematically: Problem solving, metacognition, and sense making in mathematics. In D. A. Grows (Ed.),

*Handbook of research on mathematics teaching and learning* (pp. 334-370). New York: Macmillan.





## Preservice mathematics teachers' metaphors for mathematics, teaching, and the teacher's role

PÄIVI PORTAANKORVA-KOIVISTO

paivi.portaankorva-koivisto@helsinki.fi  
University of Helsinki, Teacher Education Department

### Abstract

*This study used metaphors as a tool to gain insight about preservice mathematics teachers' views of mathematics, teaching, and the teacher's role. Data for this study was gathered by 16 student teachers who wrote three metaphors: "mathematics is ..." at the beginning of their pedagogical studies before mathematics methods courses, "teaching is ..." after the first practical classroom experiences, and "as a mathematics teacher I am ..." after their pedagogical studies. The results of this study indicated that prospective mathematics teachers' metaphors for mathematics were mostly categorized in "mathematics as a language" category, their metaphors for teaching in "overwhelming" category, and their metaphors for the teacher's role in "self-referential" category. One explanation for this might be in the students' life situations. Before their pedagogical studies they have studied mathematics as their major or minor for 2-3 years, and their very first experiences from school and acting as a teacher were thrilling.*

### Keywords

*metaphor for mathematics, metaphor for teaching, metaphor for the teacher's role*

### Introduction

Teacher's beliefs about mathematics, its learning and teaching are reflected strongly in his practice. Reflection is assumed to play a key role in change of practice. Many researchers see a cyclical relationship between changing beliefs and changing practices. (Kagan, 1992; Lerman, 2002; Wilson & Cooney, 2002.) A number of recent studies have focused on elementary teachers' beliefs (c.f. Hannula & al. 2005, 2006; Allen, 2010). Still primary teachers' views of mathematics can differ from prospective mathematics teachers' views. Primary teachers very often consider mathematics as difficult, repugnant or even frightening (Pietilä, 2002). It is therefore important to study how mathematics

student teachers describe their views of mathematics. One way to explore these views is with the help of metaphors.

## About metaphors

The word metaphor in its Greek root is based on *metapherein*, meaning to transfer or carry. That means that something is carrying across, and thus by metaphor we denote that something is, in some sense, something that it literally is not. As metaphors focus on similarities, they can be used to express views of the nature of mathematics. While they provide a way of talking about current views of mathematics, metaphors can open up new ideas of thinking about these perceptions. (Sterenberg, 2008; Lakoff & Núñez, 2000.)

Metaphors are not mere words or expressions instead they are ontological mappings across conceptual domains. A metaphor is not just a matter of language, but of thought and reason. They involve understanding one domain of experience in terms of a different domain of experience. (Lakoff, 1993.) Therefore metaphors can allow students to understand and express abstract matters in concrete ways (Sam, 1999). Noyes (2006) points out that metaphors can reveal some hidden beliefs of mathematics and help teacher educators to create conflict situations that might shift the meanings of mathematics. Reeder & al. (2009) believe that if experiences in teacher education programmes are to bring about meaningful transformation for pre-service teachers, teacher educators must provide opportunities for students also to critically examine their own thinking and beliefs about teaching and learning.

## Metaphors for mathematics

Mathematics as a *journey* is one of the common themes that are likely to come up in various studies (Sam, 1999; Noyes, 2006; Schinck & al., 2008). Mathematics can be “a challenging journey and you get rewarded by arrival at your destination” or “learning mathematics is like an easy stroll” or “running uphill”. Journeys include “places and timings, obstacles and short cuts, dead ends and all too often, going around in circles”. These metaphors are most often expressing experiences or the process of learning mathematics.

Mathematics as a *skill* is closely linked to a utilitarian view of mathematics (Sam, 1999). Noyes (2006) uses the word *toolkit* and describes it as a bag of rules, methods and conventions that we can use to model, interpret or change the world around us. Schinck & al. (2008) propose that 38% of the metaphors contained

codes referring to mathematics as a *tool*. That category included metaphors like “duct tape, instruction manual, and a pencil”.

The third category in Sam's (1999) study was mathematics as a *game* or a *puzzle*. This category is closely related to the problem solving views and in those metaphors mathematics was viewed as something to be solved. It reflected the fact that learning mathematics is fun and challenging. Schinck & al. (2008) use a category *structure* and included metaphors like “mathematics as a game” in that category. In Schinck's & al's (2008) study it was the second most prevalent theme and structure codes were found in 82% of the metaphors. The theme was divided into two sub-themes; an interconnected structure (44%) and a hierarchical structure (41%). Their argument was that in metaphors like “a jigsaw puzzle” or “Rubik's cube” mathematics was viewed as many separate pieces that are connected together by the student, and in metaphors like “a video game” and “a castle of cards” mathematics is understood “one level at a time and that skipping levels would expose the student to danger”. Noyes (2006) also uses a category called structure, but his reasoning is based on mathematical ontology.

Both Sterenberg (2008) and Noyes (2006) also found a category called “*mathematics as a language*”. It encouraged a consideration of the humanistic dimensions of mathematics, and “maths is all around us” was seen as a feature of the self-existent quality of mathematics.

## Metaphors for teaching

There are two categories for metaphors for teaching, as can be seen in Sfard (1998). *Acquisition* metaphors describe teaching as delivering the knowledge to be acquired. In the *participation* metaphor the teacher is seen as a co-participant and preserver of discourse. Reeder & al. (2009) uses three categories and their combinations, namely production, journey and growth. These go well with Ernest's (1989) views of the teacher's role and intended outcome: (1) the teacher is an instructor and outcome is skills and correct performance, (2) the teacher is an explainer and outcome is conceptual understanding with unified knowledge, or (3) the teacher is a facilitator and outcome is confident problem posing and solving.

Metaphors categorized as *production* were most common in the Reeder's & al's (2009) data and indicated that students passively receive knowledge from teachers. For example, “the teacher is as a sponge full of knowledge, squeezing it out into the empty glass”. In Cassel's and Vincent's (2011) study most of the mathematics students' responses (64%) were placed in the category of *end-product*. This

category consisted descriptive words such as complicated, challenging, outcome, right ingredients, get answers, and laying a foundation. For example “teaching math is like building a house with bricks because it takes a lot of patience and many different components to make it whole”. Also in Martínez & al’s (2001) study the majority of experienced teachers as well as prospective teachers shared traditional metaphors depicting teaching and learning as *transmission of knowledge*.

Metaphors categorized as *a journey* described the teacher as a guide or leader of an adventure with the students actively participating in the journey. Some metaphors also indicated that the teacher continually learns with her students as things are discovered. (Reeder & al., 2009.) Cassel and Vincent (2011) called this category *process* and 23% of science students in their study were in this category. Some examples of their descriptive words were interaction, change, discover, exploring, and interesting; “teaching science is like watching a flower grow”. Martínez & al. (2001) described this category as *constructivist* and only a small group of teachers in their study were expressing constructivist metaphors.

The third category of metaphors was metaphors for teaching as *growth*. These metaphors depicted the teacher as one who gives something to the students that they need but the students can use it in their own way. The teacher is more like a nurturer working with students, and the students are curious life-long learners. (Reeder & al., 2009.) A minority seemed to conceive teaching and learning as a *social process*, the name given by Martínez & al. (2001) for this category.

In Cassel’s and Vincent’s (2011) study the third category was different. The students (20%) described teaching of mathematics or science with words as dark, intimidating, does not make sense, a lot of work, no understanding, and scary. These metaphors were labelled in the category called *overwhelming*. “Teaching math is like teaching another language because students may not understand a single word.”

## Metaphors for the teacher’s role

Metaphors for teacher’s role can be categorized according to Manual for the NorBa Project (Löfström, Poom-Valickis & Hannula, 2011) which is based on Beijaard’s & al’s (2000) tripartition of teachers as subject matter experts, didactical experts, and pedagogical experts. Löfström & al. (2011) developed the model further and included two additional categories: self-referential and contextual metaphors. *Subject matter experts* possess vast and detailed knowledge and they transmit information to their students. *Didactics Experts* know how to chop the content

into comprehensible parts and facilitate students' learning. *Pedagogical experts* focus on caring and nurturing students' holistic development. *Self-referential metaphors* indicate the characteristics of the teacher's personality. They tell us who the teacher is. *Contextual metaphors* on the other hand describe where or in what kind of setting or environment the teacher works.

## Method

Data for this study were gathered from 16 mathematics teacher students in three parts. The first part of the data was metaphors for mathematics, and these were collected at the beginning of the semester before the students started their pedagogical studies and their mathematics methods courses. The second part of the data was metaphors for teaching, and these were collected in the middle of the studies after teacher students' first practical classroom experiences. The third part of the data dealt with metaphors for teacher's role. These metaphors were collected after the semester at the end of teacher students' pedagogical studies.

The assignment was: the students were asked to expand the statement "mathematics is ..."/ "teaching is ..."/ "as a mathematics teacher I am ...", and to continue with explanations for their statements. They were also asked to identify themselves in their texts so that the answers could be put together later on. Only the metaphors with students' permission to use as data were gathered for this study.

The analysis was made in two phases: first a short description of categories was developed for metaphors "mathematics is ..." and "teaching is ..." following the data analysis used in the previously mentioned studies. Each metaphor was analyzed independently by the researcher and the assistance classifier. Once independent data analysis was complete the findings were compared for inconsistencies and worked collectively to reconcile some of the inconsistencies. Although the number of metaphors was quite small, we calculated the Cohen's kappa as a measure for interrater agreement. Agreement was substantial (Cohen's kappa  $\kappa \approx 0,733$ ) for the categorization of the metaphors for mathematics using the codes Journey, Tool, Structure, and Language. As it was for categorizing the metaphors for teaching using the codes Production, Journey, Growth, and Overwhelming (Cohen's kappa  $\kappa \approx 0,793$ ). When the metaphors for mathematics teacher's role were categorized using the NorBa -project's codes teacher as Subject expert, as Didactics expert, as Pedagogical expert, Self-referential metaphors, and Contextual metaphors the agreement was also substantial (Cohen's kappa  $\kappa \approx 0,813$ ). After the categorization all the results were cross-tabulated (see Tables 1-3).

Research questions were:

- What metaphors do prospective mathematics teachers use when they refer to mathematics?
- What metaphors do prospective mathematics teachers use when they refer to teaching?
- What metaphors do prospective mathematics teachers use when they refer to mathematics teacher's role?
- Is there any pattern between metaphors for mathematics, metaphors for teaching, and metaphors for mathematics teacher's role?

## Results

Some of the metaphors were rather clear-cut, but some were opened up to various possible interpretations. Every metaphor was counted as one, but four of the students did write more than just one metaphor, and every metaphor was used. That explains why the total amount of metaphors is 19 in Table 1 and Table 3.

*Table 1. Prospective mathematics teachers' metaphors for mathematics and teaching.*

<i>Mathematics/ Teaching</i>	<i>Production</i>	<i>Journey</i>	<i>Growth</i>	<i>Overwhelming</i>	<i>Total</i>
Journey	1	-	-	1	2
Tool	-	-	1	-	1
Structure	-	2	1	2	5
Language	4	3	-	4	11
Total	5	5	2	7	19

Based on the results of categorizing the prospective mathematics teachers' metaphors for mathematics, the language metaphor was the most common metaphor (58%). A typical language metaphor included aspect "mathematics is beautiful" or "mathematics is all around us". "Mathematics is like a flower. One cannot help but fall in love with its beauty." (Student 10) Mathematics as structure was the second most prevalent category. Structure-metaphors were found in 26% of cases. Typical metaphors in this category handled "puzzles". "Mathematics is like a house of cards, the previous piece is always crucial." (Student 9) The third category was mathematics as a journey (11%). Typical

metaphors in this category handled “struggling and perceiving” or “problem-solving”. “Mathematics is like hieroglyphics. To start with they are completely incomprehensible, but as they open up, they are an interesting world.” (Student 7) The fourth category was mathematics as a tool. Only one metaphor (5%) fell into this category. “Mathematics is like a periscope. It enables special views, but at the same time offers only one particular way of interpreting the world.” (Student 15)

Overwhelming was the category into which the greatest number of teaching-metaphors were classified (37%). Most common theme was “teaching is difficult, demanding and sometimes you succeed and sometimes not”. “Teaching is like going to war! No plan can endure the contact of battle.” (Student 9) Teaching as production was coded less frequently than overwhelming and was found in fewer metaphors (26%). Production was further subdivided into two sub-themes: “teacher presenting” and “teacher transferring information”. “Teaching is like playing the piano. You must master the basics before going on to more advanced things, and practice does make perfect.” (Student 10) The categorization of the prospective mathematics teacher’s teaching-metaphors further revealed that 26% constructed a metaphor depicting a journey metaphor. The main theme in these metaphors was “counselling” or “guiding”. “Teaching is like an expedition. You have to be able to bring information to different personalities and at the same time learn something about the others as well.” (Student 11) “Teaching is like guiding a treasure seeker – all throughout their school years students seek ‘treasures’ of knowledge as the teacher guides them on the path of learning.” (Student 8) The growth metaphor for teaching was represented in the fewest number of metaphors being found in only 11% of cases. A typical growth metaphor included aspect “taking care”. “Teaching is like gardening. If you respect your plants and their needs, you will find their deeper potential and allow them in bloom.” (Student 15)

Table 2. Mathematics student teachers’ metaphors for mathematics and teacher’s role.

<i>Mathematics/ Teacher’s role</i>	<i>Subject expert</i>	<i>Didactics expert</i>	<i>Pedagogical expert</i>	<i>Self-referen- tial</i>	<i>Contextual</i>	<i>Total</i>
Journey	-	-	1	1	-	2
Tool	-	1	-	-	-	1
Structure	-	2	1	2	-	5
Language	-	3	1	4	-	8
Total	0	6	3	7	0	16



When the students were asked to describe themselves as mathematics teachers the most common metaphor (44%) used was categorized in the category self-referential (see Table 2). These metaphors merely described student teachers' personal characteristics or features. Mathematics teacher was portrayed as "excited like a foal" or "like a small plant in a precious garden" or "a ship in the fog". "As a mathematics teacher I am like a small child. I am excited to learn new things." (Student 10) Mathematics teacher as didactics expert was the second most prevalent category (38%). Typical metaphors in this category handled "a scientist testing new methods", "Navigator", or "compass". "As a mathematics teacher I am like a signpost. I lead the way and ask questions that inspires the students to choose a path and explore. There might be many various paths leading across: cycle paths, dead ends and short cuts." (Student 12) The rest of the metaphors fell into the category pedagogical expert. Metaphors like "chameleon" or "rainbow" were examples of this category. "As a mathematics teacher I am like a muse. I try to get the students ideas into circulation." (Student 16)

When examining the cross-tabulation (Table 1) three aspects can be considered important. Firstly eight of the students who described mathematics as a language either also characterized teaching as production (4/11) or as overwhelming (4/11).

"Mathematics is like the air you breathe. Everyone uses it, even without noticing."  
 "Teaching is like wading through the jungle, you might come across either the mouth of a lion or a fruit tree." (Student 2, language and overwhelming)

Secondly none of the student teachers who pictured mathematics as a structure were at the same time describing teaching as production. And thirdly, only one of the metaphors (1/19) was categorized in the "mathematics as a tool" -category.

Table 3. Prospective mathematics teachers' metaphors for teaching and teacher's role.

<i>Teaching/ Teacher's role</i>	<i>Subject expert</i>	<i>Didactics expert</i>	<i>Pedagogical expert</i>	<i>Self-refer- ential</i>	<i>Context- tual</i>	<i>Total</i>
Production	-	4	-	1	-	5
Journey	-	2	-	3	-	5
Growth	-	2	-	-	-	2
Overwhelming	-	1	2	4	-	7
Total	0	9	2	8	0	19

When examining the cross-tabulation in Table 2, also three aspects can be considered special. Firstly, half of those students whose metaphors for mathematics (4/8) were categorized in mathematics as language were using teacher metaphors categorized in the self-referential category (4/7). Secondly, three of those students whose metaphors for mathematics (3/8) were categorized in mathematics as language were using teacher metaphors categorized in the didactics expert category (3/6). And third, none of the teacher metaphors were categorized in subject expert or contextual categories.

When examining the cross-tabulation in Table 3, two aspects can be considered important. Those students (4/5) who described teaching as production were also describing teacher as a didactics expert. And students (4/7) who described teaching as overwhelming also described the teacher's role with a self-referential metaphor.

## Discussion

Studying metaphors is addictive and at the same time challenging. Metaphors are personal and personalized and they are open to many interpretations. Some of them are too ambiguous and abstract to be interpreted; and one metaphor could be interpreted differently by different researchers (Sam, 1999). The fact that mathematics is seen to be a tool, is in the line with teacher belief research, where an instrumentalist view of mathematics and mathematics teaching (Ernest, 1989) is acknowledged to be prevalent amongst new trainees (Noyes, 2006). This study was a small and positive exception. Ernest (1989) divides views of the nature of mathematics into three. Firstly, the previously mentioned instrumentalist view that mathematics is an accumulation of facts, and skills to be used, and mathematics is a set of unrelated but utilitarian rules. Secondly, the Platonist view of mathematics as a static but unified body of certain knowledge, where mathematics is discovered, not created. Thirdly, the problem solving view of mathematics where mathematics is seen as a dynamic, continually expanding field of human creation and invention, a cultural product. The Platonist view is compatible either with the language metaphor or structure metaphor. In this study 16/19 (84%) of the metaphors were categorized under these categories. One reason for this might be that these students have studied mathematics as their major or minor for two or more years before they started their pedagogical studies. The beauty of mathematics and its formalism are rooted deep in them. Perhaps this is also contributing to the fact that only one of the students referred to the utilitarian view of mathematics as a tool. Surprisingly none of the students with the mathematics as structure metaphor suggested a production metaphor for teaching. The problem solving view of mathematics (Ernest, 1989) instead

can be related to teaching as journey metaphors where the process is seen as a necessary part of mathematics. Also this view was present in this study (26%).

The metaphors for teaching after the first teaching practice in school were coloured by school experiences. Like Chang and Wu (2008) portrayed: at the beginning of his teacher career “a teacher fails to notice and realize the changes and special situations occurred within the classroom, and usually feels lost and does not know what to do; the only thing could be handled is the teaching tasks but having lots of difficulties”. Perhaps the teacher’s working environment is not very well known after the teaching practice. The students have only 16–20 practice lessons (á 75 min) and that is not much. This could be the reason why there were no contextual metaphors for the teacher’s role.

The second gradation in Chang’s and Wu’s categories is when “teacher is passively reacting to the instructional problem occurred, then usually failing to solve it effectively, and recognizing the huge gap between the teacher’s own expectation and the realistic situation in the classroom” (Chang & Wu, 2008). The first experiences from teaching practice were perhaps the reason why so many of the students (37%) used the metaphor overwhelming for teaching or self-referential metaphor for teacher’s role. Anspal & al. (2012) suggest that while student teachers develop their focus shift from oneself towards teaching methods and skills and pupils’ learning.

In previous studies the most common metaphor for teaching was the production or transmission metaphor (Reeder & al., 2009; Cassel & Vincent, 2011; Martínez & al., 2001). In this study production metaphor was used in only 26% of the teaching metaphors. Immediately after the pedagogical studies and method courses it is understandable that no subject expert metaphors were used and didactics expert metaphors were well represented (47%), and only 4/9 of those students used the metaphor “teaching as production”.

The material for the study in hand was limited so the credibility of the study must be reviewed accordingly. There was no explicit way of categorizing the metaphors either, even though a parallel classifier was used. Despite the difficulties with categorizing or analyzing metaphors they are useful for teacher educators. By letting the students recognize their profession’s metaphors, metaphors may “function as stepping stones to a new vantage point from which a teacher can look at his or her own practice from a new perspective” (Martínez & al., 2001, 974).

## References

- Allen, B. (2010). The Primary Mathematics Specialists – What Do They Think About Teaching and Learning Mathematics? In M. Joubert & P. Andrews (Eds.), *Proceedings of the British Congress for Mathematics Education*. (pp. 9–16).
- Anspal, T., Eisenschmidt, E., & Löfström, E. (2012). Finding myself as a teacher: exploring the shaping of teacher identities through student teachers' narratives. *Teachers and Teaching: Theory and Practice*, 18(2), 197–216.
- Beijaard, D., Verloop, N., & Vermunt, J. D. (2000). Teachers' perceptions of professional identity: an exploratory study from a personal knowledge perspective. *Teaching and Teacher Education* 16, 749–764.
- Cassel, D., & Vincent, D. (2011). Metaphors reveal preservice elementary teachers' views of mathematics and science teaching. *School science and mathematics*, 111(7), 319–324.
- Chang, Y. L., & Wu, S.-C. (2008). A case study of elementary beginning mathematics teachers' efficacy development. In O. Figueras, J. L. Cortina, S. Alatorre, T. Rojano & A. Sepúlveda (Eds.) *International Group for the Psychology of Mathematics Education. Mathematical Ideas: History, Education, and Cognition. Proceedings of the Joint Meeting of PME32 and PME-NA XXX, México* (Vol. 2, pp. 273-280).
- Ernest, P. (1989). *The Impact of Beliefs on the Teaching of Mathematics*. <http://people.exeter.ac.uk/PERnest/impact.htm>.
- Hannula, M.S., Kaasila, R., Laine, A., & Pehkonen, E. (2005). Structure and typical profiles of elementary teacher students' view of mathematics. In H. L. Chick & J. L. Vincent (Eds.), *Proceedings of the 29th Conf. of the Int. Group for the Psychology of Mathematics Education*. (Vol 3, pp. 41–48). Melbourne: PME.
- Hannula, M. S., Kaasila, R., Laine, A., & Pehkonen, E. (2006). The structure of studentteacher's view of mathematics at the beginning of their studies. In M. Bosch (Eds.), *Proceedings of the Fourth Congress of the European Society for Research in Mathematics Education*, (pp. 205–214). Fundemí IQS Universitat Ramon Llull.
- Kagan, D. M. (1992). Implications of research on teacher belief. *Educational Psychologist*, 27(1), 65–90.
- Lakoff, G. (1993). The contemporary theory of metaphor. In A. Ortony (Eds.), *Metaphor and thought* (pp. 202–251). Cambridge: University Press.
- Lakoff, G., & Núñez, R. E. (2000). *Where mathematics comes from: How the embodied mind brings mathematics into being*. New York: Basic Books.

- Lerman, S. (2002). Situating research on mathematics teachers' beliefs and on change. In G. C. Leder, E. Pehkonen & G. Törner (Eds.), *Beliefs: A hidden variable in mathematics education* (pp 233–243). Dordrecht: Kluwer.
- Martínez, M. A., Sauleda, N., & Huber, G. L. (2001). Metaphors as blueprints of thinking about teaching and learning. *Teaching and Teacher Education*, 17, 965–977.
- Noyes, A. (2006). Using metaphor in mathematics teacher preparation. *Teaching and Teacher Education*, 22, 898–909.
- Pietilä, A. (2002). *Luokanopettajaopiskelijoiden matematiikkakuva: Matematiikkakokemukset matematiikkakuvan muodostajina*. [Pre-service elementary teachers' views of mathematics: The role of mathematics experiences in forming the views of mathematics.] Department of Teacher Education, Research Reports 238. University of Helsinki, Finland.
- Reeder, S., Utley, J., & Cassel, D. (2009). Using metaphors as a tool for examining preservice elementary teachers' beliefs about mathematics teaching and learning. *School science and mathematics*, 109(3), 290–297.
- Sam, L. C. (1999). Using metaphor analysis to explore adults' images of mathematics. *Philosophy of Mathematics Education Journal* 12, <http://people.exeter.ac.uk/PErnest/pome12/article9.htm>
- Schinck A. G., Neale, H. W., Jr., Pugalee, D. K., & Cifarelli, V. V. (2008). Using metaphors to unpack student beliefs about mathematics. *School Science and Mathematics*, 108 (7), 326–333.
- Sfard, A. (1998). On two metaphors for learning and the dangers of choosing just one. *Educational Researcher*, 27(2), 4–13.
- Sterenber, G. (2008). Investigating teachers' images of mathematics. *Journal of Mathematics Teacher Education*, 11, 89–105.
- Wilson, M. S., & Cooney, T. J. (2002). Mathematics teacher change and development. In G. C. Leder, E. Pehkonen & G. Torner (Eds.), *Beliefs: A hidden variable in mathematics education* (pp. 127–147). Dordrecht: Kluwer.

# Finnish mathematics teachers' beliefs about their profession expressed through metaphors

SUSANNA OKSANEN AND MARKKU S. HANNULA

susanna.oksanen@helsinki.fi  
University of Helsinki, Finland

## Abstract

*The purpose of this study was to investigate Finnish mathematics teachers' beliefs about teaching and teachers as expressed through metaphors. Because teachers' beliefs play a significant role in their teaching, it is important to recognize those beliefs. Metaphors provide insights into beliefs that are not explicit or consciously held. In this study we investigated what kind of metaphors Finnish mathematics teachers in different schools and in different stages of their careers use. This study focused on Finnish 7-9 grade mathematics teachers' (n=70) metaphors about teacher. The metaphors were classified into five categories: teacher as a subject specialist, teacher as a pedagogue, teacher as a didactics expert, self-referential and contextual metaphors. Teacher as a didactic expert was the most frequently used metaphor (49%). The information gained from this metaphor analysis show teachers' beliefs about themselves. Changing teachers' beliefs can help to change teachers' behaviours and in such way improve teaching and learning process.*

## Keywords

*Teachers' beliefs, mathematics teaching, metaphors, teacher change*

## Introduction

Teachers' beliefs play a significant role in their teaching. They affect on *what* gets taught, *how* it gets taught, and *what* gets learned in the classroom. Beliefs shape how teachers think and feel about mathematics and its teaching and learning. As teachers beliefs affect their teaching, it is important to recognize those beliefs. Changing teachers' practices will depend on changing their beliefs and changing beliefs will lead to change in practices (Lerman 2002).

Metaphors are a tool for teachers to understand their work and to create meanings which are difficult to access in literal language. Therefore, metaphors are a valid source for gaining insights into teachers' thoughts and feelings regarding their

teaching (Zhao, 2009). According to Kasten (1997) metaphors would seem to have an important place in the provision of explanation. Metaphors capture and model teachers' understanding of teaching and learning. A metaphor can transfer a lot of information and describe phenomena in familiar terms so that the understanding may be deepened. Metaphors provide insights into beliefs that are not explicit or consciously held (Beijaard, Verloop and Vermunt, 2000). According to Tobin (1990) by conceptualizing teachers' beliefs and roles through metaphors they use, teacher change can be implemented.

This study focused on mathematics teachers metaphors about teachers. The purpose is to investigate Finnish mathematics teachers' beliefs about teaching and teachers as expressed through metaphors. The respondents were 94 Finnish mathematics teachers, teaching grades 7-9. The youngest teacher was 26 years old and the oldest 61 years old. The average age was 46 years. Teachers professional age was between 1-35 years (1-5 years of teaching n=23, 6-20 years of teaching n=18 and over 21 years of teaching n=26).

The teachers were asked to write a metaphor describing a teacher and an explanation: "Teacher is like ... My brief explanation of the metaphor is as follow." The results were analysed by the Manual for NorBa Project (Löfström, Poom-Valickis and Hannula, 2011). The manual is intended to support the researcher in the analysis of metaphors as research data using a theoretical framework based on Beijaard, Verloop, and Vermunt's (2000) model of teacher identity. The model is based on Schulman's (1986) ideas of teacher's content knowledge (CK), pedagogical knowledge (PK) and pedagogical content knowledge (PCK). The metaphor categorization was judged on a case-to-case basis using two independent raters whose coding was compared at the end.

## Theoretical framework

Since 1970 there has been a considerable amount of research on teachers' beliefs based on the assumption that what teachers believe is a significant determiner of what gets taught, how it gets taught, and what gets learned in the classroom. Beliefs reflect in which way mathematics and its teaching and learning are conceptualized by teachers.

### Beliefs

Pehkonen and Törner (1998) summarized that an individual's mathematical beliefs are compound of his subjective, experience-based, implicit knowledge

on mathematics and its teaching and learning. The spectrum of an individual's beliefs is very large, and its components influence each other.

Op't Eynde, De Corte, and Verschaffel (2002) define mathematical beliefs to be implicitly or explicitly held subjective conceptions people hold to be true, that influence their mathematical learning and problem solving. This view is shared by Leder, Pehkonen & Törner (2002), who define beliefs as an individual construct.

Beliefs may have a knowledge-type nature, (e.g. view of mathematics: "mathematics learning is independent on gender"), which truthfulness can be discussed in social interaction, or volitional nature (individual and subjective; such as "It is important to me to provide good experiences with mathematics"). The latter kind of beliefs' validity can never be judged socially with any "scientific criteria". Beliefs, as such, are subjective, something that an individual believes to be true, no matter whether the others agree or disagree. (Op't Eynde & al, 2002)

#### Mathematics teachers' beliefs

Today mathematics teachers' beliefs and their impact are seen as ability and tendency to change (Wilson and Cooney, 2002). Also Lerman (2002) underlines that there is a strong link between beliefs and practices: changing teachers' practices will depend on changing their beliefs and changing beliefs will lead to change in practices. *Teacher change* consist changes in classroom behavior but also in the very art of teaching.

The importance of reflection in changing teachers' beliefs has also being recognized. According to Tobin (1990) reflective thinking about teaching can change the teaching behavior and actions. In addition to reflection, teachers' ability to attend to students' understanding of mathematics and to base given instructions on what and how students are thinking is also important.

#### Metaphors

Metaphors enable people to understand one phenomenon by comparing it to something else. Metaphors affect our way of conceptualizing the world and reality whether we are aware of this phenomenon or not. It is suggested that metaphors do not of themselves prove or demonstrate anything new, but merely enable us to see in a new light what we are doing or experiencing. (Ahmet, 2006.)

The potential power of metaphors as a "master switch" to change teachers' beliefs was realized in 1990. Tobin (1990) investigated how the use of metaphors



helped teachers to conceptualize teaching roles. He found the possibility that significant changes in classroom practice are possible if teachers are assisted to understand their teaching roles in terms of new metaphors. First the metaphors are used to conceptualize teaching roles. The conceptualization of a role and the metaphor used to make sense of it is dependent on the context in which teaching and learning occurs. A metaphor used to conceptualize a teacher role can be changed in a process of changing the role. Teachers can explore and reconstruct new metaphors of teaching as a transformative route of teacher development, which leads to improvements in practice. (Tobin, 1990.)

### Teacher change

Martínez, Sauleda and Huber (2001) assume that a classroom situation will change if the teacher substitutes his or her preferred professional metaphor for another one. In this process, metaphors may function as stepping stones to a new vantage point from which a teacher can look at his or her own practice as educator from a new perspective. Moreover, metaphors may stimulate the teachers to explore new conceptual territories visible from an alternative point of view, a perspective of classroom practice which they might not have otherwise considered.

Alger (2009) studied teacher beliefs over the career span through metaphors. Analysis indicates that 63% of teachers changed their conception of teaching over time. Even 80% of the teachers in the study came into the profession with teacher-centered conceptions of teaching. This mirrors their prior educational experiences. What is perhaps the most exciting outcome of the study is the evidence that there is a reduction in teacher-centered conceptual metaphors and an increase in student-centered conceptual metaphors that represent current practice and desired practice. Some experienced teachers drift toward student-centered metaphors, which may be a function of newer types of professional development or changes in school culture. This change may also reflect larger changes in education.

### Exploring mathematics teachers' beliefs with metaphors

The Beijaard, Verloop, and Vermunt's (2000) model of teacher identity identifies three distinct knowledge bases of teacher knowledge. Teachers' professional identity can be described in terms of *teacher as a subject matter expert*, *teacher as a pedagogical expert*, and *teacher as a didactical expert*. Löfström, Anspal, Hannula and Poom-Valickis (2010) studied what metaphors first, third and fifth year university students' in Estonia use and how much agreement there is

between metaphors and the scores on the teacher identity measure by Beijaard model.

The results indicate that the model by Beijaard and colleagues can be applied as an analytical frame of reference when examining metaphors, but that it would be useful to develop and expand the model further to include metaphors categorized as *self-referential metaphors* and *contextual metaphors*. *Hybrids* may include elements of more than one of the above categories. Unidentified metaphors could not be classified in any of the categories presented above. In this study was used *The Manual for NorBa Project - Categorisation of Teacher Metaphors* (Erika Löfström, Katrin Poom-Valickis & Markku S. Hannula, 2011).

The new extended Beijaard, Verloop, and Vermunt's (2000) model of teacher identity makes the metaphor classification more clear. Self-referential and contextual metaphors can be sorted in separate groups. For example the following metaphor describes teacher as person, not as a pedagogical, didactics or subject expert: "Teacher is like *an ironwire*: twists and turns and bends but doesn't brake."

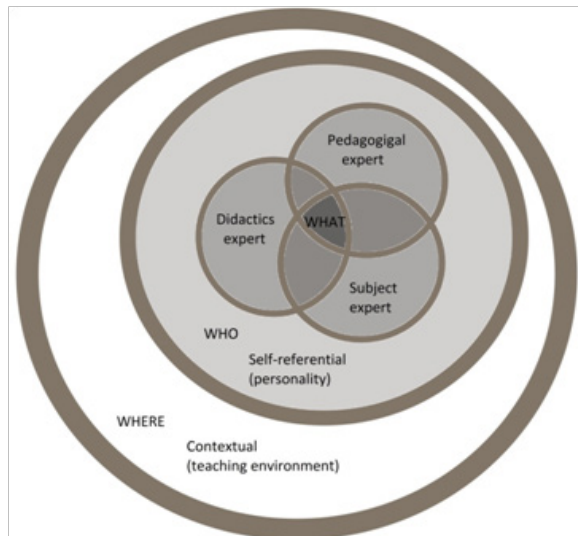

Figure 1. The new extended Beijaard, Verloop, and Vermunt's (2000) model of teacher identity.

Our research question was: What kind of metaphors and explanations do Finnish 7-9 grade mathematics teachers use when they describe a teacher?

## Methodology

### Instrument

The present research is made in connection with an international comparative NorBa study (Nordic-Baltic Comparative Research in Mathematics Education) which uses a quantitative questionnaire elaborated by project participants. A piloting of the questionnaire was carried out in three participating countries (Estonia, Finland and Latvia) at spring 2010: the total number of respondents was around 60. The questionnaire was revised according to teachers' responses and reliability calculations. Several items were removed or rephrased.

The revised questionnaire includes eight parts, seven of which are quantitative. In quantitative parts, there are 77 statements that have answering options of 5 or 4 -point Likert or Likert type scale. Part A includes items for background information.

### Procedure

The data collecting process in Finland took place in two phases: during spring 2010 (35 schools) and between November 2011 and February 2012 (61 schools). Informative letters and E-mails were sent to 106 schools all over Finland inviting mathematics teachers to participate in the polling. Teachers who wished to participate in the polling filled in applications and sent them back to the university, or used an electronic form to inform about the willingness. Participation in the polling was voluntary. Respondents' identity and records were kept confidential: the report did not disclose teachers' personal data (name, school).

### Sample

The sampling of teachers teaching grades 7-9 consisted of 94 mathematics teachers from different regions of Finland. The sample size in 2010 was 52 teachers (the questionnaire was sent to 35 schools) and in 2011-2012 42 teachers (the questionnaire was sent to 71 schools). The sample includes teachers of different ages, education level and teaching experience. Teachers filled in the survey and 70 of them presented also the metaphor.

## Analyses

The metaphor categorization was judged on a case-to-case basis using two independent raters, whose coding was compared at the end. The metaphors and their explanations were analyzed as a unit, as the metaphor itself may be used to express different meanings. The raters analyzed the metaphors “from pure towards complex”. Whether the metaphor and its explanation (unit of analysis) fitted into one of the basic categories (teacher as a subject matter expert, teacher as a pedagogical expert, teacher as a didactical expert, self-referential metaphors, contextual metaphors) or the unit of analysis contained elements of two or more aspects (hybrids) or it remained unidentified.

At the end the coding was compared. 83% (58/70) of the metaphors were categorized identically. In additionally in case of 13% (9/70) the metaphors were coded partly identically. If the unit of analysis contained elements of two or more aspects, the category used by both raters became the final category. Only 4% (3/70) were coded differently. Those three metaphors were removed (finally  $n=67$ ).

## Results

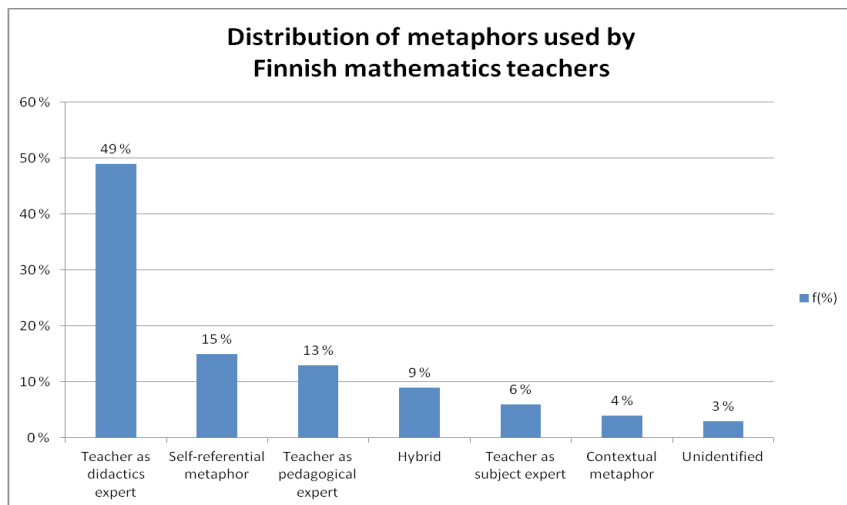

Figure 2. Metaphors used by the Finnish 7-9 grade mathematics teachers.

Distribution of metaphors used by Finnish teachers is presented in the following and in the Figure 2. Teacher as didactics expert was clearly the most common metaphor used. Almost half of the teachers (46%) saw the teacher as a didactics expert.

#### Teacher as didactics expert (49 %)

Teachers need knowledge about how to teach specific subject-related content so that pupils can capitalise their learning. This kind of knowledge is referred to as knowledge of didactics, and is integrated with an understanding of how learning experiences are facilitated in a particular subject. The teacher was described as the person who is responsible for designing her pupils learning process. In this category the typical metaphor was guide. The metaphors used: a coach, a motor and a lighthouse.

*Teacher is like a catalyst: helps students to produce knowledge in their heads.*

#### Self-referential metaphors (15 %)

These metaphors focus on what teacher represents for the respondents as individuals. These metaphors described features or characteristics of the teacher's personality, with reference either to the teacher's characteristics (self-referential) without reference to the role or task of the teacher. One might say that the metaphors described who the teacher is. The most common self-referential metaphors were connected to multi-functionality of teacher's role and the need to fulfil several tasks simultaneously. The metaphors used: a wire, an ameba, a clown, a stand-up actor.

*Teacher is like an ironwire: twists and turns and bends but doesn't brake.*

#### Teacher as pedagogical expert (13 %)

The understanding of human thought, behaviour, and communication are essential elements in the teacher's pedagogical knowledge base. Emphasis is on relationships, values, and the moral and emotional aspects of development. The teacher is seen as someone who supports the child's development as a human being. These metaphors stress teacher's role to raise or educate the child. The most common metaphor for teacher as pedagogical expert was a safe adult.

*Teacher is like a safe adult: in the classroom happens a lot more than just mathematics learning.*

### Hybrids (9 %)

In addition, we found that metaphors may include elements of more than just one of the above categories. Typically, the hybrids included the subject aspect with either pedagogical or didactical aspect.

*Teacher is like an apple. (S)he has the knowledge and (s)he knows all the facts based on the curriculum, but (s)he can also motivate students to learn.*

### Teacher as subject expert (6 %)

Teacher has a profound knowledge base in his/her subject(s) Typical metaphors in the subject expert category described the teacher as a source of knowledge. Teaching is concerned with getting across information to the students.

*Teacher is like a book, from which a students draw new information.*

### Contextual metaphors (4 %)

These metaphors described features or characteristics of the teacher's work or work environment, or in other ways referred to characteristics of the environment (contextual). One might say that the metaphors described where (physically, socially and organisationally) or in what kind of setting or environment the teacher works. The example below indicate the teacher in a social context (class with pupils), but do not reflect any specific aspects of the teacher's knowledge base. These metaphors mostly described teachers' work as too demanding, multifunctional, including too many responsibilities (pupils, parents, colleagues, heads and society).

*Teacher is like an eager beaver, because of the amount of work.*

### Unidentified metaphors (3%)

Unidentified metaphors (3%) could not be categorized in any of the categories presented above.

## Discussion

The results indicate that the new extended Beijaard, Verloop, and Vermunt's (2000) model of teacher identity can be used when categorizing teacher metaphors. Only two metaphors remained unidentified and only 4% (3/70) were

coded differently by the two independent raters. The new extended model makes the metaphor classification more clear. Self-referential and contextual metaphors can be sorted in separate groups. For example the following metaphor describes teacher as person, not as a pedagogical, didactical or subject expert: “Teacher is like *an ironwire*: twists and turns and bends but doesn’t brake.”

Teacher as didactical expert was clearly the most common metaphor used in this group of Finnish mathematics teachers. Almost half of the teachers (46%) saw the teacher as a didactical expert. According to these teachers it is important to create learning environments that support the students learning process and to use different teaching and learning methods. Learning may occur when students are actively involved and critical thinking is pursued.

Also Wilson and Cooney (2002) pointed that students learn mathematics most effectively when they construct meanings for themselves, rather than simply being told. A constructivist approach to teaching helps students to create these meanings and to learn. Constructivist teaching is interactive and student-centered. The most common didactical metaphor was “a guide”. A guide leads and motivates students but lets them to make new findings.

Presence of hybrid metaphors could be explained by complexity of a teacher’s job. Six of all Finnish mathematics teachers provided hybrid metaphors. The teacher is regarded to be a person with high moral values, good interaction skills and the goal of working for the good of others.

Gender differences were not statistically significant. The differences between the three professional-age-groups (1-5 years of teaching  $n=23$ , 6-20 years of teaching  $n=18$  and over 21 years of teaching  $n=26$ ) were not statistically significant. In all three groups teacher as didactical expert was the most common used category.

If we compare prospective mathematics teachers’ metaphors and teachers’ metaphors, some differences can be found. Portaankorva-Koivisto (2013) studied what metaphors do Finnish prospective mathematics teachers ( $n=16$ ) use when they refer to mathematics teacher’s role. The most common metaphor (44%) used was categorized in category self-referential. This refers that mathematics teachers’ beliefs differ from prospective mathematics teachers’ beliefs. It is important that the students recognize their beliefs, so that they can change them and in such way improve teaching and learning process.

Finnish mathematics teachers’ beliefs seem to be constructivist according to the metaphor analysis. However, despite the good PISA-results, the recent national

assessment shows reduction in students' mathematical skills (Hirvonen, 2011). If teachers' beliefs are constructivist, what kind of teaching approach they actually use and how are their classroom practices? As the NorBa-project continues, we will find answers to these questions.

## References

- Alger, C. L. (2009). Secondary teachers' conceptual metaphors of teaching and learning: Changes over the career span. *Teaching and Teacher Education*, 25(5), p. 743–751.
- Beijaard, D., Verloop, N., & Vermunt, J. D. (2000). Teachers' perceptions of professional identity: an exploratory study from a personal knowledge perspective. *Teaching and Teacher Education*, 16, 749–764.
- Bullough, R.V. Jr. (1991). Exploring Personal Teaching Metaphors in Preservice Teacher Education. *Journal of Teacher Education*, 42 (1), 43–51.
- Hirvonen, K. (2011). Onko laskutaito laskussa? Matematiikan oppimistulokset peruskoulun päättövaiheessa 2011. Koulutuksen seurantaraportit 2010:2, Opetushallitus. Tampere: Juvenes Print – Tampereen yliopistopaino Oy.
- Kasten, I. (1997). Metaphor and teaching. In G. Törner (Ed.), *Current state of research on mathematical beliefs V. Proceedings of the MAVI-5 Workshop. August 22 - 25, 1997*.
- Kupari, P. (1996). Changes in teachers' beliefs of mathematics teaching and learning. In G. Törner (Ed.), *Current state of research on mathematical beliefs II. Proceedings of the 2nd MAVI Workshop. Gerhard-Mercator-University, Duisburg, March 8-11, 1996. Schriftenreihe des Fachbereichs Mathematik* (pp. 25–31). Duisburg: Gerhard-Mercator-University.
- Leavy, A. M., McSorley, F. A., & Bote, L. A. (2007). An Examination of what metaphor construction reveals about the evolution of preservice teachers' beliefs about teaching and learning. *Teaching and Teacher Education*, 23, 1217–1233.
- Leder, G. C., Pehkonen, E., & Törner, G. (Eds.) (2002). *Beliefs: A Hidden Variable in Mathematics Education?* Mathematics Education Library. Dordrecht: Kluwer.
- Löfström, E., Anspal, T., Hannula, M. S., & Poom-Valickis, K. (2010). Metaphors About 'The Teacher': Gendered, Discipline-Specific and Persistent? In J. Mikk, M. Veisson, & P. Luik (Eds.), *Teacher's Personality and Professionalism. Estonian studies in Education*. Frankfurt am Main: Peter Lang Publishers House, 105–122.
- Löfström, E., Hannula, M. S., & Poom-Valickis, K. (2010). The cabbageworm in the classroom: metaphors as expressions of students' beliefs about the teacher role. In M. F. Pinto & T. F. Kawasaki (Eds.), *Mathematics*



- in Different Settings. Proceedings of the 34th annual Conference of the International Group for Mathematics Education, Vol.3, pp. 225-232. Belo Horizonte, Brazil: PME.*
- Martinez, M. A., Sauleda, N., & Huber, G. L. (2001). Metaphors as blueprints of thinking about teaching and learning. *Teaching and Teacher Education, 17*, 965-977.
- Matematiikan kansalliset oppimistulokset peruskoulun viidennen vuosiluokan jälkeen vuonna 2008 (17-70). Helsinki: The Finnish National Board of Education.
- Niemi, E. K. (2010). Matematiikan oppimistulokset 6. vuosiluokan alussa. In E. K. Niemi & J. Metsämuuronen (Eds.), *Miten matematiikan taidot kehittyvät?*
- Pehkonen, E. (1998). On the concept "Mathematical belief". In E. Pehkonen & G. Törner (Eds.) *The State-of-Art in Mathematics-Related Belief Research; Results of the MAVI activities. Research report 184*, (pp. 37-72). Department of teacher education. University of Helsinki.
- Portaankorva-Koivisto, P. (2013). Prospective mathematics teachers' metaphors for mathematics, teaching, and teacher's role. Accepted to: *Proceedings of the 18th Conference of the Mathematical Views. Helsinki, Finland.*
- Tobin, K. (1990). Changing metaphors and beliefs: a master switch for teaching? *Theory into Practice 29* (2), 122 - 127.
- Zhao, H.Q. (2009). *Developing professional knowledge about teachers*. Hangzhou, China: Zhejiang Univ. Press.

# Mathematics teachers' beliefs about good teaching: A comparison between Estonia, Latvia and Finland

MADIS LEPIK<sup>1</sup>, ANITA PIPERE<sup>2</sup> AND MARKKU S. HANNULA<sup>3</sup>

mlepik@tlu.ee

<sup>1</sup>Tallinn University, Estonia

<sup>2</sup>Daugavpils University, Latvia

<sup>3</sup>University of Helsinki, Finland

## Abstract

*The article presents results from a cross-cultural NorBa-project "Mathematics teachers' educational beliefs". We report Estonian, Latvian and Finnish lower secondary mathematics teachers' beliefs about good teaching. A principal component analyses identified a two-component structure of teachers' beliefs about good teaching: (1) Reasoning and conceptual understanding and (2) Mastery of skills and facts. Cross-cultural differences were identified in both of these dimensions. Latvian teachers indicated the strongest agreement with reasoning and conceptual understanding, Estonian teachers with mastery of skills and facts, while Finnish teachers scored lowest on both dimensions. Moreover, we analysed the amount of teachers with different profiles with regard to these two dimensions.*

## Keywords

*mathematics teachers' beliefs, belief profiles, comparative study*

## Introduction

Beliefs reflect in which way mathematics, its teaching and learning is conceptualised by mathematics teachers. Thompson states that „what a teacher considers to be desirable goals of the mathematics program, his or her own role in teaching, the students' role, appropriate classroom activities, desirable instructional approaches and emphases, legitimate mathematical procedures, and acceptable outcomes of instruction are all part of the teacher's conceptions of mathematics teaching“ (Thompson, 1992, p.135). Despite the prevalence of research into beliefs, there is still considerable debate about the definition and characteristics of beliefs (see Furinghetti & Pehkonen, 2002). In the context of this study the beliefs are

understood broadly as conceptions, views and personal ideologies that shape teaching practice. More specifically, we focus on mathematics teachers' beliefs about good teaching. It is assumed, that what one believes influences what one does – beliefs act as teacher's pedagogical predispositions. So, beliefs are factors shaping teacher's decisions, for example, about what goals should be accomplished and what should the effective learning of mathematics look like (Schoenfeld, 1998). Research suggests that many teachers begin their careers with previously constructed and possibly subconscious theories about teaching (Powell, 1992). Furthermore, as Clark (1988) suggests, teachers continue to hold idiosyncratic and implicit theories throughout their careers. Understanding teachers' decisions requires understanding not only what knowledge they possess, but also how they decide what knowledge to invoke, when, and how. Those decisions are reflections of teacher implicit theories, reflections of what teacher believes to be important and plausible (Speer, 2005).

Belief research in mathematics education focuses primarily on how teachers view the nature of mathematics, its learning and teaching, and teaching in general (Dionne, 1984; Ernest, 1991; Liljedahl, Rösken, & Rolka, 2007). Teachers' beliefs about mathematics and its teaching and learning reflect teachers' priorities for the practices of mathematics classrooms and play a significant role in shaping teachers' characteristic patterns of instructional behaviour (Thompson, 1992).

Currently it is widely assumed that teachers' beliefs about the nature of teaching and learning include both "direct transmission beliefs about learning and instruction" or, so called, "traditional beliefs" and "constructivist beliefs about learning and instruction" (OECD, 2009). The teaching approach of direct transmission implies that teacher communicate knowledge in a clear and structured way, explain correct solutions, give learners clear and resolvable problems and ensure peace and concentration in the classroom, while in constructivist classroom students are perceived as active participants in acquisition of knowledge, students' own inquiry is stressed developing problem solutions (OECD, 2009).

At the same time the implementation of teacher's beliefs into the practice is influenced by the rich context: pedagogical traditions in the country, school culture, social background of the students, etc. This makes the relationship between teachers' beliefs and their teaching practice not linear; research often reports inconsistencies between teachers' beliefs and their actions (Chen, 2008; Skott, 2009). Assuming that teaching depends also on the cultural context and that beliefs are culturally informed requires international comparative studies of teachers' beliefs. Cross-cultural differences in teacher beliefs can provide important information regarding the scope of possible classroom practice

and teacher inclination to different teaching approaches. As such, beliefs held by mathematics teachers in different countries provide an interesting window through which to study mathematics teaching in those countries. Moreover, knowledge of teacher beliefs may inform pre-service and in-service teacher education or curricular reforms. However, few studies compare teacher beliefs across countries (e.g., Andrews & Hatch, 2000; Felbrich, Kaiser & Schmotz, 2012).

## Methodology

### The context and aims of the study

The investigation reported here is part of a larger study (NorBa-study) incorporating survey of mathematics teachers in Estonia, Latvia and Finland. The objectives of this study were: to construct an instrument that can, in cross-culturally valid ways, measure aspects of teachers' beliefs concerning job satisfaction, teaching, school mathematics and mathematics didactics, and to use the instrument for an explorative study of mathematics teachers' belief structures and their possible cross-cultural differences in Baltic and Scandinavian countries.

In this paper we aim to describe Estonian, Latvian and Finnish teachers' beliefs concerning good teaching. According to the different degrees of agreement with ideas regarding components of good teaching typical belief profiles are also derived and described.

The context for this investigation is three neighbouring countries – Estonia, Latvia and Finland with different cultural, historical and educational backgrounds.

Finland is generally known in the world by its exemplary educational system. The formation for that in the field of mathematics and science education was furnished by the national LUMA-project (in 1996-2002) which was set up to enhance the learning of mathematics and sciences (Ahtee, Lavonen, Parviainen & Pehkonen, 2007). The national ethos of the time was inspired by the rise of Nokia, generating a vision of Finland as a high-tech economy. As a surprise for Finns, Finland scored to the top in PISA achievement scores in 2000 and the following measures.

Since regaining their independences in 1991, Estonia and Latvia have gone through many changes that affected also the educational system in these countries. While natural sciences and mathematics were emphasised in the Soviet curriculum, the focus has shifted towards other topics. Also the attractiveness of

teacher profession has fallen considerably. According to the international TALIS study Estonia belong to the group of countries where teachers support most the use of innovative teaching practices. The last PISA survey results (OECD, 2010) also indicate good student performance, internationally Estonian pupils excel on their performance in reading literacy as well as in science and mathematics.

In 2006 and 2008 new standards in basic and secondary education were introduced in Latvia. These reforms as well as the ESF project “Elaboration of the Content of Learning and Teacher Further Education in the Subjects of Natural Sciences, Mathematics and Technologies” (2008-2013) changed the philosophy of Latvian education system by introducing the fundamental principles of holism and constructivism.

According to the PISA 2009 results Finnish school mathematics proves to be among the best (average score=541). Estonian pupils scored significantly higher (average score= 512) and Latvians lower (average score= 482) than the OECD average (496) (OECD, 2010).

The three countries have similar school system in several aspects. Pupils start schooling at the age of six or seven years, and compulsory school lasts nine years in each country. In compulsory school, pupils most often study in mixed-ability groups as there is no tracking.

### Participants

The data was collected from the 7-9th grade mathematics teachers in Estonia (N=333), Latvia (N=390) and Finland (N=92). Thus the overall sample size is 815 teachers. The data collection has been completed in fall and winter 2010/2011.

The age of Estonian teachers ranged from 25 to 77 (M=47). Length of service of these teachers ranged from 1 to 59 years (M=22). The age of Latvian teachers ranged from 25 to 66 years (M=46). Length of service ranged from 1 to 44 years (M=23). The age of Finnish teachers ranged from 25 to 61 years (M=42). Length of service ranged from 1 to 35 years (M=14).

### Instrument

The questionnaire module consisting of 16 Likert-type items identified as typical for different teaching approaches served as the main instrument for the investigation reported here (see Table 1). Teachers responded to each item using a 5 point Likert-scale from fully disagree to fully agree. Initially the questionnaire

was devised in English and then adequately translated into the languages of participating countries. A back translation was used to make the translation as similar to the original as possible. However, the transfer of educational vocabulary across different educational systems may create certain inconsistencies. A piloting of the questionnaire was carried out in three participating countries in spring of 2010; the total number of respondents was around 60. The questionnaire was revised in the light of teachers' responses and reliability calculations. Several items were removed or rephrased. The theoretical background, development and structure of the questionnaire are described in more thoroughly in our previous paper (Lepik & Pipere, 2011).

## Results

### Comparing Estonian, Latvian and Finnish teachers' responses

Teachers' responses revealed the following similarities and differences in their general beliefs about good teaching (Table 1). According to the country averages teachers agreed with 11 items and stayed neutral towards 5 items. Teachers in all countries indicated a strong support for constructivist ideas, while at the same time, their preferences for traditional ideas were split into three equal groups (accepting/neutral/denying).

*Table 1. Teachers' average responses (means and standard deviations) by countries and the statistical significance of between country differences.*

<i>Items (Factor)</i>	<i>Lat</i>	<i>Est</i>	<i>Fin</i>	<i>U*</i>
	<i>M</i> ( <i>SD</i> )	<i>M</i> ( <i>SD</i> )	<i>M</i> ( <i>SD</i> )	
The students' real-life problems and future life serve as a meaningful context for the development of their knowledge (F1)	3.87 (.945)	4.16 (.796)	4.24 (.652)	.000*
Instruction should be built around problems with clear, correct answers, and around ideas that most students can grasp quickly (F2)	3.45 (1.037)	3.18 (.941)	2.90 (.995)	.000*
How much students learn depends on how much background knowledge they have - that is why teaching facts is so necessary (F2)	3.13 (1.020)	3.52 (.869)	3.24 (.965)	.000*

Effective/good teachers demonstrate the correct way to solve a problem (F2)	2.96 (1.114)	2.90 (1.040)	2.91 (.927)	.000*
My role as a teacher is to facilitate students' own inquiry (F1)	4.71 (.562)	4.17 (.811)	4.23 (.697)	.000*
Students learn best by finding solutions to problems on their own (F1)	4.07 (.884)	4.16 (.804)	4.21 (.764)	.363
Students should work on practical problems themselves before the teacher shows them how they are solved (F1)	4.48 (.737)	4.46 (.710)	3.96 (.769)	.000*
Teacher should direct students in a way that allows them to make their own discoveries (F1)	4.67 (.588)	4.45 (.639)	4.43 (.617)	.000*
In order to facilitate student's conceptual understanding the teacher should vary methods accordingly (according to the situation) (F1)	4.66 (.607)	4.60 (.581)	4.55 (.635)	.071
Students should engage in collaboration in small groups explaining newly developing ideas and listening to other students' ideas (F1)	4.27 (.800)	4.31 (.787)	3.72 (.918)	.000*
Thinking and reasoning processes are more important than specific curriculum content (F1)	3.91 (.815)	3.85 (.885)	4.02 (.770)	.215
Most activities require the use of previous knowledge and skills in new ways (F1)	4.04 (.770)	4.03 (.828)	4.05 (.652)	.954
Teacher should emphasize the use of knowledge and skills obtained in other disciplines to solve problems and address issues (F1?)	4.47 (.704)	4.51 (.606)	3.90 (.865)	.000*
Students and their teachers create the assessment criteria and/or tools together (F1)	3.34 (.990)	3.02 (1.04)	2.71 (.908)	.000*
Assessment should include practical problems, projects and investigations (F1)	3.81 (.926)	3.95 (.950)	3.46 (.954)	.000*
A quiet classroom is generally needed for effective learning (F2)	3.33 (.981)	3.94 (.918)	3.01 (1.053)	.000*

\*Significance is calculated using Monte Carlo Sig. (2-tailed); 99% confidence interval

In general, agreement was strongest toward the following constructivist-oriented statements:

- My role as a teacher is to facilitate students' own inquiry;

- Students should work on practical problems themselves before the teacher shows them how they are solved;
- Teacher should direct students in a way that allows them to make their own discoveries;
- In order to facilitate student's conceptual understanding the teacher should vary methods accordingly;
- Teacher should emphasize the use of knowledge and skills obtained in other disciplines to solve problems and address issues.

It can be seen that teachers in all three countries tend to support the idea of discovery learning and problem solving in real life context and aim at facilitating students' conceptual understanding (70...99% of Finnish, Estonian and Latvian teachers agreed with those statements).

At the same time differences in Estonian, Latvian and Finnish teachers' responses appeared to be statistically significant in the case of 12 items related both to constructivist and traditional ideas. Biggest differences between the countries appear in connection to the following items:

- How much students learn depends on how much background knowledge they have – that is why teaching facts is so necessary;
- My role as a teacher is to facilitate students' own;
- A quiet classroom is generally needed for effective learning.

Estonian teachers agree less with using inquiry and emphasize more facts and quiet classrooms than teachers in other countries. In Latvia one third of teachers deviates from the general trend of the three countries as they de-emphasize reasoning processes and background knowledge. Finnish teachers focus much less on formulas and procedures, Latvian teachers more often relate mathematics to the daily life of students and use group work more often, and Estonian teachers emphasize non-routine problems slightly more compared to teachers in the other two countries.

### Principal component analyses

The 16 items of the questionnaire were subjected to a Principal Component Analysis (PCA). Analyses were at first performed on joint sample of teachers. The number of factors extracted was determined by eigenvalues and scree diagrams. Based on these criteria it was decided to explore solutions of four, three and two factors. The best solution (easiest to interpret) was found in two-component structure. The two-component solution explained a total of 32% of the variance.



The first factor (F1) was labelled as **Reasoning and conceptual understanding** ( $\alpha=.73$ ). Twelve items comprising this factor represent a perspective on (mathematics) teaching which emphasizes the students' active and meaningful participation in learning process: students' discoveries and inquiry on problems and real life applications, working in small groups; aiming at conceptual understanding.

The second factor (F2) was labelled as **Mastery of skills and facts** ( $\alpha=.58$ ). Although the reliability of this factor was not satisfactory, we decided to use it for reducing data complexity. However, results of consecutive analyses need to be interpreted with care. The four items of this factor emphasize the formal teaching of skills and fluency through practice of routine procedures; the teaching is first and foremost the direct transmission of knowledge from the teacher to the pupil.

It is interesting that constructs described by factors 1 and 2 appeared as independent components and not as opposite extremes of one scale. So, in case of concrete teacher they both may exist in parallel. For example, teacher who emphasizes reasoning and conceptual understanding in her teaching may value highly also practicing of routine procedures.

#### Cross-cultural comparison of factor models

Principal component analyses were performed also on sub-samples of each participating country. Factor models for the joint sample and three national cohorts proved to be almost identical. Alpha coefficients for the combined sample and for each national cohort are presented in Table 2.

*Table 2. Cronbach alpha coefficients for both factors in the combined sample and each national cohort.*

	<i>All</i>	<i>Est</i>	<i>Lat</i>	<i>Fin</i>
DF1	.73	.68	.74	.81
DF2	.58	.51	.66	.40

So, seems that conceptions of good teaching held across national educational systems in Estonia, Latvia and Finland have similar structures. However, the second factor proves reliable only in the Latvian sample while in Finland this dimension has low reliability. Despite the concerns regarding reliability, we

decided to use derived factors to compare teachers' beliefs in our countries. Country averages for factor scores are presented in Table 3.

*Table 3. Comparison of factor score averages (mean scores and standard deviations) by countries.*

<i>Factor</i>	<i>Est</i>		<i>Lat</i>		<i>Fin</i>		<i>Sig</i>
	<i>M</i>	<i>SD</i>	<i>M</i>	<i>SD</i>	<i>M</i>	<i>SD</i>	
Reasoning and conceptual understanding	4.13	.42	4.20	.40	3.95	.44	.000*
Mastery of skills and facts	3.38	.61	3.22	.74	3.02	.59	.000*

All country scores proved to differ significantly ( $p=.000$ ) by all possible pairs of countries in case of both factors. As can be seen from Table 3 teaching approach stressing reasoning and conceptual understanding is generally supported by the teachers in all three countries. The support is strongest in Latvia. In all three countries teachers tend to stay neutral towards instrumental or transmission approach (mastery of skills and facts). The strongest support to this approach appears to be among the Estonian teachers.

### Belief profiles

According to the factor model depicted above, teachers' beliefs about good teaching can be described using a two-component structure. In case of the individual teachers these two components may exist in parallel. According to the different degrees of agreement with ideas regarding these two factors, typical belief profiles could be derived. By fixing three possible values (disagree, neutral, agree) on both scales it is possible to form nine profiles (Table 2). These belief profiles describe different models of teachers' conceptions of good mathematics teaching.

As can be seen from the percentages in Table 2, teachers' distribution between these 9 profiles proved to be highly uneven. Moreover, there are interesting differences between countries with regard to their teachers' profiles (Table 3).

Table 4. Percentage of teachers in nine different belief profiles.

		<i>Mastery of skills and facts</i>		
		Disagree	Neutral	Agree
Reasoning and conceptual understanding	Disagree/neutral	1%	4%	2%
	Agree	13%	40%	24%
	Fully agree	4%	8%	5%

Table 5. Percentage of teachers in nine different belief profiles in Latvia, Estonia and Finland.

		<i>Mastery of skills and facts</i>		
		Disagree	Neutral	Agree
Reasoning and conceptual understanding	Disagree/neutral	Lat: 1%	Lat: 2%	Lat: 2%
		Est: 0%	Est: 5%	Est: 2%
		Fin: 3%	Fin: 11%	Fin: 2%
	Agree	Lat: 15%	Lat: 37 %	Lat: 24%
		Est: 10%	Est: 42 %	Est: 26%
		Fin: 17%	Fin: 47 %	Fin: 10%
Fully agree	Lat: 6 %	Lat: 8%	Lat: 5 %	
	Est: 1 %	Est: 9%	Est: 5 %	
	Fin: 4%	Fin: 4%	Fin: 1 %	

In the following, some examples of different profiles are presented.

Modest compromise (centre). The biggest group of teachers representing this profile: 326 teachers (Estonians – 42%; Latvians – 37%; Fins – 47%). These teachers compromise both approaches; their views about good teaching include transmission of knowledge in combination with construction of knowledge. They stay neutral towards formal training of skills but are not enthusiastic towards the use of discoveries, discussions and small group activities.

Radical traditionalists (top right). About 2% of teachers from all three countries belong to this group. These are the teachers who tend to see the most important goal of mathematics instruction in formal training of skills. They value teaching through practicing of routines, the teaching is considered first and foremost the direct transmission of knowledge from the teacher to the pupil.

Reconciliation of polarities (bottom right). 5% of all teachers (Estonia – 5%, Latvia – 5%, Finland – 1%) form the group of teachers believing into both approaches in parallel. So, most probably they emphasize teaching activities aiming at developing conceptual understanding and at the same time value highly instrumental part of mathematical knowledge and stress training of routines and learning of facts and skills.

## Discussion and conclusions

Teachers' beliefs reflect in which way teaching and learning is conceptualised in different countries. Cross-cultural differences in teachers' beliefs can provide important information regarding the scope of possible classroom practice and teachers' inclination to different teaching approaches. Already, TIMSS and PISA studies have shown that the mathematical attainment of Finnish, Latvian and Estonian pupils are different. Therefore, it would be relevant to assume that also the teachers' beliefs and classroom behaviour would somehow differ in these countries. The results demonstrate that the so-called traditional teaching that emphasizes routines, and modern, constructivist teaching methods are not seen by the teachers as two opposites. Rather, these two approaches are seen as competing alternatives, and in our sample we found teachers who disagreed with both as well as teachers who agree with both. However, the real distinctions in belief profiles found between countries ask for further in-depth investigation, asking, for instance, do these beliefs really dovetail with educational and other interrelated contexts and systems in given country to obtain the best outcomes? It would be interesting to compare if this parallel factors approach works also for the teachers of other subjects, as it is clear that mathematics with its specific history and philosophy of discipline would be exception in this regard.

The country comparison indicates Latvian teachers to emphasise the constructivist teaching beliefs most, while Estonians were the strongest supporters for the traditional beliefs. On the overall level, Finland agreed the least with both of these approaches. However, more detailed analysis indicates certain items that Finnish teachers agree with more than their Estonian or Latvian counterparts.

Further research in a framework of NorBa project will be related to the finalizing the data collection and analysis in other project countries (Lithuania, Norway) in order to extend the scope of relevant cross-cultural comparisons.

## Acknowledgements

The study was supported by the European Social Fund Programme Eduko (grant no. 1.2.0302.09-0004).

We also thank Kirsti Kislenko for her assistance with data analysis.

## References

- Ahtee, M., Lavonen, J., Parviainen, P., & Pehkonen E. (2007). Influential factors outside of school. In E. Pehkonen, M. Ahtee, & J. Lavonen (Eds.), *How Finns learn mathematics and science* (pp. 87-97). Rotterdam: Sense.
- Andrews, P., & Hatch, G. (2000). A comparison of Hungarian and English teachers' conceptions of mathematics and its teaching. *Educational Studies in Mathematics*, 43(1), 31-64.
- Chen, C.-H. (2008). Why do teachers not practice what they believe regarding technology integration? *The Journal of Educational Research*, 102(1), 65-75.
- Clark, C. (1988). Asking the right questions about teacher preparation: Contributions of research on teacher thinking. *Educational Researcher*, 17, 5-12.
- Dionne, J. (1984). The perception of mathematics among elementary school teachers. In *Proceedings of the sixth annual meeting of the PME-NA* (pp. 223-228). Madison: University of Wisconsin.
- Ernest, P. (1991). *The philosophy of mathematics education*. The Falmer Press: London.
- Felbrich, A., Kaiser, G., & Schmotz, C. (2012). The cultural dimension of beliefs: an investigation of future primary teachers' epistemological beliefs concerning the nature of mathematics in 15 countries. *ZDM* 44 (3), 355-366.
- Furinghetti, F., & Pehkonen, E. (2002). Rethinking characterizations of beliefs. In G. C. Leder, E. Pehkonen, & G. Törner (Eds.), *Beliefs: A hidden variable in mathematics education* (pp. 39-58). Dordrecht, The Netherlands: Kluwer.
- Lepik, M., & Pipere, A. (2011). Baltic-Nordic comparative study on mathematics teachers' beliefs: Designing research instrument to describe the beliefs and practices of mathematics teachers. *Acta Paedagogica Vilnensia*, 27, 115-123.

- Liljedahl, P., Rösken, B., & Rolka, K. (2007). Analyzing the changing mathematical beliefs of preservice elementary school teachers. In K. Hoskonen & M. S. Hannula (Eds.), *Current state of research on mathematical beliefs XII* (pp.71-82). University of Helsinki.
- OECD (2009). *Creating effective teaching and learning environments: First results from TALIS*. Paris: OECD Publishing.
- OECD (2010). PISA 2009 results: What students know and can do: Student performance in reading, mathematics and science (Volume I). PISA, OECD Publishing.
- Powell, R. R. (1992). The influence of prior experiences on pedagogical constructs of traditional and nontraditional preservice teachers. *Teaching and Teacher Education*, 8, 5-9.
- Schoenfeld, A. H. (1998). Toward a theory of Teaching-In-Context. *Issues in Education* 4(1), 1-94.
- Skott, J. (2009). Contextualising the notion of 'belief enactment'. *Journal of Mathematics Teacher Education*, 12, 27- 46.
- Speer, N. M. (2005). Issues of methods and theory in the study of mathematics teachers' professed and attributed beliefs. *Educational Studies in Mathematics*, 58, 361-391.
- Thompson, A. G. (1992). Teachers' beliefs and conceptions. In D. A.Grouws (Ed.), *Handbook of research on mathematics learning and teaching* (pp. 127-146). New York: Macmillan.



# **Out-of-field teaching mathematics teachers and the ambivalent role of beliefs – A first report from interviews**

MARC BOSSE AND GÜNTER TÖRNER

marc.bosse@uni-due.de  
University of Duisburg-Essen, Germany

## **Abstract**

*This inquiry deals with mathematics teachers without formal education for teaching mathematics and the affective-motivational components of their professional competence. It provides insights into those teachers' worldviews towards mathematics and mathematics education and indicates that cognitive as well as affective-motivational characteristics can limit these teachers' actions. The observations made during guided interviews are analyzed with reference to Alan Schoenfeld's theoretical framework of goal-oriented decision-making (Schoenfeld, 2011). Finally, our conclusions lead to recommendations for designing in-service training programs for these teachers.*

## **Keywords**

*out-of-field teaching, professional competence, affective-motivational characteristics, goals, beliefs, orientations, knowledge, resources, decision making, worldviews, mathematical thinking, emotions, affects, qualitative study, interviews*

## **Introduction and Motivation**

It is an internationally widely reported phenomenon that mathematics is often taught by out-of-field teachers, i.e. teachers who have not been educated as mathematics teachers at university and thus might possess shortcomings concerning content knowledge (CK) as well as pedagogical content knowledge (PCK). In Germany – for example – we know that more than 80 % of primary teachers have not attended mathematics courses at university – for various reasons, although there is a tendency to change this situation by means of study regulations.



We would like to point out that many of these teachers are often highly committed to teaching and in most cases are willing to teach mathematics, although the principal might demand also unwilling teachers to teach mathematics. Since in Germany nearly all teachers have to teach at least two subjects, professional teachers possess a solid basis in methodology and general didactics with respect to the students of their school type.

In other school types the percentage of out-of-field teaching mathematics teachers is not as high as in primary grades, however, it is by no means negligible. As there is a shortage of mathematics teachers, even in the lower secondary grades we estimate that about 15 % of the teachers are not originally educated as mathematics teachers. On the other hand, since principals are responsible for organizing the teaching resources in their school, ministerial administration is seldom involved, and so the problem is concealed. It is easy to understand that a school is not willing to discuss its limitations in daily school management in public.

In countries other than Germany, there are several papers devoted to the problem of out-of-field teaching (Ingersoll, 1998; Ingersoll, 2001) and the issues are often discussed in the context of minor qualifications or under-qualifications of teachers (Ingersoll, 1999; Friedman, 2000). However, these reports address school subjects in general, not exclusively mathematics. Recently, the second author took a first inventory of the German school system – with respect to mathematics (Törner & Törner, 2012). Nevertheless there is a shortage of research publications on this topic.

In addition, there is also a shortage of remedies to attenuate the problems induced by this situation. We are aware of the fact that some courses are offered to qualify teachers - but which are customer-oriented, sustainable and successful initiatives, to be recommended for in-service teacher training courses? Thus, our talk will be divided into three parts.

*First*, we will give some description on possible grounded theories which help to model our virtual ‘workplace.’ It is more than a hypothesis – and confirmed by first interviews: we do not only have to focus on the cognitive elements in a teacher’s knowledge account in terms of the subject matter knowledge (Shulman, 1985; Shulman, 1986; Bromme, 1992; Weinert, 1999) and in so doing on the missing elements and shortcomings. Moreover, we must pay attention to the affective-motivational components, among which are convictions, beliefs and elements of motivation and self-regulation, last not least emotions.

*Second*, we will present some results we have gained by leading semi-structured qualitative interviews with this group of teachers. As the scope of this paper is limited, we will only report the most important results.

*Third*, we will draw some conclusions for designing in-service training courses for this group of teachers. Actually, we believe that these courses ought to incorporate at least three elements which may be regarded as our starting hypothesis. These components are all intertwined with beliefs:

1. Textbooks in the hands of these teachers are important and indispensable. How to instruct out-of-field teachers to use textbooks is a non-trivial question.
2. Next, the teachers under discussion often lack a direct approach to the 'heart' of mathematics, problem solving. Thus, actively practicing mathematics is substantial to change views on mathematics.
3. Finally, since we believe that mathematics is a highly emotional enterprise, we have to discuss how to handle affects and emotions and thus propagate an open approach to mathematics by which we promote pluralistic worldviews on mathematics.

## Grounded Theories

### Professional Competence of Mathematics Teachers

We have to be aware that out-of-field teaching mathematics teachers are well-trained professional educators and teachers for other subjects than mathematics. Besides, some of them are highly motivated and enthusiastic to teach mathematics out-of-field. Even though those teachers might never have been trained to be professional mathematics teachers, we need to analyze their specific professional out-of-field teaching. Therefore we have to model those teachers' professional competence.

According to Blömeke, Suhl, and Döhrmann (2012), teachers' competences can be modeled by using a so-called *competence profile*. The authors refer to Shulman (1985; 1986), Weinert (1999), and Bromme (1992) as content knowledge, pedagogical content knowledge, and general pedagogical knowledge (PK) are included in the model as cognitive components. Moreover, Blömeke et al. underline that beliefs about the subject and about education in school, professional motivation, and self-regulation form a second branch of teachers' professional competence. If we want to understand and characterize out-of-field teaching, we have to have a look at these characteristics, too.

### Affective-Motivational Characteristics

Blömeke et al. explain that affective-motivational characteristics play an important role as they influence the out-of-field teaching mathematics teachers' perception of mathematics lessons. Further, they emphasize that the cognitive components are also affected by beliefs, emotions, and professional motivation. On the other hand, the affective-motivational components are influenced by (shortcomings in) the cognitive domain. Therefore, we suppose that it is exactly these affective-motivational competence-facets that differ from those of 'regular' mathematics teachers and have to be considered particularly with regard to in-service training programs. We think that training out-of-field teaching mathematics teachers in topics related to cognitive components is not enough.

### A Theory of "Teaching-In-Context"

Obviously, we need to describe the aforementioned interdependence between cognitive and affective-motivational components more precisely. In order to do this, let us have a look at Schoenfeld's theory of "Teaching-In-Context" (Schoenfeld, 1998): Schoenfeld assumes that teachers' actions and decision-making depend on three categories: *Knowledge*, *Goals* and *Beliefs*. Therefore, the theory is here abbreviated as *KGB framework*. This theoretical framework considers affective-motivational components by including beliefs as well as cognitive components by taking account of knowledge.

Every single category is influenced by the current educational context in which a teacher acts. The context of our interest in this inquiry is *teaching mathematics out-of-field*. According to Schoenfeld such a context activates context-corresponding beliefs, goals and knowledge, i.e. action plans and *scripts* in terms of Sherin, Sherin, and Madanes (2000).

According to Schoenfeld (1998), beliefs "are mental constructs that represent the codifications of people's experiences and understandings" and "shape what they [the people] perceive in any set of circumstances [...] [or] what they consider to be possible or appropriate in those circumstances" (p. 21). In this context beliefs can be about teaching mathematics, mathematics itself, or students learning mathematics. Schoenfeld emphasizes that teachers' goals are shaped by the beliefs on the one hand – on the other hand goals can be limited or defined because of missing or available knowledge.

## Orientations and Resources

In 2011 Schoenfeld offered a conceptual extension of his theory by substituting the terms *Knowledge* and *Beliefs* by *Resources* and *Orientations* (Schoenfeld, 2011), here abbreviated as *RGO framework*. In the following the main conclusions of this extension will be described in detail.

Concerning the usage of the term *orientations* Schoenfeld explains (p. 29):

*How people see things (their 'worldviews' and their [more specific] attitudes and beliefs about people and objects they interact with) shapes the very way they interpret and react to them. In terms of socio-cognitive mechanism, people's orientations influence what they perceive in various situations and how they frame those situations for themselves.*

Further, Schoenfeld underlines once again (p. 29) that context-specific orientations “*shape the prioritization of the goals that are established for dealing with those situations and the prioritization of the knowledge that is used in the service for those goals*”.

We use the term *orientations* in this manner, as an inclusive term, which means that we intend to describe the teachers' preferences, attitudes, and beliefs on many different levels and to gain insight in teaching out-of-field as widely as possible. That is when we use the term *orientation*, we do not have to be as narrow as when exclusively speaking of *worldviews*, exclusively using the term *beliefs*, or exclusively describing *attitudes* and so forth. It is the first time that we have used this terminology in interviews and we are convinced that this term is flexible as well as precise.

Moreover, Schoenfeld moves away from knowledge as the only resource for “solving problems, achieving goals, and performing other such tasks” (p. 25). He explains that intellectual, material, and social resources each play a role if we want to analyze people's actions – which particularly applies to teaching.

If Schoenfeld speaks of *individual knowledge* as one intellectual resource, he defines knowledge without claiming that this knowledge is necessarily correct. That means if a teacher makes a decision while teaching mathematics or defines goals for teaching mathematics, knowledge as a resource may be (mathematically, didactically,...) incorrect. In this effect such incorrect knowledge can contribute to the way of teaching and especially to the way of teaching out-of-field. That usage of the term *knowledge* is helpful for our purposes as we expect deficits

in the cognitive components of the out-of-field teaching mathematics teachers' professional competence.

### Emotional Consequences

Last but not least we are interested in possible emotional consequences which involve teaching mathematics out-of-field. As Schoenfeld is not explicit about the role of emotions in his KGB (or RGO) framework, we have to add another theoretical perspective. One theory offering this option is the *rational-emotive behavior therapy* (REBT) by Albert Ellis (1994).

He explains that neither the context (teaching mathematics out-of-field) itself, nor the activating objects in the context (practicing mathematics) themselves, nor the acting people themselves (students in the mathematics lesson) are responsible for an individual's (out-of-field teaching mathematics teacher's) emotions but the *beliefs* about the situation, the corresponding objects and the involved persons are the reason for affects.

We can use this explanation for emotions by saying that the context-based orientations of an individual in terms of Schoenfeld can lead to affects and emotions.

### Methodological Considerations

In the very first phase of our research activities, we needed to choose a research method capable of fulfilling the following tasks:

a) The research method should allow us to clarify if it is useful to characterize specific orientations of out-of-field teaching mathematics teachers. Further, we have to keep an open mind and stay on the lookout for other interesting related questions in the scope of our research. Clarifying the choice of questions and discovering new fields of research should be done in one step. Thus, a high grade of flexibility is needed when gathering data.

b) We aim at analyzing emotions and affects which can be communicated nonverbally. In order to achieve this we need a research method with which we can gather video data. The videos show the teachers in the exact moment when they talk about their orientations.

For these reasons, we decided to lead qualitative, semi-structured, video-based face-to-face interviews with the help of an interview-guideline (cf. Lamnek,

2010). On the one hand, the guideline provides us with the possibility of discussing different questions concerning orientations. If it becomes clear that one of these is not helpful when characterizing the out-of-field teaching mathematics teachers' orientations, the interview item can be left out. An item can also be neglected for individual reasons, e.g. when it becomes obvious that a specific question is irrelevant in a certain type of school, a certain federal state, or just in the specific professional life of the interviewee. On the other hand, the frame of the interview-guideline can be adapted if an interesting new question occurs during the interview.

By mainly asking open questions, the affects and emotions of the interviewees can be observed. These data may also become obvious in facial expressions or gestures.

The data gathered by the interviews is analyzed in four steps. First, the interviews are transcribed. In the second step, different named orientation objects, i.e. people, things, and entities that teachers can be oriented to as defined by Schoenfeld (see above) are identified and categorized. Third, the observed orientations towards these different object-categories (e.g. Mathematics, mathematical applications, textbooks, colleagues) are noted for each interviewed teacher. If the interviewee shows emotions concerning a specific orientation, it will be recorded, too. In the last step, the structured and categorized data is tested for patterns and correlations.

The interviews were led in three different federal states in Germany and took about thirty minutes each, owing to the limited time. Altogether we interviewed nine out-of-field teaching mathematics teachers of different types of school: primary school ( $n=2$ ), middle-school ( $n=5$ ) and comprehensive school ( $n=2$ ). The interviewees took part voluntarily. Five of them were asked because they attended (different) in-service training courses. We have to consider these circumstances as the teachers' orientations may have been affected by the training.

## Observations

### Orientations towards Mathematics and Mathematics Education

We must underline that the interviewed teachers see mathematics primarily in educational contexts: Their orientation towards mathematics is exclusively restricted to the mathematical content they are confronted with in school, lessons, or in-service training. Nobody referred to mathematical applications or topics out of curricular contexts or out of the everyday life of their students. Therefore,

we can assume: When the interviewees refer to mathematics, they mainly refer to its educational role in the teachers' individual occupational domain. They technically neglect mathematics in economy, technology, philosophy, science and so forth. When we asked for a definition of mathematics, every interviewee explained mathematics as something logical and referred to its structural nature and logical way of thinking. In this context we observed *three* different types of orientations:

Teachers with *orientations of type "A"* pessimistically think that mathematics is something logical, structured, and abstract without relevance for any field of everyday life (or possible applications). They do not see any kind of sense in dealing with mathematics due to missing relevance for the normal course of life.

Teachers with *orientations of type "B"* also think that mathematics is something logical and structured. But they further conclude that because of these features mathematics is a tool you can use for solving problems and dealing with various applications (e.g. banking, paying when shopping, traveling by train or bus, painting walls). The teachers primarily named applications with relevance in everyday life. Only one of them referred to the job-preparing function of mathematics education.

Teachers with *orientations of type "C"* explained that mathematics is something logical and structured. For them mathematics is also a tool but they realize that mathematics is not only a tool you can use for given problems and applications but an instrument for discovering their surroundings and making the world accessible. They emphasize the potential of doing research with mathematics and they mention mathematical objects, e.g. numbers, as a means for exploring the world.

As type "B" contains type "A" and as type "C" contains "A" and "B", we have christened this system *onion model*: The orientations towards mathematics, i.e. the mathematical thinking and the view of mathematics develop, grow and mature.

When the interviewees are specifically asked if mathematics plays a role in their students' life today, they express the opinion that it is something which is meaningful in school but it is not something they really need for 'surviving' in society. Even types "B" and "C" modify their orientations (also admitting that some basics have to be learned). It seems to make a difference if teachers refer to the role mathematics generally plays in a normative perspective or if they refer to the role mathematics plays for students they know personally.

## Teachers' Actions Are Limited

### *Mathematical Approaches, Modeling and Applications*

It could be observed that every teacher interviewed has shortcomings in the process-related competences of mathematical modeling and applications. Most of the teachers are aware of their cognitive deficits and complained as follows:

*Interviewee 1: "I lack the expertise to find applications. Where in everyday life can I find illustrative and suitable examples?"*

*Interviewee 2: "It is hard for me to implement applications in my lessons, although I attach importance to it."*

*Interviewee 3: "The children are quite good in solving 13 problems of the same type with the same strategy. But I urgently need ideas how to implement [new] applications."*

These observations are in line with what Schoenfeld (2011) says, when he emphasizes that shortcomings in the resource category lead to problems in achieving goals.

But not only deficits concerning knowledge respectively concerning resources limit teachers' actions. We observed that deficient orientations also result in inadequate defining of goals:

*Interviewee 3: "Mathematics is very, very clearly structured. There is no grey, there is mainly black and white. Right and wrong. It is relatively clear which tool to use for solving a specific problem."*

Those black-and-white orientations towards problem-solving and mathematical approaches prevent teachers from teaching a manifold picture of how to use mathematics for modeling in real life contexts. In other words we observed that limited orientations also prevent a teacher from defining and achieving desirable and adequate educational goals. One interviewee was aware of this problem and told us:

*Interviewee 4: "In mathematics education, if I [...] don't see that there are other approaches than the one I had in mind and I insist on my approach, then I can ruin a lot."*



Another one added that she had problems finding alternative approaches and implementing students' approaches she did not expect to encounter in lessons.

It also became clear during the interviews that it is worthwhile to have a look at teachers' affective-emotional characteristics, too. One teacher told us, for example, that she could mathematically handle powers and fractions and that it was no problem for her. That means we can assume no shortcomings in the individual knowledge category. Afterward we asked what she thought of fractions and powers. She answered:

*Fractions and powers don't play any role in the students' lives. The tasks in which powers and fractions occur are very constructed.*

This teacher probably does not feel confident when she has to include applications concerning fractions and powers in her mathematics education although she has no problems with the cognitive facets of this mathematical topic.

#### *Other Limiting Factors*

Every single interviewee referred to their deficits in PCK. They mainly named missing knowledge about the students' mathematical learning processes and the connected problems students can be confronted with. Furthermore, they complained about missing diagnostic methods to recognize these problems and in addition, about anticipating possible problems when preparing mathematics lessons. One teacher explained that it was difficult to recognize what might not be understood about her solution.

Additionally, the teachers compared teaching out-of-field in mathematics to teaching out-of-field in other subjects. Limited orientations and limited resources were observed whenever the teachers were not able to make any connection to their studied subject(s). One interviewee underlined that she was not able to draw parallels to German when teaching Mathematics as she could do when teaching English. A connection to her studied subject could potentially help her to teach out-of-field.

#### *Ambivalent Affects/Emotions*

As mentioned above we observed emotional consequences accompanying directly or indirectly articulated orientations. We can group these emotional consequences in three clusters:

### *Negative Emotions*

First, we observed negative emotions when the teachers talked about teaching mathematics or the subject mathematics itself. The teachers interviewed articulated those negative emotions by saying: “Doing math is no fun.”; “I feel uncomfortable”; “Math is not exciting at all.”; “I am overstrained.”; “I am often self-conscious.”; “Doing math is a lot of stress and is always connected to a high amount of work.”; “It is embarrassing to admit not knowing how to teach correctly”; “I’ve got a bad conscience and feel responsible for the children”; “Some colleagues fear others noticing they don’t know the curriculum of class 7.” It is interesting that none of the interviewees mentioned feeling fear when teaching as we had expected. One teacher explicitly explained: “I’ve no fear, but I’m stressed.” Either they did not admit having fear in the interview due to its public context or we have to abolish this hypothesis. Gestures and facial expressions gave no indication that they showed anxiety.

### *Positive Desirable Emotions*

Second, we witnessed emotional consequences which are positive on the one hand and desirable and helpful for mathematics education and pedagogical behavior on the other hand. The teachers interviewed expressed these positive desirable emotions by saying: “Doing math is fun.”; “I have no anxiety when doing or teaching math.”; “I think mathematics is fascinating and exciting.”; “I can really get into math.”; “I’ve got a positive gut feeling.” They give reasons for these positive emotions by stating that mathematics is helpful when solving problems (correlation to orientation type “B”), that mathematics is an instrument for exploring and researching (correlation to orientation type “C”) and that mathematics is something you can do with children (no correlation to orientation type “A”). Therefore, we name this cluster desirable as the positive emotions are justified by education-supporting orientations. We have to underline that some teachers’ positive emotions were observed more frequently when the interviewees were talking about doing mathematics with children.

### *Positive Undesirable Emotions*

In contrast, we observed positive emotions which are not helpful for mathematics education as they limit the view on what mathematics actually is. Nevertheless, the observed emotions are positive, e.g. fun. The teachers justify their positive emotions by reducing mathematics to “something being always clear”:

*Interviewee 3: "It is so much fun to teach math. It's because of ... (pause) ... Math is so structured, you've always one way and one result and you know: that's right or that's wrong. Well, therefore, I find it easy to do math and it is fun."*

We classify these positive emotions undesirable as they do not contribute to a desirable orientation of a mathematics teacher towards (doing) mathematics.

### Orientations towards Teaching Material, Textbooks and Other Support

We were able to confirm the theory that textbooks are immensely important and absolutely indispensable for teachers teaching mathematics out-of-field. Everyone whose orientation towards mathematics is not of type "A" thinks that textbooks are helpful and supportive when preparing for lessons. Some of the teachers fully absorb the contents of their textbooks and implement them in their lessons. One interviewee explained that he prepared about 70 % of his lessons with the help of the textbook. He added that he usually checked if a subject matter was in the textbook and if it was not, he would not implement it in his lessons. Some of the teachers justify the predominant use of the textbook by referring to the pre-structured subject matter, to the methods offered, and to the information about what is important for understanding a specific subject matter according to the textbook. In other words we observed that the textbook compensates the teachers' lack of CK and PCK.

Besides, some teachers referred to missing elements in their textbooks like active-learning material. More specifically, they stressed that there was "no textbook which can fully cope with the challenges of everyday school life". Some teachers mentioned the use of additional material (e.g. SINUS material, PIK AS material, worksheets, and so forth).

A teacher with an orientation of type "A" stated the opinion that textbooks are not logic for non-mathematicians, that they are hardly comprehensible, and that the problems presented are too artificial. In this case, it should be clarified if a presumably "bad" textbook has an impact on the teachers' orientation as it enhances (or creates?) the factual-pessimistic character, or if the orientation stimulates the teacher to think in this manner.

In addition, almost every interviewee stated that they got information and support from their (studied and regular-teaching) colleagues. Some explained that they compared notes with each other on demand, others reported institutionalized co-worker structures.

## Conclusions, Recommendations and Perspectives

What do the results above mean for designing in-service training programs? We aim at specifying central implications which should be considered in the wake of our first interview study:

### Mathematics – Worldview Aspects

If we want to assist out-of-field teaching mathematics teachers' orientations with a view to better mathematics education, it should be made clear that mathematics is more than a school subject and can be something relevant for children's everyday and future life. Furthermore, we have to explain that mathematics is more than solving predefined tasks. It is also a way to explore, discover and access the world – meaning that you can explore and research with mathematics. That means we have to expand the teachers' individual-occupational orientation to mathematics (in school) to a more professional one. We can assume that you have to consider orientations associated to mathematics as well as those associated to mathematics education if you want to rectify the full orientation system.

### Doing Mathematics

We have to illustrate how mathematics can provide more than one approach, one tool, or one solution for a certain problem. Furthermore, parallels to other (studied) school subjects should be worked on as a central theme so that mathematics is not seen as a closed subject without any relations to assumed non-mathematical problems.

### Emotional Consequences

Concerning emotional consequences we must be aware that positive emotions like fun are not automatically helpful for mathematical education, for example, if fun is caused by a limited orientation towards mathematics. Positive desirable emotions were observed in the context of orientations of type “B” and “C” which means that in-service training should foster such orientations. Besides, we recognized that negative emotions like fear or anxiety are difficult to analyze as those feelings seem to be repressed in non-private talks. Nevertheless, some teachers reported that they felt uncomfortable and overstrained. These teachers should be supported by institutional-cooperative structures, e.g. professional learning communities, tandems and continuous training.

### The Role of Textbooks

We were able to confirm our hypothesis concerning the role of textbooks. For out-of-field teaching teachers, textbooks supplemented by other material are the crucial source for planning and organizing mathematics education. Therefore textbooks play an important role concerning teachers' orientations as the books are a dominant medium in defining orientations associated with specific mathematical and didactical contents. Nevertheless, we should not lose sight of the (studied and 'regular'-teaching) colleagues' role as they have influence on orientations, too.

### The Role of Domain Specificity

In this inquiry we have not considered the subject profile of the teachers but it might be fruitful to contemplate if there is a difference between an out-of-field teaching mathematics teacher who studied Physics and Engineering and one who studied Social Studies and German. We have to assume that there are differences and that the domain specificity influences the orientations associated to mathematics.

### References

- Blömeke, S., Suhl, U., & Döhrmann, M. (2012). Zusammenfügen was zusammengehört: Kompetenzprofile am Ende der Lehrerbildung im internationalen Vergleich. *Zeitschrift für Pädagogik*, 58(4), 422–440.
- Bromme, R. (1992). *Der Lehrer als Experte: Zur Psychologie des professionellen Wissens*. Bern: Hans Huber.
- Bromme, R. (1994). Beyond subject matter: A psychological topology of teachers' professional knowledge. In R. Biehler, R. W. Scholz, R. Strasser & B. Winkelmann (Eds.), *Didactics of mathematics as a scientific discipline* (pp. 73–88). Dordrecht: Kluwer Academic Publishers.
- Ellis, A. (1994). *Reason and emotion in psychotherapy* (Rev. and updated.). Secaucus, NJ: Carol Pub. Group.
- Friedman, S. J. (2000). Research news and comment: How much of a problem?: A reply to Ingersoll's "The problem of underqualified teachers in American Secondary schools". *Educational Researcher*, 29, 18–20.
- Ingersoll, R. M. (1998). The Problem of Out-of-field Teaching. *Phi Delta Kappan*, 773–776.
- Ingersoll, R. M. (1998). The Problem of Underqualified Teachers in American Secondary Schools. *Educational Researcher*, 28, 26–38.

- Ingersoll, R. M. (2001). Rejoinder: Misunderstanding the problem of out-of-field teaching. *Educational Researcher*, 30, 21–22.
- Lamnek, S. (2010). *Qualitative Sozialforschung: Lehrbuch* (5th ed.). Weinheim [u.a.]: Beltz.
- Schoenfeld, A. H. (1998). Toward a theory of teaching-in-context. *Issues in Education*, 4(1), 1–94.
- Schoenfeld, A. H. (2011). *How we think: A theory of goal-oriented decision making and its educational applications*. New York: Routledge.
- Sherin, M. G., Sherin, B., & Madanes, R. (2000). Exploring diverse accounts of teacher knowledge. *The Journal of Mathematical Behavior*, 18(3), 357–375.
- Shulman, L. S. (1986). Those who understand: Knowledge growth in teaching. *Educational Researcher*, 15(2), 4–14.
- Törner, G., & Törner, A. (2012). Underqualified Math Teachers or Out-of-Field-Teaching in Mathematics - A Neglectable Field of Action? In W. Blum, R. Borromeo Ferri & K. Maaß (Eds.), *Mathematikunterricht im Kontext von Realität, Kultur und Lehrerprofessionalität. Festschrift für Gabriele Kaiser* (pp. 196–206). Wiesbaden: Vieweg+Teubner Verlag.
- Weinert, F. E., Schrader, F.-W., & Helmke, A. (1990). Unterrichtsexpertise - ein Konzept zur Verringerung der Kluft zwischen zwei theoretischen Paradigmen. In L.-M. Alisch, J. Baumert & K. Beck (Eds.), *Braunschweiger Studien zur Erziehungs- und Sozialarbeitswissenschaft. Professionswissen und Professionalisierung* (pp. 173–206). Braunschweig: Techn. Univ., Seminar für Soziologie und Sozialarbeitswiss., Abt. Sozialarbeitswiss.



## Teaching geometry interactively: communication, affect and visualisation

MELISSA RODD

m.rodd@ioe.ac.uk

Institute of Education, University of London, UK

### Abstract

*A specific challenge teachers can encounter when teaching geometry occurs when a teacher has the experience of not being able to visualise the geometrical theorem that s/he is in the middle of explaining. The paper claims that this is a phenomenon relevant to mathematics education. To better understand the phenomenon two complementary theoretical perspectives are used: (1) neuroscience which posits two principal information-processing pathways, and (2) psychoanalytic notions of defence mechanisms. An explanation for the phenomenon is offered: geometrical visualisation is processed by one of the information processing pathways and teacher communication by the other and loss of a visualisation in the classroom stimulates defences related to pedagogies for teaching geometry that makes the visualisation hard to retain. Data come from five years of teaching a 'Learning Geometry for Teaching' Masters course for in-service teachers of mathematics.*

### Keywords

*visualisation, teaching geometry, communication*

### Introduction

The subject matter of this exploratory paper is based on this phenomenon<sup>1</sup>:

A teacher, wanting to explain to students why a geometrical theorem is true, who can visualise the theorem at the beginning of an explanation, suddenly is not being able to 'see' the theorem while in conversation with the student(s).

---

<sup>1</sup> The definition of 'phenomenon' used here is "a fact or situation that is observed to exist or happen, especially one whose cause or explanation is in question" from [oxforddictionaries.com/definition/english/phenomenon](http://oxforddictionaries.com/definition/english/phenomenon) definition (1). [Accessed 10/10/12].



This has happened to me. Teachers, both novice and experienced, have told me that this has happened to them. Therefore, investigation into this phenomenon is relevant to mathematics education. This is an exploratory paper presenting results from on-going investigation.

These explorations suggest: losing visualisation when teaching happens because we take in diagrammatic-visual and classroom social-linguistic information in different ways, which are difficult to synchronise.

The paper also discusses whether a contributory factor to the marginalisation of geometry in the school curriculum is that teachers are at risk of 'losing sight of a theorem' hence avoid this sort of mathematics that is supported by visual reasoning.

A consequence of there being instances where a piece of mathematics is known but momentarily not seen (which happens in more branches of mathematics than geometry) is that 'understanding' mathematics is decoupled from 'performance' of mathematics – for teachers and students.

#### Orientating example

Consider the theorem represented by the diagram in Fig. 1. The triangles AMF and CDM are of equal area. This equality can be seen by rotating either triangle around M through a right angle (in either sense). The result of such a rotation is that equal-lengthed sides of the triangles are in a straight line, the triangles have two common vertices. The common vertex that is not on the bases' line defines the height of both triangles. Hence areas are equal.

In a classroom, a teacher typically switches from seeing (the theorem represented by the diagram) to interacting with students who 'don't get it'. At this juncture, the teacher is no longer visualising the theorem, but is poising him/herself to interpret what the students are about to offer. In the subsequent interaction, the teacher is vulnerable to losing the vision of the theorem, that is, it becomes obscure to the teacher as to how the triangles can be rotated or why the heights are the same, even while knowing that rotating a triangle through a right angle is what to do.

For a classroom teacher, suddenly experiencing this lack-of-seeing is likely to feel uncomfortable, quite possibly eliciting stress or anxiety. Of course, the way that discomfort is experienced is different: it can be, for example, mild anxiety to severe stress. The nature and intensity of the discomfort is contextual and the

teacher's perception of the discomfort may be felt only subliminally, taken in and repressed unconsciously or it may be obvious to him/her. When the lack-of-seeing happens, the ability to re-see the theorem may well be hard to achieve (why that might be is to be discussed below), so psychological defences mechanisms are stimulated. In some cases coping behaviours are stimulated by these defences and may include – giving out tracing paper, asking students to discuss, suggesting they use the sine formula, changing task – are employed rather than dwelling in the not-seeing and not communicating with students.

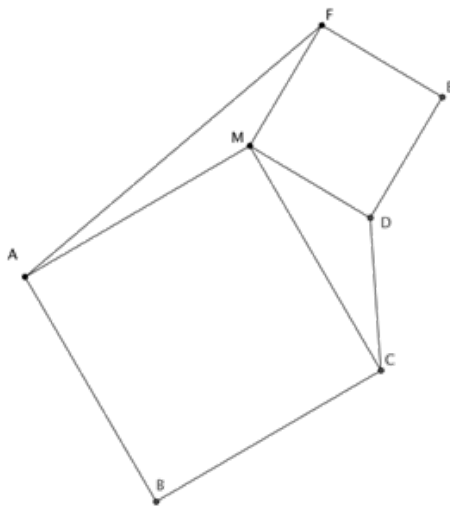

Figure 1. Theorem: the triangles are equal in area.

One of the things that we do on our in-service 'Learning Geometry for Teaching' (LG4T) course for teachers is to give time to dwell and 'permission' not to see things. For despite this triangles' areas question seeming a simple theorem with which to have a problem, our in-service teachers did have problems visualising it. Furthermore, when the diagram was on the board and I started to discuss how to 'see' the theorem represented by the diagram with students, I experienced turning back to look at the diagram and no longer seeing 'it'. 'Now you see it now you don't' was reported in Rodd (2010) from the perspective of a do-er of mathematics. In this paper, the focus is on teachers of mathematics who experience 'now you see it now you don't' while teaching.

Although reports from students and fellow teachers about similar experiences are frequently offered, I have not (yet) found related reports in the literature.

However, there are reports that relate how affect (defence mechanisms are aspects of affect) and reasoning (geometrical visualisation an aspect of mathematical reasoning) interact. For example, Gómez-Chacón (2000) catalogues the affective and cognitive responses of individuals to mathematics; while the theoretical terms used are different, Gómez-Chacón explains that the case study student Adrian likes practical work in geometry but is unable to produce symbolic reasoning. Another study, by Presmeg and Balderas-Cañas (2001), describe participants creating visual images which are personal and affect-laden (though their work was not focussed on geometry). Barrantes and Blanco (2006), studied pre-service teachers and found that they considered geometry more difficult than other subjects (though these participants' notions of geometry was more like measurement than theorem proving). So while there is acknowledgment that affect and cognition interact intimately and curiosity about this interaction, there is no one approach to develop our better understanding.

### *Teacher knowledge*

At MAVI-18 there was discussion about whether this 'lack-of-seeing' was a defect in the teacher's knowledge, specifically his/her mathematical knowledge for teaching (e.g., Rowland and Ruthven 2011). While lack of preparedness might well result in not being able to retain the vision of the theorem, there reports from knowledgeable and experienced teachers that knowing, but not seeing, happens even when well prepared. Another example, a colleague of mine offered the following, saying something like: of course I know that  $\frac{1}{4} + \frac{1}{4^2} + \frac{1}{4^3} + \dots = \frac{1}{3}$  but I experienced, while teaching a class, not being able to see that equality in the representation (in Fig 2) which was both familiar to me and I can see now.

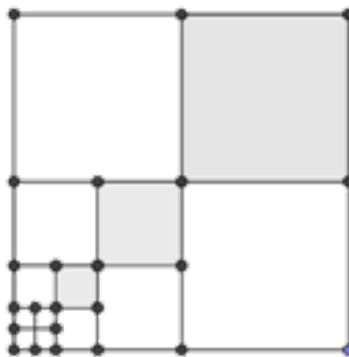

Figure 2. Visual representation of 'a quarter plus a quarter of a quarter, plus ... ad infinitum' equals a third.

Maybe reference to 'experienced and knowledgeable' is not enough! So what sort of proof would suffice? A test? Well there's the rub: the phenomenon in question is that sometimes as teachers we do not 'see' the theorem. So the test could be failed and those who want to subsume this lack of seeing as lack of teacher knowledge can say 'look s/he failed our test!'. Thus the phenomenon of 'sudden lack of seeing a theorem' is categorised as something that happens to Others, defined as the less well prepared than Ideal mathematics teachers. Of course, it is possible that for any given teacher of mathematics there is no recollection of 'not seeing a theorem'. There are two reasons for this: (1) it has genuinely not happened to that person or (2) the memory is repressed. As it has happened to a good representative sample of experienced teachers, let us move on to thinking about how this phenomenon can be investigated.

### *Tools for thought*

The tools any one of us use for investigation depend on many factors that include personal interest, experience and culture. For some time now I have been interested unconscious influences on what people do (e.g. Rodd 2011). To follow this interest, I have had to find out about psychological defence mechanisms, what they are, how they work and what manifestations can be observed. As a 'teacher trainer', I have often seen new teachers blatantly defending themselves in classrooms against adolescent students' challenges to their authority. So it is natural to ask about experienced teachers defences which may be far less obvious. So one of the tools for my investigation is the notion of 'defence mechanism'.

However, thinking in terms of 'defence mechanisms' does not give me much purchase on the relationship between visual vs. verbal thinking that explaining a theorem represented in a diagram seems to require. I found a body of work in neuroscience related to attention that is developing explanations about how attention switches; this seemed relevant as attention switches in the 'I can't see the theorem situation from visual to away from visual. The explanations from the neuroscience perspective are different from the more practice-orientated use of the word 'attention' as used, for example, by John Mason (Mason 2002). The neuroscience explains how information is processed at a physical level: *what happens when* attention switches rather than *whether* I noticed it switched. The issue of controlling attention switching is a big one and deserves more discussion than is available here.

Though there are probably other disciplines that also could be used to get insight into this phenomenon, nevertheless, with these two quite different perspectives mentioned – one more scientific, and the other more interpretative – I aim to

develop understanding as to why ‘no-see’ situations occur. Of course, these results are tentative; I am neither neuroscientist nor psychoanalyst but interested in the phenomenon because of mathematics education.

As stated above, theories that I shall use here to help thinking about why it is hard to see a geometric theorem and simultaneously speak about it with students are: (1) neuroscience: which is a discipline that investigates how information is processed by living beings; (2) psychoanalysis: which is a discipline that investigates how unconscious processes manifest themselves in peoples’ affects and behaviours. Both of these theoretical bases are enormous and reviews of these fields are not within the scope of this paper. However, using (1) and (2), I shall present and contextualise concepts or results that I am finding helpful to explain the central query of this paper which is: why is it that geometrical visualisation and talking with students are difficult to do together? The key result from neuroscience is that there are two distinct processing pathways in the brain – self-centred and other-centred; changing from visualising to communicating involves switching these attention-pathways; this switching of attention contributes to a visualisation getting lost. The key result from psychoanalysis is that all affectively responsive people defend themselves against anxieties, much of this defending is done unconsciously and these defences contribute to the orientation of attention.

The rest of the paper is organised as follows: an introduction to the theoretical lenses, application of these to pedagogy and geometry, some more data and discussion.

### Neuroscience of attention

It is well known that the brain has two distinct hemispheres, it also has other distinct regions: there are two distinct processing pathways in primate, and so in particular in human, brains located in the dorsal and ventral regions (e.g., Austin, 2008: 31, Kravitz et al. 2011). These information processing pathways are physical neural circuits that process information (Austin, *op. cit.* p57) and their respective functions have been identified as ‘ego-centric’ and ‘allo-centric’, (‘self-centred’ and ‘other-centred’) respectively. ‘Ego-centric’ and ‘allo-centric’ processing pathways are correlated with different forms of attention referred to as ‘top-down’ and ‘bottom-up’. ‘Top-down’ attention correlates with ‘where is it in relation to me?’ type queries and ‘bottom-up attention’ correlates with ‘what?’ queries and “semantic interpretation” (Austin *ibid.*, p63). These information-processing pathways are stable parts of the brain and their activity can be tracked and recorded by brain scans. There are small brain areas that are in the intersection of both pathways (*ibid.*, plates 1,2 & 3 after p168). Recent results

from the Lab for Affective Neuroscience (<http://psyphz.psych.wisc.edu/>) include the classroom-relevant result that “stress alters visual attention” (Shackman et al 2011:4) so tasks that require spatial working memory (‘seeing a theorem would count as such a task’) are hampered by stress as this disrupts the regulation of attention. ‘Stress’ in this context should not be read as a state to be denied, but recognized that some stress is common to teachers’ experience of classroom life. Furthermore, Shackman’s team found that anxiety disrupts spatial working memory more than it disrupts verbal working memory (Shackman et al, 2006).

This conception of information being processed in complementary ways may help explain the difficulty teachers of geometry can have with concurrently holding in one’s own mind a ‘vision of a theorem’ while intending to explain that vision to others (Austin, *op. cit.* p64). This is because seeing the theorem is a first person perspective event (ego-centric) but explaining it to others is a third person perspective event (allo-centric). Switching attention ‘from it (theorem) in relation to me’ to ‘it from the students’ perspective’ through communication requires a switch, in the brain-science model, of processing pathway.

Why not switch and then switch back? Yes, this would be good. And in some circumstances, with very familiar theorems, I find that I can switch from visualising the theorem (e.g., seeing a triangle rotate in Fig. 1 so that heights are equal) and attending and responding to students. But, even with familiar problems, sometimes the vision is lost. Why? Why does that switch back not happen at will? When does it/can it happen?

My hypothesis is that defence mechanisms are triggered, which makes that switching pathways more difficult and, in a conversational classroom, where mathematics is discussed and students’ understandings assessed and developed by verbal questioning and discussion, the teacher’s allo-centric pathway is more active and dominant (Shackman *et al.* 2006).

### Defence mechanisms

What are defence mechanisms? Defence mechanisms were initially mooted by Sigmund Freud as unconscious responses – ‘repression’ for example – to deal with life’s anxieties (Freud, 1896). Melanie Klein (e.g., Waddell, 1998) reformulated the idea to posit that not only do all of us defend against anxieties using defence mechanisms, whether we are aware or not, but that ‘mechanisms’ of psychological defence develop are integral to identity. Hence, defence mechanisms are essential for survival and not a priori ‘negative.’ They are called into play unconsciously to protect the ‘ego’, for example, when a student is choosing a course of study (e.g.,

Rodd, 2011) or, here, when a teacher is caught between a personal geometrical visualisation and a social and institutional need to communicate with students.

A classroom teacher will need to protect his/her ego as part of the job, no matter how favourable their environment or his/her relationships with students and mathematics. In the context of this paper, the investigation concerns what happens when an aspect of the teacher's subject knowledge<sup>2</sup> becomes suddenly unavailable: a theorem initially seen within a diagrammatic representation is not seen just at the point at which the teacher wants to draw the students towards the theorem. In the previous section, it was argued that visualising a theorem employs the ego-centric pathway and interacting with students employs the allo-centric pathway. Furthermore, I hypothesised that psychological defence mechanisms inhibit switching rapidly from one pathway to the other in such a classroom situation. Why? In a conversational classroom, relationships with students are central. The mathematics teacher's job is to draw students into mathematical practices, communities and knowledge domains. S/he does not do that by 'leaving the student' and the allo-centric processing and return to the 'ego-centric' visualising. For that course of action would be both to be observed to not know the mathematics and also to not be attending to the students, contrary to teachers' practices. Experienced teachers, who have been in these situations before, may well have prepared themselves with teaching gambits that serve to protect them in the not-seeing-the-theorem moment but position the students towards the theorem. That does not mean that it does not happen, just that their professional practice protects them.

### Pedagogy, attention and defences

Professional practices change over time and culture. In the 'olden days' a teacher of geometry might well have written out a proof of a theorem onto a board in the classroom, undisturbed by queries from students. This 'non-interactive' teaching methodology allows the clean presentation of a new piece of mathematical knowledge through a step-by-step encounter. The teacher defends, or is defended, against interruption with, or by, the practice. University lectures and academic schools would not have lasted as long as they have if this pedagogical method never worked! While a keen student may be able to use the lecture as a stimulus for study, this 'non-interactive' method does not work for all, arguably the majority, of potential learners of mathematics. Nowadays, the social dimension of learning is taken much more seriously than it might have been in the past and a present-day teacher is charged with communicating purposefully with learners who are to be motivated to turn to active engagement with the content of the

<sup>2</sup> Even though the teacher 'has' this knowledge.

mathematics curriculum. This is the current route to increase attainment and participation in many countries.

Contrasting with ‘non-interactive’, the word ‘interactive’ signals that teachers use questioning to ascertain their students’ understandings, that teachers provide tasks for their students that invite/tempt/motivate them to get active with representations of the theorem or other mathematical knowledge to be learnt, and that students engage cooperative problem solving with their peers. Furthermore, formative assessment is on-going and teachers reflect on their students’ progress as part of their planning and do not merely go on to the next theorem or topic after delivering the previous item of knowledge. Both ‘interactive’ and ‘non-interactive’ styles of practices are defensive: while the non-interactive method defends against attention being drawn away from the mathematics, arguably, the interactive method defends against attention being drawn away from the students.

On the level of the individual, a teacher of mathematics has a professional identity that includes their relationship with mathematical knowledge. So, when geometrical knowledge is challenged, for example, like the phenomenon of losing sight of a theorem (that is being discussed here), defences are evoked that protect this identity. Although cultural and personal-preferences are surely involved, it is not predictable when teacher-identity defences stimulate the top-down, ego-centric attention processing stream, (where ‘non-interactive’ practices are more comfortable) and when they stimulate the bottom-up, allo-centric attention pathway, (where interactive pedagogy is more appropriate). This is an area for further study.

## Data

Returning to the phenomenon of ‘lost sight’, to aide discussion and the understanding of two further examples are presented:

1. This example is from the Learning Geometry for Teaching (LG4T) course. The example has been chosen because it shows students’ lack of connection between visual and verbal thus it illustrates a consequence of the distinct nature of the allo- and ego- centric processing pathways.



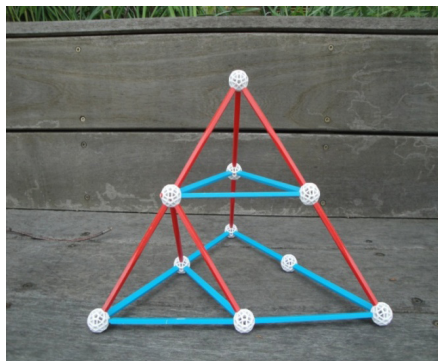

Figure 3. Apparatus used for Archimedes's demonstration of the volume of a tetrahedron formula after Burn 2009.

The LG4T students were asked to consider how to demonstrate that the volume of a tetrahedron is one third of the base area multiplied by the height by deconstructing a Zome model (Zome, webref.), see Fig. 3. This demonstration – without Zome! – is attributed to Archimedes (Burn, 2009). The model shown has edge length 2 units and the students were asked if they could visualise the edge-length-1-unit-tetrahedron ‘on the top’, which they could. Then they were asked informally about the edge-1 tetrahedron with respect to the edge-2 tetrahedron. It had been anticipated they would respond that  $2^3$  of the smaller ‘fit’ in the larger, the (1-D) enlargement factor being 2. This is a standard curriculum item in the National Curriculum in England. But what did the students (who are mathematics teachers) reply? There were 16 students most of whom called out “five” unit tetrahedral would fit in the side-2 tetrahedron with two of them offering “six” and the rest remaining silent.

What was it that the teachers of mathematics got wrong? Thinking about processing pathways, the model was a visual stimulus and visually there are four edge-1 tetrahedra visible ‘and one – or maybe two – in the middle’ [thanks to Cathy Smith for this suggestion]. Their answers were quick response to a visual stimulus based on their perspective and they did not integrate their semantic knowledge of the volume enlargement formula. The stimulus of a model of a cube edge-1 enlarged to edge-2 was used effectively to make the link so that they were able to analyse their visual response and modify their answer.

2. This is an example of another teacher communicating his lost vision within explaining mode. This example has been chosen because the teacher becomes

aware of the problem and communicates what is happening to the students. This teacher was unable to see the visual relationship even while knowing and understanding what that relationship is and how it works. Also he was able to acknowledge that this phenomenon of 'lost vision' happens.

A dynamic geometry diagram (DGD) is on the board which is being used to in a novel proof of the circle theorem 'angle at the centre is twice the angle at circumference' (Küchemann 2003). Initially, the angle under consideration is set at 41degrees and a configuration is pointed out to the students didactically. The DGD is manipulated so that the angle under consideration is changed. And then the vision is lost which is communicated to the students by the utterance "I don't know. There is a way, I can't see it at the moment." Returning the DGD to 41degrees, the vision is regained and the students are told "don't worry if you don't see it. I have to work my way through every time. Momentarily I see it – which is lovely – then it fades."

#### Discussion and conclusion

Why does the phenomenon of seeing a theorem then losing the vision happen?

It happens because of the different ways the visual (ego-centric) and the communicative (allo-centric) are processed in the primate (therefore, human) brain. Unconscious defence mechanisms militate against a teacher regaining his/her vision in a communication-orientated environment (like a contemporary classroom).

Is there a way to help teachers get back their vision of the theorem they were teaching?

Not routinely. Yet if the teacher is able to return to processing ego-centrally the vision may pop back, as in example 2 where the DGD was manipulated back to the initial position, the visualisation of the theorem popped back.

In mathematics folklore, the mathematician G.H. Hardy, is attributed to have said in a lecture "This is obvious." Then paused and said "Hmm, is it really obvious?" After another pause he left the room to consider the point, returning 20 minutes later with the verdict: "Yes, I was right, it is obvious." This illustrates what an uninhibited person might do to get back the ego-centric processing.

Is there a way for this lack-of-teacher seeing to be a learning opportunity for students?

Possibly. If the teacher is able to observe this lack of seeing in him/herself, and is able to reveal this lack of seeing to the students in the class and then explain that this phenomenon does occur and not to be too worried about it, as in example 2, perhaps the students too will be reassured that visualisation can be lost then re-found. The Hardy scenario has become a story because it is 'not done'. Yet possibly, if an atmosphere of introspective concentration and be established within a classroom, the teacher, as well as students, may have the opportunity to regain the 'obviousness'. This was possible with adult teachers of mathematics engaged in a Masters course. However, the challenge would be greater with adolescent students in compulsory education.

Does this phenomenon relate to the marginalisation (at least, in England, if not elsewhere too) of geometry in the school curriculum?

This is a conjecture. As human beings we withdraw from discomfort (stress, anxiety, pain etc.) and approach comfort and pleasure. Being in a position where the vision of the theorem has been lost is an uncomfortable place particularly when in the midst of one's students and it would be understandable if it was avoided in the future. Hence the teaching the geometry that is centred around theorem visualisation and justification is at risk of not being relished by teachers and so not being enjoyed by students. In this way, defences distance teachers and students from these theorem-visualising geometric practices.

This paper has been exploring the phenomenon of a teacher not retaining a geometrical visualisation as s/he is in the process of explaining the theorem represented by the diagram that holds that visualisation. Inasmuch as this 'losing the vision' is an event there will be associated emotion (Damasio, 2003). Psychological theory that attends to subjectivity (rather than just observable behaviours) posits defence mechanisms are stimulated by such an emotion. These defence mechanisms unconsciously influence subsequent behaviours. And the pain of not being able to access mathematical knowledge with which teacher identity is associated – as is the scenario of this paper – will lead to withdrawing from practices that risk this exposure. The complementary problem of finding it difficult to talk about how one is seeing a theorem, which is also relevant to the practices that are comfortable for a given teacher. These observations contribute to understanding why geometry can be marginalised in the curriculum and lead to understanding more about the teacher as s/he teaches, in particular, to explain why geometrical visualisation is difficult for classroom teachers.

There is resistance to the idea that a person – teacher or student – can 'know' something but not 'perform' that knowledge at any point in time. This is because,

so much modern life is based on 'evidence' from assessment into which there is considerable investment. A consequence accepting the central claim of this paper (that there are instances when a mathematical theorem is known but, a representation of that theorem is not 'seen'), is that 'understanding' mathematics is decoupled from 'performance' of mathematics.

## References

- Austin, J. H. (2008). *Selfless Insight: Zen and the meditative transformation of consciousness*. Cambridge MA: The MIT Press.
- Barrantes, M., & Blanco, L. J. (2006). A study of prospective primary teachers' conceptions of teaching and learning school geometry. *Journal of Mathematics Teacher Education* 9:411–436.
- Burn, B. (2009) [atm.org.uk/events/conferences/conference2009.html](http://atm.org.uk/events/conferences/conference2009.html) unpublished workshop presentation.
- Damasio, A. (2003). *Looking for Spinoza: Joy, Sorrow, and the Feeling Brain*. San Diego CA. Harcourt.
- Freud, S. (1896). Further remarks on the neuro-psychoses of defence, In J. Strachey (Ed.) *The standard edition of the complete psychological works of Sigmund Freud (1953-1974)*. (vol. 3. 159-185) London: Hogarth Press.
- Gómez-Chacón I. M. (2000). Affective influences in the knowledge of mathematics. *Educational Studies in Mathematics*, 43, 149-168.
- Howson, G. (1982). *A History of Mathematics Education in England*. Cambridge: Cambridge University Press.
- Kravitz, D. J., Saleem, K. S., Baker, C. I., & Mishkin, M. (2011). A new neural framework for visuospatial processing. *Nature Reviews Neuroscience* 12, 217-230.
- Küchemann, D. (2003). Angle in a circle: taking a point for a walk. *Mathematics in School*, Vol. (2) March 2003.
- Mason, J. (2002). *Researching your own practice: the discipline of noticing*. UK: Routledge.
- Presmeg, N. C., & Balderas-Cañas, P. E. (2001). Visualization and Affect in Nonroutine Problem Solving. *Mathematical Thinking and Learning*. 3:4, 289 – 313.
- Rodd, M. (2010). Geometrical Visualisation – epistemic and emotional. *For the Learning of Mathematics* 30(3) 29-35.
- Rodd, M. (2011). Participation in undergraduate mathematics: choices and defences. In K. Kislenko (Ed.), *Current State Of Research On Mathematical Beliefs XVI*, 237-254. Institute of Mathematics and Natural Sciences, Tallinn University, Tallinn, Estonia.

- Rowland, T., & Ruthven, K. (Eds.) (2011). *Mathematical Knowledge in Teaching*. UK: Springer. Series: Mathematics Education Library, Vol. 50.
- Shackman, A., Sarinopoulos, I., Maxwell, J., Pizzagalli, D., Lavric, A., & Davidson, R. (2006). Anxiety Selectively Disrupts Visuospatial Working Memory. *Emotion*, Vol. 6, No. 1, 40–61.
- Shackman, A., Maxwell, J., McMenemy, B., Greischar, L., & Davidson, R. (2011). Stress Potentiates Early and Attenuates Late Stages of Visual Processing *The Journal of Neuroscience*, 31(3):1156 –1161.
- Waddell, M. (1998). *Inside lives: Psychoanalysis and growth of personality*. London: Routledge.
- Zome (2008). Geometry Tool. <http://www.zometool.com/> [Accessed 13/5/12].

# Secondary school teachers' statistical knowledge for teaching and espoused beliefs on teaching and learning of variability-related concepts

ORLANDO GONZÁLEZ

ogonzalez@hiroshima-u.ac.jp  
Hiroshima University, Japan

## Abstract

*The importance of statistics education in secondary school has been emphasized in numerous mathematics curriculum reforms recently carried out in many countries, being noticeable that variability may arise within all the statistical contents included in such curricula. Hence, the role played by the statistical knowledge for teaching, beliefs on teaching and learning of variability-related concepts, and conceptions of variability held by teachers is crucial to satisfactorily achieve the mathematics curriculum. This article introduces a novel conceptual framework for investigating the aforementioned traits, and a survey questionnaire based on such framework. A case study will also be presented, in order to illustrate how the proposed model might be used in practice.*

## Keywords

*statistical knowledge for teaching, secondary teachers' beliefs, conceptions of variability*

## Introduction

Aiming towards ensuring statistical literacy for all students before leaving compulsory education, recent curricular reforms in many countries have brought a number of statistical topics into the mathematics curriculum (e.g., NCTM, 2000), especially in secondary school, in which fundamental ideas in statistics – such as data, distribution, representation, association, probability, sampling and inference – are being taught. Thence the importance of the role played by teachers in teaching such fundamental ideas, which may be either the only statistics program taken by future users of statistics, or the knowledge base for those continuing studies at tertiary level.

It is noticeable that variability may arise in many ways in those statistical contents found in the secondary school mathematics curriculum. Variability – a property of an statistical object which accounts for its propensity to vary or change—is considered a fundamental concept in statistics (cf. Shaughnessy, 2007; Pfannkuch & Ben-Zvi, 2011); and its acknowledgement and understanding are regarded as essential skills for statistical literacy, reasoning, and thinking (cf. Sánchez, da Silva & Coutinho, 2011). According to Gattuso and Ottaviani (2011, p.122), “[t]o be part of a modern society in a competent and critical way requires citizens to ... understand the variability, dispersion, and heterogeneity which cause uncertainty in interpreting, in making decisions, and in facing risks”, and teachers are in charge of fostering such understanding in their students. Thus, teachers’ subject matter and pedagogical content knowledge in relation to variability-related contents, their beliefs on teaching and learning of such contents, and their conceptions of variability, are anticipated to affect the performance and quality of teachers’ work, and hence their students’ learning.

Despite all the arguments above, there is a notable scarcity of studies on the aforementioned areas (Shaughnessy, 2007). Hence, it is by no means surprising the urgent calls for increasing research on such areas recently made for many concerned researchers (e.g., Sánchez et al., 2011, p.219; Pierce & Chick, 2011, p.160). Accordingly, the purpose of this paper is to respond to such calls for research by proposing a hypothetical descriptive conceptualization of *statistical knowledge for teaching*—henceforth SKT, the knowledge, skills and habits of mind needed to carry out the work of teaching statistics in a way that supports student learning and achievement—, aiming to get a clearer picture about the SKT, statistics-related espoused beliefs and conceptions of variability held by secondary school mathematics teachers.

## The MKT Model

Ball, Thames and Phelps (2008) developed the notion of *mathematical knowledge for teaching* – henceforth MKT – focusing on both what teachers do as they teach mathematics, and what knowledge and skills teachers need in order to effectively teach mathematics. This model describes MKT as being made up of two domains – *subject matter knowledge* (SMK) and *pedagogical content knowledge* (PCK – each of them structured in a tripartite form, as depicted in Figure 1.

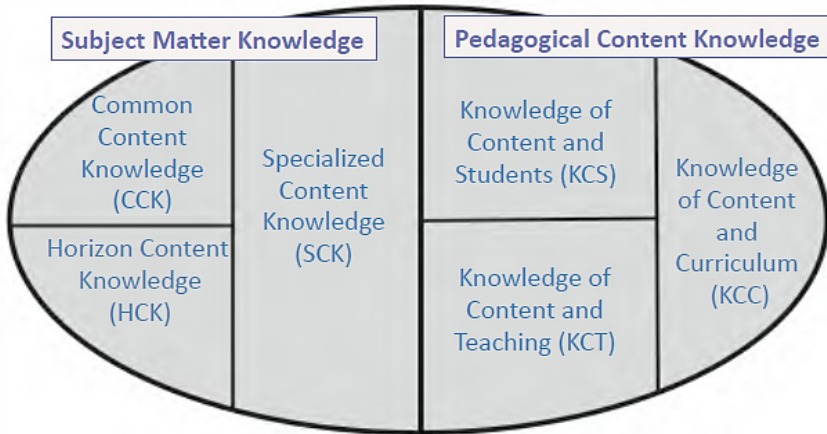

Figure 1. Domains of MKT, according to Ball et al. (2008).

According to Ball et al. (2008), SMK is divided into *common content knowledge* (CCK), *specialized content knowledge* (SCK), and *horizon content knowledge* (HCK), while PCK is divided into *knowledge of content and students* (KCS), *knowledge of content and teaching* (KCT), and *knowledge of content and curriculum* (KCC) (the interested reader may refer to the original article by Ball et al. (2008) for a detailed discussion of the MKT model).

Through this framework, Ball and her colleagues made, among others, a clear distinction between SMK and PCK, a refinement of the aspects of teachers' knowledge identified by previous researches, and significant progress in identifying the relationship between teacher knowledge and student achievement in mathematics (cf. Petrou & Goulding, 2011, pp.15-16). However, as highlighted by some researchers (e.g., Petrou & Goulding, 2011, p.16), this model does not acknowledge the role of beliefs in teachers' practices, which could be a drawback since beliefs are often regarded in the literature as important factors affecting the work of teaching (cf. Philipp, 2007).

### A New Conceptualization of SKT

Due to the considerable overlap and cooperation between mathematics and statistics, as well as between the structure of mathematics education and statistics education (cf. Gattuso & Ottaviani, 2011), it is by no means surprising that almost all the few conceptualizations of SKT proposed to date have somehow



assimilated the aforementioned model for MKT (cf. Groth, 2007; Burgess, 2011; Noll, 2011). However, neither of them takes into account the role of beliefs in teachers' professional practice, nor considers all the six components in the MKT model, which could result in an inadequate picture of teachers' preparedness to teach statistical contents.

The purpose of this section is to address these gaps in the research on statistics education by proposing a novel conceptualization of SKT, attempting to set out from the literature some critical components related to the knowledge entailed in teaching variability-related contents effectively. Many components that were thought to be potential indicators of SKT were identified and considered, and the following conjectures were raised:

- (a) *The proposed model of SKT should be closely tied to a model of MKT:* On the basis that statistical contents are often taught as part of secondary school mathematics curriculum by mathematics teachers, and due to the common grounds shared by mathematics and statistics, it is anticipated that a model of SKT should be closely tied to one of MKT. Thus, the author argues that the six constructs necessary for having a solid MKT identified by Ball et al. (2008) will serve as a useful starting point to hypothesize what knowledge might be needed to effectively teach statistics.
- (b) *Some components in the MKT model used must be redefined to meet the case of teaching statistics:* Although the common grounds shared by mathematics and statistics, the two disciplines are different in several ways (for an in-depth discussion of these differences, see Gattuso & Ottaviani, 2011). Hence, in order to acknowledge such differences and meet the requirements specific to the teaching of statistics, herein CCK will be seen as statistical literacy, since the acquisition of the latter is expected from all students after completing school education (Gal, 2004; Pfannkuch & Ben-Zvi, 2011), in a same way than CCK is expected from any well-educated adult.
- (c) *In order to conceptualize SKT, teachers' beliefs about statistics, its teaching and learning must be considered:* The vital role of beliefs – defined as “psychologically held understandings, premises, or prepositions about the world that are thought to be true” (Philipp, 2007, p.259 – in every aspect of teachers' work has been well articulated in the literature (for a summary of such researches, see Philipp, 2007), with only few studies addressing the particular case of statistics education (e.g., Pierce & Chick, 2011). Moreover, beliefs are identified by Gal (2004) as one of the dispositional elements of statistical literacy. Hence,

teachers' beliefs about statistics, its teaching and learning are going to be regarded as fundamental in this model of SKT.

- (d) *Tasks designed to elicit teachers' conceptions of variability will be helpful to provide indicators to assess SKT:* Conceptions – the set of internal representations and corresponding associations that a particular concept evokes in a person, often explained as “conscious beliefs”—have been proven to influence teachers' teaching approaches, as hence their students' approaches to learning (cf. Trigwell, Prosser & Waterhouse, 1999). Moreover, conceptions represent knowledge and beliefs working in tandem (Knuth, 2002). Thus, gaining insight into teachers' conceptions of variability is regarded as necessary in the proposed model for SKT.

Based on the four conjectures previously outlined, a comprehensive framework for conceptualizing SKT in the context of teaching variability-related contents was developed, aiming to gather qualitative information about the level of SKT held by secondary school mathematics teachers (see Table 1).

*Table 1. Set of indicators proposed to assess SKT.*

---

*A: Indicators associated to CCK:*

1. Is the teacher able to give an appropriate and correct answer to the given task?
2. Does the teacher consistently identify and acknowledge variability and correctly interpret its meaning in the context of the given task?

*B: Indicators associated to SCK:*

1. Does the teacher show evidence of ability to determine the accuracy of common and non-standard arguments, methods and solutions that could be provided on a single question/task by students (especially while recognizing whether a student's answer is right or not)?
2. Does the teacher show evidence of ability to analyze right and wrong solutions that could be given by students, by providing explanations about what reasoning and/or mathematical/statistical steps likely produced such responses, and why, in a clear, accurate and appropriate way?

*C: Indicators associated to HCK:*

1. Does the teacher show evidence of having ability to identify whether a student comment or response is mathematically/statistically interesting or significant?
  2. Is the teacher able to identify the mathematically/statistically significant notions that underlie and overlie the statistical ideas involved in the given task?
-

*D: Indicators associated to KCS:*

1. Is the teacher able to anticipate students' common responses, difficulties and misconceptions on the given task?
2. Does the teacher show evidence of knowing the most likely reasons for students' responses, misconceptions and difficulties in relation to the statistical ideas involved in the given task?

*E: Indicators associated to KCT:*

1. In design of teaching, does the teacher show evidence of knowing what tasks, activities and strategies could be used to set up a productive whole-class discussion aimed at developing students' understanding of the key statistical ideas involved in the given task, instead of focusing just in computation methods or general calculation techniques?
2. Does the teacher show evidence of knowing how to sequence such tasks, activities and strategies, in order to develop students' understanding of the key statistical ideas involved in the given task?

*F: Indicators associated to KCC:*

1. Does the teacher show evidence of knowing at what grade levels and content areas students are typically taught about the statistical ideas involved in the given task?
  2. Does the designed lesson (or series of lessons) show evidence of teachers' understanding and support of the educational goals and the intentions of the official curriculum documents in relation to the teaching of the statistical contents present in the given problem, as well as statistics in general?
- 

## Assessing Teachers' SKT through a Questionnaire Survey

### About the Survey Instrument

A pen-and-paper instrument, comprised by a seven-question task addressing variability-related concepts present in the secondary school mathematics curriculum, was designed in terms of the indicators outlined above. The purpose of this instrument is to gather information about the eight critical components related to the knowledge entailed in teaching variability-related contents effectively identified by this study – namely the six knowledge components in the model for MKT developed by Ball et al. (2008); teachers' beliefs about statistics, its teaching and learning; and teachers' conceptions of variability. Each question in the instrument was developed based on those used in previous studies with similar aims reported in the literature (e.g., Ball et al., 2008; Isoda & González, 2012), which were adapted to reflect the context of the item and the specific objectives of the present model of SKT.

## Profile of the Survey Item

Table 2. Knowledge components of SKT elicited by each of the questions posed in Item 1.

<i>Elicited Knowledge Component of SKT</i>	<i>Associated Indicator of SKT</i>	<i>Question</i>
Statistical Literacy (as CCK)	A1	(a)
	A2	(a)
Specialized Content Knowledge (SCK)	B1	(c)
	B2	(c)
Horizon Content Knowledge (HCK)	C1	(e)
	C2	(b)
Knowledge of Content and Students (KCS)	D1	(d)
	D2	(d)
Knowledge of Content and Teaching (KCT)	E1	(g)
	E2	(g)
Knowledge of Content and Curriculum (KCC)	F1	(f)
	F2	(g)

Item 1 (see Figure 2) is the seven-question task developed to be surveyed in this study. The task upon which this item is based on is an adaptation of the one used by Garfield, delMas and Chance (1999), which has been reported in the literature as an effective means to investigate teachers' conceptions and understanding of variability in the context of histograms and comparing distributions (e.g., Makar & Confrey, 2004; González, 2011; Isoda & González, 2012). Regarding this adaptation, modifications to the original task were done in order to facilitate the calculations required to answer. Furthermore, the resultant task was enriched with seven questions, in order to elicit all the facets of SKT identified by this framework. A mapping between the cognitive components of SKT that would be brought out by each question in Item 1, as well as the indicators identified by this framework associated to such components, can be appreciated in Table 2.

About the Survey Implementation and the Data to be Analyzed

**ITEM 1**

Please, read carefully the following task and answer the questions below:

*Choosing the distribution with more variability.* Look at the histograms of the following two distributions:

Score	Frequency
2	6
3	3
4	9
5	14
6	4
7	7
8	5

Score	Frequency
1	1
2	2
3	6
4	9
5	11
6	14
7	11
8	9
9	6
10	2

Which distribution (A or B) do you think has more variability? Briefly describe why you think this.

- Answer this task in as many different ways as you can. Please, be sure to show every step of your solution process.
- What are the important ideas and concepts that students might use to answer this task?
- Suppose that, after posing this task to your students, three of them come up with the following answers:
  - Student 1:* “Distribution A has more variability because it’s not symmetrical.”
  - Student 2:* “Distribution A ranges from 3 to 14, while Distribution B ranges from 1 to 14. Then, Distribution B has more variability.”
  - Student 3:* “The bars in Distribution A are clumped closer to the central bar than they are in Distribution B. Then, Distribution B has more variability.”

Dealing with each student separately, please comment briefly on each of these answers, focusing on whether the answer is correct or not, why you think so, and what reasoning might have led students to produce each answer.

- Suppose you pose this task to your students. What are the most likely responses (correct and incorrect), misconceptions and difficulties you would expect from them? Briefly explain why you think so. (Regarding to the most likely answers that you might get from the students, please do not include those mentioned in part (c).)
- Mathematically/statistically speaking, is any of the answers given by the students interesting or significant? If yes, briefly explain why and on what aspects. (Please, focus your response on whether there is a significant mathematical/statistical insight in the student’s answer, and whether there are forthcoming contents in future classroom subjects overlying or related to the notions/concepts being said or implied in such answer.)
- Briefly describe how the important ideas and concepts involved in the solving process of the given task are addressed in official curriculum documents across the different grade levels of schooling.
- Suppose you want to plan a lesson (or a series of lessons) to introduce the meaning of variability in the context of the given problem to your students. Briefly describe as many instructional strategies, activities and/or tasks as you can think of that would be appropriate to use for this purpose, and sequence them accordingly, explaining why you chose to put them in such a particular order.

Figure 2. Item 1 – “Choosing the distribution with more variability” task.

In a first stage of this study, the survey instrument was sent via postal mail to four public secondary schools in two Japanese prefectures during July 2012. Herein, the written responses to Questions (a) and (g) on Item 1, given by five senior high school teachers from two of the schools participating in this study, will be reported and preliminarily analyzed, in order to exemplify how the proposed framework is put into practice, and then warrant particular claims made in this article. The respondents were between 28 and 56 years old, they had between one and thirty-four years of teaching experience – with three of them with at least 13 – and were the first group of teachers that voluntarily and anonymously answered and mailed back to the author the survey booklets.

### Results and Findings regarding Question (a)

Giving an appropriate answer to Question (a) in Item 1 requires from teachers, among others things, to exhibit knowledge and understanding of several fundamental concepts and ideas (e.g., variability, arithmetic mean and frequency distribution tables), as well as ability to connect and represent them. For this reason, answers to Question (a) are anticipated to elicit evidence of the indicators associated to CCK outlined in Table 1 – namely A1 and A2.

Four out of five teachers answered this question, with two of them – Teachers 2 and 3 – using three different approaches: Teacher 2 answered by comparing the range, variance and interquartile range of both distributions; while Teacher 3 answered by comparing the range, the shape, and the mean absolute difference from the mean of both distributions. Teachers 1 and 5 answered using only one approach: Teacher 1 by comparing the ranges, and Teacher 5 by comparing the largest data span from the mean in both distributions.

It is quite surprising that all these teachers made computation errors in every approach involving calculations. Among them, a recurrent one was using the class marks for computing the range and the largest data span from the mean. Moreover, it is also noticeable the fact that one teacher – Teacher 3 – mistakenly used the shape and the histograms' bar arrangement to answer, which is a common misconception in this kind of problems (cf. Isoda & González, 2012).

Regarding the conceptions of variability held by the respondents, there is empirical evidence in the literature that they will emerge from teachers' answering approach to Question (a) (cf. González, 2011; Isoda & González, 2012). In the present study, the eight types of conceptions of variability identified by Shaughnessy (2007, pp.984-985) will be used to classify those distinguished within teachers' answers. Then, the answer given by Teacher 1 indicates he holds the first conception of variability identified by

Shaughnessy (2007) – “Variability in particular values, including extremes or outliers” –, since this teacher’s attention was merely focused on the variability of particular data values in the given histograms, namely the extremes of both distributions. The answers given by Teacher 2 and Teacher 3 indicate they hold the eighth conception of variability identified by Shaughnessy (2007) – “Variation as distribution” –, since they were able to use multiple theoretical properties of the histograms to calculate – although mistakenly – the measures of variation associated to each distribution in order to make their decision. In the case of Teacher 5, his answer indicates he holds the fifth conception of variability identified by Shaughnessy (2007) – “Variability as distance or difference from some fixed point” –, since this teacher was able to visually identify the bar representing the mean class in each histogram, and from there consider – although mistakenly – the variation of the endpoint values from the mean. Contrarily to the teachers holding the conception “Variation as distribution”, Teachers 1 and 5 do not exhibit an aggregate view of data and distribution, since they were predominantly concerned with the variability of particular data points at a time, rather than with the variability of an entire data distribution from a center (cf. Shaughnessy, 2007, p.985).

### Results and Findings regarding Question (g)

The purpose of this question is to elicit evidence of the indicators associated to KCT outlined in Table 1 – namely E1 and E2. In order to make a judgment about the occurrence of each of these indicators in teachers’ answers to Question (g), such answers were scrutinized in the search for evidence of the characteristics of effective classroom activities to promote students’ understanding of variability compiled by Garfield and Ben-Zvi (2008).

All the five teachers answered this question. In relation to Indicator E1, using the characteristics identified by Garfield and Ben-Zvi (2008) as guide it is reasonable to say that the answers given by Teacher 1, Teacher 2 and Teacher 5 (cf. Figure 3) are the ones that seem to exhibit a higher level of knowledge about the features of effective activities that promote students’ understanding of variability, since in these answers are suggested tasks involving comparisons of data sets, as well as activities promoting a whole-class discussion on how measures of central tendency and variation are revealed in graphical representations of data (Garfield & Ben-Zvi, 2008, pp. 207-209). It is noteworthy how Teacher 2 devises a task comparing distributions as a chance to address different measures of variation simultaneously (*ibid.*, pp.207-208), chance that is missed by the other teachers (e.g., Teacher 1 devises the same kind of task as a chance to address merely the concepts of mean and range). It is quite surprising that none of the five respondents mapped the characteristics of the given histograms to alternate graphical

Teacher 1	Teacher 2
<p><i>Two teams are asked to make five 10-gram pieces of sushi (in practice, students could prepare them with clay). Team A prepared sushi pieces of 11, 12, 10, 9 and 8 grams, being the mean 10 grams. On the other hand, Team B prepared pieces of 5, 6, 10, 14 and 15 grams, being the mean 10 grams. Which team made sushi better?</i></p> <p>This task provides a setting in which only the mean cannot be considered while the two datasets are compared. In that way, students have to focus on the minimum and maximum values in each dataset. By doing so, I think they will experience personally the need of thinking about variability</p>	<p><b>Task:</b> 「Among 2 distributions, which one do you think has more variability?」</p> <p><b>Activities:</b></p> <ol style="list-style-type: none"> <li>① Check different ways (range, variance, standard deviation, interquartile range) for examining variability.</li> <li>② Place students in groups, asking to each group to use only one of the methods in ① to discuss about what things could be told about the variability of the given distributions.</li> <li>③ Each group will share with the rest of the classroom what they considered in ②.</li> <li>④ Depending on the method used, and while checking different considerations, think about how to look at variability.</li> </ol> <p>Students will experience personally the need of using several methods and finding out the appropriate one in order to consider data trends.</p>
Teacher 3	Teacher 4
<ol style="list-style-type: none"> <li>1.To make students think about which of 2 given histograms, A and B, has more variability.</li> <li>2.To make students think about whether they can make their decision based only on the sample size.</li> <li>3.To judge the variability using the variance.</li> <li>4.Practice problems.</li> </ol>	<p>In mathematics there are a large number of approaches in many directions concerning “variability”:</p> <ul style="list-style-type: none"> <li>– Introduction of the formulas related to variability.</li> <li>– Studying variability through the use of computer technology.</li> </ul> <p>Based on the aforementioned approaches, bring up for discussion various topics in society and the corporate world, such as product development, among others, as well as their connections with practical applications.</p>
Teacher 5	
<ul style="list-style-type: none"> <li>– Give 2 histograms, A and B.</li> <li>– To make students think about in which histogram the variability is larger, and to make them expose about what they think.</li> </ul> <p>...At this stage, a detailed explanation about “variability” has not yet been provided.</p> <ul style="list-style-type: none"> <li>– After their presentations, explain about “variability”, and make students think again about which histogram has more variability.</li> <li>– Explain, among other things, different terms besides “variability”, provide different histograms, and practice.</li> </ul>	

Figure 3. Answers to Question (g) given by five Japanese senior high school teachers.



representations – such as ogives or boxplots –, which are present in the Japanese senior high school mathematics curriculum. Garfield and Ben-Zvi (2008, p.207) point out that a task in which is possible to make or link more than one representation of the given data not only promotes students' understanding of variability, but also leads to a better interpretation of the statistical ideas involved.

Regarding Indicator E2, and using again the characteristics identified by Garfield and Ben-Zvi (2008) as guide, it is reasonable to say that the answers given by Teacher 2 and Teacher 5 are the ones evidencing more knowledge on how to sequence activities and strategies intended to promote students' understanding of variability. As suggested by Garfield and Ben-Zvi (2008, pp.135-137), both teachers planned to start their lessons by presenting students with some simple data, in order to then interpret it. However, Teacher 5 is at an even higher level, since he explicitly states that variability should be described and compared informally at first, and then formally, through measures of variation (cf. *ibid.*, p.208). It is noteworthy the explicit connections to daily life contexts expressed in the answers given by Teacher 1 and Teacher 4, as well as the suggestion of conducting real experiments in the classroom made by Teacher 1, both characteristics of effective activities aiming to promote students' understanding of variability that have been highlighted in the literature by several statistics educators (e.g., *ibid.*, p.328; Shaughnessy, 2007).

Regarding teachers' beliefs about statistics teaching and learning, such beliefs can be identified through examining the features of lesson plans made by teachers – such as the tasks selected to consider a particular statistical idea, and the types of instructional strategies chosen by the teachers – as the limited research on this topic suggests (e.g., Pierce & Chick, 2011, pp.156-159). Based on this, teachers' beliefs – in this case espoused beliefs, since they are identified from a survey in which teachers envision themselves behaving in their imagined classroom environments, and they may act in a totally different fashion during their teaching practice – are anticipated to be identified by respondents' answers to Question (g) in Item 1, in which teachers' personal approaches to teach specific statistical contents would arise.

In relation to the beliefs about the nature of statistics held by the surveyed teachers, the answers given by four of them – Teachers 1, 2, 3 and 5 – provide evidence that they see statistics as a process of inquiry; that is, as a means of answering questions and solving problems. Teachers holding this belief typically agree with ideas such as “in statistics many things can be discovered and tried out by oneself” or “statistical problems can be solved correctly in many ways”. The answer given by Teacher 4 provides evidence that he sees statistics as a set

of rules and procedures. Moreover, the answers given by Teachers 1, 2 and 5 provide evidence that they see statistics learning as being active learning, since they planned lessons in which students are encouraged to both find their own solutions to statistical problems and engage with and interpret data, while fostering the development of statistical discourse and argumentation in the classroom through class discussion, rather than promoting the memorization of formulas and procedures (cf. Pierce & Chick, 2011, p.159). The answers given by Teachers 3 and 4 give evidence that they see statistics learning as a teacher-centered individual work. It is noteworthy that only one of the surveyed teachers – Teacher 1 – seems to believe that teaching of statistics could be accomplished through conducting real experiments in the classroom, in order to develop students' abilities to address real stochastic problems.

## Conclusions

Since variability may arise within all the statistical contents included in the secondary school mathematics curriculum, teachers must efficiently grapple with this fundamental statistical idea. In order to qualitatively scrutinize the knowledge and skills entailed in effectively teaching variability-related contents held by our teachers, a novel conceptual framework for SKT was developed and implemented through a case study, in which the answers given by five Japanese senior high school mathematics teachers to two particular questions in a survey instrument – Questions (a) and (g) – were preliminary analyzed.

From the responses given to Question (a), it is clear the existence of some answer tendencies; for example, to mistakenly use the class marks to calculate particular measures of variation. Also, one teacher was found holding a common misconception in this kind of problems. Despite of this, evidence of three teachers in this group exhibiting an aggregate view of data is noteworthy.

Some of the characteristics identified in teachers' answers to Question (g) are consistent with those of effective classroom activities promoting students' understanding of variability made by the specialists. However, it is noticeable the lack of consideration by almost all the respondents of an explicit daily-life context in their answers, which is vital to internalize in the students that statistics helps to solve everyday problems. Moreover, from the answers to Question (g) it is evident that three teachers believe that statistics learning should be achieved by students' active involvement, instead of a teacher-centered way. The other two teachers seem to see statistics learning as a teacher-centered individual work.

The fact that teachers' answers showed, among others, a lack of knowledge about how to relate the given task to different data representations, and due to the importance of making an appropriate interpretation of variability to both effectively teach variability-related contents and achieve the aims of mathematics education regarding statistics, courses in which Japanese secondary mathematics teachers could learn more about describing and representing variability, using variability to make comparisons, and so on, may be required.

## References

- Ball, D. L., Thames, M., & Phelps, G. (2008). Content knowledge for teaching: What makes it special? *Journal of Teacher Education*, 59(5), 389–407.
- Burgess, T. A. (2011). Teacher knowledge of and for statistical investigations. In C. Batanero, G. Burrill & C. Reading (Eds.), *Teaching Statistics in School Mathematics* (pp. 259–270). New York: Springer.
- Gal, I. (2004). Statistical literacy: Meanings, components, responsibilities. In D. Ben-Zvi & J. Garfield (Eds.), *The Challenge of Developing Statistical Literacy, Reasoning and Thinking* (pp. 47–78). Dordrecht: Kluwer.
- Garfield, J., & Ben-Zvi, D. (2008). *Developing students' statistical reasoning*. New York: Springer.
- Garfield, J., delMas, R., & Chance, B. (1999). *Tools for Teaching and Assessing Statistical Inference*. Retrieved from [http://www.tc.umn.edu/~delma001/stat\\_tools/](http://www.tc.umn.edu/~delma001/stat_tools/)
- Gattuso, L., & Ottaviani, M. (2011). Complementing mathematical thinking and statistical thinking in school mathematics. In C. Batanero, G. Burrill & C. Reading (Eds.), *Teaching Statistics in School Mathematics* (pp. 121–132). New York: Springer.
- González, O. (2011). *Survey on Japanese elementary, middle and high school teachers' statistical literacy: Focusing on variability* (Unpublished master's thesis). University of Tsukuba, Tsukuba, Japan.
- Groth, R. E. (2007). Toward a conceptualization of statistical knowledge for teaching. *Journal for Research in Mathematics Education*, 38, 427–437.
- Isoda, M., & González, O. (2012). Survey on elementary, junior and high school teachers' statistical literacy: The need for teacher training in variability (in Japanese). *Journal of Science Education in Japan*, 36(1), 61–76.
- Knuth, E. (2002). Teachers' conceptions of proof in the context of secondary school mathematics. *Journal of Mathematics Teacher Education*, 5(1), 61–88.
- Makar, K. M., & Confrey, J. (2004). Secondary teachers' reasoning about comparing two groups. In D. Ben-Zvi & J. Garfield (Eds.), *The Challenges of Developing Statistical Literacy, Reasoning, and Thinking* (pp. 327–352). Dordrecht: Kluwer.
- National Council of Teachers of Mathematics (NCTM) (2000). *Principles and Standards for School Mathematics*. Reston, VA: NCTM.

- Noll, J. A. (2011). Graduate teaching assistants' statistical content knowledge of sampling. *Statistics Education Research Journal*, 10(2), 48–74.
- Petrou, M., & Goulding, M. (2011). Conceptualising teachers' mathematical knowledge in teaching. In T. Rowland & K. Ruthven (Eds.), *Mathematical Knowledge in Teaching* (pp. 9-25). New York: Springer.
- Pfannkuch, M., & Ben-Zvi, D. (2011). Developing teachers' statistical thinking. C. Batanero, G. Burrill & C. Reading (Eds.), *Teaching Statistics in School Mathematics* (pp. 323–333). New York: Springer.
- Philipp, R. A. (2007). Mathematics teachers' beliefs and affect. In F. K. Lester (Ed.), *Second Handbook of Research on Mathematics Teaching and Learning* (pp. 257–315). Charlotte, NC: IAP.
- Pierce, R., & Chick, H. (2011). Teachers' beliefs about statistics education. In C. Batanero, G. Burrill & C. Reading (Eds.), *Teaching Statistics in School Mathematics* (pp. 151–162). New York: Springer.
- Sánchez, E., da Silva, C. B., & Coutinho, C. (2011). Teachers' understanding of variation. In C. Batanero, G. Burrill & C. Reading (Eds.), *Teaching Statistics in School Mathematics* (pp. 211–221). New York: Springer.
- Shaughnessy, J. M. (2007). Research on statistics' reasoning and learning. In F. K. Lester, Jr. (Ed.), *Second Handbook of Research on Mathematics Teaching and Learning* (pp. 957–1009). Reston, VA: NCTM.
- Trigwell, K., Prosser, M., & Waterhouse, F. (1999). Relations between teachers' approaches to teaching and students' approaches to learning. *Higher Education*, 37, 57–70.



# Mathematics lessons as stories: linking semiotics and views of mathematics

CHIARA ANDRÀ<sup>1</sup> AND NATHALIE SINCLAIR<sup>2</sup>

chiara.andra@gmail.com

<sup>1,2</sup> University of Torino, Italy;

<sup>1</sup> Laurentian University, Canada;

<sup>2</sup> Simon Fraser University, Canada

## Abstract

*Stemming from the embodied mind paradigm and focusing on teachers' use of speech, gestures and diagrams during a traditional mathematics lesson, we outline different teaching styles in terms of the modality of communication, the invitations to notice and the nature of the story being told. The modality refers to the use of gestures and diagrams, and it is understood in semiotic terms, while the story concerns the lesson, its content, and the way the content is presented to the students. The noticing can be seen as a by-product of both: through both modality and story, we see different ways of drawing attention. Our goal is to better understand the various ways in which teachers draw students' attention, which will provide a foundation on which to better understand students' experience of a mathematics lesson.*

## Keywords

*views of mathematics and its teaching, narratology, semiotics, noticing*

## Introduction

Many mathematics classes, especially at the tertiary level, feature the teacher lecturing from the front of the classroom. We have become interested in the images of mathematics that emerge in such lessons, which feature not only talk, but also gestures, diagrams and other extra-linguistic modes of communicating about mathematical objects.

A semiotic approach to the teaching/learning processes in mathematics can be considered as a privileged point of view, given the special ontological status of mathematical objects: in fact, they are not accessible in a direct way, but they are intrinsically mediated by signs (see for example: Duval, 1995; Arzarello, 2006). Asserting that mathematical objects can be accessed only by

means of *representations*, Duval (1995) came to state that cognitive acts such as understanding a concept are not possible without the coming into being of a relation between the sign, the representation, and the mathematical object the representation refers to, that is: the signified. Researchers have developed different semiotic approaches, which stem from different epistemological perspectives. Duval's approach, which is structural (signs are organized in systems of signs) and functional (sign systems fulfill transformational, discursive and metadiscursive functions), allows a semiotic analysis of the teaching process. There is, in fact, a growing interest in the way that multiple semiotic means (gestures, diagrams, symbols, speech, tone of voice, etc.) are used in mathematics teaching and learning (c.f. Arzarello; 2006; Arzarello *et al.*, 2009). While most of this research has been carried out in the context of classrooms featuring groupwork and problem-solving tasks, it can be applied also to the traditional lecture. Indeed, Andrà (2010a) combined this perspective with a Communication Sciences approach, to investigate different styles of teacher communication in lecture-based classrooms.

Using the metaphor of “performance,” which suits well the lecture-style lessons we want to study, we developed a way of interpreting a mathematics lesson as a story being told by the teacher for the students. This approach gives rise to constructs that can be used to understanding how students might experience the lesson, including what their attention is drawn to, what they perceive as important, and how they record the lesson through their notes.

### Story, modalities and invitations to notice

Following, Bal's (2009) narratologic perspective, we can distinguish the *mathematical teacher's story* from the *mathematical students' fabulae*. The latter corresponds to the students' interpretations of the lesson. The former can be viewed as the teacher's temporal revelation of the fabula. Further, the *text* can be seen as the style the teacher uses to present the mathematical content, which focuses attention on two fundamental semiotic unities: the speech-gesture unity and the speech-written sign one. These unities correspond to Andrà's (2010b) teaching modalities: the *body-modality*, when the communication takes place mainly through the teacher's gestures, and the *blackboard-modality*, when the teacher communicates mainly through the written signs. A teacher's style can be described in terms of the amount of use of each modality and the rhythm of shifting between them.

In order to better characterize the notion of *text* as the particular presentation of the teacher's mathematical *story*, we can attend to the way the teacher attempts

to draw attention to certain parts of the story: underlining a symbol, repeating a definition, saying that something will be on the test. We call them *invitations to notice*, according to Mason's (2010) discipline of noticing. We claim that the teacher's style of communication affects student noticing and also gives rise to different views of mathematics and its teaching. We conjecture that the blackboard-modality occasions more recording-noticing than the body-modality, regardless of the teacher's intention.

The teacher's *story* can also be analysed in terms of its components: its characters, setting, action, plot, and moral. Mathematical objects, in fact, can be considered the *mathematical characters* of a story (Dietiker, 2011). They can play a central or a peripheral role, have multiple names, and have properties that can be introduced and developed gradually.

The *setting* is the space where characters are placed. Sometimes the setting is not obvious, as it refers to underlying assumptions and/or axioms. For example, the statement 'one plus one equals zero' invites one to appreciate the mod-2 setting in which the addition is taking place. The setting may also involve different semiotic registers (Duval, 1995), such as algebra or the Cartesian coordinate system. Duval's (1995) approach stems from a realistic view point that considers mathematical objects *a priori inaccessible* ideal objects. Since mathematical objects are inaccessible entities, the theory pivots around the notion of *semiotic registers* and the coordination of semiotic systems through *treatment and conversion* transformations. A semiotic register is characterized by a set of *elementary signs*, a set of *rules* for the *production* and the *transformation* of signs and an underlying *meaning structure* deriving from the relationship between the signs within the system. Mathematical objects, which cannot be referred to directly, are recognized as invariant entities that bind different semiotic representations. Duval identifies the specific cognitive functioning to mathematics with the coordination of a variety of semiotic systems. He identifies meaning with the *couple (sign-object)*, i.e. a relationship between a sign and the object it represents. The sign becomes a rich structure that condenses both the semiotic representation, and the way the semiotic expression offers the object in relation to the underlying meaning of the semiotic structure. Meaning therefore has a twofold dimension: (i) the way a semiotic representation offers the object; (ii) the reference to the inaccessible mathematical object.

The *action* is that which the actor performs. In mathematical stories, an action can be seen—according to Duval (1995)—as a transformation of a representation into another one, within the same semiotic system (treatment), or in another semiotic system (conversion). The result of an action can be a change in an object or in a



setting, or both. According to Duval (1995), in fact, meaning making processes and learning in mathematics require to handle different semiotic structures networked through semiotic transformations without losing the reference to the inaccessible, invariant mathematical object. According to Dietiker (2011), we see that, unlike in literary stories, mathematical ones can change actions into objects (through reification).

The *moral* can be seen as the intended message of the lesson. The *plot* is the sequence of actions and it involves the *shaping* of the story, which is linked to its *aesthetic effects*: for instance, the rhythm and the frequency of the story (Bal, 2009) may affect the students' focusing on the areas of emphasis of the story and foster his anticipative acts. Arzarello's (2006) semiotic bundle allows a semiotic analysis of the teacher's use of beats, i.e. non propositional gestures that underlie and support the narrative, the changes in the tone of his voice, the areas in the classroom he positions himself, and so on (Andrà, 2010b). Some moves might displace attention away from what the teacher wants to communicate: for example, repeating the name of a character often (which might seem innocuous) may lead the students to think that the actual name is important, or more important than its properties. Other moves may induce the students to believe that the setting is unimportant.

## Methodology

The aim of this paper is to take a narratologic and a semiotic lens in order to study and possibly characterize different views of mathematics. For this purpose, we analyze the first 6 minutes of two one-hour university lectures on probability and statistics: L on the Gaussian distribution and R on the interval estimate of the mean. We chose these two for the diverging style, despite the surface similarities (topic, lecture-based, no student involvement). These lectures are part of a larger research study investigating the effect of teachers' gestures, drawings and extra-linguistic forms of expression on students' emotional and cognitive responses.

In previous researches (Andrà, 2010a), we observed that the first phase of a lesson is the most interesting for a semiotic analysis: the teacher is tying with his audience and he performs a lot of gestures as well as written signs. That is why we considered the very beginning of the lesson in this research.

To analyze the two lessons, we took a narratologic lens in which we attended to the following elements: the mathematical characters that are told; their (explicit or hidden) setting, understood in terms of the semiotic register (Duval, 1995); the actions, by analyzing the verbs that are used by the teacher; the moral. As regards

the setting, we have paid special attention to the graphical and the symbolic registers, as they are written on the blackboard. Together with the blackboard modality (Andrà, 2010b), we also considered the body modality, which is meant as the *text* of the story, namely the style the teacher adopts in order to tell it.

## The examples of L and R

At the beginning of his lecture, L leans on the blackboard with his hands behind his back, talking slowly and recalling the mathematical characters that were present in previous lectures. He reminds students of the “box” (some kind of “black box” that transforms a number into a probability) that “spits out numbers”:

[1] L: [...] and we have tried to characterize different boxes, making in the end the probability distribution which emerges from the various possible outcomes of this extraction. I also recall that two substantially different kinds of things had arisen: on one hand, the



boxes that spit out integer numbers, for example the binomial distribution or the Poisson distribution, whose results make sense only with integer numbers, on the other hand the continuous distribution like the normal.

[2] L: one of the problems that emerged was that you have a normal distribution, which usually is not the standard one, it has a certain mean and a certain variance or standard deviation, doesn't it? [he stands up, looks at the blackboard and then at the students, and with his hands performs a gesture that recalls the bell curve]

L's posture and tone of voice can be read in terms of the plot of the story: by talking slowly, he allows the students to grasp more information. At the same time, his humble posture and his low-pitched talk suggest that he is not telling a central part of the story. He is performing in body-modality, with gestures accompanying his speech. In 1, he introduces the characters of the boxes and the probability distributions. Until this point, there is no action. In 2, L introduces the *crisis*—that is, the moment in the story that gives rise to actions—by posing this problem: it is not possible to know all the normal probability distributions given any mean and any variance. The change in L's posture—he now stands straight and uses his right hands—can be read as underlining his message, and

his anticipatory gesture shaping the bell curve focuses the attention to what is relevant, while also creating suspense.

[3] L: *Hence, you have [draws a bell curve on the blackboard's top-left – Fig. 1a] a certain distribution, which gives you a certain probability, say it is a curve such that the area under the curve tells you how much it is probable that a number would come out in that particular interval [draws two points on the x axis, and two vertical lines to outline the area – Fig. 1b].*

[4] L: *Ok? Then, the name of this curve is Gauss' bell [on the side of the graph he writes  $N(x; \mu, \sigma)$ ]. And it has a well defined distribution, which is [writes the formula without saying it – Fig. 1c]*

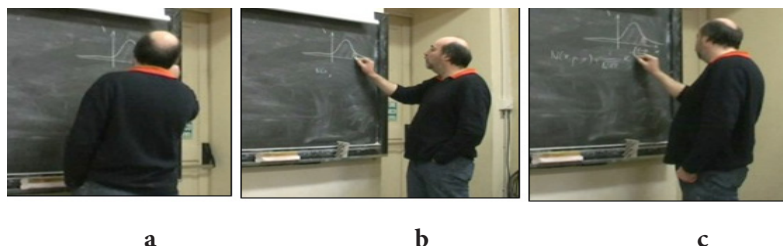

Figure 1. L introduces the main character of the story.

In 3, L changes the setting of the story: from the numerical semiotic register, he shifts to the graphical one. In this new setting the probability of an event is described as an area under the curve. In 3, L explains the conversion from one register to the other. To do so, he changes modality from body to blackboard, thus also changing the rhythm of the talk. In 4, L passes to the symbolic register. In 3 and 4, L faces the blackboard (adopting the same perspective as the students), and writes/draws and talks at the same time. The rhythm is influenced by the writing act, and it is slower, but he is still offering two different modes of information (the verbal and the drawn). He describes the main character of the story:

[5] L: *This one is called the normal distribution, or the Gaussian, and they are synonymous in quotation marks, obviously it is called the Gaussian by Gauss [readjusts the brackets of the formula with the chalk].*

[6] L: *Well, you remember that you are in this situation and then, in order to solve problems of this kind, what is the probability of obtaining a given, a certain interval? Since you do not have a table for any mu and sigma.*

[7] L: *You have a standard way of taking this problem and of transforming it in a problem with the zeta [with his left hand, L covers an arch in the air, close to the blackboard – Fig. 2a], namely you make a variable transformation and you obtain a certain distribution that is called the standard Gaussian, the standard normal distribution [draws the standard curve on the left of the other graph – Fig. 2b]*



Figure 2. Transformation from general to standard normal distributions.

In 5, L repeatedly names the Gaussian character. In 6, he repeats the problem, this time introducing a part of the setting: the distribution table. While no action is performed in the story during 5 and 6, an important one emerges in 7: that of transforming the problem (anticipated by L's gesture in Fig. 2a). Then, he introduces the standard normal distribution character within the setting of the graphic register.

[8] L: *That, instead, has these features: it is centred on zero and it has standard deviation equal to 1.*

[9] L: *That is, it is like this [he writes the formula without saying it out loud]*

[10] L: *Note that if you set mu equal to 0 and sigma equal to 1 here, you obtain that one [he draws an arrow from the first to the second graph – Fig. 3a]. And on this side you have all the tables you need to solve the problem.*

[11] L: *The passage from one to another is given in this way [he draws arrows and conversion formulas – Fig. 3b]. Hence, note that these transformations are each other's inverse: if you know  $x$ , you compute zeta, if you know zeta, you compute  $x$  without problems.*

In 8, the setting is still in the graphic register, while in 9 there is a shift to the symbolic one. But L remains in blackboard-modality. After 8 and 9's focus on characters, 10 features the action of passing from one distribution to another, and from one setting to another (from the algebraic register of  $\mu$  and  $\sigma$ , to the numeric one). This also changes the actions that can be taken, since one can now use the distribution tables to evaluate the formula. The distribution table is part of the setting: it involves the numerical register. While the numeric register often signals the end of the story (and its ultimate goal), L returns to this semiotic register in 11, where he specifies the actions of transforming.

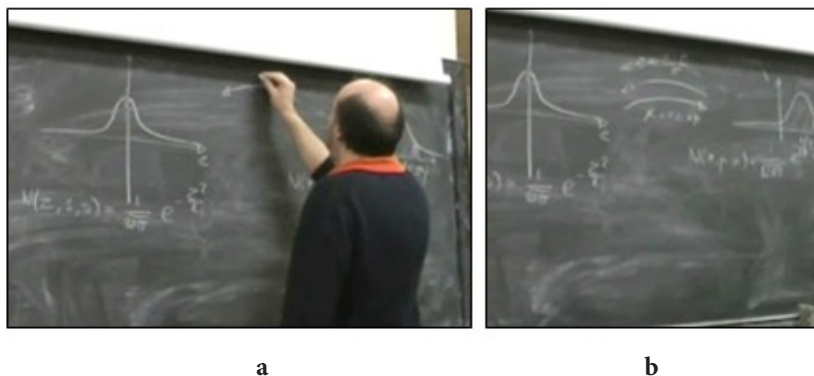

Figure 3. Transformation from general to standard normal distributions (continue).

This sequence ends with the moral:

[12] L: *Well, I have given you this as a matter of fact. The experiment of today is: I want to see if I am able to explain it, okay?*

The purpose of the lecture is, mathematically speaking, to prove whether it is possible to transform a generic normal distribution into a standard one. In other words, the focus (at 06:19) is on 'why' the transformation can be done. 12 thus appears as somewhat surprising, since everything before unfolded as a gradual elaboration of characters and action during which the need to and possibility of transforming becomes evident. What is there to explain?

A different choice is made by R. She begins her lecture by providing the moral of the story: that is, the interval estimate. The 'why?' cannot be immediately recognized, as in L's case, since R does not yet have the tools necessary to elaborate the moral. In fact, she needs to introduce the characters of the story, as well as

their actions and the setting, in order to get to the moral. But, in contrast to L, R names it at the very beginning of the story, and then proceeds to endow it with meaning as she goes along. In blackboard-modality, she begins by writing on the top-right of the blackboard the title of the lesson and then underlining it.

[1] R: *Why interval estimate? Until now we have taken into account some objects, the estimators [writes  $T = T(X_1, \dots, X_n)$ ], function of the sample [she writes v.a. (in Italian “random variable”) left of T], and we have used them to get point estimates of the parameters of interest.*

[2] R: *Namely, these objects, which are random variables, occur [she writes  $T(x_1, \dots, x_n)$ ] in particular samples that one finds at hand [she touches  $T(x_1, \dots, x_n)$  with her index finger], taken the sample that is given, one will compute these objects, the estimators, on the numeric [the tone of the voice is louder when she says ‘numeric’] sample that will be given, hence on the realization, and one will find a value of theta hat [writes  $\theta$ ] that is small, hence a number at that point, which is a point estimate of the parameter T of interest in our problem.*

In 1, R recalls the previous episode of the story, in which the estimators were the characters (she uses the symbolic register on the blackboard), and the moral was the point estimate. In 2, she firstly specifies better the estimators, calling them random variables. In 1 R has anticipated this feature, since she has written on the blackboard “v.a.” (“random variable” in Italian), before mentioning them as random variables. Then R introduces another character, the sample, using a symbolic register on the blackboard (Fig. 4d). She provides the setting where this character ‘lives’ and what may be done with it. In the end of 2, R connects the character ‘estimator’ to the character ‘sample,’ specifying their relationship.

In terms of the rhythm, when she is not writing on the blackboard, R moves toward the area behind the desk, and talks from this position. Since she writes frequently in this part of the lecture, the effect is a back-and-forth movement from the desk to the first blackboard, which results in a rhythmic interplay between written and spoken worlds. She uses the symbolic register on the blackboard, and the natural language one in speech. Whereas L uses the blackboard mainly for the graphic register, R uses it mainly to write formulas.

After this sequence, R imagines that another sample would be taken, and underlines what changes and what remains the same in the story. This helps to better describe the character ‘sample,’ since it clarifies which are its unavoidable features. After this, R focuses her attention again on the moral:

[3] R: *If I compute [this object] on different samples, it gives me different numbers, and then I would give, when I give this number [Figure 4a], namely this point estimate, I would give also an interval [Figure 4c] of values between which I am confident enough that the parameter would be. Namely, giving also an idea of the variability [she shapes a bell curve with her hands – Figure 4c] of the numeric value that I give. A person has a sample of numbers, I give back another number [Figure 4d], which is exposed to variability, and I would give an information about how much this number can vary.*

[4] R: *Hence, given the theta hat, namely given the point estimate, I would try to give an interval of type  $L_1, L_2$  [she writes on second blackboard – Figure 4e] and say that this interval [she writes  $1-\alpha$ ], with a good probability, confidence (now we'll see why this distinction between probability and confidence), my value of the population parameter is contained there, hence I would say more.*

[5] R: *Until now, we have always considered [she draws an arrow under  $\theta$ ] theta hat, namely an estimate; now we would give more, namely an interval, and say that this interval we are sure enough, confident enough, there is a high probability, that our parameter will be exactly inside it. It is additional information. And it will be computed based on the distribution of our estimator, hence to the variability we have considered.*

In 3, R performs in body-modality: the point estimate is shaped in front of her, with her fingers crossed (Fig. 4a); the interval estimate is something that she can hold with her hands (Fig. 4b). We note that there is a similarity between the gesture corresponding to the 'interval estimate' and the one corresponding to the 'confidence' (Fig. 4c). The former is a result of a horizontal opening of her hands from figure 3a to figure 3b; the latter is the last part of a vertical gesture which shapes the bell curve. Despite the different origin, we interpret the similarity of R's gestures in terms of anticipating the link between 'confidence' and 'probability,' as she makes explicit in 4. In terms of the point interval, R uses two different gestures (Fig. 4a and 4e) to indicate the same character. They communicate two different features of the character: in Fig. 4a, the point estimate is something that is a point, in contrast to the interval of Fig. 4b; in Fig. 4c, the point estimate is something that is given, through certain computations, as the outcome.

In 4, she introduces the character of the confidence interval. On the blackboard she writes its property,  $1-\alpha$ , without specifying any detail. Again, the symbolic register is anticipating a concept that will be given later in the natural language.





Figure 4. R is introducing the confidence interval.

In 5, R repeats the concepts she introduced earlier: all the characters come up again in the story, implicitly or explicitly (the estimator, the sample, the point estimate, the interval). And the relationships among them are given. In this part, R is not gesturing nor writing. The rhythm of the plot seems to slow down: after the intensive blackboard-modality, after the intensive body-modality, R repeats again the concepts, without the help of the written signs or gestures. One has the sense that the action is finished; the curtain could fall. Indeed, after 5, R goes on to provide an example in which she computes the point estimate of the mean. After the example, she returns to the problem of finding a confidence interval, performing in blackboard-modality to further specify the features of the new character in this lesson. The written signs go along with the speech, instead of playing an anticipating role. The setting shifts between the general, symbolic register and the particular, numerical one.

### What can be learned from this analysis

We have analysed L's and R's lessons *as mathematical stories*, that is, as the temporal revelation of the fabula they present to the students. Although examining (and comparing) different mathematical stories is interesting in itself, our ultimate goal is relating the differences in the characteristics of the stories with teachers' different views of mathematics and its teaching. We do not speak in terms of beliefs since we are not trying to impute intention to the teacher. Indeed, with Roth (2011), we see the teacher (and the students) as passive to the act of telling a story. And our point of view is much more that of the student, watching the teacher and seeing what he says/does. We cannot see the students, so we have very little insight into how the teacher's decisions are affected (if at all) by the students' gaze, actions or movements. This can be seen as a limitation of the study, since we are assuming that the teacher has very little perception of whether her "audience" is attending the lecture: this is not the case at least at lower levels of education, given the more inter-acting features of the kind of lessons usually primary school teachers enact. In a sense, we can consider widening the range



of application of this analysis. However, we will argue that this explorative study may open a window on new ways of dealing with mathematics, its teaching, and view of mathematics.

In terms of the *text* of the story, we observed that L begins his lesson in body-modality and then continues in blackboard-modality—employing mainly a graphical register; R begins in blackboard-modality, until she gets to the moral, when she shifts to body-modality, and then returns to blackboard-modality using a mainly symbolic register. In terms of noticing, there is also an issue of permanency: what that is written on the blackboard remains (and this is also one of the reasons why the students often copy what is written on the blackboard); what that is said through gestures and the body flies away together with the speech. Mason would say that what is written is recorded (at least by the teacher), or marked by the majority of students, or it is expected to be so; in contrast, what is said by the body may not be noticed in the same way. However, even that which is written on the blackboard may not be noticed by the students, or noticed in a way that is not the one that is intended by the teacher. At any rate, we hypothesize that there is an unstated agreement that what is on the blackboard is identified by the students as that which the teacher finds worth noticing. We claim that this behavior cannot be ascribed solely to the didactical contract, otherwise students would notice (and write down) only that which is on the blackboard (and all that which is on the blackboard). Since this is not the case, we infer that that the students' noticing is affected also by their relationship with mathematics. In other words, it is affected by their experience of the story.

This relationship is shaped by the teacher and his view of mathematics and its teaching: for example, if we consider the rhythm of the lesson, we observe that both L and R mark the importance of the characters by returning to them repeatedly. L re-draws and refines parts of the graphs, while R draws circles and arrows with respect to the symbols indicating the relevant character. The modality affects the way the story is experienced because the students experience those characters that are described orally and with gestures differently than they experience characters described through diagrams and written words. Hence, the modality changes the mathematical object, so that the modality chosen to tell the story is not merely an external medium, but constitutes the story itself, the characters, and the way they are received by the students. But, further, the modality changes the teacher: when she uses her body, she puts herself in the role of a mediator between the discipline and the students. When she uses the blackboard, the blackboard takes on this role of the mediator, and she is a human being that—together with the students—looks at the disciplinary agency expressed on it. Hence, the teacher is changed by the modality.

We have analyzed when and how the *mathematical characters* of a story have been introduced and characterized, as well as their *setting* (mainly in terms of Duval's semiotic registers) and the actions that can be made on them (e.g. computing, transforming). We have also considered the *aesthetic* of the mathematical story. In particular, we analyzed the teacher's modes of creating suspense. In the case of L, we observed that he brings the students to the object of the lecture gradually and smoothly. R, instead, declares immediately the main focus of the story, but she often anticipates parts of her story with written signs or gestures: there is a temporal mismatch between her speech and her gestures/writings. Hence, for L there is a global suspense, while for R there are many local instants of suspense. Moreover, L's blackboard is annotated, refined and expanded around the central object of the graph, while R's blackboard is linear at the beginning, and becomes full of arrows and circles during the lesson. Following Netz's (2009) distinction of style, we would say that L is Archimedean, in that the elements of his lecture feature mosaic structure and narrative surprise. R's linear presentation, instead, is more in accordance with contemporary mathematics, where the general structure of the argument is signposted so that the learner knows how different tools will be used.

The modality of the teacher affects the experience of the students and, more specifically, the body-modality invites thinking while blackboard-modality invites scribbling (writing notes). The "invitation" that can be seen in terms of Rotman's (1988) schema, which distinguishes between imperatives that tell a reader to be a "thinker" (e.g. explain) and imperatives that prompt the reader to be a mere "scribbler" (e.g. draw). Only, instead of being about imperatives, it's about the modality: because the teacher is explaining, the invitation is to think, but when the teacher is writing, the invitation is to do. Similarly, Barthes (1975) distinguishes between readily texts, which deliver to the receiver a fixed, pre-determined reading, and writerly texts. Readerly texts, with their dependence on an omniscient narrator and adherence to the unities of time and place, create an illusion of order and significance. In contrast, writerly texts force the reader to produce a meaning or set of meanings that are inevitably other than final or "authorized" – they are personal and provisional, not universal and absolute.

Barthes' work draws our attention to the distinction between thinking of learning as passive consumption or as active production of meaning. It is also natural to wonder how well this comparison holds up in our context of mathematics teaching. Certainly, educators' pleas for multiple representations, multiple solutions and discovery learning can all be seen as efforts to render mathematics learning a little more writerly. But there's more to the notion of writerly that can provoke our thoughts on the role of story in mathematics and mathematics

education. Sinclair (2005) found that even writerly texts can be prescriptive—so they may provide only an illusion of emancipation, but Barthes develops the picture that our experiences of text depend not only on *what we read*, but on *how we read*. In a sense, we surmise that even in the context of a traditional lecture-style lesson, where the students are supposedly passively receiving a large quantity of information, the aesthetic aspects of the delivery may affect not only *what they record*, but also *how they record*. In this respect, we are interested in analysing students' notes to see whether different teaching styles can be related to invitations to think. This could be seen in the ways students go beyond simply copying down the information as they make choices in, for example, reframing/rephrasing the content, adding comments and question marks, establishing what is crucial and what is peripheral.

## References

- Andrà, C. (2010a). Gestures and styles of communication: are they intertwined? In *Proceedings of the Sixth Conference of the European society for Research in Mathematics Education*, Lyon, FR; (DOI: <http://ife.ens-lyon.fr/publications/edition-electronique/cerme6/wg10-04-andra.pdf>)
- Andrà, C. (2010b). Teaching styles in the classroom: how do students perceive them?, In *Proceedings of the 34<sup>th</sup> Conference PME*. Belo Horizonte, BR (Vol. 2, pp. 145-152).
- Arzarello, F. (2006). Semiosis as a multimodal process. *Relime, Número especial*, 267-299.
- Arzarello, F., Paola, D., Robutti, O., & Sabena, C. (2009). Gestures as semiotic resources in the mathematics classroom. *Educational Studies in Mathematics*. 70(2), 91-95.
- Bal (2009). *Narratology: Introduction to the theory of narrative*. (C. Van Boheemen, Tran.) (3rd ed.). Toronto: University of Toronto Press.
- Barthes, R. (1975). *The Pleasure of the Text*. New York: Hill and Wang.
- Dietiker, L. (2011). The stories of textbooks: Exploring sequences in mathematics curriculum. Presented at the *2011 Annual Pre-session of the National Council of Teachers of Mathematics*, Indianapolis, IN.
- Duval, R. (1995). *Sémiosis et pensée humaine. Registres sémiotiques et apprentissages intellectuels*. [Semiotics and human thinking. Semiotic registers and intellectual learning]. Berne: Peter Lang.
- Mason, J. (2010). Noticing: roots and braches. In M. G. Sherin, V. R. Jacobs & R. A. Philipp (Eds.), *Mathematics teacher noticing* (pp. 35-50). Routledge, New York and London.
- Netz, R. (2009). *Ludic proof: Greek mathematics and the Alexandrian aesthetic*. New York, NY: Cambridge University Press.

- Roth, W-M. (2011). *Passibility: At the limits of the constructivist metaphor*. New York, NY: Springer.
- Rotman, B. (1988). Toward a semiotics of mathematics. *Semiotica*, 72 (1/2), 1-35.
- Sinclair, N. (2005). Chorus, colour, and contrariness in school mathematics. *THEN: Journal*, 1(1). Retrieved from <http://thenjournal.org/feature/80/>.