

Robust Control of Single-Mast Stacker Cranes

Sándor Hajdu*, Péter Gáspár**

* Department of Mechanical Engineering, University of Debrecen
Ótmető u. 2-4, H-4028 Debrecen, Hungary, e-mail: hajdusandor@eng.unideb.hu

** Systems and Control Laboratory, Institute for Computer Science and Control,
Hungarian Academy of Sciences

Kende u. 13-17, H-1111 Budapest, Hungary, e-mail: gaspar.peter@sztaki.mta.hu

Abstract: The stacker cranes in automated storage/retrieval systems (AS/RS) of warehouses often have very high dynamical loads. These dynamical loads may generate harmful mast vibrations in the frame structure of stacker cranes which can reduce the stability and positioning accuracy of these machines. The aim of this paper is to develop controller design methods which have proper reference signal tracking and mast-vibration attenuation properties. First, the dynamic modeling of single-mast stacker cranes by means of multibody modeling approach is summarized. Based on this modeling technique a \mathcal{H}_∞ and a robust control design method are proposed for achieving the appointed purposes. The analyses of the controlled systems are carried out by time domain simulations.

Keywords: stacker crane; modeling uncertainties; robust control; multi-body model

1 Introduction

One of the most important materials handling machines in automated storage/retrieval systems (AS/RS) of warehouses is the stacker crane. These machineries realize the storage/retrieval operation into/from the rack structure of warehouse. The stacker crane frame structures are often subjected to very high dynamical loads due to the inertial forces in the acceleration and braking phases of moving cycles. These dynamical loads generate undesirable, low frequency and high amplitude mast-vibrations in the frame structure. These high amplitude mast-vibrations reduce the positioning accuracy and the stability of the stacker cranes. In extreme cases, the massive oscillations may damage the frame structure of these machines.

Because of the above-mentioned reasons, the harmful mast-oscillations must be reduced. This can be performed for example by means of controlling the traveling motion (towards the aisle of the warehouse) of the stacker crane. In this paper, some controller designing techniques (based on \mathcal{H}_∞ approach) are developed

which can reduce the harmful mast-vibrations. In [2] and [4] authors introduce motion control techniques to attenuate the mast-vibration of stacker cranes. However, in these works the effect of lifted load position and magnitude on the dynamical properties of the structure is neglected during the controller design. The main purpose of this work is to develop a controller design method which takes varying lifted load position and magnitude into account and at the same time having proper reference signal tracking and mast-vibration attenuation properties.

In this paper, the so-called multibody modeling technique is applied to the dynamic modeling of single-mast stacker cranes. For more information about this modeling approach see the following books: [1, 3]. Some further examples of dynamic modeling of stacker cranes by multibody models can be found in [17] and [18]. Concerning the mathematical models of electric drive systems see, e.g. [13-16]

For control design purposes, \mathcal{H}_∞ [5-8] and robust control [19] approaches are applied. The presented control design methods in this paper are based on the results of our previous work, see in [10]. The main contribution of this paper is the robust \mathcal{H}_∞ position controller which can handle the model uncertainties due to varying lifted load conditions. First, the concept of \mathcal{H}_∞ control is presented by means of a standard \mathcal{H}_∞ control method (the so-called mixed-sensitivity loop shaping). After that, a more sophisticated method is developed for the robust \mathcal{H}_∞ position control of stacker cranes. The method for the determination of weighting function parameters in robust control design is also proposed.

The structure of the paper is as follows. In Section 2 the background of dynamic modeling of single-mast stacker cranes is summarized. The state space representation of the model is also introduced. In Section 3 the mixed-sensitivity loop shaping control method for the positioning control of stacker cranes is presented. Section 4 proposes a robust control method which aim is the fast and vibration-free positioning control of stacker cranes in the presence of model uncertainties.

2 Modeling Aspects of Single-Mast Stacker Cranes

In this section the modeling considerations necessary to the control design are briefly summarized. Before the control design a suitable dynamic model must be generated, as mentioned in the introduction, for this purpose the multibody modeling approach is chosen. In this multibody model the continuous sections of the mast are approximated by rigid elements having lumped masses, its center points (i.e. nodes). These elements are interconnected by elastic hinges. More details of this multibody model, as well as the main parameters of investigated stacker crane, are presented in [9-11].

One of the most important steps of dynamic modeling is choosing the generalized coordinates for the governing equations of motion. Several equivalent choices of generalized coordinates exist, and with the proper selection the generation process of motion equations can be simplified. In this paper, the q_i vertical displacements of each node are applied for generalized coordinates. Let us denote the degrees of freedom (DOF) of the model by n_d . This way the generalized coordinate vector of the model can be expressed as: $q = [q_1 \quad q_2 \quad \dots \quad q_{n_d}]^T$. Here q_1 is the vertical position of the bottom frame and q_{n_d} is the vertical position of mast-tip.

The detailed derivation of the dynamic equations for the before-mentioned multibody model and generalized coordinates can be found in [9, 11]. The matrix equation of motion can be generated in the following form (with the mass matrix M , the damping matrix K and the stiffness matrix S respectively):

$$M\ddot{q} + K\dot{q} + Sq = F. \quad (1)$$

In Equation (1) F is the vector of external excitation forces. In this work a single-input system is investigated, where the input signal of the model is the external force F_i acting on the bottom frame. Thus, in vector F only the first coordinate is nonzero.

The controller synthesis methods applied in this paper use the state space representation of the model, thus the matrix equation of motion (1) must be transformed into state space form. As mentioned before the input signal of the model is the external force acting in the direction of q_1 generalized coordinate. In the following steps of this work the model is applied in the synthesis of controller which realizes the positioning control of single-mast stacker cranes with reduced mast-vibrations. Therefore, two kinds of outputs are required in the state space presentation of the dynamic model. The first one is used to describe and investigate the mast-vibrations. This output is the inclination of mast, i.e. the position difference between the undermost point of mast and mast-tip. The output is denoted by z . The second output is the so-called measured output. This output is applied for the position control of the stacker crane and can be equal to the horizontal position or velocity of stacker crane. In this work the horizontal position of stacker crane, i.e. the first generalized coordinate is applied as measured output. The output is denoted by y .

The state space representation of the dynamic model is generated in the following form:

$$\dot{x} = Ax + B_1d + B_2u, \quad (2a)$$

$$z = C_1x + D_{11}d + D_{12}u, \quad (2b)$$

$$y = C_2x + D_{21}d, \quad (2c)$$

where x , u , y , d , z are the state vector, control input, measured output, disturbance input and performance output vectors, respectively. The matrices $A \in \mathfrak{R}^{n \times n}$, $B \in \mathfrak{R}^{n \times m}$, $C \in \mathfrak{R}^{p \times n}$, $D \in \mathfrak{R}^{p \times m}$ are the so-called system matrices. Here n is known as the order of the system and m , p are the number of all input and output variables of the system respectively. As can be seen in equation (2) the matrices B , C , D are usually partitioned according to the kinds of input and output signals.

In the actual case of this stacker crane dynamic model the disturbance input does not exist. The state vector with the above-mentioned generalized coordinate vector is defined as:

$$x = [\dot{q} \quad q]^T. \quad (3)$$

Using this definition, the state space representation of the investigated multibody model can be generated - taking notice of the above-mentioned definition of input and output signals - with the following considerations. Extending the equation (1) with the identity $M\dot{x} - M\dot{x} = 0$ the system matrices A and B can be computed by means of expressing the derivative of state vector from the extended system:

$$A = \begin{bmatrix} -M^{-1}K & -M^{-1}S \\ I & 0 \end{bmatrix}, \quad (4a)$$

$$B = \begin{bmatrix} -M^{-1}F \\ 0 \end{bmatrix}, \quad (4b)$$

where 0 is a zero matrix/vector and I is an identity matrix with the corresponding size.

As mentioned before the investigated model must fulfill the requirements of controller synthesis techniques. The multibody model introduced in this section has almost one hundred degrees of freedom, thus the order of state space representation of this model is near two hundred. This complicated, high order model is not suitable for controller design since it causes numerical problems in controller synthesis methods of modern control theory, e.g. \mathcal{H}_∞ method. A smaller size model also can speed up the simulation process during the design validation phase. Because of the above-mentioned reasons our investigated model is reduced with a suitable model order reduction method, see [10].

3 Mixed-Sensitivity Loop Shaping Control of the Stacker Crane

A frequently applied and well-known control design approach in \mathcal{H}_∞ control theory is the so-called loop shaping procedure presented in [12]. In this section, the \mathcal{H}_∞ control design method of stacker cranes using the mixed-sensitivity loop shaping approach is presented. The aim of this section is to analyze the influence of several loop shaping weighting strategies on the main control objectives (i.e. the reference signal tracking and the mast vibration attenuation). This may help later to generate more complex and advanced weighting strategies in order to improve the control performances. For the purpose of control design the nominal model of stacker crane - with the lifted load in the highest position - is used, thus in this section the nominal performances are investigated without model uncertainties.

The augmented plant for mixed-sensitivity loop shaping is presented in Figure 1. As shown in Figure 1 the weighting functions W_1 , W_2 and W_3 penalize the error signal, control signal, and output signal respectively. The weighting functions W_1 , W_2 and W_3 must be proper and stable transfer functions. In the actual control design $W_2 = 0$, while W_1 and W_3 have the following general form:

$$W_1 = \frac{s/M_1 + \omega_1}{s + \omega_1 A_1}, \quad W_3 = \frac{s/M_3 + \omega_3}{s + \omega_3 A_3}. \quad (5)$$

This way the low-frequency asymptote (A_i), the high-frequency asymptote (M_i) as well as the bandwidth (ω_i) of weighting functions can be adjusted. These parameters have a fundamental role in the loop shaping procedure.

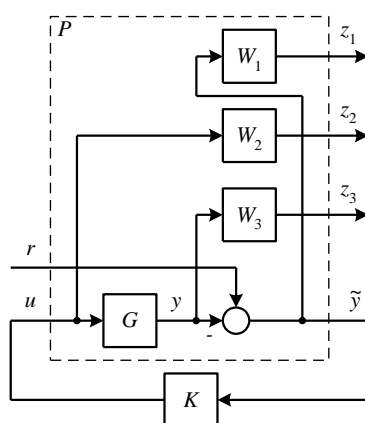

Figure 1

Augmented plant for mixed-sensitivity loop shaping

The disturbance input and the controlled output of the augmented plant are defined as: $\tilde{w} = r$ and $\tilde{z} = [z_1 \ z_2 \ z_3]^T$ respectively. The measured output is equal to: $\tilde{y} = r - y$. Using the above-mentioned definitions of input- and output signals it is easy to verify that the closed loop transfer function matrix $T_{\tilde{z}\tilde{w}}$ from \tilde{w} to \tilde{z} can be expressed as:

$$T_{\tilde{z}\tilde{w}} = \begin{bmatrix} W_1 S \\ W_2 K S \\ W_3 T \end{bmatrix}, \quad (6)$$

where $S = (I + PK)^{-1}$ and $T = PK(I + PK)^{-1}$ are the sensitivity function and complementary sensitivity function of closed loop system respectively.

As mentioned before in the actual design cases the weighting function W_2 is equal to zero, thus the performance objective of \mathcal{H}_∞ control design implies the following conditions:

$$|W_1 S| \leq \gamma, \quad |W_3 T| \leq \gamma. \quad (7)$$

Therefore, the weighting functions W_1 and W_3 determine the shapes of sensitivity function S and complementary sensitivity function T . Typically, the inverse of W_1 is chosen to be small inside the desired control bandwidth to achieve proper performance (e.g. disturbance attenuation or tracking), and the inverse of W_3 is chosen to be small outside the control bandwidth, which helps to ensure proper stability margin (i.e. robustness).

Table 1
Parameters of loop shaping

Case #1	Case #2
$A_1 = 100$	$A_1 = 100$
$M_1 = 0.01$	$M_1 = 0.01$
$\omega_1 = 5.0 \text{ rad/s}$	$\omega_1 = 0.5 \text{ rad/s}$
$A_3 = 0.01$	$A_3 = 0.01$
$M_3 = 100$	$M_3 = 100$
$\omega_3 = 20 \text{ rad/s}$	$\omega_3 = 2.0 \text{ rad/s}$
$\gamma = 0.9004$	$\gamma = 0.9012$

By the variation of the parameters of these weighting functions two kinds of controllers are designed. In these controller design cases the desired control bandwidth is adjusted to 1 rad/s and 10 rad/s respectively. The parameters of performance weighting functions according to the above-mentioned design cases are summarized in Table 1.

The calculations of designed controllers can be carried out, e.g. by means of the solution method presented in [7]. The achieved performance levels for each design cases are also presented in Table 1.

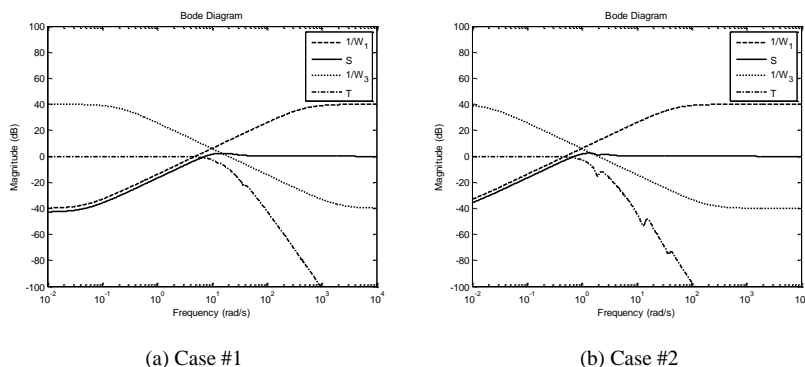
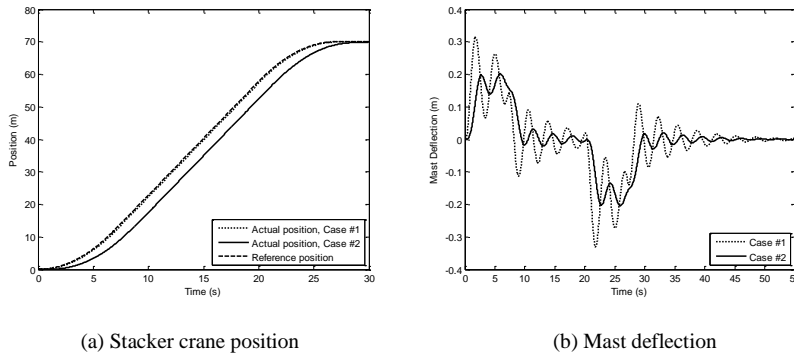

Figure 2

Performance objectives for loop shaping

The performance objectives for the closed-loop system in both design cases can be analyzed by means of Figure 2. As shown in the figure by means of the weighting function W_1 the sensitivity function is shaped so that its gain is below -40 dB in the low-frequency range. This ensures a low (practically under 1%) steady-state tracking error. The minimum control bandwidth is adjusted by the 0 dB crossover frequency of weighting function W_1 , while the upper limit of control bandwidth is given by the 0 dB crossover frequency of W_3 .

The simulation results, i.e. diagrams of stacker crane position and mast deflection are shown in Figure 3. During simulations the position signal of a general stacker crane moving cycle is used as the reference signal. In the first session of moving cycle the stacker crane has constant 0.5 m/s^2 desired acceleration. In the second session the desired velocity is 3.5 m/s and the deceleration value of the third session is -0.5 m/s^2 . Distance covered of the moving cycle is 70 m while the total cycle time is 27 seconds.



(a) Stacker crane position

(b) Mast deflection

Figure 3

Simulation results of loop shaping

Analyzing the simulations above it can be concluded that the reference signal tracking and the vibration attenuation properties can be adjusted by means of the proposed method. However, better performances can be achieved by means of more advanced weighting strategies. Another interesting observation about the simulation results is that the magnitude of mast vibrations is inversely proportional to the control error. Thus, a trade-off between mast vibration attenuation and control error can be determined. Additionally, the modeling uncertainties also must be taken into consideration in the control design method.

4 Robust Control Design for the Stacker Crane

The aim of this section is the presentation of a robust controller design method which can handle the uncertainties in the dynamic model and at the same time have proper reference signal tracking and mast vibration attenuation properties. For applying the \mathcal{H}_∞ robust control approach first the control objectives must be formulated. In this section, the essential requirements for the closed-loop system (i.e. the proper reference signal tracking property and the mast-vibration attenuation) are defined, a more sophisticated way, by means of advanced weighting strategies in the generalized plant. Similar to the loop shaping case here the reference signal of investigated model is also the horizontal position demand of the stacker crane. The augmented plant for robust control design is shown in Figure 4. Since in this augmented plant both output signals of the stacker crane dynamic model are used, the vector-valued signals are denoted by thick lines. This way the diagram of the augmented plant can be simplified.

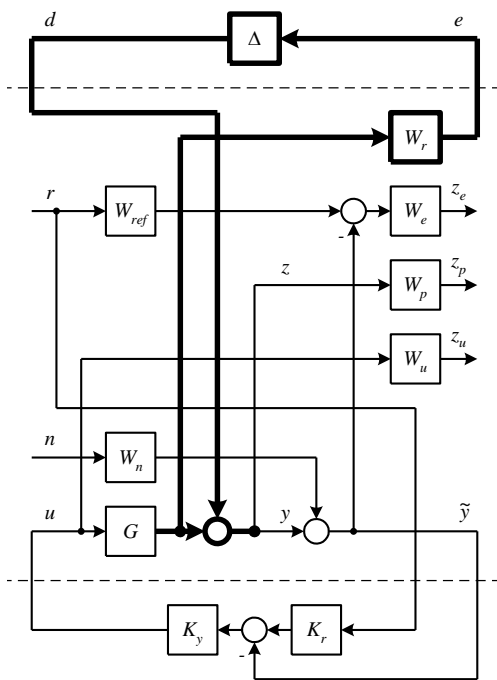

Figure 4
Augmented plant for robust control

As shown in Figure 4 here the controller K is partitioned into a feedback part K_y and a pre-filter part K_r . This controller structure is connected to the second output of the stacker crane model (i.e. the position output y). The aim of this structure is to provide for proper reference signal tracking properties in the positioning control of stacker crane.

The purpose of the transfer function W_{ref} is to represent the desired behavior of the closed loop system. It is usually a second-order transfer function with free parameters ω_r and ζ , i.e. $W_{ref} = \frac{\omega_r^2}{s^2 + 2\zeta\omega_r s + \omega_r^2}$.

By means of the free parameters of W_{ref} the bandwidth and damping of the ideal closed-loop transfer function can be adjusted. The difference between W_{ref} and the actual closed-loop transfer function is penalized by the transfer function W_e . The value of this penalty function should be large in the frequency range where small errors are desired and are small where larger errors can be tolerated. In most cases, the more accurate model is required in the low-frequency range thus W_e is a low pass filter.

The aim of the weighting function W_p is to penalize the harmful mast vibrations. Therefore, this weighting function is connected to the first output of the stacker crane model (i.e. the mast-inclination output z). Since penalizing the final, steady-state value of mast inclination (which depends on the acceleration of stacker crane motion) is unnecessary, the W_p transfer function is a high pass filter.

Some further performance specifications are also added to the control design augmented plant. In the high-frequency range the control input is limited by using the performance weighting function W_u , as well as the purpose of the weighting function W_n is to reflect the sensor noises. Finally, the weighing function matrix W_r reflects the amount of uncertainty and it can be determined by the procedure mentioned in [9] and [10].

The transfer function matrix of the generalized plant can be expressed as follows.

$$\begin{bmatrix} e \\ z_e \\ z_p \\ z_u \\ r \\ \tilde{y} \end{bmatrix} = \begin{bmatrix} 0 & 0 & 0 & W_r G \\ -W_e & W_e W_{ref} & -W_e W_n & -W_e G_{yu} \\ W_p & 0 & 0 & W_p G_{zu} \\ 0 & 0 & 0 & W_u \\ 0 & I & 0 & 0 \\ I & 0 & W_n & G_{yu} \end{bmatrix} \begin{bmatrix} d \\ r \\ n \\ u \end{bmatrix}. \quad (8)$$

Due to the two degrees of freedom controller structure the corresponding feedback relation is: $u = K[r \quad \tilde{y}]^T$.

During the actual investigations the lifted load position varies in position range from 41 to 44 *m* which generates the model uncertainty. This helps to keep the amount of uncertainty sufficiently small. The nominal model of the model set that generates the uncertainty is the model with lifted load position in the middle of position range, i.e. 42.5 *m*.

In order to analyze the proposed robust control design method two kinds of control design cases are generated. The first weighting strategy (Case #1) focuses on the adequate reference signal tracking rather than mast-vibration attenuation. While in the second strategy (Case #2) the mast-vibrations are penalized more. In the control design cases for the model matching function W_{ref} the following parameter values are applied: $\omega_r = 8 \text{ rad/s}$, $\zeta = 1$. The performance weighting functions according to the above-mentioned design cases are summarized in Table 2. As shown in the table the weighting functions of control input and sensor noises are permanent for both design cases.

Table 2
Weighting functions for robust control design

Case #1	Case #2
$W_e = 100 \frac{1+0.1s}{1+10s}$	$W_e = 80 \frac{1+s}{1+100s}$
$W_p = 0.1 \frac{1+0.1s}{1+0.001s}$	$W_p = 0.1 \frac{1+s}{1+0.01s}$
$W_u = 4 \cdot 10^{-6} \frac{1+0.01s}{1+0.001s}$	$W_u = 4 \cdot 10^{-6} \frac{1+0.01s}{1+0.001s}$
$W_n = 0.01 \frac{1+0.1s}{1+0.01s}$	$W_n = 0.01 \frac{1+0.1s}{1+0.01s}$

The investigation of the properties of designed controllers can be carried out by means of time-domain analysis. In this simulation, as a reference signal, the same position signal is used as in the case of loop shaping control design, see in Section 3. The simulation results (i.e. the stacker crane position and mast deflection functions) are shown in Figure 5.

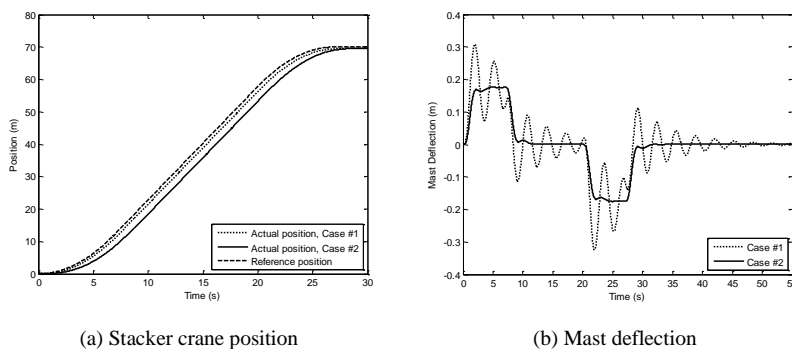

Figure 5

Simulation results of robust control

For the comparison of above mentioned time-domain results the following quantities are defined. The rate of mast vibrations is measured by the overshoot of mast deflection signal in the acceleration phase of movement:

$$\sigma_a = \frac{\max_t |z(t) - z(\infty)|}{|z(\infty)|}. \quad (9)$$

The reference signal tracking properties can be investigated by means of the steady-state tracking error e_r , as well as the actual cycle time t_c (which is the total time necessary to reach the final position of stacker crane). The steady-state tracking error can be defined as:

$$e_r = \frac{|y(\infty) - r(\infty)|}{|r(\infty)|}. \quad (10)$$

These time-domain quantities according to the two design cases are shown in Table 3.

Table 3
Time-domain analysis results of design cases

Case #1	Case #2
$\sigma_a = 71.6 \%$	$\sigma_a = 0 \%$
$e_r = 0.70 \%$	$e_r = 0.40 \%$
$t_c = 27.4 \text{ s}$	$t_c = 29.3 \text{ s}$

As can be seen in the presented simulation results the inverse proportionality between the magnitude of mast vibrations and control error here also exists. Therefore, in controller design the trade-off between mast-vibration attenuation and cycle time of stacker crane motion can be found. To explore this trade-off a series of controller designs and time-domain analyses are carried out again with several W_e and W_p weighting functions. In these investigations the control input and sensor noises weighting functions were permanent and identical to the functions presented in Table 2. During the investigations the weighting strategy has changed from the cycle time focusing cases to the vibration attenuation focusing cases. In the presented eleven design cases the 0 dB crossover frequencies of weighting functions W_e and W_p are modified evenly between its extreme values. In the case of W_e this crossover frequency is modified from 2 rad/s to 1 rad/s, while in the case of W_p function this value is changed from 20 rad/s to 10 rad/s.

In order to find an ideal design case the overshoot and the cycle time values of every design case are plotted in Figure 6. Analyzing the data of Figure 6 it can be observed that the overshoot of mast deflection signal vanishes sharply before the cycle time of stacker crane motion considerable starts to increase. Therefore, a sufficient trade-off between conflicting performances can be found.

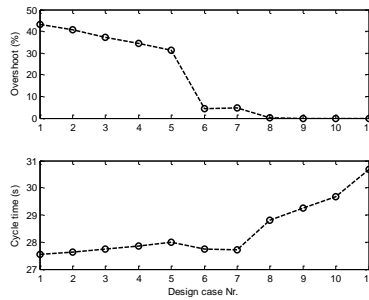

Figure 6

Trade-off between mast-vibration and cycle time

The designed controllers are calculated by means of the so-called μ -synthesis method presented in [19]. The achieved structured singular values μ for each the design cases are also plotted in the diagram of Figure 7. As shown in the figure, although the robust stability and nominal performance is achieved, guaranteeing the robust performance is a challenging task due to the strict performance specifications. However, as can be seen in Figure 7 the proposed method guarantees robust performance in the interesting region of the design cases where the vibrations are sufficiently damped.

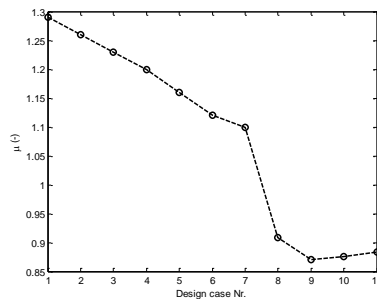

Figure 7

Achieved μ values of design cases

Conclusions

In the paper a robust controller design method was developed which is able to handle the uncertainties in the dynamic model of single-mast stacker cranes and at the same time has excellent reference signal tracking and mast-vibration attenuation properties. In the first part of the paper the dynamic modeling of single-mast stacker cranes by means of multibody modeling approach was briefly summarized. The unstructured uncertainty approach was applied to handle the varying dynamical behavior due to varying lifted load position. A robust control method was developed which is suitable for positioning control of stacker cranes

with reduced mast-vibrations in the presence of model uncertainties. By means of a controller design example the trade-off between mast-vibration attenuation and cycle time of stacker crane motion was also presented. The developed designing method is suitable for finding the controller which produces the desired motion cycle time and mast-vibration free stacker crane motion.

References

- [1] Jorge Angeles and Andr s Kecskem thy. *Kinematics and Dynamics of Multi-body Systems*. Springer-Verlag, 1995
- [2] Dieter Arnold and Michael Dietzel. Aktive Schwingungsd mpfung von Regalbedienger ten. *F+H F rdern und Heben*, 50(1-2):50-52, 2000
- [3] Javier Garc a de Jal n and Eduardo Bayo. *Kinematic and Dynamic Simulation of Multibody Systems - The Real-Time Challenge*. Springer-Verlag, 1994
- [4] Michael Dietzel. Beeinflussung des Schwingungsverhaltens von Regalbedienger ten durch Regelung des Fahrtriebs. Dissertation, Institut f r F rdertechnik Karlsruhe, 1999
- [5] John C. Doyle et al. State-space solutions to standard \mathcal{H}_2 and \mathcal{H}_∞ control problems. *IEEE Transactions on Automatic Control*, 34(8):831-847, 1989
- [6] B. A. Francis, J. W. Helton, and G. Zames. \mathcal{H}_∞ optimal feedback controllers for linear multivariable systems. *IEEE Transactions on Automatic Control*, 29(10):888-900, 1984
- [7] Pascal Gahinet and Pierre Apkarian. A linear matrix inequality approach to \mathcal{H}_∞ control. *International Journal of Robust and Nonlinear Control*, 4:421-448, 1994
- [8] Keith Glover and John C. Doyle. State-space formulae for all stabilizing controllers that satisfy an \mathcal{H}_∞ -norm bound and relations to risk sensitivity. *Systems and Control Letters*, 11:167-172, 1988
- [9] S ndor Hajdu and P ter G sp r. Investigation of the influence of lifted load on dynamical behavior of stacker cranes through unstructured uncertainties. In *CINTI 2013 : Proceeding of the 14th IEEE International Symposium on Computational Intelligence and Informatics, Budapest: IEEE Hungary Section*, pages 179.184, 2013
- [10] S ndor Hajdu and P ter G sp r. From modeling to robust control design of single-mast stacker cranes. *Acta Polytechnica Hungarica*, 11(10):135-149, 2014
- [11] S ndor Hajdu and P ter G sp r. Multi-body modeling of single-mast stacker cranes. *International Journal of Engineering Systems Modelling and Simulation*, 8(3):218-226, 2016

-
- [12] D. McFarlane and K. Glover. A loop shaping design procedure using \mathcal{H}_∞ synthesis. *IEEE Transactions on Automatic Control*, 37(6):759-769, 1992
- [13] József Polák and István Lakatos. Hajtómű matematikai modell elemzése, In: Péter Tamás (szerk.), *Innováció és fenntartható felszíni közlekedés: IFFK 2015. Konferencia helye, ideje: Budapest, Magyarország, 2015.10.15-2015.10.16.*, Budapest: Magyar Mérnökakadémia (MMA), 2015
- [14] József Polák and István Lakatos. Examination of drive line mathematical model. *Machine design* 8(1):33-36, 2016
- [15] József Polák and István Lakatos. Efficiency optimization of electric permanent magnet motor driven vehicle. *Machine design* 7(1):11-14, 2015
- [16] József Polák and István Lakatos. Analysis of propulsion unit mathematical model. *Machine design* 7(4):137-140, 2015
- [17] Karl-Heinz Reisinger. Schwingungssimulation von Regalförderzeugen. Dissertation, Technische Universität Graz, 1998
- [18] Meinhard Schumacher. Untersuchung des Schwingungsverhaltens von Einmast-Regalbediengeräten. Dissertation, Institut für Fördertechnik Karlsruhe, 1994
- [19] Kemin Zhou, John C. Doyle, and Keith Glover. *Robust and Optimal Control*. Prentice Hall, New Jersey, 1996