

TR90-66v

Synthetic and Spectrometric investigation of 1,4-benzoxazepines.

THESIS

Submitted in fulfilment of the requirements for the degree of

Master of Science

of Rhodes University.

by

R.D. Whittal

January 1990

Department of Chemistry

Rhodes University

Grahamstown

ABSTRACT

Flavanone (2,3-dihydro-2-phenyl-4H-benzopyran-4-one) and a series of 4'- and 7-halogeno derivatives were prepared from the corresponding 2'-hydroxy-chalcones [1-(2-hydroxyphenyl)-3-phenyl-2-propen-1-ones], which, in turn, were synthesized by aldol condensation of substituted 2'-hydroxyacetophenones with various benzaldehydes.

A series of 2,3-dihydro-2-phenyl-1,4-benzoxazepin-5(4H)-ones were prepared by ring expansion of the corresponding flavanones, *via* the Schmidt reaction, using trimethylsilylazide and trifluoroacetic acid. A series of tetrazoles {2,3-dihydro-2-phenyl-tetrazolo[1,5-d]-1,4-benzoxazepines} were also isolated as by-products of the Schmidt reaction. Flavanone oxime was synthesized for use in Beckmann reactions, and its molecular structure was determined by x-ray crystallography. Attempts to prepare 1,4-benzoxazepinone or its 1,5-analogue *via* Beckmann rearrangement of flavanone oxime, with polyphosphoric acid or phosphorus pentachloride catalysts, however, were unsuccessful. Several methods for introducing Δ^2 -unsaturation into the benzoxazepinone system were also examined.

High resolution ^1H n.m.r., computer modelling, and molecular mechanics techniques were used to determine the conformations of the heterocycles of the benzoxazepinones and tetrazoles and results are compared with earlier studies in this field. Certain trends in the fragmentation patterns were observed in the low resolution mass spectra of the benzoxazepinones and tetrazoles, and high resolution mass spectrometric data were used to explore the major fragmentation patterns of these compounds.

ACKNOWLEDGEMENTS

I would like to take this opportunity to thank Professor Kaye for his assistance, guidance and supervision of this project. Without his help throughout, and particularly in the final stages of this task, nothing would have been possible.

I would also like to thank my parents for supporting me in this venture. They were always there with an encouraging word and a positive thought to keep me going.

NOMENCLATURE

A short note on nomenclature is warranted as this is not consistent throughout the thesis. Chalcones [e.g. (I)] and Flavanones [e.g. (II)] have been named as such throughout the INTRODUCTION and the DISCUSSION sections of this thesis for the sake of brevity. In the EXPERIMENTAL section however, the modern I.U.P.A.C. systematic nomenclature is used to avoid ambiguities arising from the use of primes. So, for example, chalcone (I) will be named according to its parent system *i.e.* 1-(2-hydroxyphenyl)-3-phenyl-2-propen-1-one and flavanone (II) will be named as a benzopyran-4-one system *i.e.* 2,3-dihydro-2-phenyl-4H-benzopyran-4-one. 2,3-Dihydro-2-phenyl-1,4-benzoxazepin-5(4H)-ones (III) will be referred to as benzoxazepinones, and 2,3-dihydro-2-phenyl-tetrazolo[1,5-d]-1,4-benzoxazepines (IV) will be referred to as tetrazoles. The numbering system of the respective compounds is shown below.

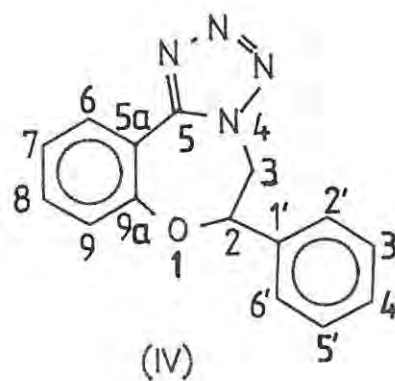
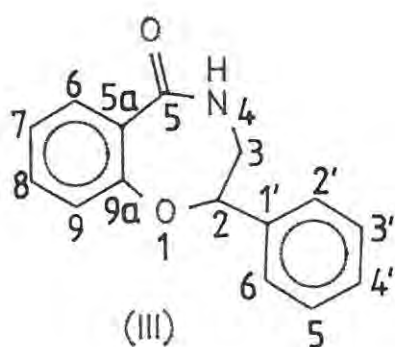
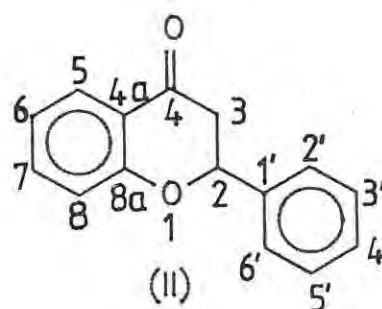
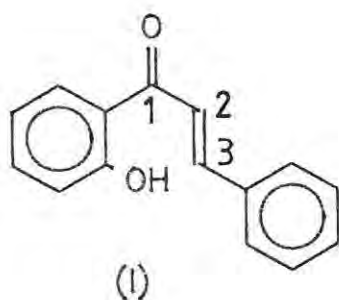

	<u>Page</u>
1. INTRODUCTION	1
1.1. A literature survey of the structure and synthesis of the flavanones and benzoxazepinones	1
1.1.1. Origins of the flavanones	
1.1.2. Synthesis of the flavanones	
1.1.3. Origins and synthesis of the benzoxazepinones	
1.2. The biological activity of the flavanones and benzoxazepinones	16
1.2.1. The flavanones	
1.2.2. The benzoxazepinones	
1.3. Aims of the current investigation	22
2. DISCUSSION	23
2.1. Synthesis of flavanones and the benzoxazepinones	23
2.1.1. Preparation of the 2'-hydroxyacetophenones	
2.1.2. Preparation of the chalcones (15, 57-62) and flavanones (1, 63-68)	
2.1.3. Preparation of the benzoxazepinones	
2.1.3.1. The attempted Beckmann rearrangement of flavanone oxime (73)	
2.1.3.2. The Schmidt Rearrangement	
2.1.4. Further reactions of the benzoxazepinone system	
2.2. Mass-spectrometric studies of the benzoxazepinones and tetrazoles	53
2.3. Conformational analysis of the benzoxazepinones and tetrazoles	63
2.3.1. ¹ H n.m.r. techniques	
2.3.2. Molecular modelling	
3. EXPERIMENTAL	72
4. REFERENCES	93
5. APPENDICES	98

1. INTRODUCTION

1.1. A literature survey of the structure and synthesis of the flavanones and benzoxazepinones

1.1.1. Origins of the flavanones

The flavanones belong to a large group of compounds called the flavonoids which are found almost exclusively in higher plants. Many members of the flavonoid group are highly coloured and have an important function as pigments in plants. They have been extensively studied and reviewed since their discovery in the late nineteenth century and only a brief treatment will be given here.^{1,2} The flavanones (1) are closely related in structure to the flavones (2), the anthocyanins (3), and the catechins (4). The above-mentioned compounds differ only in the degree of oxidation at the various carbon centres indicated in structure (5).³

Flavanones are 2-phenyl derivatives of chromanones (6), the latter being the saturated analogues of the chromones (7). Some chromones, *e.g.* khellin (8) and chromoglycic acid (Intal®) (9) are important biologically active compounds.

The biosynthetic pathway for formation of the flavanones has been established and involves the condensation of a cinnamate unit (10) with three acetate units in a polyketide synthesis (Scheme 1).³ The polyketone chain cyclises to afford the A-ring and the three hydroxyl functions observed in the chalcone (11). Oxidation of the B-ring occurs later in the biosynthesis and is effected by molecular oxygen.

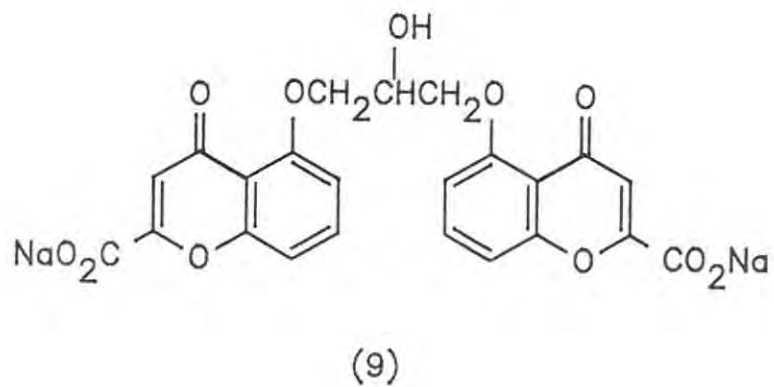
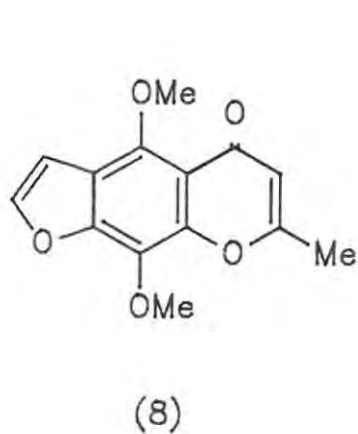
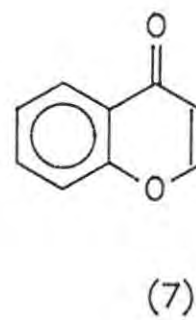
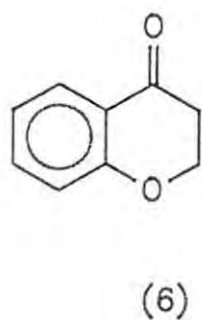
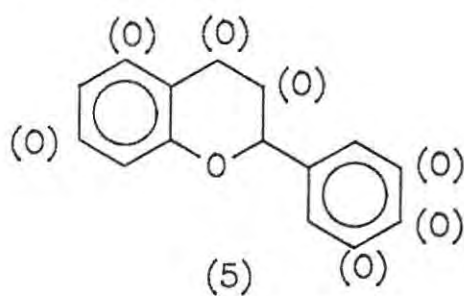
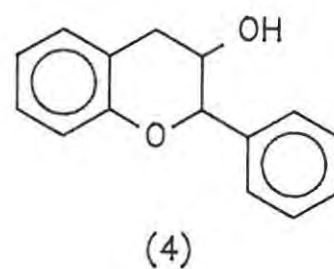
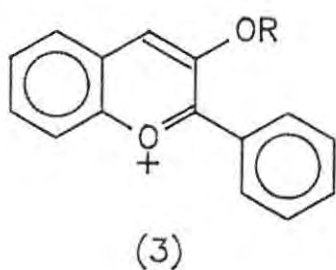
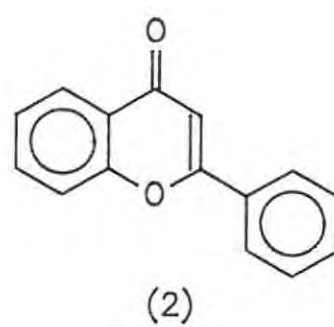
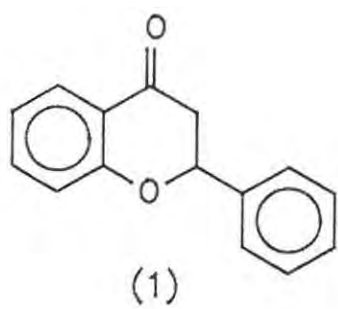

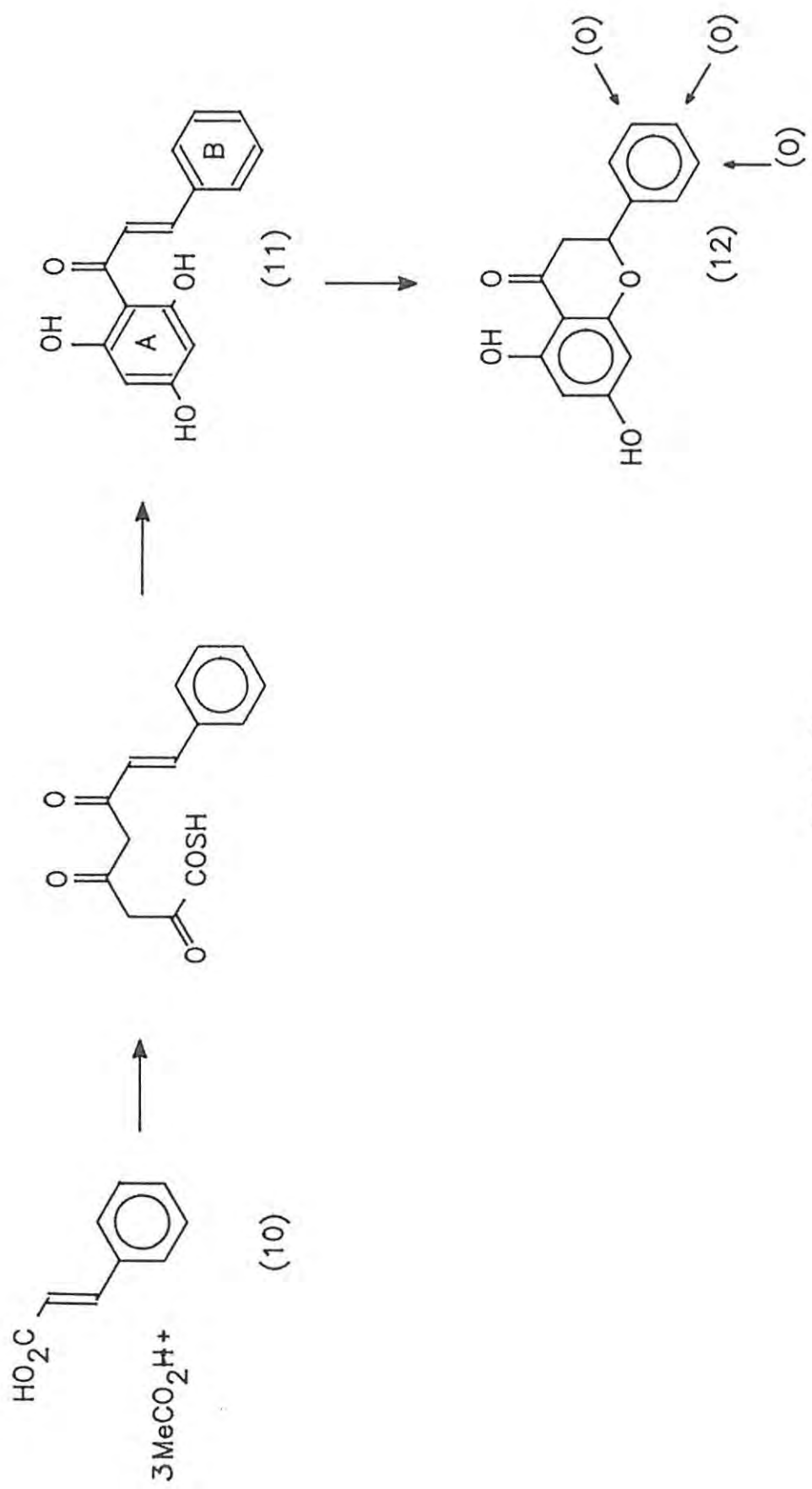

SCHEME 1

The large variety of flavanones results from the incidence of oxygen functions at key sites in compound (12), which can be *O*-alkylated or form glycosides. Sugars which are most commonly associated with flavanones are rhamnose and glucose.

1.1.2. Synthesis of the flavanones

The most common laboratory synthesis of the flavanones mimics the biosynthesis insofar as the formation of the chalcone (15) is followed by cyclisation to the isomeric flavanone (1). However, the laboratory precursors to the chalcones are normally more complex than those found in nature, and the synthesis begins with the base catalysed aldol condensation of a 2'-hydroxyacetophenone [*e.g.* (13)] with a substituted benzaldehyde [*e.g.* (14)] which affords the required chalcone [*e.g.* (15)], usually in good yield. This condensation is followed by an acid or base catalysed cyclisation (involving Michael addition) to form the flavanone (1) (Scheme 2). The flavones (16) can be prepared directly from the chalcones or *via* the flavanones by oxidation with selenium dioxide.^{3,4}

Chalcones may also be prepared by *C*-alkylation of a phenol with the appropriate cinnamoyl system, either directly or by Fries rearrangement (Scheme 3).^{5,6,7} Simonis and Lear⁸ synthesized chalcones by acylation of phenols with cinnamoyl chloride, but the drawback of this method is that both the *para*-position and the phenolic hydroxyl group have to be protected to prevent mixtures of products being formed.

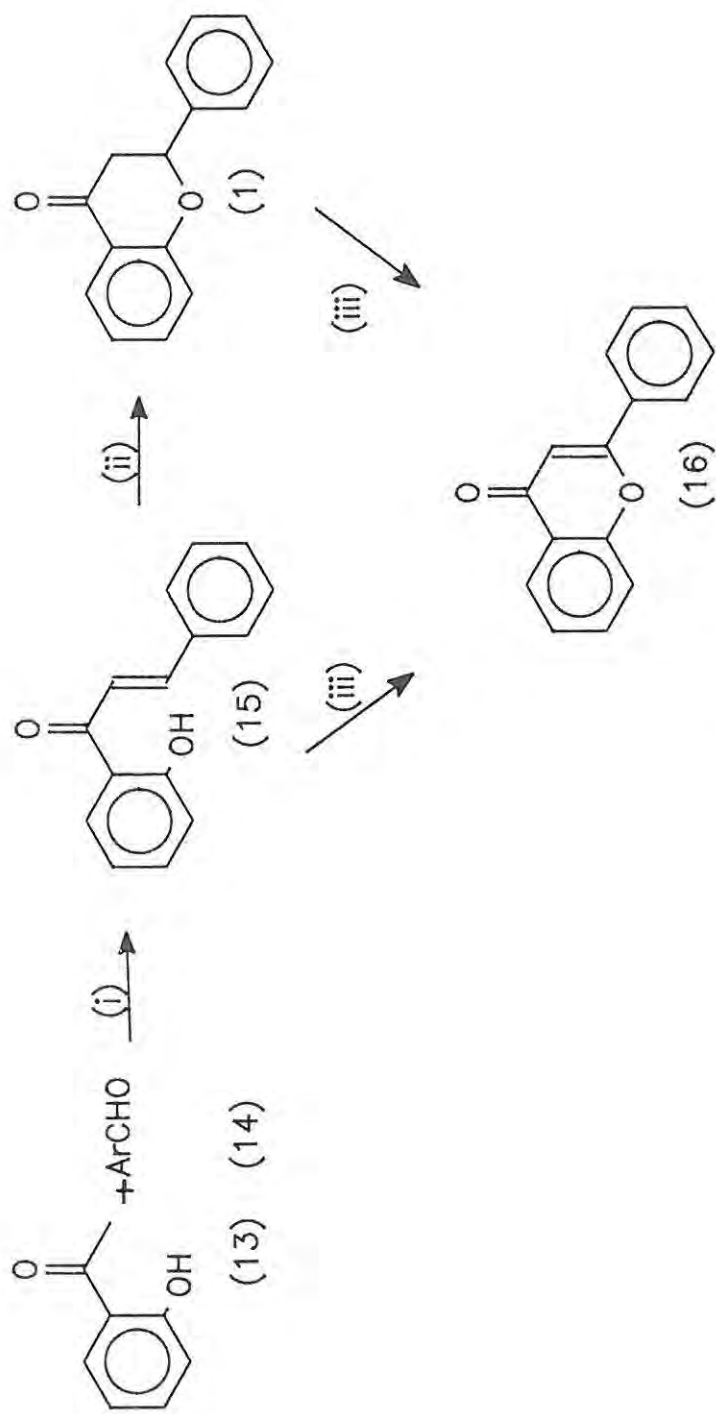

SCHEME 2

Reagents: (i) Base, (ii) Acid or base, (iii) SeO₂

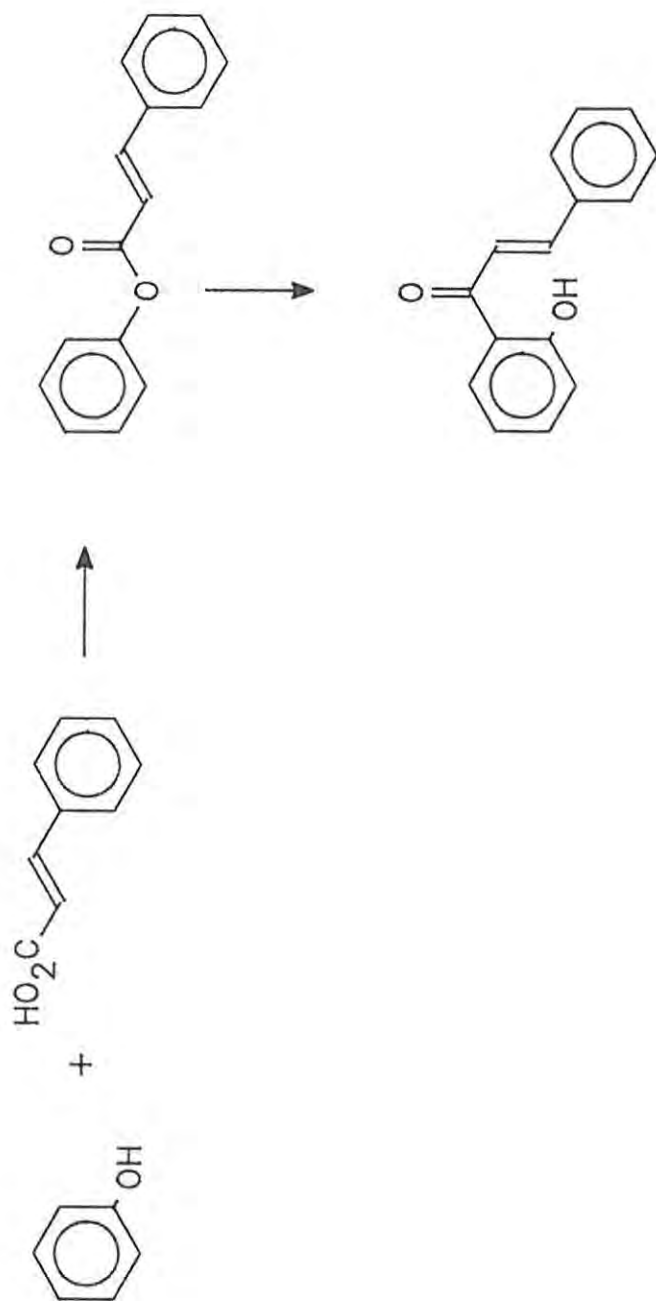

SCHEME 3

Cyclisation of the chalcones to flavanones has been achieved using both acid and base catalysis, and the mechanism of ring closure has been closely studied.^{9,10,11} Bases which have been used include pyridine,¹² potassium carbonate,¹³ butylamine,¹⁴ and dilute sodium hydroxide.¹⁵

Acid catalysts which have been used in the cyclisation step include hydrochloric acid which was very common in early work, hydrogen fluoride,⁵ acetic acid containing a small amount of mineral acid,¹⁶ and *ortho*-phosphoric acid which, at present, is possibly the most common reagent used for effecting the transformation. Ring-closure in acid is incomplete and very slow, requiring reaction times of several days.⁹

Solvent and acid concentration effects have also been studied¹⁷ and it was discovered that the reaction time for ring closure could be decreased by using a higher boiling solvent. The observed trend was that the higher alcohols provided the shortest reaction times (propanol < ethanol < methanol). Alcohols above butanol were found to be unsuitable as they promoted side reactions. The acid concentration was found to have very little influence on the overall yield or rate of the cyclisation reaction.

Flavanones may be isomerised to chalcones by traces of base and are therefore difficult to obtain in the pure state. Several methods of purification have been successfully attempted. Neu¹⁸ separated flavanones and chalcones by column chromatography on a column packed with polyamide powder and eluted with a methanol-water mixture. Unfortunately, the yields of pure flavanones obtained by this method were not very good. Some flavanone and chalcone derivatives have also been separated by gas chromatography¹⁹ but this is obviously not a method for producing pure flavanones in the quantities

required for a multistep synthesis. The most common method of separating chalcones and flavanones is by simply evaporating a large portion of the solvent from the reaction mixture and allowing the flavanone, which is usually less soluble than the chalcone, to crystallise out of the concentrate.

1.1.3. Origins and synthesis of the benzoxazepinones

the oxazepines are seven membered rings containing a nitrogen and oxygen atom. There are three possible isomers, *viz.*, the 1,2-, 1,3-, and 1,4-oxazepines, which on fusion with a benzene ring give rise to ten isomeric benzoxazepines, resulting in a broad spectrum of compounds. For this reason, this discussion will be restricted, as far as possible, to the benzoxazepines relevant to this study, *viz.*, the 1,5-benzoxazepin-4(5H)-ones (17) and, particularly, the 1,4-benzoxazepin-5(4H)-ones (18)

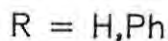
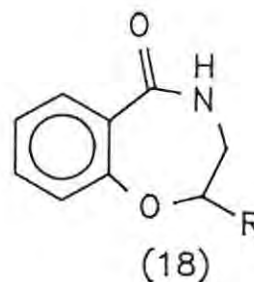
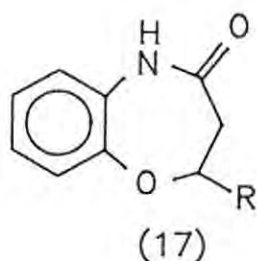

Huckle *et al.*²⁰ in 1965 synthesized the first 1,4-benzoxazepin-5(4H)-one [(18), R = H] by treating chroman-4-one (6) with sodium azide in the presence of acid under the conditions of the Schmidt reaction (Scheme 4). These authors also tried to explain why only one isomer [(18), R = H] was formed when both isomers, *viz.*, [(17), R = H] and [(18), R = H] are theoretically possible.

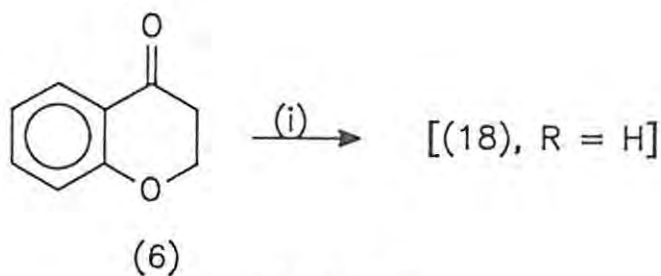

SCHEME 4

Reagents: (i) NaN_3 , H_2SO_4

Evans and Lockhart,²¹ later in the same year, published a paper in which the action of hydrazoic acid on some analogous methoxy derivatives, *viz.*, the 1-tetralone (19) and the acetophenone (20), was examined and compared the results with those obtained in similar reactions with chroman-4-ones. Lansbury and Mancuso²² also studied the Beckmann and Schmidt rearrangements of substituted tetralones and their oximes, as well as mechanistic aspects of the two reactions. Bhalerao and Thyagarajan²³ used a more extensive range of substituted chroman-4-ones (6) to determine the effect of substituents on the outcome of the Schmidt reaction, and the ratios of 1,4-benzoxazepin-5(4H)- and 1,5-benzoxazepin-4(5H)-ones obtained in this way. The conclusions reached by these various groups regarding the mechanism of the Schmidt reaction involving these benzopyran-4-one and tetralone systems is discussed fully in Section 2.3.1.

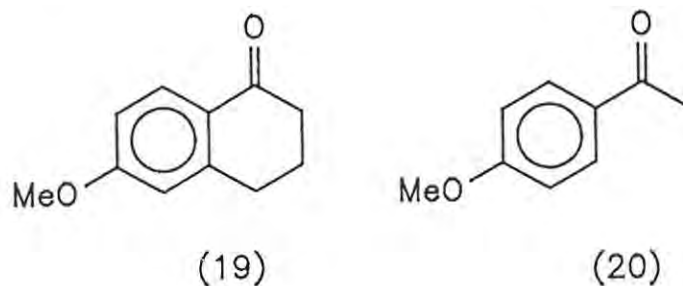

Krapcho and Turk ²⁴ (1967) obtained a patent for work which had been completed some four years earlier (1963), in which they claimed to have synthesized 2,3-dihydro-2-phenyl-1,5-benzoxazepin-4(5H)-one [(17), R = Ph] by reacting flavanone (1) with sodium azide in the presence of acetic acid (Scheme 5).

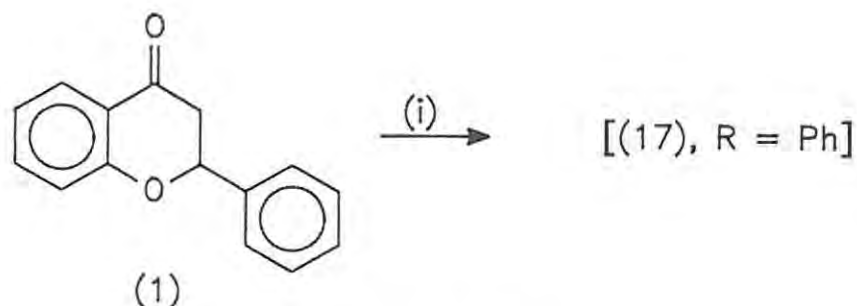

SCHEME 5

Reagents: NaN_3 , AcOH

However, Lockhart ²⁵ later proved that Krapcho and Turk were incorrect and had actually synthesized 2,3-dihydro-2-phenyl-1,4-benzoxazepin-5(4H)-one [(18), R = Ph]. Misiti and Rimatori ²⁶ confirmed these findings and also identified a by-product of the reaction, *viz.*, 2,3-dihydro-2-phenyl-tetrazolo[1,5-d]-1,4-benzoxazepine (21). It was also demonstrated ²⁷ that the

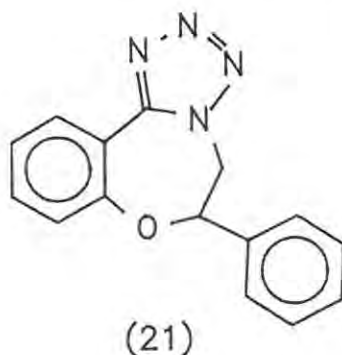

action of hydrazoic acid on 2'-hydroxychalcone afforded *inter alia* compound [(18), R = Ph], but several other by-products were also formed, thereby

precluding use of this reaction as a viable means of obtaining the benzoxazepinones required for this study. Misiti and Rimatori ²⁸ explored the Schmidt reaction on some methyl- and nitroflavanones, and Levai and Bogнар ²⁹ investigated the same reaction on methoxyflavanones and also prepared some *N*-acyl and *N*-alkyl derivatives of the resulting benzoxazepinones. Litkei and Patonay ³⁰ discovered that trimethylsilyl azide afforded the same products in the reaction with flavanones in the presence of trifluoroacetic acid as had been obtained with sodium azide in the presence of mineral acids. In the sodium azide method, charring due to dehydration of the organic compounds by sulphuric acid is a problem. However, with trimethylsilyl azide, the conditions were milder, resulting in less charring, and improved yields were also observed.

All the above methods for obtaining benzoxazepines involve ring-expansion. However, there are several other methods of obtaining these compounds from acyclic starting materials; these methods have desirable attributes and will be discussed briefly. Nour El Din and Shawki ^{31,32} prepared several 2,3-dihydro-1,5-benzoxazepines and their *N*-alkylated and *N*-acylated derivatives as potential psychotropic agents. One of the methods which they used involves the condensation of *o*-hydroxyaniline with 3-chloropropanoyl chloride to give the benzanilide (22), followed by cyclisation in the presence of a strong base to afford the benzoxazepinone [(17), R = H] in an overall yield of 80% (Scheme 6). Besides the excellent yields obtained, this synthesis is relatively short, requiring only two steps.

Schenker ^{33,34} synthesized a series of 3-arylbenzoxazepines by condensing salicylamide (23) with phenacyl chloride (24) in the presence of weak base, followed by dehydration with *para*-toluenesulphonic acid to give the

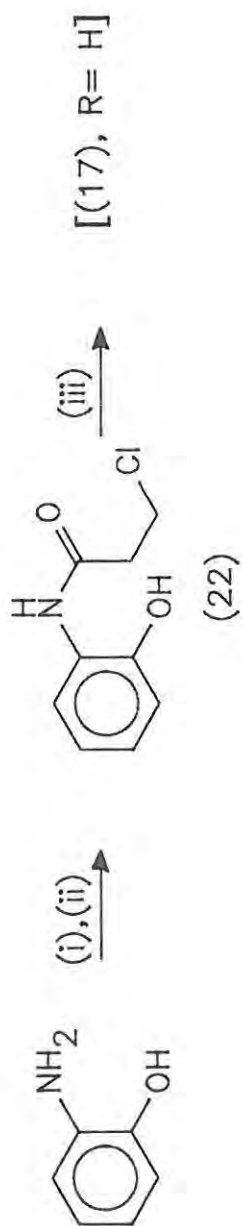

SCHEME 6

Reagents: (i) NaOAc, H₂O, (ii) ClCO(CH₂)₂Cl, (iii) alc. KOH

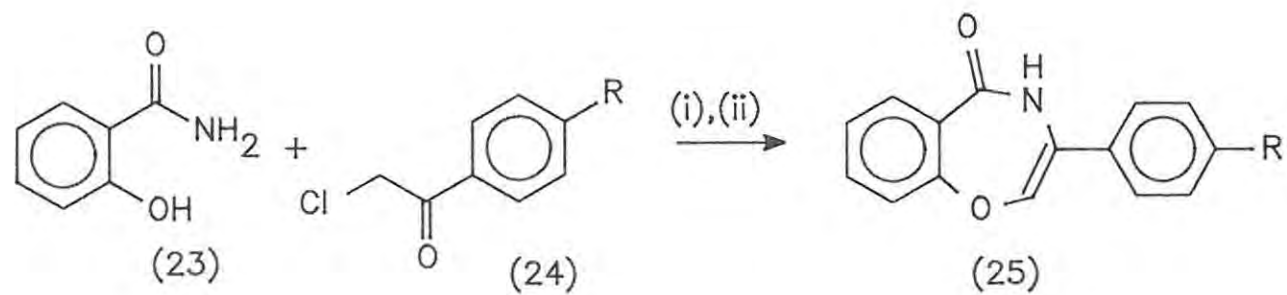

SCHEME 7

Reagents: (i) K_2CO_3 , KI, Acetone, (ii) $4-H_3CC_6H_4SO_3H$

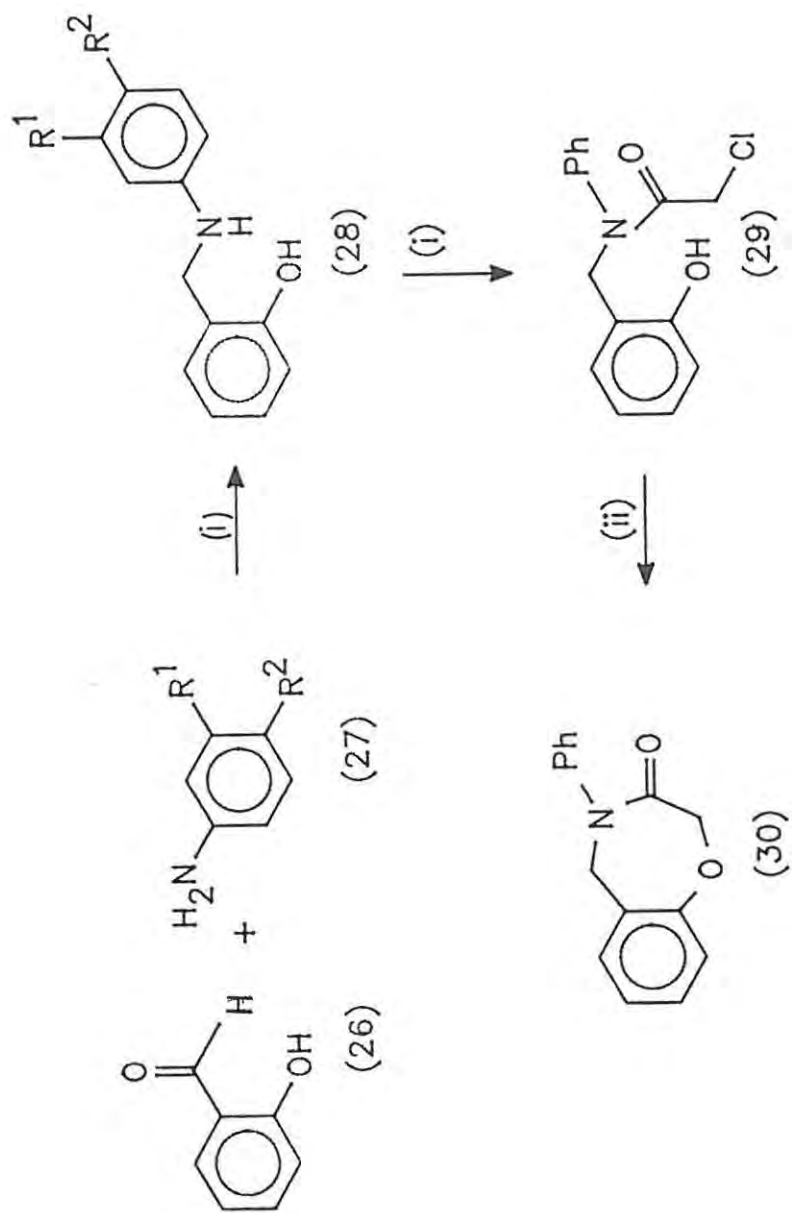

SCHEME 8

Reagents: (i) ClCH_2COCl , (ii) aq. NaOH or KOAc

unsaturated compound (25) (Scheme 7). All the previously discussed methods afford benzoxazepines which have saturated heterocyclic rings. The advantage of Schenker's approach is that it provides a means of synthesizing Δ^2 -substituted benzoxazepines [*e.g.* (25), R = H].

In a somewhat similar process to that used by Schenker above, α -anilino cresols (28) were prepared by the reaction of salicylaldehyde (26) with disubstituted anilines (27). *N*-acylation of compounds (28) gave compounds (29) which were cyclised in dilute alcoholic sodium hydroxide to give the benzoxazepinones (30) (Scheme 8).³⁵

Finally, 4,5-dihydro-1,4-benzoxazepin-3-ones (33) may be prepared by condensing *o*-hydroxybenzylamine (32) with bromoacetyl bromide (31) (Scheme 9).³⁶

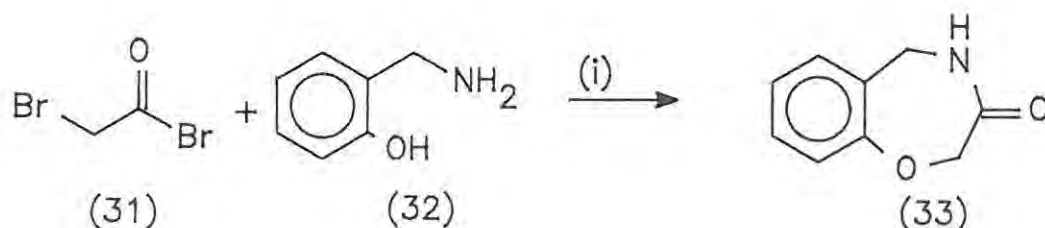

SCHEME 9

Reagent: (i) Base

The advantages of these methods are:— firstly, that they are short, requiring only two or three steps; secondly, that the starting materials are usually readily available; and thirdly, they provide direct access to many 1,4-benzoxazepines. Simply by changing the position of a certain functional group, any number of benzoxazepines may be easily synthesized. However, the most important method of obtaining the benzoxazepines, from the point of

view of this study, is by ring expansion of benzopyran-4-one systems, such as chroman-4-one (6) and flavanone (1).

1.2. The biological activity of the flavanones and benzoxazepinones

1.2.1. The flavanones

Many natural and synthetic flavanones and chalcones have been tested for biological activity against a wide range of diseases and disease causing agents. Most of the flavonoids that are biologically active contain hydroxy or methoxy substituents and some of these, e.g. compounds (34) and (35), have been found to be active against certain strains of bacteria.³⁷

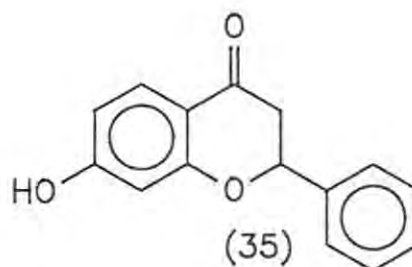
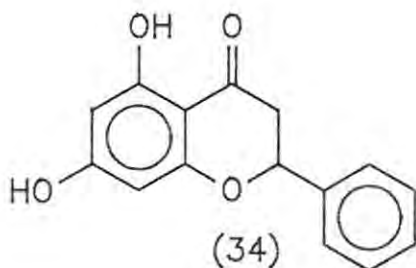

5,7-Dihydroxyflavanone (34) was found to inhibit the growth of the bacterium *staphylococcus aureus* by complexing some of the essential metals and also by altering the cell membrane. 7-Hydroxyflavanone (35) was found to partially inhibit the growth of the same bacterium but the mode of action is different in that the flavanone is thought to be transported into the cytoplasm where it alters the surface of the cell membrane. Edwards *et al.*³⁸ tested many natural and synthetic flavonoids for antineoplastic activity and cytotoxicity and concluded that, in spite of occasional activity, no structure-activity

relationships were observed and that further studies on these compounds as antitumour agents was not warranted. However, several research groups have found that some hydroxy- and methoxyflavanones are antitumour agents ³⁹ and Ueng and Chen ⁴ synthesized a number of tumour inhibitory flavonoids, e.g. 2',5,6',7,8-pentamethoxyflavanone (36).

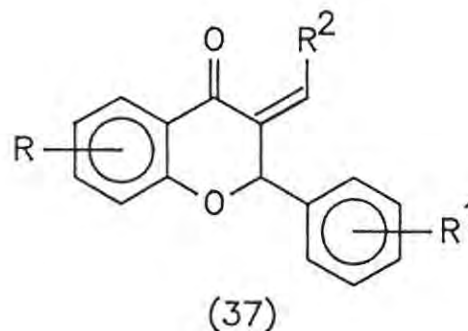
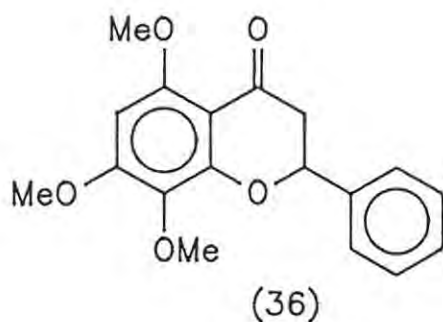

Flavanones have also tested positive as antihelminthics against pinworms in mice ⁴⁰ and as spasmolytic agents, ⁴¹ and their insecticidal properties and toxicity to fish have also been investigated. ⁴³ Several flavanone derivatives (37) were synthesized by Rimbault ⁴⁴ who found them to be useful in the treatment of liver diseases and as mucolytics and immunostimulants.

1.2.2. The benzoxazepinones

The benzoxazepinones are similar in structure to the important class of minor tranquilisers, the benzodiazepines. The benzoxazepinones and the benzodiazepines are similar in that both contain a seven membered, heterocyclic ring, which is fused to a benzene ring. Also, the heterocycle contains two heteroatoms in both classes of compounds. A short discussion of the benzodiazepines is warranted, as both classes of compounds may also have similar biological activity.

The serendipitous discovery of chlordiazepoxide (38) in 1957 as an anxiolytic agent resulted in many other experimental analogues being synthesized and tested for psychotropic properties. An example is diazepam (39) which is ten times more potent than chlordiazepoxide (38).⁴⁵

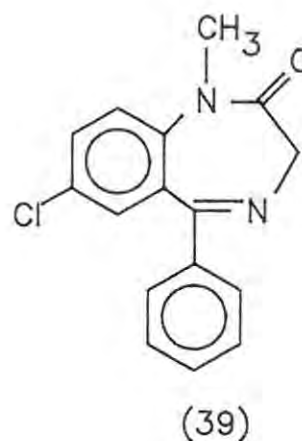
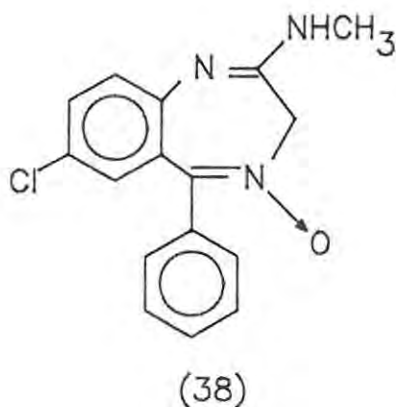

The mode of action of a drug, i.e. where it acts and how it acts, is of paramount importance in the development of new, more effective drugs with fewer side effects. When the benzodiazepines were first discovered, they were thought to be "wonder drugs", and were prescribed for many nervous disorders such as anxiety, depression, and many minor stress related ailments, e.g. insomnia. Little or nothing was known about their mode of action and their usefulness far outweighed any side effects. The benzodiazepines also appeared to be non-addictive, a property which made them ideal successors to the compounds which had previously been used to achieve the same effects on the nervous system, *viz.*, the opiates (e.g. morphine).⁴⁶ However, the complete elucidation of the mode of action of the benzodiazepines, some fifteen years after the discovery of chlordiazepoxide (38),⁴⁷ has called their widespread use into question. Therefore, the search for new antianxiety drugs with similar properties but less serious side effects continues.

The benzodiazepines work by binding to specific protein receptor sites in the brain which were discovered independently by researchers in Switzerland and Denmark.^{46,48} The benzodiazepine receptors form part of a complex unit which also contains receptors for a natural brain neurotransmitter, γ -aminobutyric acid (GABA). Some nerve cells secrete GABA, a universal inhibitor, when they associate with other nerve cells to form a synapse. GABA inhibits the transmission of a nerve impulse in neurons containing GABA-receptors and also indirectly inhibits the release of other neurotransmitters such as acetylcholine and dopamine. When GABA binds to the receptor, the latter changes shape, opening a chloride channel in the neuron membrane and allowing chloride ions to enter the nerve cell. This has the effect of increasing the ionic gradient between the inside of the cell and its surroundings (a condition known as hyperpolarisation) which in turn makes the cell resistant to excitation; it is more difficult for the hyperpolarised nerve cell to convey the nerve impulse, which can be regarded as a wave of depolarisation. This also means that GABA can inhibit nerve cells further down the line (a phenomenon called postsynaptic inhibition).

The GABA receptor can exist in two states, *viz.*, "high affinity", and "low affinity". Not all GABA receptors are in the "high affinity" state which favours GABA binding. The state of the GABA receptor is thought to be controlled by GABA-modulin, which is a protein in the membrane of the nerve cell. Once the benzodiazepine binds to its receptor, it inactivates GABA-modulin and allows the GABA receptor to assume its "high affinity" state, thereby making GABA binding possible (Figure 1).

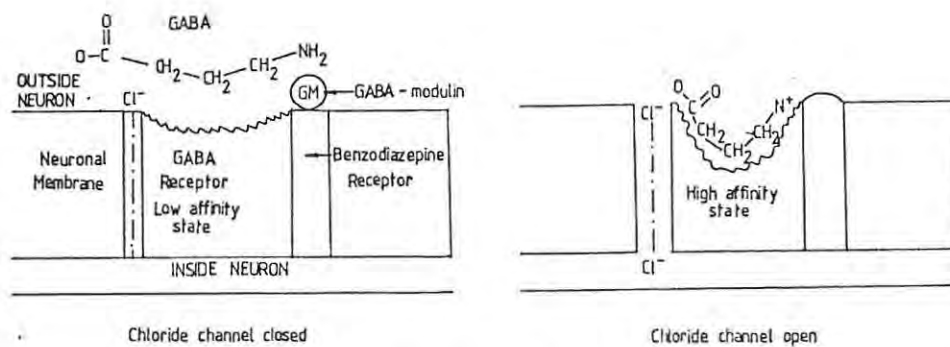
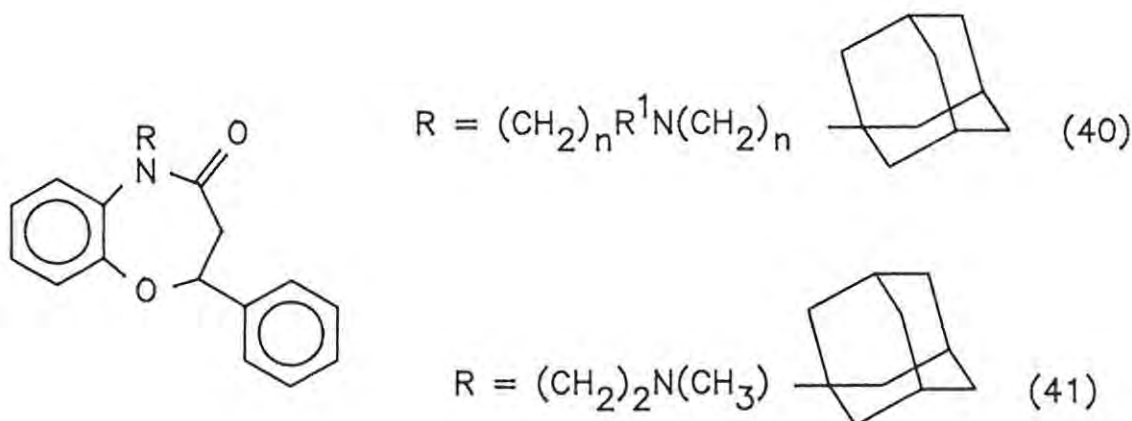

FIGURE 1

The benzoxazepinones have been tested for drug properties similar to those observed for the benzodiazepines. The 3-aryl derivatives (25) synthesized by Schenker^{33,34} were found to have antiphlogistic (anti-inflammatory) and analgesic (pain relieving) properties. The adamantyl derivatives of 1,5-benzoxazepin-4(5H)-ones [(40) and (41)], synthesized independently by Squibb⁴⁹ and Bernstein respectively,⁵⁰ have antidepressant properties.



Andreichikov *et al.*⁵¹ prepared some 1,5-benzoxazepin-3-ones such as (42) which have antimicrobial properties and Cale *et al.*⁵² discovered that the benzoxazepinones such as (43) have antihistaminic properties. Benzoxazepinones have also tested positive as spasmolytics and cataleptics,⁵³ and as sedative, anticonvulsive and antinarcosis agents.⁵⁴ Therefore they are an important class of compounds from a pharmacological viewpoint.

The tetrazoles (21), discovered by Misiti and Rimatori ²⁶ as a by-product of the Schmidt reaction of flavanones, are of particular interest as biologically active compounds since they are analogous to the recently marketed, first specific benzodiazepine antagonist, † Ro 15-1788 [Flumazenil, (45)]. Flumazenil (45) is a benzodiazepine itself, with an imidazole ring fused to the heterocyclic ring at the 1,2-position. It was discovered serendipitously by chemists searching for a novel benzodiazepine receptor ligand with a more selective activity profile than classic benzodiazepines. ⁴⁷ The idea of the fused imidazole ring arose from the fact that certain potent benzodiazepine receptor ligands also contain fused nitrogen heterocycles, *e.g.* the imidazole ring in Midazolam (46) and the triazole ring in Triazolam (47).

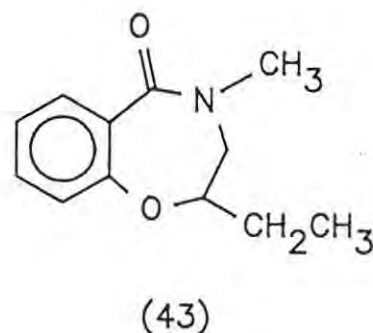
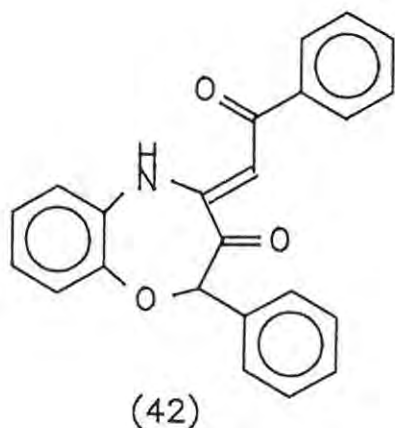

† Flumazenil competes with the benzodiazepines for the receptor sites, thereby blocking the action of the benzodiazepine and nullifying its effect.

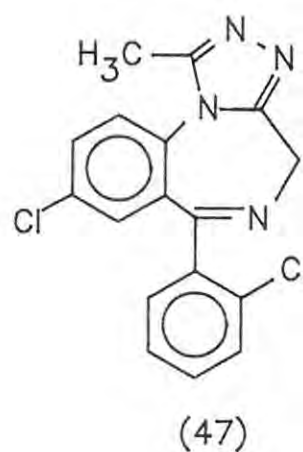
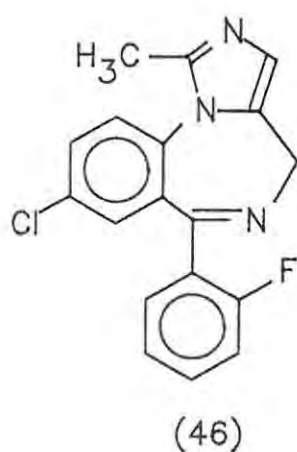
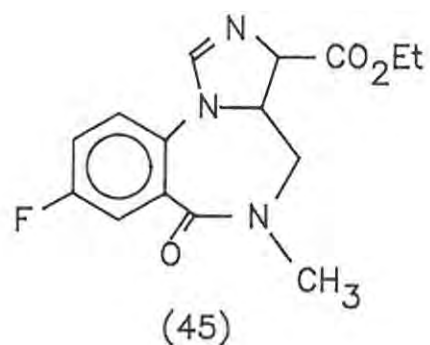
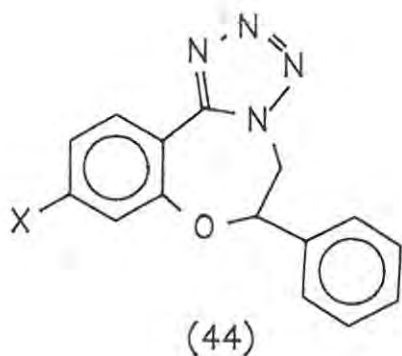

1.3. Aims of the current investigation

The primary aim of this research project was to synthesize a series of benzoxazepine analogues from simple starting materials, namely, the phenols, *via* the chalcones and the flavanones. The secondary aim of this investigation was the spectroscopic study (using ^1H and ^{13}C n.m.r. spectroscopy and mass spectrometry) of the compounds which were synthesized with a view to determining some of their physical properties.

2. DISCUSSION

4'-Substituted-2'-hydroxyacetophenones were prepared from simple phenolic starting materials (*cf.* Section 2.1.1.), which were then condensed with similarly substituted benzaldehydes to form the chalcones (*cf.* Section 2.1.2.). Cyclisation of chalcones afforded the flavanones and then ring expansion *via* the Schmidt reaction, afforded the benzoxazepines (*cf.* Section 2.1.3.). Mass spectrometric analyses of the benzoxazepines were performed and fragmentation patterns are proposed (*cf.* Section 2.2). Conformational analysis of the heterocyclic rings of the benzoxazepinones and tetrazoles was performed using molecular modelling and molecular mechanics, and ¹H n.m.r. techniques (*cf.* Section 2.3).

2.1. Synthesis of flavanones and benzoxazepinones

The general approach to the synthesis of the flavanones and the benzoxazepinones required in this study is outlined in Scheme 10. The initial precursors for these syntheses were the 3-substituted phenols (I). Acetylation and Fries rearrangement of these phenols (I) afforded the 4'-substituted-2'-hydroxyacetophenones (III), which were condensed with various aromatic aldehydes to give the substituted chalcones (IV). Cyclisation of these chalcones then gave the flavanones (V). Ring expansion to obtain the benzoxazepinones (VII) by two methods, *viz.*, the Beckmann and Schmidt rearrangements was envisaged. Subsequent oxidation of the ring expanded products was expected to afford the Δ^2 -substituted system.

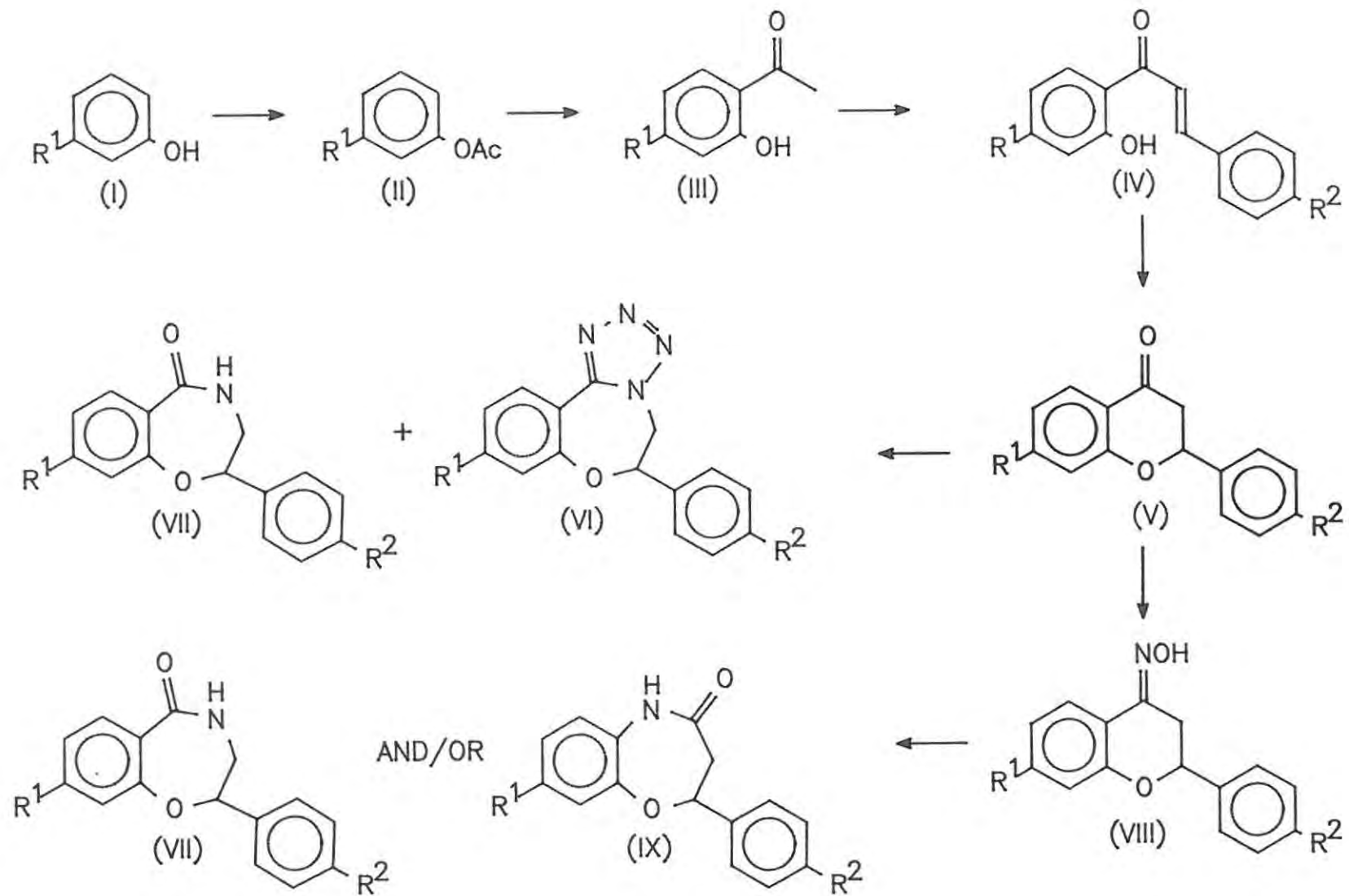

SCHEME 10

2.1.1. Preparation of the 2'-hydroxyacetophenones (54-56)

The esters (51-53) were produced in excellent yield (max. 96%) from the 3-substituted phenols (48-50) by the methods of Bryan *et al.*⁵⁵ (Scheme 11). These esters (51-53) were characterised by the absence of the phenolic hydroxyl peak in their respective ¹H n.m.r. spectra and by the appearance of a COMe signal at *ca.* δ 2.2.

Fries rearrangement to form the 2'-hydroxyacetophenones (54-56)⁵⁶ was achieved by heating the esters (51-53) in the presence of aluminium chloride. Reappearance of the phenolic hydroxyl signals below δ 12.0 in the n.m.r. spectra indicated formation of the 4'-substituted-2'-hydroxyacetophenones (54-56).

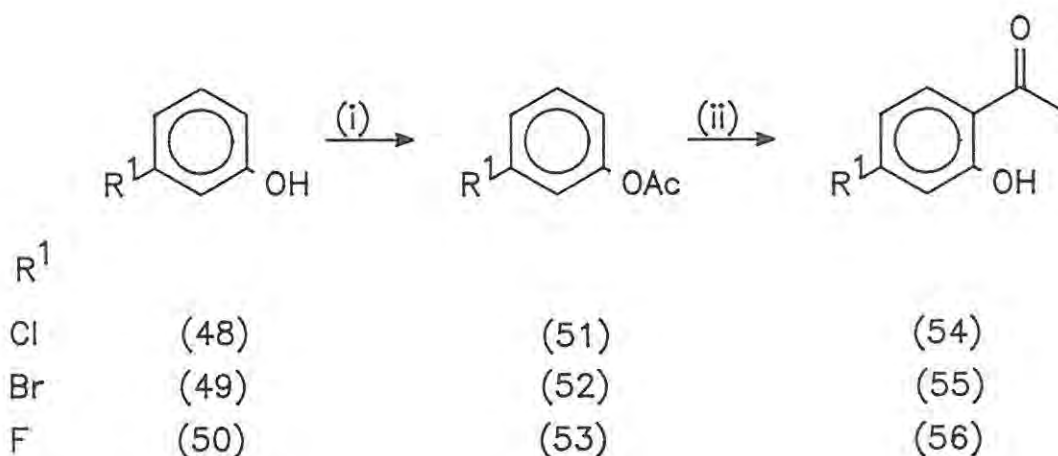

SCHEME 11

Reagents: (i) NaOH, Ac₂O, (ii) AlCl₃

2.1.2. Preparation of chalcones (15, 57–62) and flavanones (1, 63–68).

The preparation of the chalcones (15, 57–62) and flavanones (1, 63–68) was achieved using the methods of Chen and Chang⁵⁶ (Scheme 12). Condensation of the 4'-substituted-2'-hydroxyacetophenones (13, 54–56) with various 4-substituted benzaldehydes in the presence of strong base at 0°C afforded the chalcones (15, 57–62) in good yields (max. 89%). The chalcones (15, 57–62) are readily distinguished from the relatively colourless starting materials by their bright yellow colour. The chalcones have characteristic ¹H n.m.r. spectra (*cf.* Appendix 1), in which the aromatic and methylene signals occur in the region between δ 7.0 and 8.0. The phenolic hydroxyl proton resonates at very low field, usually below δ 12.0.

Phosphoric acid catalysed cyclisation of the chalcones (15, 57–62) afforded the flavanones (1, 63–68) in moderate yields. Varying the concentration of the phosphoric acid had very little effect on the yields of the flavanones (1, 63–68) obtained in these reactions. For example, in the case of compound (67), increasing the acid concentration from 0.67 mol.L⁻¹ to 2.5 mol.L⁻¹ only increased the overall yield of the cyclisation reaction by 7% (from 20 to 27%).

In the literature procedure for the synthesis of flavanones,⁵⁶ Chen and Chang concentrated the reaction mixture *in vacuo* and allowed the product to crystallise out of the concentrated solution. Repeated recrystallisation afforded the pure flavanones. However, in the present study, it was found that this method was unsatisfactory, resulting in poor yields of relatively impure flavanones. Therefore, concentration of the reaction mixture was followed by extraction with ethyl acetate and flash chromatography⁵⁷ (elution with benzene or toluene), to afford the pure flavanones. In most cases, the

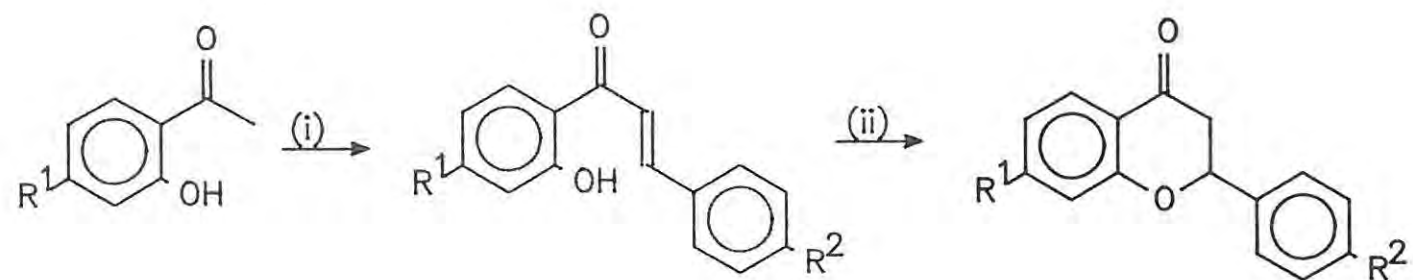

R ¹			R ¹	R ²	
H	(13)	(15)	H	H	(1)
Cl	(54)	(57)	Cl	H	(64)
Br	(55)	(58)	Br	H	(63)
F	(56)	(59)	F	H	(65)
H	(13)	(60)	H	Cl	(67)
H	(13)	(61)	H	Br	(66)
H	(13)	(62)	H	F	(68)

SCHEME 12

Reagents: (i) KOH, 4-R²ArCHO (R² = H, Cl, Br, F), (ii) H₃PO₄

Cpd.	R ¹	R ²	C-2	C-3	C-4	C-4a	C-5	C-6	C-7	C-8	C-8a	C-1'	C-2' & C-6'	C-3' & C-5'	C-4'
1	H	H	79.41	44.48	191.62	120.81	126.88	121.44	135.97	117.96	161.37	138.63	126.00	128.67	128.56
63	Br	H	79.92	44.30	190.98	119.82	125.23	128.22	130.52	121.32	161.64	138.19	126.07	128.86	128.86
64	Cl	H	79.91	44.24	190.69	119.46	122.35	128.21	141.94	118.22	161.76	138.19	126.06	128.83	128.83
65	F	H	80.00	44.05	190.19	117.79	129.44	109.86	167.39	104.74	163.00	138.19	126.00	128.74	128.74
66	H	Br	78.78	44.48	191.34	120.87	127.04	121.77	136.22	118.03	161.23	137.77	127.75	131.95	122.65
67	H	Cl	78.67	44.42	191.25	120.81	126.96	121.68	136.12	117.96	161.17	137.22	127.42	128.91	134.42
68	H	F	78.76	44.48	191.36	120.79	126.91	121.58	136.05	117.93	161.66	134.54	127.91	115.62	162.43

Table 1
¹³C n.m.r. chemical shift data (ppm) of the flavanones

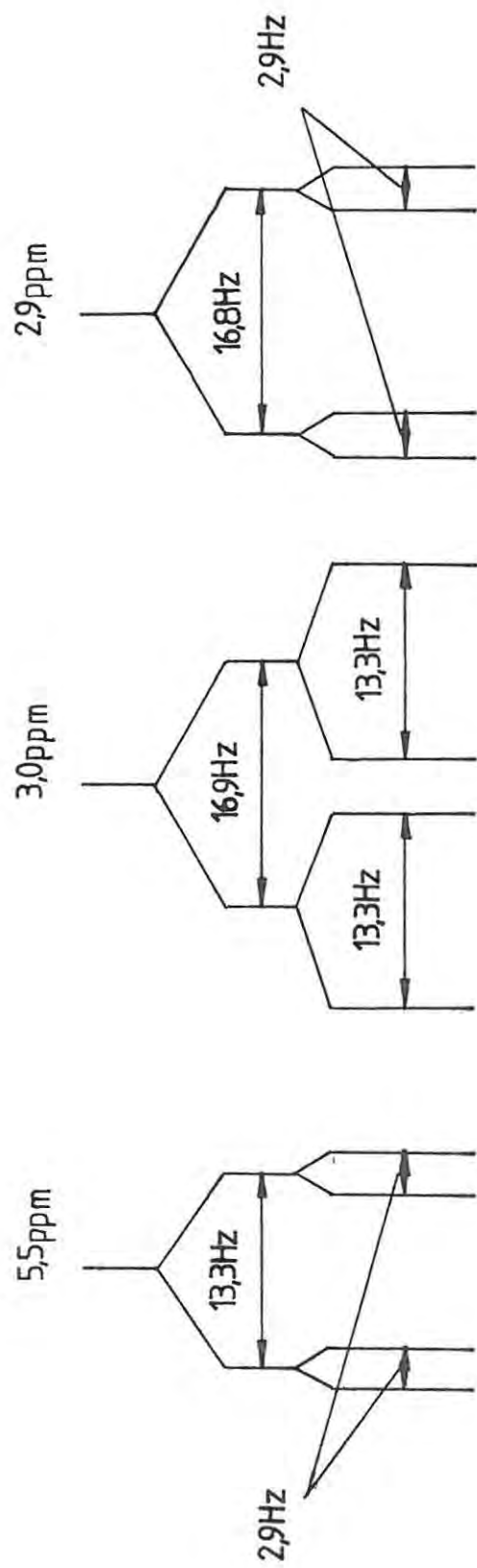

FIGURE 2

unreacted chalcone was recovered in high purity.

The flavanones were identified by their ^1H and ^{13}C n.m.r spectra (*cf.* Table 1).^{57,59} In the proton spectra, two double doublets at *ca.* δ 2.9 and 3.0 were observed, corresponding to the two protons attached to C-3. A third double doublet at *ca.* δ 5.0, corresponding to the proton attached to C-2, was also observed. The splitting patterns of these signals were analysed and the observed coupling constants were consistent with the flavanone structure (*cf.* Figure 2).

2.1.3. Preparation of the benzoxazepinones

The benzoxazepinones required in this study, were prepared by the Schmidt reaction. However, attempts to prepare these compounds via the Beckmann rearrangement were not successful.

2.1.3.1. The attempted Beckmann rearrangement of flavanone oxime (73).

The rearrangement of ketoximes to form amides was discovered by Ernst Beckmann in 1886 and is known as the Beckmann rearrangement.⁶⁰ The history, mechanism, and applications of this reaction are well documented and it was thought, at the outset, that the Beckmann rearrangement would be a simple way of transforming flavanones, via their oximes, into benzoxazepinones. Many reagents have been used to effect this transformation, two of the more common examples being sulphuric acid and phosphorus pentachloride. More recently, hexamethylphosphoric triamide⁶¹ and polyphosphoric acid^{62,63} have also been used.

Pearson and Stone ⁶⁴ studied the mechanism of the rearrangement of acetophenone oximes in polyphosphoric acid and found that the reactions occurred 12 to 35 times more rapidly than in sulphuric acid. Huckle *et al.* ²⁰ used polyphosphoric acid to transform chromanone oxime (69) to 2,3-dihydro-1,4-benzoxazepin-5(4H)-one (70) (Scheme 13).[‡] It is interesting to note that they did not isolate or detect any 2,3-dihydro-1,5-benzoxazepin-4(5H)-one [(17), R = H].

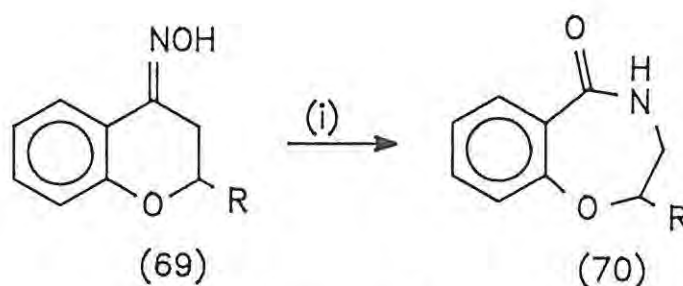

SCHEME 13

Reagent: (i) Polyphosphoric acid

Therefore, it was decided to attempt a Beckmann rearrangement on flavanone oxime (73) using polyphosphoric acid. Flavanone oxime (73) ⁶⁶ was synthesized by boiling an alcoholic solution of flavanone (1), hydroxylamine hydrochloride, and potassium carbonate under reflux for 6 hours (Scheme 14). A mass spectrum of the product revealed the correct molecular ion peak for the oxime (M^+ , 239) and analysis of the fragmentation pattern of the compound indicated similar fragmentation to the flavanones. The ¹H n.m.r. spectrum for the oxime (73) contained an NOH signal at δ 11.2, while the C=N signal in the ¹³C n.m.r. spectrum is shifted upfield relative to the C=O signal in flavanone (1) (from δ_c 191.62 to 155.56).

[‡] Polyphosphoric acid proved to be ineffectual in transforming xanthone oxime (71) to dibenz[b,f][1,4]oxazepin-11(10H)-one (72) (scheme 15).⁶⁵

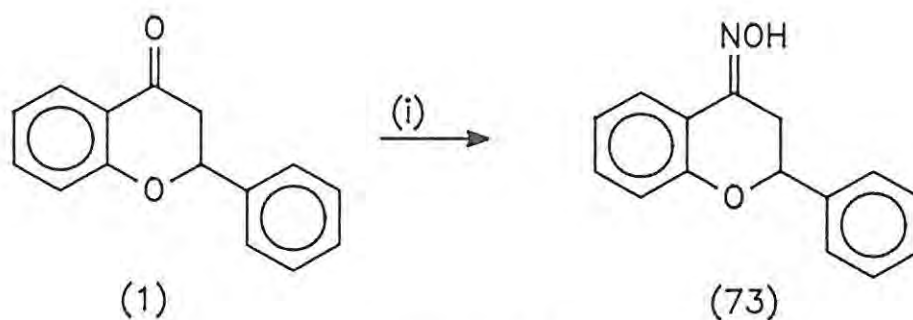

SCHEME 14

Reagents: (i) $\text{NH}_2\text{OH}\cdot\text{HCl}$, K_2CO_3 , EtOH

In the formation of the oxime, two different configurations are possible, *viz.*, the (*Z*)- and (*E*)- oximes (*cf.* Figure 3a). The configuration must have some bearing on the nature and proportion of the products formed in the subsequent Beckmann rearrangement reaction. With this in mind, it was decided to determine the exact configuration of flavanone oxime (73) by means of x-ray crystallography (*cf.* Appendix 3). Good oxime (73) crystals were obtained from *n*-propanol and preliminary x-ray studies on a Stoe Damstadt Reciprocal Lattice Explorer showed the space group of the crystals to be $\text{P}2_1/\text{n}$. Crystallographic reflection data were obtained on an Enraf Nonius CAD 4 diffractometer and refinement of these data on the CDC Cyber mainframe revealed a structure with a final R-factor of 0.0831 (Figure 3b). No evidence of hydrogen bonding could be detected as shown in the packing diagram below (Figure 3c). The configuration of the oxime (73) was found to be or (*E*).

The procedure of Huckle *et al.*²⁰ was followed for the Beckmann reaction on flavanone oxime (73) and involved heating an intimate mixture of flavanone oxime (73) and polyphosphoric acid at 130–135°C for 15 minutes. Workup afforded a crude crystalline product which, on t.l.c. analysis, proved to be mostly starting material (73) and a small amount of flavanone (1). The

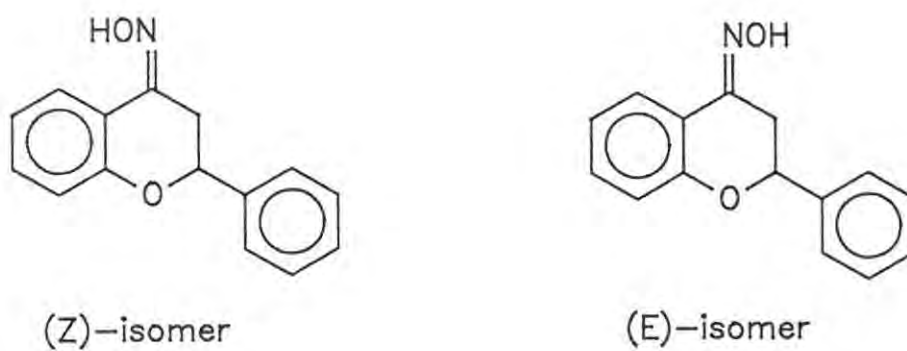

FIGURE 3a

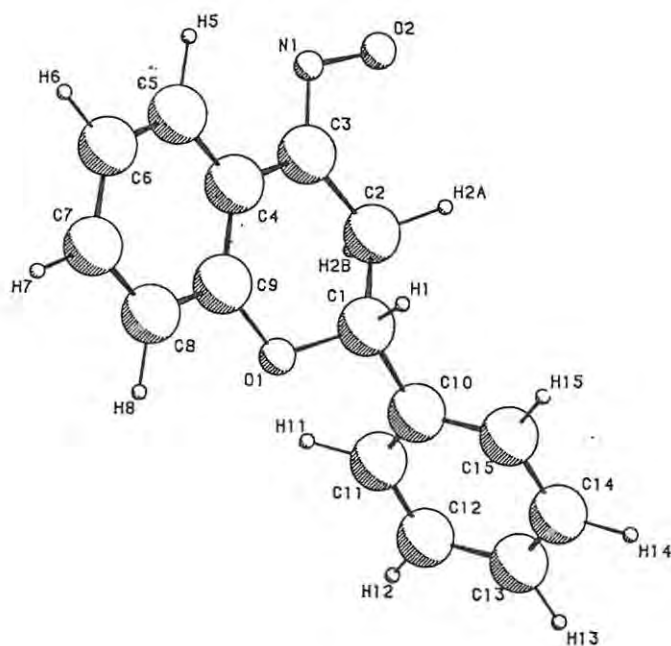

FIGURE 3b

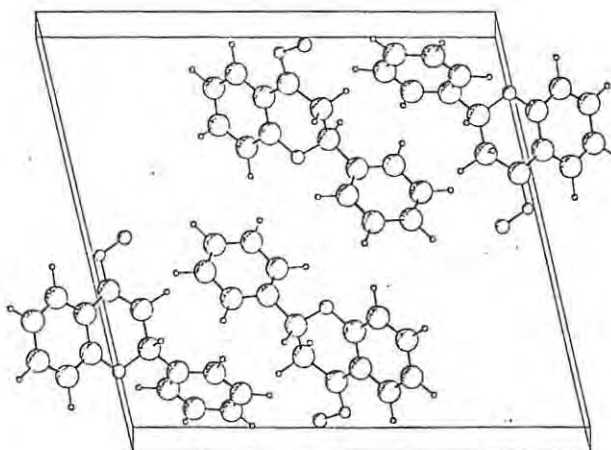
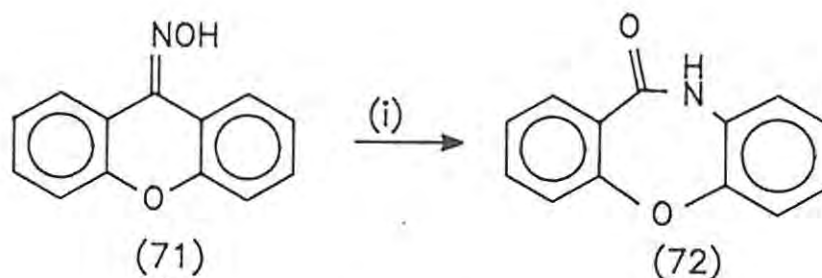

FIGURE 3c

reaction was repeated using fresh starting material (73), and heating was continued for 1 hour, but the same result was obtained.

Phosphorus pentachloride has been described ⁶⁰ as 'the most generally applicable and the most valuable reagent' for causing the Beckmann transformation. Nagarajan *et al* ⁶⁵ used phosphorus pentachloride to convert xanthone oxime (71) to the corresponding dibenz[b,f],[1,4]-oxazepin-11(10H)-one (72) (Scheme 15).



SCHEME 15

Reagent: (i) PCl_5

An attempt to rearrange flavanone oxime (73) by the method of Blatt *et al* ⁶⁷ showed at least seven products on t.l.c. analysis. Flash chromatography [elution with hexane-ethyl acetate (1:1)] was used in an unsuccessful attempt to purify the major components.

The results of these attempted Beckmann rearrangements appear to indicate that this reaction does not present a viable method for obtaining the benzoxazepinones from flavanone oximes.

2.1.3.2. The Schmidt rearrangement.

The Schmidt reaction, discovered in 1923, is a means of converting ketones to amides under the influence of hydrazoic acid in the presence of an acid catalyst, for example sulphuric acid.⁶⁸ This reaction has been used previously to convert chroman-4-one (6) to 2,3-dihydro-1,4-benzoxazepin-5(4H)-one [(18), R = H] (Scheme 16).^{21,23}

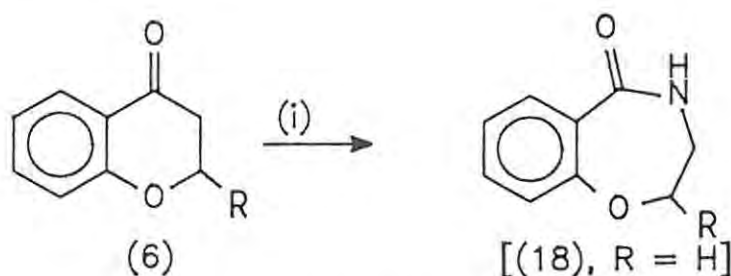

SCHEME 16

Reagents: (i) NaN_3 , H_2SO_4

Misiti and Rimatori²⁸ showed that the reaction of flavanone (1) with sodium azide and sulphuric acid produced 2,3-dihydro-2-phenyl-1,4-benzoxazepin-5(4H)-one [(18), R = Ph]. More recently, it has been demonstrated that the reaction of flavanone (1) with trimethylsilyl azide in trifluoroacetic acid also produced compound [(18), R = Ph] and an interesting minor product, *viz.*, 2,3-dihydro-2-phenyl-4H-tetrazolo[1,5-d]-1,4-benzoxazepine (21).³⁰ Therefore, this method was expected to provide direct access to all of the benzoxazepinones required for this study, and in fact, eight were prepared in this way (Scheme 17). The by-product tetrazoles were also isolated and purified.

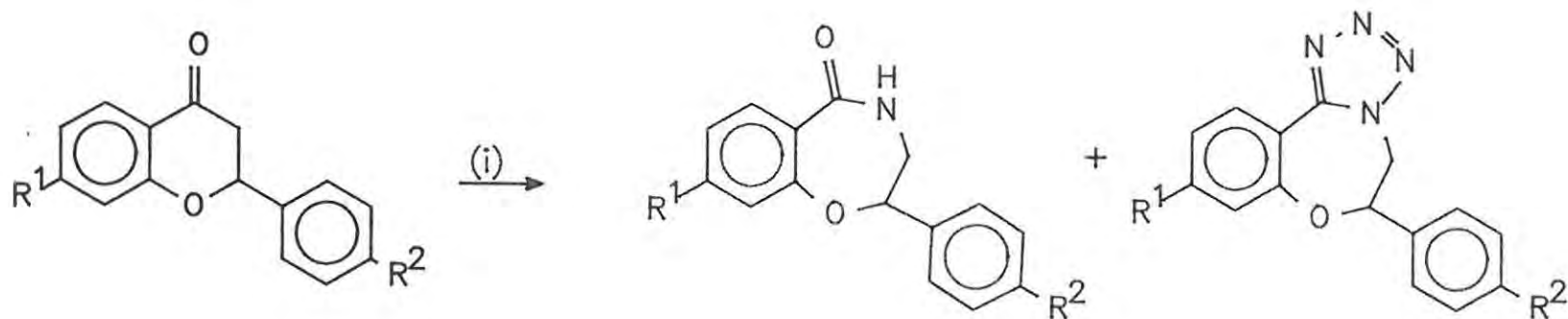

R ¹	R ²			
H	H	(1)	[(18), R = Ph]	(21)
Cl	H	(64)	(76)	(77)
Br	H	(63)	(74)	(75)
F	H	(65)	(78)	(79)
H	Cl	(67)	(82)	(83)
H	Br	(66)	(80)	(81)
H	F	(68)	(84)	(85)

SCHEME 17

Reagents: (i) $(\text{CH}_3)_3\text{SiN}_3$, F_3CCOOH

The interesting point to note in the above discussion on the early work concerning ring-expansion of some benzopyran-4-one systems is that only one amide product is reported, *viz.*, 1,4-benzoxazepin-5(4H)-one. Much work has been done in elucidating the mechanism of this important reaction, and although Schmidt, himself, proposed a mechanism, this was later proved to be incorrect. The more modern hypotheses concerning the mechanism of this rearrangement have been reviewed ^{68,69,70,71}.

In the generally accepted mechanism (Scheme 18), the carbonyl group of the ketone substrate is attacked by hydrazoic acid to form the azidohydrin intermediate, which dehydrates to the iminodiazonium ion (86). The latter can isomerise, permitting access to both the (*E*)- and (*Z*)-configurations and resulting in both isomeric amides being formed. The ratio of the amide products is determined by the relative proportions of (*E*)- and (*Z*)- isomers of the iminodiazonium ion in the reaction mixture, which, in turn, is influenced by the reaction conditions and steric and electronic factors. Migration of the substituent *anti* to the diazo-group of the iminodiazonium ion, is accompanied by the loss of nitrogen (N₂) to form the iminocarbonium ion (87), which then reacts with water (or any other nucleophilic agent) †† forming the reaction products [(88a) and/or (88b)].

Smith and Horwitz, ⁷¹ in a study of alkylphenylketones, discovered that steric factors have a greater influence than electronic factors on the outcome of the Schmidt reaction, by shifting the equilibrium (Scheme 18) in favour of the configuration in which the more bulky substituent (in this case, the phenyl

†† Tetrazoles and other by-products (*e.g.* aminotetrazoles and ureas) may be formed depending on the reaction conditions, and the nature of the substrate, *etc.* Tetrazoles form when the iminocarbonium ion (87) reacts with excess hydrazoic acid.

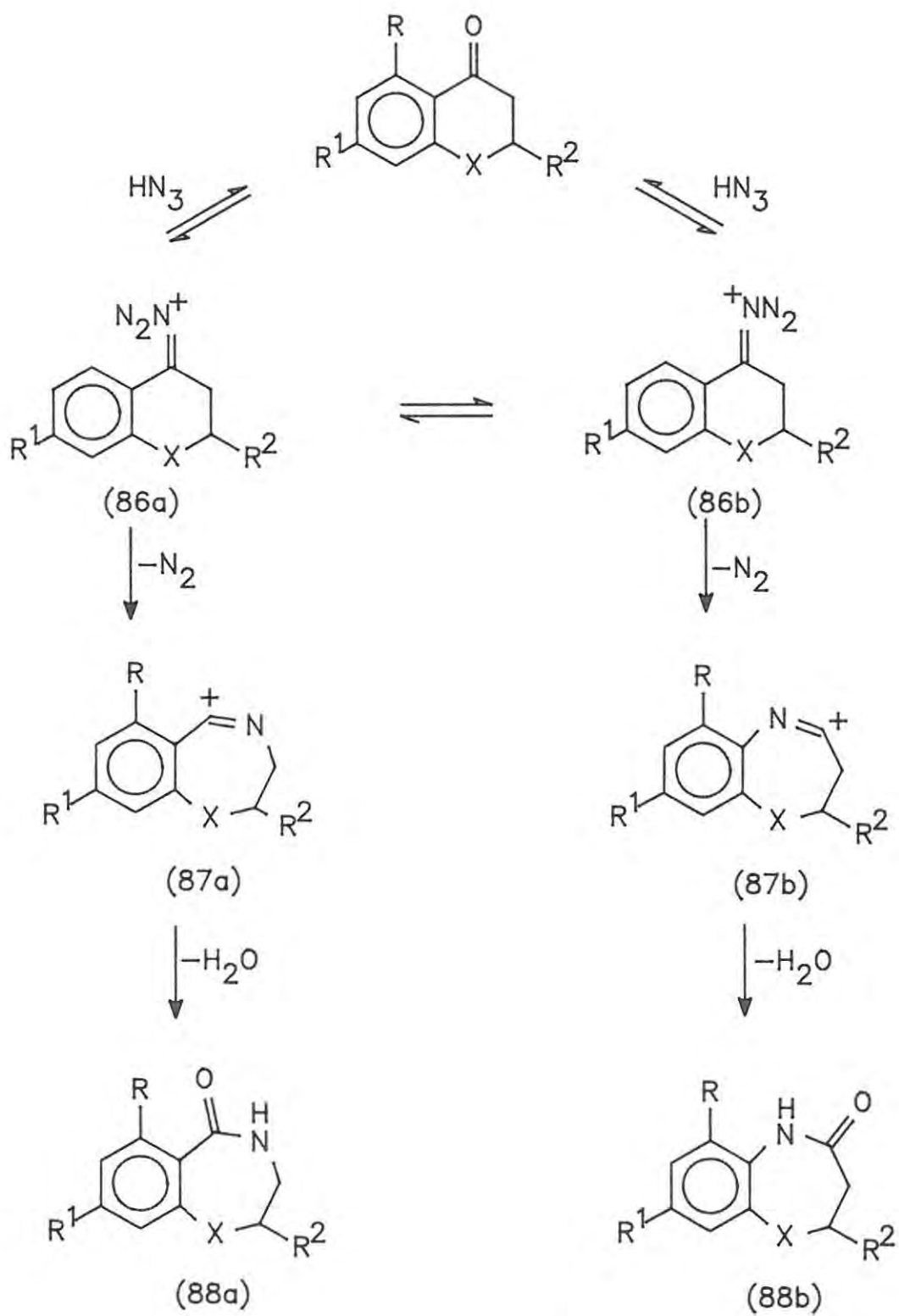

SCHEME 18

group) is *anti* to the diazo group of the iminodiazonium ion. With alkyl substituents of relatively small steric bulk (*e.g.* CH₃), aryl migration predominates with the formation of a benzanilide product. When the alkyl substituents are sterically larger [*e.g.* CH(CH₃)₂], alkyl migration becomes more favourable and benzamide products are formed in relatively larger quantities.

Therefore, in the Schmidt rearrangement of benzopyran-4-ones, both 1,5-benzoxazepin-4(5H)- and 1,4-benzoxazepin-5(4H)-ones might be expected to form. However, in previous work, and in this study, only the 1,4-isomer was observed to form in the Schmidt reaction on flavanones, and closer investigation of this apparent anomaly is warranted.

Lockhart *et al.*^{20,21} performed an in-depth study on the Schmidt reaction of chroman-4-ones and their tetralone analogues. As mentioned above, the steric and electronic factors have a profound influence on the outcome of this rearrangement. With unsubstituted tetralones and 5-substituted chromanones, steric factors dominate and benzanilide products are formed. However, chroman-4-one (6) and 6-methoxy-1-tetralone form benzamide products, suggesting that the electron donating properties of the ether substituents at the *ortho*- and *para*-positions relative to the ketone group, must influence the outcome of the reaction. Thus, delocalisation of an oxygen lone pair, effectively increases the double bond character of bond (a), thereby, decreasing the tendency of the benzannulated compounds to undergo aryl migration (Scheme 19).

It was also discovered^{19,27} that 2,3-dihydro-1,5-benzoxazepin-4(5H)-one is completely hydrolysed by acid within 20 hours, while no hydrolysis of the

1,4-isomer was observed after 18 days. Therefore, even if the 1,5-isomer was formed, it would have been hydrolysed back to chroman-4-one under the reaction conditions used for the rearrangement.

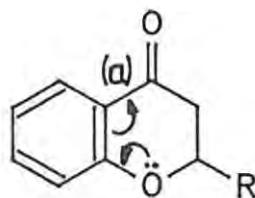

SCHEME 19

Bhalerao and Thyagarajan ²³ also studied the Schmidt reaction on substituted chroman-4-ones and measured the ratios of 1,4- and 1,5-benzoxazepinones formed. If the substituent at the 5-position in chroman-4-one is large, more 1,5-isomer is formed. With 7-alkylchroman-4-ones, only the 1,4-isomer was formed, which suggested that electronic effects prevailed, in agreement with the findings of Lockhart *et al.* above. Based on these findings, two possible pathways for the formation of benzoxazepinones were postulated. When electronic factors dominate, the 'normal' pathway is followed and products are formed *via* the iminodiazonium ion. However, when steric factors dominate, as in the case of 5-substituted chroman-4-ones, the products are thought to be formed directly from the azidohydrin intermediate.

Therefore, in summary, when substituents are present at the 5-position in benzopyran-4-ones, steric effects predominate over electronic effects, and aryl migration, to form 1,5-benzoxazepin-4(5H)-ones, may be expected. In the absence of a 5-substituent, electronic effects determine the outcome of the Schmidt reaction, and alkyl migration, affording 1,4-benzoxazepin-5(4H)-ones

may be expected. This would explain why only the 1,4-isomers are formed in the case of unsubstituted and 7-substituted flavanones. Tetrazoles, resulting from the reaction of the iminocarbonium ion with excess hydrazoic acid may also be expected from the Schmidt reaction of these flavanones.

Isolation of the products in the present study, was achieved using flash chromatography. T.l.c. analysis showed that the starting material in each case moved further in toluene or benzene than the two products. In hexane-ethyl acetate (1:1), the starting material and the tetrazole moved further and the benzoxazepinone moved slowly as illustrated in Figure 4.

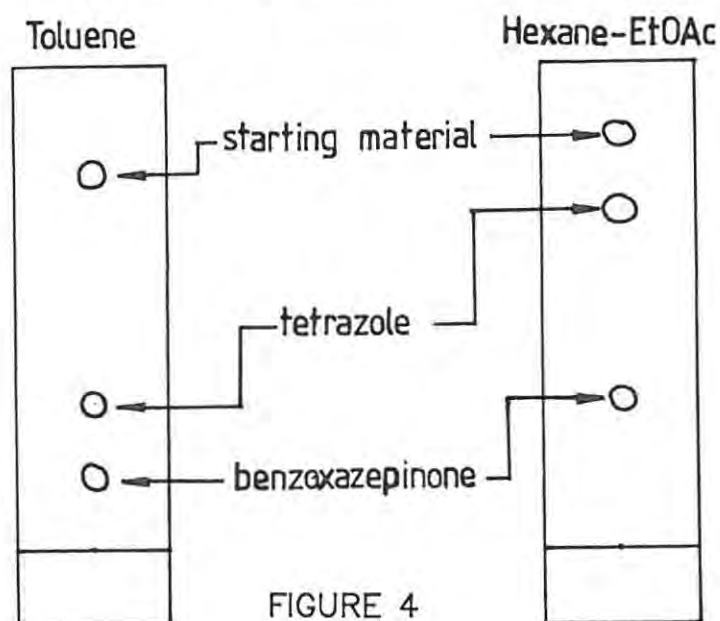

FIGURE 4

Application of these observations permitted convenient separation of the three components. Thus, elution on a flash column with toluene removed the starting material and then elution with hexane-ethyl acetate (1:1) separated the two products, which were then recrystallised from ethanol to afford the pure benzoxazepinone and tetrazole.

Several techniques were employed for the identification of the ring expanded products. Mass spectrometry was used to confirm the molecular masses of the

compounds. [Many of the major peaks in the mass spectra of the compounds were further investigated by means of high resolution mass spectrometry with a view to analysing their fragmentation patterns (*cf.* Section 2.2)]. High field ^{13}C and ^1H n.m.r. as well as elemental analysis †† were used.

Analysis of the ^1H n.m.r. spectra (*cf.* Appendix 1) of the benzoxazepinones, synthesized in this study, revealed the following general features.

1. The aromatic proton signals occurred in the region between δ 7.0 and 8.0.

2. A broad amide proton signal which could be detected in most cases occurred above δ 7.0, sometimes falling within the aromatic proton region. At high field (500MHz), the amide proton signal appeared as a partially resolved multiplet, consistent with coupling to the adjacent 3-H nuclei.

3. Two multiplets (ddd) at *ca.* δ 3.5 and δ 3.6, and a double doublet at *ca.* δ 5.4 were observed, corresponding to the 3-H and 2-H nuclei respectively. In some cases, these signals were not fully resolved and the coupling constants could not be accurately calculated. However, in the case of 2,3-dihydro-2-phenyl-1,4-benzoxazepin-5(4H)-one [(18), R = Ph], the splitting pattern was fully resolved and analysed (*cf.* Figure 5). The coupling constants obtained in this way were used with the Karplus equations to determine the conformation of the heterocyclic ring (*cf.* Section 2.3.1).

The ^{13}C n.m.r. spectra of the benzoxazepinones were also analysed ⁷² and the results for all the compounds are summarised in Table 2. A comparison between the chemical shift data of the flavanones and the benzoxazepinones

†† In some instances, where the desired purity of the compounds could not be achieved, high resolution mass spectrometry was used to determine the accurate M^+ peak and this was then compared to the calculated accurate M^+ value.

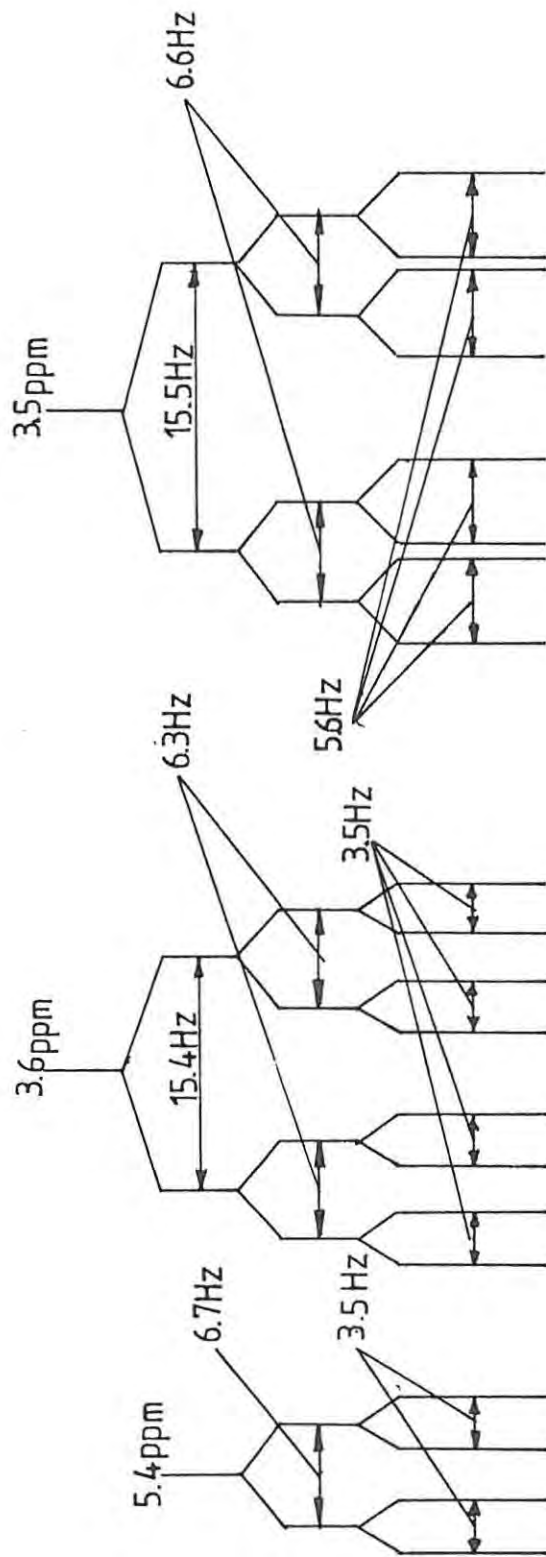

FIGURE 5

Cpd.	R ¹	R ²	C-2	C-3	C-5	C-5a	C-6	C-7	C-8	C-9	C-9a	C-1'	C-2' & C-6'	C-3' C-5'	C-4'
18	H	H	85.87	46.08	171.17	125.73	130.75	123.41	133.12	122.29	154.41	138.93	126.15	128.27	128.27
74	Br	H	85.97	46.43	170.01	132.90	132.51	126.67	127.02	125.30	155.25	138.47	126.12	128.73	128.64
76	Cl	H	85.87	47.06	169.59	126.33	132.50	123.87	139.59	122.33	155.71	138.03	126.05	128.77	128.77
78	F	H	85.96	46.51	170.02	121.15	133.31	110.97	165.60	109.15	156.39	138.55	126.13	128.72	128.62
80	H	Br	85.13	45.96	171.16	125.90	130.84	123.89	133.35	122.29	154.22	138.01	127.97	131.71	122.39
82	H	Cl	84.78	46.77	170.98	125.22	131.05	123.90	134.08	122.33	154.76	137.00	127.58	128.87	134.45

Table 2

¹³C n.m.r. chemical shift data (ppm) of the benzoxazepinones

revealed the following general trends. The chemical shift values of the carbons of the 2-phenyl substituent were unaffected by the ring expansion and agreed to within a few tenths of a ppm. The amide carbonyl carbon of the benzoxazepinones was shifted upfield by approximately 21 ppm relative to the carbonyl carbon of the flavanones. Carbons C-8 and C-9a in the benzoxazepinones are more shielded than the corresponding carbons of the flavanone system, *viz.*, C-7 and C-8a and all other carbons of the benzoxazepinones, not mentioned thus far, were shifted downfield relative to those of the flavanones.

Analysis of the ^1H n.m.r. spectra of the tetrazoles revealed the following general trends.

1. The aromatic proton signals occurred in the region between δ 7.0 and 8.5. As expected, no amide proton signal was observed, indicating that the compound was not a benzoxazepinone;

2. A double doublet at *ca* δ 4.8 and another at *ca.* δ 5.1 corresponding to the protons attached to C-3 was observed.

- 3 A double doublet at *ca.* δ 5.2 corresponding to the proton attached to C-2 was detected. †††

The splitting patterns of the tetrazoles are simpler than those of the corresponding benzoxazepinones due to the absence of the amide proton. The coupling constants obtained from analysis of these splitting patterns have also been used to determine the conformation of the heterocyclic ring of the tetrazoles (Figure 6). The ^{13}C n.m.r. spectra of the tetrazoles were also

††† In the case of 2,3-dihydro-2-phenyl-tetrazolo[1,5-d]-1,4-benzoxazepine (21), only one double doublet at δ 4.7 was observed, corresponding to one of the protons attached to C-3. The remaining two protons attached to C-2 and C-3 produced doublets at δ 5.0 and 5.2 respectively.

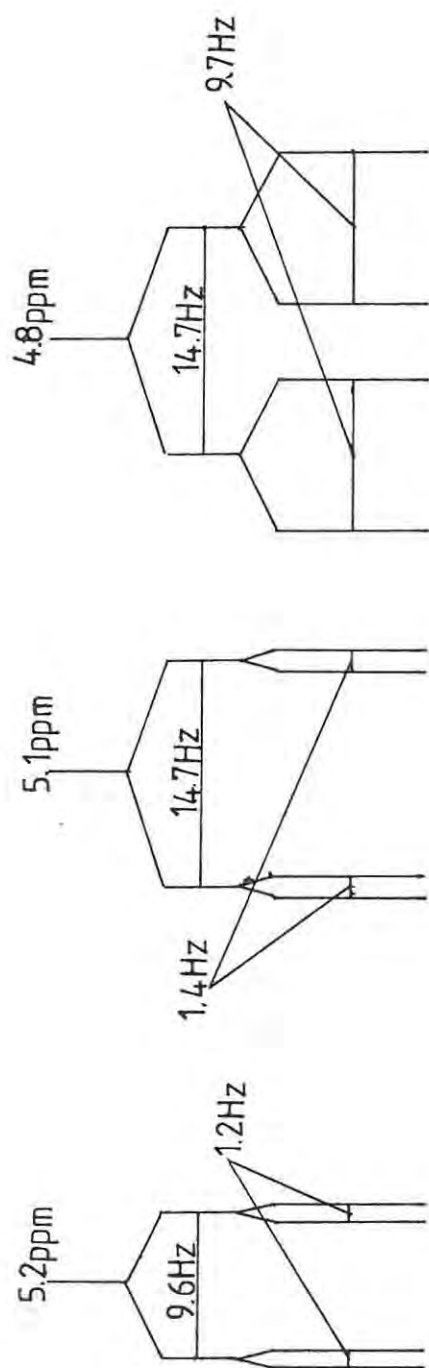

FIGURE 6

Cpd.	R ¹	R ²	C-2	C-3	C-5	C-5a	C-6	C-7	C-8	C-9	C-9a	C-1'	C-2' & C-6'	C-3' C-5'	C-4'
21	H	H	78.71	55.98	156.64	112.82	130.13	123.75	133.03	121.34	151.69	136.22	125.93	128.88	129.02
75	Br	H	79.24	55.98	156.98	111.97	131.28	127.35	126.85	124.73	151.32	135.79	126.02	129.13	129.40
77	Cl	H	79.30	56.09	156.99	111.49	131.28	124.54	138.77	121.74	151.21	135.68	125.94	129.12	129.42
79	F	H	79.30	55.59	158.2	—	132.2	111.9	165.2	108.6	151.3	135.9	126.0	129.1	129.4
81	H	Br	78.34	56.04	156.43	112.85	130.44	124.19	133.31	121.42	151.80	135.16	127.64	132.25	123.88
83	H	Cl	78.29	56.11	156.44	112.85	130.45	124.17	133.30	121.42	151.80	135.24	127.36	129.29	134.66

Table 3
¹³C n.m.r. chemical shift data (ppm) of the tetrazoles

analysed and the results are summarised in Table 3.

The ^{13}C chemical shift values of tetrazoles showed the following general trends. C-3', C-4' and C-5' were shifted downfield relative to the equivalent carbons of flavanones and benzoxazepinones. δ values of C-2' and C-6' were essentially unchanged from those observed in flavanones and benzoxazepinones, while C-3 and C-7 were deshielded relative to the equivalent carbons in flavanones and benzoxazepinones. All the carbons of tetrazoles, not mentioned thus far, were shifted upfield relative to the equivalent carbons of flavanones and benzoxazepinones, except for C-6, which appears to be more shielded than C-6 in the benzoxazepinone case, and deshielded relative to C-5 of the corresponding flavanone.

2.1.4. Further reactions of the benzoxazepinone system

The heterocyclic ring system of the benzodiazepines contains a high density of π - and lone pair donor electrons due to the presence of the electron rich nitrogens and the unsaturation at the 4-position [*e.g.* (39)].

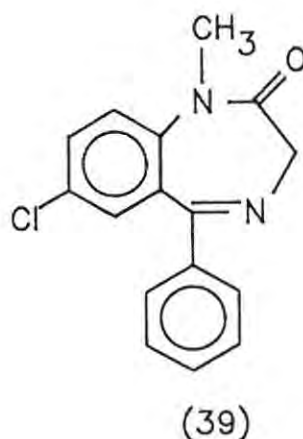

This encouraged the investigation of introducing unsaturation into the benzoxazepinone heterocycle in this study. The synthetic challenge was to introduce a double bond at the 2-position in the benzoxazepinones and two methods of doing this were explored, *viz.*, bromination–dehydrobromination and oxidative dehydrogenation. Closer inspection of the benzoxazepinone system highlighted the possibility that any reaction involving the removal of a hydrogen atom could tend to favour abstraction of the amide group and result in mixtures of products. To prevent this happening, protection of the nitrogen was thought to be necessary.

The choice of a protecting group was influenced by various factors. Firstly, the protecting group had to be easy to place and then displace at a later stage. Another requirement was that the protecting group, once in place, should have no acidic protons, which might interfere with subsequent reactions. Therefore, an acyl group with no α -hydrogens was thought to be suitable for the protection of the amide proton, pivaloyl or benzoyl groups being obvious choices. The benzoyl group was, in fact, used because benzoyl chloride was readily available and relatively easy to handle.

The base used for the amide proton abstraction in the acylation step also had to be carefully chosen, as a nucleophilic base could attack the amide carbonyl carbon and open the ring system (Scheme 20).

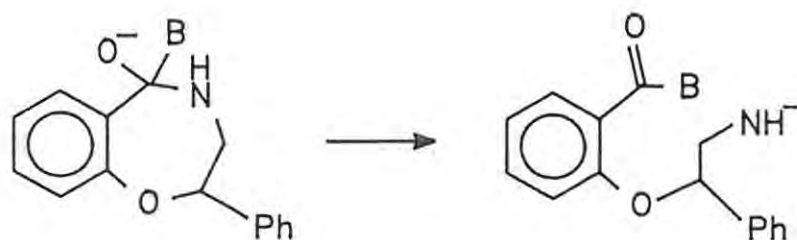

SCHEME 20

B = Nucleophilic base

Lithium diisopropylamide (LDA) was chosen due to its low nucleophilicity and was generated *in situ* at low temperature (-30°C), under a nitrogen atmosphere, by the addition of butyllithium to diisopropylamine. The benzoxazepinone [(18), R = Ph] was then added [at lower temperature (-78°C)], followed by the addition of benzoyl chloride (Scheme 21)). Work-up and recrystallisation from ethyl acetate afforded the imide (89) as large colourless prisms. The identity of the known imide (89) was confirmed by mass spectrometry, and ^1H n.m.r. spectroscopy.

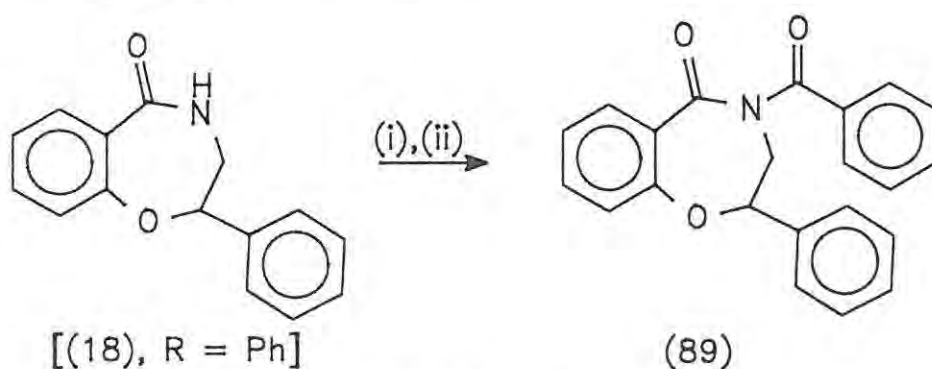

SCHEME 21

Reagents: (i) LDA, (ii) $\text{C}_6\text{H}_5\text{COCl}$

The first attempt at introducing unsaturation into the heterocyclic ring between C-2 and C-3 involved a bromination-dehydrobromination sequence. Here, the protected benzoxazepinone was first brominated at the 2-position by abstraction of the benzylic proton (again, with a non-nucleophilic base, *e.g.* LDA) to form the benzylic anion, followed by the addition of a bromine electrophile, using, for example Br_2 or *N*-bromosuccinimide (NBS) (Scheme 22). This method was attempted several times without success. Later, it was established that the first step, *viz.*, proton abstraction was not accomplished. This fact was determined by quenching an aliquot of the reaction mixture with D_2O and running a ^1H n.m.r. spectrum of the resulting solution. If the proton had been abstracted then the quenching process would have been expected to

deuteriate the 2-position and the 2-H signal would not have been detected in the spectrum. This was not the case, however, and the 2-H nucleus was still observed to be present in the compound (the 2-H signal integrated for one proton).

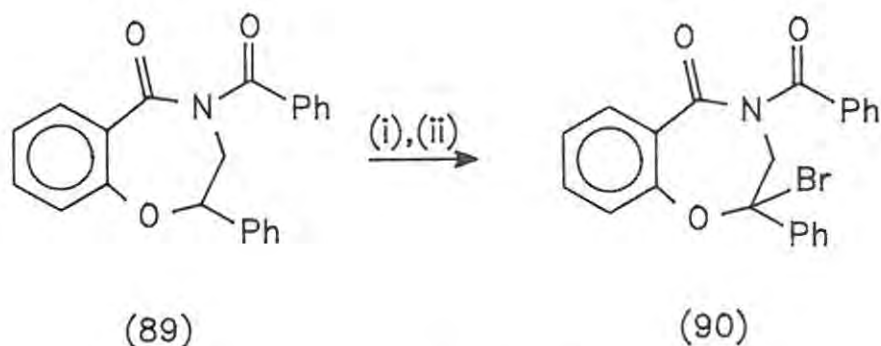

SCHEME 22

Reagents: (i) LDA, (ii) Br₂ or NBS

A second method of introducing the double bond by means of an oxidative dehydrogenation reaction using selenium dioxide was envisaged. Selenium^{73,74} and related reagents, for example, selenium dioxide^{75,76} and benzeneselenic anhydride⁷⁷ have long been used in dehydrogenation and aromatisation reactions in steroid chemistry. Although no aromatization reactions involving similar compounds to those in this study could be found in the chemical literature, it was nevertheless decided to attempt a selenium dioxide reaction on a benzoxazepinone. The reaction procedure of Bernstein and Littell⁷⁶ was followed in which the imide (89) and selenium dioxide were boiled under reflux in *tert*-butanol for 24 hours. Work-up and t.l.c. did not reveal any of the desired product, the major component being the hydrolysed imide [(18), R = Ph].

From these observations, it would appear that more work needs to be done in finding a suitable means of introducing the double bond Δ^2 -unsaturation. A

major problem appears to be the lack of a functional group at either the 2- or the 3-position, and the difficulty in introducing a suitable function once the ring system has been developed. This is largely due to the susceptibility of the heterocyclic ring to attack by acids and bases. A way of circumventing this problem could be to introduce suitable functionality at the flavanone or even the chalcone stage of the synthetic sequence.

2.2. Mass-spectrometric studies of the benzoxazepinones and tetrazoles

Low resolution mass spectra of the benzoxazepinones and the tetrazoles were obtained from solid probe experiments as a further means of confirming the identities of these compounds, some of which are novel. Some of the more intense peaks were found to be common to all the spectra, irrespective of the substituents, while other peaks were found to be common to all the spectra when the differences in atomic masses of the substituents were taken into account (Tables 4 and 5).

In order to analyse the fragmentation patterns of these compounds, the accurate masses of key peaks in the mass spectra of the parent systems {[(18), R = Ph] and (21)} were obtained by high resolution mass spectrometry. A summary of these results is contained in Tables 6 and 7, together with the most probable fragments, ††† their relative intensities, and calculated accurate masses.

The convention for quoting accurate masses is as follows:—

1. The observed and calculated accurate masses are quoted to four decimal places;
2. The observed and calculated masses are expected to correspond to within ± 0.005 mass units for peaks whose intensities are greater than 5% of the base peak, and to within ± 0.010 mass units for peaks whose intensities are less than 5% of the base peak;
3. Peaks whose intensities are less than 2% of the base peak are generally considered not worth measuring.

††† The most probable fragment was deemed to be that combination of C, H, N, and O atoms whose calculated accurate mass showed the closest correspondence with the observed accurate mass.

Cpd.	R ¹	R ²	Nominal mass peaks (<i>m/z</i>)						
18	H	H	119	121	148	152	181	210	239
74	Br	H	119	199	226	230	259	288	317
76	Cl	H	119	155	182	186	215	244	273
78	F	H	119	139	166	170	199	228	257
80	H	Br	197	121	148	152	259	288	317
82	H	Cl	153	121	148	152	215	244	273

Table 4

Nominal masses (*m/z*) of the most intense peaks in the mass spectra of 2,3-dihydro-2-phenyl-1,4-benzoxazepin-5(4H)-one [(18), R = Ph] and analogues.

Cpd.	R ¹	R ²	Nominal mass peaks (<i>m/z</i>)												
			103	104	105	117	134	152	180	208	209	219	220	235	264
21	H	H	103	104	105	117	134	152	180	208	209	219	220	235	264
75	Br	H	103	104	105	117	212	–	258	286	287	297	298	313	342
77	Cl	H	103	104	105	117	168	186	214	242	243	253	254	269	298
79	F	H	103	104	105	117	152	170	198	226	227	237	238	253	282
81	H	Br	181	182	183	117	134	152	258	286	287	297	298	313	342
83	H	Cl	137	138	139	117	134	152	214	242	243	253	254	269	298

Table 5

Nominal masses (*m/z*) of the most intense peaks in the mass spectra of 2,3-dihydro-2-phenyl-tetrazolo[1,5-d]-1,4-benzoxazepine (21) and analogues.

Measured Mass (m/z)	Fragment	Calculated Mass (m/z)	Relative Intensity (%)	Error
119.0633	C_8H_9N	119.0735	100.0	+0.0102
121.0190	$C_6H_3NO_2$	121.0164	47.1	-0.0026
148.0401	$C_8H_6NO_2$	148.0399	8.0	-0.0002
152.0634	$C_8H_{10}NO_2$	152.0712	5.2	+0.0078
181.0654	$C_{13}H_9O$	181.0653	16.3	-0.0001
210.0687	$C_{14}H_{10}O_2$	210.0681	4.6	-0.0001

Table 6

Accurate masses (m/z) of the peaks listed in table 4 for compound (18).

Measured Mass	Fragment	Calculated Mass	Relative Intensity (%)	Error
103.0547	C ₈ H ₇	103.0548	43.3	+0.0001
104.0625	C ₈ H ₈	104.0626	38.5	+0.0001
105.0648	C ₈ H ₉	105.0704	11.4	+0.0056
117.0581	C ₈ H ₇ N	117.0578	22.5	-0.0003
134.0479	C ₇ H ₆ N ₂ O	134.0480	38.4	+0.0001
152.0619	C ₁₂ H ₈	152.0626	4.1	+0.0007
180.0817	C ₁₃ H ₁₀ N	180.0813	4.4	-0.0004
208.0768	C ₁₄ H ₁₀ NO	208.0762	4.9	-0.0006
209.0843	C ₁₄ H ₁₁ NO	209.0841	11.8	-0.0002
219.0927	C ₁₅ H ₁₁ N ₂	219.0922	12.1	-0.0005
220.0961	C ₁₅ H ₁₂ N ₂	220.1000	5.1	+0.0039
235.0870	C ₁₅ H ₁₁ N ₂ O	235.0871	3.3	+0.0001

Table 7

Accurate masses (m/z) of the peaks listed in table 5 for compound (21).

The fragmentation pathways detailed in the following schemes (Schemes 23, 24 and 25) provide a tentative rationalisation of the mass spectrometric data

The benzoxazepinones' main fragmentation pattern is proposed to involve loss of a ketene species to give the odd electron ion responsible for the base peak, $C_8H_9N^{1+}$ (m/z 119, 100%) (Path 1a, Scheme 23); The ketene species may be lost either by direct rearrangement of the benzoxazepinone, or *via* the ring opened system, the latter process being analogous to that which occurs in the in the fragmentation of flavanones.⁷⁸ In path 1b, an enamine radical is lost, resulting in the cationic fragment, $C_7H_5O_2^+$ (m/z 121). The cation, $C_8H_8NO_2^+$ (m/z 148), which is formed *via* path 2, arises from loss of the radical $C_7H_7\cdot$. Loss of $CH_2=NH$ (path 3), affords the cation radical, $C_{14}H_{10}O_2^{1+}$ (m/z 210) for which the proposed structure is shown, and this can then lose carbon monoxide and a hydrogen radical to afford the benzyne cation, $C_{13}H_9O^+$ (m/z 181). The peak at m/z 152 could give rise to several possible structures with the formula C_8H_8 . However, a more detailed analysis of this particular fragment is necessary before any definite structure can be assigned.

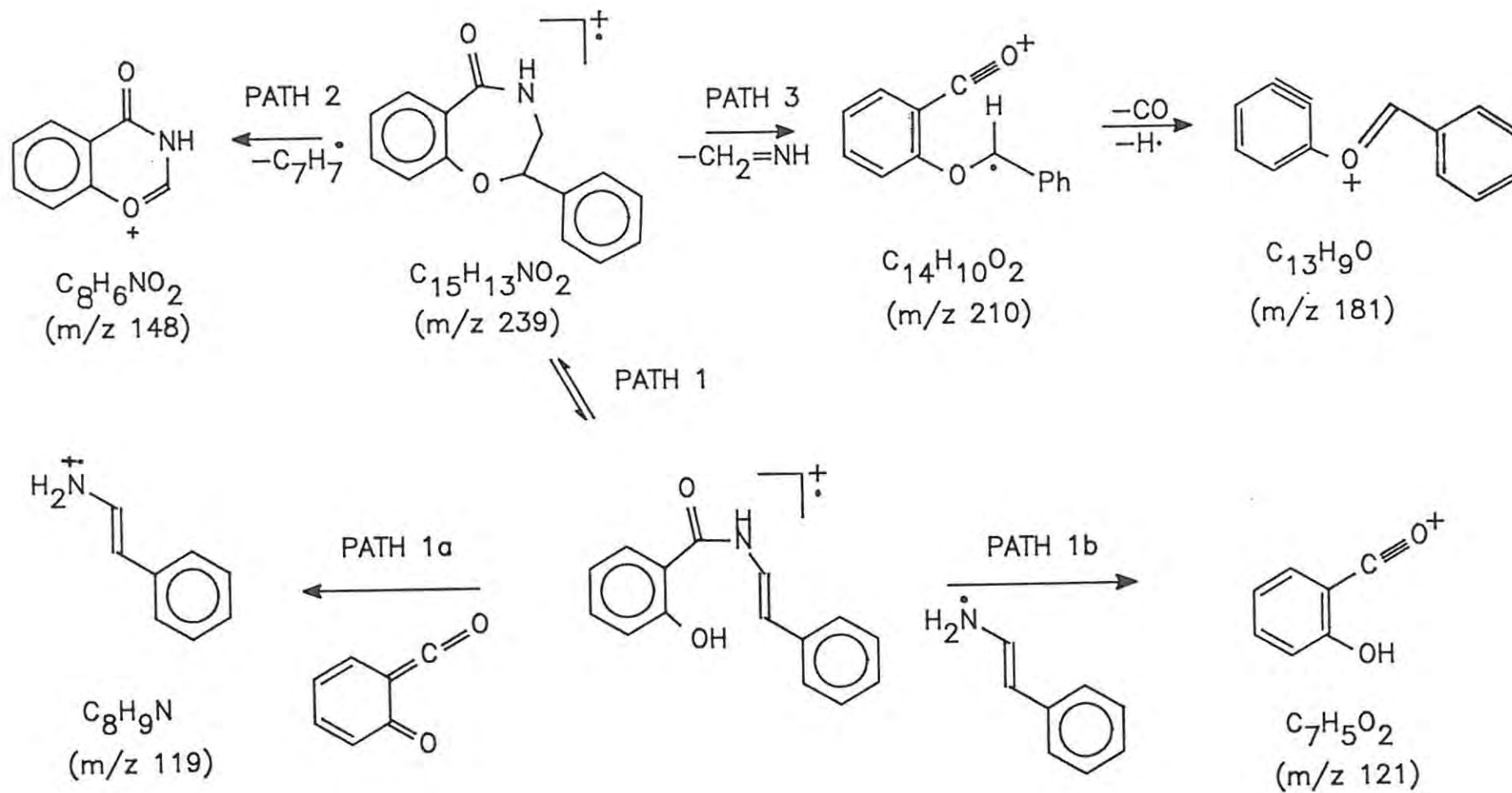

SCHEME 23

The proposed fragmentation patterns of the tetrazoles are more complex than those of the benzoxazepinones and are outlined in Schemes 24 and 25. The tetrazoles fragment according to certain well defined patterns.⁷⁹ One pattern, involving the initial loss of $N_2H\cdot$, followed by loss of HCN (path 1) affords cations $C_{15}H_{11}N_2O^+$ (m/z 235) and $C_{14}H_{10}NO^+$ (m/z 208). Rearrangement of the latter fragment (m/z 208) and loss of carbon monoxide gives the cation, $C_{13}H_{10}N^+$ (m/z 180). In path 2, loss of N_2 and HCN affords the cation radical, $C_{14}H_{11}NO^{\cdot+}$ (m/z 209). In path 3, loss of N_2O gives the odd electron species, $C_{15}H_{12}N_2^{\cdot+}$ (m/z 220) which loses a hydrogen radical to form the cationic fragment, $C_{15}H_{11}N_2^+$ (m/z 219). In path 4, ring opening similar to that observed in the flavanones is proposed, followed by rearrangement (path 4a) to give the linear species (91), fission of which affords the cation radical, $C_8H_7N^{\cdot+}$ (m/z 117). Path 4b involves loss of $C_7H_4N_4O$ to afford $C_8H_8^{\cdot+}$ (m/z 104) which can then lose a hydrogen radical to give $C_8H_7^{\cdot+}$ (m/z 103). The loss of $C_8H_8N_2$ (path 4c) gives the odd electron species, $C_7H_8N_2O^{\cdot+}$ (m/z 134) for which the proposed structure is shown.

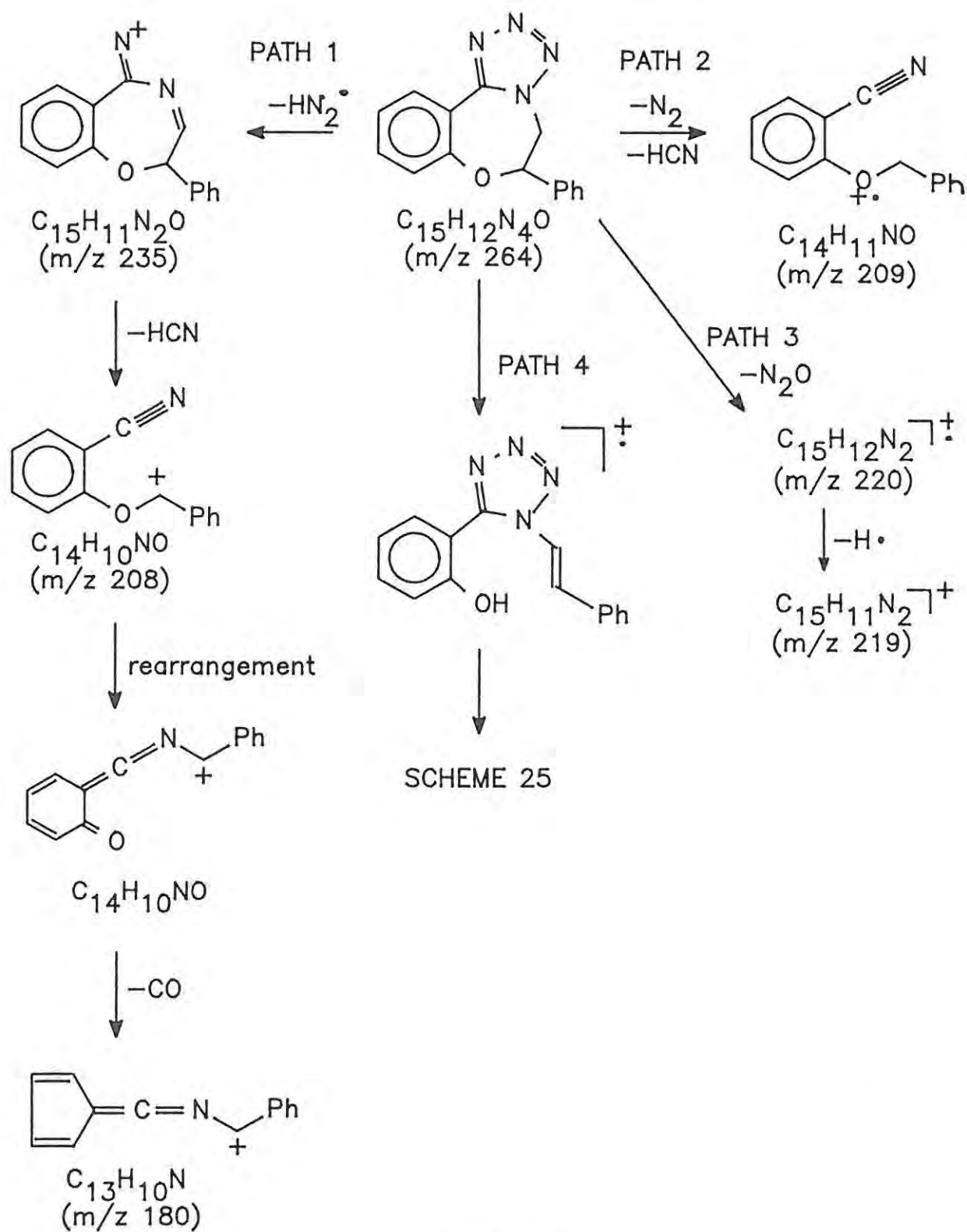

SCHEME 24

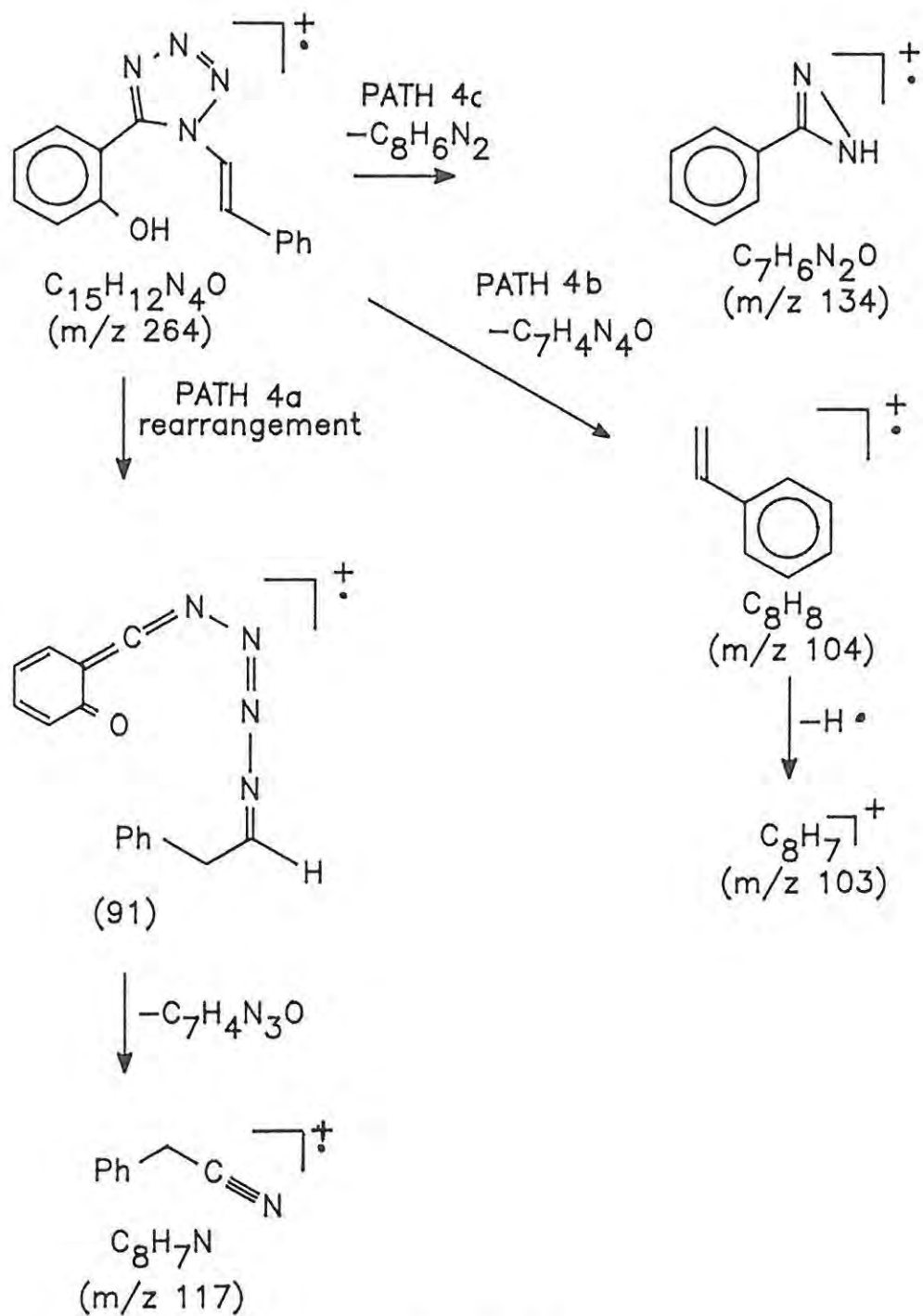

SCHEME 25

2.3. Conformational analysis of the benzoxazepinones and tetrazoles

As the mechanisms of drug-receptor interaction of the benzodiazepines have become more apparent at a molecular level (*cf.* Section 1.2.2), so the significance of the conformation of the drug molecule has become increasingly appreciated. Therefore, conformational analysis of the benzoxazepinones, as analogues of the benzodiazepines, is considered important. Several methods for determining the conformations of molecules are available to modern day chemists, including x-ray crystallography, ^1H n.m.r. spectroscopy, and molecular mechanics. Some work has already been done to determine the conformation of the heterocyclic ring of 1,4-benzoxazepin-5(4H)-ones, using ^1H n.m.r. techniques and these results will be reviewed and compared with those obtained in this study.⁷²

2.3.1. ^1H n.m.r. techniques

^1H n.m.r. spectroscopy may be used as an indirect method for determining the conformation of the heterocyclic ring of the systems studied here. The 2-H and 3-H nuclei in the flavanones and benzoxazepinones give rise to splitting patterns from which the coupling constants may be calculated. With the aid of the Karplus equations, it may then be possible to calculate the dihedral angles between these protons on the basis of the vicinal coupling constants. Once these angles have been obtained, recourse to molecular modelling can then show the conformation of the heterocyclic ring.

The Karplus equations may be written as follows:—⁸⁰

$${}^3J_{ab} = J^0 \cos^2 \phi - 0.38 \quad (0^\circ \leq \phi \leq 90^\circ) \quad \text{— equation 1}$$

$${}^3J_{ab} = J^{180} \cos^2 \phi - 0.38 \quad (90^\circ \leq \phi \leq 180^\circ) \quad \text{— equation 2}$$

where ${}^3J_{ab}$ is the vicinal coupling constant, J^0 and J^{180} are constants which depend on the substituents on the carbon atoms and ϕ is the dihedral angle.

The problem with using these equations arises in the choice of J^0 and J^{180} values, because some of the factors which affect these are themselves dependent on ϕ .^{81,82} Often, however, the problem is not to determine the precise dihedral angle, but merely to distinguish between two conformational possibilities, *e.g.* whether there are two *gauche* vicinal couplings (*i.e.* relatively small J values), or one *gauche* and one *anti* (or *eclipsed*) coupling (*i.e.* one large and one small J value). Williams and Fleming⁸⁰ suggest using $J^0 = 8.5$ and $J^{180} = 9.5$ when no other values are readily available.

Duddeck and Levai⁷² used models to estimate the conformations of the heterocyclic ring in a series of benzoxazepinone analogues and proposed the 'quasi-equatorial' (92) and 'quasi-axial' (93) forms as conformational options (Scheme 26). These authors believe that the quasi-axial form is the least

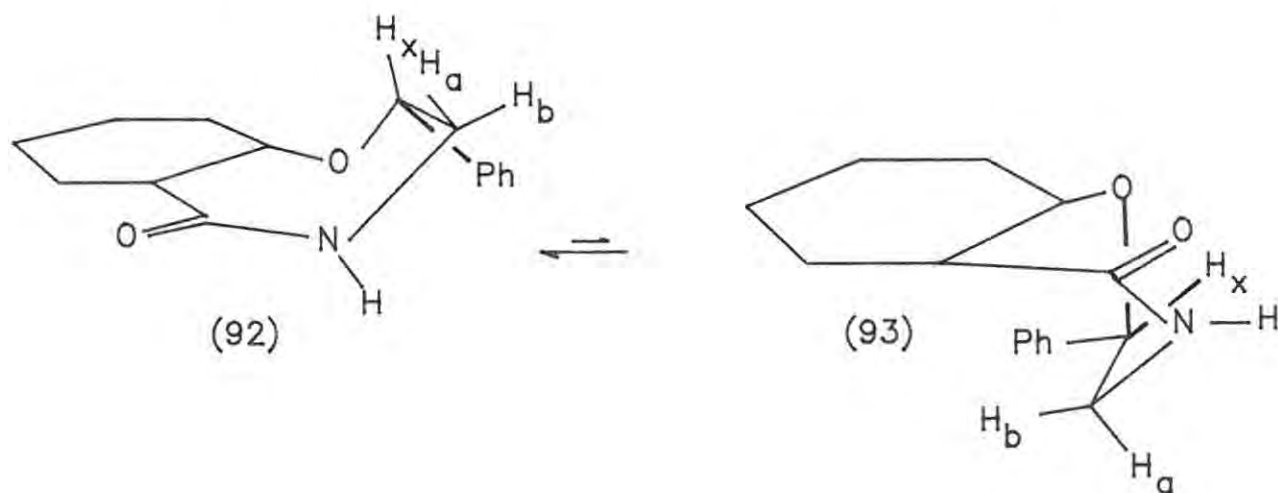

stable due to steric repulsion between 9-H and the *o*-hydrogen of the 2-phenyl group, which is orientated perpendicularly to the plane of the fused benzene ring. Therefore, the quasi-equatorial form (92) should be the preferred conformation. The coupling constants which they observed (*viz.*, $J_{ax} = 3.6\text{Hz}$ and $J_{bx} = 0.6\text{Hz}$) seem to support their theory and dihedral angles of *ca.* $55\text{--}65^\circ$ and $70\text{--}80^\circ$, respectively, were expected. If the quasi-axial form is the preferred conformation, then a much larger coupling constant for J_{bx} , corresponding to a dihedral angle of 170° would be expected. However, in the present study of the benzoxazepinone [(18), R = Ph], J_{ax} and J_{bx} were observed to be 3.4 and 6.7Hz, respectively. By applying the Karplus equations to these values, and using the J^0 and J^{180} suggested by Williams and Fleming, the angles between protons H_x and H_a (*ca.* 40°) and H_x and H_b (*ca.* 150°) could be estimated. These values for the angles suggest that the heterocycle does not adopt either of the conformations proposed by Duddeck and Levai⁷² but rather some intermediate conformation in which the heterocyclic ring is more coplanar with the fused benzene.

Clearly, then, another method of determining the conformation of the heterocyclic ring is necessary. Computerised molecular modelling, in conjunction with molecular mechanics software were used to provide a possible solution to this problem (*cf.* Section 2.3.2)

In the case of the unsubstituted tetrazole analogues, a somewhat different picture was obtained. In the ^1H n.m.r. spectrum of 2,3-dihydro-2-phenyl-tetrazolo[1,5-d]-1,4-benzoxazepine (21), the splitting patterns were not fully resolved, with the geminal coupling constant of 14.7Hz and one vicinal coupling constant of 9.7Hz being the only determinable figures. This suggested that the other vicinal coupling constant was very small. With 8-bromo-2,3-

dihydro-2-phenyl-tetrazolo[1,5-d]-1,4-benzoxazepine (75), however, the splitting patterns were resolved and vicinal coupling constants of 9.7 and 1.3Hz were observed. From these couplings, it would appear that there is one *gauche*- and one *anti*-coupling, which is consistent with the half chair conformation shown below (Figure 7).

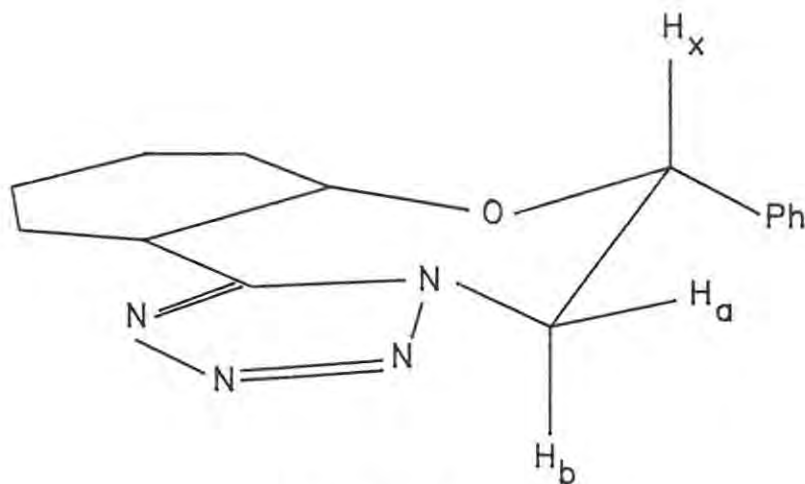

FIGURE 7

If H_x and H_b are, in fact, *anti*-periplanar, then it may be safe to assume that $J_{xb} = J^0 = J^{180} = 9.7\text{Hz}$. Using this assumption and Karplus equation 1, then the dihedral angle between H_x and H_a can be estimated to be *ca.* 60° . In an attempt to prove this theory, molecular modelling and molecular mechanics were used to find the most stable conformation of the tetrazoles (*cf.* Section 2.3.2).

2.3.2. Molecular modelling

The molecular modelling software which was used in this project, *viz.* Alchemy, provides a means of computer modelling a specimen system, which may then be altered using the iterative *minimize* command to afford a conformation corresponding to a local energy minimum. In the *Alchemy* package, the total

conformational energy of a particular structure is given by equation 3.

$$E = E_{\text{str}} + E_{\text{ang}} + E_{\text{tor}} + E_{\text{vdw}} + E_{\text{oop}} \quad \text{--- equation 3}$$

where E is the total conformational energy of the specimen system, E_{str} is the bond stretching energy, E_{ang} is the angle bending energy, E_{tor} is the torsional deformation energy, E_{vdw} is the Van Der Waals interactions energy (a steric term), and E_{oop} is the out of plane bending energy.⁸³

When minimizing structures using *Alchemy* caution should be used in the final analysis, because the minimize option does not necessarily find the global minimum energy conformation of a particular molecule. If a molecule is constructed in a particular conformation, the *Alchemy* minimizer will tend towards a conformation which may only correspond to a local energy minimum. Therefore, the initial conformation must be chosen carefully.

By placing the benzoxazepinone in conformations similar to those proposed by Duddeck and Levai,⁷² and then performing an energy minimization operation, it was possible to establish which conformation was the most stable, *i.e.* the lowest energy conformation. In fact, it was found that the equilibrium tended to favour the, so called, quasi-axial conformation (95) which had a minimum energy of 2.8kcal.mol⁻¹. The quasi-equatorial conformation (94) was found to have a minimum energy of 4.3kcal.mol⁻¹ (Scheme 26). These results tend to oppose the findings of Duddeck and Levai.⁷²

The ¹H n.m.r. spectrum for the minimised quasi-axial (95) form would also be expected to reflect a large J_{bx} value, corresponding to a dihedral angle of approximately 160°, and a small J_{ax} value, corresponding to an angle of

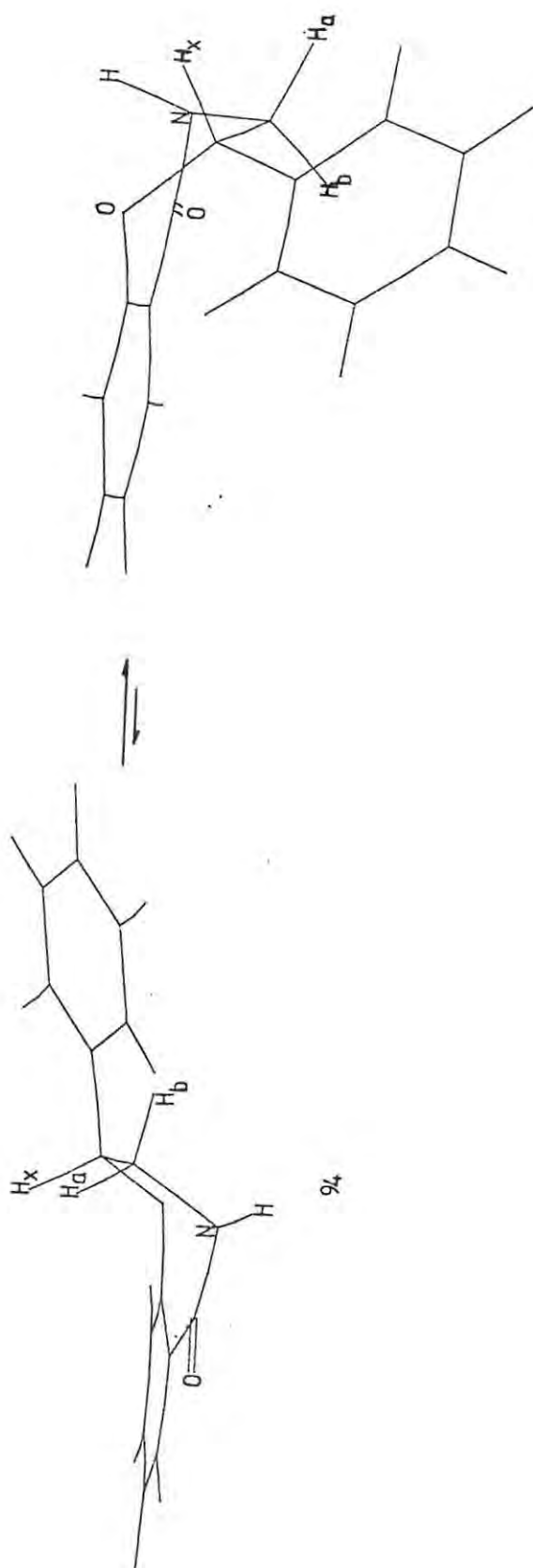

SCHEME 26

95

94

approximately 40° . In the quasi-equatorial conformation (94), J_{ax} should be large, corresponding to a small dihedral angle (*ca.* 7°) and J_{bx} should be relatively small, corresponding to a *gauche* interaction (*ca.* 126°). Neither of these conformations appeared to correspond to the n.m.r. data obtained in the present study, and it was decided to attempt a minimization on some conformation which was approximately the average of the two extremes (96).

A benzoxazepinone structure, in which the heterocycle is approximately coplanar with the fused benzene ring was constructed. The conformation obtained by an energy minimization process proved to have the lowest conformational energy of the three benzoxazepinone structures thus far discussed (*viz.* -2.0kcal.mol^{-1}). As can be seen in Figure 8, the heterocyclic ring appears to have adopted a conformation not unlike the quasi-equatorial arrangement of Duddeck and Levai, although, not as extreme. The dihedral angles between H_x and H_a and H_x and H_b were measured and found to be 40° and 159° , respectively. Therefore, J_{ax} should be small for the *gauche* interaction and J_{bx} should be large for the *anti* interaction, which is exactly what is observed in the proton n.m.r. spectrum of this compound. (*cf.* Section 2.3.1).

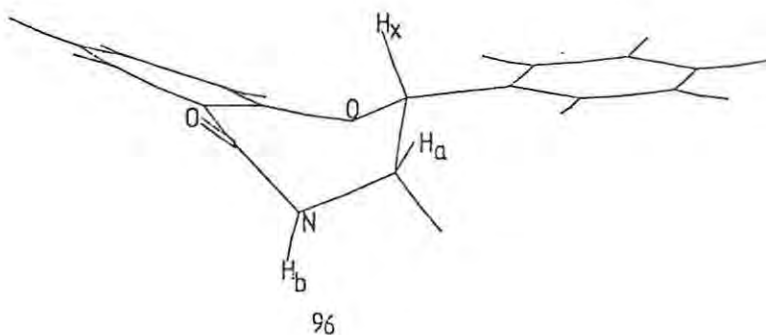
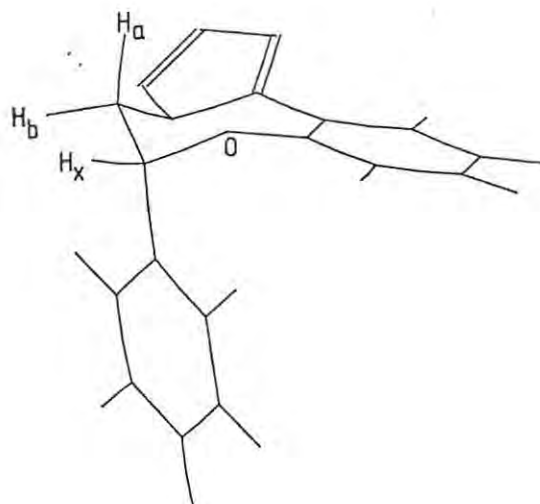

FIGURE 8

Thus, it is postulated that the quasi-axial and equatorial forms proposed by Duddeck and Levai ⁷² are extreme conformations. Both the ¹H n.m.r. data and the molecular mechanics determinations seem to indicate that the heterocyclic ring prefers to adopt a conformation which is a more planar version of the quasi-equatorial form (96).

With the tetrazoles, a similar result was anticipated, and minimizations were carried out on starting conformations which approximated to those used for the benzoxazepinones. However, all three minimizations produced structures of similar energy, and the dihedral angles obtained from these minimum conformations suggested the presence of *gauche* interactions only, implying that the couplings in these compounds should all be small (Figure 9). This is inconsistent with the n.m.r. data which was actually obtained for these compounds and so no conclusion can be drawn from the molecular mechanics investigation of the tetrazole system



Conformational energy = 8.7 kcal/mol

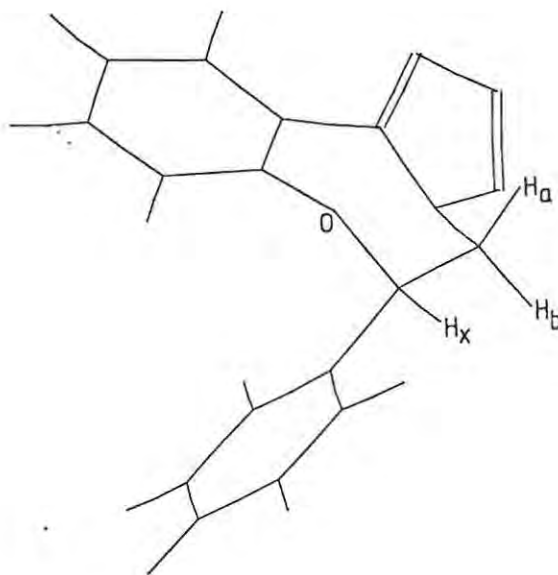

Conformational energy = 8.9 kcal/mol

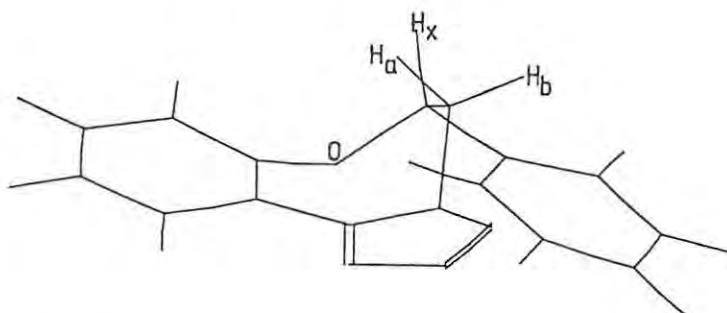

Conformational energy = 10.8 kcal/mol

FIGURE 9

3. EXPERIMENTAL

All melting points were determined on a Mettler FP1 melting point apparatus and are uncorrected. 60MHz ^1H n.m.r. spectra were recorded on a Perkin Elmer R12a n.m.r. instrument. High field ^1H and ^{13}C n.m.r. spectra were recorded on Bruker AM300 or Bruker WM500 instruments with tetramethylsilane as internal standard. Low resolution mass spectra were recorded by solid probe determinations on a Hewlett Packard 5988A mass spectrometer and high resolution mass spectrometry was performed on a Varian Mat 212 mass spectrometer.

Molecular modelling and molecular mechanics were performed on a CW16 AT computer with EGA card using *Tripos Associates' Alchemy II*.

T.l.c. analysis was performed on *MERCK* Silica gel 60F₂₅₄ precoated plastic plates and flash chromatography was carried out on *MERCK* Silica gel 60 [particle size 0.040–0.063mm (230–400 mesh ASTM)].

3-Chlorophenyl acetate (51).⁵⁵ Ac₂O (6.0mL, 62mmol) was added dropwise over 25 min. to a stirred solution of 3-chlorophenol (5.0g, 39mmol) and NaOH (2.5g, 62mmol) in H₂O (ca. 100mL) maintained at ca. 0° C in an ice-salt bath. The resulting two-phase mixture was stirred for 1h. at 0° C and then extracted with Et₂O (2×30mL). The combined ethereal extracts were washed with 10% aq. NaHCO₃ (3×30mL) and saturated aq. NaCl, and then dried (anhyd. MgSO₄). The solvent was evaporated *in vacuo* to give the crude ester as a brown oil (5.7g, 86%), which was distilled to afford 3-chlorophenyl acetate (51) as a pale yellow oil, b.p. 55° C / 0.7mmHg (Lit.⁵⁵ 105–107° C / 13mmHg); δ_{H} (60MHz, CDCl₃) 2.3 (3H, s, COMe) and 6.9–7.7 (4H, m, ArH).

3-Bromophenyl acetate (52).⁵⁵ The experimental procedure employed for the synthesis of 3-chlorophenyl acetate (51) was followed, using Ac₂O (4.3mL, 46mmol), 3-bromophenol (5.0g, 29mmol), and NaOH (1.8g, 46mmol) in H₂O (ca. 50mL). Work-up afforded an oil which was distilled to give 3-bromophenyl acetate (52) (4.0g, 64%), b.p. 69.7° C / 0.25mmHg (Lit.¹⁰⁵ 149° C / 40mmHg); δ_{H} (60MHz, CDCl₃) 2.2 (3H, s, COMe), and 6.8–7.5 (4H, m, ArH).

3-Fluorophenyl acetate (53).⁵⁵ The experimental procedure employed for the synthesis of 3-chlorophenyl acetate (51) was followed, using Ac₂O (16.5mL, 174mmol), 3-fluorophenol (12.4g, 110mmol), and NaOH (6.8g, 174mmol) in H₂O (ca. 50mL). Work-up afforded an oil which was distilled to give 3-fluorophenyl acetate (53) (16.4g, 96%) b.p. 46–47° C / 1.5mmHg; δ_{H} (60MHz, CDCl₃) 2.2 (3H, s, COMe) and 6.4–7.6 (5H, m, ArH).

4'-Chloro-2'-hydroxyacetophenone (54).⁵⁶ A mixture of 3-chlorophenyl acetate (51) (2.1g, 11.7mmol) and AlCl₃ (3.8g, 28.0mmol) was heated on an oil

bath at 175–180°C for 1.5h. The cooled mixture was treated with dil. HCl (ca. 50mL) and then steam distilled. The distillate was extracted with CHCl₃ (3×20mL) and the combined organic extracts were re-extracted with aq. 0.5M KOH. The combined alkaline solutions were then washed with CHCl₃ (2×20mL), acidified with dil. HCl, and extracted with further portions of CHCl₃ (2×20mL). The CHCl₃ extracts were combined, dried (anhyd. MgSO₄) and evaporated to afford crude 4'-chloro-2'-hydroxyacetophenone (54) (1.8g, 84%), b.p. 74°C / 0.25mmHg (Lit. ⁵⁶ 121–124°C / 15mmHg); δ_{H} (60MHz, CDCl₃) 2.6 (3H, s, COMe), 6.7–6.9 (2H, m, 3-H and 5-H), 7.6 (1H, d, *J* 8Hz, 6-H), and 12.4 (1H, s, OH).

4'-Bromo-2'-hydroxyacetophenone (55). ⁵⁶ The experimental procedure employed for the synthesis of 4'-chloro-2'-hydroxyacetophenone (54) was followed, using 3-bromophenyl acetate (52) (6.0g, 28mmol) and AlCl₃ (12.3g, 93mmol). In this case the reaction mixture was heated for 3h. Work-up afforded 4'-bromo-2'-hydroxyacetophenone (55) (2.2g, 37%), m.p. 41–42°C (Lit. ⁵⁶ m.p. 42–43°C); δ_{H} (60MHz, CDCl₃) 2.6 (3H, s, COMe), 6.9–7.2 (2H, m, 3-H and 5-H), 7.6 (1H, d, *J* 8Hz, 6-H), and 12.4 (1H, s, OH).

4'-Fluoro-2'-hydroxyacetophenone (56). ⁵⁶ The experimental procedure employed for the synthesis of 4'-chloro-2'-hydroxyacetophenone (54) was followed, using 3-fluorophenyl acetate (53) (11.0g, 71mmol) and AlCl₃ (20.6g, 155mmol). Work-up afforded 4'-fluoro-2'-hydroxyacetophenone (56) (9.92g, 92%), b.p. 98°C / 0.3mmHg (Lit. ⁸⁵ m.p. 24°C); δ_{H} (60MHz, CDCl₃) 2.6 (3H, s, COMe), 6.5–8.1 (3H, m, ArH), and 12.7 (1H, s, OH).

1-(2-Hydroxyphenyl)-3-phenyl-2-propen-1-one (15). ⁵⁶ A cooled solution of KOH (8.8g, 230mmol) in H₂O (ca. 50mL) was added to a cold solution of

2'-hydroxyacetophenone (13) (10.0g, 73mmol) and benzaldehyde (15.5g, 146mmol) in EtOH (100mL). The reaction mixture was kept at 0° C for 4d. and then H₂O (ca. 100mL) was added and the resulting mixture acidified with dil. HCl. causing the colour of the solution to change from deep red to milky-yellow. The bright yellow crystals which formed slowly were filtered off and recrystallised from hot EtOH to afford 1-(2-hydroxyphenyl)-3-phenyl-2-propen-1-one (15) (13.2g, 73%), m.p. 88° C (Lit. ⁵⁸ 89° C); δ_{H} (60MHz, CDCl₃) 6.7-8.2 (9H, m, ArH and CH=CH) and 12.9 (1H, br, OH).

1-(4-Chloro-2-hydroxyphenyl)-3-phenyl-2-propen-1-one (57). ⁵⁶ The experimental procedure employed for the synthesis of 1-(2-hydroxyphenyl)-3-phenyl-2-propen-1-one (15) was followed, using KOH (9.9g, 176mmol) in H₂O (ca. 50mL), 4'-chloro-2'-hydroxyacetophenone (54) (10.0g, 59mmol) and benzaldehyde (12.4g, 117mmol) in EtOH (200mL). Work-up and recrystallisation from hot EtOH afforded 1-(4-Chloro-2-hydroxyphenyl)-3-phenyl-2-propen-1-one (57) (14.3g, 93%), m.p. 126° C (Lit. ⁵⁶ 124-125° C); δ_{H} (60MHz, CDCl₃) 6.5-8.0 (10H, m, ArH and CH=CH) and 12.7 (1H, s, OH).

1-(4-Bromo-2-hydroxyphenyl)-3-phenyl-2-propen-1-one (58). ⁵⁶ The experimental procedure employed for the synthesis of 1-(2-hydroxyphenyl)-3-phenyl-2-propen-1-one (15) was followed, using KOH (7.9g, 140mmol) in H₂O (ca. 50mL) and 4'-bromo-2'-hydroxyacetophenone (55) (10.0g, 47mmol) and benzaldehyde (9.9g, 93mmol) in EtOH (200mL). Work-up and recrystallisation from hot EtOH afforded 1-(4-bromo-2-hydroxyphenyl)-3-phenyl-2-propen-1-one (54) (10.2g, 72%), m.p. 115° C (Lit. ⁵⁶ 115-116° C); δ_{H} (60MHz, CDCl₃) 7.0-8.0 (10H, m, ArH and CH=CH) and 12.9 (1H, s, OH).

1-(4-Fluoro-2-hydroxyphenyl)-3-phenyl-2-propen-1-one (59). ⁵⁶ The

experimental procedure employed for the synthesis of 1-(2-hydroxyphenyl)-3-phenyl-2-propen-1-one (15) was followed using KOH (9.8g, 175mmol) in H₂O (*ca.* 50mL) and 4'-fluoro-2'-hydroxyacetophenone (56) (9.0g, 58mmol) and benzaldehyde (12.4g, 117mmol) in EtOH (200mL). Work-up and recrystallisation from hot EtOH afforded pure 1-(4-fluoro-2-hydroxyphenyl)-3-phenyl-2-propen-1-one (59) (10.7g, 76%), m.p. 111°C (Lit. ⁸⁵ 110–111°C); δ_{H} (60MHz, CDCl₃) 6.6–7.9 (10H, m, ArH and CH=CH) and 13.2 (1H, s, OH).

3-(4-Chlorophenyl)-1-(2-hydroxyphenyl)-2-propen-1-one (60). ⁵⁶ The experimental procedure employed for the synthesis of 1-(2-hydroxyphenyl)-3-phenyl-2-propen-1-one (15) was followed using KOH (12.5g, 222mmol) in H₂O (*ca.* 100mL) and 2'-hydroxyacetophenone (13) (10.0g, 74mmol) and 4-chlorobenzaldehyde (20.8g, 148mmol) in EtOH (200mL). Work-up and recrystallisation from hot EtOH afforded pure 3-(4-chlorophenyl)-1-(2-hydroxyphenyl)-2-propen-1-one (60). (17.0g, 89%), m.p. 144°C (Lit. ⁸⁶ 150°C); δ_{H} (60MHz, CDCl₃) 6.9–8.0 (10H, m, ArH and CH=CH) and 12.7 (1H, s, OH).

3-(4-Bromophenyl)-1-(2-hydroxyphenyl)-2-propen-1-one (61). ⁵⁶ The experimental procedure employed for the synthesis of 1-(2-hydroxyphenyl)-3-phenyl-2-propen-1-one (15) was followed using KOH (4.5g, 81mmol) in H₂O (*ca.* 20mL) and 2'-hydroxyacetophenone (13) (3.7g, 27mmol) and 4-bromobenzaldehyde (5.0g, 27mmol) in EtOH (100mL). Work-up and recrystallisation from hot EtOH afforded pure 3-(4-bromophenyl)-1-(2-hydroxyphenyl)-2-propen-1-one (61). (3.2g, 39%), m.p. 148°C (Lit. ⁸⁷ 150°C); δ_{H} (60MHz, CDCl₃) 6.9–7.9 (10H, m, ArH and CH=CH) and 12.7 (1H, s, OH).

3-(4-Fluorophenyl)-1-(2-hydroxyphenyl)-2-propen-1-one (62).⁵⁶ The experimental procedure employed for the synthesis of 1-(2-hydroxyphenyl)-3-phenyl-2-propen-1-one (15) was followed using KOH (6.2g, 110mmol) in H₂O (ca. 100mL) and 2'-hydroxyacetophenone (13) (10.0g, 74mmol) and 4-fluorobenzaldehyde (20.8g, 148mmol) in EtOH (200mL). Work-up and recrystallisation from hot EtOH afforded pure 3-(4-fluorophenyl)-1-(2-hydroxyphenyl)-2-propen-1-one (62). (17.0g, 89%), m.p. 144°C (Lit.¹³ 118–119°C); δ_{H} (60MHz, CDCl₃) 6.9–7.9 (10H, m, ArH and CH=CH) and 12.8 (1H, s, OH).

2,3-Dihydro-2-phenyl-4H-1-benzopyran-4-one (1).⁵⁶ H₃PO₄ (d. 1.69, 150mL) was added to a solution of 1-(2-hydroxyphenyl)-3-phenyl-2-propen-1-one (15) (25g, 111mmol) in EtOH (400mL) and the resulting solution was boiled under reflux for 4d. The reaction mixture was concentrated *in vacuo* and allowed to stand for several days while the product precipitated out of solution. Recrystallisation of the crude product from hot EtOH afforded 2,3-dihydro-2-phenyl-4H-1-benzopyran-4-one (1) (11.5g, 46%), m.p. 77°C (Lit.⁸⁸ 77–78°C); δ_{H} (500MHz, CDCl₃) 2.9 (1H, dd, *J* 2.9 and 16.8Hz, 3-H), 3.0 (1H, dd, *J* 13.3 and 16.9Hz, 3-H), 5.5 (1H, dd, *J* 2.9 and 13.3Hz, 2-H), and 7.0–7.9 (9H, m, ArH); δ_{C} (CDCl₃) 44.48 † (t, †† C-3), 79.41 (d, C-2), 117.96 (d, C-8), 120.81 (s, C-4a), 121.44 (d, C-6), 126.00 (d, C-2' and C-6'), 126.88 (d, C-5), 128.56 (d, C-4'), 128.67 (d, C-3' and C-5'), 135.97 (d, C-7), 138.63 (s, C-1'), 161.37 (s, C-8a), and 191.62 (s, C-4).

†The ¹³C δ -values which are quoted were taken from the proton noise decoupled spectra for the respective compounds.

††The multiplicity of the ¹³C peaks was obtained from the proton-coupled spectra for the respective compounds.

7-Bromo-2,3-dihydro-2-phenyl-4H-1-benzopyran-4-one (63). ⁵⁶ H₃PO₄ (d. 1.69, 50mL) was added to a solution of 1-(4-bromo-2-hydroxyphenyl)-3-phenyl-2-propen-1-one (58) (10.0g, 33mmol) in EtOH (250mL) and the resulting solution was boiled under reflux for 4d. The reaction mixture was then poured into water and extracted with EtOAc, dried (anhyd. MgSO₄) and evaporated. The residue was chromatographed (flash chromatography; elution with toluene) to afford two fractions, *viz.*,

i) starting material (4.1g); and

ii) 7-bromo-2,3-dihydro-2-phenyl-4H-1-benzopyran-4-one (63) (5.9g, 59%), m.p. 78° C (from EtOH) (Lit. ⁵⁶ 79–80° C); δ_{H} (300MHz, CDCl₃) 2.9 (1H, dd, *J* 3.1 and 16.9Hz, 3-H), 3.1 (1H, dd, *J* 13.1 and 16.9Hz, 3-H), 5.5 (1H, dd, *J* 3.0 and 12.9Hz, 2-H), and 7.2–7.8 (8H, m, ArH); δ_{C} (CDCl₃) 44.30 (t, C-3), 79.92 (d, C-2), 119.82 (s, C-4a), 121.32 (d, C-8), 125.23 (d, C-5), 126.07 (d, C-2' and C-6'), 128.22 (d, C-6), 128.86 (d, C-3', C-4', and C-5'), 130.52 (s, C-7), 138.19 (s, C-1'), 161.64 (s, C-8a), and 190.89 (s, C-4).

7-Chloro-2,3-dihydro-2-phenyl-4H-1-benzopyran-4-one (64). ⁵⁶ The experimental procedure employed for the synthesis of 7-bromo-2,3-dihydro-2-phenyl-4H-1-benzopyran-4-one (63) was followed, using H₃PO₄ (d. 1.69, 50mL) and 1-(4-chloro-2-hydroxyphenyl)-3-phenyl-2-propen-1-one (57) (10.0g, 39mmol) in EtOH (250mL). Work-up and flash chromatography (elution with toluene) afforded two fractions, *viz.*,

i) starting material; and

ii) 7-chloro-2,3-dihydro-2-phenyl-4H-1-benzopyran-4-one (64) (4.4g, 44%), m.p. 53–55° C (from EtOH) (Lit. ⁵⁶ 54–55.5° C); δ_{H} (300MHz, CDCl₃) 2.9 (1H, dd, *J* 3.1 and 19.9Hz, 3-H), 3.1 (1H, dd, *J* 12.9 and 17.0Hz, 3-H), 5.5 (1H, dd, *J* 3.1 and 12.8Hz, 2-H), and 7.0–7.9 (8H, m, ArH); δ_{C} (CDCl₃) 44.24 (t, C-3), 79.91 (d, C-2), 118.22 (d, C-8), 119.46 (s, C-4a), 122.35 (d, C-5),

126.06 (d, C-2' and C-6'), 128.21 (d, C-6), 128.83 (d, C-3', C-4', and C-5'), 138.19 (s, C-1'), 141.94 (s, C-7), 161.76 (s, C-8a), and 190.96 (s, C-4).

7-Fluoro-2,3-dihydro-2-phenyl-4H-1-benzopyran-4-one (65).⁵⁶ The experimental procedure employed for the synthesis of 7-bromo-2,3-dihydro-2-phenyl-4H-1-benzopyran-4-one (63) was followed, using H_3PO_4 (d. 1.69, 45mL) and 1-(4-fluoro-2-hydroxyphenyl)-3-phenyl-2-propen-1-one (59) (10.0g, 41mmol) in EtOH (250mL). Work-up and flash chromatography (elution with toluene) afforded two fractions, *viz.*,

i) starting material(2.4g); and

ii) 7-fluoro-2,3-dihydro-2-phenyl-4H-1-benzopyran-4-one (65) (6.7g, 67%), b.p. $140^\circ\text{C}/0.35\text{mmHg}$; δ_{H} (300MHz, CDCl_3) 2.9 (1H, dd, J 2.9 and 16.9Hz, 3-H), 3.0 (1h, dd, J 12.9 and 16.8Hz, 3-H), 5.5 (1h, dd, J 2.8 and 12.9Hz, 2-H), and 6.7-8.0 (8H, m, ArH); δ_{C} (CDCl_3) 44.05 (t, C-3), 80.00 (d, C-2), 104.74 (dd \ddagger , $^2J_{\text{CF}}$ 24.5Hz, C-8), 109.86 (dd, $^2J_{\text{CF}}$ 22.9Hz, C-6), 117.79 (d, C-4a), 126.00 (d, C-2' and C-6'), 128.74 (d, C-3', C-4', and C-5'), 129.44 (dd, $^3J_{\text{CF}}$ 11.2Hz, C-5), 138.19 (s, C-1'), 163.00 (sd, $^3J_{\text{CF}}$ 13.5Hz, C-8a), 167.39 (dd, $^3J_{\text{CF}}$ C-7), and 190.18 (s, C-4).

2-(4-Bromophenyl)-2,3-dihydro-4H-1-benzopyran-4-one (66).⁵⁶ The experimental procedure employed for the synthesis of 7-bromo-2,3-dihydro-2-phenyl-4H-1-benzopyran-4-one (63) was followed, using H_3PO_4 (d. 1.69, 8mL) and 3-(4-bromophenyl)-1-(2-hydroxyphenyl)-2-propen-1-one (61) (2.0g, 6.6mmol) in EtOH (150mL). Work-up and flash chromatography (elution with toluene) afforded two fractions, *viz.*,

i) starting material; and

\ddagger When there is a proton attached to a carbon which is coupling to fluorine a double doublet (dd) is observed but when there are no protons attached to a carbon which is coupling to fluorine, a single doublet (sd) is observed.

ii) 2-(4-bromophenyl)-2,3-dihydro-4H-1-benzopyran-4-one (66) (1.6g, 80%), m.p. 117° C (from EtOH) (Lit. ⁸⁷ 117° C); δ_{H} (300MHz, CDCl₃) 2.9 (1H, dd, *J* 3.3 and 16.8Hz, 3-H), 3.0 (1H, dd, *J* 12.9 and 16.8Hz, 3-H), 5.4 (1H, dd, *J* 3.1 and 12.9Hz, 2-H), and 7.0–7.9 (8H, m, ArH); δ_{C} (CDCl₃) 44.48 (t, C-3), 78.78 (d, C-2), 118.03 (d, C-8), 120.87 (s, C-4a), 121.77 (d, C-6), 122.65 (s, C-4'), 127.04 (d, C-5), 127.75 (d, C-2' and C-6'), 131.95 (d, C-3' and C-5'), 136.22 (d, C-7), 137.77 (s, C-1'), 161.23 (s, C-8a), and 191.34 (s, C-4).

2-(4-Chlorophenyl)-2,3-dihydro-4H-1-benzopyran-4-one (67). ⁵⁶ The experimental procedure employed for the synthesis of 7-bromo-2,3-dihydro-2-phenyl-4H-1-benzopyran-4-one (63) was followed, using H₃PO₄ (d. 1.69, 13mL) and 3-(4-chlorophenyl)-1-(2-hydroxyphenyl)-2-propen-1-one (60) (3.0g, 12mmol) in EtOH (300mL). Work-up and flash chromatography [elution with hexane-EtOAc (5:1)] afforded two fractions, *viz.*,

i) starting material; and

ii) 2-(4-chlorophenyl)-2,3-dihydro-4H-1-benzopyran-4-one (67) (0.6g, 20%), m.p. 85° C (from EtOH) (Lit. ⁸⁶ 87° C); δ_{H} (500MHz, CDCl₃) 2.8 (1H, dd, *J* 2.9 and 16.8Hz, 3-H), 3.0 (1H, dd, *J* 13.1 and 16.8Hz, 3-H), 5.4 (1H, dd, *J* 2.9 and 13.1Hz, 2-H), and 7.0–7.9 (8H, m, ArH); δ_{C} (CDCl₃) 44.42 (t, C-3), 78.67 (d, C-2), 117.96 (d, C-8), 120.81 (s, C-4a), 121.68 (d, C-6), 126.96 (d, C-5), 127.42 (d, C-2' and C-6'), 128.91 (d, C-3' and C-5'), 134.42 (s, C-4'), 136.12 (d, C-7), 137.22 (s, C-1'), 161.17 (s, C-8a), and 191.25 (s, C-4).

2-(4-Fluorophenyl)-2,3-dihydro-4H-1-benzopyran-4-one (68). ⁵⁶ The experimental procedure employed for the synthesis of 7-bromo-2,3-dihydro-2-phenyl-4H-1-benzopyran-4-one (63) was followed, using H₃PO₄ (d. 1.69, 23mL) and 3-(4-fluorophenyl)-1-(2-hydroxyphenyl)-2-propen-1-one (62) (5.0g, 21mmol) in EtOH (300mL). Work-up and flash chromatography

(elution with benzene) afforded two fractions, *viz.*,

- i) starting material (0.6g); and
- ii) 2-(4-fluorophenyl)-2,3-dihydro-4H-1-benzopyran-4-one (68) (4.2g, 84%), m.p. 79° C (from EtOH); δ_{H} (500MHz, CDCl₃) 2.8 (1H, dd, *J* 2.9 and 16.8Hz, 3-H), 3.0 (1H, dd, *J* 13.3 and 16.8Hz, 3-H), 5.4 (1H, dd, *J* 2.9 and 13.3Hz, 2-H), and 7.0–7.9 (8H, m, ArH); δ_{C} (CDCl₃) 44.68 (t, C-3), 78.76 (d, C-2), 115.62 (dd, $^2J_{\text{CF}}$ 21.2Hz, C-3' and C-5'), 117.93 (d, C-8), 120.79 (s, C-4a), 121.58 (d, C-6), 126.91 (d, C-5), 127.91 (dd, $^2J_{\text{CF}}$ 8.2Hz, C-2C-6'), 134.54 (sd, $^3J_{\text{CF}}$ 3.0Hz, C-1'), 136.05 (d, C-7), 161.66 (s, C-8a), 162.43 (sd, $^4J_{\text{CF}}$ 303.1Hz, C-4'), and 191.36 (s, C-4).

2,3-Dihydro-2-phenyl-4H-tetrazolo[1,5-d]-1,4-benzoxazepine (21) and 2,3-dihydro-2-phenyl-1,4-benzoxazepin-5(4H)-one [(18), R = Ph].³⁰ Trimethylsilyl azide (TMS-N₃) (1.6g, 74mmol) was added to a solution of 2,3-dihydro-2-phenyl-4H-1-benzopyran-4-one (1) (2g, 9mmol) in trifluoroacetic acid (TFA) (13mL) at room temperature under nitrogen and the resulting solution was stirred for 3d. Unreacted TMS-N₃ and TFA were removed *in vacuo* and the residue was chromatographed [flash chromatography; elution with hexane-EtOAc (1:1)] to afford three fractions, *viz.*,

- i) starting material;
- ii) 2,3-dihydro-2-phenyl-4H-tetrazolo[1,5-d]-1,4-benzoxazepine (21) (60mg, 3%), m.p. 136° C (from EtOH) (Lit.³⁰ 137° C); δ_{H} (500MHz, CDCl₃) 4.7 (1H, dd, *J* 9.8 and 14.6Hz, 3-H), 5.0 (1H, d, *J* 14.6Hz, 3-H), 5.2 (1H, d, *J* 9.7Hz, 2-H), and 7.1–8.5 (9H, m, ArH); δ_{C} (CDCl₃) 55.98 (t, C-3), 78.71 (d, C-2), 112.82 (s, C-5a), 121.34 (d, C-9), 123.75 (d, C-7), 125.93 (d, C-2' and C-6'), 128.88 (d, C-3' and C-5'), 129.02 (d, C-4'), 130.13 (d, C-6), 133.03 (d, C-8), 136.22 (s, C-1'), 151.69 (s, C-9a), and 156.64 (s, C-5); *m/z* 264 (M⁺, 2%), 235 (3), 220 (5), 219 (12), 209 (12), 208 (5), 180 (4), 152 (4), 135 (38), 117 (22),

105 (11), 104 (39), 103 (43), and 77 (100); and

iii) 2,3-dihydro-2-phenyl-1,4-benzoxazepin-5(4H)-one [(18), R = Ph] (0.54g, 25%), m.p. 125° C (from CH₂Cl₂-hexane) (Lit ³⁰ 127° C); δ_{H} (500MHz, CDCl₃) 3.5 (1H, dq, *J* 5.6, 6.6, and 15.5Hz, 3-H), 3.6 (1H, dq, *J* 3.5, 6.3, and 15.4Hz, 3-H), 5.4 (1H, dd, *J* 3.4 and 6.7Hz, 2-H), 7.0-7.8 (9H, m, ArH), and 8.2 (1H, br, NH); δ_{C} (CDCl₃) 46.08 (t, C-3), 85.87 (d, C-2), 122.29 (d, C-9), 123.41 (d, C-7), 125.73 (s, C-5a), 126.15 (d, C-2' and C-6'), 128.27 (d, C-4'), 128.46 (d, C-3' and C-5'), 130.75 (d, C-6), 133.12 (d, C-8), 138.93 (s, C-1'), 154.41 (s, C-9a), and 171.17 (s, C-5); *m/z* 239 (M⁺, 5%), 210 (5), 181 (16), 152 (5), 148 (8), 121 (47), and 119 (100).

8-Bromo-2,3-dihydro-2-phenyl-4H-tetrazolo[1,5-d]-1,4-benzoxazepine (75) and *8-bromo-2,3-dihydro-2-phenyl-1,4-benzoxazepin-5(4H)-one* (74). ³⁰

The experimental procedure employed for the synthesis of 2,3-dihydro-2-phenyl-4H-tetrazolo[1,5-d]-1,4-benzoxazepine (21) and 2,3-dihydro-2-phenyl-1,4-benzoxazepin-5(4H)-one [(18), R = Ph] was followed using TMS-N₃ (1.4mL, 10mmol) and 7-bromo-2,3-dihydro-2-phenyl-4H-1-benzopyran-4-one (63) (2g, 6.6mmol) in TFA (11mL). Work-up and flash chromatography [elution first with toluene to remove starting material and then with hexane-EtOAc (1:1) to effect separation of the two products] afforded three fractions, *viz.*,

i) starting material;

ii) *8-bromo-2,3-dihydro-2-phenyl-4H-tetrazolo[1,5-d]-1,4-benzoxazepine* (75) (167mg, 7.4%), m.p. 149° C (from EtOH) (Found: C, 52.1; H, 3.4; N, 16.55. C₁₅H₁₁BrN₄O requires C, 52.5; H, 3.2, N, 16.3%); δ_{H} (300MHz, CDCl₃) 4.8 (1H, dd, *J* 9.7 and 14.7Hz, 3-H), 5.1 (1H, dd, *J* 1.4 and 14.7Hz, 3-H), 5.2 (1H, dd, *J* 1.2 and 9.6Hz, 2-H), and 7.2-8.3 (8H, m, ArH); δ_{C} (CDCl₃) 55.98 (t, C-3), 79.24 (d, C-2), 111.97 (s, C-5a), 124.73 (d, C-6), 126.02 (d, C-2'

and C-6'), 126.85 (s, C-8), 127.35 (d, C-7), 129.13 (d, C-3' and C-5'), 129.40 (d, C-4') 131.28 (d, C-6), 135.79 (s, C-1'), 151.32 (s, C-9a), and 156.98 (s, C-5); m/z 342 (M^+ , 19%), 313 (17), 298 (23), 297 (58), 287 (43), 286 (13), 258 (1), 212 (44), 117 (68), 105 (21), 104 (100), and 103 (98); and

iii) *8-bromo-2,3-dihydro-2-phenyl-1,4-benzoxazepin-5(4H)-one* (74) (0.9g, 43%), m.p. 156° C (from EtOH) (Found: C, 56.9; H, 3.75; N, 4.6. $C_{15}H_{12}BrNO_2$ requires C, 56.6; H, 3.8; N, 4.4%); δ_H (300MHz, $CDCl_3$) 3.4–3.6 (2H, m, 3-H), 5.3 (1H, dd, J 3.5 and 6.3Hz, 2-H), and 7.1–7.6 (9H, m, ArH and NH); δ_C ($CDCl_3$) 46.43 (t, C-3), 85.97 (d, C-2), 123.90 (s, C-5a), 125.30 (d, 126.12 (d, C-2' and C-6'), 126.67 (d, C-7), 127.02 (s, C-8), 128.64 (d, C-4'), 128.73 (d, C-3' and C-5'), 132.51 (d, C-6), 138.47 (s, C-1'), 155.25 (s, C-9a), and 170.01 (s, C-5); m/z 317 (M^+ , 13%), 288 (14), 259 (15), 230 (0.1), 226 (5), 199 (17), 119 (100).

8-Chloro-2,3-dihydro-2-phenyl-4H-tetrazolo[1,5-d]-1,4-benzoxazepine (77) and *8-chloro-2,3-dihydro-2-phenyl-1,4-benzoxazepin-5(4H)-one* (76).³⁰ The experimental procedure employed for the synthesis of 2,3-dihydro-2-phenyl-4H-tetrazolo[1,5-d]-1,4-benzoxazepine (21) and 2,3-dihydro-2-phenyl-1,4-benzoxazepin-5(4H)-one [(18), R = Ph] was followed using $TMS-N_3$ (1.6mL, 12mmol) and 7-chloro-2,3-dihydro-2-phenyl-4H-1-benzopyran-4-one (64) (2g, 7.7mmol) in TFA (12.4mL). Work-up and flash chromatography [elution first with toluene to remove starting material and then with hexane-EtOAc (1:1) to effect separation of the two products] afforded three fractions, *viz.*,

i) starting material;

ii) *8-chloro-2,3-dihydro-2-phenyl-4H-tetrazolo[1,5-d]-1,4-benzoxazepine* (77) (126mg, 5.5%), m.p. 144° C (from EtOH) (Found: C, 60.0; H, 3.7; N, 19.6. $C_{15}H_{11}ClN_4O$ requires C, 60.3; H, 3.7, N, 18.75%); δ_H (300MHz, $CDCl_3$) 4.8

(1H, dd, J 9.5 and 14.5Hz, 3-H), 5.1 (1H, dd, J 1.5 and 14.5Hz, 3-H), 5.2 (1H, dd, J 1.5 and 9.5 Hz, 2-H), and 7.2–8.6 (8H, m, ArH); δ_C (CDCl₃) 56.09 (t, C-3), 79.30 (d, C-2), 111.49 (s, C-5a), 121.74 (d, C-9), 124.54 (d, C-7), 125.94 (d, C-2' and C-6'), 129.12 (d, C-3' and C-5'), 129.42 (C-4'), 131.28 (d, C-6), 135.68 (s, C-1'), 138.77 (s, C-8), 151.21 (s, C-9a), and 156.99 (C-5); m/z 298 (M⁺, 6%), 269 (7), 254 (11), 253 (36), 243 (21), 242 (6), 214 (2), 186 (0.2), 168 (26), 117 (29), 105 (10), 104 (52), 103 (61), and 77 (100); and

iii) *8-chloro-2,3-dihydro-2-phenyl-1,4-benzoxazepin-5(4H)-one* (76) (859mg, 41%), m.p. 146^o C (from EtOH) (Found: C, 66.0; H, 4.0; N, 5.1. C₁₅H₁₂ClNO₂ requires C, 65.8; H, 4.4; N, 5.1%); δ_H (300MHz, CDCl₃) 3.5–3.8 (2H, m, 3-H), 5.4–5.5 (1H, m, 2-H), and 7.1–7.9 (9H, m, ArH and NH); δ_C (CDCl₃) 47.06 (t, C-3), 85.57 (d, C-2), 122.33 (d, C-9), 123.87 (d, C-7) 126.05 (d, C-2' and C-6'), 126.33 (s, C-5a), 128.77 (d, C-3', C-4', and C-5'), 132.50 (d, C-6), 138.03 (s, C-1'), 139.59 (s, C-8), 155.71 (s, C-9a), and 169.59 (s, C-5); m/z 273 (M⁺, 9%), 244 (10), 215 (17), 186 (0.2), 182 (5), 155 (18), and 119 (100).

8-Fluoro-2,3-dihydro-2-phenyl-4H-tetrazolo[1,5-d]-1,4-benzoxazepine (79) and *8-fluoro-2,3-dihydro-2-phenyl-1,4-benzoxazepin-5(4H)-one* (78).³⁰ The experimental procedure employed for the synthesis of 2,3-dihydro-2-phenyl-4H-tetrazolo[1,5-d]-1,4-benzoxazepine (21) and 2,3-dihydro-2-phenyl-1,4-benzoxazepin-5(4H)-one [(18), R = Ph] was followed using TMS-N₃ (4.2mL, 32mmol) and 7-fluoro-2,3-dihydro-2-phenyl-4H-1-benzopyran-4-one (65) (5g, 21mmol) in TFA (33mL). Work-up and flash chromatography [elution first with toluene to remove starting material and then with hexane-EtOAc (1:1) to effect separation of the two products] afforded three fractions, *viz.*,

ii) *8-fluoro-2,3-dihydro-2-phenyl-4H-tetrazolo[1,5-d]-1,4-benzoxazepine* (79) (1.6g, 28%), m.p. 157° C (from EtOH) (Found: C, 63.8; H, 3.9; N, 20.2. $C_{15}H_{11}FN_4O$ requires C, 63.8; H, 3.9, N, 19.85%); δ_H (300MHz, $CDCl_3$) 4.8 (1H, dd, J 9.7 and 14.8, 3-H), 5.1 (1H, dd, J 1.3 and 14.6Hz, 3-H), 5.2 (1H, dd, J 1.3 and 9.6Hz, 2-H), and 6.7–8.5 (8H, m, ArH); δ_C ($CDCl_3$) 55.9 (t, C-3), 79.3 (d, C-2), 108.6 (dd, $^2J_{CF}$ 24.0Hz, C-9), 111. (dd, $^2J_{CF}$ 22.2Hz, C-7), 126.0 (d, C-2' and C-6'), 129.1 (d, C-3' and C-5'), 129.38 (d, C-4'), 132.2 (dd, $^3J_{CF}$ 10.0Hz, C-6), 135.9 (s, C-1'), 151.3 (s, C-9a), 158.2 (s, C-5), and 165.2 (sd, $^1J_{CF}$ 247.5Hz, C-8); $\dagger\dagger m/z$ 282 (18), 253 (28), 238 (32), 237 (100), 227 (47), 226 (18), 198 (7), 170 (4), 152 (60), 117 (30), 105 (9), 104 (45), and 103 (39); and

iii) *8-fluoro-2,3-dihydro-2-phenyl-1,4-benzoxazepin-5(4H)-one* (78) (1.7g, 32%), m.p. 129° C (from EtOH) (Found: C, 70.2; H, 4.7; N, 5.5. $C_{15}H_{12}FNO_2$ requires C, 70.0; H, 4.7; N, 5.4%); δ_H (300MHz, $CDCl_3$) 3.5–3.6 (2H, m, 3-H), 5.4–5.5 (1H, m, 2-H), and 6.7–7.9 (9H, m, ArH and NH); δ_C ($CDCl_3$) 46.51 (t, C-3), 85.96 (d, C-2), 109.15 (dd, $^2J_{CF}$ 23.4Hz, C-9), 110.97 (dd, $^2J_{CF}$ 21.8Hz, C-7), 121.15 (s, C-5a), 126.13 (d, C-2' and C-6'), 128.62 (d, C-4'), 128.72 (d, C3' and C-5'), 133.31 (dd, $^3J_{CF}$ 10.3Hz, C-6), 138.55 (s, C-1'), 156.39 (sd, $^3J_{CF}$ 12.0Hz, C-9a), 165.60 (sd, $^1J_{CF}$ 252.92, C-8), and 170.02 (s, C-5); m/z 257 (M^+ , 38%), 228 (48), 199 (57), 170 (6), 166 (13), 139 (51), and 119 (100).

2-(4-Bromophenyl)-2,3-dihydro-4H-tetrazolo[1,5-d]-1,4-benzoxazepine (81) and *2-(4-bromophenyl)-2,3-dihydro-1,4-benzoxazepin-5(4H)-one* (80).³⁰

The experimental procedure employed for the synthesis of 2,3-dihydro-2-phenyl-4H-tetrazolo[1,5-d]-1,4-benzoxazepine (21) and 2,3-dihydro-2-phenyl-1,4-benzoxazepin-5(4H)-one [(18), R = Ph] was

$\dagger\dagger$ The C-5a signal could not be detected in this spectrum.

followed using TMS-N₃ (0.7mL, 5.0mmol) and 2-(4-bromophenyl)-2,3-dihydro-4H-1-benzopyran-4-one (66) (1.0g, 3.3mmol) in TFA (5.3mL). Work-up and flash chromatography [elution first with toluene to remove starting material and then with hexane-EtOAc (1:1) to effect separation of the two products] afforded three fractions, *viz.*,

i) starting material;

ii) 2-(4-bromophenyl)-2,3-dihydro-4H-tetrazolo[1,5-d]-1,4-benzoxazepine (81) (115mg, 10%), m.p. 182° C (from EtOH); δ_{H} (300MHz, CDCl₃) 4.8 (1H, dd, *J* 9.5 and 15.0Hz, 3-H), 5.1 (1H, dd, *J* 1.2 and 15Hz, 3-H), 5.2 (1H, dd, *J* 1.2 and 9.5Hz, 2-H), and 7.1–8.6 (8H, m, ArH); δ_{C} (CDCl₃) 56.04 (t, C-3), 78.34 (d, C-2), 112.85 (s, C-5a), 121.42 (d, C-9), 123.38 (C-4'), 124.19 (d, C-7), 127.64 (d, C-2' and C-6'), 130.44 (d, C-6), 132.25 (d, C-3' and C-5'), 133.31 (d, C-8), 135.16 (s, C-1'), 151.80 (s, C-9a), and 156.43 (s, C-5); *m/z* 342 (M⁺, 4%), 313 (5), 298 (8), 297 (24), 287 (15), 286 (2), 258 (7), 182 (13), 181 (4), 152 (7), 139 (1), 134 (91), 117 (17), and 77 (100); and

iii) 2-(4-bromophenyl)-2,3-dihydro-1,4-benzoxazepin-5(4H)-one (80) (415mg, 40%), m.p. 142° C (from EtOH) (Found: C, 56.9; H, 3.75; N, 4.7. C₁₅H₁₂BrNO₂ requires C, 56.6; H, 3.8; N, 4.4%); δ_{H} (300MHz, CDCl₃) 3.4–3.7 (2H, m, 3-H), 5.3–5.5 (1H, m, 2-H), and 7.0–7.9 (9H, m, ArH and NH); δ_{C} (CDCl₃) 45.96 (t, C-3), 85.13 (d, C-2), 122.29 (d, C-9), 122.39 (s, C-4'), 123.89 (d, C-7), 125.90 (s, C-5a), 127.97 (d, C-2' and C-6'), 130.84 (d, C-6), 131.71 (d, C-3' and C-5'), 133.35 (d, C-8), 138.01 (s, C-1'), 154.22 (s, C-9a), and 171.16 (s, C-5); 317 (M⁺, 26%), 288 (18), 259 (11), 197 (93), 152 (16), 148 (21), and 121 (100).

2-(4-Chlorophenyl)-2,3-dihydro-4H-tetrazolo[1,5-d]-1,4-benzoxazepine (83)

and 2-(4-chlorophenyl)-2,3-dihydro-1,4-benzoxazepin-5(4H)-one (82).³⁰

The experimental procedure employed for the synthesis of

2,3-dihydro-2-phenyl-4H-tetrazolo[1,5-d]-1,4-benzoxazepine (21) and 2,3-dihydro-2-phenyl-1,4-benzoxazepin-5(4H)-one [(18), R = Ph] was followed using TMS-N₃ (1.2mL, 8.6mmol) and 2-(4-chlorophenyl)-2,3-dihydro-4H-1-benzopyran-4-one (67) (1.5g, 5.8mmol) in TFA (9.3mL). Work-up and flash chromatography [elution first with toluene to remove starting material and then with hexane-EtOAc (1:1) to effect separation of the two products] afforded three fractions, *viz.*,

i) starting material;

ii) 2-(4-chlorophenyl)-2,3-dihydro-4H-tetrazolo[1,5-d]-1,4-benzoxazepine (83), (176mg, 10%), m.p. 168° C (from EtOH) (Found: C, 60.4; H, 3.6; N, 19.1. C₁₅H₁₁ClN₄O requires C, 60.3; H, 3.7, N, 18.75%); δ_{H} (300MHz, CDCl₃) 4.8 (1H, dd, *J* 9.5 and 14.0Hz, 3-H), 5.1 (1H, dd, *J* 1.8 and 14.0Hz, 3-H), 5.2 (1H, dd, *J* 1.8 and 9.5Hz, 2-H), and 7.1-8.6 (8H, m, ArH); δ_{C} (CDCl₃) 56.11 (t, C-3), 78.29, (d, C-2), 112.85 (s, C-5a), 121.42 (d, C-9), 124.17 (d, C-7), 127.36 (d, C-2' and C-6'), 129.29 (d, C-3' and C-5'), 130.45 (d, C-6), 133.30 (d, C-8), 134.66 (s, C-4'), 135.24 (s, C-1'), 151.80 (s, C-9a), and 156.44 (s, C-5); *m/z* 298 (M⁺, 13%), 269 (20), 254 (24), 253 (69), 243 (35), 214 (3), 152 (11), 139 (8), 138 (30), 137 (7), 134 (100), and 117 (10); and

iii) impure 2-(4-chlorophenyl)-2,3-dihydro-1,4-benzoxazepin-5(4H)-one (82) which was chromatographed [preparative layer chromatography (p.l.c.) on MERK Kieselgel 60PF₂₅₄; elution with hexane-EtOAc (40:60)] (268mg, 17%); δ_{H} (300MHz, CDCl₃) 3.4-3.6 (1H, m, 3-H), 3.6-3.8 (1H, m, 3-H), 5.4 (1H, dd, *J* 3.0 and 6.0Hz, 2-H), and 7.0-7.9 (9H, m, ArH and NH); δ_{C} (CDCl₃) 46.77 (t, C-3), 84.78 (d, C-2), 122.33 (d, C-9), 123.90 (d, C-7), 125.22 (s, C-5a), 127.58 (d, C-2' and C-6'), 128.87 (d, C-3' and C-5'), 131.05 (d, C-6), 134.08 (d, C-8), 134.45 (s, C-4'), 137.00 (s, C-1'), 154.76 (s, C-9a), and 170.98 (s, C-5); 273 (M⁺, 19%), 244 (17), 215 (13), 153 (100), 152 (11), 148 (11), and 121 (49).

2-(4-Fluorophenyl)-2,3-dihydro-4H-tetrazolo[1,5-d]-1,4-benzoxazepine (85) and *2-(4-fluorophenyl)-2,3-dihydro-1,4-benzoxazepin-5(4H)-one* (84).³⁰

The experimental procedure employed for the synthesis of 2,3-dihydro-2-phenyl-4H-tetrazolo[1,5-d]-1,4-benzoxazepine (21) and 2,3-dihydro-2-phenyl-1,4-benzoxazepin-5(4H)-one [(18), R = Ph] was followed using TMS-N₃ (1.3mL, 8.6mmol) and 2-(4-fluorophenyl)-2,3-dihydro-4H-1-benzopyran-4-one (68) (1.5g, 6.2mmol) in TFA (10.0mL). Work-up and flash chromatography [elution first with toluene to remove starting material and then with hexane-EtOAc (1:1) to effect separation of the two products] afforded three fractions, *viz.*,

i) starting material;

ii) material presumed to be 2-(4-fluorophenyl)-2,3-dihydro-4H-tetrazolo[1,5-d]-1,4-benzoxazepine (85), (147mg, 8%), m.p. 182° C (from EtOH); spectroscopic data not to hand.

iii) impure *2-(4-fluorophenyl)-2,3-dihydro-1,4-benzoxazepin-5(4H)-one* (84) which was chromatographed [p.l.c. on MERK Kieselgel 60PF₂₅₄; elution with hexane-EtOAc (1:1)] (289mg, 18%), m.p. 183° C (from EtOH) (Found: C, 69.8; H, 4.7; N, 5.6. C₁₅H₁₂FNO₂ requires C, 70.0; H, 4.7; N, 5.4%); δ_H (60 MHz) 3.4–3.7 (2H,m,3-H), 5.4 (1H,t,2-H), and 6.9–8.4 (8H,m,ArH).

2,3-Dihydro-4-(hydroxyimino)-2-phenyl-4H-1-benzopyran (73). K₂CO₃ (1.3g, 9.6mmol) and NH₂OH·HCl (0.7g, 9.6mmol) were added to a solution of 2,3-dihydro-2-phenyl-4H-1-benzopyran-4-one (1) (1.0g, 4.5mmol) in EtOH (25mL) and the resulting mixture was boiled under reflux for 6h. The reaction mixture was poured into cold H₂O (50mL), and the precipitate which formed overnight was filtered, dried *in vacuo*, and recrystallised twice first in benzene-petroleum ether (b.p. 40–60° C), and then neat benzene to afford 2,3-dihydro-4-(hydroxyimino)-2-phenyl-4H-1-benzopyran (73) (0.73g,

68%), m.p. 162–164°C; δ_{H} (CDCl_3 -DMSO- d_6) 2.7 (1H, dd, J 11.9 and 17.0, 3-H), 3.4 (1H, dd, J 3.2 and 17.1, 3-H), 5.1 (1H, dd, J 3.2 and 11.7, 2-H), 6.9–7.9 (9H, m, ArH), and 11.2 (1H, s, NOH); δ_{C} (CDCl_3 -DMSO- d_6) 29.82 (t, C-3), 76.30 (d, C-2), 117.41 (d, C-8), 118.87 (s, C-4a), 121.06 (d, C-6), 123.20 (d, C-5), 126.02 (d, C-2' and C-6'), 127.86 (d, C-4'), 128.20 (d, C-3' and C-5'), 130.11 (d, C-7), 139.85 (s, C-1'), 147.04 (s, C-8a), and 155.56 (s, C-4); m/z 239 (M^+ , 100%).

Beckmann rearrangement of 2,3-Dihydro-4-(hydroxyimino)-2-phenyl-4H-1-benzopyran (73).

Attempted method 1. ²⁰

2,3-Dihydro-4-(hydroxyimino)-2-phenyl-4H-1-benzopyran (73) (3.0g, 12.6mmol) was stirred with polyphosphoric acid (22mL) at 130–135°C for 15mins., poured into H_2O (ca. 100mL), and extracted with CHCl_3 (3 × 50mL). The organic phase was dried (anhyd. Na_2SO_4) and evaporated to afford an oil (2.0g). T.l.c. analysis revealed that the major constituent of the oil was 2,3-dihydro-2-phenyl-4H-1-benzopyran-4-one (1) together with a small amount of the oxime starting material (73).

Attempted method 2. ^{28,67}

2,3-Dihydro-4-(hydroxyimino)-2-phenyl-4H-1-benzopyran (73) (3.0g, 12.6mmol) and PCl_5 (6g) in Et_2O (200mL) were stirred on ice for 0.5h. The reaction mixture was then allowed to warm to room temperature and stirred for a further 3h. The resulting mixture was then poured onto ice, extracted with EtOAc (3 × 30mL), dried (anhyd. MgSO_4), and evaporated to afford a

black tar. T.l.c. analysis of the tar showed that there were seven components in the mixture. Flash chromatography [elution with hexane–EtOAc (3:1)] was attempted but no separation of the components could be effected.

N-Benzoyl-2,3-dihydro-2-phenyl-1,4-benzoxazepin-5(4H)-one (89).

Lithium diisopropylamide (LDA) was prepared *in situ* by the addition of butyllithium (3.1mL, 4.6mmol) to a solution of diisopropylamine (0.7mL, 4.6mmol) in dry THF (25mL), which was maintained at a temperature of -30°C . The resulting mixture was allowed to stir at this temperature for 1h., cooled to -78°C , and then 2,3-dihydro-2-phenyl-1,4-benzoxazepin-5(4H)-one (1.0g, 4.2mmol) in THF (5mL) was added. After stirring the reaction mixture for 1h at -78°C , benzoyl chloride (0.5mL, 4.2mmol) in THF (5mL) was added, whereafter it was allowed to warm to room temperature over 3–4h. The reaction mixture was stirred for a further 12h. to ensure that the reaction had run to completion, whereupon it was poured into 1% aq. NaHCO_3 , from which the product crystallised. Recrystallisation from EtOAc afforded *N*-benzoyl-2,3-dihydro-2-phenyl-1,4-benzoxazepin-5(4H)-one (89) (1.0g, 70%), m.p. $155\text{--}157^{\circ}\text{C}$; δ_{H} (500MHz, CDCl_3) 4.3 (1H, dd, J 7.6 and 15.3Hz, 3-H), 4.6 (1H, dd, J 4.3 and 15.3 Hz, 3-H), 5.6 (1H, dd, J 4.3 and 7.6 Hz, 2-H), and 7.0–7.9 (14H, m, ArH); δ_{C} (CDCl_3); m/z 344 (M^+ , 25%), 77 (100).

N-Benzoyl-2-bromo-2,3-dihydro-2-phenyl-1,4-benzoxazepin-5(4H)-one (90).

Attempted method 1.

A solution of *N*-benzoyl-2,3-dihydro-2-phenyl-1,4-benzoxazepin-5(4H)-one (89) (0.3g, 0.9mmol) in THF (10mL) was added to a solution of LDA

(1.0mmol) in THF (20mL) which had been generated *in situ* as above and the resulting mixture was allowed to stir for 1h. at -80°C . The reaction mixture was allowed to warm to room temperature and the solvent was removed *in vacuo*. The concentrate was extracted with EtOAc, dried (MgSO_4), evaporated, and recrystallised from EtOH to afford pale yellow crystals. T.l.c. analysis showed that the product and the starting material had the same R_f value, and ^1H n.m.r. spectroscopy proved that the product and the starting material were no different from each other.

Attempted method 2.

A solution of *N*-benzoyl-2,3-dihydro-2-phenyl-1,4-benzoxazepin-5(4H)-one (89) (1.0g, 2.9mmol) in THF (25mL) was added to a cold stirred solution of LDA (3.2mmol) (generated *in situ* as above) in THF (25mL). *N*-bromo-succinimide (0.6g, 3.2mmol) in THF (10mL) was added to the reaction mixture which was allowed to warm to room temperature and stirred overnight. The deep orange inorganic precipitate which had formed in the reaction mixture was filtered after the addition of 5% aq. NaHCO_3 (30mL). The organic layer was dried (MgSO_4), and the solvent was evaporated to afford a crude product which was proved by t.l.c. and ^1H n.m.r. spectroscopy to be starting material.

N-benzoyl-2-phenyl-1,4-benzoxazepin-5(4H)-one.

Attempted method. ⁷⁶

A solution of *N*-benzoyl-2,3-dihydro-2-phenyl-1,4-benzoxazepin-5(4H)-one (89) (1.0g, 2.9mmol) and SeO_2 (1.5g, 3.7mmol) in *t*-BuOH (40mL) was boiled under reflux in an inert atmosphere for 24h. Flash chromatography [elution,

first with hexane–EtOAc (1:1) and then with neat EtOAc] afforded starting material (89) and some hydrolysed product [(18), R = Ph]. No unsaturated compound could be detected.

4. REFERENCES

1. S.v. Kostanecki and V. Lampe, *Ber.*, 1904, *37*, 773.
2. S.v. Kostanecki, V. Lampe, and J. Tambor, *Ber.*, 1904, *37*, 1402.
3. J. Staunton in *Comprehensive Organic Chemistry*, ed. D. Barton and W.D. Ollis, Pergamon, Oxford, 1979, vol. 4, pp. 681–689.
4. T. Ueng and F.-C. Chen, *Proc. Natl. Sci. Council, Part 1 (Taiwan)*, 1976, *9*, 335.
5. O. Dann and G. Mylius, *Ann.*, 1954, *587*, 1. [CA 50:2560c]
6. V.T. Ramakrishnan and J. Kagan, *J. Org. Chem.*, 1970, *35*, 2901.
7. C.M. Christian and G.L. Amin, *J. Sci. Ind. Research*, 1955, *14B*, 421. [CA 50:11294e]
8. H. Simonis and C. Lear, *Ber.*, 1926, *59B*, 2908. [CA 21:1255]
9. E. Rakosi-David and R. Bognar, *Acta Univ. Debrecen*, 1961, *7*, 141. [CA 58:5617H]
10. J. Furlong and N.S. Nudelman, *J. Chem. Soc., Perkin Trans. 2*, 1985, 633.
11. N.S. Poonia, K. Chhabra, K. Kumar, and V.W. Bhagwat, *J. Org. Chem.*, 1977, *42*, 3311.
12. C.P. Dutta and L.P.K. Roy, *Indian J. Chem.*, 1975, *13(4)*, 425. [CA 83:96950x]
13. F.C. Chen, T.S. Chen, and T. Ueng, *J. Chinese Chem. Soc. (Taiwan)*, 1962, *9(4)*, 308. [CA 60:10639c]
14. S.W. Swathe and K.N. Wadodkar, *Indian J. Chem, Sect. B*, 1982, *21B(2)*, 153. [CA 97:55530f]
15. R.L. Shriner and T. Kurosawa, *J. Am. Chem. Soc.*, 1930, *52*, 2538.
16. T. Oyamada, *J. Chem. Soc. Japan*, 1943, *64*, 864 [CA 41:3798d]
17. H. Tatsuta, *J. Chem. Soc. Japan*, 1942, *63*, 935. [CA 41:4128a]
18. R. Neu, *Arch. Pharm*, 1960, *293*, 169. [CA 55:24734c]

19. N. Narasimhachari and E.V. Rudloff, *Can. J. Chem.*, 1962, *40*, 1123. [CA 57:6588f]
20. D. Huckle, I.M. Lockhart, and M. Wright, *J. Chem. Soc.*, 1965, 1137.
21. D. Evans and I.M. Lockhart, *J. Chem. Soc.*, 1965, 4806
22. P.T. Lansbury and N.R. Mancuso, *J. Am. Chem. Soc.*, 1966, *88*(6), 1205.
23. U.T. Bhalerao and G. Thyagarajan, *Can. J. Chem.*, 1968, *46*, 3367.
24. J. Krapcho and C.F. Turk, U.S. Pat. 3309361 (1967). [CA 68:P2930f]
25. I.M. Lockhart, *Chem. Ind. (London)*, 1968, (52), 1844.
26. D. Misiti and V. Rimatori, *Tetrahedron Lett.*, 1970, (12), 947.
27. D. Misiti, *Ann. Ist. Super. Sanita*, 1973, *9* (Pt. 2-3), 174.
28. D. Misiti and V. Rimatori, *Ann. Ist. Super. Sanita*, 1973, *9* (Pt. 2-3), 150.
29. A. Levai and R. Bognar, *Acta Chim. Acad. Sci. Hung.*, 1978, *97*(1), 77.
30. G. Litkei and T. Patonay, *Acta Chimica Hungarica*, 1983, *114* (1), 47.
31. H.M. Nour El Din and H.D. Atteya Shawki, *Bull. Fac. Pharm., Cairo Univ.*, 1970, *9*(1), 245.
32. H.M. Nour El Din and H.D. Atteya Shawki, *Bull. Fac. Pharm., Cairo Univ.*, 1970, *9*(1), 253.
33. K. Schenker, Ger. Pat. 1912546 (1969). [CA 72:31861x]
34. K. Schenker, Swiss Pat. 505850 (1971). [CA 75:98600s]
35. M.K. Raja, K. Rajeshwar, and C. Sudhakar, *Acta Cienc. Indica, [Ser.] Chem.*, 1984, *10*(4), 267.
36. M.E. Derieg and L.H. Sternbach, *J. Heterocyclic Chem.*, 1966, *3*, 237.
37. N.B. Pappano, S.E. Blanco, N.B. Debattista, R.F. Segovia, and F.H. Ferretti, *Commun. Biol.*, 1985, *4*(1), 23. [CA 104:31619d]
38. J.M. Edwards, R.F. Raffauf and P.W. Le Quesne, *J. Nat. Prod.*, 1979, *42*(1), 85.
39. C. Nishino, N. Enoki, S. Sato, J. Oya, Japanese Pat., 61137818 (1986). [CA 105:P183959y]

40. R. Laliberte, D. Campbell, and F. Bruderlein, *Can. J. Pharm. Sci.*, 1967, 2(2), 37. [CA 67:98058f]
41. K. Formanek, H. Holler, H. Janisch, and W. Kowak, *Pharm. Acta Helv.*, 1958, 33, 437. [CA 53:15380h]
43. N. Narasimhachari and T.R. Seshadri, *Proc. Indian Acad. Sci.*, 1948, 27A, 128. [CA 42:5604d]
44. C.G. Rimbault, U.K. Pat GB2145718 (1985). [104:50731a]
45. *Principles of Medicinal Chemistry, 2nd. Ed.*, ed. W.O. Foye, Lea and Febiger, USA, 1980, pp. 229–236.
46. H. Ashton, *New Scientist*, 6 May 1989, 52.
47. W. Haefely and W. Hunkeler, *European J. Anaesthesiology*, 1988, Supplement 2, 3.
48. H. Mohler and J.G. Richards, *European J. Anaesthesiology*, 1988, Supplement 2, 15.
49. E.R. Squibb, French Pat., 1552840 (1969). [CA 72:P31855y]
50. J. Bernstein, Brit. Pat., 1198853 (1970). [CA 73:77295q]
51. V.S. Andreichikov, L.A. Voronova, Z.D. Belykh, and A.N. Plaksina, U.S.S.R. Pat. 666799 (1979). [CA 93:71822a]
52. A.D. Cale, Jr, B.V. Franko, and A.C. Leonard, Eur. Pat. EP107930 (1984). [CA 101:P130726f]
53. A. Waefelaer, Ger. Pat., 2116222 (1971). [CA 76:75321]
54. W. Schindler and H. Blattner, Swiss Pat., 481128 (1969). [CA 72:90543]
55. J.D. Bryan, A.A Goldberg, and A.H. Wragg, *J. Chem. Soc.*, 1960, 1279.
56. F.C. Chen and C.T. Chang, *J. Chem. Soc.*, 1958, 146.
57. W.C. Still, M. Kahn, and A. Mitra, *J. Org. Chem.*, 1978, 43(14), 2923.
58. P.W. Freeman, S.T. Murphy, J.E. Nemorin, and W.C. Taylor, *Aust. J. Chem*, 1981, 34, 1779
59. A. Pelter, R.S. Ward, and T.I. Gray, *J. Chem. Soc., Perkin 1*, 1976, 247.

59. A. Pelter, R.S. Ward, and T.I. Gray, *J. Chem. Soc., Perkin 1*, 1976, 247.
60. A.H. Blatt, *Chem. Rev.*, 1933, 12, 215.
61. R.S. Monson and B.M. Broline, *Can. J. Chem.*, 1973, 51, 942.
62. E.C. Horning, V.L. Stromberg, and H.A. Lloyd, *J. Am. Chem. Soc.*, 1952, 74, 5153.
63. E.C. Horning and V.L. Stromberg, *J. Am. Chem. Soc.*, 1952, 74, 5151.
64. D.E. Pearson and R.M. Stone, *J. Am. Chem. Soc.*, 1961, 83, 1715.
65. K. Nagarajan, C.L. Kulkarni, and A. Venkateswarlu, *Indian Journal of Chemistry*, 1974, 12, 247.
66. S.G. Powell, *J. Am. Chem. Soc.*, 1923, 45, 2708.
67. A.H. Blatt, *J. Am. Chem. Soc.*, 1931, 53, 1133.
68. G.I. Koldobskii, G.F. Tereshchenko, E.S. Gerasimova, and L.I. Bagal, *Russian Chemical Reviews*, 1971, 40(10), 835.
69. P.A.S. Smith in *Molecular Rearrangements*, ed. P. Mayo, Wiley, New York, 1963, vol. 1, p.507.
70. P.A.S. Smith, *J. Am. Chem. Soc.*, 1948, 70, 320.
71. P.A.S. Smith and J.P. Horwitz, *J. Am. Chem. Soc.*, 1950, 72, 3718.
72. H. Duddeck and A. Levai, *Arch. Pharm.*, 1983, 316 (3), 100.
73. H.A. Silverwood and M. Orchin, *J. Org. Chem.*, 1962, 27, 3401.
74. W.T. House and M.T. Orchin, *J. Am. Chem. Soc.*, 1960, 82, 639.
75. L.F. Fieser, S. Rajagopalan, E. Wilson, and M. Tishler, *J. Am. Chem. Soc.*, 1951, 73, 4133.
76. S. Bernstein and R. Littel, *J. Am. Chem. Soc.*, 1960, 82, 1235.
77. T.G. Back, *J. Org. Chem.*, 1981, 46, 1442.
78. P.J. Brogden, C.D. Gabbutt, and J.D. Hepworth in *Comprehensive Heterocyclic Chemistry*, ed. A.R. Katritzky and C.W. Rees, Pergamon, Oxford, 1984, vol. 3, p. 618.
79. R.N. Butler in *Comprehensive Heterocyclic Chemistry* ed. A.R. Katritzky

80. D.H. Williams and I. Fleming, *Spectroscopic Methods in Organic Chemistry*, fourth edition, Macgraw–Hill, London, 1987, pp. 91–93
81. W. Mcfarlane, in *Techniques of Chemistry*, Vol. IV, second edition, ed. K.W. Bentley and G.W. Kirby, Wiley, New York, 1972, pp. 274–278.
82. D.W. Brown, A.J. Floyd and M. Sainsbury, *Organic Spectroscopy*, Wiley, Chichester, 1988, pp. 128–129.
83. Tripos associates, *Alchemy manual*.
84. W.J. Wohlleben, *Chem. Ber.*, 1909, 42, 4369.
85. C.T. Chang and F.C. Chen, *J. Chem. Soc.*, 1961, 3155.
86. P.L. Cheng, P. Fournari, and J. Tirouflet, *Bull. Soc. Chim. France*, 1963 (10), 2248, [CA 60:1683d].
87. F. Chin–Chen and C.–H. Yang, *J. Taiwan. Pharm. Assoc.*, 1951, 3, 39. [CA 49:2432h]
88. W.G. Clark and T.A. Geissman, *Pharmacol. Exptl. Therap.*, 1949, 95, 362. [CA 43:5117a]
89. G.M. Sheldrick, *Shelx 76, Program for Crystal Structure Determination*, Cambridge University, 1976.

5. APPENDICES

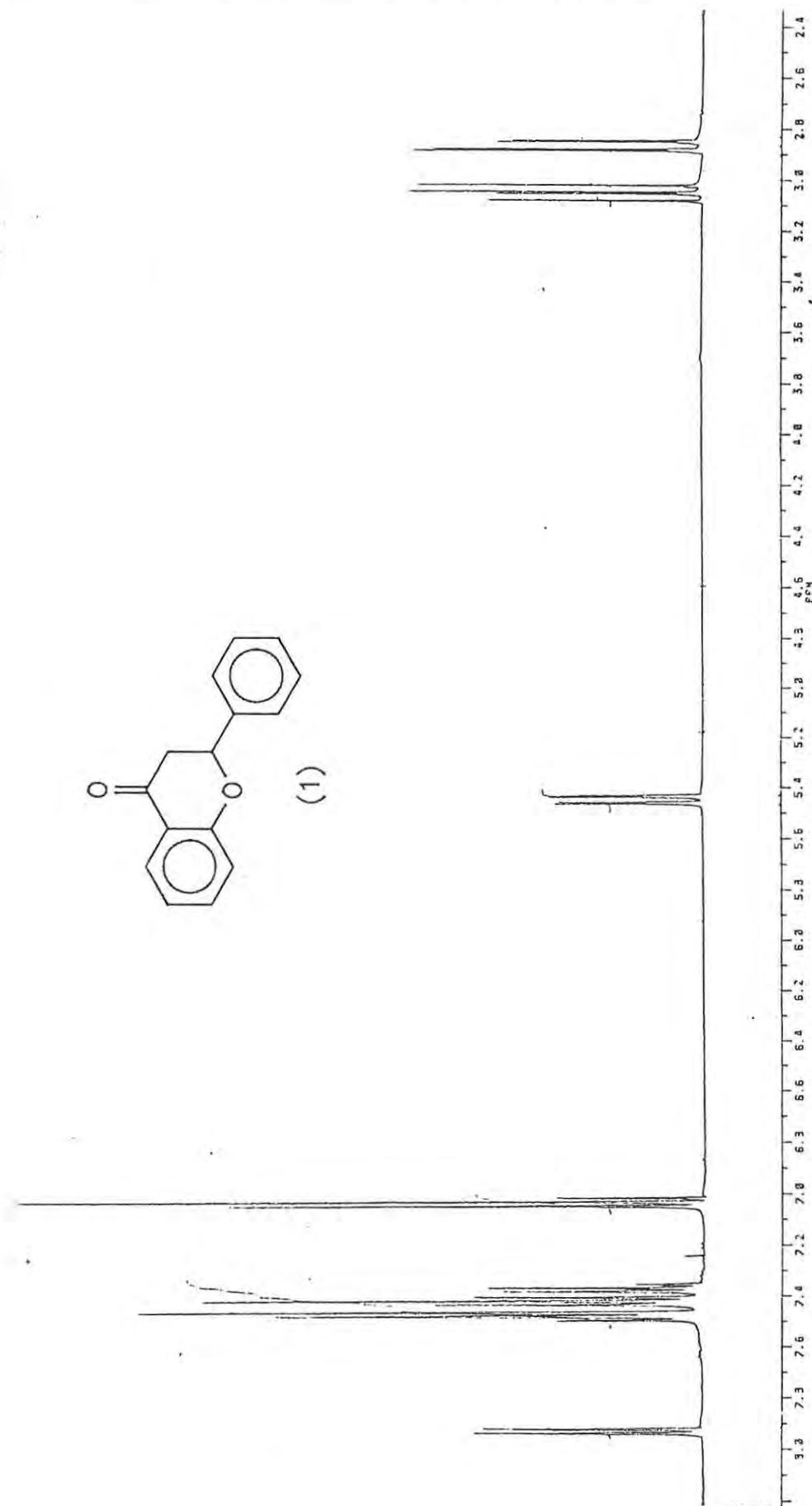
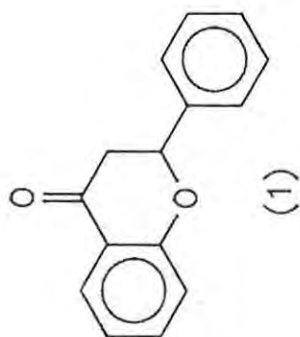
APPENDIX 1: Some sample ^1H and ^{13}C n.m.r. spectraSpectrum 1: ^1H n.m.r. spectrum of flavanone (1)

Spectrum 1: (1)

110 Spectrum of flavanone (1)

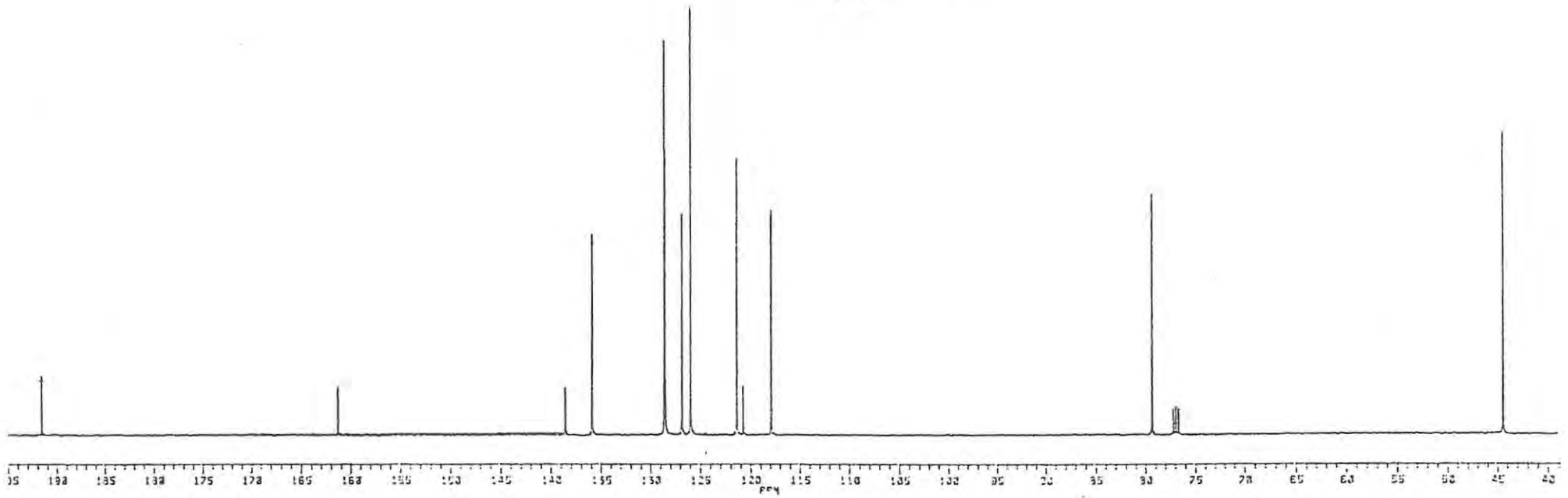
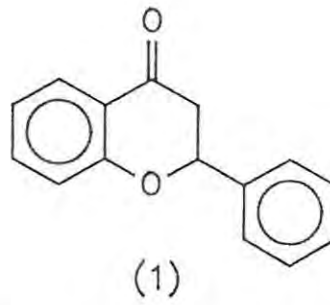

Spectrum 2: ^{13}C proton noise decoupled n.m.r. spectrum of flavanone (1)

Revised: (8/18), (10/11)

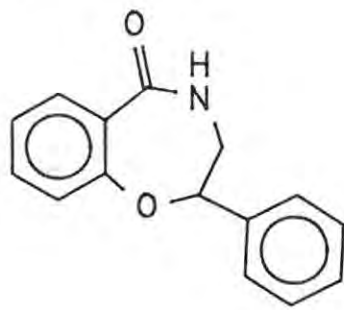

[(18), R = Ph]

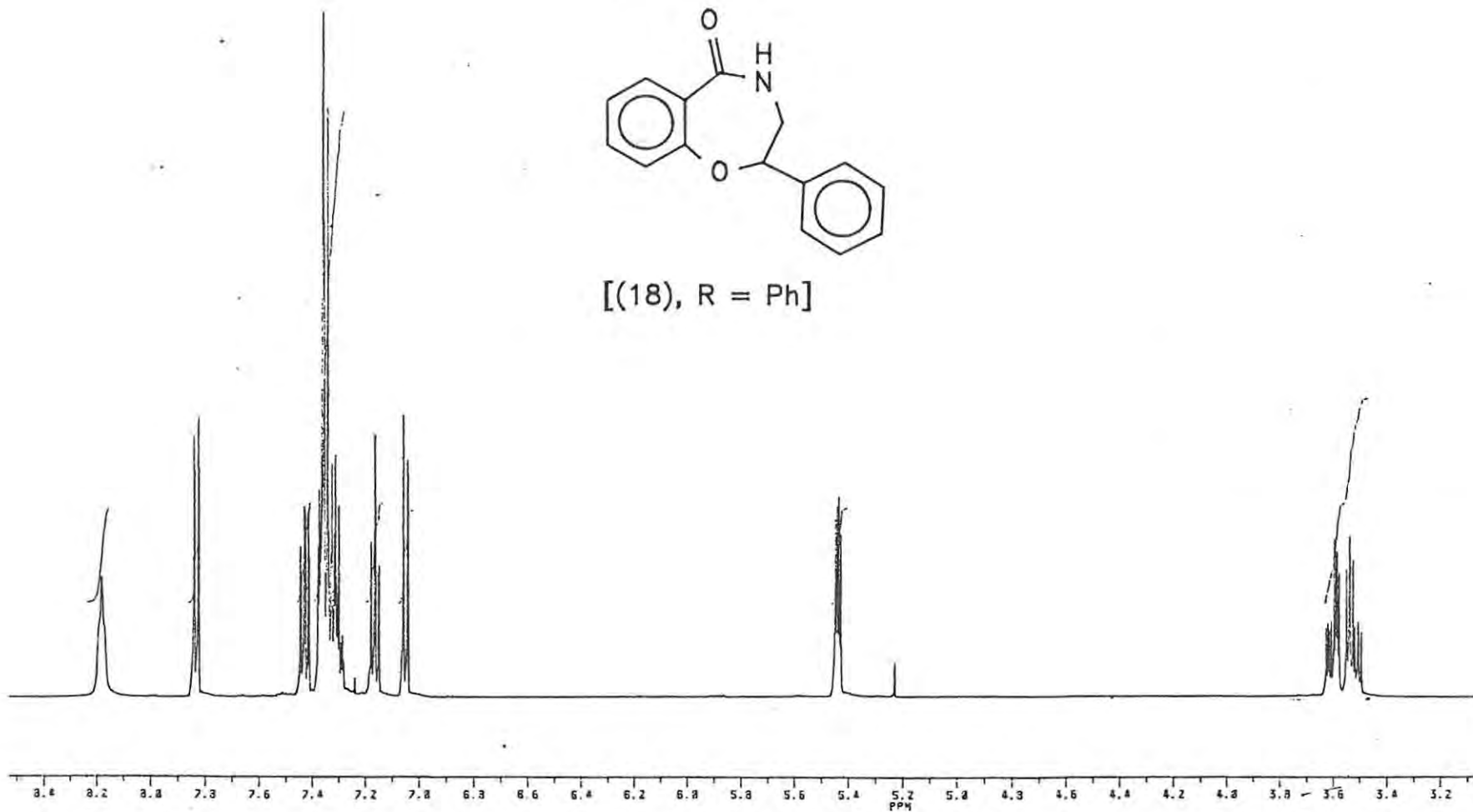

Spectrum 3: ¹H n.m.r. spectrum of
2,3-dihydro-2-phenyl-1,4-benzoxazepin-5(4H)-one [(18), R = Ph]

2nd ed. [(18), R = Ph]

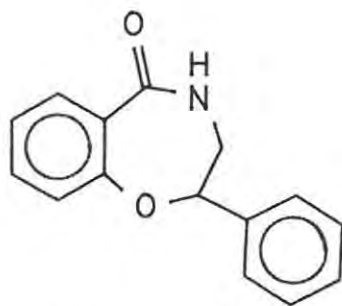

[(18), R = Ph]

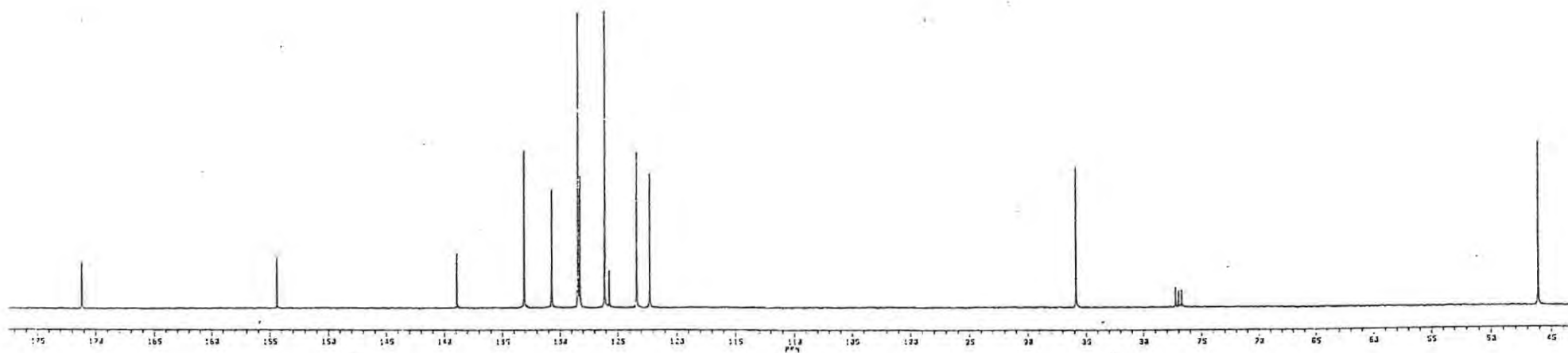

Spectrum 4: ¹³C proton noise decoupled n.m.r. spectrum of
2,3-dihydro-2-phenyl-1,4-benzoxazepin-5(4H)-one [(18), R = Ph]

Review of (21)

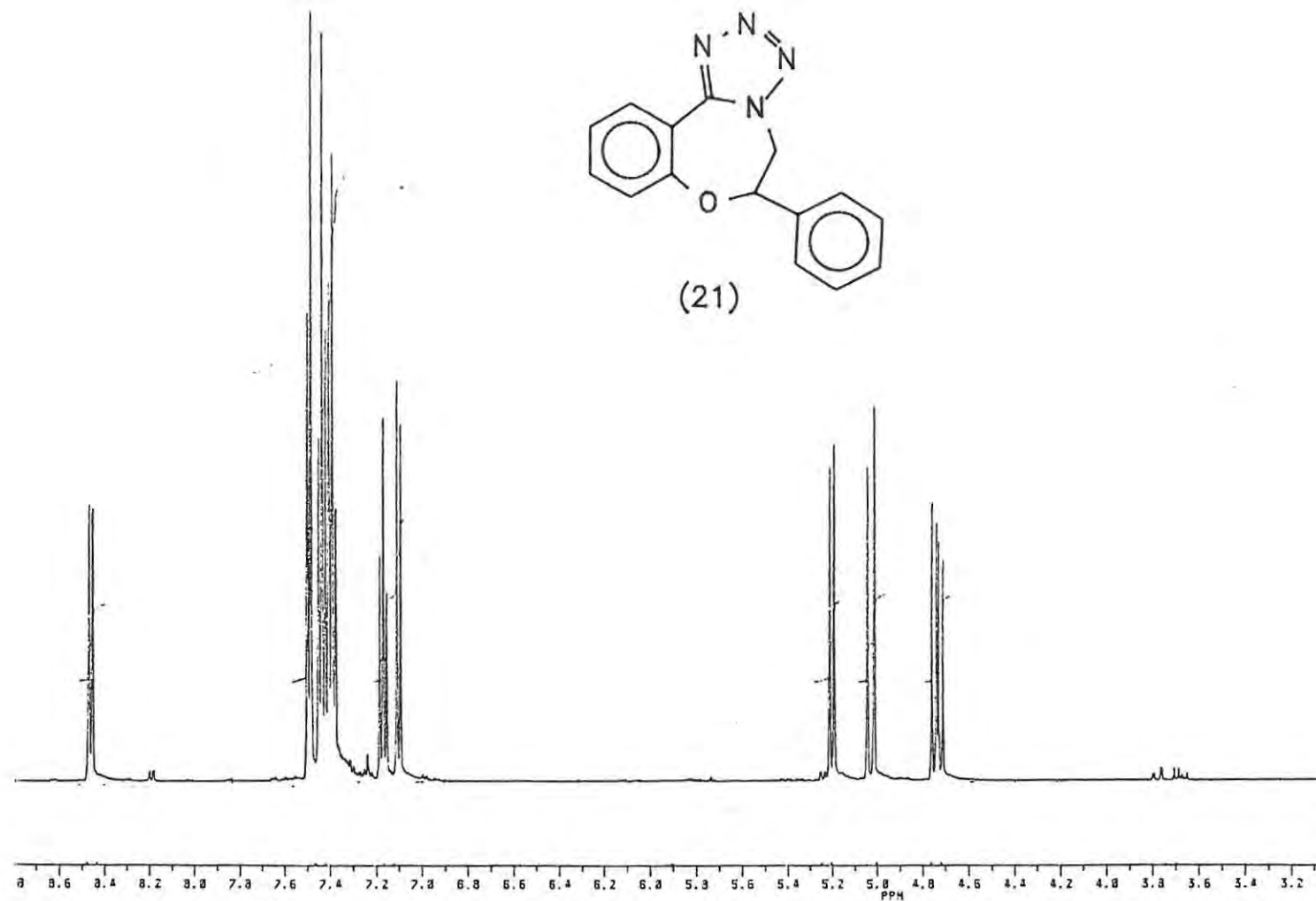
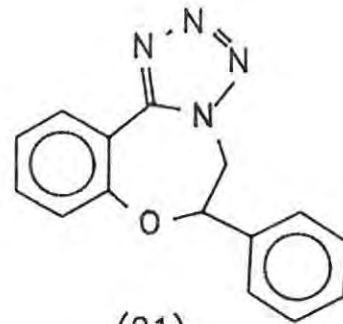

Spectrum 5: ¹H n.m.r. spectrum of
2,3-dihydro-2-phenyl-tetrazolo[1,5-d]-1,4-benzoxazepine (21)

Prod. 0.1 / 211

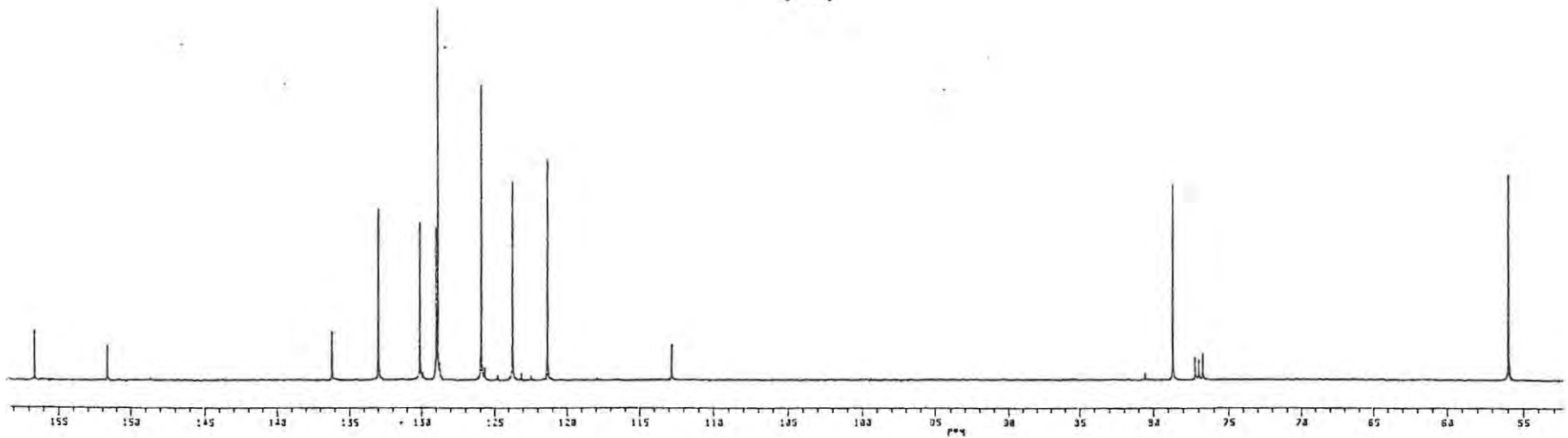
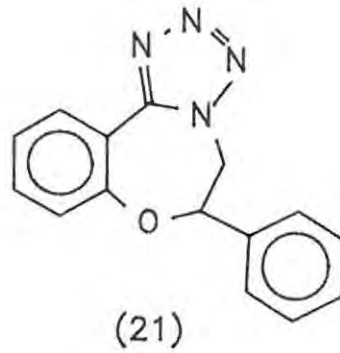

Spectrum 6: ^{13}C proton noise decoupled n.m.r. spectrum of
2,3-dihydro-2-phenyl-tetrazolo[1,5-d]-1,4-benzoxazepine (21)

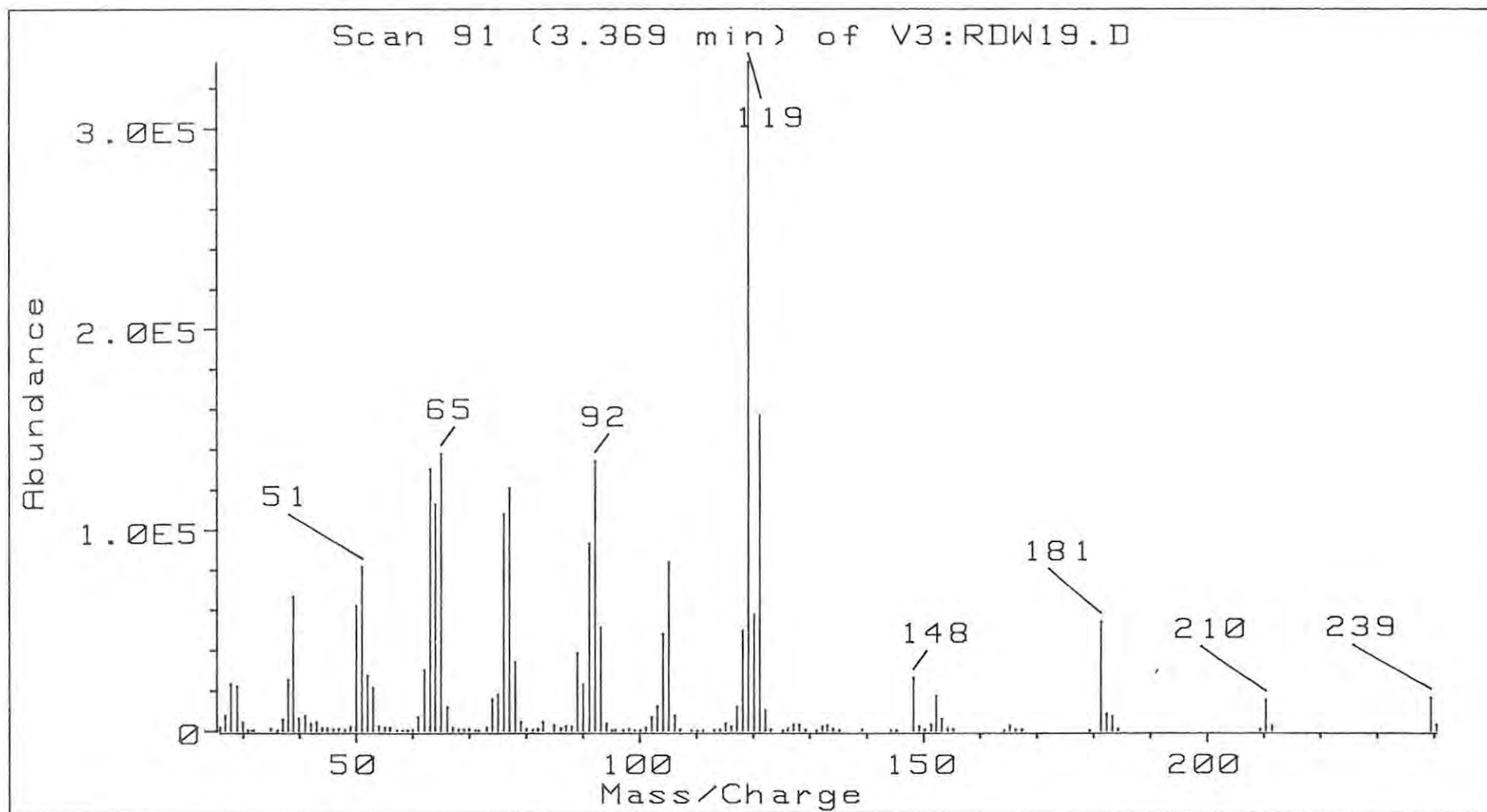

Spectrum 7: Low resolution mass spectrum of
2,3-dihydro-2-phenyl-1,4-benzoxazepin-5(4H)-one [(18), R = Ph]

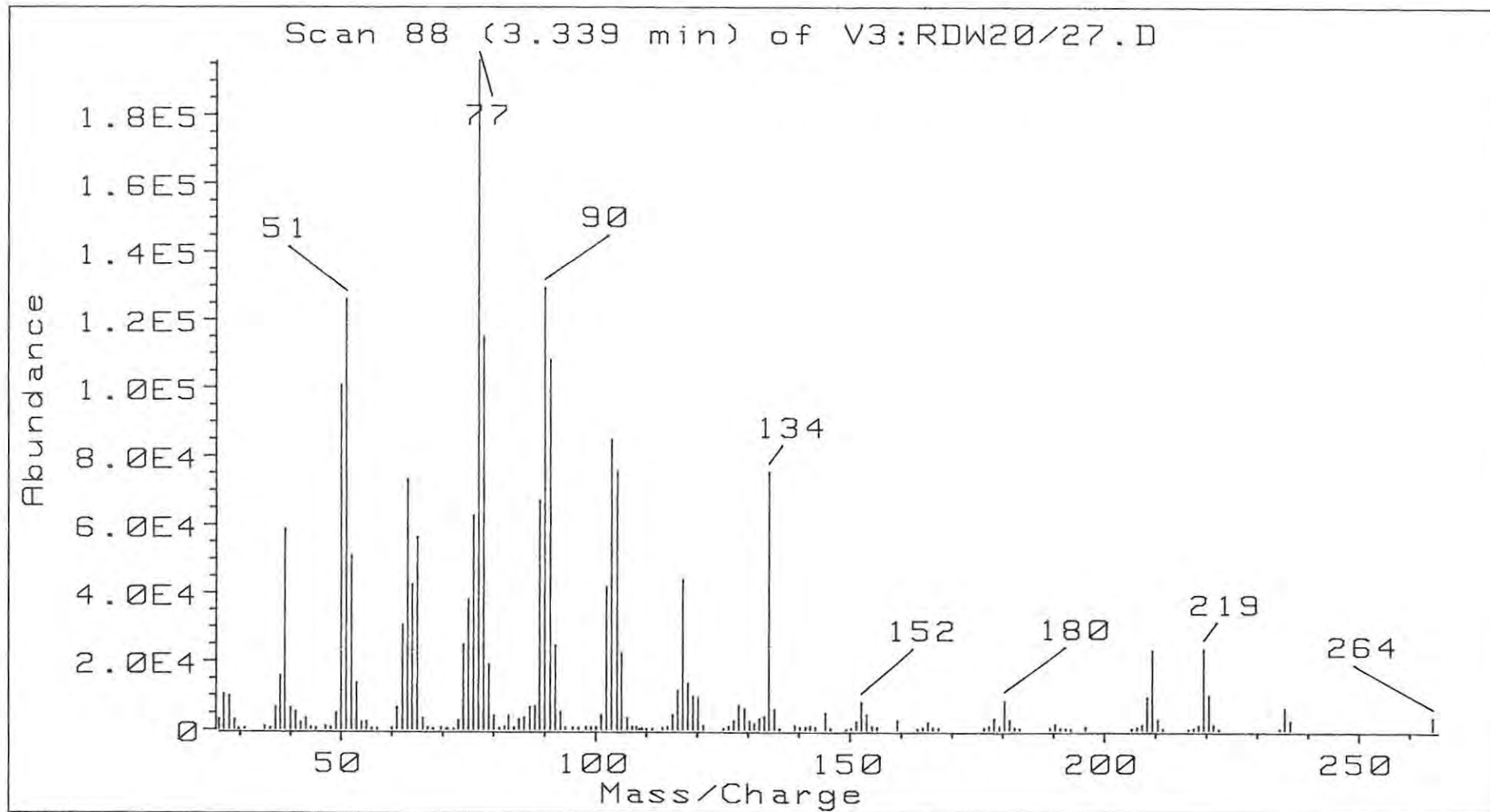

Spectrum 8: Low resolution mass spectrum of
2,3-dihydro-2-phenyl-tetrazolo[1,5-d]-1,4-benzoxazepine (21)

APPENDIX 3: X-ray crystallographic dataData collection and analysis

Good crystals of 2,3-dihydro-4-(hydroxyimino)-2-phenyl-4H-benzopyran were obtained from hot n-propanol and preliminary photography was carried out on a Stoe Damstadt reciprocal lattice explorer. An oscillation photograph about the axis defined by b^* showed a plane of symmetry, suggesting monoclinic or higher symmetry. The angle between a^* and c^* , as measured on a de Jong Bouman photograph of the reciprocal lattice plane $h0l$, was found to be 102.7° , confirming that the crystal must be monoclinic. De Jong Bouman and Buerger photographs afforded the general conditions for a reflection, hkl , to have a measurable intensity, which are:— 1.) for planes $h0l$, $h + l = 2n$; and 2.) for planes $0k0$, $k = 2n$. From the data contained in these photographs, the volume of the unit cell could be calculated and the unit cell was found to contain four molecules.

The above information suggested that the space group for these crystals is $P2_1/n$.

Crystallographic diffraction data were measured on an Enraf Nonius CAD 4 diffractometer using Mo $K\alpha$ x-radiation ($\lambda = 0.7107\text{\AA}$) and the exposure time were seventeen hours. The dimensions of the crystal used for the data collection were $0.35 \times 0.25 \times 0.45\text{mm}$.

Structure refinement

The SHELX ⁸⁹ program was used to refine the crystallographic diffraction data and solve the crystal structure and Pluto 78 was used to obtain plots of the molecular structure (Figure 3b) and packing diagram (Figure 3c). The crystal data are recorded in Table 1, fractional coordinates and equivalent isotropic temperature factors for non hydrogen atoms are recorded in Table 2, selected bond lengths and angles are contained in Table 3, anisotropic temperature factors are contained in Table 4, and fractional coordinates for hydrogen atoms are contained in Table 5. Observed and calculated structure factors are available from the Department of Chemistry, Rhodes University, Grahamstown.

Table 1. Crystal data for
2,3-dihydro-4-(hydroxyimino)-2-phenyl-4H-benzopyran.

Formula	$C_{15}H_{13}O_2N$
Molecular mass	239
Space group	$P2_1/n$
a (Å)	15.061
b (Å)	5.160
c (Å)	16.119
$\alpha = \gamma$	90°
β	102.68°
V (Å ³)	1221.80
Z	4
$\mu(\text{cm}^{-1})$	0.8
Number of reflections ($10^\circ < \theta < 12^\circ$)	2490
R (unit weights)	0.0831

Table 2. Fractional Coordinates ($\times 10^4$) and Equivalent Isotropic Temperature Factors (\AA^2 , $\times 10^4$) for Flavanone Oxime ($\text{C}_{15}\text{H}_{13}\text{O}_2\text{N}$).

	x/a	y/b	z/c	$\underline{U}_{\text{eq}}$
O(1)	1575(4)	3750(16)	10022(4)	77(2)
N(1)	4226(6)	1594(21)	10174(5)	87(3)
C(1)	2060(10)	2929(39)	10790(10)	119(5)
C(2)	2897(6)	1339(21)	10803(6)	64(3)
C(3)	3434(7)	2462(24)	10195(6)	68(3)
C(4)	2991(7)	4372(20)	9578(6)	61(3)
C(5)	3468(8)	5748(22)	9060(7)	82(4)
C(6)	3016(10)	7477(24)	8471(7)	92(4)
C(7)	2093(9)	7930(24)	8384(7)	86(4)
C(8)	1638(8)	6624(22)	8912(6)	76(3)
C(9)	2077(8)	4916(20)	9517(6)	61(3)
C(11)	903(9)	-315(31)	10959(7)	91(4)
C(12)	345(9)	-1646(31)	11406(11)	118(5)
C(13)	355(8)	-770(34)	12231(10)	107(5)
C(14)	885(10)	1218(32)	12554(8)	106(5)
C(15)	1451(8)	2485(26)	12090(8)	91(4)
C(10)	1427(7)	1634(24)	11277(7)	70(3)
O(2)	4532(5)	-337(16)	10785(4)	96(3)

$$\underline{U}_{\text{eq}} = \frac{1}{3} \sum_i \sum_j \underline{U}_{ij} \mathbf{a}_i^* \mathbf{a}_j^* (\mathbf{a}_i \cdot \mathbf{a}_j)$$

Table 4. Anisotropic Temperature Factors (\AA^2 , $\times 10^3$) for
Flavanone Oxime ($\text{C}_{15}\text{H}_{13}\text{O}_2\text{N}$)

	U(11)	U(22)	U(33)	U(23)	U(13)	U(12)
O(1)	65(5)	106(7)	52(4)	23(5)	-1(4)	2(5)
N(1)	88(7)	103(9)	80(6)	27(7)	37(6)	38(7)
C(1)	108(10)	164(16)	105(9)	71(12)	70(9)	30(12)
C(2)	54(6)	71(8)	70(7)	5(7)	19(6)	5(6)
C(3)	75(7)	84(9)	43(6)	4(6)	10(6)	7(7)
C(4)	75(8)	59(8)	53(6)	-3(6)	20(6)	16(6)
C(5)	93(9)	68(9)	97(9)	5(7)	48(7)	16(7)
C(6)	133(12)	69(9)	82(9)	22(8)	43(9)	16(9)
C(7)	130(11)	66(9)	59(7)	21(6)	12(8)	8(9)
C(8)	86(8)	68(9)	68(7)	10(7)	4(6)	(7)
C(9)	82(8)	43(6)	55(6)	-6(6)	8(6)	12(6)
C(11)	74(8)	120(12)	72(8)	-30(8)	0(7)	9(9)
C(12)	78(9)	106(13)	153(14)	12(13)	-14(10)	-33(9)
C(13)	65(9)	140(16)	116(12)	59(12)	18(9)	-7(9)
C(14)	100(11)	143(15)	80(9)	-9(11)	32(8)	0(11)
C(15)	94(9)	92(10)	94(10)	-23(8)	32(8)	-11(8)
C(10)	68(7)	73(9)	68(7)	14(8)	11(6)	7(7)
O(2)	109(6)	104(7)	83(5)	41(5)	41(5)	42(6)

Table 3. Selected Bond Lengths (Å) and Angles (°) for
Flavanone Oxime (C₁₅H₁₃O₂N)

O(1)—C(1)	1.361(13)	O(1)—C(9)	1.367(11)
N(1)—C(3)	1.281(11)	N(1)—O(2)	1.405(10)
C(1)—C(2)	1.500(14)	C(1)—C(10)	1.517(14)
C(2)—C(3)	1.516(12)	C(3)—C(4)	1.454(13)
C(4)—C(5)	1.407(13)	C(4)—C(9)	1.387(12)
C(5)—C(6)	1.370(14)	C(6)—C(7)	1.387(14)
C(7)—C(8)	1.379(14)	C(8)—C(9)	1.372(13)
C(11)—C(12)	1.40(2)	C(11)—C(10)	1.311(15)
C(12)—C(13)	1.40(2)	C(13)—C(14)	1.33(2)
C(14)—C(15)	1.41(2)	C(15)—C(10)	1.376(14)
C(1)—O(1)—C(9)	114.9(8)	C(3)—N(1)—O(2)	113.2(9)
O(1)—C(1)—C(2)	117.7(11)	O(1)—C(1)—C(10)	109.5(12)
C(2)—C(1)—C(10)	112.0(12)	C(1)—C(2)—C(3)	110.3(9)
N(1)—C(3)—C(2)	121.0(10)	N(1)—C(3)—C(4)	120.5(10)
C(2)—C(3)—C(4)	118.2(9)	C(3)—C(4)—C(5)	122.1(10)
C(3)—C(4)—C(9)	119.0(10)	C(5)—C(4)—C(9)	118.9(10)
C(4)—C(5)—C(6)	119.9(11)	C(5)—C(6)—C(7)	121.0(12)
C(6)—C(7)—C(8)	118.6(11)	C(7)—C(8)—C(9)	121.7(12)
O(1)—C(9)—C(4)	122.7(9)	O(1)—C(9)—C(8)	117.5(10)
C(4)—C(9)—C(8)	119.8(11)	C(12)—C(11)—C(10)	123.5(12)
C(11)—C(12)—C(13)	116.6(13)	C(12)—C(13)—C(14)	119.9(14)
C(13)—C(14)—C(15)	122.0(13)	C(14)—C(15)—C(10)	117.7(12)
C(1)—C(10)—C(11)	121.9(14)	C(1)—C(10)—C(15)	117.7(14)
C(11)—C(10)—C(15)	120.3(12)		

Table 5. Fractional Coordinates ($\times 10^4$) for Hydrogen Atoms
of Flavanone Oxime ($C_{15}H_{13}O_2N$)

	x/a	y/b	z/c	U
H(1)	2353(10)	4679(39)	11103(10)	301(136)
H(2A)	3319(6)	1338(21)	11439(6)	126(21)
H(2B)	2700(6)	-624(21)	10616(6)	126(21)
H(5)	4189(8)	5428(22)	9123(7)	118(29)
H(6)	3386(10)	8504(24)	8070(7)	118(29)
H(7)	1736(9)	9277(24)	7914(7)	126(21)
H(8)	918(8)	6956(22)	8847(6)	126(21)
H(11)	901(9)	-925(31)	10317(7)	257(39)
H(12)	-70(9)	3265(31)	11129(11)	257(39)
H(13)	-67(8)	-1704(34)	12605(10)	257(39)
H(14)	882(10)	1873(32)	13189(8)	257(39)
H(15)	1885(8)	4072(26)	12364(8)	257(39)