

# Gullstrand's Optical Schematic System of the Eye – Modified by Vojniković & Tamajo

Božo Vojniković and Ettore Tamajo

Velika Gorica University of Applied Sciences, Velika Gorica, Croatia

## ABSTRACT

According to early examination (Vojniković, 1978) estimated, that the index of refraction for aqueous and vitreous is not the sum (1.33 or 1.66), than is for aqueous  $n = 1.334$ , and for vitreous  $N = 1.336$ . This measurements are made with Abbe's refractometer, by temperature of 33 °C for aqueous, and 36 °C for vitreous, as it's in human eye. In the principle of these results, the authors calculated the new values of cardinal points for the eye, and compared with Gullstrand's optical schematic eye. So, the refractive power for the eye  $F = 59.98 D$ , first focal length  $f_1 = -16.67 mm$  and second focal length  $f_2 = +22.27 mm$

**Key words:** optical schematic eye, modified the position of the cardinal points

## Introduction

Kepler was the first to introduce in 1611. the term of »Dioptrice«, and later, in 1704. Newton first described the dioptric system of the eye<sup>1</sup>. Thomas Young 1801. Estimated the astigmatism of the eye and two meridians, major and minor, and first measurements the several optical constants of the eye. The progress of the study of optical eye system was little. Not earlier than 1841. Gauss introduce the six cardinal points ( $F_1, F_2, P_1, P_2, N_1, N_2$ ) of the optical system of the eye, published in »Dioptrische Untersuchungen«, and 1853. Gauss calculated the first theoretical optical schematic eye, »Dioptrik des Auges«.<sup>1</sup> This work of Gauss stimulated a further intensive study of the eye optics, and then Helmholtz was modified and adopted the Gaussian schematic eye, so that all later works are based on this Helmholtz publication 1856. »Physiologischen Optik«. Only 1856. And than continuity, the next pioneers: Donders 1864., Tscherning 1898., Javal, and than appear Gullstrand 1911. with the work: »Einführung in die Methoden d. Dioptrik d. Auges d. Menschen«. For this work Gullstrand received a Nobel Prize in 1911.<sup>1</sup> As yet today, the Gullstrand's schematic eye exist, sometimes with modification because the different values of optical and anatomical of the eye(index of refraction of optical eye media, radius curvature of cornea and lens, axial length of eye globe). Our study and

reason for modification of standard Gullstrand schematic eye, is our work on measured the index of refraction the aqueous and vitreous.

## Materials and Methods

Our earlier study<sup>2,3</sup> establishes the truth of different values of index of refraction for aqueous and vitreous. Measurements of index of refraction »n« of aqueous and vitreous were carried out respecting strictly determined conditions of examination. The first, very important, is considered the fact that these measurements were performed at a definite temperature of 33 °C for aqueous and 36 °C for vitreous (33 °C as the usually temperature of aqueous, and 36 °C for vitreous), and by means of monochromatic sodium yellow light line  $N = 589.3 mu$ . These measurements are made with Abbe's refractometer.

In this examination was estimated the means of index of refraction for *aqueous* = 1.334, and for *vitreous* = 1.336. In Gullstrand schematic eye the index of refraction for both of aqueous and vitreous is 1.336. In our calculation for new optical schematic eye<sup>4-6</sup>, the optical and anatomical means of the eye was identity, except the means of index of refraction of vitreous, »n« is 1.334

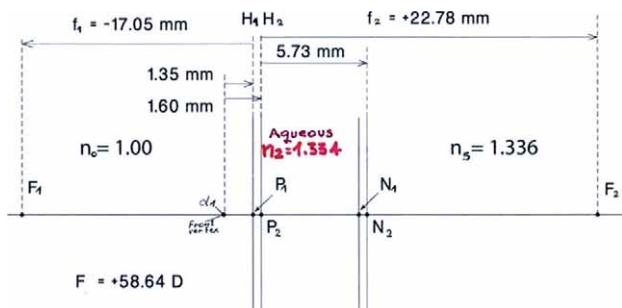

Fig. 1. Shows the Gullstrand's means of optical schematic of the eye. The difference is in value of index of refraction for aqueous,  $N=1.334$ .

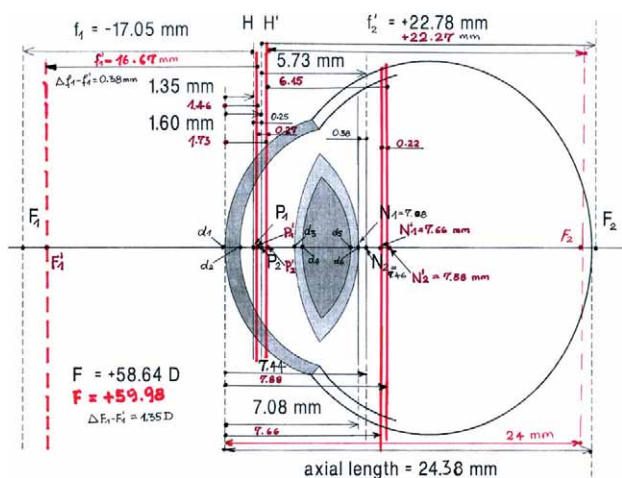

Fig. 2. Represent the schematic optical values of the eye, for Gullstrand's and for modified schemataic eye in our examination (red marked).

Mean refractive indices:

air	.....	$n_0$	.....	1.000
cornean	.....	1	.....	1.376
aqueous	.....	2	.....	1.334
crystalline core- lens	.....	$n_3$	.....	1.386
crystalline nucleus lens	.....	$n_4$	.....	1.406
vitreous	.....	$n_5$	.....	1.336

Radii of curvature:

- Cornea anterior surface  
.....  $r_1 = +7.70$  mm.. position: 0.00 mm -  $d_1$
- Cornea posterior surface  
.....  $r_2 = +6.80$  mm.. position: +0.50 mm -  $d_2$
- Lens anterior surface  
.....  $r_3 = +10.00$  mm.. position: +3.60 mm -  $d_3$

- Lens nucleus anterior surfacer  
.....  $r_4 = +7.91$  mm.. position: +4.15 mm -  $d_4$
- Lens nucleus posterior surfacer  
.....  $r_5 = -5.76$  mm.. position: +6.57 mm -  $d_5$
- Lens posterior surfacer  
.....  $r_6 = -6.00$  mm.. position: +7.20 mm -  $d_6$

Results

Calculation the power of anterior surface of cornea:

$$F_{c1} = (n_1 - n_0)/r_1 = (1.376 - 1.00)/0.0077 = +48.8312 \text{ D}$$

Calculation the power of posterior surface of cornea

$$F_{c2} = (n_2 - n_1)/r_2 = (1.334 - 1.376)/0.0068 = -6.1765 \text{ D}$$

Equivalent power of cornea:

$$F_c = F_{c1} + F_{c2} - (r_1 - r_2)/n_1 * F_{c1} * F_{c2} = 48.8312 - 6.1765 - (0.0077 - 0.0068)/1.376 * 48.8312 * (-6.1765) = +42.8520 \text{ D}$$

Reduced cornea thickness:

$$c = \frac{d_2 - d_1}{n_1} = \frac{0.005 - 0.0}{1.376} = 0.000363372 \text{ m} = 0.3634 \text{ mm}$$

Final power of cornea:

$$F = F_{c1} + F_{c2} - c * F_{c1} * F_{c2}$$

$$F = +48.8312 - 6.1765 - 0.000363372 * 48.8312 * (-6.1765) =$$

$$F = +42.7643 \text{ D}$$

Focal length of the cornea:

$$\frac{1}{f_1} = \frac{(n_1 - n_2)}{n_0 * r_2} - \frac{(n_1 - n_0)}{n_0 * r_1} - \frac{(n_1 - n_0) * (n_1 - n_2) * (d_2 - d_1)}{n_1 * r_1 * r_2} =$$

$$\frac{1}{f_1} = -6.17647 - 48.83117 + 0.10959 = -54.89805 \text{ D}$$

$$f_1 = -0.018215584 \text{ m}$$

$$f_2 = -\frac{n_2}{n_0} * f_1 = +0.0243 \text{ m}$$

Position of the 1. cardinal plane of the cornea:

$$A_1 H_c = -\frac{(n_1 - n_2)}{n_1 * r_2} * f_1 * (d_2 - d_1)$$

$$A_1 H_c = -\frac{(1.376 - 1.334)}{1.376 * (-0.006)} * (-0.018216) * (0.0005 - 0.0) = 0.000040883 \text{ m} = 0.0409 \text{ mm}$$

Position of the 2. cardinal plane of the cornea:

$$A_2 H_c = -\frac{(n_1 - n_0)}{n_1 * r_1} * f_2 * (d_2 - d_1)$$

$$A_2 H_c = -\frac{(1.376 - 1.0)}{1.376 * 0.0077} * (0.0243) * (0.0005 - 0.0) =$$

$$-0.000431176 \text{ m} = -0.4312 \text{ mm}$$

Position of the nodal points of the cornea:

$$N_1 = \left[ 1 - \frac{n_2}{n_0} + \frac{(n_1 - n_2)}{n_1 * r_2} * (d_2 - d_1) \right] * f_1 =$$

$$= \left[ 1 - \frac{1.334}{1.0} + \frac{(1.376 - 1.334)}{1.376 * (-0.0068)} * (0.0005 - 0.0) \right] * (-0.01822) =$$

$$= 0.006126372 \text{ m} = 6.13 \text{ mm}$$

$$N_2 = \left[ 1 - \frac{n_0}{n_2} + \frac{(n_1 - n_0)}{n_1 * r_1} * (d_2 - d_1) \right] * f_2 =$$

$$= \left[ 1 - \frac{1.0}{1.334} + \frac{(1.376 - 1.0)}{1.376 * (0.0077)} * (0.0005 - 0.0) \right] * (0.0243)$$

$$= 0.005652931 \text{ m} = 5.65 \text{ mm}$$

Refractive power of the anterior cortex lens:

$$F_3 = \frac{(n_3 - n_2)}{r_3} = \frac{(1.386 - 1.334)}{0.01} = +5.2 \text{ D}$$

Refractive power of anterior nucleus lens :

$$F_4 = \frac{(n_4 - n_3)}{r_4} = \frac{1.406 - 1.386}{0.00791} = +2.528445 \text{ D}$$

Reduced the latitude of anterior lens cortex:

$$C = \frac{(d_4 - d_3)}{n_3} = \frac{(0.00415 - 0.0036)}{1.386} =$$

$$0.000396825 \text{ m} = 0.3968 \text{ mm}$$

Final refractive power of anterior lens cortex:

$$F = F_3 + F_4 - C * F_3 * F_4 =$$

$$+5.2 + 2.52845 - 0.0003968 * 5.2 * 2.52845 = +7.72323 \text{ D}$$

Focal length of anterior cortex lens

$$\frac{1}{f_3} = \frac{(n_3 - n_4)}{n_2 * r_6} - \frac{(n_3 - n_2)}{n_2 * r_3} - \frac{(n_3 - n_2)}{n_2} * \frac{(n_3 - n_4)}{n_3} * \frac{(d_4 - d_3)}{r_3 * r_6} =$$

$$-6.40195778 \text{ D}$$

$$f_3 = -0.156202217 \text{ m}$$

$$f_4 = -\frac{n_4}{n_2} * f_3 = -\frac{1.406}{1.334} * (-0.15620) = 0.164630584 \text{ m}$$

Position of the 1. principal plane of lens cortex:

$$A_3 H_{ac} = \frac{(n_3 - n_4)}{n_3 * r_6} * f_3 * (d_4 - d_3) =$$

$$0.000217768 \text{ m} = 0.218 \text{ mm}$$

Position of the 2. principal plane of lens cortex:

$$A_4 H_{ac} = -\frac{(n_3 - n_2)}{n_3 * r_3} * f_4 * (d_6 - d_5) =$$

$$-0.000389132 = -0.389 \text{ mm}$$

Position of nodal points anterior lens cortex:

$$N_3 = \left[ 1 - \frac{n_4}{n_2} + \frac{(n_3 - n_4)}{n_3 * r_6} * (d_4 - d_3) \right] * f_3 =$$

$$= \left[ 1 - \frac{1.406}{1.334} + \frac{(1.386 - 1.406)}{1.386 * (0.006)} * (0.00415 - 0.0036) \right] * (-0.1562022)$$

$$= 0.008224085 \text{ m} = 8.22 \text{ mm}$$

$$N_4 = \left[ 1 - \frac{n_2}{n_4} + \frac{(n_3 - n_2)}{n_3 * r_3} * (d_6 - d_5) \right] * f_4 =$$

$$= \left[ 1 - \frac{1.334}{1.406} + \frac{(1.386 - 1.334)}{1.386 * 0.01} * (0.0072 - 0.00657) \right] * (0.164632921)$$

$$= 0.008041719 \text{ m} = 8.04 \text{ mm}$$

Refraction power of posterior lens nucleus:

$$F_5 = \frac{(n_3 - n_4)}{r_5} = \frac{(1.386 - 1.406)}{-0.00576} = +3.4722 \text{ D}$$

Refraction power of posterior lens cortex:

$$F_6 = \frac{(n_5 - n_3)}{r_6} = \frac{(1.336 - 1.386)}{-0.006} = +8.3333 \text{ D}$$

Reduced the latitude of posterior lens cortex:

$$C = \frac{(d_6 - d_5)}{n_3} = \frac{(0.0072 - 0.00657)}{1.386} = 0.000454545 \text{ m} = 0.455 \text{ mm}$$

Refraction power of posterior lens cortex:

$$F = F_5 + F_6 - C * F_5 * F_6 =$$

$$+3.4722 + 8.3333 - 0.0004545 * 3.4722 * 8.3333 = +11.792348 \text{ D}$$

Focal lengths of posterior lens cortex:

$$\frac{1}{f_5} = \frac{(n_3 - n_5)}{n_4 * r_3} - \frac{(n_3 - n_4)}{n_4 * r_6} - \frac{(n_3 - n_4)}{n_4} * \frac{(n_3 - n_5)}{n_3} * \frac{(d_6 - d_5)}{r_3 * r_6} =$$

$$1.18000776 \text{ D}$$

$$f_6 = -\frac{n_5}{n_4} * f_5 = -\frac{1.336}{1.406} * (0.847452) = -0.805260273 \text{ m}$$

Position of 1. principal plane of posterior lens cortex:

$$A_5 H_{pc} = \frac{n_3 - n_5}{n_3} * f_5 * (d_6 - d_5) = -0.00321 \text{ m} = -3.21 \text{ mm}$$

Position of 2. principal plane of posterior lens cortex:

$$A_6 H_{pc} = -\frac{(n_3 - n_4)}{n_3} * f_6 * (d_6 - d_5) = -0.000732 \text{ m} = -0.732 \text{ mm}$$

Position of nodal points of posterior lens cortex

$$N_5 = \left[ 1 - \frac{n_5}{n_4} + \frac{(n_3 - n_5)}{n_3} * \frac{(d_6 - d_5)}{r_6} \right] * f_5 =$$

$$= \left[ 1 - \frac{1.336}{1.406} + \frac{(1.386 - 1.336)}{1.386} * (0.0072 - 0.00657) \right] * (0.847452054)$$

$$= 0.038981735 \text{ m} = 38.98 \text{ mm}$$

$$N_6 = \left[ 1 - \frac{n_5}{n_4} + \frac{(n_3 - n_4)}{n_3} * \frac{(d_6 - d_5)}{r_3} \right] * f_6 =$$

$$= \left[ 1 - \frac{1.336}{1.406} + \frac{(1.386 - 1.406)}{1.386} * 0.01 \right] * (-0.80526027)$$

$$= -0.040823249 \text{ m} = -40.82 \text{ mm}$$

Equivalent power of lens (cortex + nucleus):

$$F = F_{\text{anterior-cortex}} + F_{\text{posterior-cortex}} -$$

$$C * F_{\text{anterior-cortex}} * F_{\text{posterior-cortex}}$$

$$F = 7.72323 + 11.792348 - 0.000838642 * 7.723 * 11.792 =$$

$$+ 19.43919867 \text{ D}$$

Reduced the latitude of lens:

$$C = \frac{[A_4 H_{ac} + (d_5 - d_4) + A_5 H_{pc}]}{n_4} = 0.000838642 \text{ m}$$

Refracting power of complete system of the eye:

$$F = F_{\text{corneas}} + F_{\text{whole lens}} - C * F_{\text{corneas}} * F_{\text{whole lens}}$$

$$F = 42.7643 + 19.43919867 - 0.002667784 * 42.764 * 19.439 =$$

$$+ 59.9857599 \text{ D}$$

$$F = +59.98576 \text{ D}$$

Reduced the latitude of the eye:

$$C = \frac{[A_2 H_c + d_6 + A_5 H_{pc}]}{n_2} =$$

$$C = \frac{[-0.0004312 + 7.20 \cdot 10^{-3} - 0.00321]}{1.334} = 2.667783 \text{ mm}$$

Position of the 1. Principal plane of thy eye:

$$A_1 H_{\text{eye}} = \frac{n_0 \cdot c \cdot F_3}{F_{\text{eye}}} = 0.00146 \text{ m}$$

Position of the 2. principal plane of the eye:

$$A_2 H_{\text{eye}} = \frac{n_5 \cdot c \cdot F_{\text{cornea}}}{F_{\text{eye}}} = 0.00172900 \text{ m}$$

1. focal length of the eye:

$$f_1 = \frac{n_0}{F_{\text{eye}}} = \frac{1.0}{59.98576} = -16.670623 \text{ mm}$$

2. focal length of the eye:

$$f_2 = -\frac{n_5}{F_{\text{eye}}} = -\frac{1.336}{59.98576} = +22.271952 \text{ mm}$$

Position of nodal points of the eye:

$$N_1 = \left[ 1 - \frac{n_5}{n_4} + \frac{(n_3 - n_5)}{n_3} \cdot \frac{(d_6 - d_5)}{r_6} \right] \cdot f_5 = 7.66 \text{ mm}$$

$$N_2 = \left[ 1 - \frac{n_5}{n_4} + \frac{(n_3 - n_4)}{n_3} \cdot \frac{(d_6 - d_5)}{r_3} \right] \cdot f_6 = 7.88 \text{ mm}$$

Position of the retinal fovea = 24.0 mm

## Discussion and Conclusion

Difference between Gullstrand calculation in optical schematic eye and our calculation is the mean of refractive index for aqueous. Historically, all included authors gives the same means of refractive indices for aqueous and vitreous: 1.333 and 1.336 (1, Essential part in this examination were carried out respecting strictly determined conditions of testing the refractive index for aqueous and vitreous of human eye<sup>2,3</sup>. As particularly important is considered the fact that these measurements were performed at a definite temperature (33 °C for aqueous and 36 °C for vitreous, as in human eye) and by means of monochromatic sodium yellow light line: N = 589, 3 mu. Sometimes is very difficulty discussion about optical calculation for the eye, because the means of optical and anatomical elements of the eye are not the same. Consequently, the different of refractive index of aqueous of 1.334 and that is not the same as vitreous, 1.336, we can conclude:

1. The 1. principal plane  $H = 1.46 \text{ mm}$  (Gullstrand ( $G = 1.35 \text{ mm}$ ))
2. The 2. principal plane  $H' = 1.73 \text{ mm}$  ( $G = 1.60 \text{ mm}$ )
3. The 1. nodal point  $N_1 = 7.66 \text{ mm}$  ( $G = 7.08 \text{ mm}$ )
4. The 2. nodal point  $N_1 = 7.88 \text{ mm}$  ( $G = 7.46 \text{ mm}$ )
5. The 1. focal length  $f_1 = -16.67 \text{ mm}$  ( $G = -17.05 \text{ mm}$ )
6. The 2. focal length  $f_2 = +22.27 \text{ mm}$  ( $G = 22.78 \text{ mm}$ )
7. Refracting power of complete system of the eye  $F = 59.985 \text{ D}$  ( $G_1 = 58.640 \text{ D}$ ,  $G_2 = 60.48 \text{ D}$ )

## REFERENCES

1. DUKE-ELDER S, System of Ophthalmology, Vol. V, Ophthalmic Optics and Refraction, Henry Kimpton, London (1970). — 2. VOJNIKOVIC B, DOOH, Zagreb, 2 (1978). — 3. VOJNIKOVIC B, LUTTENBERGER I, Jug. oftalm. arhiv, 3–4 (1979). — 4. STONER E D, PERKINS P, Optical formulas tutorial, Butterworth-Heinemann, Boston (1997). — 5. ATCHINSON D A, SMITH G, Optics of the Human Eye (Butterworth-Heinemann, Oxford 2000.). 6 – PEDROTTI L S, PEDROTTI S L, Optics and Vision. ISBN: 0132422239.

*B. Vojniković*

*Velika Gorica University of Applied of Sciences, Zagrebačka cesta 5, 10410 Velika Gorica, Croatia  
e-mail: decv@decv.com*

## GULLSTRAND-ovo OPTIČKI SHEMATSKO OKO – MODIFIKACIJA PO VOJNIKOVIC I TAMAJO

### SAŽETAK

Na osnovu ranijih mjerenja indeksa loma »n« (Vojniković, 1970) optičkih medija oka, sobne vodice i staklastog tijela, pod određenim uvjetima: kod temperature od 33 °C za sobnu vodicu = 1.334 i 36 °C za staklasto tijelo = 1.336, autori su pristupili izračunu optičkih vrijednosti oka. U literaturi se uvijek susreću identične vrijednosti indeksa loma za sobnu vodicu i staklasto tijelo (1.333 i 1.336). Izračun pokazuje određene razlike od prvog Gullstrandova izračuna, za kojeg mu je i dodijeljena Nobelova nagrada 1911. Tako npr. refrakcijska vrijednost čitavog oka iznosi 59, 98 D, prednja žarišna daljina  $f_1 = -16, 67\text{mm}$ , stražnja žarišna daljina  $f_2 = +22, 27\text{mm}$ . Promjene su također nastupile i u vrijednostima ostalih kardinalnih točaka:  $P_1, P_2$  i  $N_1, N_2$ . Zaključuje se kako bi ove vrijednosti trebalo koristiti u optičkom računu u refraktivnoj kirurgiji oka.