

D. LETIĆ, B. DAVIDOVIĆ, I. BERKOVIĆ, B. RADULOVIĆ, J. SAVIČIĆ

ISSN 0543-5846

METABK 52(1) 115-118 (2013)

UDC – UDK 621.9.002.5:621.833:658.23=111

PLANNING OF DESIGNING AND INSTALLATION OF MECHANICAL ELEMENTS AT THE GEAR SPEED REDUCER ON THE BASIS OF THE PARAMETER TECHNOLOGY

Received – Prispjelo: 2012-05-10

Accepted – Prihvaćeno: 2012-08-30

Preliminary Note – Prethodno priopćenje

The development and implementation of the computer methods at project managing in the part of the planning of designing and installation of mechanical elements with the fit (assembly block) of the gear speed reducer is significant and at present irreplaceable engineering task if it has been realized by the modern parameter technology. There are multifunction uses of this organized group of activities, beginning from the quick changeability of elements still in the phase of designing and constructing, thanks to the characteristics of their associativity, still to the wide basis of standard elements that are incorporated in the very program package. Meanwhile, these activities are not simple, so their realization has to be planned from the stand - point of time, resource and cost of realization. For the very designing and constructing was used AutoCAD Mechanical, and for the design managing Microsoft Project.

Key words: Mechanical elements, speed, reducer, CAD/CAE technologies, Project Management

INTRODUCTION

The computer methods and technologies of the type CAD/CAE have been given in recent years a fundamental new access to the process of projecting or designing and constructing [1, 2]. By computers applying will be multifunctionally shortened that process and, besides direct time saving, it enables substantially shortened way for the products development. In principle as well with constructing, beginning with the essential entities, still to the creating the complex 3D models, there take place large – scale calculations. With the computer geometry modelling a constructor – practician is not practically interested how is mathematically formed e.g. Bézier's curve or the union of many solids on the principle of Bool's mathematics, but only the results and effects of the application of the user oriented tools. Because there is necessary high interactivity user – computer, every creating and/or editing is adapted to the user not only concerning geometry, calculation or graphics as the result of the information processing and the likes. Though Mechanical Structure (Figure 1) in AutoCAD [3], the user will learn to work with the folders and components of the view on the drawing.

The same refers to the survey of the Bill of Materials (BOM) [4], restructuring geometry components, then how to insert components from the external file, changes in real time localization of the outer drawing components and the changes of the fixed form of the local components.

D. Letić, B. Davidović, I. Berković, B. Radulović, Technical Faculty "Mihajlo Pupin", Zrenjanin, J. Savičić, Faculty of Education, Sombor, University of Novi Sad

The Function of the Mechanical Structure

In this example is visually presented the machine structure necessary for forming the objects and folders that logically and structurally support the drawing.

Meanwhile, parallelly with the defining of the hierarchy structure of the elements in the fit, there has also to be defined the sequence of the construction performing, and later its realization in production, especially when there is team work at stake. This set of the designer's activities is backed by a program package as e.g. is MS Project [5], so that for the treated fit are given the elements of the ganttogram (Figure 2) or network diagram of these activities which can be described in details up to the level of small time units (e.g., minutes).

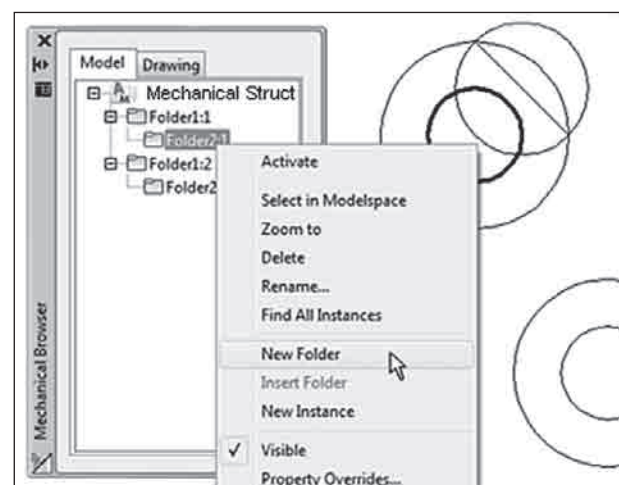

Figure 1 The duality of objects with the tree hierarchy of its forming

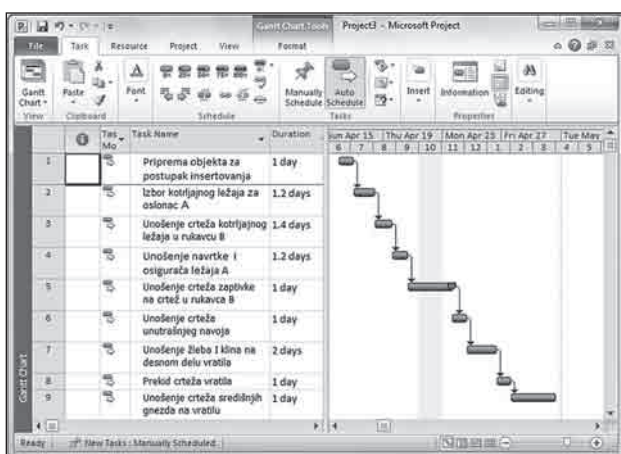

Figure 2 The ganttogram of the activities at the assembling of the toothed transmission gear

The function of the bearings and sealings at the reducing gear constructing

Bearings are the machine elements for the abutment of the shafts and axles. According to the more detailed definition [6] the bearings are the machine parts or engine details. Their assignment is to enable relative movement of the revolving parts together with the transmission of loading and ensuring of the accuracy of their location. One can differentiate carrier bearings for the radial force as well for the axial forces. The bearings ought to be lubricated in order to reduce frictions, heatings, vibrations and increasing of the degrees of efficiency and safety. The application of the roller bearers or antifriction bearings is considerably greater than the slide ones. They are distinguished by high degree of standardization and mass production in the specialized factories, lower producer's cost, relatively simple structural construction of the bedding with satisfying carrying capacity for lower and medium rotation frequency, simple lubrication and maintenance and the convenience of replacement. The suitability of installation is not always present. The rolling bearings are accident sensitive to the impact loads and they are substantially more expensive than the slide bearings.

The montage and dismantlement (depending on types) can be more complex than with the sliding bearings. They are classified as follows: ball bearings, cylindrical, conoid – cylindrical, or tapered roller bearings, barrel shaped bearings, needle bearings and similar ones. The calculation of the carrying capacity is developed as for static working state so for the dynamical one. The sealings prevent leaking of the lubricants and penetration of alien bodies, the entrance of impurities, dust, etc. into the bearing or in the working premises (e.g. with the reducedr or multiplicator) where it is positioned. Different solutions of these sealing joints have been applied. For the sealing of bearings up to the medium working speeds are sufficient the trapezoidal sealings. The sealing material is as well the artificial rubber resistant to the oil effects. Sealing packings have

been used for the reliable sealing at the less pressure of the sealing material on the sliding surfaces. Further in this paper was worked out the sequence of the installations of the radial rubber ring between the shaft and the ring sealing at the housing. The choice of the rolling bearings has been performed on the basis of the assigned working conditions, according to the working characteristics of some bearings. The designer at first commits himself to the certain type of the rolling bearing and then determinates the necessary dimensions according to the standard procedure. The selection of its value has been performed taking into consideration its static, dynamical carrying capacity respectively. In the case that the bearing size is known, as well the exploitation conditions in which it is, its lifespan can be checked. The choice can be performed in this way choosing the best solution from many available variants. This selection method practically is a simulation procedure as the part of the bearing calculation. In this way can be obtained e.g. these data:

Dynamic Radial Factor X:	0,56
Dynamic Axial Factor Y:	2,19
Static Load Rating Co:	32500 N
Dinamic Load Rating C:	47500 N
Adjusted Rating Life Lna:	394910 h
fo Factor	15,26.

The application of the method of the including standard elements for the gear

On the unfinished subassembly the *Elements of the gear according* to the Figure 3 add the drawings of the standard bearings, screws, wedge, sealing and similar:

- The preparation of the object for the application of the carrying in.

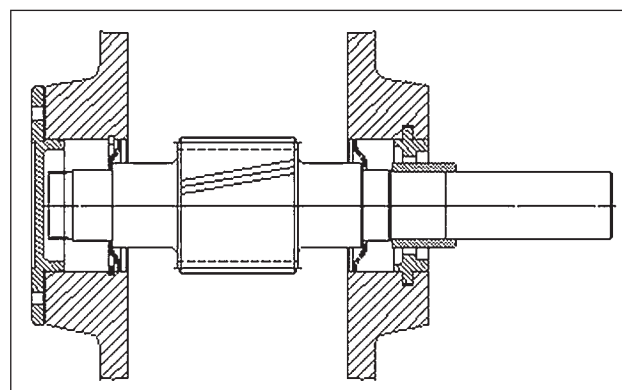

Figure 3 The gear shaft prepared for carrying in the bearing, securing, sealing and wedge

- The choice of the rolling bearing for the support A:
- From the obtainable family of these bearings chose the standard one, according to DIN 628 - 3: 2008.
- The verification of the load follows on the basis of the current dialogue DIN 628-3: 2008.
- Similar procedure can be done as well with the entering of the rolling bearing drawing for B journal

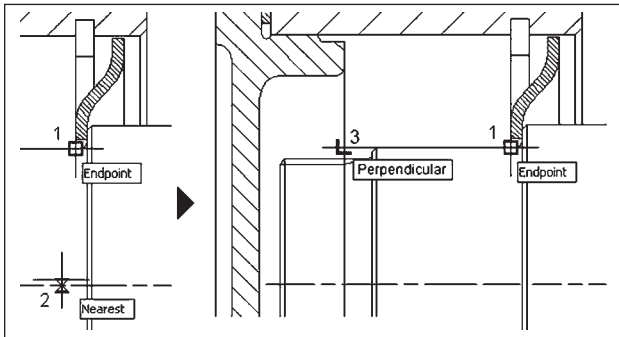

Figure 4 Two phases of the carrying in of the rolling bearings in the support A

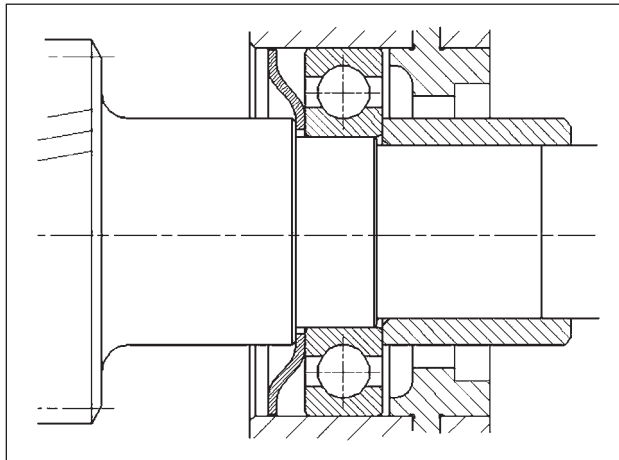

Figure 5 Two phases of the bringing in and verification of the rolling bearings in the B support

- Carrying in the nut and the locking of A bearing
- Bringing in the sealing object on the drawing of B pivot

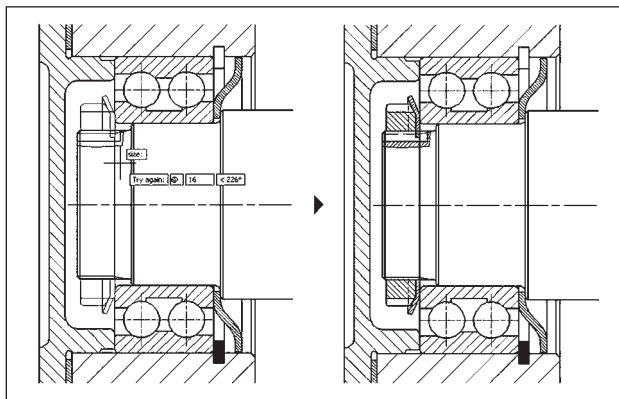

Figure 6 The finishing phase of the inserting of the nut and the nut circlip

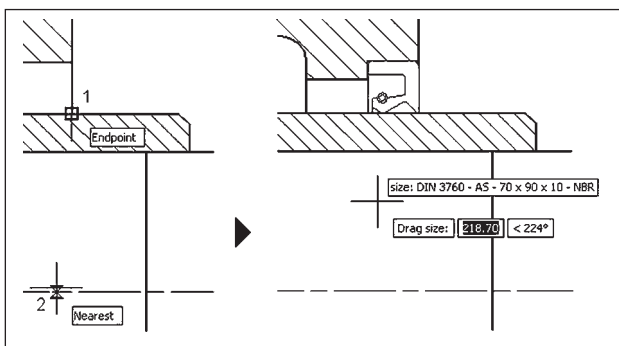

Figure 7 The phases of the sealing setting on the shaft collar

The inserting of the drawing for the inside screw thread

Select the symbol of the internal screw thread by the procedure from the menu: Content ▶ Holes ▶ Tapped Blind Holes... and so is being opened the dialogue Select a Tapped Blind Hole.

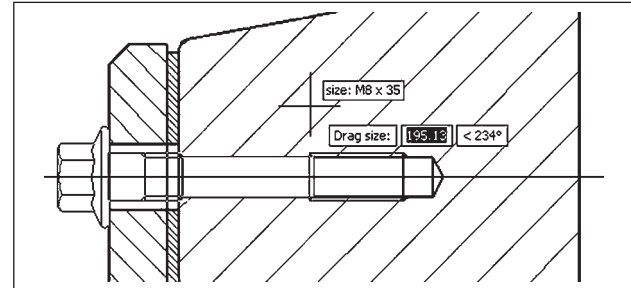

Figure 8 The phases of carrying in M8 x 35 mm screw

- The procedure of the carrying in the screw repeat as well for the lower (down) position of the aperture.

The cottored joints

Cotters keys connect shafts and hubs of the cog gears, couplings and others. The essential characteristic of the connection with the cotter key, is the possibility of the transfer of relatively great rotary moments and possibly axial forces. Their assembly and disassembly out of the fit is relatively simple. They are being connected by the cotteners with the shaft of the arm pulley, cog wheels, flywheels with the crank shafts, levers, couplings and similar. There are many standard forms of keys: longitudinal and transversal, with the camber angle or without it. In modern constructional solutions the most frequent are longitudinal cotteners without inclination. These cotteners keys are set by solid fitting in the shaft groove. In the hub key – way the resting is loose.

Entering the groove and cutter keyon the right side of the shaft

- From the pallet of the tools Content, activate the icon command Parallel / Woodruff Keys, and so is opened the dialogue Select a Key or Hub.

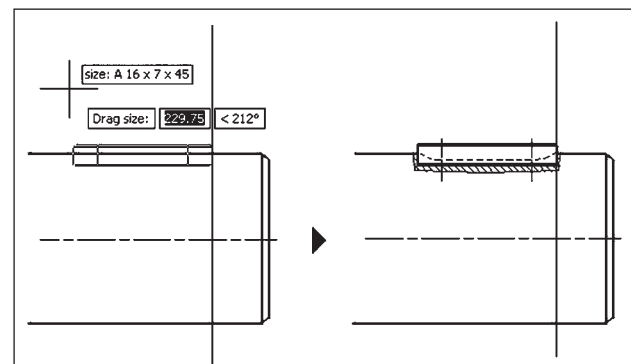

Figure 9 The phases of the creating of the flute and the cutter and determining of the appropriate dimensions

Entering the drawings of the central nests on the shaft

- The finished fit in one projection is given in the following Figures 10, and 11 respectively.

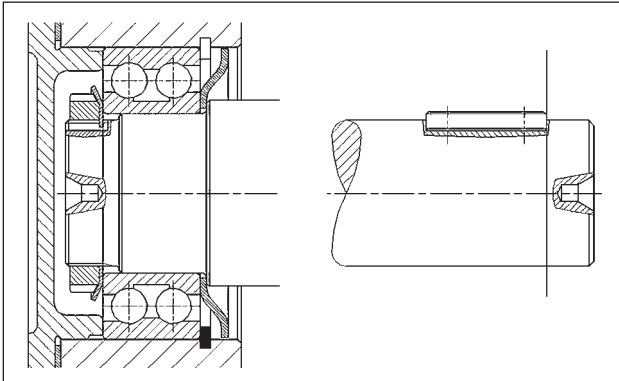

Figure 10 The inserted central nests on the shaft ends

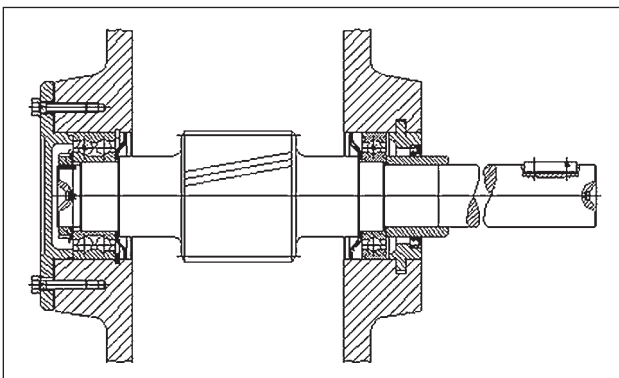

Figure 11 The formed drawing of the fit of the gearing shaft

CONCLUSION

The procedures of the entering of the finished elements for the experienced designers are not now a great problem taking into consideration the disposability of the high – sophisticated softwares as AutoCAD Mechanical and for the planning of the complex projects MS Project. In those terms can be combined as well their information relations, so these procedures become more compatible and more efficient.

REFERENCES

- [1] K. Lee, Principles of CAD/CAM/CAE systems, Addison – Wesley, USA, (1999), p. 88.
- [2] B. Grizelj, I. M. Kenter, P. Jović, Potpora računala primjenom CAD-CAM u planiranju alata i tehnološkom optimiranju, *Metalurgija* 40(2001)2, 91-93.
- [3] D. Letić, B. Davidović, E. Desnica, AutoCAD Mechanical 2011, Computer library, Belgrade, (2011), p. 2-17
- [4] P. Virdzek, K. Teplická, Napredne metode u dizajnu i njihova primjena u strojarstvu, *Metalurgija* 45(2006)4, 347-351.
- [5] J. Heizer, B. Render, Operation s management, 8th ed. Pearson, Prentice Hall, New Jersey, (2011), p. 93-113.
- [6] R. Celin, D. Kmetič, The cracks in the cylindrical bearing, *Metallurgy periodical*, 47 (2008)1, 69-72.

Note: The responsible translator of English language is Srđan Šerer, Technical Faculty “M. Pupin”, Zrenjanin, University of Novi Sad, Serbia