

**Study for the Sonar Target Pattern Recognition  
Based on the Acoustic Scattering Features**

**2000 2**

(認准) .

인

인

인

2000年 2月

# **Study for the Sonar Target Pattern Recognition Based on the Acoustic Scattering Features**

*by*

*Joo Jaehoon*

Department of Ocean Engineering  
Graduate School, Korea Maritime University

## **ABSTRACT**

The objects of active sonar are to detect targets and further to acquire their information such as target specification, dimension, motion and state, after processing their echoes. Especially, classification and discrimination of target using active sonar need to utilize the advanced analysis of target echo features.

Specular reflection and scattering from surface irregularities and inner structures contribute to the target echoes. Since contributors of echoes vary with the target kind and target aspect angle, they constitute basic features of the target signal. Feature parameters of the experimental target signal were extracted in three ways which are the envelope in time domain, the time separation pitch in frequency domain, and the short time Fourier transform in time-frequency domain. The extracted features were applied to the pattern recognition techniques to classify and discriminate target.

Classifying and discriminating similarly shaped targets of which dominant component of the echo is specular reflection result in poor assortment and identification. However, the results show better performance when the effect of inner structures appears in target echoes at the specific aspect angle.

ABSTRACT .....	
Glossary .....	
List of figures .....	
List of tables .....	
1. ....	1
2. ....	3
3. ....	7
3.1 .....	7
3.2 .....	9
4. ....	13
4.1 .....	13
4.2 .....	15
5. ....	17
5.1 .....	17
5.2 .....	23
5.3 - .....	31
6. ....	33
6.1 .....	33
6.2 .....	39
6.3 - .....	45
7. ....	47
.....	48

## *Glossary*

$EL$	Echo Level
$d_k$	Euclidean distance
$E_i$	Input pattern
$E_i(k)$	Reference pattern
$x_a(t)$	Analytic signal of $x(t)$
$u(f)$	Frequency domain unit step function
$\hat{x}(t)$	Hilbert transform of $x(t)$
$TSP$	Time Separation Pitch
$LPC$	Linear Predictive Coding
$PARCOR$	Partial Corelation
$S_R(f)$	Real part of $S(f)$
$S_I(f)$	Imaginary part of $S(f)$
$HL$	Highlight
$TSR$	Time Separation Rate
$\Delta f$	Frequency interval
$f_s$	Sampling frequency
$\Delta r$	Range resolution
$ts$	Time Separation
$ts_{\max}$	Maximum Time Separation
$\Delta ts$	Time Separation interval
$SNR$	Signal to Noise Ratio
$SPEC_x(t, f)$	Spectromgram of the $x(t)$
$h(u - t)$	Hanning window
$I_d$	Discrimination index

## List of figures

Fig. 1	Various feature parameters of the target signal .....	1
Fig. 2.1	Setup for the acoustic scattering experiment .....	3
Fig. 2.2	Experimental targets .....	5
Fig. 2.3	Definition of the aspect angle .....	6
Fig. 3.1	Comparison of the each target signal .....	9
Fig. 3.2	The effect of the inner structures (Aspect angle : 50 °) .....	10
Fig. 3.3	Target signal in case of filling water in the tank or not (pulse 1) .....	10
Fig. 3.4	Comparison of the echo level (transmitted pulse : pulse 3) .....	11
Fig. 3.5	Echo level of the target 3 .....	12
Fig. 3.6	Echo level of the target 4 .....	12
Fig. 4.1	Classifying procedure of the target signal pattern .....	13
Fig. 4.2	Pattern recognition procedure .....	14
Fig. 5.1.1	Peak detection of highlights using envelope of the target signal .....	19
Fig. 5.1.2	The envelope of the target signal due to pulse 1 (10 °) .....	20
Fig. 5.1.3	The target signal due to pulse 3 (180 °) .....	21
Fig. 5.1.4	The impulse response of the target signal and envelope (pulse 3) .....	21
Fig. 5.1.5	Feature parameters of the target 4 using envelope (pulse 1) .....	22
Fig. 5.1.6	Feature parameters of the target 4 using envelope (pulse 3) .....	22
Fig. 5.2.1	TSP of the signal with two highlights .....	23
Fig. 5.2.2	Target signal and spectrum (pulse 1) .....	25
Fig. 5.2.3	Target signal and spectrum (pulse 2) .....	26
Fig. 5.2.4	Target signal and spectrum (pulse 3) .....	26
Fig. 5.2.5	Target 4 signal and extracted TSP due to pulse 1(aspect angle 0 °) ..	29
Fig. 5.2.6	Target 4 signal and extracted TSP due to pulse 3(aspect angle 0 °) ..	29
Fig. 5.2.7	Extracted feature parameters from the target 3 using TSP : pulse 1 ...	29
Fig. 5.2.8	Extracted feature parameters from the target 4 using TSP : pulse 1 ...	30
Fig. 5.2.9	Extracted feature parameters from the target 4 using TSP : pulse 3 ...	30
Fig. 5.3.1	Spectrogram of the target 4 signal due to pulse 3 .....	31
Fig. 6.2.1	The discrimination index of the frequency domain feature parameter ...	39
Fig. 6.3.1	The discrimination index of the time-frequency domain feature parameter .....	45

## List of tables

Table 2.1	Transmitted pulses used at the experiment .....	4
Table 4.1	Feature Parameter of speech and sonar signal .....	15
Table 5.1	Time separation between each highlight .....	28
Table 6.1.1	Similar patterns of the target 1 using time domain feature parameter .....	34
Table 6.1.2	Similar patterns of the target 2 using time domain feature parameter .....	34
Table 6.1.3	Similar patterns of the target 3 using time domain feature parameter .....	35
Table 6.1.4	Similar patterns of the target 4 using time domain feature parameter .....	36
Table 6.1.5	The results of classification of similarly shaped targets using time domain feature parameter .....	37
Table 6.1.6	The results of aspect angle classification of target 4 using time domain feature parameter .....	38
Table 6.2.1	Similar patterns of the target 1 using frequency domain feature parameter .....	40
Table 6.2.2	Similar patterns of the target 2 using frequency domain feature parameter .....	40
Table 6.2.3	Similar patterns of the target 3 using frequency domain feature parameter .....	41
Table 6.2.4	Similar patterns of the target 4 using frequency domain feature parameter .....	42
Table 6.2.5	The results of classification of similarly shaped targets using frequency domain feature parameter .....	43
Table 6.2.6	The results of aspect angle classification of target 4 using frequency domain feature parameter .....	44
Table 6.3.1	The results of aspect angle classification of target 4 using time-frequency domain feature parameter .....	46

1.

가 , ,  
(classification) (discrimination)

가 [1].  
가  
가  
[2][3].

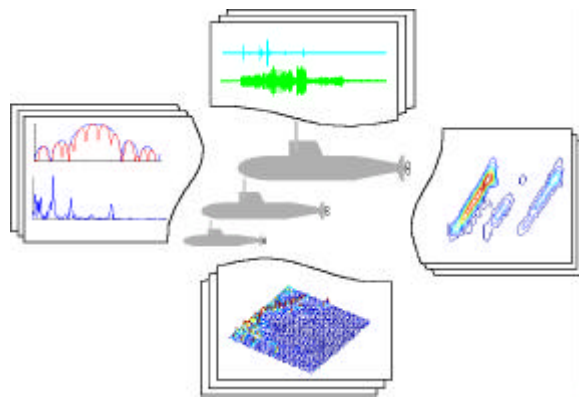

Fig. 1 Various feature parameters of the target signal

가



[4][5].

가

[1][6][7].

가

가

가

가

[4][8- 12].

가

[1][7][13].

2

3

4

가

5

가

TSP(Time Separation Pitch)

FFT

TSP

6

5

7

2.

가

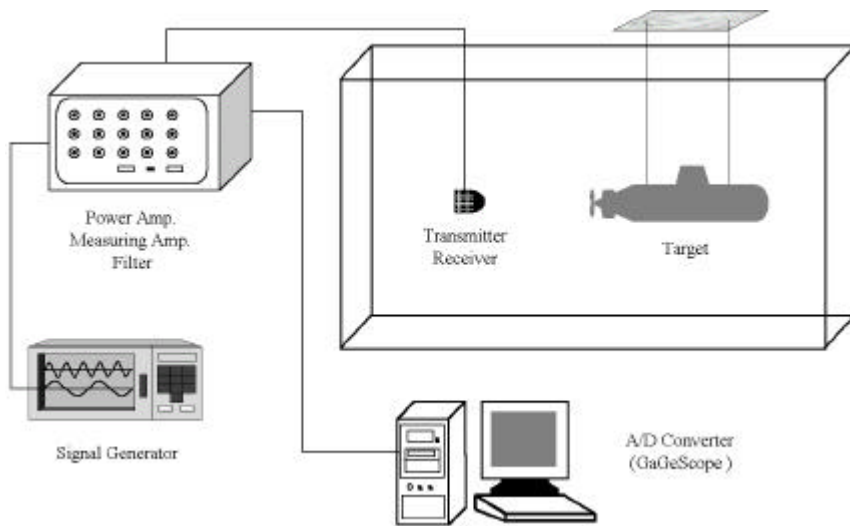

Fig. 2.1 Setup for the acoustic scattering experiment

Fig. 2.1

PRI(Ping Repetition Interval)

가

Tone Burst

LFM(Linear FM)

HP 33120A (gate)

(Power Amplifier)

(Source Level)

(transmitter)

(receiver)

mono- static

(Measuring Amplifier) A/D

(data recorder)

Table 2.1 Transmitted pulses used at the experiment

Tone Burst	36 $\mu s$	420kHz	.	1 (Pulse1)
Tone Burst	1.5ms	420kHz	.	2 (Pulse2)
Linear FM	1.0ms	420kHz	30kHz	3 (Pulse3)
Linear FM	1.5ms	420kHz	20kHz	4 (Pulse4)

Tone Burst LFM

420kHz

Table

2.1

가 4

. Fig. 2.2

1

2

(ring stiffener)가 , 3 가

가 . 4

(conning tower)

가 .

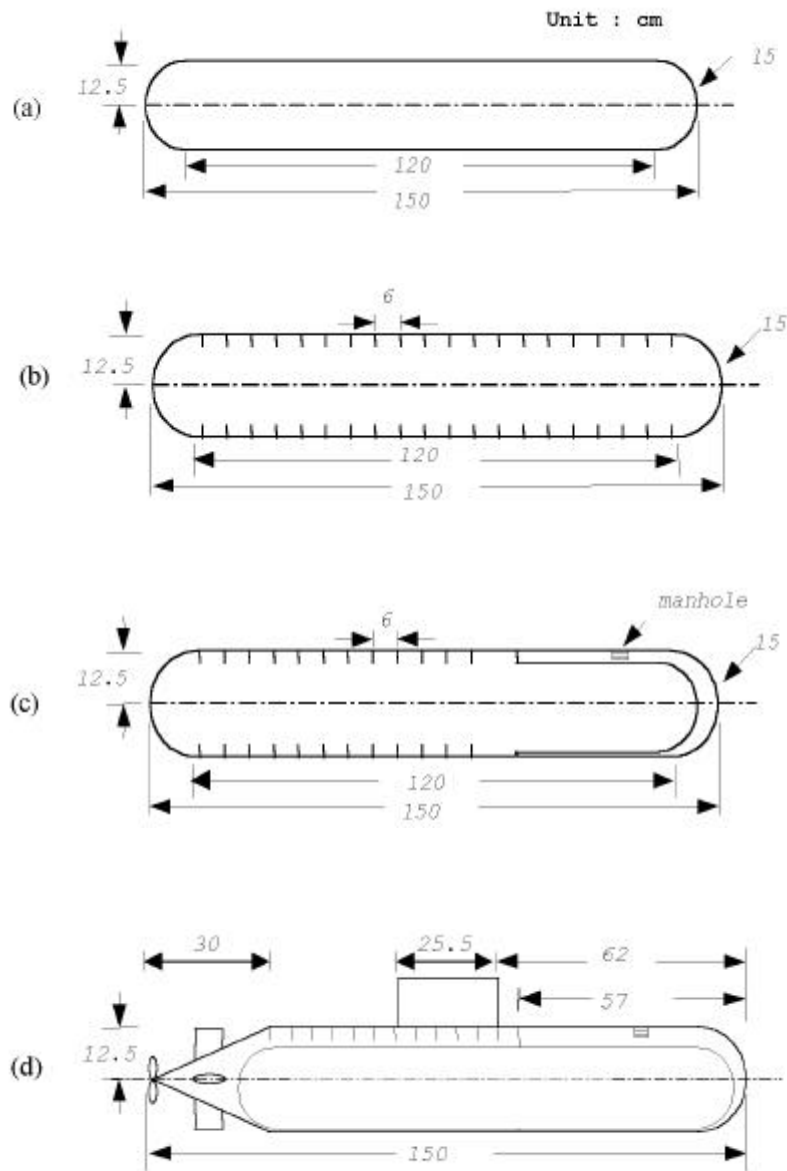

Fig. 2.2 Experimental targets : (a) target 1, (b) target 2, (c) target 3, (d) target 4

0 1, 2  
 3, 4  
 . Fig. 2.3 0 5 1, 2 90  
 3, 4 180

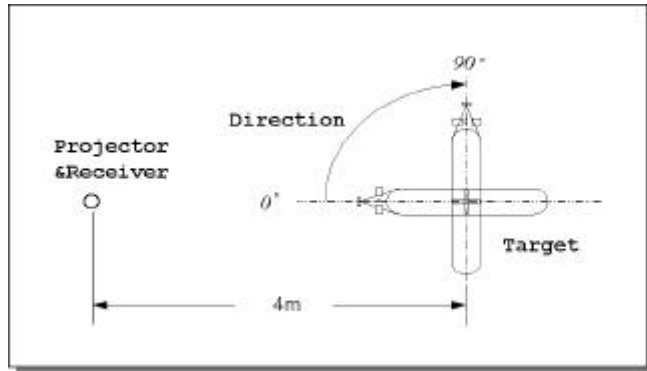

Fig. 2.3 Definition of the aspect angle

### 3.

#### 3.1

(parameter)가 .  
(projector)  
( $\lambda$ ) .  
 $2\pi/\lambda$  'k' ,  
( , ) 'a'  
 .  $ka$  ,  $k$   $a$  .  $ka$   
가 *Rayleigh* , (resonance) ,  
(physical optics) , (geometric optics) .  
1  $ka$  가 가 [14].  
*Rayleigh*  $ka$  1 .  
*Rayleigh* ' ' 가 .  
가 ,  $ka$  1  
 .  
 , 1  $ka$  가 . *hard-boundary*  
*soft-boundary* 가 'creeping wave'  
 $ka$  10 .  
(specular  
reflection)가 , [4][14].  
 .  $ka$   
100 , (edge)  
(corner) .  
 . 420kHz  
0.25m, 가 1.5m  $ka$  400

(shadow boundary) 가  
*circumferential wave*,

*circumferential Lamb wave*가

[1].

가

가

0

(aspect angle) 가

[18].

가

(sphere)

(stationary condition)

가

가  
(bow)

가

가  
(hanging ring)

가

(ballast tank)

(highlight)

가

가

### 3.2

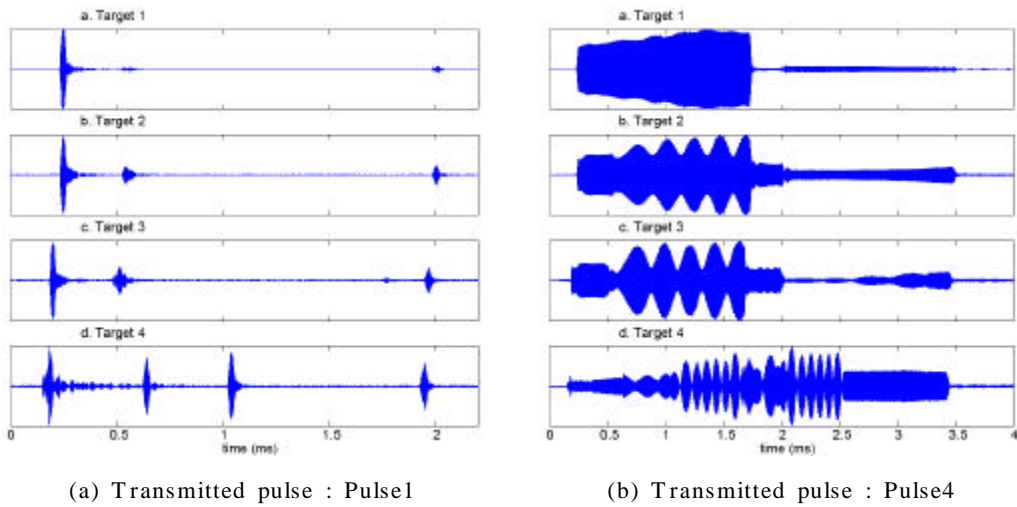

Fig. 3.1 Comparison of the each target signal

Fig. 3.1 가 1, 2, 3, 4 0  
 . Fig. 3.1 (a) 가 1 ,  
 1, 2, 3 가 ,  
 0 가

. Fig. 3.1(b)

Fig. 3.1(a)

. 1 가  
 가  
 , 가 2 3 가

Fig. 3.2

가 1 50 1, 2, 3  
 가 , 0.5ms 1.0ms



가

(impedance) ( 32 )

( 3458 )

가

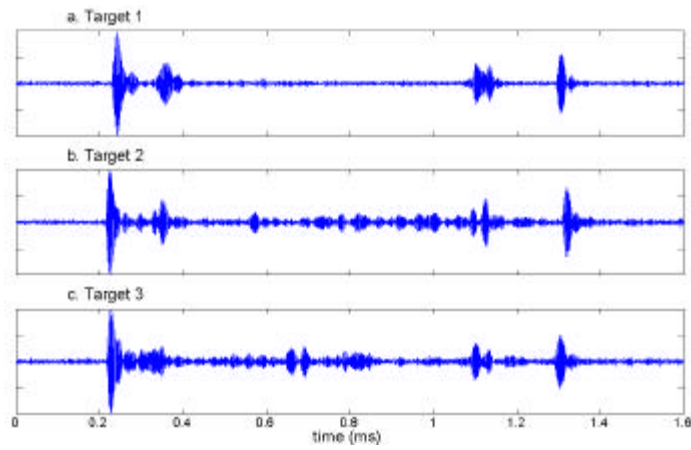

Fig. 3.2 The effect of the inner structures (Aspect angle : 50deg)

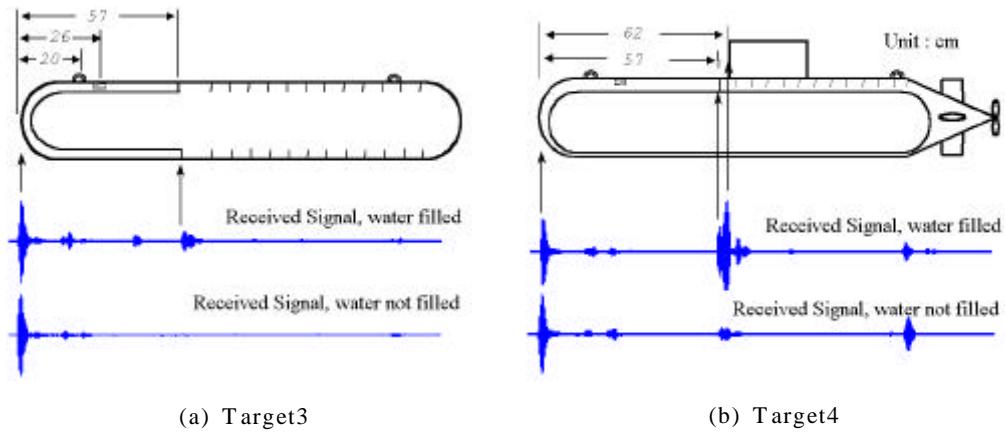

Fig. 3.3 Target signal in case of filling water in the tank or not (pulse 1)

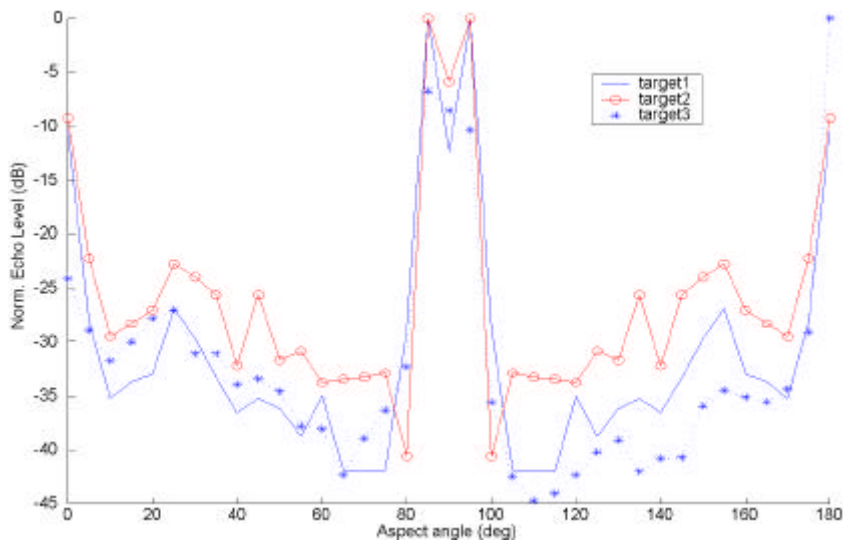

Fig. 3.4 Comparison of the echo level (transmitted pulse : pulse 1)

Fig. 3.4 가 1 1, 2, 3

$$r(t) \quad (EL) \quad (3.1)$$

$$EL = 10 \log \left[ \int_{t_1}^{t_2} r^2(t) dt \right] \quad (3.1)$$

0 90 가  
 , 가

Fig. 3.5 3.6 3 4

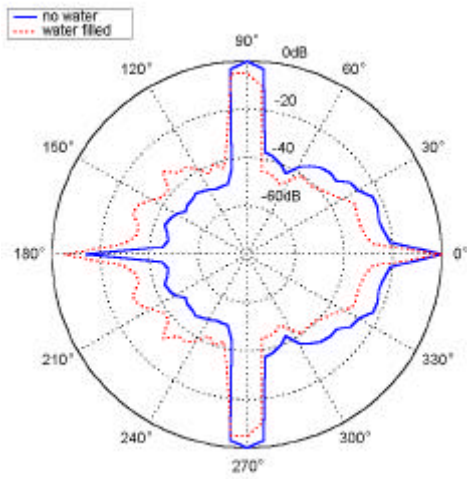

(a) Transmitted pulse : Pulse 1

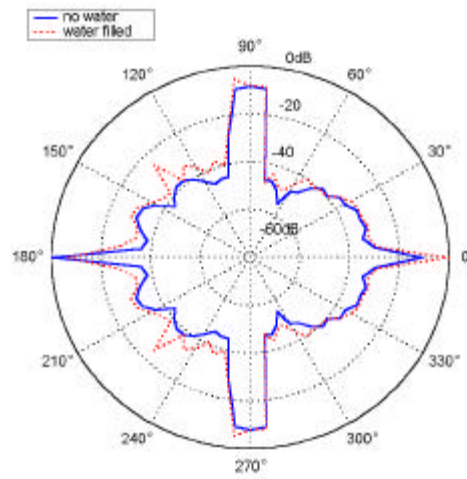

(b) Transmitted pulse : Pulse 3

Fig. 3.5 Echo level of the target 3

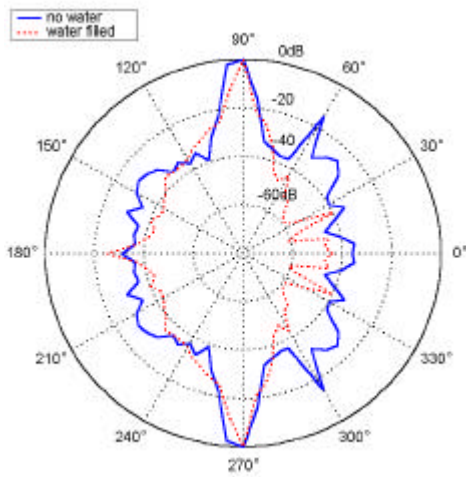

(a) Transmitted pulse : Pulse 1

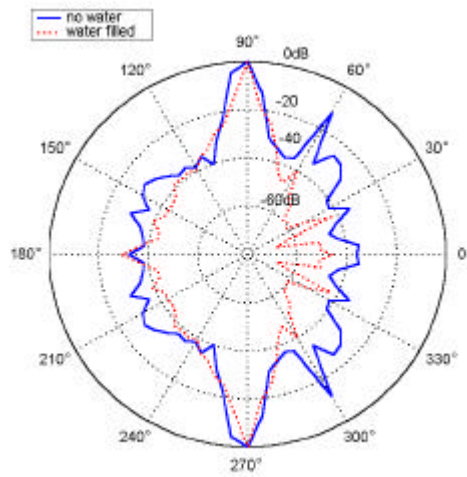

(b) Transmitted pulse : Pulse 3

Fig. 3.6 Echo level of the target 4

4.

4.1

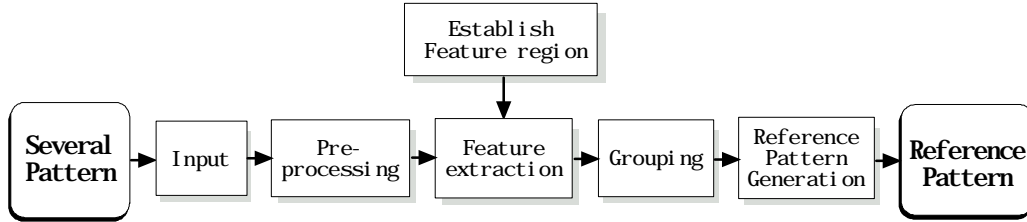

Fig. 4.1 Classifying procedure of the target signal pattern

, , , ,  
 , (seismic wave) (concert pattern)  
 , , (abstract  
 pattern) .  
 가 가 . 가

. , (class)  
 . (category)

(decision rule) [20].

Fig. 4.1

A/D ,  
 (normalization)

(clustering)

(reference data)

[10][20].

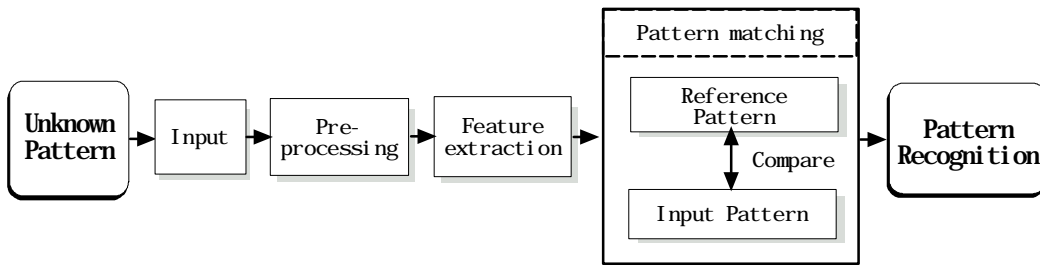

Fig. 4.2 Pattern recognition procedure

(test data)

Fig. 4.2

(pattern matching)

(similarity measure)

(Euclidean

distance), (inner product distance),

(maximum likelihood

ration) 가 가 ,

$E_i, E_i(k),$

$i = 1, 2, \dots, N$

(4.1)

[10][16].

$$d_k = \sqrt{\sum_{i=1}^N [E_i - E_i(k)]^2} \quad (4.1)$$

$k$  가 가 ,  $d_k$  가 가

가 [10].

## 4.2

가 가 , 가

가  
(matching)

Table 4.1 Feature Parameter of speech and sonar signal

Feature Parameter	
Speech Signal	Active Sonar Signal
<ul style="list-style-type: none"><li>• Correlation Coefficient</li><li>• Cepstrum</li><li>• LPC</li><li>• PARCOR</li></ul>	<ul style="list-style-type: none"><li>• Highlight</li><li>• TSP</li><li>• Spectrogram Coefficient</li></ul>

가 가

가

가 가

[7][8].

(cepstrum), (LPC),

(PARCOR)

(pitch)

TSP

가 , 가

가 가

가

1

3

1, 2, 3

가 . 3 ka

가

가 가

5.

5.1

3

가

가

가

1, 2, 3

(45 ° 65 °)

(reflection ratio),

(elongation),

가

FFT

(envelope)

(Hilbert)

“ (real)”

(complex)

“ (analytic)”

(imaginary part)가

가

[10].

$x(t)$ 가

가 [10][19].



$$x(t) \leftrightarrow X(f)$$

$$\text{analytic signal} = x_a(t) \leftrightarrow 2u(f)X(f) \quad (5.1.1)$$

$$u(f) \quad (\text{unit step function})$$

$$x(t) \text{ 가 } \quad (5.1.1) \quad , x_a(t)$$

$$(5.1.1)$$

$$\left[ \delta(t) - \frac{1}{j\pi t} \right] \leftrightarrow 2u(f)$$

$$x(t) \leftrightarrow X(f) \quad (5.1.2)$$

$$x_a(t) = x(t) * \left[ \delta(t) - \frac{1}{j\pi t} \right]$$

$$x(t) \quad x(t)$$

$$(5.1.2)$$

$$x_a(t) = x(t) + \frac{j}{\pi} \int_{-\infty}^{\infty} \frac{x(\tau)}{t - \tau} d\tau \quad (5.1.3)$$

$$x_a(t) \quad , \quad (5.1.3) \quad x(t)$$

$$(5.1.3) \quad x(t) \quad (\text{Hilbert transform})$$

$$(5.1.4)$$

$$\hat{x}(t) = \frac{1}{\pi} \int_{-\infty}^{\infty} \frac{x(\tau)}{t - \tau} d\tau \quad (5.1.4)$$

$$(5.1.5)$$

$$x(t) = \frac{1}{\pi} \int_{-\infty}^{\infty} \frac{\hat{x}(\tau)}{t - \tau} d\tau \quad (5.1.5)$$

(5.1.6) ,  $x(t) \quad \hat{x}(t)$  (pair) . ,

$$x_a(t) = x(t) + j\hat{x}(t) \quad (5.1.6)$$

(exponential) , (5.1.7) .

$$x_a(t) = |x_a(t)| \exp [j\phi(t)] \quad (5.1.7)$$

,

$$|x_a(t)| = \sqrt{x^2(t) + \hat{x}^2(t)} \quad (5.1.8)$$

(5.1.8) (envelope function) .

가

(peak) .

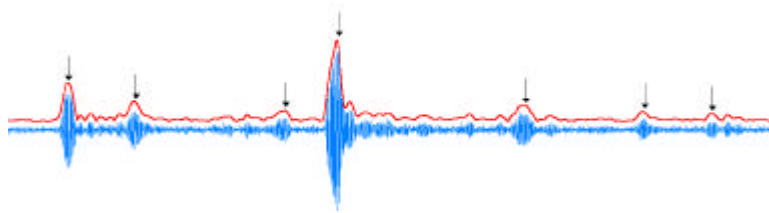

Fig. 5.1.1 Peak detection of highlights using envelope of the target signal

(matched filter) .

가 (+) (-)가  
 0.05 ms (time bin)  
 가  
 (threshold) 가  
 2.2 ms 2.2 / 0.05 = 44  
 가  
 (zero)  
 1, 2 19 (0° 90°, 5°), 3, 4  
 37 (0° 180°, 5°)  
 10

Fig. 5.1.2 가 1 10

Fig. 5.1.3 3

가 3  
 , Fig. 5.1.4

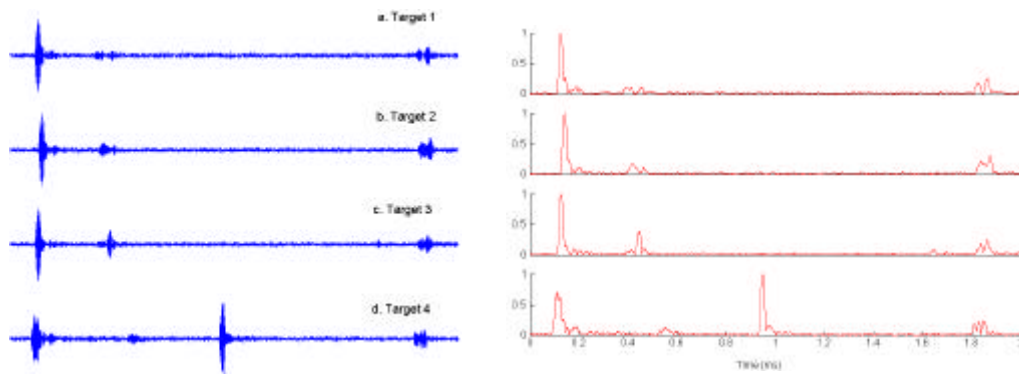

Fig. 5.1.2 The envelope of the target signal due to pulse 1 (aspect angle : 10°)



Fig. 5.1.3 The target signal due to pulse 3 (aspect angle : 180 °)

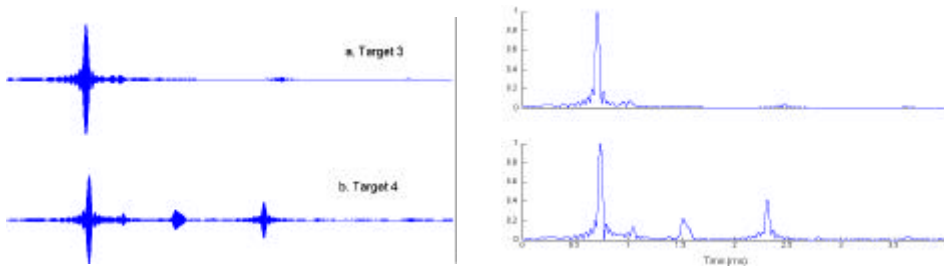

Fig. 5.1.4 The impulse response of the target signal and envelope (pulse 3)

Fig. 5.1.5 가 1 4  
 , Fig. 5.1.6 가 3 4  
 가 가 가 .

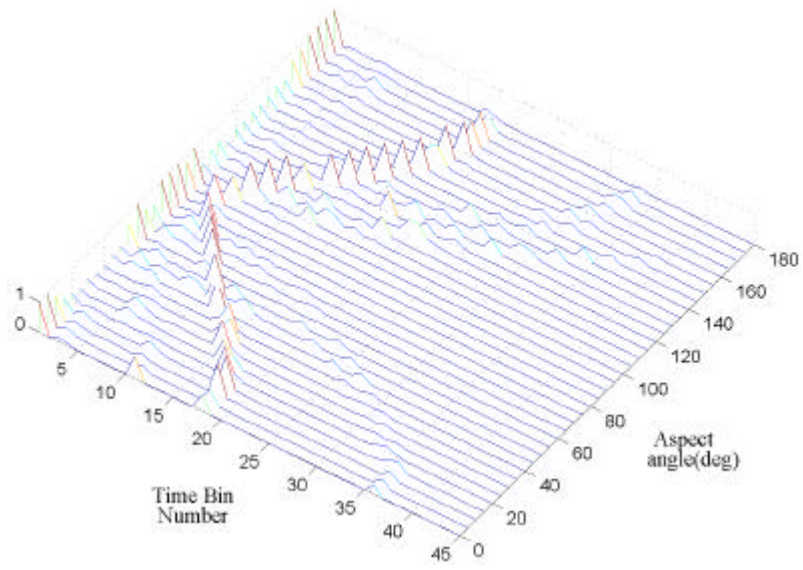

Fig. 5.1.5 Feature parameters of the target 4 using envelope (pulse 1)

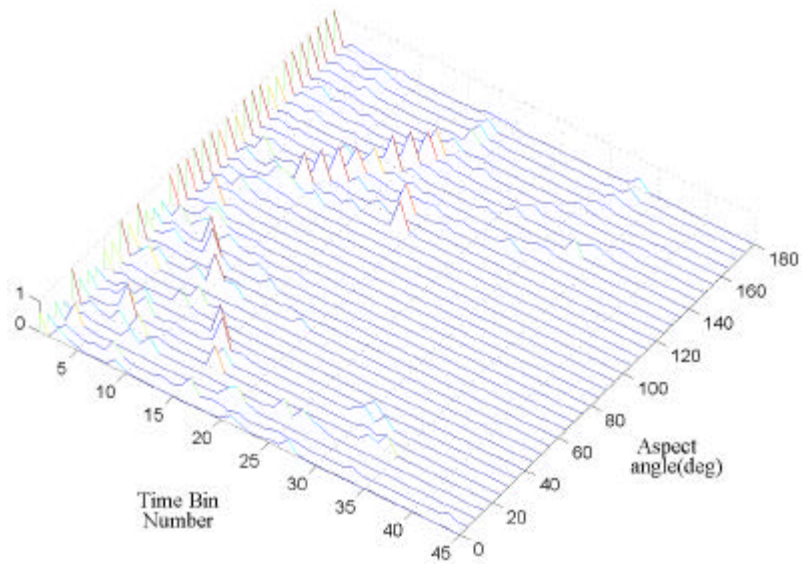

Fig. 5.1.6 Feature parameters of the target 4 using envelope (pulse 3)

## 5.2

Hammer 가 . Thurlow Small  
 TSP(Time Separation Pitch)  
 가  $T$   $1/T$  Hz TSP  
 (pitch) (tonal)  
 가 가 TSP 가 ,  
 periodicity pitch, infra-pitch echo [10].  
 가  
 (replica)

### 5.2.1 TSP

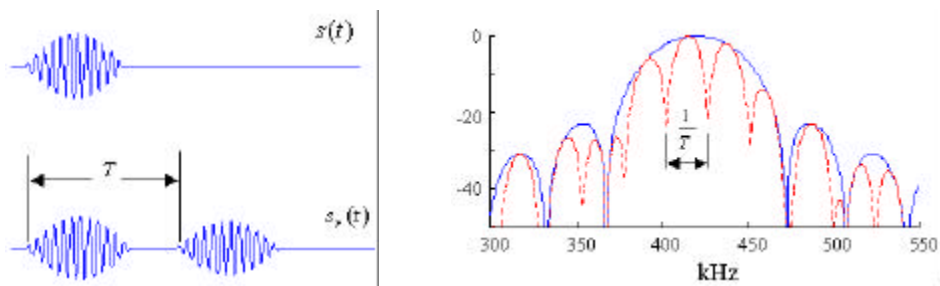

Fig. 5.2.1 TSP of the signal with two highlights

Fig. 5.2.1  $T$  (replica)가

$$s_r(t) = s(t) + a s(t - T) \quad (5.2.1)$$

$$s(t) \quad a \quad s(t) \quad (5.2.1) \quad s_r(t)$$

$$\mathbf{F}[s_r(t)] = S_r(f) = S(f) + a e^{-j2\pi f T} S(f) \quad (5.2.2)$$

(5.2.2) exponential  $S(f)$   
 $S_r(f)$

$$S_r(f) = [S_R(f) + jS_I(f)][1 + a \cos(2\pi f T) - ja \sin(2\pi f T)] \quad (5.2.3)$$

$$S_R(f) = S(f) \cos(2\pi f T), \quad S_I(f) = S(f) \sin(2\pi f T)$$

$$S_r(f) = S_R(f)[1 + a \cos(2\pi f T)] + S_I(f) a \sin(2\pi f T) + j \{S_I(f)[1 + a \cos(2\pi f T)] - S_R(f) a \sin(2\pi f T)\} \quad (5.2.4)$$

$$|\mathbf{F}[s(t) + a s(t - T)]| = \sqrt{1 + a^2 + 2a \cos(2\pi f T)} |S(f)| \quad (5.2.5)$$

$$\phi_r(f) = \tan^{-1} \frac{S_I(f)[1 + a \cos(2\pi f T)] - S_R(f) a \sin(2\pi f T)}{S_R(f)[1 + a \cos(2\pi f T)] + S_I(f) a \sin(2\pi f T)} \quad (5.2.6)$$

$$(5.2.5) \quad \cos(2\pi f T)$$

(peaks)  $\cos(2\pi f T) = 1$

$$f = (n - 1) \frac{1}{T} \quad n = 1, 2, 3, \dots \quad (5.2.7)$$

(troughs)  $\cos(2\pi fT) = -1$

$$f = \frac{(2n - 1)}{2T} \quad n = 1, 2, 3, \dots \quad (5.2.8)$$

Fig. 5.2.2, 5.2.3 5.2.4 가 1, 2, 3  
 가 139  $\mu s$   
 , TSP 7.2kHz 가 1  
 7.2kHz TSP가 , 가 2 1  
 가 TSP  
 3 가  
 가 1 가 TSP가

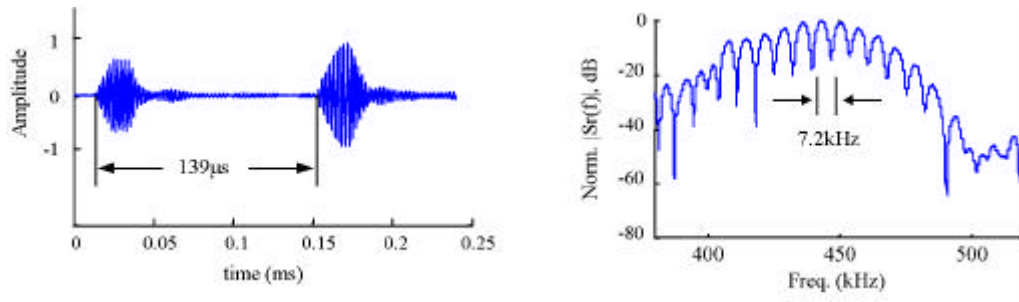

Fig. 5.2.2 Target signal and spectrum (pulse 1)



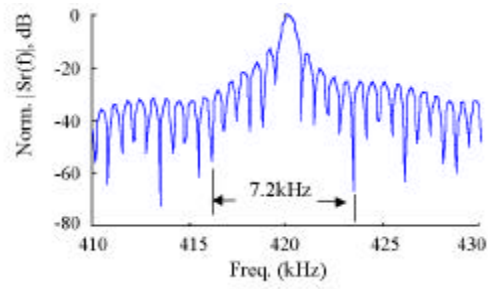
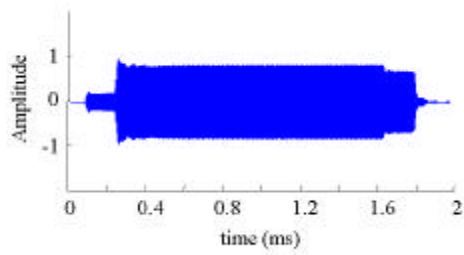

Fig. 5.2.3 Target signal and spectrum (pulse 2)

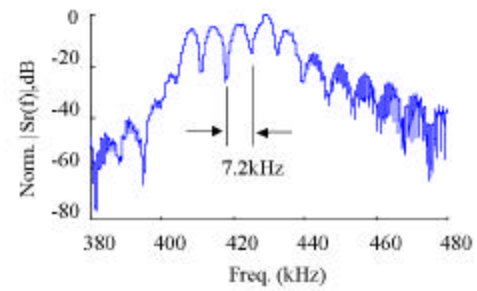
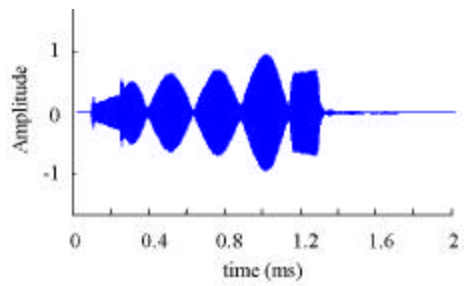

Fig. 5.2.4 Target signal and its spectrum (pulse 3)

## 5.2.2 TSP

가 TSP  
 가 TSP  
 가 TSP  
 가 TSP  
 가 TSP  
 가 TSP  
 (modulus)  
 FFT TSP

(oscillation) , TSP . TSP

, TSP 가  
TSP .

$\Delta f$  FFT  $N$  가 .

$$\Delta f = \frac{f_s}{N} \quad (5.2.9)$$

(side lobe) , FFT “  
(time separation)” . FFT

“ ” . (5.2.9)  $\Delta f$

(5.2.10)  $TSR$  (Time Separation Rate) .

(interval) (5.2.11) .

$$TSR = \frac{1}{\Delta f} = \frac{N}{f_s} \quad (5.2.10)$$

$$\Delta ts = \frac{TSR}{N'} \quad (5.2.11)$$

$N'$  FFT .  $\Delta ts$

.  $\Delta r$   $\Delta ts$   $c$  (5.2.12) .

$$\Delta r = \frac{c \Delta ts}{2} \quad (5.2.12)$$

$$\Delta r = 2\text{cm} \quad (5.2.13)$$

$$ts = (0, 1, 2, \dots, N' - 1) \times \Delta ts \quad (5.2.13)$$

$$TSR = (ts_{\max})^2$$

$$TSR = \frac{N}{f_s} \geq 2ts_{\max} \quad (5.2.14)$$

Fig. 5.2.5 Fig. 5.2.6 1 3 4  
0 TSP

Fig. 5.2.5 0.086ms, 0.546ms, 0.945ms, 1.842ms

4 가 ,  
가 가 . 4  
0.460ms,

0.859ms, 1.756ms, 0.399ms, 1.296ms, 0.897ms 6 . Fig. 5.2.5 Fig. 5.2.6  
SNR TSP

5 TSP 가 0.460ms, 0.860ms, 1.755ms, 1.305ms

Table 5.1 Time separation between each highlight

HL	HL1	HL2	HL3	HL4
	0.086ms	0.546ms	0.945ms	1.842ms
0.086 ⇨	.	0.46ms	0.859ms	1.756ms
	0.546 ⇨	.	0.399ms	1.296ms
		0.945 ⇨	.	0.897ms
			1.842 ⇨	.

Fig. 5.2.7 가 1 3 TSP  
 . Fig. 5.2.8 5.2.9 가 1, 3  
 4 TSP . 가  
 TSP 가 (bin) ,  
 . 가  
 가 가 .

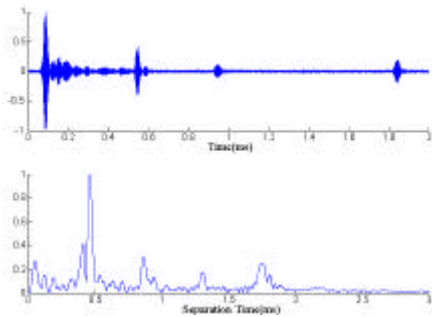

Fig. 5.2.5 Target 4 signal and extracted TSP due to pulse 1 (0°)

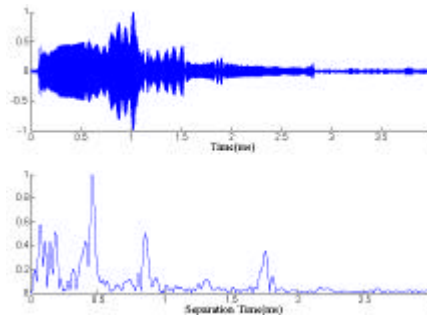

Fig. 5.2.6 Target 4 signal and extracted TSP due to pulse 3 (0°)

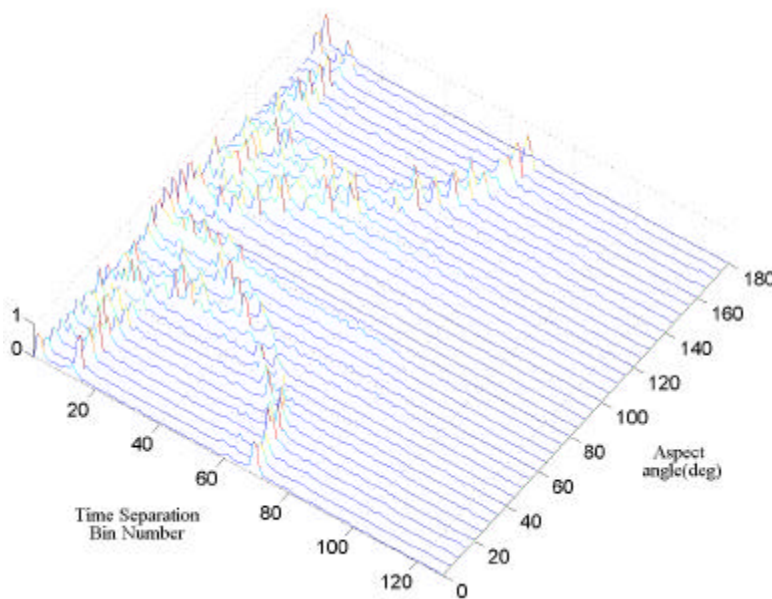

Fig. 5.2.7 Extracted feature parameters from the target 3 using TSP : pulse 1

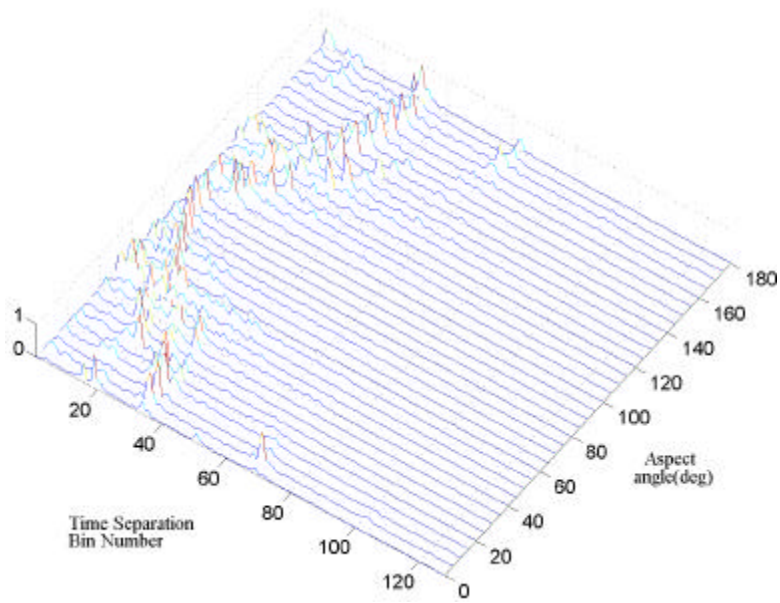

Fig. 5.2.8 Extracted feature parameters from the target 4 using TSP : pulse 1

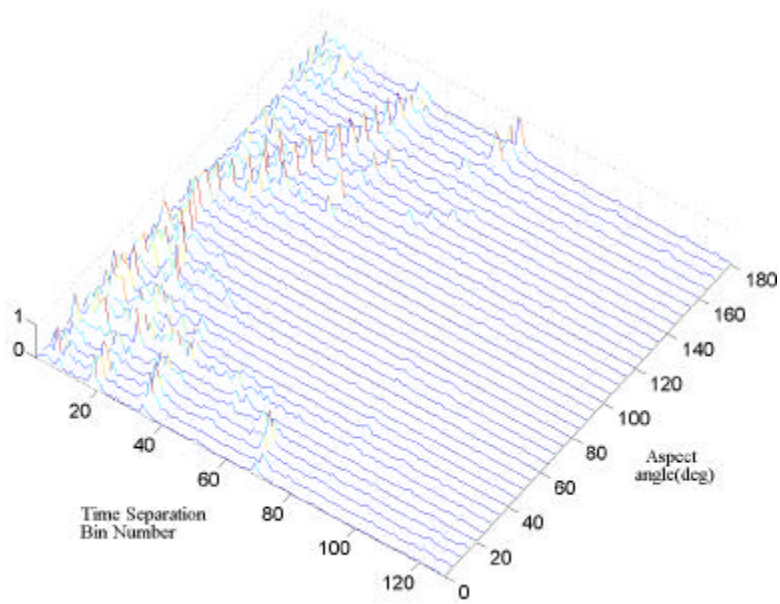

Fig. 5.2.9 Extracted feature parameters from the target 4 using TSP : pulse 3

5.3 -

가 (transient signal)  
 가 가 . LFM  
 가  
 [8][15]. - STFT(Short Time Fourier Transform),  
 Wigner- Ville Distribution, Rihaczek Distribution wavelet transform  
 , (hanning) STFT  
 - . (5.3.1)

$$SPEC_x(t, f) = \left| \int_{-\infty}^{+\infty} x(u) h(u - t) e^{-j2\pi fu} du \right|^2 \quad (5.3.1)$$

$x(u) h^*(u - t)$  가  
 Fig. 5.3.1 4 가 .

가 -  
 가 .  
 ,  
 2 가

[10].

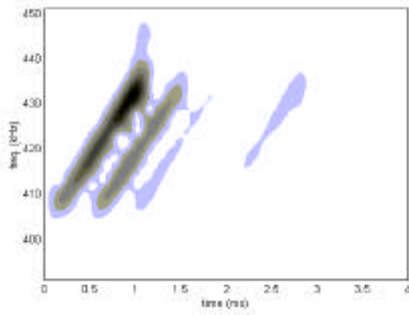

(a) 0°

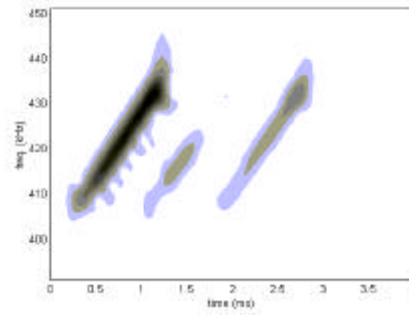

(b) 180°

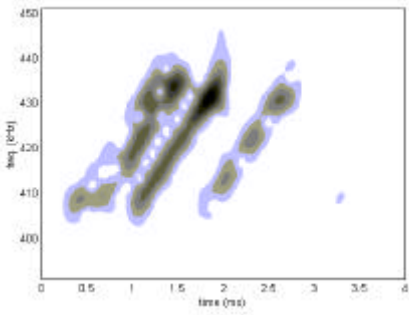

(c) 30°

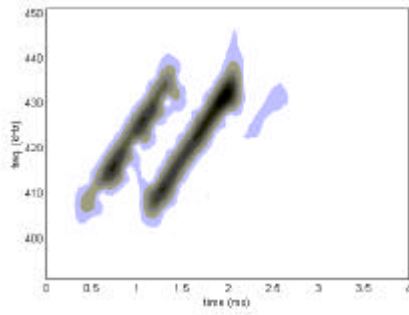

(d) 150°

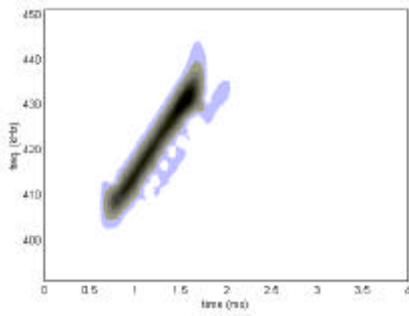

(e) 60°

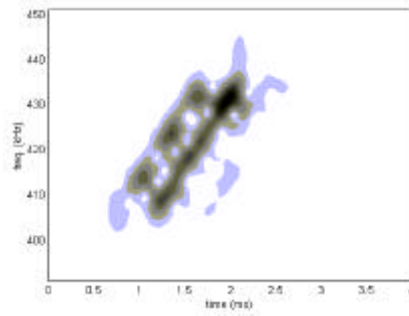

(f) 120°

Fig. 5.3.1 Spectrogram of the target 4 signal due to pulse 3

6.

6.1

$$(6.1.1)$$

$$d_E(i) \text{ for } d_E(1) < d_E(2) < \dots < d_E(N), \quad i = 1, 2, 3, \dots, N \quad (6.1.1)$$

$d_E(N) = 1$ ,  $1$  . 4  
 $d_E(i)$ 가 가 가 .  
 (discrimination index)  $I_d$  가  $d_E(i)$  9 (6.1.2)

$$I_d = \frac{\left| \sum_{i=2}^9 [d_E(i) - d_E(1)] \right|}{8} \quad (6.1.2)$$

$I_d$ 가 가 ,  
 $d_E(1)$ 가 .  $I_d$   
 가 .  
 Table. 6.1.1, 6.1.2, 6.1.3 6.1.4 1, 2, 3, 4 가  
 5 ( $I_d$ ) .  
 1 55 , 2 50 , 3 50 130 , 4  
 45 100 . 가 1 90 ,  
 2 80 , 3 80 95 , 4 60 180  
 , 가 1 90 2 90 , 3 90 , 1  
 90 , 2 85 , 3 85 가 가 .



Table 6.1.1 Similar patterns of the target 1  
using time domain feature parameter

	1st class	2nd class	3rd class	4th class	5th class	$I_d$		1st class	2nd class	3rd class	4th class	5th class	$I_d$
0°	5° <sup>1</sup>	0° <sup>2</sup>	5° <sup>1</sup>	90° <sup>2</sup>	85° <sup>3</sup>	0.051	50°	50° <sup>1</sup>	80° <sup>3</sup>	85° <sup>2</sup>	90° <sup>2</sup>	90° <sup>3</sup>	0.146
5°	5° <sup>1</sup>	0° <sup>2</sup>	0° <sup>1</sup>	5° <sup>2</sup>	10° <sup>1</sup>	0.071	55°	55° <sup>1</sup>	55° <sup>2</sup>	60° <sup>1</sup>	90° <sup>2</sup>	30° <sup>2</sup>	0.234
10°	10° <sup>1</sup>	5° <sup>2</sup>	10° <sup>2</sup>	0° <sup>3</sup>	5° <sup>3</sup>	0.070	60°	60° <sup>1</sup>	90° <sup>1</sup>	85° <sup>3</sup>	85° <sup>1</sup>	85° <sup>2</sup>	0.075
15°	15° <sup>1</sup>	5° <sup>3</sup>	10° <sup>2</sup>	10° <sup>1</sup>	10° <sup>3</sup>	0.092	65°	65° <sup>1</sup>	65° <sup>2</sup>	90° <sup>1</sup>	90° <sup>2</sup>	85° <sup>3</sup>	0.133
20°	20° <sup>1</sup>	20° <sup>2</sup>	25° <sup>1</sup>	25° <sup>2</sup>	25° <sup>3</sup>	0.140	70°	70° <sup>1</sup>	70° <sup>3</sup>	70° <sup>2</sup>	80° <sup>2</sup>	80° <sup>3</sup>	0.103
25°	25° <sup>1</sup>	20° <sup>2</sup>	30° <sup>1</sup>	20° <sup>1</sup>	25° <sup>3</sup>	0.053	75°	75° <sup>1</sup>	70° <sup>3</sup>	70° <sup>1</sup>	75° <sup>2</sup>	80° <sup>1</sup>	0.067
30°	30° <sup>1</sup>	30° <sup>3</sup>	25° <sup>1</sup>	90° <sup>2</sup>	90° <sup>3</sup>	0.093	80°	80° <sup>1</sup>	90° <sup>3</sup>	90° <sup>2</sup>	90° <sup>1</sup>	80° <sup>3</sup>	0.045
35°	35° <sup>1</sup>	40° <sup>4</sup>	35° <sup>2</sup>	40° <sup>1</sup>	80° <sup>3</sup>	0.105	85°	85° <sup>3</sup>	85° <sup>1</sup>	90° <sup>1</sup>	85° <sup>2</sup>	90° <sup>3</sup>	0.045
40°	40° <sup>1</sup>	45° <sup>2</sup>	80° <sup>3</sup>	45° <sup>1</sup>	85° <sup>2</sup>	0.129	90°	90° <sup>2</sup>	90° <sup>3</sup>	90° <sup>1</sup>	85° <sup>2</sup>	85° <sup>3</sup>	0.039
45°	45° <sup>1</sup>	75° <sup>3</sup>	45° <sup>2</sup>	80° <sup>3</sup>	90° <sup>2</sup>	0.084							

Table 6.1.2 Similar patterns of the target 2  
using time domain feature parameter

	1st class	2nd class	3rd class	4th class	5th class	$I_d$		1st class	2nd class	3rd class	4th class	5th class	$I_d$
0°	5° <sup>1</sup>	0° <sup>2</sup>	0° <sup>1</sup>	90° <sup>3</sup>	90° <sup>2</sup>	0.043	50°	50° <sup>2</sup>	70° <sup>3</sup>	70° <sup>1</sup>	55° <sup>2</sup>	50° <sup>1</sup>	0.225
5°	10° <sup>2</sup>	5° <sup>2</sup>	10° <sup>1</sup>	0° <sup>3</sup>	5° <sup>3</sup>	0.050	55°	55° <sup>2</sup>	90° <sup>1</sup>	85° <sup>3</sup>	85° <sup>1</sup>	85° <sup>2</sup>	0.090
10°	10° <sup>2</sup>	5° <sup>2</sup>	10° <sup>1</sup>	0° <sup>3</sup>	5° <sup>3</sup>	0.068	60°	60° <sup>1</sup>	50° <sup>1</sup>	85° <sup>4</sup>	90° <sup>3</sup>	90° <sup>1</sup>	0.047
15°	15° <sup>2</sup>	15° <sup>1</sup>	10° <sup>2</sup>	5° <sup>3</sup>	0° <sup>3</sup>	0.156	65°	65° <sup>2</sup>	65° <sup>1</sup>	90° <sup>1</sup>	60° <sup>4</sup>	90° <sup>3</sup>	0.113
20°	20° <sup>2</sup>	20° <sup>1</sup>	25° <sup>1</sup>	25° <sup>2</sup>	25° <sup>3</sup>	0.144	70°	70° <sup>2</sup>	70° <sup>3</sup>	80° <sup>3</sup>	80° <sup>1</sup>	90° <sup>3</sup>	0.063
25°	25° <sup>2</sup>	25° <sup>1</sup>	25° <sup>3</sup>	20° <sup>1</sup>	20° <sup>2</sup>	0.131	75°	75° <sup>2</sup>	80° <sup>3</sup>	80° <sup>1</sup>	90° <sup>3</sup>	90° <sup>2</sup>	0.093
30°	30° <sup>3</sup>	30° <sup>1</sup>	25° <sup>1</sup>	25° <sup>2</sup>	25° <sup>3</sup>	0.167	80°	75° <sup>3</sup>	15° <sup>2</sup>	80° <sup>2</sup>	0° <sup>3</sup>	10° <sup>2</sup>	0.029
35°	35° <sup>2</sup>	35° <sup>3</sup>	35° <sup>1</sup>	45° <sup>1</sup>	70° <sup>2</sup>	0.109	85°	85° <sup>2</sup>	90° <sup>1</sup>	85° <sup>1</sup>	85° <sup>3</sup>	90° <sup>3</sup>	0.030
40°	40° <sup>2</sup>	40° <sup>1</sup>	40° <sup>3</sup>	35° <sup>1</sup>	35° <sup>2</sup>	0.180	90°	90° <sup>2</sup>	90° <sup>3</sup>	90° <sup>1</sup>	85° <sup>2</sup>	85° <sup>3</sup>	0.035
45°	45° <sup>2</sup>	45° <sup>1</sup>	75° <sup>3</sup>	80° <sup>3</sup>	85° <sup>3</sup>	0.063							

Table 6.1.3 Similar patterns of the target 3  
using time domain feature parameter

	1st class	2nd class	3rd class	4th class	5th class	$I_d$		1st class	2nd class	3rd class	4th class	5th class	$I_d$
0°	0° <sup>3</sup>	175° <sup>3</sup>	10° <sup>2</sup>	10° <sup>1</sup>	5° <sup>2</sup>	0.038	95°	90° <sup>1</sup>	85° <sup>3</sup>	85° <sup>1</sup>	95° <sup>3</sup>	90° <sup>2</sup>	0.013
5°	10° <sup>3</sup>	10° <sup>1</sup>	5° <sup>1</sup>	5° <sup>2</sup>	5° <sup>3</sup>	0.123	100°	100° <sup>3</sup>	80° <sup>3</sup>	80° <sup>2</sup>	80° <sup>1</sup>	75° <sup>3</sup>	0.220
10°	10° <sup>3</sup>	10° <sup>1</sup>	60° <sup>4</sup>	5° <sup>2</sup>	5° <sup>3</sup>	0.179	105°	105° <sup>3</sup>	135° <sup>4</sup>	40° <sup>4</sup>	55° <sup>3</sup>	80° <sup>1</sup>	0.187
15°	15° <sup>3</sup>	10° <sup>3</sup>	5° <sup>3</sup>	10° <sup>1</sup>	15° <sup>1</sup>	0.066	110°	110° <sup>3</sup>	50° <sup>2</sup>	100° <sup>3</sup>	70° <sup>1</sup>	75° <sup>1</sup>	0.257
20°	20° <sup>3</sup>	15° <sup>3</sup>	15° <sup>1</sup>	20° <sup>1</sup>	155° <sup>3</sup>	0.192	115°	115° <sup>3</sup>	60° <sup>3</sup>	75° <sup>1</sup>	75° <sup>3</sup>	100° <sup>3</sup>	0.229
25°	25° <sup>3</sup>	25° <sup>1</sup>	25° <sup>2</sup>	30° <sup>1</sup>	30° <sup>3</sup>	0.145	120°	120° <sup>3</sup>	60° <sup>3</sup>	60° <sup>2</sup>	60° <sup>1</sup>	180° <sup>4</sup>	0.331
30°	30° <sup>3</sup>	30° <sup>1</sup>	25° <sup>3</sup>	25° <sup>1</sup>	150° <sup>3</sup>	0.062	125°	125° <sup>3</sup>	55° <sup>2</sup>	55° <sup>3</sup>	55° <sup>1</sup>	70° <sup>2</sup>	0.238
35°	35° <sup>3</sup>	40° <sup>3</sup>	35° <sup>1</sup>	40° <sup>2</sup>	35° <sup>2</sup>	0.149	130°	130° <sup>3</sup>	60° <sup>2</sup>	50° <sup>2</sup>	105° <sup>3</sup>	55° <sup>2</sup>	0.484
40°	40° <sup>3</sup>	40° <sup>1</sup>	30° <sup>3</sup>	70° <sup>2</sup>	30° <sup>1</sup>	0.145	135°	135° <sup>3</sup>	40° <sup>1</sup>	75° <sup>3</sup>	75° <sup>2</sup>	45° <sup>2</sup>	0.228
45°	45° <sup>3</sup>	85° <sup>4</sup>	95° <sup>4</sup>	45° <sup>2</sup>	45° <sup>1</sup>	0.191	140°	140° <sup>3</sup>	40° <sup>2</sup>	40° <sup>1</sup>	150° <sup>3</sup>	50° <sup>1</sup>	0.304
50°	50° <sup>3</sup>	50° <sup>2</sup>	75° <sup>1</sup>	75° <sup>2</sup>	60° <sup>3</sup>	0.275	145°	145° <sup>3</sup>	35° <sup>1</sup>	85° <sup>4</sup>	155° <sup>3</sup>	45° <sup>3</sup>	0.273
55°	55° <sup>3</sup>	55° <sup>1</sup>	55° <sup>2</sup>	45° <sup>2</sup>	85° <sup>4</sup>	0.209	150°	150° <sup>3</sup>	30° <sup>1</sup>	30° <sup>3</sup>	25° <sup>3</sup>	30° <sup>2</sup>	0.174
60°	60° <sup>3</sup>	70° <sup>3</sup>	80° <sup>2</sup>	80° <sup>3</sup>	50° <sup>1</sup>	0.089	155°	155° <sup>3</sup>	25° <sup>2</sup>	25° <sup>1</sup>	25° <sup>3</sup>	20° <sup>1</sup>	0.153
65°	65° <sup>3</sup>	65° <sup>1</sup>	65° <sup>2</sup>	60° <sup>4</sup>	80° <sup>2</sup>	0.252	160°	160° <sup>3</sup>	20° <sup>2</sup>	30° <sup>3</sup>	20° <sup>1</sup>	150° <sup>3</sup>	0.207
70°	70° <sup>3</sup>	70° <sup>1</sup>	80° <sup>2</sup>	90° <sup>2</sup>	180° <sup>3</sup>	0.063	165°	165° <sup>3</sup>	10° <sup>2</sup>	15° <sup>2</sup>	10° <sup>1</sup>	5° <sup>3</sup>	0.121
75°	75° <sup>3</sup>	75° <sup>2</sup>	80° <sup>3</sup>	95° <sup>3</sup>	180° <sup>3</sup>	0.102	170°	170° <sup>3</sup>	20° <sup>1</sup>	20° <sup>2</sup>	15° <sup>1</sup>	15° <sup>3</sup>	0.209
80°	90° <sup>3</sup>	80° <sup>3</sup>	90° <sup>2</sup>	85° <sup>2</sup>	70° <sup>3</sup>	0.018	175°	175° <sup>3</sup>	10° <sup>2</sup>	0° <sup>3</sup>	10° <sup>1</sup>	5° <sup>2</sup>	0.054
85°	85° <sup>3</sup>	85° <sup>1</sup>	85° <sup>2</sup>	90° <sup>1</sup>	95° <sup>3</sup>	0.022	180°	180° <sup>3</sup>	90° <sup>2</sup>	90° <sup>1</sup>	90° <sup>3</sup>	0° <sup>1</sup>	0.032
90°	90° <sup>3</sup>	85° <sup>3</sup>	90° <sup>1</sup>	85° <sup>3</sup>	85° <sup>1</sup>	0.020							

Table 6.1.4 Similar patterns of the target 4  
using time domain feature parameter

	1st class	2nd class	3rd class	4th class	5th class	$I_d$		1st class	2nd class	3rd class	4th class	5th class	$I_d$
0°	0° <sup>4</sup>	5° <sup>4</sup>	75° <sup>1</sup>	120° <sup>4</sup>	50° <sup>3</sup>	0.443	95°	95° <sup>4</sup>	80° <sup>4</sup>	85° <sup>4</sup>	45° <sup>2</sup>	45° <sup>3</sup>	0.256
5°	5° <sup>4</sup>	175° <sup>4</sup>	60° <sup>2</sup>	60° <sup>1</sup>	70° <sup>2</sup>	0.298	100°	100° <sup>4</sup>	75° <sup>4</sup>	25° <sup>4</sup>	160° <sup>3</sup>	150° <sup>3</sup>	0.642
10°	10° <sup>4</sup>	160° <sup>4</sup>	15° <sup>4</sup>	165° <sup>4</sup>	170° <sup>4</sup>	0.321	105°	105° <sup>4</sup>	70° <sup>4</sup>	15° <sup>2</sup>	100° <sup>3</sup>	10° <sup>2</sup>	0.613
15°	15° <sup>4</sup>	10° <sup>4</sup>	160° <sup>4</sup>	5° <sup>4</sup>	165° <sup>4</sup>	0.402	110°	110° <sup>4</sup>	65° <sup>4</sup>	10° <sup>3</sup>	60° <sup>4</sup>	10° <sup>4</sup>	0.600
20°	20° <sup>4</sup>	155° <sup>4</sup>	150° <sup>4</sup>	25° <sup>4</sup>	120° <sup>4</sup>	0.510	115°	115° <sup>4</sup>	115° <sup>3</sup>	65° <sup>2</sup>	65° <sup>1</sup>	45° <sup>3</sup>	0.317
25°	25° <sup>4</sup>	145° <sup>4</sup>	150° <sup>4</sup>	65° <sup>3</sup>	30° <sup>4</sup>	0.391	120°	120° <sup>4</sup>	50° <sup>4</sup>	20° <sup>4</sup>	150° <sup>4</sup>	155° <sup>4</sup>	0.600
30°	30° <sup>4</sup>	35° <sup>4</sup>	140° <sup>4</sup>	105° <sup>3</sup>	115° <sup>3</sup>	0.508	125°	125° <sup>4</sup>	45° <sup>4</sup>	100° <sup>3</sup>	110° <sup>3</sup>	115° <sup>3</sup>	0.584
35°	30° <sup>4</sup>	35° <sup>4</sup>	140° <sup>4</sup>	105° <sup>3</sup>	115° <sup>3</sup>	0.368	130°	130° <sup>4</sup>	50° <sup>2</sup>	50° <sup>3</sup>	75° <sup>1</sup>	70° <sup>1</sup>	0.485
40°	40° <sup>4</sup>	135° <sup>4</sup>	35° <sup>4</sup>	105° <sup>4</sup>	25° <sup>4</sup>	0.498	135°	135° <sup>4</sup>	40° <sup>4</sup>	105° <sup>3</sup>	35° <sup>4</sup>	55° <sup>3</sup>	0.618
45°	45° <sup>4</sup>	125° <sup>4</sup>	110° <sup>3</sup>	100° <sup>3</sup>	100° <sup>4</sup>	0.636	140°	140° <sup>4</sup>	40° <sup>4</sup>	35° <sup>4</sup>	105° <sup>3</sup>	115° <sup>3</sup>	0.573
50°	50° <sup>4</sup>	120° <sup>4</sup>	0° <sup>4</sup>	105° <sup>3</sup>	40° <sup>4</sup>	0.526	145°	145° <sup>4</sup>	25° <sup>4</sup>	150° <sup>4</sup>	65° <sup>3</sup>	65° <sup>1</sup>	0.591
55°	55° <sup>4</sup>	50° <sup>3</sup>	75° <sup>1</sup>	60° <sup>3</sup>	75° <sup>2</sup>	0.587	150°	145° <sup>4</sup>	25° <sup>4</sup>	150° <sup>4</sup>	65° <sup>3</sup>	65° <sup>1</sup>	0.408
60°	80° <sup>1</sup>	95° <sup>3</sup>	85° <sup>1</sup>	85° <sup>2</sup>	85° <sup>3</sup>	0.019	155°	155° <sup>4</sup>	20° <sup>4</sup>	150° <sup>4</sup>	180° <sup>4</sup>	70° <sup>2</sup>	0.516
65°	65° <sup>4</sup>	10° <sup>3</sup>	110° <sup>4</sup>	60° <sup>4</sup>	15° <sup>3</sup>	0.414	160°	160° <sup>4</sup>	10° <sup>4</sup>	165° <sup>4</sup>	170° <sup>4</sup>	15° <sup>4</sup>	0.341
70°	70° <sup>4</sup>	105° <sup>4</sup>	15° <sup>2</sup>	100° <sup>3</sup>	10° <sup>2</sup>	0.461	165°	165° <sup>4</sup>	170° <sup>4</sup>	160° <sup>4</sup>	175° <sup>4</sup>	10° <sup>4</sup>	0.272
75°	75° <sup>4</sup>	30° <sup>3</sup>	160° <sup>3</sup>	25° <sup>2</sup>	25° <sup>3</sup>	0.413	170°	170° <sup>4</sup>	165° <sup>4</sup>	160° <sup>4</sup>	175° <sup>4</sup>	5° <sup>4</sup>	0.225
80°	80° <sup>4</sup>	95° <sup>4</sup>	45° <sup>3</sup>	85° <sup>4</sup>	45° <sup>2</sup>	0.324	175°	175° <sup>4</sup>	5° <sup>4</sup>	180° <sup>4</sup>	165° <sup>4</sup>	60° <sup>3</sup>	0.228
85°	95° <sup>4</sup>	85° <sup>4</sup>	45° <sup>2</sup>	40° <sup>1</sup>	45° <sup>1</sup>	0.135	180°	180° <sup>4</sup>	70° <sup>2</sup>	90° <sup>3</sup>	90° <sup>2</sup>	180° <sup>3</sup>	0.087
90°	90° <sup>4</sup>	30° <sup>2</sup>	85° <sup>4</sup>	60° <sup>1</sup>	55° <sup>1</sup>	0.421							

Table 6.1.5

가 1, 2, 3

. Reference data

가

20

Test data가 reference data

0° 90°

(specular reflection)

50%

(corner reflection)

(45°, 60°)

Table 6.1.5 The results of classification of similarly shaped targets using time domain feature parameter

		Reference Data														
		1					2					3				
		0°	15°	45°	60°	90°	0°	15°	45°	60°	90°	0°	15°	45°	60°	90°
T e s t  d a t a	1	0°	60%								20%					20%
		15°		100%												
		45°			80%									20%		
		60°				100%										
		90°					30%				70%					
	2	0°					60%					40%				
		15°		40%				60%								
		45°							100%							
		60°								80%				20%		
		90°					50%				50%					
	3	0°	20%					5%				55%	20%			
		15°							40%				60%			
		45°												100%		
		60°													100%	
		90°									40%					60%

Table 6.1.6

4

. Reference data 가 LFM 1.0ms 6 , test data  
 CW short (6 ) LFM 1.0ms (6 ) 12 .  
 (SNR)가 0 ° 45 °

Table 6.1.6 The results of aspect angle classification of target 4 using time domain feature parameter

		Reference Data													
		0 °	15 °	30 °	45 °	60 °	75 °	90 °	105 °	120 °	135 °	150 °	165 °	180 °	
T e s t  D a t a	0 °	40%				50%		10%							
	15 °	10%	40%										50%		
	30 °	10%		90%											
	45 °				50%	25%					25%				
	60 °					100%									
	75 °		20%				80%								
	90 °				20%			80%							
	105 °								100%						
	120 °									100%					
	135 °					10%					80%		10%		
	150 °											100%			
	165 °												100%		
	180 °													100%	

## 6.2

### 6.2.1 TSP

Table. 6.2.1, 6.2.2, 6.2.3 6.2.4 TSP ,  
 1, 2, 3, 4 가 가 5  
 1 50 , 2  
 40 60 , 3 55 140 , 4 45 130 . Fig.  
 6.2.1 , 가 1 90 , 2 80 ,  
 3 85 180 , 4 85 95 .

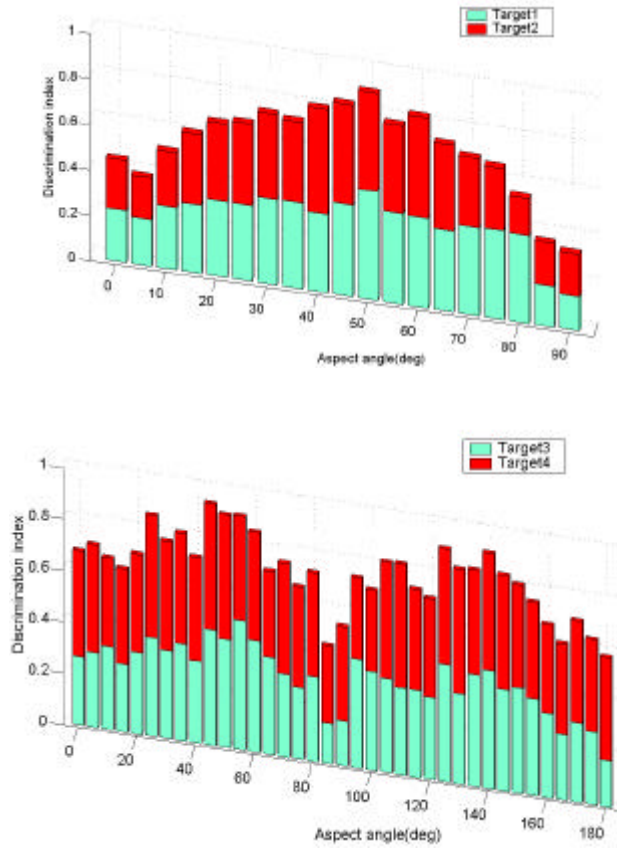

Fig. 6.2.1 The discrimination index due to frequency domain feature parameter

Table 6.2.1 Similar patterns of the target 1  
using frequency domain feature parameter

	1st class	2nd class	3rd class	4th class	5th class	$I_d$		1st class	2nd class	3rd class	4th class	5th class	$I_d$
0 °	0 ° <sup>1</sup>	0 ° <sup>2</sup>	85 ° <sup>3</sup>	90 ° <sup>1</sup>	5 ° <sup>2</sup>	0.228	50 °	50 ° <sup>1</sup>	60 ° <sup>1</sup>	50 ° <sup>2</sup>	70 ° <sup>3</sup>	40 ° <sup>1</sup>	0.480
5 °	5 ° <sup>1</sup>	0 ° <sup>3</sup>	5 ° <sup>2</sup>	0 ° <sup>2</sup>	0 ° <sup>1</sup>	0.204	55 °	55 ° <sup>1</sup>	60 ° <sup>1</sup>	85 ° <sup>4</sup>	90 ° <sup>4</sup>	30 ° <sup>2</sup>	0.400
10 °	10 ° <sup>1</sup>	5 ° <sup>2</sup>	10 ° <sup>2</sup>	0 ° <sup>3</sup>	5 ° <sup>1</sup>	0.277	60 °	60 ° <sup>1</sup>	60 ° <sup>3</sup>	90 ° <sup>4</sup>	85 ° <sup>4</sup>	60 ° <sup>2</sup>	0.395
15 °	15 ° <sup>1</sup>	15 ° <sup>2</sup>	15 ° <sup>3</sup>	10 ° <sup>2</sup>	10 ° <sup>1</sup>	0.304	65 °	65 ° <sup>1</sup>	65 ° <sup>2</sup>	65 ° <sup>3</sup>	60 ° <sup>1</sup>	70 ° <sup>1</sup>	0.355
20 °	20 ° <sup>1</sup>	20 ° <sup>2</sup>	25 ° <sup>3</sup>	15 ° <sup>1</sup>	20 ° <sup>2</sup>	0.336	70 °	70 ° <sup>1</sup>	70 ° <sup>3</sup>	50 ° <sup>2</sup>	80 ° <sup>3</sup>	65 ° <sup>4</sup>	0.388
25 °	25 ° <sup>1</sup>	25 ° <sup>2</sup>	25 ° <sup>3</sup>	15 ° <sup>2</sup>	20 ° <sup>2</sup>	0.336	75 °	75 ° <sup>1</sup>	25 ° <sup>4</sup>	50 ° <sup>3</sup>	30 ° <sup>4</sup>	70 ° <sup>1</sup>	0.391
30 °	30 ° <sup>1</sup>	30 ° <sup>3</sup>	30 ° <sup>2</sup>	35 ° <sup>2</sup>	25 ° <sup>2</sup>	0.377	80 °	80 ° <sup>1</sup>	80 ° <sup>3</sup>	55 ° <sup>4</sup>	75 ° <sup>2</sup>	75 ° <sup>1</sup>	0.387
35 °	35 ° <sup>1</sup>	35 ° <sup>2</sup>	35 ° <sup>3</sup>	45 ° <sup>1</sup>	30 ° <sup>2</sup>	0.381	85 °	85 ° <sup>1</sup>	85 ° <sup>3</sup>	90 ° <sup>2</sup>	85 ° <sup>2</sup>	90 ° <sup>3</sup>	0.181
40 °	40 ° <sup>1</sup>	40 ° <sup>3</sup>	80 ° <sup>4</sup>	45 ° <sup>1</sup>	40 ° <sup>2</sup>	0.346	90 °	90 ° <sup>1</sup>	90 ° <sup>2</sup>	90 ° <sup>3</sup>	85 ° <sup>1</sup>	85 ° <sup>2</sup>	0.152
45 °	45 ° <sup>1</sup>	35 ° <sup>2</sup>	35 ° <sup>3</sup>	35 ° <sup>1</sup>	40 ° <sup>1</sup>	0.405							

Table 6.2.2 Similar patterns of the target 2  
using frequency domain feature parameter

	1st class	2nd class	3rd class	4th class	5th class	$I_d$		1st class	2nd class	3rd class	4th class	5th class	$I_d$
0 °	0 ° <sup>2</sup>	5 ° <sup>1</sup>	0 ° <sup>1</sup>	5 ° <sup>2</sup>	0 ° <sup>3</sup>	0.220	50 °	50 ° <sup>2</sup>	70 ° <sup>1</sup>	70 ° <sup>3</sup>	40 ° <sup>4</sup>	45 ° <sup>1</sup>	0.432
5 °	5 ° <sup>2</sup>	10 ° <sup>2</sup>	10 ° <sup>1</sup>	5 ° <sup>3</sup>	0 ° <sup>3</sup>	0.184	55 °	55 ° <sup>2</sup>	75 ° <sup>1</sup>	75 ° <sup>2</sup>	40 ° <sup>4</sup>	55 ° <sup>3</sup>	0.387
10 °	10 ° <sup>2</sup>	10 ° <sup>1</sup>	5 ° <sup>2</sup>	5 ° <sup>3</sup>	0 ° <sup>3</sup>	0.240	60 °	60 ° <sup>2</sup>	60 ° <sup>3</sup>	60 ° <sup>1</sup>	65 ° <sup>3</sup>	50 ° <sup>3</sup>	0.443
15 °	15 ° <sup>2</sup>	15 ° <sup>1</sup>	10 ° <sup>1</sup>	25 ° <sup>1</sup>	10 ° <sup>2</sup>	0.308	65 °	65 ° <sup>2</sup>	65 ° <sup>1</sup>	65 ° <sup>3</sup>	30 ° <sup>2</sup>	60 ° <sup>1</sup>	0.380
20 °	20 ° <sup>2</sup>	20 ° <sup>1</sup>	20 ° <sup>3</sup>	15 ° <sup>2</sup>	25 ° <sup>1</sup>	0.340	70 °	70 ° <sup>2</sup>	70 ° <sup>3</sup>	80 ° <sup>3</sup>	80 ° <sup>1</sup>	70 ° <sup>1</sup>	0.305
25 °	25 ° <sup>2</sup>	25 ° <sup>3</sup>	25 ° <sup>1</sup>	20 ° <sup>2</sup>	30 ° <sup>2</sup>	0.357	75 °	75 ° <sup>2</sup>	75 ° <sup>3</sup>	75 ° <sup>1</sup>	70 ° <sup>2</sup>	80 ° <sup>3</sup>	0.275
30 °	30 ° <sup>2</sup>	35 ° <sup>2</sup>	30 ° <sup>1</sup>	60 ° <sup>1</sup>	30 ° <sup>3</sup>	0.374	80 °	80 ° <sup>2</sup>	60 ° <sup>2</sup>	45 ° <sup>4</sup>	55 ° <sup>4</sup>	70 ° <sup>4</sup>	0.163
35 °	35 ° <sup>2</sup>	35 ° <sup>1</sup>	35 ° <sup>3</sup>	30 ° <sup>2</sup>	45 ° <sup>1</sup>	0.354	85 °	85 ° <sup>2</sup>	85 ° <sup>1</sup>	90 ° <sup>3</sup>	90 ° <sup>1</sup>	85 ° <sup>3</sup>	0.189
40 °	40 ° <sup>2</sup>	40 ° <sup>1</sup>	40 ° <sup>3</sup>	45 ° <sup>1</sup>	35 ° <sup>3</sup>	0.462	90 °	90 ° <sup>2</sup>	90 ° <sup>1</sup>	85 ° <sup>1</sup>	90 ° <sup>3</sup>	85 ° <sup>2</sup>	0.187
45 °	45 ° <sup>2</sup>	45 ° <sup>1</sup>	80 ° <sup>3</sup>	75 ° <sup>2</sup>	80 ° <sup>2</sup>	0.438							

Table 6.2.3 Similar patterns of the target 3  
using frequency domain feature parameter

	1st class	2nd class	3rd class	4th class	5th class	$I_d$		1st class	2nd class	3rd class	4th class	5th class	$I_d$
0 °	0 ° <sup>3</sup>	5 ° <sup>1</sup>	5 ° <sup>2</sup>	0 ° <sup>2</sup>	10 ° <sup>2</sup>	0.265	95 °	95 ° <sup>3</sup>	50 ° <sup>4</sup>	80 ° <sup>3</sup>	70 ° <sup>3</sup>	55 ° <sup>4</sup>	0.424
5 °	5 ° <sup>3</sup>	10 ° <sup>2</sup>	5 ° <sup>2</sup>	10 ° <sup>3</sup>	175 ° <sup>3</sup>	0.291	100 °	100 ° <sup>3</sup>	25 ° <sup>4</sup>	75 ° <sup>3</sup>	75 ° <sup>1</sup>	100 ° <sup>4</sup>	0.384
10 °	10 ° <sup>3</sup>	5 ° <sup>3</sup>	65 ° <sup>4</sup>	100 ° <sup>4</sup>	175 ° <sup>3</sup>	0.323	105 °	105 ° <sup>3</sup>	40 ° <sup>4</sup>	50 ° <sup>2</sup>	120 ° <sup>4</sup>	135 ° <sup>4</sup>	0.366
15 °	15 ° <sup>3</sup>	15 ° <sup>1</sup>	10 ° <sup>3</sup>	15 ° <sup>2</sup>	20 ° <sup>3</sup>	0.264	110 °	110 ° <sup>3</sup>	80 ° <sup>2</sup>	75 ° <sup>3</sup>	75 ° <sup>3</sup>	80 ° <sup>3</sup>	0.338
20 °	20 ° <sup>3</sup>	20 ° <sup>1</sup>	165 ° <sup>3</sup>	20 ° <sup>2</sup>	15 ° <sup>2</sup>	0.318	115 °	115 ° <sup>3</sup>	130 ° <sup>3</sup>	75 ° <sup>1</sup>	125 ° <sup>3</sup>	65 ° <sup>3</sup>	0.338
25 °	25 ° <sup>3</sup>	25 ° <sup>2</sup>	25 ° <sup>1</sup>	75 ° <sup>4</sup>	160 ° <sup>3</sup>	0.383	120 °	120 ° <sup>3</sup>	115 ° <sup>3</sup>	110 ° <sup>3</sup>	80 ° <sup>2</sup>	55 ° <sup>2</sup>	0.321
30 °	30 ° <sup>3</sup>	30 ° <sup>1</sup>	35 ° <sup>3</sup>	30 ° <sup>2</sup>	25 ° <sup>3</sup>	0.344	125 °	125 ° <sup>3</sup>	105 ° <sup>3</sup>	65 ° <sup>1</sup>	70 ° <sup>1</sup>	55 ° <sup>3</sup>	0.457
35 °	35 ° <sup>3</sup>	35 ° <sup>1</sup>	35 ° <sup>2</sup>	45 ° <sup>1</sup>	40 ° <sup>3</sup>	0.377	130 °	130 ° <sup>3</sup>	105 ° <sup>3</sup>	35 ° <sup>4</sup>	70 ° <sup>4</sup>	70 ° <sup>3</sup>	0.351
40 °	40 ° <sup>3</sup>	40 ° <sup>1</sup>	35 ° <sup>3</sup>	45 ° <sup>1</sup>	35 ° <sup>2</sup>	0.320	135 °	135 ° <sup>3</sup>	40 ° <sup>1</sup>	140 ° <sup>3</sup>	45 ° <sup>1</sup>	50 ° <sup>1</sup>	0.433
45 °	45 ° <sup>3</sup>	150 ° <sup>3</sup>	70 ° <sup>4</sup>	75 ° <sup>4</sup>	45 ° <sup>1</sup>	0.449	140 °	140 ° <sup>3</sup>	50 ° <sup>1</sup>	40 ° <sup>1</sup>	135 ° <sup>3</sup>	55 ° <sup>3</sup>	0.458
50 °	50 ° <sup>3</sup>	75 ° <sup>1</sup>	70 ° <sup>3</sup>	70 ° <sup>1</sup>	50 ° <sup>2</sup>	0.420	145 °	145 ° <sup>3</sup>	30 ° <sup>1</sup>	155 ° <sup>3</sup>	30 ° <sup>3</sup>	150 ° <sup>3</sup>	0.395
55 °	55 ° <sup>3</sup>	125 ° <sup>3</sup>	75c <sup>1</sup>	110 ° <sup>4</sup>	65 ° <sup>2</sup>	0.504	150 °	150 ° <sup>3</sup>	35 ° <sup>3</sup>	30 ° <sup>1</sup>	40 ° <sup>3</sup>	30 ° <sup>2</sup>	0.409
60 °	60 ° <sup>3</sup>	60 ° <sup>1</sup>	60 ° <sup>2</sup>	170 ° <sup>4</sup>	115 ° <sup>4</sup>	0.434	155 °	155 ° <sup>3</sup>	25 ° <sup>2</sup>	25 ° <sup>3</sup>	160 ° <sup>3</sup>	25 ° <sup>1</sup>	0.377
65 °	65 ° <sup>3</sup>	60 ° <sup>2</sup>	65 ° <sup>1</sup>	65 ° <sup>2</sup>	125 ° <sup>4</sup>	0.377	160 °	160 ° <sup>3</sup>	25 ° <sup>1</sup>	165 ° <sup>3</sup>	15 ° <sup>2</sup>	75 ° <sup>4</sup>	0.329
70 °	70 ° <sup>3</sup>	70 ° <sup>1</sup>	80 ° <sup>3</sup>	50 ° <sup>2</sup>	90 ° <sup>1</sup>	0.321	165 °	165 ° <sup>3</sup>	20 ° <sup>2</sup>	20 ° <sup>1</sup>	160 ° <sup>3</sup>	20 ° <sup>3</sup>	0.256
75 °	75 ° <sup>3</sup>	75 ° <sup>2</sup>	80 ° <sup>3</sup>	115 ° <sup>3</sup>	80 ° <sup>3</sup>	0.277	170 °	170 ° <sup>3</sup>	165 ° <sup>3</sup>	15 ° <sup>2</sup>	20 ° <sup>1</sup>	15 ° <sup>3</sup>	0.309
80 °	80 ° <sup>3</sup>	70 ° <sup>3</sup>	90 ° <sup>3</sup>	100 ° <sup>3</sup>	90 ° <sup>1</sup>	0.330	175 °	175 ° <sup>3</sup>	10 ° <sup>2</sup>	5 ° <sup>3</sup>	10 ° <sup>1</sup>	0 ° <sup>2</sup>	0.283
85 °	85 ° <sup>3</sup>	85 ° <sup>1</sup>	180 ° <sup>3</sup>	90 ° <sup>1</sup>	90 ° <sup>2</sup>	0.158	180 °	180 ° <sup>3</sup>	85 ° <sup>3</sup>	90 ° <sup>1</sup>	85 ° <sup>1</sup>	90 ° <sup>2</sup>	0.182
90 °	90 ° <sup>3</sup>	85 ° <sup>2</sup>	85 ° <sup>1</sup>	90 ° <sup>1</sup>	90 ° <sup>2</sup>	0.175							



Table 6.2.4 Similar patterns of the target 4  
using frequency domain feature parameter

	1st class	2nd class	3rd class	4th class	5th class	$I_d$		1st class	2nd class	3rd class	4th class	5th class	$I_d$
0°	0° <sup>4</sup>	30° <sup>4</sup>	135° <sup>4</sup>	35° <sup>4</sup>	10° <sup>4</sup>	0.411	95°	95° <sup>4</sup>	85° <sup>4</sup>	90° <sup>4</sup>	85° <sup>1</sup>	85° <sup>2</sup>	0.315
5°	5° <sup>4</sup>	10° <sup>4</sup>	5° <sup>2</sup>	15° <sup>4</sup>	10° <sup>1</sup>	0.419	100°	100° <sup>4</sup>	65° <sup>4</sup>	105° <sup>4</sup>	10° <sup>3</sup>	5° <sup>3</sup>	0.318
10°	10° <sup>4</sup>	165° <sup>4</sup>	5° <sup>4</sup>	15° <sup>4</sup>	170° <sup>4</sup>	0.344	105°	105° <sup>4</sup>	100° <sup>4</sup>	65° <sup>4</sup>	120° <sup>4</sup>	45° <sup>3</sup>	0.452
15°	15° <sup>4</sup>	10° <sup>4</sup>	165° <sup>4</sup>	20° <sup>4</sup>	175° <sup>4</sup>	0.369	110°	110° <sup>4</sup>	120° <sup>4</sup>	75° <sup>1</sup>	30° <sup>4</sup>	55° <sup>4</sup>	0.481
20°	20° <sup>4</sup>	155° <sup>4</sup>	150° <sup>4</sup>	15° <sup>4</sup>	165° <sup>4</sup>	0.380	115°	115° <sup>4</sup>	50° <sup>2</sup>	65° <sup>4</sup>	70° <sup>1</sup>	145° <sup>4</sup>	0.393
25°	25° <sup>4</sup>	145° <sup>4</sup>	30° <sup>4</sup>	100° <sup>3</sup>	75° <sup>1</sup>	0.476	120°	120° <sup>4</sup>	60° <sup>4</sup>	65° <sup>4</sup>	100° <sup>4</sup>	105° <sup>4</sup>	0.382
30°	30° <sup>4</sup>	0° <sup>4</sup>	135° <sup>4</sup>	25° <sup>4</sup>	145° <sup>4</sup>	0.423	125°	125° <sup>4</sup>	20° <sup>4</sup>	65° <sup>3</sup>	100° <sup>3</sup>	60° <sup>4</sup>	0.448
35°	35° <sup>4</sup>	0° <sup>4</sup>	30° <sup>4</sup>	40° <sup>4</sup>	10° <sup>4</sup>	0.430	130°	130° <sup>4</sup>	70° <sup>3</sup>	60° <sup>3</sup>	165° <sup>4</sup>	70° <sup>1</sup>	0.484
40°	40° <sup>4</sup>	105° <sup>3</sup>	50° <sup>2</sup>	70° <sup>3</sup>	35° <sup>4</sup>	0.402	135°	135° <sup>4</sup>	0° <sup>4</sup>	30° <sup>4</sup>	140° <sup>4</sup>	50° <sup>2</sup>	0.407
45°	45° <sup>4</sup>	50° <sup>2</sup>	110° <sup>4</sup>	120° <sup>4</sup>	30° <sup>4</sup>	0.489	140°	140° <sup>4</sup>	135° <sup>4</sup>	115° <sup>4</sup>	30° <sup>3</sup>	150° <sup>4</sup>	0.456
50°	50° <sup>4</sup>	95° <sup>3</sup>	80° <sup>3</sup>	70° <sup>4</sup>	95° <sup>4</sup>	0.484	145°	145° <sup>4</sup>	25° <sup>4</sup>	30° <sup>4</sup>	115° <sup>4</sup>	150° <sup>4</sup>	0.442
55°	55° <sup>4</sup>	110° <sup>4</sup>	75° <sup>1</sup>	95° <sup>3</sup>	50° <sup>3</sup>	0.405	150°	150° <sup>4</sup>	20° <sup>4</sup>	155° <sup>4</sup>	50° <sup>2</sup>	145° <sup>4</sup>	0.400
60°	60° <sup>4</sup>	120° <sup>4</sup>	90° <sup>2</sup>	100° <sup>4</sup>	65° <sup>4</sup>	0.422	155°	155° <sup>4</sup>	20° <sup>4</sup>	160° <sup>4</sup>	175° <sup>4</sup>	180° <sup>4</sup>	0.375
65°	65° <sup>4</sup>	100° <sup>4</sup>	10° <sup>3</sup>	120° <sup>4</sup>	115° <sup>4</sup>	0.335	160°	160° <sup>4</sup>	175° <sup>4</sup>	155° <sup>4</sup>	165° <sup>4</sup>	180° <sup>4</sup>	0.343
70°	70° <sup>4</sup>	75° <sup>4</sup>	70° <sup>3</sup>	100° <sup>4</sup>	15° <sup>2</sup>	0.431	165°	165° <sup>4</sup>	10° <sup>4</sup>	160° <sup>4</sup>	170° <sup>4</sup>	15° <sup>4</sup>	0.350
75°	75° <sup>4</sup>	85° <sup>4</sup>	70° <sup>4</sup>	80° <sup>4</sup>	95° <sup>4</sup>	0.392	170°	170° <sup>4</sup>	175° <sup>4</sup>	165° <sup>4</sup>	10° <sup>4</sup>	15° <sup>4</sup>	0.396
80°	80° <sup>4</sup>	40° <sup>1</sup>	75° <sup>4</sup>	85° <sup>4</sup>	30° <sup>2</sup>	0.403	175°	175° <sup>4</sup>	180° <sup>4</sup>	160° <sup>4</sup>	170° <sup>4</sup>	155° <sup>4</sup>	0.359
85°	85° <sup>4</sup>	95° <sup>4</sup>	90° <sup>4</sup>	85° <sup>1</sup>	90° <sup>2</sup>	0.300	180°	180° <sup>4</sup>	175° <sup>4</sup>	155° <sup>4</sup>	160° <sup>4</sup>	90° <sup>1</sup>	0.398
90°	90° <sup>4</sup>	85° <sup>4</sup>	95° <sup>4</sup>	60° <sup>1</sup>	30° <sup>2</sup>	0.365							

Table 6.2.5 TSP

1, 2, 3

가 , 50%

Table 6.2.5 The results of classification of similarly shaped targets using frequency domain feature parameter

		Reference Data														
		1					2					3				
		0 °	15 °	45 °	60 °	90 °	0 °	15 °	45 °	60 °	90 °	0 °	15 °	45 °	60 °	90 °
T e s t  d a t a	1	0 °	75%			20%	5%									
		15 °		100%												
		45 °			100%											
		60 °				100%										
		90 °					80%				5%					15%
	2	0 °	5%				55%					40%				
		15 °		40%				60%								
		45 °			50%				50%							
		60 °				10%				80%					20%	
		90 °					45%				50%					5%
	3	0 °										100%				
		15 °			20%				20%				60%			
		45 °												100%		
		60 °				5%				15%					80%	
		90 °					20%				30%					50%

Table 6.2.6 12 test data

4

50%

75

105

45%

Table 6.2.6 The results of aspect angle classification of target 4 using frequency domain feature parameter

		Reference Data												
		0 °	15 °	30 °	45 °	60 °	75 °	90 °	105 °	120 °	135 °	150 °	165 °	180 °
<b>T</b>	0 °	100%												
	15 °		80%										5%	
	30 °	45%		55%										
	45 °			5%	55%	10%			5%	20%	5%			
	60 °					80%			20%					
	75 °						50%	5%	45%					
	90 °							100%						
	105 °							20%	40%	40%				
	120 °		10%						20%	70%				
<b>D</b>	135 °							15%		85%				
	150 °										100%			
	165 °											100%		
	180 °												35%	65%

### 6.3 -

Table. 6.3.1 - 4

가 5  
reference data , 60 125 가  
가  
50 45 , 40 , 85 , 90 , 90 50 , 80 , 70 ,  
75 , 95 40 , 45 , 85 , 100 , 100  
85 , 95 , 40 , 90 가 .

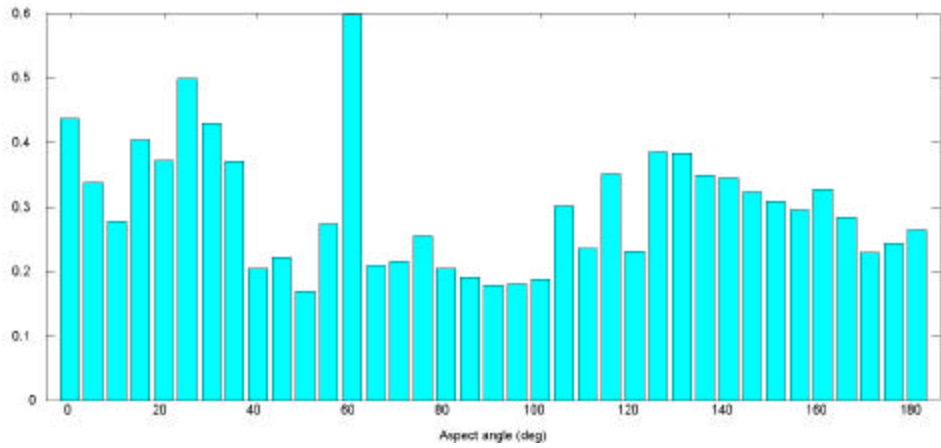

Fig. 6.3.1 The discrimination index due to time-frequency domain feature parameter

Table 6.3.1 The results of aspect angle classification of target 4

using time-frequency domain feature parameter

Aspect angle( ° )	1st class	2nd class	3rd class	4th class	5th class		Aspect angle( ° )	1st class	2nd class	3rd class	4th class	5th class	
0	0 °	5 °	10 °	15 °	0 °	0.437	95	95 °	40 °	45 °	85 °	100 °	0.181
5	5 °	0 °	10 °	15 °	175 °	0.338	100	100 °	85 °	95 °	40 °	90 °	0.189
10	10 °	15 °	20 °	5 °	0 °	0.278	105	105 °	100 °	85 °	80 °	95 °	0.302
15	15 °	10 °	5 °	0 °	180 °	0.404	110	110 °	120 °	80 °	65 °	70 °	0.237
20	20 °	10 °	175 °	170 °	15 °	0.373	115	115 °	120 °	110 °	65 °	55 °	0.352
25	25 °	135 °	30 °	10 °	155 °	0.500	120	120 °	110 °	65 °	70 °	115 °	0.232
30	30 °	35 °	25 °	10 °	20 °	0.430	125	125 °	130 °	55 °	120 °	115 °	0.386
35	35 °	30 °	40 °	45 °	55 °	0.372	130	130 °	125 °	55 °	135 °	140 °	0.384
40	40 °	45 °	95 °	85 °	100 °	0.205	135	135 °	0 °	5 °	25 °	10 °	0.350
45	45 °	40 °	95 °	85 °	100 °	0.223	140	140 °	145 °	150 °	130 °	70 °	0.340
50	50 °	45 °	40 °	85 °	90 °	0.170	145	145 °	140 °	150 °	155 °	70 °	0.324
55	55 °	120 °	65 °	130 °	50 °	0.274	150	150 °	155 °	145 °	140 °	165 °	0.309
60	60 °	55 °	120 °	135 °	125 °	0.598	155	155 °	150 °	165 °	160 °	145 °	0.296
65	65 °	70 °	120 °	110 °	50 °	0.211	160	160 °	165 °	170 °	155 °	175 °	0.328
70	70 °	75 °	65 °	80 °	110 °	0.217	165	165 °	170 °	160 °	175 °	180 °	0.284
75	75 °	70 °	50 °	80 °	110 °	0.256	170	170 °	175 °	180 °	165 °	160 °	0.230
80	80 °	90 °	110 °	70 °	50 °	0.205	175	175 °	170 °	180 °	165 °	160 °	0.245
85	85 °	100 °	90 °	80 °	95 °	0.192	180	180 °	170 °	175 °	165 °	160 °	0.265
90	90 °	50 °	80 °	70 °	75 °	0.179							

7.

가 가

TSP FFT

FFT TSP

STFT

가

가

(neural network)

가

[1][13].

가

- [1] Anders Svardström, “Neural network feature vectors for sonar targets classification,” *J. Acoust. Soc. Am.* **93**(5), pp. 2656-2665, May 1993
- [2] Scot F. Morse et al., “High-frequency backscattering enhancements by thick finite cylindrical shells in water at oblique incidence: Experiments, interpretation, and calculations,” *J. Acoust. Soc. Am.* **103**(2), pp. 785-794, February 1998
- [3] Richard A. Altes, “Detection, estimation, and classification with spectrograms,” *J. Acoust. Soc. Am.* **67**(4), pp. 1232-1246, April 1980
- [4] Christophe Journeau, “High-frequency vibrations of liquid-filled thick elastic cylindrical shells: A simplified modal approach,” *J. Acoust. Soc. Am.* **97**(3), pp. 1670-1677, March 1995
- [5] , , “ - ,” , **12** 4 , pp. 92-100, 1998. 11
- [6] Martin D.W. et al., “An automatic target recognition algorithm using time domain features,” *Animal Sonar: Process and Performance*, New York: Plenum Press, pp. 829-833, 1993
- [7] Harvey F. Silverman, “A Comparison of Several Speech-Spectra Classification Methods,” *IEEE Trans. on ASSP*, Vol. ASSP-**24**, NO.4, pp. 289-295, Aug. 1976
- [8] Guillermo C. Gaunaud, Donald Brill, and Hanson Huang, “Signal processing of the echo signatures returned by submerged shells insonified by dolphin ‘clicks’: Active classification,” *J. Acoust. Soc. Am.* **103**(3), pp. 1547-1556, March 1998
- [9] Paul Chestnut, Helen Landsman, and Robert W. Floyd, “A sonar target recognition experiment,” *J. Acoust. Soc. Am.* **66**(1), pp. 140-147, July 1979
- [10] Whitlow W.L. Au, *The Sonar of Dolphins*, Springer-Verlag, pp. 66-74, 1993

- [11] Whitlow W.L. Au and Charles W. Turl, "Material composition discrimination of cylinders at different aspect angles by an echolocating Dolphin," J. Acoust. Soc. Am. **89**(5), pp. 2448-2451, May 1991
- [12] Linda V. Martin Traykovski et al, "Model-Based Covariance Mean Variance Classification Techniques: Algorithm Development and Application to the Acoustic Classification of Zooplankton," IEEE J. of Oceanic Eng. Vol.**23**, No.4, pp. 344-365, October 1998
- [13] Amlan Kundu, "Transient sonar signal classification using hidden Markov models and neural nets," IEEE J. of Oceanic Eng. Vol.**19**, pp. 87-99, January 1994
- [14] D. E. Nelson, "A Statistical Scattering Model for Time-Spread SONAR Targets," Ph.D. Dissertation, Dept. of Electrical Eng., Univ. of Rochester, New York, 1975
- [15] Nai-chyuan Yen et al., "Time-frequency analysis of acoustic scattering from elastic objects," J. Acoust. Soc. Am. **87**(6), pp. 2359-2370, June 1990
- [16] Augustine H. Gray, JR., "Distance Measures for Speech Processing," IEEE Trans. on ASSP, Vol. ASSP-**24**, NO.5, pp. 380-391, October 1976
- [17] Whitlow W.L. Au and Douglas W. Martin, "Insights into dolphin sonar discrimination capabilities from human listening experiments," J. Acoust. Soc. Am. **86**(5), pp.1662-1670, November 1989
- [18] Robert J. Urick, *Principles of Underwater Sound*, McGraw-Hill Book Company, 3rd Edition, pp. 317-325, 1983
- [19] William S. Burdic, *Underwater Acoustic System Analysis*, Prentice Hall, 2nd Edition, pp. 187-189, 1991
- [20] , , 正益社, pp. 16-61, 1991



• • •

## 歸 天

:

가 .

,

가 .

가 ,

가 .

,

가 , .....  
.....

“ ..... ”  
.....

가 .

"Man is not made for defeat." "A man can be destroyed but not defeated." *'The Old Man and the Sea'* .

가

The deepest definition of youth is life as yet untouched by tragedy.