

KINEMATIC ANALYSIS OF QUICK-RETURN MECHANISM IN THREE VARIOUS APPROACHES

Katarína Monková, Peter Monka, Sergej Hloch, Jan Valíček

Professional paper

The article deals with kinematic analysis of quick-return mechanism that is executed by three various methods. The modern methods are computer aided with the special software for analysis processing, which can simulate not only the motion of the mechanism, but can define the position, velocity, acceleration, forces, moments and other parameters at every moment of time, but verification and mechanics laws understanding are necessary. The goal of the kinematic analysis is to investigate the motion of individual components of mechanism (or its important points) in dependence on the motion of drivers. The article describes the basic principles of three approaches, as well as the advantages and disadvantages of presented solutions. The obtained results can be compared, if the same input parameters are used.

Keywords: *acceleration, computer aided solution, kinematic analysis, mechanism, numerical solution, position, speed*

Kinematička analiza Whitwordovog mehanizma u tri različita pristupa

Stručni članak

Članak se bavi kinematičkom analizom Whitwordovog mehanizma koja je izvedena u tri različite metode. Suvremene metode su računalno potpomognute s posebnim softverom za analizu obrade, koji može simulirati ne samo gibanje mehanizma, već može odrediti i položaj, brzinu, ubrzanje, sile, momente te druge parametre u svakom trenutku vremena, ali je potrebna provjera i razumijevanje zakona mehanike. Cilj je kinematičke analize istražiti gibanje pojedinih komponenti mehanizma (ili njegovih važnih točaka) u ovisnosti o gibanju pobuđivača. Ovdje su opisani osnovni principi triju pristupa te prednosti i nedostaci prezentiranih rješenja. Dobiveni se rezultati mogu usporediti, ako su rabljeni isti ulazni parametri.

Ključne riječi: *brzina, kinematička analiza, mehanizam, numeričko rješavanje, položaj, računalno potpomognuto rješenje, ubrzanje*

1

Introduction

Uvod

Mechanisms have become a part of our life and are to be found not only in technical practice, but along every step of our everyday life [1, 2, 6]. They help us to do our work more easily and more comfortably.

The mechanism is usually a part of a machine where two or more pieces are combined, so that the motion of the first compels the motion of the others, according to a law depending on the nature of the combination. The operation of any machine depends upon two things:

1. the transmission of certain forces,
2. the production of determinate motions.

In designing, due consideration must be given to both of these, so that each part may be adapted to bear the stresses imposed on it, as well as have the proper motion relative to the other parts of the machine.

The structure that supports the moving parts and regulates the path motions, or kind of motion, is called the frame of a machine [3]. In discussing the motions of the moving parts, they are considered in regard to the frame. The frame absorbs the forces or moments that originate at the transformation of motions [7]. The components which actuate the mechanism are called the drivers, the other components whose motions are caused are called the followers.

It is often needed to define the velocity and acceleration of a rigid body or some point of mechanism in manufacturing practice, if the input parameters of driver are known. The kinematic analysis is concerned with the problems listed below.

The goal of the kinematic analysis is to investigate the motion of individual components of a mechanism (or its chosen points) in dependence on the motion of drivers. To

investigate the motion means to determine the dependency of the position, velocity and acceleration of examined members and important points on the motion of driven members or on the time.

Although all real machines must exist in three-dimensional space, there is a very important class of motions in terms of which the action of most human-made machines can be analyzed. This class of motions is known as planar or two-dimensional motion, and the machines to which it applies are known as planar machines or planar mechanisms. The planar motion is the motion in which all points in the system are assumed to move so that the distance from each point in the system to some reference plane remains constant. That is, all displacements in planar motion are parallel to that plane, and they can be represented by their projections onto that plane. [9]

2

Kinematic analysis approaches and problem solution

Pristupi kinematičke analize i rješenje problema

The comparison of the numerical, graphical and computer aided solution of kinematic analysis was realized on the planar quick-return mechanism that is usually used as the base for shaping machine in technical practice.

To present the mechanism of motion behaviour to students studying at the Faculty of Manufacturing Technologies of Technical University in Košice with the seat in Prešov, in Slovakia, five times reduced physical model of the mechanism was prepared (on the basis of real mechanism) as shown in Fig. 1.

A simple representation of real mechanism that serves as the basis for the next processing is the kinematic scheme.

The kinematic scheme of a quick-return mechanism, drawn up on the basis of real mechanism, is shown in Fig. 2. Individual components of the mechanism in this scheme are numbered due to the next solution limpidity.

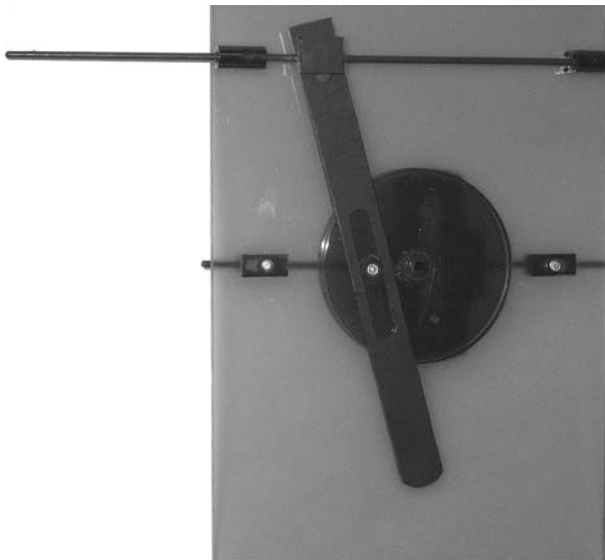

Figure 1 Physical model of reduced mechanism
Slika 1. Fizički model smanjenog mehanizma

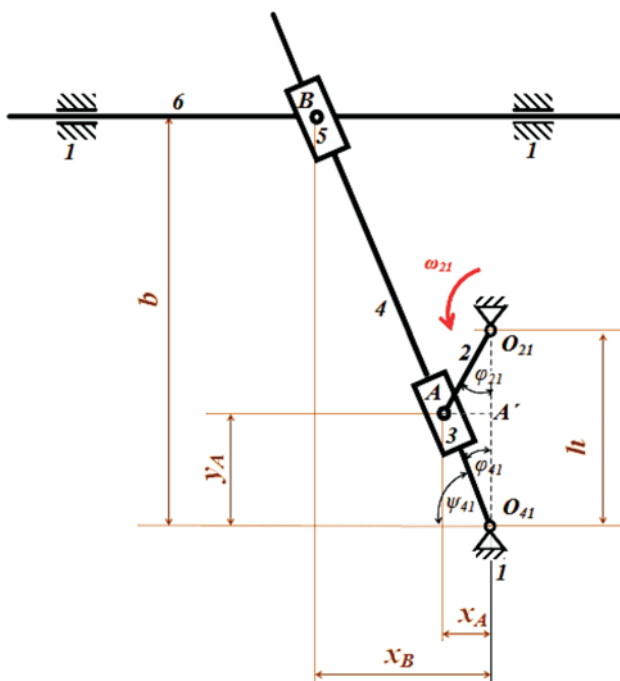

Figure 2 Kinematic scheme of mechanism
Slika 2. Kinematička shema mehanizma

The input values of the studied mechanism, shown in Fig. 1 and Fig. 2, are:

$$\begin{aligned} h &= 360 \text{ mm} \\ b &= 570 \text{ mm} \\ r &= 135 \text{ mm} \\ \varphi_{21} &= 30^\circ \\ \omega_{21} &= 1,745 \text{ rad/s.} \end{aligned}$$

The frame is numbered by number 1; the driver is the crank with number 2 that rotates at constant angular speed ω_{21} .

The goal of the kinematic analysis of this mechanism is to define the motion of the component 6 whose all points describe the line path. At the end of the bar number 6 can be located a tool for machining. The kinematic analysis can be done in several ways, such as: analytical solution, graphical solution, and computer aided solution.

2.1 Analytical solution Analitičko rješenje

There are several types of *analytical solution* that is usually focused on the task of the solution position. Most often the numerical method uses the trigonometric rules and mathematical definitions such as functions, differentiation, equations, etc. The advantages of this method include minimal cost for its realization and the possibility to use the table applications for obtaining mathematical function through out-put values.

The disadvantages of this method are:

- the expression of mathematical equations is time consuming,
- it requires an excellent mathematical knowledge of the operator,
- this method does not solve the collisions of components.

For analytical solution the coordinate system of mechanism is located into the point O_{41} , the position of the important points is described by their x and y coordinates. The parameter that changes with time t is the angle $\varphi_{21(t)}$. Kinematic dependency of φ_{21} on time if ω_{21} is constant, can be expressed:

$$\begin{aligned} \omega_{21} &= \frac{d\varphi}{dt}, \\ d\varphi &= \omega_{21} \cdot dt, \\ \int_0^{\varphi_{21}} d\varphi &= \omega_{21} \cdot \int_0^t dt, \\ \varphi_{21} &= \omega_{21} \cdot t. \end{aligned} \quad (1)$$

The dependency of the x -coordinate of point B on the angle $\varphi_{21(t)}$ is defined by trigonometric method. The position of point B is given by:

$$\begin{aligned} x_B &= \frac{b}{\tan \psi_{41}}, \\ x_B &= \frac{b}{\tan(90^\circ - \varphi_{41})} = \frac{b}{\cotan \varphi_{41}} = \frac{b}{\frac{1}{\tan \varphi_{41}}} = b \cdot \tan \varphi_{41}, \\ \tan \varphi_{41} &= \frac{\overline{A'A}}{\overline{A'O_{41}}} = \frac{r \cdot \sin \varphi_{21}}{h - r \cdot \cos \varphi_{21}}, \\ x_B &= b \cdot \frac{r \cdot \sin(\omega_{21} \cdot t)}{h - r \cdot \cos(\omega_{21} \cdot t)}. \end{aligned} \quad (2)$$

Velocity of the point B is simultaneously the velocity of the whole body 6 and it can be expressed by relation:

$$\begin{aligned} v_{xB} &= v_B = \frac{dx_B}{dt} = \dot{x}_B, \\ \dot{x}_B &= b \cdot \frac{r \cdot \omega_{21} \cdot [h \cdot \cos(\omega_{21} \cdot t) - r \cdot \cos^2(\omega_{21} \cdot t) - r \cdot \sin^2(\omega_{21} \cdot t)]}{[h - r \cdot \cos(\omega_{21} \cdot t)]^2}, \\ \dot{x}_B &= b \cdot \frac{r \cdot \omega_{21} \cdot [h \cdot \cos(\omega_{21} \cdot t) - r]}{[h - r \cdot \cos(\omega_{21} \cdot t)]^2}. \end{aligned} \quad (3)$$

The final equation for a_B in regard to the frame is:

$$a_{xB} = a_B = \frac{dv_B}{dt} = \dot{v}_B = \ddot{x}_B,$$

$$\dot{x}_B = -b \cdot r \cdot \omega_{21}^2 \cdot \sin(\omega_{21} \cdot t) \cdot C,$$

$$C = \frac{h \cdot [h - r \cdot \cos(\omega_{21} \cdot t)] + 2r \cdot [h \cdot \cos(\omega_{21} \cdot t) - r]}{[h - r \cdot \cos(\omega_{21} \cdot t)]^3}. \quad (4)$$

The results achieved after substitution of concrete value 30° to parameter φ_{21} in the equations (3) and (4) $v_B = 0,40169$ m/s, $a_B = 1,10303$ m/s².

2.2 Graphical solution

Grafičko rješenje

Graphical solution is suitable only for the solving of planar mechanism and proceeds from the kinematic scheme of mechanism sketched in the selected scale with the scaled input parameters (velocity, acceleration) in vector form. The advantages of this method are:

- minimal cost for its realization,
- possibility to use graphical software,
- relatively quick solution of obtaining output values for one concrete combination of defined input parameters.

The disadvantages are:

- for every change of input value it is necessary to process a new graphical solution,
- inaccuracy,
- it does not solve the collisions of components.

This solution consists of investigation of velocity and acceleration field of important mechanism points. It provides information about kinematic parameters for a concrete time moment, which means it provides information on the values corresponding to the concrete immediate mechanism position.

Graphical solution is suitable for investigation of planar mechanism. This method uses vectors and the principles of operating with them, it is based on the application of simultaneous motion theory and the knowledge of kinematics. Input parameters are drawn in the needed scale, of course it influences the output values which have to be changed after solution according to the scale.

The example of graphical solution of wing mechanism is shown in Fig. 3.

2.3 Computer aided solution

Računalno potpomognuto rješenje

Computer aided solution uses a special software designed for it. Today there are very interactive and user friendly 3D softwares in the market, which can simulate not only the motion of the mechanism, but they can define the position, velocity, acceleration, forces, moments and other parameters at every moment of time in a graph or vector version. Inside the computer application it is necessary primarily to create the 3D models of individual components of mechanism, secondary to join them by kinematic linkage which removes needed number of the degree of freedom.

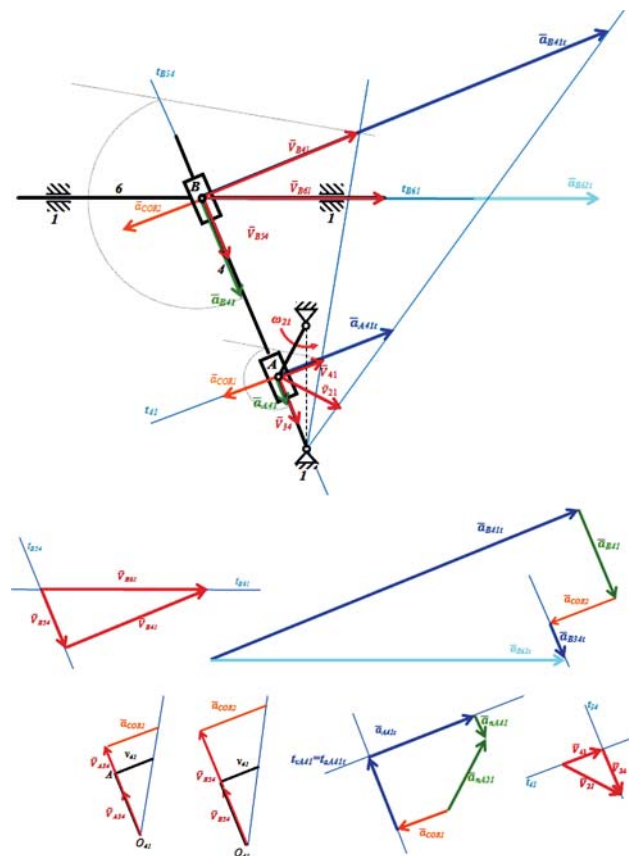

Figure 3 The graphical solution
Slika 3. Grafičko rješenje

The degree of approximation to the real situation is higher at the more difficult systems than at the simpler software, which increases the demands for hardware. Therefore it is important to choose the simulation tool correctly so as not to over-price the manufacturing, but so that the achieved results accordingly correspond to the specified conditions on the other hand. This approach requires not only the software control, but it demands the knowledge of the mechanics field, too.

The advantages of this method are:

- visualisation of the mechanism motion in virtual environment with its details,
- fast data processing and fast output data acquirement for variable combination of input values,
- possibility to use the output data for other applications,
- the material characteristics definition and consequently the possibility of dynamic [5] characteristics generation,
- the chance for direct transmission to dynamic analysis,
- the ability of components impact determination in virtual background.

The disadvantages are:

- expensive software and hardware equipment,
- necessity for the operator to be able to work with the equipment (software, hardware).

The virtual model of wing mechanism shown in Fig. 4 was created by software Pro/Engineer on the basis of kinematic scheme (Fig. 2).

The software includes the simulation tools of Pro/Engineer, which are suitable for the analysis and the control rationalization of complicated processes. It provides the engineers within the product development process to

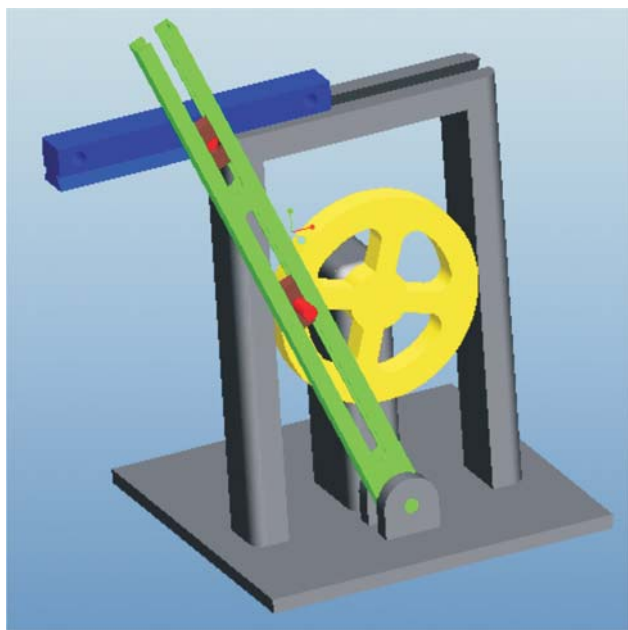

Figure 4. Virtual model of mechanism
Slika 4. Virtualni model mehanizma

perform the kinematic motion simulation and behavioural insight into the assembly through easy definition and animation of connections, such as pin joints, ball joints, sliders and other. These connections and the resulting assembly constraints facilitate the assembly of closed loop systems. They can be used compatibly and in combination with packaging and traditional like mate, align insert, offset and so on.

Once the mechanism is assembled, engineers can observe how their mechanism designs will behave geometrically through interactive part dragging and user-defined motion simulations. Any point on a mechanism assembly can be dragged interactively by the user to animate the mechanism. Predefined motion simulations, using drivers to simulate motors or actuators, also provide animation. There is a powerful design tool enabling engineers to create industry-best mechanism designs by clearly building and communicating "design intent" into mechanism assemblies and subassemblies in this software.

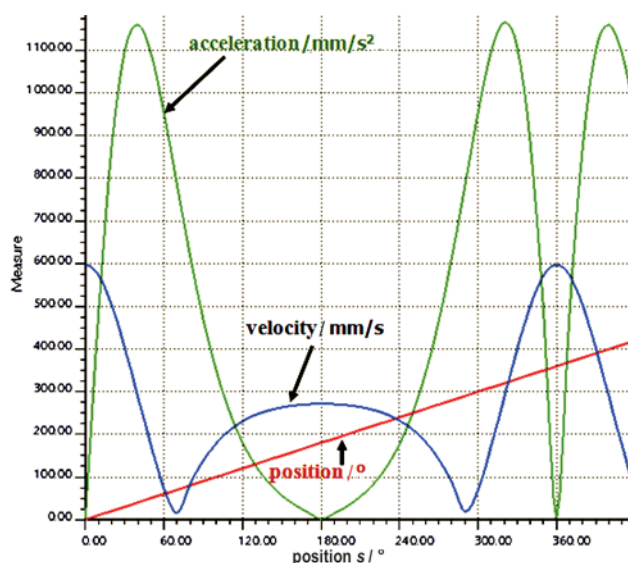

Figure 5. Output data of kinematic analysis in graph form
Slika 5. Izlazni podaci kinematičke analize u grafičkom obliku

After the modelling mechanism, joints and input parameter definition, it is possible to provide the kinematic analysis. Output data can be designed direct in CAD/CAM system Pro/Engineer as graphs (Fig. 5) or as vectors (Fig. 6) or it can be sent to the other software for the next processing.

The red line in Fig. 5 represents the position of component 2 as input parameter φ_{21} measured in degrees ($^{\circ}$), the blue curve of graph shows the velocity profile (mm/s) of the bar 6, and the green curve describes the acceleration profile (mm/s²) of the output slider 6, after analysis has been executed.

For example it is possible to determine the maximum value of acceleration on the basis of the graph, which is achieved in two positions $\varphi_{21}=45^{\circ}$ and $\varphi_{21}=315^{\circ}$.

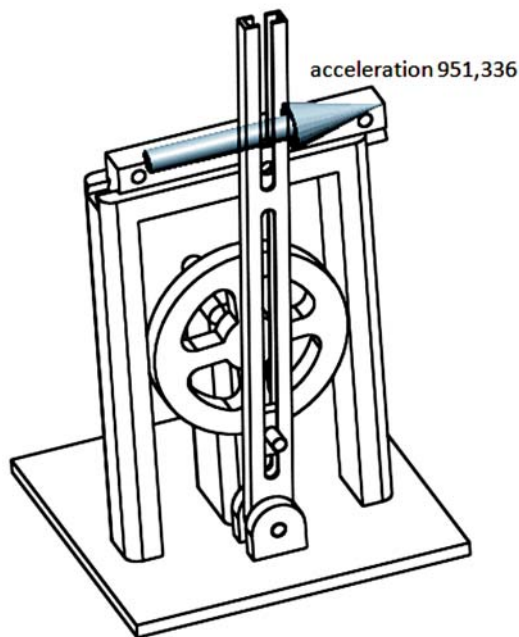

Figure 6. Output data of kinematic analysis in vector form
Slika 6. Izlazni podaci kinematičke analize u vektorskom obliku

The vector shown in Fig. 6 represents the kinematic parameter in actual position; in this case it is the acceleration. The advantage of vector representation is the possibility to obtain not only the value of kinematic parameter, but its orientation, too.

The values obtained by all approaches of kinematic analysis are presented in Tab. 1. The value for the comparison of all types of solutions, numerical, graphical and computer aided, was done for the concrete position of crank 2 at $\varphi_{21}=30^{\circ}$.

Table 1. Obtained kinematic values
Tablica 1. Dobivene kinematičke vrijednosti

Kinematic analysis – p ^o int B		Meth ^o ds		
		Analytical	C ^o mputer aided	Graphical
Values f ^o r $\varphi_{21}=30^{\circ}$				
Speed	v_B /m/s	0,40269	0,402951	0,40
Accelerati ^o n	a_B /m/s ²	1,10303	1,09970	1,10

It can be said that the results are the same and so the final decision about which of the methods will be selected depends only on investigators and their possibilities. If they are good in math, they can choose the numerical method; if they have hardware and software for kinematic analysis at their disposal, they can use the computer aided method. In all three cases they have to know the basic principles of mechanics.

3

Conclusion

Zaključak

The design of a machine or a mechanism or any moving mechanical system always starts with a consideration of kinematics because kinematics is the study of the geometry of motion. That is, kinematics deals with the functional relationships between the parts interconnected, and how those parts move relative to each other. Only after choices have been made regarding those three factors can matters such as strengths, materials, fabrication techniques, and costs be seriously addressed. Failure to devote the proper attention to kinematics "up front" can, and often does, result in the design of a system with substandard or nonoptimum performance and/or with unsatisfactory reliability. [9, 4]

Fortunately, today, the availability of very powerful personal computers and the associated software allows kinematic synthesis and analysis, which were formerly laborious, to be performed quickly and cheaply. There is no longer an excuse for avoiding doing careful kinematic design up front. Because of the availability of these computer aids and the consequent incentives to apply kinematic principles in design, it is becoming increasingly important for the practicing engineer to have a good understanding of those kinematic principles.

Actually before engineers can start to use a computer for synthesis or analysis of a machine, they must develop some initial concept of how the machine will operate.

Even though the virtual simulation of a mechanism has a firm place in engineering practice, it seldom conforms to real conditions, due to outside and inside influences, which can be difficult to predict and define. Therefore it is necessary to consider random influences and to multiply the results by surety factor.

Acknowledgement

Zahvala

This research was supported by the Ministry of Education of the Slovak republic, through grants VEGA num. 1/0885/10 and KEGA num. 270-014TUKE-4/2010 (RRC/03/2010), ASCR No. AV0Z30860518 and VEGA 1/0972/11.

4

References

Literatura

- [1] Bílek, O.; Lukovics, I. Finite Element Model of Dynamics within Highspeed Grinding Process. // *Academic Journal of Manufacturing Engineering*, (2009), 6-11. ISSN 1583-7904.
- [2] Ivandic, Z.; Ergic, T.; Kljajin, M. Welding robots kinematic structures evaluation of based on conceptual models using the potential method. // *Tehnicki Vjesnik-Technical Gazette*, 16, 4(2009), pp. 35-45.
- [3] Ergic, T.; Ivandic, Z. Ultra-light telescopic crane/platform mechanisms feature analysis. // *Tehnicki Vjesnik-Technical Gazette*, 16, 4(2009), pp. 87-91.
- [4] Rao, J. S.; Dukkupati, R. V. *Mechanism and Machine Theory*. // New Age International Ltd. Publisher, (1992), pp. 22-71. ISBN 81-224-0426-X
- [5] Trisovic, N.; Maneski, T.; Kozak, D. Developed procedure for dynamic reanalysis of structures. // *Strojarstvo*, 52, 2(2010), pp. 147-158.
- [6] Kušnerová M. et al. Derivation and Measurement of the Velocity Parameters of Hydrodynamics Oscillating System. // *Strojarstvo*, 50, 6(2008), pp. 375-379.
- [7] Ivandic, Z.; Ergic, T.; Kokanovic, M. Conceptual Model and Evaluation of Design Characteristics in Product Development. // *Strojarstvo*, 51, 4(2009), pp. 281-291.
- [8] Feneleon, M. A. A.; Furukawa, T. Design of an active flapping wing mechanism and a micro aerial vehicle using a rotary actuator. // *Mechanism and Machine Theory*, 45, 2(2010).
- [9] Eckhardt, Homer D. *Kinematic design of machines and Mechanisms*, McGraw-Hill Companies, (1998), pp.11-24, ISBN 0-07-018953-6

Authors' addresses

Adrese autora

Katarína Monková

Faculty of Manufacturing Technologies
of Technical University of Košice with seat in Prešov
Bayerova 1, 080 01 Prešov
Slovak Republic

Peter Monka

Faculty of Manufacturing Technologies
of Technical University of Košice with seat in Prešov
Bayerova 1, 080 01 Prešov
Slovak Republic

Sergej Hloch

Faculty of Manufacturing Technologies
of Technical University of Košice with seat in Prešov
Bayerova 1, 080 01 Prešov
Slovak Republic

Jan Valiček

Faculty of Mining and Geology
VŠB - Technical University of Ostrava
17 Listopadu, 708 33 Ostrava-Poruba
Czech Republic