

# Effect of Spring-Back and Spring-Forward in V-die Bending of St1403 Sheet Metal Plates

**Branko GRIZELJ<sup>1)</sup>,  
Josip CUMIN<sup>1)</sup> and Dejan GRIZELJ<sup>2)</sup>**

1) Strojarški fakultet u Slavonskom Brodu,  
Sveučilišta J. J. Strossmayera u Osijeku  
(Mechanical Engineering Faculty,  
J. J. Strossmayer University of Osijek),  
Trg Ivane Brlić-Mažuranić 2,  
HR-35000 Slavonski Brod,  
**Republic of Croatia**

2) Siemens Zagreb,  
Heinzelova, HR-10000 Zagreb,  
**Republic of Croatia**

[bgrizelj@sfsb.hr](mailto:bgrizelj@sfsb.hr)

## Keywords

*Bending  
Spring-back  
V-die*

## Ključne riječi

*Elastični povrat  
Savijanje  
V-alat*

**Received (primljeno):** 2009-09-01

**Accepted (prihvaćeno):** 2010-02-19

Preliminary note

Today there is widespread usage of high strength steels (HSS), and ultra high strength steels (UHSS) in the manufacturing industry. Especially in the automobile industry for the rigid and light weight chassis components made out of high strength steel. During sheet metal forming material undergoes plastic deformations and after the process of forming and taking out of the tool, formed sheet metal plate try to take previous position and elastically deforms. This deformation is called elastic spring-back. Special version of this elastically unloading is called spring-forward. It can be seen in V-die bending with small punch radius, and small punch angle which is shown in this paper.

## Pojava pozitivnog i negativnog elastičnog povrata pri savijanju lima od materijala St1403 u V-alatu

Prethodno priopćenje

Danas postoji široka upotreba visoko čvrstih i ultra visoko čvrstih čelika u industriji. Posebno u automobilske industriji za izradu krutih i laganih komponenti karoserija automobila izrađenih od visoko čvrstih čelika. Tijekom oblikovanja metalnog lima dolazi do plastičnih deformacija i nakon završenog procesa i vađenja izratka iz kalupa oblikovani lim pokušava zauzeti prethodni oblik pri čemu se elastično deformira. Ta deformacija se naziva elastičan povrat. Poseban oblik elastičnog povrata je negativni povrat. Ova pojava se može vidjeti kod savijanja u V-alatu uz mali radijus vrha alata i malen kut žiga, što je pokazano u ovom radu.

## 1. Introduction

Today there is widespread usage of high strength steels (HSS), and ultra high strength steels (UHSS) in the manufacturing industry. Especially in the automobile industry for the rigid and light weight chassis components made out of high strength steel. Light weight constructions of automobile chassis are energy efficient because of reduced fuel consumption, and today in the world's energy crisis it is important to reduce automobile fuel consumption. Also light weight constructions have other numerous advantages. During metal forming sheet metal plate undergoes plastic deformations which cause material strength hardening. With this strength hardening during sheet metal forming process, the product becomes

rigid. High strength steels can have stresses during forming more than 1000 MPa. Sometimes parts made by metal forming from high strength steel can be cut only with the use of laser or abrasive water jet.

V-die bending is process where sheet metal plate is bended with punch touching plate in the middle, and the ends of a plate lie on the die ends. Figure 1. shows V-die bending tool with punch having 90° angle and radius 4 mm, lower die of opened type and also 90° angle and placed sheet metal plate before process of bending.

In the past many researchers have studied V-die bending, and tried to make expressions for spring-back calculation. It was determined in all of these investigations that there are many parameters like material yielding stress, die arc, die clearance, plate thickness, punch tip

### Symbols/Oznake

$\alpha_2$	- bending angle after withdrawal of pressure, ° - kut savijanja nakon rasterećenja	$F$	- force, N - sila
$\alpha_{wz}$	- die angle, ° - kut alata	$\nu$	- Poisson's ratio - Poissonov omjer
$E$	- modul of elasticity, GPa - modul elastičnosti	$\varphi$	- true strain - stvarna deformacija
$\varepsilon_p$	- plastic portion of true strain - plastični udio stvarne deformacije	$R_{p02}$	- yield stress, MPa - naprezanje tečenja
$k_f$	- hardening stress, MPa - naprezanje očvršćavanja	$R_m$	- ultimate tensile strength, MPa - vlačna čvrstoća
$n$	- strain hardening exponent - eksponent krivulje očvršćenja	$t$	- time, s - vrijeme

radius, opened or closed type of die (Figure 2.), which influence on the amount of elastical spring-back.

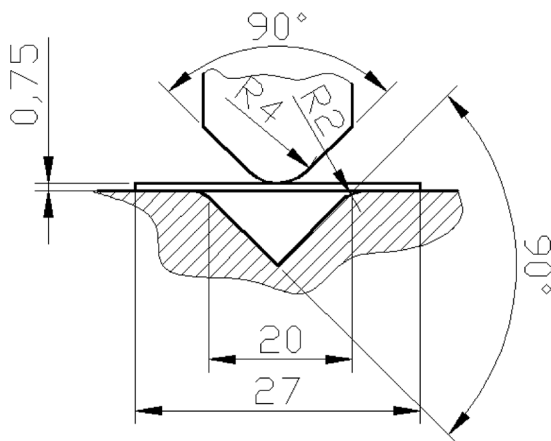

**Figure 1.** V-die tool for sheet metal bending  
**Slika 1.** V-alat za savijanje lima

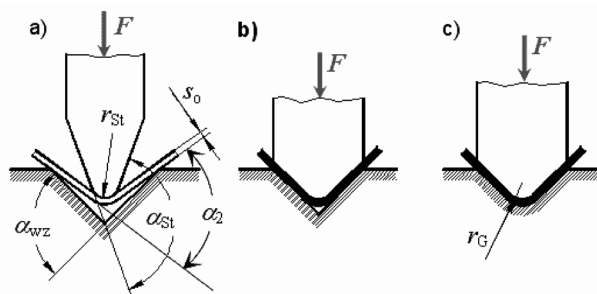

**Figure 2.** Types of V-dies: a) opened, b) half-opened, c) closed die. [1]

**Slika 2.** Tipovi V-alata: a) otvoreni, b) poluotvoreni, c) zatvoreni alat. [1]

Since in every V-bending process some amount of elastical spring-back appear, it is necessary to modify bending tools in order to obtain required bending angles and close tolerances. Modifying the tool is a trial and error process, and it is time expensive. Nowadays powerful Finite Element Methods are applied to simulate V-bending process, and to approximate the amount of spring-back. W. M. Chan et al. [2] investigated the effect of spring-back with FEM analysis and concluded that the spring-back reduces with increased punch angle and punch radius. They also determined that with larger deformation zone (especially in closed V-die shown in Figure 1.C) the effect of spring-back is also reduced [2]. Z.T. Zhang and S. J. Hu investigated stress and residual stress in plane strain bending, and concluded that the stress distribution of a part before unloading decides amount and direction of the elastical unloading [3]. W. L. Xu et al. investigated sensitive factors in FEM springback simulations [4]. They concluded that FEM analysis is very complicated because of various input parameters such as material constitutive law, strain hardening curve, FEM element type, contact model, friction law, material and geometrical nonlinearities [4]. They also proposed standard test for evaluating FEM results. This standard test was calculation of bending and springback with pure bending moment. During V-die bending, contact friction causes membrane stress in the bend area which is superimposed to pure bending stress [4]. This leads to errors between experiments, and FEM simulations [4].

W. Frącz and F. Stachowitz compared conventional pure bending theory with FEM simulations and experimental results and concluded that in the history most of the analytical approaches were based on the simple beam and plate bending theories [5]. They concluded that FEM method is proposed to simulate sheet

bending process because they make a good approximation of results and allow a significant reduction in costs because of less needed trials and tool corrections before production of parts [5]. S. Thipprakmas and S. Rojananan investigated spring-back and spring-forward effects with FEM method. They concluded that the phenomenon of spring-forward was rarely investigated, and that this phenomenon needs to be further theoretically researched [6]. When sheet metal plate is bended, outer „fibers” are under tension, and inner „fibers” are under compression. The neutral line divides tension and compression areas [6]. When sheet metal plate is released of loads – fibers under tension tries to contract, and fibers under compression tries to extend, thus sheet metal plate opens until remaining stresses are in equilibrium. This is the effect of spring-back. According to [6] the phenomenon of spring-forward yet needs to be investigated.

## 2. FEM simulation of V-bending of St1403 sheet metal plate

Two FEM simulations with different tool geometries were performed. The geometry with respective dimensions of the first tool is shown in Figure 1. Figure 3. shows geometry with respective dimension for second V-die bending tool. Punch has smaller angle (75°), and smaller tip radius as compared to first tool.

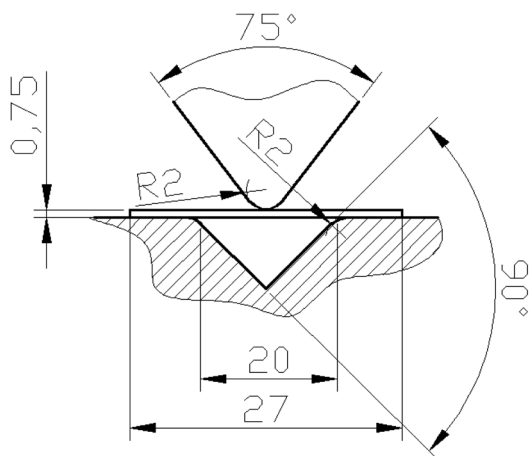

Figure 3. Second V-die bending tool geometry  
Slika 3. Geometrija drugog alata za savijanje

Punch and die was modeled as rigid bodies. Contact table determines contact and friction between rigid bodies and deformable body that is finite element mesh. Sheet metal plate was meshed by elements of size 0,15 x 0,15 so that the aspect ratio is one. Problem is modeled as plane strain with the option of assumed strain in MSC.MARC. Element type 11 was chosen, which is a four node isoparametric element written for plane strain

applications [7]. This element by default uses bilinear interpolation which results in poor presentation in bending simulations. This behavior is substantially improved with enabled option of alternative interpolation function which is done through assumed strain option in program [7]. Fine mesh is necessary to obtain good results with this element [7].

Figure 4. shows FEM model with defined contact bodies and boundary conditions of V-die with 90° punch angle (first tool), and Figure 5. shows 75° punch (second tool).

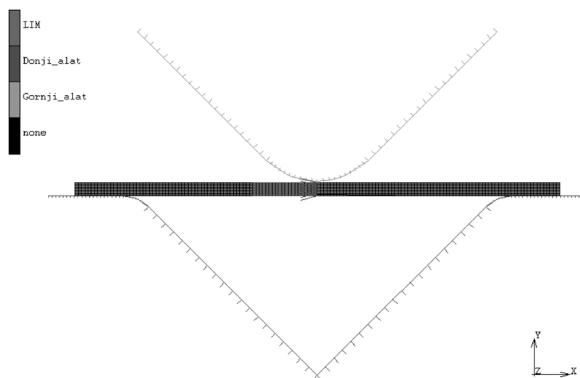

Figure 4. FEM model of 90° V-die bending tool from Figure 1  
Slika 4. MKE model alata za savijanje s kutom od 90° koji je prikazan na Slici 1

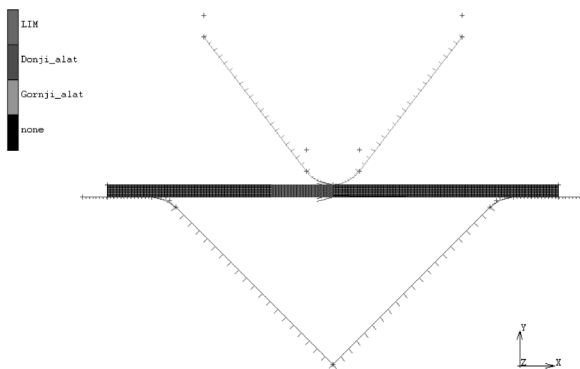

Figure 5. FEM model of 75° V-die bending tool from Figure 3  
Slika 5. MKE model alata za savijanje s kutom od 75° koji je prikazan na Slici 3

Steel St1403 is German DIN designation, European norm BS EN 10130:1999 is old designation for the same material. New EU norm is EN DC04 (1.0338) [8].

This material has the following mechanical properties [9]:

yield stress,  $R_{p02} = 157$  MPa

ultimate tensile stress,  $R_m = 309.2$  MPa

n value,  $n = 0.242$

Flow curve is approximated with expression:

$$K_f = 556 (0.0058 + \varphi)^{0.243}, \text{ MPa} \quad (1)$$

The strain hardening curve is supposed to be entered in the form of plastic portion of true strain/true stress. These calculations are done by expression:

$$\varphi_p = \varphi - \frac{k_f}{E},$$

where  $E$  represents Young's modulus of elasticity. For steel sheet metal plate St1403 Young's modulus of elasticity is  $E = 210$  GPa. Flow curve for St1403 material is shown in Figure 6.

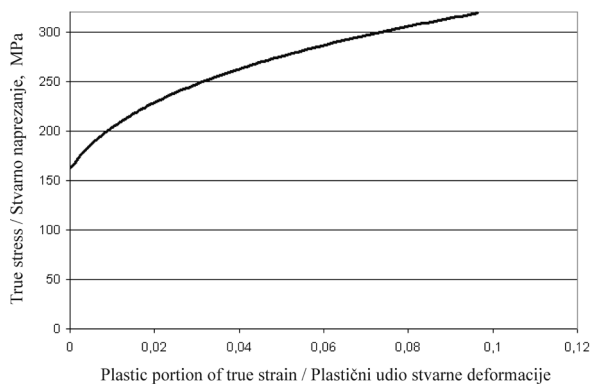

Figure 6. Flow curve for St1403

Slika 6. Krivulja tečenja za St1403 materijal

Poisson's ratio  $\nu = 0.3$  was used in simulation. Material was described numerically as isotropic elastic-plastic material with isotropic hardening rule and piece-wise linear strain rate method. Yield surface was calculated according to vonMises. Upper tool (punch) position was defined as a function of time. At the time  $t = 0$  s, punch position was set as 0 mm. At the time  $t = 5$  s, sheet metal plate was in contact with die and punch. All points between were extrapolated during simulation. At desired values of punch path, the upper tool (punch) was stopped, and reversed in other direction, so sheet plate could elastically return. Values of angle between sheet plate ends were measured in each time increment before, and after the unloading.

### 3. Results

Results were observed as relative bending angle which is calculated according to expression (2):

$$O_a = \frac{\alpha_2 - \alpha_{wz}}{\alpha_{wz}}, \quad (2)$$

where:

$\alpha_2$  - bending angle after withdrawal of pressure,

$\alpha_{wz}$  - die angle.

Figure 7. shows bending angles before and after withdrawal of punch.

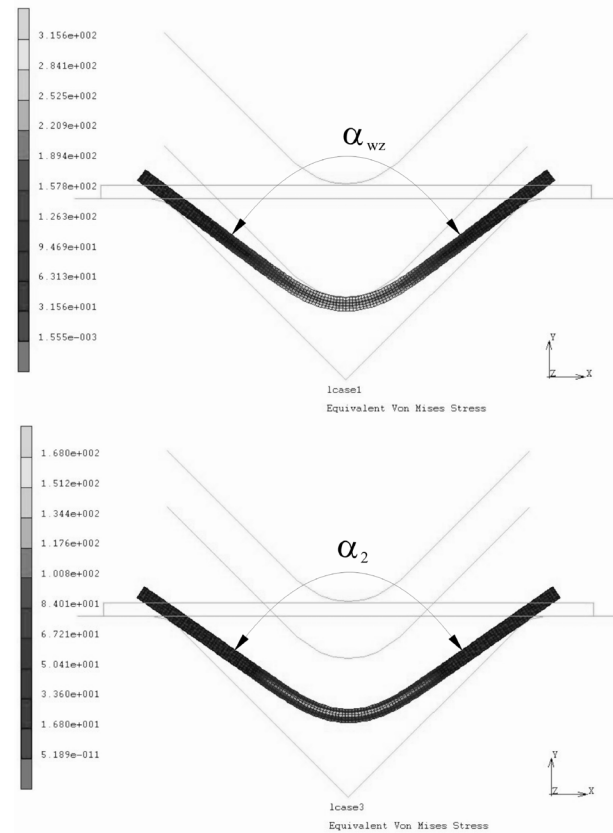

Figure7. Bending angles before and after unloading

Slika 7. Kutevi savijanja prije i poslije rasterećenja

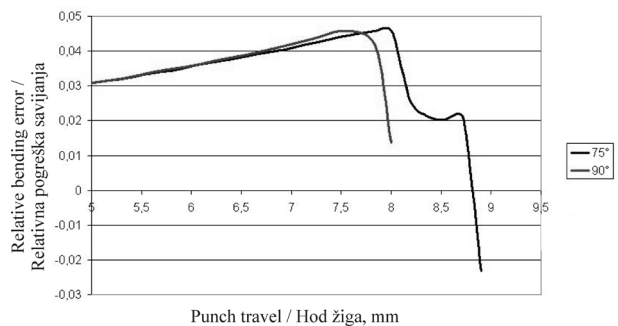

Figure 8. Relative bending error as a function of punch travel for both tool models

Slika 8. Relativna pogreška savijanja kao funkcija hoda žiga za oba modela alata

Figure 8. shows results of FEM simulations in the form of relative bending error as a function of punch travel. One can see that in case of V-die bending tool with

75° angle of punch, at the end of a punch travel sheet metal plate has negative bending error, which is the effect known as spring-forward.

move toward the punch. This phenomenon occurs at the near end of a punch stroke, and from Figure 8. one can see that at the end of a punch stroke negative relative bending error occurs.

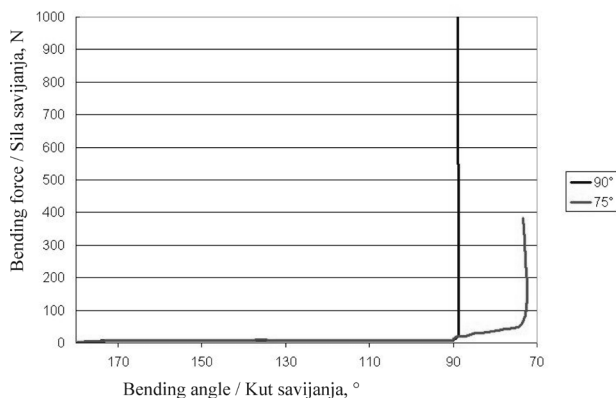

**Figure 9.** Bending force as a function of bending angle  
**Slika 9.** Sila savijanja kao funkcija kuta savijanja

Figure 9. shows calculated bending force on the punch for both V-die tool models. One can see that bending force of both tools is similar up to angles of 90°. After this angle, bending force for 90° tool rises abruptly to 3170 N (not shown in diagram) because of the effect of coining, also known as calibration of sheet metal plate. During calibration sheet metal plate is in contact with both punch and die, and force causes plastic large plastic deformation. It is commonly known that with large plastic deformation in the bended area – the amount of springback is reduced. Also 75° V-die tool shows the effect of spring-forward which means that after unloading sheet metal plate took even lower angle than before unloading. Also one can see that the bending force is lower in the case of 75° V-die tool because in this case there is coining (calibration).

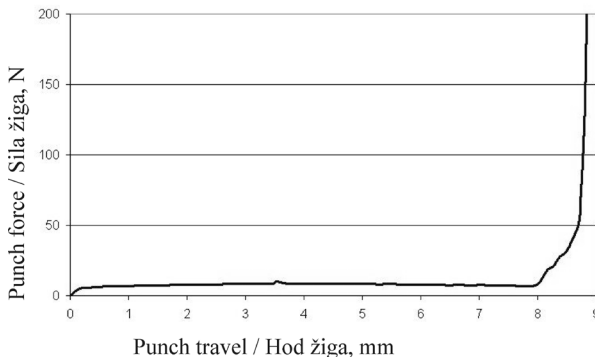

**Figure 11.** Punch force as a function of punch travel for 75° tool

**Slika 11.** Sila na žig kao funkcija hoda žiga za alat od 75°

#### 4. Conclusions

Today with application of modern materials the designer’s objective is to make light weight constructions, and to keep structural rigidity, dimensional accuracy and strength of the parts. Usually those products are various high-tech gear, and most widely spread application is the sheet metal forming of automobile structural parts from high strength steel. The problem with high strength steel plates is their poor dimensional accuracy because of large springback effect. Usually theoretical approach for analytical description of V-die bending is the loading with pure moment, which was investigated by many scientists in the past. Today powerful numerical FEM methods are used to predict the amount of springback (or spring-forward) on simple parts, as well as on complicated parts. Accuracy of results of FEM analysis depends on many factors like material constitutive law, strain hardening, hardening law, element type, contact model, friction law description, mesh density, element aspect ratio, number of integration points in elements etc. Two different tool geometries for V-die bending were simulated. Results show that in 90° tool calibration force is significantly larger than in 75° tool. Also the amount of relative bending error is similar up to punch travel of 7,5 mm. This is due to effect of free plate bending, after which strain hardening due to material deformation changes.

It can be seen form Figure 8. that in the case of 75° V-die bending tool it is possible to obtain negative relative bending error. Also form Figure 9. it can be seen that the bending angle after unloading drops, that is angle after unloading is smaller than the angle before unloading.

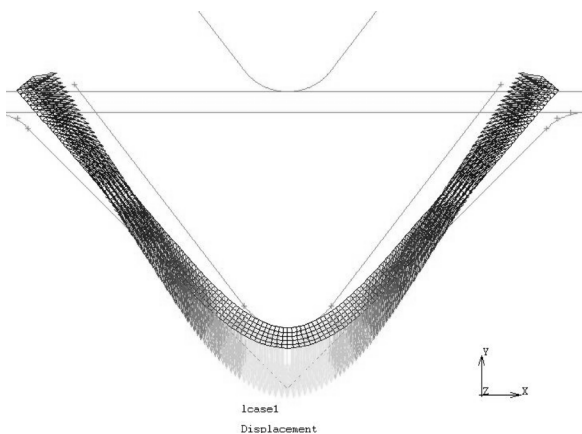

**Figure 10.** Displacement vector plot

**Slika 10.** Prikaz vektora pomaka

Figure 10. shows displacement vector plot, and one can see that ends of a sheet metal plate during bending



**REFERENCES**

- [1] GRIZELJ, B.: *Oblikovanje metala deformiranjem*, Strojarški fakultet, Slavonski Brod, 2002, pp 282.
- [2] CHAN, W. M.; CHEW, H. I.; LEE, H. P.; CHEOK, B. T.: *Finite element analysis of spring-back of V bending sheet metal forming process*, Journal of materials processing technology 48 (2004), pp 15-24.
- [3] ZHANG, Z. T.; HU, S. J.: *Stress and residual stress distributions in plane strain bending*, Int. J. Mech. Sci, Vol 40 (1998), No.6, pp533-543.
- [4] XU, W. L.; MA, C. H.; LI, C. H.; FENG, W. J.: *Sensitive factors in springback simulation for sheet metal forming*, Journal of Materials Processing technology 151 (2004), pp 217-222.
- [5] FRACZ, W.; STACHOWITZ, F.: *Springback phenomenon in sheet metal V-die air bending – experimental and numerical study*, Manufacturing engineering (Výrobné inžinierstvo), Year 2008, Issue 2, pp 34-37.
- [6] THIPPRAKSMAS, S.; Rojananan, S.: *Investigation of spring-go phenomenon using finite element method*, Materials and design 29 (2008), pp 1526-1532.
- [7] MSC.MARC manual, *Volume B: Element library*, MSC. Software Corporation, pp 152-155.
- [8] ROYMECH: *Strength of steels*, URL: [http://www.roymech.co.uk/Useful\\_Tables/Matter/Steel\\_Europe.html](http://www.roymech.co.uk/Useful_Tables/Matter/Steel_Europe.html) (25.11.2009.)
- [9] RAGAB, M. S. and ORBAN, H. Z.: *Effect of ironing on the residual stresses in deep drawn cups*, Journal of Materials Processing Technology, vol. 99, issues 1-3, March 2000, pp 54-61. (doi: 10.1016/S0924-0136(99)00360-X).