

Teresa Orlowska-Kowalska, Mateusz Dybkowski, Czeslav T. Kowalski

Rotor Fault Analysis in the Sensorless Field Oriented Controlled Induction Motor Drive

UDK 621.313.33.073
IFAC 5.5.4; 3.2.1

Original scientific paper

In the paper an analysis of the Direct Field Control of induction motor drive with broken rotor bars is presented. A drive system with and without a mechanical speed sensor is analyzed. In the sensorless induction motor (IM) drive the rotor flux and speed is reconstructed with the use of a MRAS^{CC} estimator, where the induction motor is used as a reference model. The stator current estimator and current model of the rotor flux are used as adapted models. Most of the speed estimators used in sensorless drives are sensitive to motor parameter changes, especially to the rotor resistance changes. The proposed MRAS^{CC} estimator is very robust to all motor parameter changes, hence it should work properly in a faulty rotor. In the paper simulation and experimental results of the sensorless IM drive with broken rotor bars are presented. Characteristic frequency harmonics of the IM state variables connected with the broken rotor bars are introduced. The low speed region and the dynamic properties of the IM drive with rotor faults are tested. The range of stable work of the control system is shown.

Key words: Induction motor, Vector control, Sensorless control, Speed estimator, Rotor flux estimator, Rotor fault, Diagnostics

Analiza kvarnih stanja rotora vektorski upravljano asinkronog stroja bez mehaničkog senzora brzine vrtnje. U radu je prikazano izravno upravljanje poljem asinkronog motora s prekinutim rotorskim štapovima. Analiziran je elektromotorni pogon s mehaničkim senzorom brzine i bez njega. Pri upravljanju bez mehaničkog senzora brzine rotorski tok i brzina rekonstruirani su korištenjem MRAS^{CC} estimatora, pri čemu je asinkroni stroj korišten kao referentni model. Estimator statorske struje i strujni model rotorskog toka korišteni su za adaptaciju modela. Većina estimatora brzine vrtnje koji se koriste u pogonu bez mehaničkog senzora brzine osjetljivi su na promjenu parametara stroja, posebno na promjenu rotorskog otpora. Predloženi je MRAS^{CC} estimator robustan na promjene parametara motora pa je moguć rad i u kvarnom stanju rotora. U radu su prikazani simulacijski i eksperimentalni rezultati pogona bez mehaničkog senzora brzine pri prekinutim rotorskim štapovima. Uvedene su frekvencije karakterističnih harmonika varijabli stanja asinkronog motora povezane s prekinutim rotorskim štapovima. Analizirano je područje malih brzina vrtnje te dinamičke značajke pogona s asinkronim motorom s rotorom u kvarnom stanju. Prikazano je područje stabilnog rada sustava upravljanja.

Ključne riječi: asinkroni motor, vektorsko upravljanje, estimator brzine vrtnje, estimator rotorskog toka, kvarno stanje rotora, dijagnostika

1 INTRODUCTION

Induction motor drives are the most popular in industry nowadays. Due to their low cost, reliability, and control abilities induction motors (IM) are widely used in different drive applications. On the other hand, the advanced control structures require state variable estimation [1, 2] what is more, a modern drive system should be equipped with diagnostic features to prevent damages and sudden switch-offs of complex industrial installations. Thus the incipient fault detection is recently one of the basic requirements for modern induction motor drive systems [3]. Moreover, in sensorless drives, the used state variable estimators should

be robust to motor parameter uncertainties, as the stator or rotor winding faults cause changes in parameters of the motor equivalent circuit.

In the direct rotor field-oriented vector-controlled induction motor drives (DRFOC) the fault symptoms can be observed as characteristic frequencies of stator current components, rotor flux magnitude, control voltages and decoupling signals. So the monitoring of these signals can be useful from the diagnostic point of view.

In this paper an analysis of a DRFOC induction motor drive with a faulty rotor is presented with respect to direct rotor speed measurement as well as a speed sensorless operation. The rotor flux and speed are reconstructed by a

MRAS^{CC} estimator [4] (based on Model Reference Adaptive System concept). Both simulation and experimental results of an IM drive with broken rotor bars are presented in the paper. The characteristic frequency harmonics of the IM state variables connected with broken bars are introduced and fault symptoms are shown. The range of the stable operation of the control system with broken rotor bars of the induction motor is presented.

2 SHORT DESCRIPTION OF THE CONTROL STRUCTURE

The rotor flux-oriented vector control structure (DRFOC) of the induction motor drive with a direct speed measurement or speed reconstructed using MRAS^{CC} rotor speed estimator, presented in Fig. 1, is analyzed under faulty conditions.

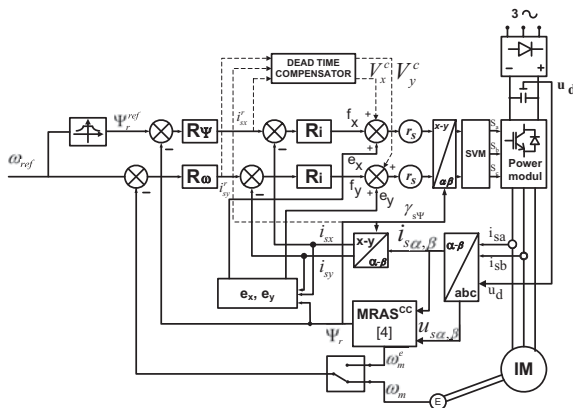

Fig. 1. Schematic diagram of the sensorless DRFOC drive with MRAS^{CC} estimator

First the drive control structure was tested under faulty rotor conditions with a direct speed measurement. Next the influence of the broken rotor bars on the performances of the sensorless control structure was investigated.

It is well known that a signature of broken rotor bars is connected with the stator current harmonics of frequency $(1 \pm 2s)f_s$, for net supply of an induction motor. In the closed-loop control structure (DRFOC, etc.), the stator currents are determined by a control action, hence these signatures can not be directly applied. Specific signature should be found in signals available in the control structure.

The main goal of this research was an analysis of the rotor fault influence on the control signals of the Direct Rotor Flux Oriented Control structure (DRFOC) and determination of the fault signature visible in the chosen control signals. The study will enable the automatic detection of the rotor fault in the future, using e.g. neural detectors based on multilayer networks.

The other goal of the study was the application of such speed estimator that enables the stable operation of the drive even for relatively big number of broken bars. For this reason the rotor speed and flux estimator MRAS^{CC} was used, as it is very robust to motor parameter changes, which was proved in [4,5]. A detailed mathematical model and stability analysis of this MRAS^{CC} estimator is shown in [6,7]. This estimator consists of two independent models of rotor flux and stator current, which provide inputs to the speed adaptation mechanism (as shown in Fig. 2). The estimated speed value returns the current flux model and stator current estimator. The induction motor is used as a reference in this MRAS and the measured stator current is compared with the estimated current obtained from the stator current model.

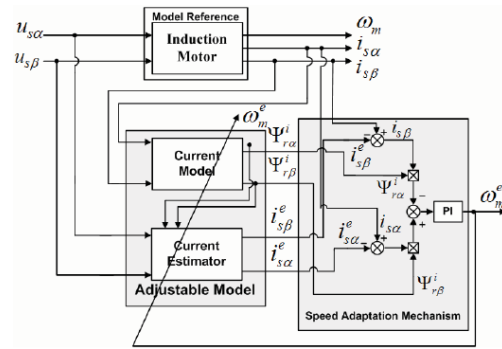

Fig. 2. Rotor speed reconstruction using MRAS^{CC} system

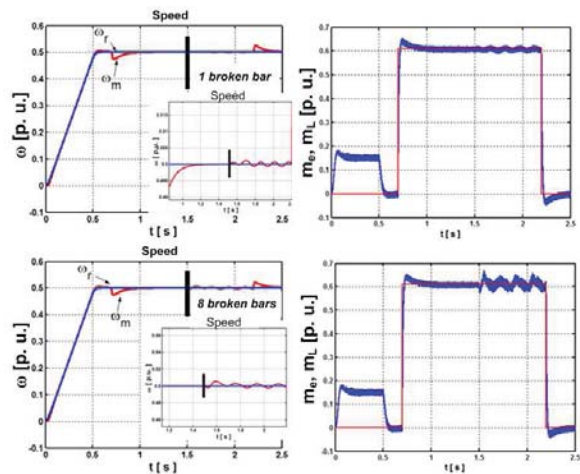

Fig. 3. Transients of the angular speed and the electromagnetic torque in the DRFOC structure under start-up and load torque ($m_L = m_N$) change, with 1 (first row) and 8 (second row) broken rotor bars at $t=1.5s$

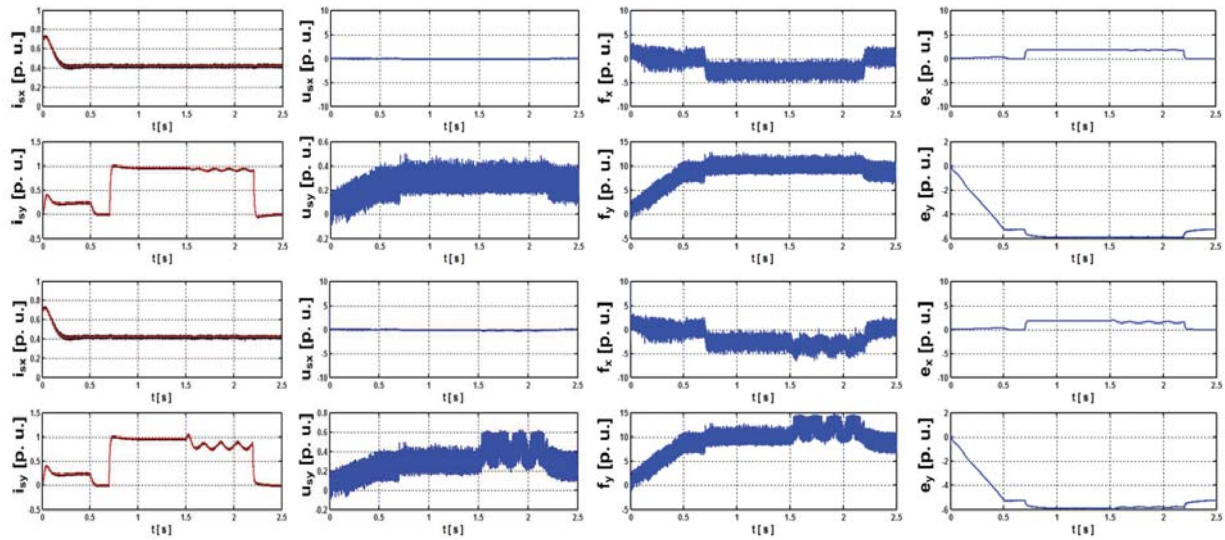

Fig. 4. Transients of the internal signals of DRFOC structure in the vector-controlled induction motor under start-up and load torque ($m_L = m_N$) change, with 1 (first row) and 8 (second row) broken rotor bars at $t = 1.5$ s

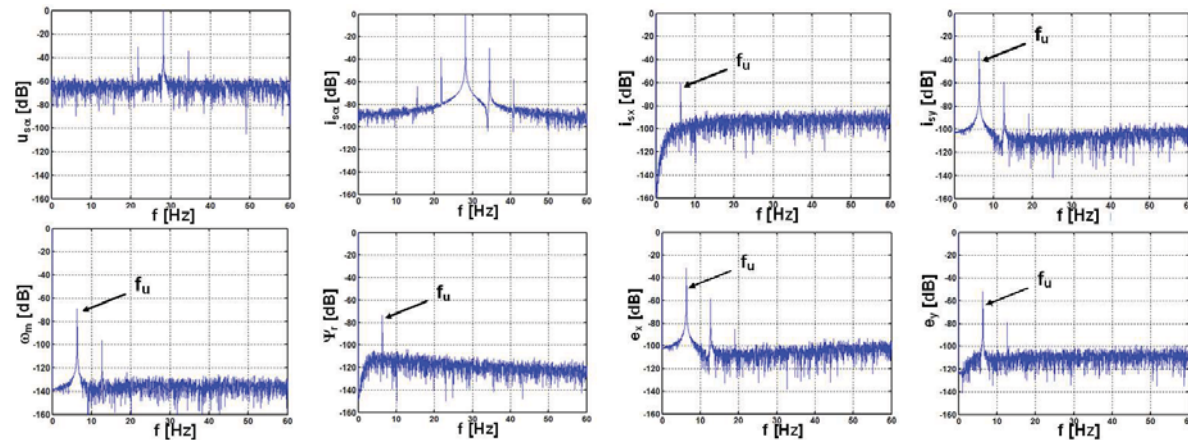

Fig. 5. FFT spectrum of chosen signals in the DRFOC structure with 2 broken rotor bars; $m_L = m_N$; from the left: first row - stator voltage and current components in a -axis, stator current components in field-oriented coordinates, second row - rotor speed, rotor flux magnitude, decoupling voltages in field-oriented coordinates

3 THE INFLUENCE OF THE ROTOR FAULT ON THE SPEED ESTIMATION QUALITY – A SIMULATION STUDY

3.1 Drive system operation with the speed measurement

In the simulation tests a simplified mathematical model of the induction motor with broken rotor bars was used [8]. The each rotor fault was modeled as a full broken rotor bar. All simulation tests were performed in per unit values [4]. The squirrel-cage rotor of the tested IM consists of 22 bars.

The maximum number of broken bars was 8 in simulations and the neighboring rotor bars were considered under fault.

In Fig. 3 transients of the rotor speed ω_m , electromagnetic m_e and load m_L torques under start-up and load changes of the drive system, in the case of sudden rotor fault (at $t = 1.5$ s) are shown. Simulation tests of DRFOC structure with different levels of faulted motor have enabled the observation of the internal signals of a control system, what is shown in Fig. 4.

An analysis of these internal signals of the closed-loop control structure makes possible a choice of the most suit-

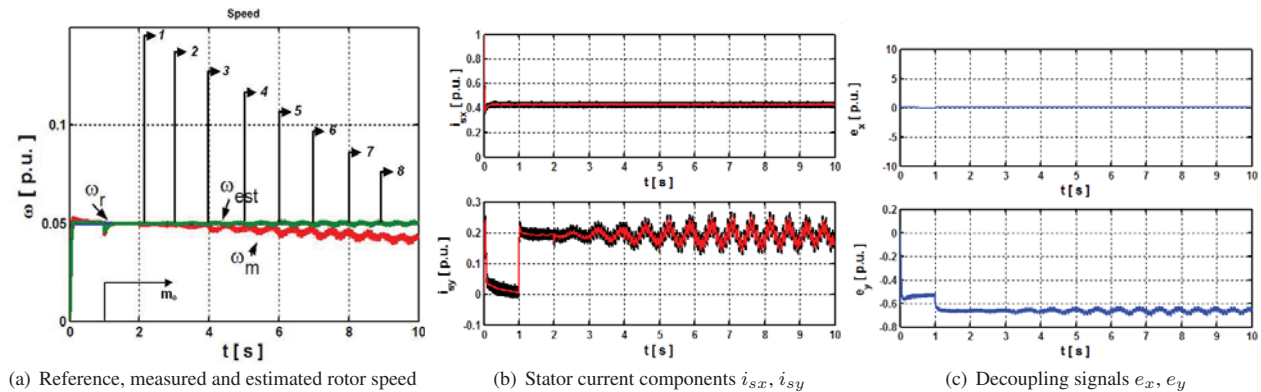

Fig. 7. Transients for $\omega_m = 0.05\omega_{mN}$, $m_L = 0.2m_N$

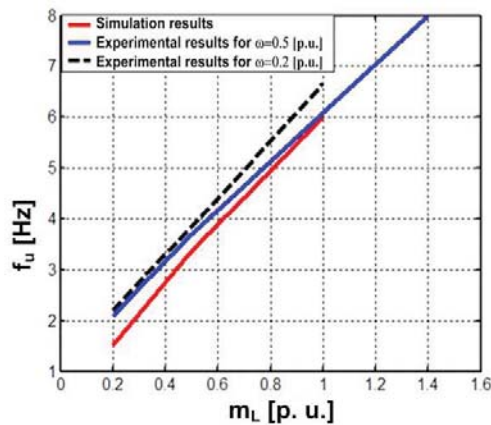

Fig. 6. The relationship between the frequency of characteristic rotor fault harmonic component and the load torque value for 4 broken rotor bars

able ones for fault signature detection, It was concluded that the most informative signals are: torque component of the stator current i_{sy} , decoupling signals e_x , e_y , magnitude of the rotor flux vector and the estimated rotor speed, as it is shown in Fig. 3 and Fig. 4.

In Fig. 5 the FFT spectrum of chosen signals in the DRFOC structure of induction motor drive with 2 broken rotor bars is shown for the nominal load torque of the motor. It was found that characteristic frequencies occurring in these signals do not depend on the actual rotor speed value, but are closely related to the actual load torque value and fault level.

The dependence of the frequency of the characteristic rotor fault harmonic component $f_u = 2sf_s$ (where f_s – frequency of supplying voltage of the motor) on the load torque value in the case of 4 broken rotor bars is illustrated

in Fig. 6. Tests were performed for two reference speeds of the motor. When the actual value of the load torque of the drive system is known, this information can be used for diagnostic purposes of the drive system. This relationship was also confirmed in the sensorless drive system operation.

3.2 Sensorless drive system operation

Next the drive system was tested in the sensorless version with the MRAS^{CC} speed estimator. Transients of the drive system state variables under faulty conditions are demonstrated in Fig. 7 and Fig. 8. In Fig. 7 the start-up of the sensorless drive with the relatively low reference speed $\omega_m = 0.05\omega_{mN}$ is demonstrated. In $t = 1$ s the load torque ($0.2m_N$) is applied. Then the following rotor faults are simulated, starting from 1 broken bar in $t = 2$ s, till 8 broken bars in $t = 9$ s. Similar test results, obtained under the full nominal load torque are presented in Fig. 8.

In the presented signals of the drive structure, the increase of the rotor damage level is clearly visible and characteristic frequency connected with rotor fault is observed. The value of fault frequency grows, according to the increasing fault level. For the same fault level it also grows with the load torque value (see Fig. 7 and Fig. 8), in line with correlation presented in Fig. 6.

Also the error between measured and estimated rotor speed raises significantly, which results from the sensitivity of the control structure and speed estimator to change of motor parameters due to the rotor fault. It should be mentioned, however, that the DRFOC structure with the proposed MRAS^{CC} speed and flux estimator works in a stable way in the whole speed range, as shown in Fig. 9. Despite the steady-state error increasing with the rotor fault level, the drive system does not lose stability and the speed estimator works properly, as it is less sensitive to motor parameter changes than other known speed estimators [5, 9].

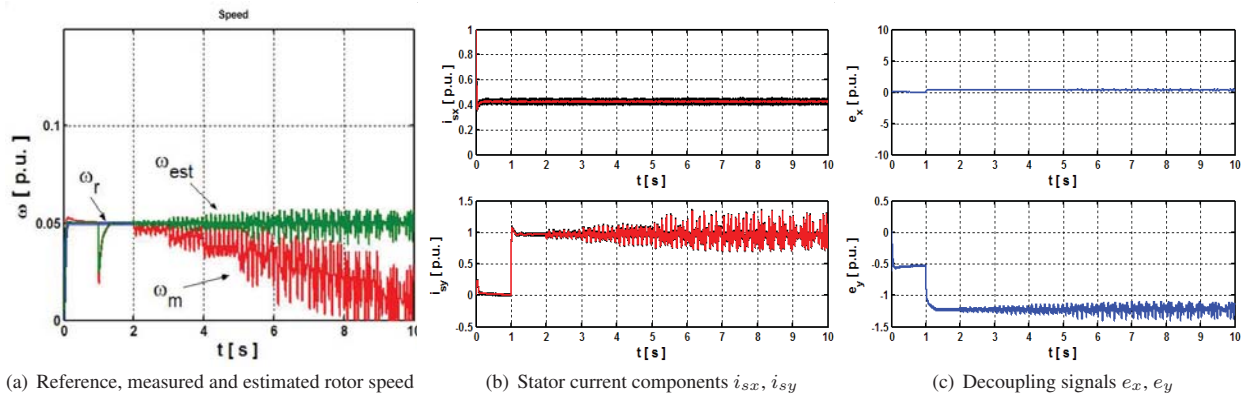

Fig. 8. Transients for $\omega_m = 0.05\omega_{mN}, m_L = m_N$

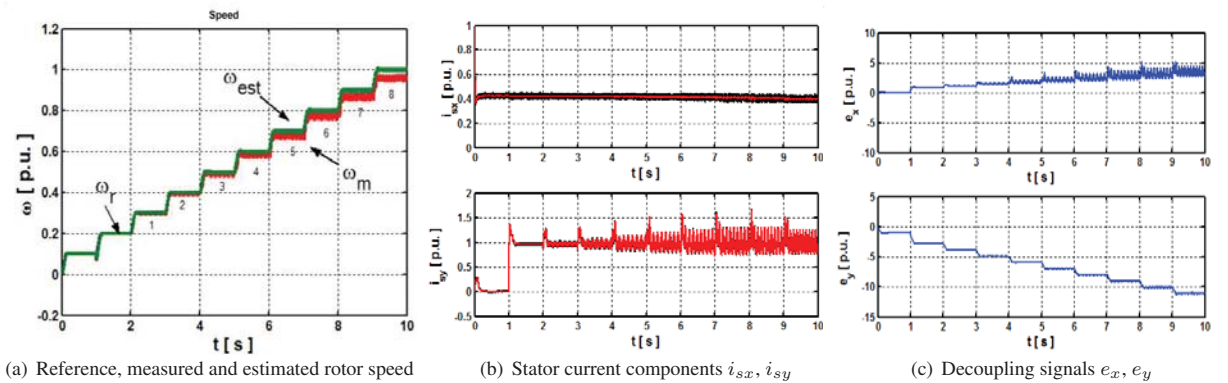

Fig. 9. Transients for $\omega_m = 0 \rightarrow \omega_{mN}, m_L = m_N$

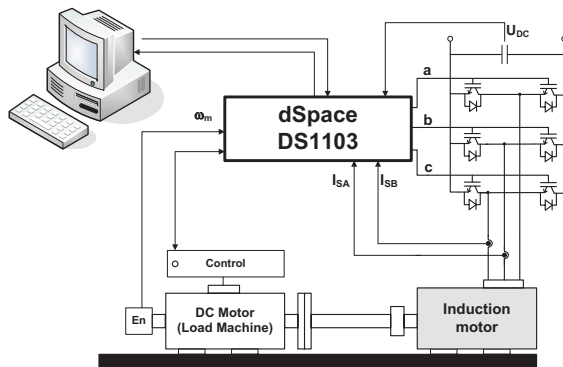

Fig. 10. Schematic diagram of the laboratory set-up

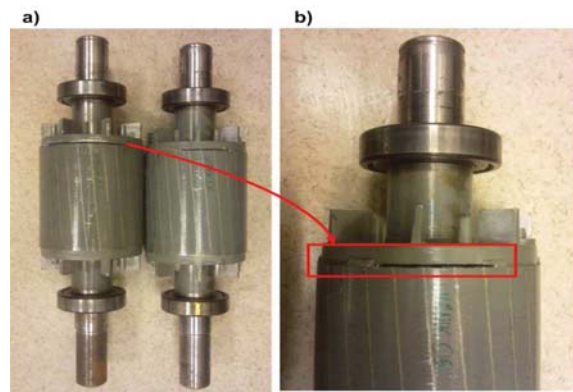

Fig. 11. Broken rotor bars (a) and zoom of the 8 broken rotor bars (b) using spark erosion machine

Still, for the drive system operation in a very low speed region (below $0.05\omega_{mN}$) and under full load torque, the damage of a few rotor bars can result in lack of the system response to the control signals, as seen in Fig. 8.

The sensorless drive works properly in the whole speed

range under the nominal load torque for insignificant rotor damage – in the tested case for maximum 3 broken bars.

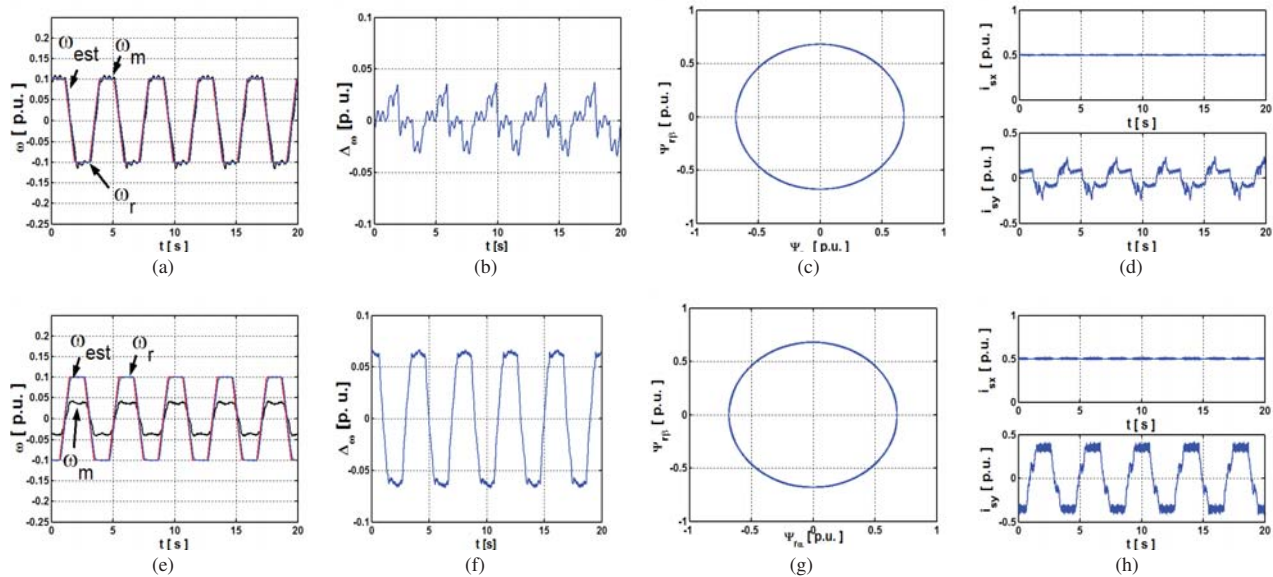

Fig. 12. Experimental transients of the sensorless drive with 2 broken rotor bars under reverse operation: (a,e) reference, measured and estimated rotor speed, (b,f) speed estimation error, (c) hodograph of the rotor flux vector, (d) stator current components i_{sx} , i_{sy} ; $m_L = 0.1m_N$ (a-d), $m_L = 0.5m_N$ (e-h); $\omega_m = 0.1\omega_{mN}$

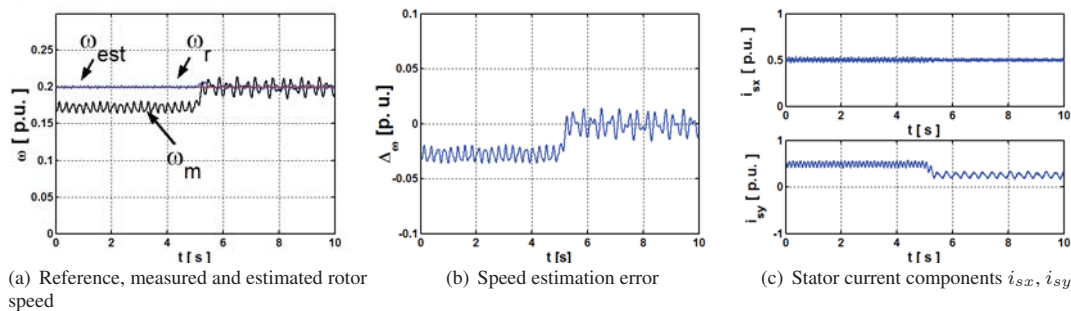

Fig. 13. Experimental transients of the sensorless drive with 2 broken rotor bars under load torque change from $m_L = 0.5m_N$ to $m_L = 0.2m_N$; $\omega_m = 0.2\omega_{mN}$

If the number of broken rotor bars grows, some problems occur under motor start-up as well as under its operation in a very low speed region (Fig. 8).

4 EXPERIMENTAL RESULTS

Experimental test of the DRFOC drive system with healthy and faulty motor were performed in the laboratory set-up equipped with a PC computer and DS1103 card, using the dSPACE software. The schematic diagram of the experimental test bench is displayed in Fig. 10.

The experimental set-up is composed of an IM motor (with changeable rotors) fed by an SVM-voltage inverter. The motor is coupled to a load machine. The driven motor

has the nominal power of 1.5 kW. The speed of the drive is measured by an incremental encoder (36000 imp./rev), only for the comparison with the estimated speed in the sensorless drive system. The stator current is measured with LEM LA25 transducers. The control and estimation algorithms are implemented in the DS1103 card.

In Fig. 11 the illustrations of the squirrel cage rotor with damaged rotor bars of are shown. These rotor bars were cut with the use of the spark erosion machine.

In the next figures experimental transients of the drive system with faulty motor (with 2 broken rotor bars) are presented for low reference speed values.

It should be noticed, that even such incipient fault level,

as seen in the submitted figures, enables the proper conclusion on the drive system condition. The significant speed estimation error is visible after load torque change and the characteristic frequency harmonic component caused by the rotor fault can be detected in the rotor speed and torque component of the stator current. The influence of the load torque change on the operation quality of the sensorless drive with a faulty induction motor is demonstrated in Fig. 12. The estimation error between the measured and estimated rotor speed grows significantly, according to the increase of the load torque value (Fig. 12 e-h). On the other hand, the decrease of the load torque causes the expected change in the fault frequency as well as a lower speed estimation error (as in Fig.13).

Experimental results obtained for the sensorless drive with a MRAS^{CC} estimator and faulty induction motor confirm simulation results. The steady-state speed estimation error can cause some problems in the drive start-up, especially for the low speed region. But due to fault signature, which can be observed in some internal signals of the control structure, even incipient rotor fault (1 or 2 broken rotor bars) can be detected by a suitable diagnostic procedure.

5 CONCLUSION

The presented simulation and experimental results show the possibility of stable operation of the sensorless DRFOC drive system with faulted rotor only, when the suitable speed estimator is used. The application of MRAS^{CC} rotor speed and flux estimator [8, 9] enables such operation of the control structure.

Selected internal signals of such a control structure can be used as fault signatures for diagnostic purposes. If the fault frequency f_u harmonics are detected in these signals, the fault severity is possible even for one broken rotor bar.

Even more important, for higher rotor speed references the drive system with MRAS^{CC} estimator can work in a stable way for much bigger rotor faults (three or more broken rotor bars), which is a significant advantage of the used solution in drives which are subject to frequent damage due to hard industrial conditions.

ACKNOWLEDGMENT

This research work was partially supported by the Ministry of Science and Higher Education of Poland under Grant R0101403 (2007-2010).

REFERENCES

- [1] M. P. Kazmierkowski, F. Blaabjerg, and R. Krishnan, *Control in Power Electronics – Selected Problems*. San Diego: Academic Press, 2002.
- [2] P. Vas, *Sensorless vector and direct torque control*. New York: Oxford University Press, 1998.
- [3] S. Nandi and H. Toliyat, "Condition monitoring and fault diagnosis of electrical machines – a review," in *Conference Record of the 1999 IEEE-IAS Annual Meeting*, (Phoenix, Arizona, USA), pp. 197–204, 1999.
- [4] T. Orłowska-Kowalska and M. Dybkowski, "Dynamical properties of induction motor drive with novel MRAS estimator," *Electrical Review (Przegląd Elektrotechniczny)*, vol. 82, no. 11, pp. 35–38, 2006.
- [5] K. Ohyama, G. M. Asher, and M. Sumner, "Comparative analysis of experimental performance and stability of sensorless induction motor drives," *IEEE Transactions on Industrial Electronics*, vol. 53, no. 1, pp. 178–186, 2006.
- [6] M. Dybkowski and T. Orłowska-Kowalska, "Application of the stator current-based MRAS speed estimator in the sensorless induction motor drive," in *Proceedings of the 13th EPE-PEMC 2008*, (Poznan, Poland), 2008.
- [7] M. Dybkowski and T. Orłowska-Kowalska, "Stator current-based MRAS estimator for a wide range speed-sensorless induction motor drive," *IEEE Transactions on Industrial Electronics*, vol. 57, no. 4, pp. 1296–1308, 2010.
- [8] M. Pawlak and T. Orłowska-Kowalska, "Application of the simplified two axial model for rotor faults modeling of the induction motor," *Electrical Review (Przegląd Elektrotechniczny)*, vol. 82, no. 10, pp. 48–53, 2006.
- [9] T. Orłowska-Kowalska and M. Dybkowski, "Improved MRAS-type speed estimator for the sensorless induction motor drive," in *Proceedings of the XIX Symposium on Electromagnetic Phenomena in Nonlinear Circuits*, (Maribor, Slovenia), pp. 105–106, 2006.



Teresa Orłowska-Kowalska received the Ph.D. and D.Sc. degrees from Wrocław University of Technology, Wrocław, Poland, in 1976 and 1990, respectively. Since 1993, she has been a Professor of electrical engineering and the Chair of the Electrical Drives Control, Institute of Electrical Machines, Drives, and Measurements, Wrocław University of Technology. She is an author and co-author of more than 300 journal papers and conference proceedings, two textbooks, and fourteen chapters in monographs. Her research inter-

ests include the mathematical modeling and microprocessor control of electrical drives and power electronic systems, the application of modern control methods to electrical drives, the state estimation of induction motors using state observers, Kalman filters, and neural networks, and, in the last few years, neural networks and fuzzy-logic techniques applied to electrical drives control. Prof. Orłowska-Kowalska is a member of the Electrical Engineering Committee of the Polish Academy of Science, the European Power Electronics Association, the International Council on Large Electric Systems (CIGRE), and international steering committees of a few well-known European conferences. Since 1997, she has been a Reviewer of the IEEE Trans. on Industrial Electronics and the IEEE Trans. on Industry Applications. Since 2004, she has been an Associate Editor for the IEEE Trans. on Industrial Electronics.



Mateusz Dybkowski Mateusz Dybkowski received the M.Sc. and Ph.D. degrees from the Electrical Engineering Faculty, Wrocław University of Technology, Wrocław, Poland, in 2004 and 2008, respectively. Since 2008, he has been a member of the academic staff with the Electrical Drives Control, Institute of Electrical Machines, Drives and Measurements, Wrocław University of Technology. He is an author and co-author of close to 50 scientific papers. His main field of interest is the induction motor drive control and state variable estimation, control theory applications in electrical drives, digital signal processors, and field-programmable gate array applications.



Czesław T. Kowalski received the Ph.D. and D.Sc. degrees in 1983, 2006 respectively, from the Electrical Engineering Faculty of Wrocław University of Technology. Since 1983 he has the associated professor's position and next - since 2009 - the professor's position at this faculty and is a staff member of Electrical Drives Control Division in the Institute of Electrical Machines, Drives and Measurements. He is an author and co-author of close to 200 scientific papers. His field of interest is the mathematical modeling and microprocessor control of electrical drives, diagnostic methods of induction motor drives, with special emphasis on artificial intelligence applications.

AUTHORS' ADDRESSES

Prof. Teresa Orłowska-Kowalska, Ph.D., D.Sc.

Mateusz Dybkowski, Ph.D.

Czesław T. Kowalski, Ph.D., D.Sc.

Institute of Electrical Machines, Drives and Measurements,

Wrocław University of Technology

50-372, Wrocław, Poland

emails: teresa.orlowska-kowalska@pwr.wroc.pl,

mateusz.dybkowski@pwr.wroc.pl,

czeslaw.t.kowalski@pwr.wroc.pl

Received: 2010-03-13

Accepted: 2010-05-05