

IDEAL ELECTRICAL TRANSFORMER MODEL IN THE SYSTEM OF IMPEDANCE MATCHING OF PIEZOELECTRIC HYDROACOUSTIC TRANSDUCER

Model idealnog električnog transformatora u sustavu prilagođenja impedancije piezoelektričnih hidroakustičkih pretvarača

Zvonimir Milošić, Ph D

Institute for Research and Defense Systems, Ilica 256 b, 10000 Zagreb, Croatia
Ministry of Defense, Republic of Croatia, Trg kralja Petra Krešimira IV. 1, Zagreb, Croatia
E-mail: zvonimir.milosic@morh.hr

UDK 621.31

Summary

The subject of this paper is matching electrical hydroacoustic piezoelectric transducers, by means of an electrical transformer and a LC transformer, to the wave resistance of an antenna electric cable, which is connected to transceiver sonar. By using the ideal transformer model and LC transformer, special formulas were gained, which enables the correct computing of elements necessary for performance and complete matching of electrical impedance and the phase angle.

Key words: electrical impedance matching, ideal electrical transformer model, LC transformer, wave resistance of electric cable, piezoelectric hydroacoustic transducer, antenna, sonar.

Sažetak

U radu se obrađuje prilagođenje električne impedancije hidroakustičkoga piezoelektričnog pretvarača pomoću električnog transformatora i LC transformatora na valni otpor električnog kabela antene spojenog na elektronički sustav primo/predaje sonara. Koristeći model idealnog električnog transformatora i električnog LC transformatora, dobivene su posebne formule koje omogućavaju točan izračun potrebnih elemenata za izvedbu i potpuno prilagođenje modula električne impedancije i faznog kuta.

Ključne riječi: prilagođenje električne impedancije, model idealnog električnog transformatora, LC transformator, valni otpor električnog kabela, piezoelektrični hidroakustički pretvarač, hidroakustička antena, sonar.

INTRODUCTION / Uvod

Matching electrical impedance of the hydroacoustic transducer within this framework represents an important factor for a proper sonar or hydroacoustic underwater monitoring system function. This activity ensues from the necessity that electrical signals have cophasal relationships both at the input and output of the electronic system. Disturbances are caused

by piezoelectric elements such as hydroacoustic transducers, and by a possible length of the multi-wire coaxial cable for connecting to the electronics. Wave resistance equalization of the electric cable is realizable.

As opposed to it, the equalization of parameters of the piezoelectric elements improves by matching electrical impedance.

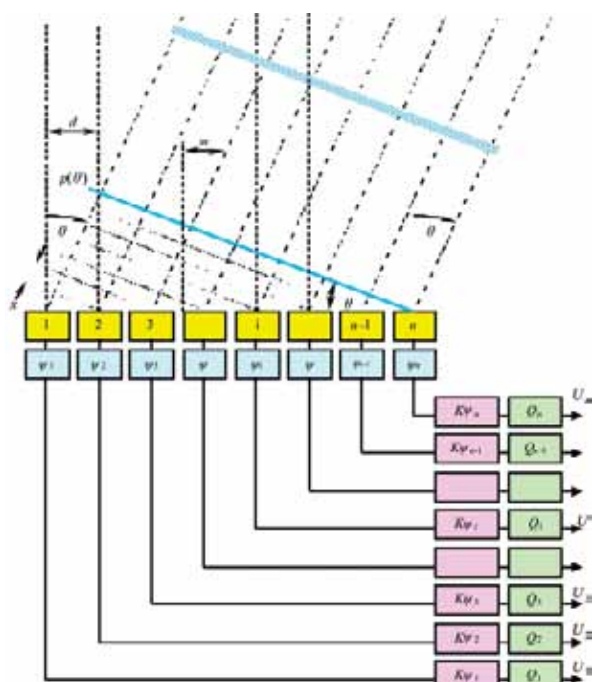

Figure 1 Linear antenna model with an illustration of the phase angle influence of electrical impedance of a piezoelectric stave and the distribution of electric signals for suppressing minor lobes.

Slika 1. Model linijske antene s prikazom utjecaja faznog kuta električne impedancije piezoelektričnih stupaca i raspodjele električnog signala za potiskivanje bočnih latica.

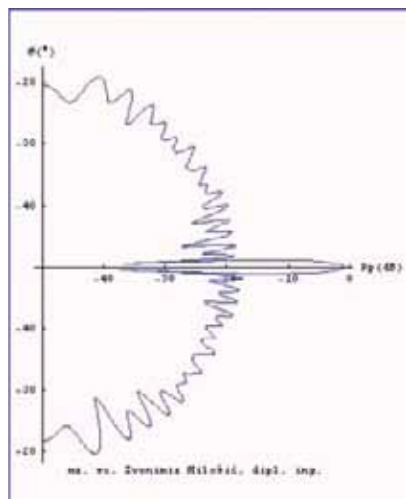
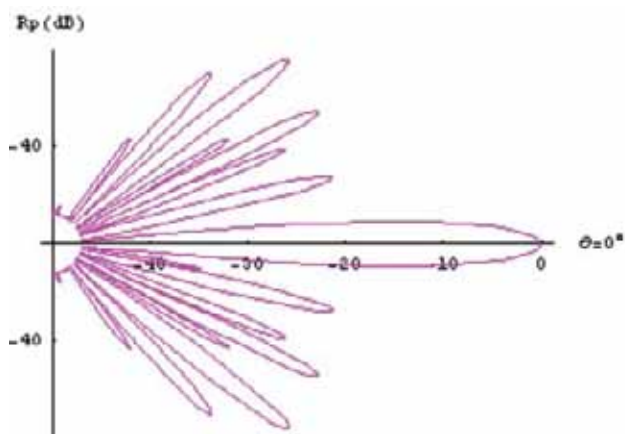

Figure 2 Mathematical simulation of distortion of directivity characteristic of the linear antenna model, with both, a significant influence of the phase angles of electrical impedance of the piezoelectric elements, and an expected level reduction of the suppressed minor lobes.

Slika 2. Matematička simulacija izobličenja karakteristike usmjerenosti modela linijske antene sa znatnim utjecajem faznih kutova električne impedancije piezoelektričnih elemenata i na smanjenje očekivane razine potiskivanja bočnih latica.



mr. sc. Zvonimir Milošić, dipl. ing.

Figure 3 Hydroacoustic cylindrical array model with a horizontally circular base of the element spacing, and vertically linear spacing in the staves.

Slika 3. Usmjerenost antene u horizontalnoj ravni s kružnom osnovom rasporeda elemenata u danom modelu hidroakustičke cilindrične antene.

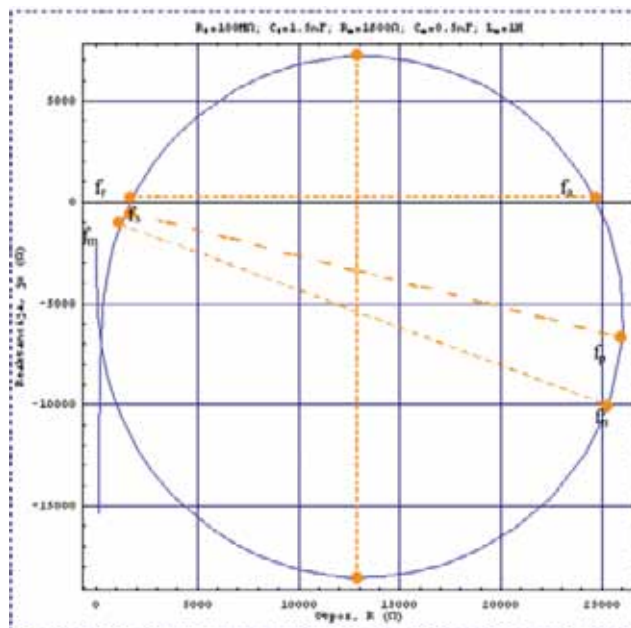

Figure 4 Illustration of electrical impedance of piezoelectric array elements in a complex plain with an outlined position of basic frequencies: f_r , f_a , f_m , f_n , f_s and f_p .

Slika 4. Prikaz električne impedancije piezoelektričnih elemenata antene u kompleksnoj ravni s prikazom položaja šest osnovnih frekvencija: f_r , f_a , f_m , f_n , f_s i f_p .

Figure 1 shows a linear hydroacoustic array model, and Figure 2 simulates distortions of the form of directivity characteristic, as a consequence of the corresponding phase angle dispersion of electrical impedance elements. A correct electrical impedance module matching of each array element implies phase angle matching for achieving good directivity.

In accordance with this, Figure 3 shows simulated directivity pattern of a cylindrical array model, and Figure 4 shows the illustration of electrical impedance of piezoelectric array elements in a complex plane.

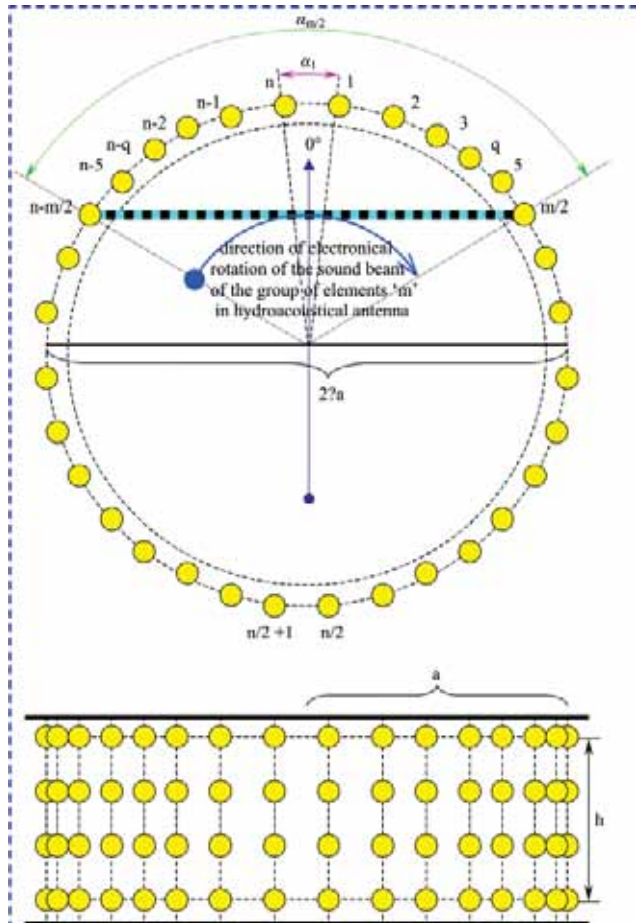

Figure 5 Hydroacoustic cylindrical array model with a horizontally circular base of spacing elements, and vertically linear spacing in the staves.
Slika 5. Model hidroakustičke cilindrične antene s kružnom osnovom rasporeda elemenata u horizontali i linijskim rasporedom po stupcima u vertikali.

In this presentation so far, the directivity characteristic of the hydroacoustic antenna model has shown constant presence and importance of electrical impedance and admittance in de-embedding its parameters. Due to this characteristic, impedance matching of hydroacoustic transducers to the input and output stage of the electronic underwater monitoring system is one of the most important activities in their high-quality coupling. This is especially important in the coupling of hydroacoustic transducers in linear clusters or in some other forms of sonar array systems.

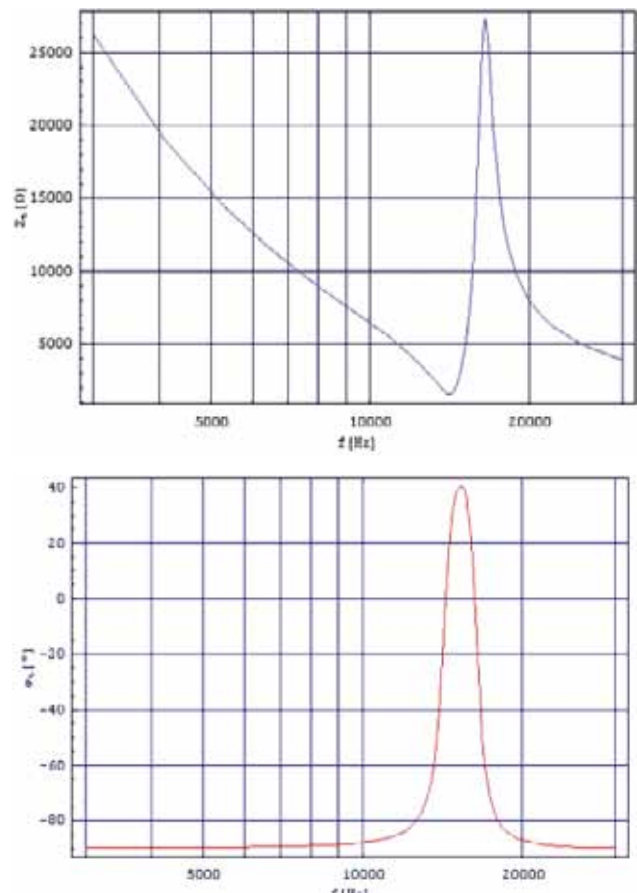

Figure 6 Illustration of module and phase angle of electrical impedance of single piezoelectric array elements in dependence of the frequency.
Slika 6. Prikaz modula i faznog kuta električne impedancije piezoelektričnih elemenata antene u zavisnosti o frekvenciji.

The two most significant couplings for matching electrical impedance of a single array element to the wave resistance of an electric cable, which are analyzed and presented in a special way, are:

1. matching based on a model with an ideal electric transformer and
2. matching with LC transformer.

MATCHING ELECTRICAL IMPEDANCE Z_t TO R_0 BASED ON THE MODEL WITH THE IDEAL ELECTRICAL TRANSFORMER / Prilagođenje električne impedancije Z_t na valni otpor električnog kabela R_0 prema modelu s idealnim električnim transformatorom

Matching electrical impedance of piezoelectric transducer to the electronic circuit, with the electrical transformer, without adding other components, is possible due to its capacitive characteristic in the used band.

The illustration of standard coupling of electric load Z_l of piezoelectric transducer on the output stage according to the ideal electrical transformer model is given in Fig. 7. Applying the two-port network device theory and n-loop-set, n-equation can be generally written as follows in Eq. (1), explained in ref. [9].

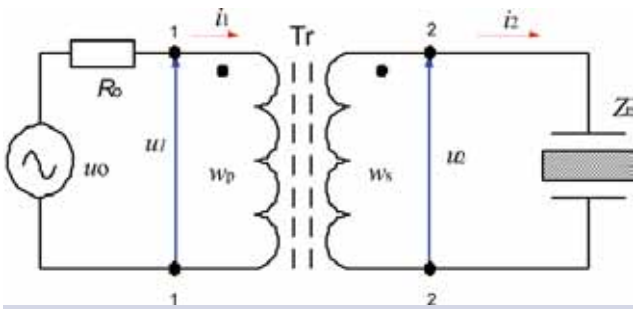

Figure 7 Scheme of piezoelectric transducer coupling on the input stage of transmitter through the ideal electrical transformer module of impedance and phase.
Slika 7. Shema spoja piezoelektričnog pretvarača na izlazni stupanj predajnika preko idealnog električnog transformatora modula impedancije i faze.

$$\left. \begin{aligned} u_1 &= +i_1 Z_{11} - i_2 Z_{12} - i_3 Z_{13} - i_4 Z_{14} - i_5 Z_{15} - \dots - i_n Z_{1n} \\ -u_2 &= -i_1 Z_{21} + i_2 Z_{22} - i_3 Z_{23} - i_4 Z_{24} - i_5 Z_{25} - \dots - i_n Z_{2n} \\ 0 &= -i_1 Z_{31} - i_2 Z_{32} + i_3 Z_{33} - i_4 Z_{34} - i_5 Z_{35} - \dots - i_n Z_{3n} \\ 0 &= -i_1 Z_{41} - i_2 Z_{42} - i_3 Z_{43} + i_4 Z_{44} - i_5 Z_{45} - \dots - i_n Z_{4n} \\ 0 &= -i_1 Z_{51} - i_2 Z_{52} - i_3 Z_{53} - i_4 Z_{54} + i_5 Z_{55} - \dots - i_n Z_{5n} \\ &\dots \\ &\dots \\ &\dots \\ &\dots \\ &\dots \\ 0 &= -i_1 Z_{n1} - i_2 Z_{n2} - i_3 Z_{n3} - i_4 Z_{n4} - i_5 Z_{n5} - \dots + i_n Z_{nn} \end{aligned} \right\} \quad (1)$$

Applying these equations to the T four-pole with two loops, according to Figure 8, it can be written that,

$$\left. \begin{aligned} u_1 &= i_1 (Z_1 + Z_3) - i_2 Z_3 \\ 0 &= -i_1 Z_3 + i_2 (Z_2 + Z_3 + Z_l) \\ u_2 &= i_2 Z_l \end{aligned} \right\} \quad (2)$$

Using the known form of solving equations by means of determinants we have

$$\Delta = \begin{vmatrix} Z_1 + Z_3 & -Z_3 \\ -Z_3 & Z_2 + Z_3 + Z_l \end{vmatrix} = (Z_1 + Z_3) \cdot (Z_2 + Z_3 + Z_l) - Z_3^2 \quad (3)$$

$$\Delta_1 = \begin{vmatrix} u_1 & -Z_3 \\ 0 & Z_2 + Z_3 + Z_l \end{vmatrix} = u_1 \cdot (Z_2 + Z_3 + Z_l) \quad (4)$$

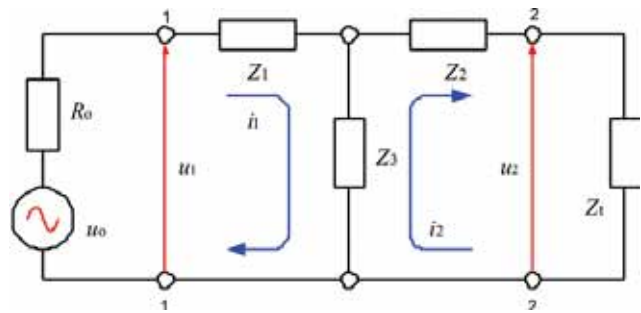

Figure 8 Application of four-pole device theory on the coupling of the ideal electrical transformer as a circuit for matching electrical impedance Z_l and phase angle ψ_l .
Slika 8. Primjena teorije četveropola na spoj idealnog električnog transformatora kao sklopa za prilagođenje modula električne impedancije Z_l i faznog kuta ψ_l .

so that the result for electric current i_1 is given as

$$i_1 = \frac{\Delta_1}{\Delta} = \frac{u_1 \cdot (Z_2 + Z_3 + Z_l)}{Z_1 Z_2 + Z_1 Z_3 + Z_1 Z_l + Z_2 Z_3 + Z_3^2 + Z_3 Z_l - Z_3^2}$$

$$i_1 = u_1 \cdot \frac{(Z_2 + Z_3 + Z_l)}{(Z_1 + Z_3) \cdot (Z_2 + Z_3 + Z_l) - Z_3^2} \quad (5)$$

Since the input impedance at the electrical terminals 1-1 is defined by the relation between the voltage within the terminals u_1 and current i_1 , we have

$$Z_{in} = \frac{u_1}{i_1} = \frac{(Z_1 + Z_3) \cdot (Z_2 + Z_3 + Z_l) - Z_3^2}{Z_2 + Z_3 + Z_l} \quad Z_{in} = Z_1 + Z_3 - \frac{Z_3^2}{Z_2 + Z_3 + Z_l} \quad (6)$$

Resulting to the four-pole theory we have

$$\left. \begin{aligned} Z_1 &= Z_{11} - Z_{12} \\ Z_2 &= Z_{22} - Z_{21} \\ Z_3 &= Z_{12} = Z_{21} \end{aligned} \right\} \quad (7)$$

If the values from Eq. (7) are inserted into Eq. (6), the input electrical impedance is gained

$$Z_{in} = Z_{11} - Z_{12} + Z_{12} - \frac{Z_{12}^2}{Z_{22} - Z_{21} + Z_{21} + Z_1}$$

and finally

$$Z_{in} = Z_{11} - \frac{Z_{12}^2}{Z_{22} + Z_1} \quad (8)$$

in which is:

$Z_{11}(\Omega)$, $Z_{12}(\Omega)$, $Z_{22}(\Omega)$ —electrical impedance in the four-pole theory,

$k(1)$ —coefficient of electrical connection between primary and secondary of the ideal transformer. It can be assumed that ceramic ferrite cores have a minimal scattering of magnetic field lines. In that case we take $k=1$,

$L_p(H)$ –inductance of the primary of the ideal electrical transformer,

$x_p(\Omega)$ –reactance of the primary of the ideal electrical transformer, $x_p = \omega L_p$,

$L_s(H)$ –inductance of the of the secondary of the ideal electrical transformer,

$x_s(\Omega)$ –electrical reactance of the secondary of the ideal electrical transformer, $x_s = \omega L_s$,

$M(H)$ –mutual inductance of the ideal electrical transformer,

$x_M(\Omega)$ –electrical reactance of the mutual inductance of the ideal electrical transformer,

$$x_M = \omega M, \quad x_M^2 = x_p \cdot x_s$$

ω (rad/s)-circular frequency, $\omega = 2\pi f$,

If now Z parameter relations are applied, which are valid for T four-pole in the case of an ideal electrical transformer, as shown in Eqs. (9)

$$\left. \begin{aligned} Z_{11} &= jx_p = j\omega L_p \\ Z_{12} &= Z_{21} = jx_M = j\omega M \rightarrow Z_{12}^2 = j^2 x_M^2 = -x_M^2 \\ Z_{22} &= jx_s = j\omega L_s \\ k &= \frac{M}{\sqrt{L_p L_s}} = 1 \rightarrow M^2 = L_p \cdot L_s \rightarrow x_M^2 = x_p \cdot x_s \end{aligned} \right\} \quad (9)$$

and included in Eq. (8) we have,

$$Z_{in} = jx_p - \frac{-x_M^2}{jx_s + R_t + jx_t} = jx_p + \frac{x_M^2}{R_t + j(x_s + x_t)}$$

If the reactance of the mutual inductance x_M is expressed with the primary x_p reactance and the secondary x_s reactance, we get

$$Z_{in} = \frac{jx_p R_t - x_p x_s - x_p x_t + x_M^2}{R_t + j(x_s + x_t)}$$

which finally results in a complex input impedance value, as in the expression

$$Z_{in} = \frac{x_p x_s R_t}{R_t^2 + (x_s + x_t)^2} + j \frac{x_p (R_t^2 + x_s x_t + x_t^2)}{R_t^2 + (x_s + x_t)^2} \quad (10)$$

It results in the resistance values of the real and imaginary part of electrical impedance

$$R_{in} = \frac{x_p x_s R_t}{R_t^2 + (x_s + x_t)^2} \quad (11)$$

$$x_{in} = \frac{x_p (R_t^2 + x_s x_t + x_t^2)}{R_t^2 + (x_s + x_t)^2} \quad (12)$$

The de-embending the turn number in both the secondary and primary of electrical transformer / *Određivanje broja zavoja u sekundaru i primaru električnog transformatora*

In case of electric matching, the resistance of hydroacoustic transducer equals that of an electrical signal generator or the wave resistance of the cable. Besides that condition, we have

$$R_{in} = R_0 \quad (13)$$

Simultaneously, the reactive component value of the electrical input impedance must be zero. From the condition $x_{in} = 0$ we have that the only second factor in the fraction numerator Eq. (12) has to be zero, and we write

$$R_t^2 + x_s x_t + x_t^2 = 0$$

that is

$$x_s x_t = -(R_t^2 + x_t^2) / x_t$$

$$x_s = -\frac{|Z_t|^2}{x_t} \quad (14)$$

For fulfilling the condition above, the character of the reactance x_t in the Eq. (14) is very important. In order to have a positive value on the right side of this equation, as on the left one, the load reactance x_t must be negative. A negative reactance value in the given working band may have only transducers with a capacitive characteristic, such as many piezoelectric transducers. Therefore, we have to bear in mind, that in a mathematical sense, by inserting negative values into Eq. (14) we eliminate the minus sign on the right side, in front of the fraction.

In this context, a capacitive index mark for the reactive load resistance should be introduced, as a constant warning about its characteristic, thus we write

$$x_t = -x_{tc} \quad (15)$$

which means that the phase angle should be $\psi_t < 0$.

Now the Eq. (14) changes to a form which is usable for a further development.

$$x_s = \frac{R_t^2 + x_{tc}^2}{|x_{tc}|} = \frac{|Z_t|^2}{|x_{tc}|} \quad (16)$$

The value x_s on the upper left equation side represents the inductive resistance of the transformer primary coil. When applying ferrite core for manufacturing the transformer we can use its A_L factor as a manufacturer's fact to compute the inductance according to the manufacturer's recipe as follows

$$\begin{aligned} L_s &= A_L W_s^2 \text{ that is} \\ x_s &= \omega L_s = \omega A_L W_s^2 \end{aligned} \quad (17)$$

Substituting the expression x_s from Eq. (17) to Eq. (16) without the minus sign on the right side, we have, that the coil number in the secondary is de-embedded according to

$$w_s = \frac{|Z_t|}{\sqrt{\omega A_L \cdot |x_{tc}|}} \quad (18)$$

By introducing the phase angle ψ_t of the capacitive electrical load impedance $Z_{tc} = |Z_{tc}| \cdot e^{i\psi}$, a more complex Eq. (18) is gained for de-embedding the turn number in the secondary of the real electrical transformer from the load phase angle as follows Eq. (19)

$$w_s = \sqrt{\frac{|Z_{tc}|}{\omega A_L \cdot |\sin \psi_{tc}|}} = \sqrt{\frac{|Z_{tc}|}{2\pi f A_L} \cdot \frac{\sqrt{1 + \tan^2 \psi_{tc}}}{|\tan \psi_{tc}|}} \quad (19)$$

where we have

w_s (turns)–turn number in the secondary of the real electrical transformer gained by the ideal transformer model,

A_L (nH/turns²)–the factor of pulverized ferrite cores; basic unit is «nano Henry according to the turn number squared», is given as a manufacturer's information in the ferrite core production catalogues,

$|Z_t|$ (Ω)–module of the electrical impedance load, which is gained by measurements in the hydroacoustic laboratory, and is expressed by a complex form,

ψ_{tc} ($^\circ$), (rad)–phase angle of capacitive load of electrical impedance, which, according to the given formula, influences the size of the turn number in the secondary of the electrical transformer with the remark and condition that

$$\psi_t < 0$$

f (Hz)–electronic system working frequency, where $\omega = 2\pi f$.

At the closure of this part of analyzing the application of an ideal transformer model, it should be stated that the turn number in the secondary is de-embedded by the module and the phase angle of the load impedance in the defined band, disregarding the primary. On the other hand, parallel to the voltage transformation of the electrical signal we have a transformation of the load electrical impedance on the side of the primary of the transformer.

The de-embedding of the turns in the primary of the electrical transformer is based on both the condition Eq. (13) and the development of the Eq. (11). According to this, we have

$$R_0 = \frac{x_p x_s R_t}{R_t^2 + (x_s + x_t)^2} \quad \text{and what yield}$$

$$R_0 R_t^2 + R_0 x_s^2 + 2x_t x_s R_0 + x_t^2 R_0 - R_t x_p x_s = 0$$

With the de-embedded condition in Eq. (15) and x_s from Eq. (14) we gain

$$R_0 (R_t^2 + x_t^2) - R_0 \cdot \frac{Z_t^4}{x_t^2} - 2R_0 x_t \cdot \frac{Z_t^2}{x_t} + R_t x_p \cdot \frac{Z_t^2}{x_t} = 0$$

that is

$$R_0 Z_t^2 - R_0 x_t^2 + R_t x_p x_t = 0$$

and since $R_t^2 = Z_t^2 - x_t^2$ we have that is

$$x_p = - \frac{R_0 \cdot R_t}{x_t} \quad (20)$$

If now the mentioned condition Eq. (15) is taken into consideration, which is valid for the whole electrical transformer, the minus sign disappears due to the capacitive characteristic of the load, so in accordance to the model of applying ferrite cores, on the working frequency we have

$$w_p = \sqrt{\frac{R_0 \cdot R_t}{A_L \omega \cdot x_t}} \quad \text{and finally}$$

$$w_p = \sqrt{\frac{R_0}{A_L \omega \cdot |\tan \psi_{tc}|}} = \sqrt{\frac{R_0}{2\pi f A_L \cdot |\tan \psi_{tc}|}} \quad (21)$$

where is

w_p (turns)–turn number in the primary of the real electrical transformer gained on the ideal transformer model,

R_0 (Ω)–wave resistance of electric cable, which couples the hydroacoustic antenna and the electronic system,

f (Hz)–signal frequency in the matching system.

The de-embedding of the turn number in the primary of the real electrical transformer, which is conceived on the ideal transformer model, according to Eq. (21), shows a large phase angle influence ψ_t of electrical impedance of the hydroacoustic transducer as an electrical load and that is because of its characteristic linear change of the tangens function which is much stronger than the linear one.

On the other hand, it is worth taking a look at the way how the secondary and primary coil number depend on the phase angle of electrical impedance. By establishing a relationship between Eq. (19) and Eq. (21) we have

$$\left(\frac{w_s}{w_p}\right)^2 = \frac{|Z_t|^2}{R_0 R_t} = \frac{|Z_t|}{R_0} \cdot \frac{|Z_t|}{R_t}$$

$$\left(\frac{w_s}{w_p}\right)^2 = \frac{Z_t}{R_0} \cdot \frac{1}{\cos^2 \psi_t} \quad (22)$$

that is, if its real value is used, instead of the impedance module, we gain

$$\left(\frac{w_s}{w_p}\right)^2 = \frac{R_t}{R_0} \cdot \frac{1}{\cos^2 \psi_t} \quad (23)$$

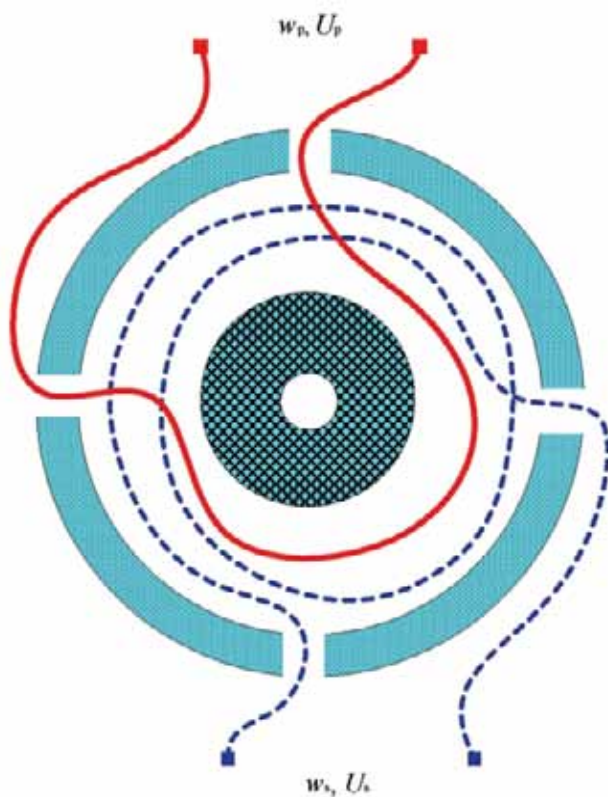

Figure 9 Illustration of the turn spacing with the coiling conduct and the decimal value of the turn on the four-slot ferrite core.

Slika 9. Prikaz smještaja zavoja s načinom namatanja i decimalnim iznosom zavoja na feritnoj jezgri s četiri proreza (šlica)

Expressions (22) and (23) show a very significant and specific influence on defining the square ratio of the primary and secondary of the electrical transformer. A significant influence is due to the fact that the second

factor with the $\cos \psi_{tc}$ function might be larger than the resistance ratio. This is specific because, despite of the fact that we know the turn ratio, we cannot arbitrarily take the coil value w_s or w_p .

Here, it should be emphasized, that the coil number, both of the secondary w_s and primary w_p is strictly de-embedded by load parameters. Discrepancy between the computed values of the turn numbers and the obtained is unwanted. The accordance between the computed values of the turn number and the obtained is gained by using multi-slot ceramic cores, if possible, as in Figure 9.

Namely, in practice the possibility is encountered that the turn number, in both the primary and secondary, is small (e.g. less than 10), so that the mistake of rounding up to a full turn number during coiling might be huge. Therefore, Figure 9 illustration shows graphically how $\frac{3}{4}$ turns of the primary and $1\frac{1}{4}$ turns of the secondary are coiled.

Phase angle influence analysis of electrical impedance of hydroacoustic transducers as a load on the phase angle size at the input terminals of the electrical transformer / *Analiza utjecaja faznog kuta električne impedancije hidroakustičkog pretvarača kao tereta na veličinu faznog kuta na ulaznim stezaljkama električnog transformatora*

The phase angle size on the terminals of the primary of electrical transformer as input terminals at one part of hydroacoustic transducer is especially important for applying array systems. Too large value distortions of the phase angle of the hydroacoustic transducer on the primary, as well as, too large separate values might lead to incorrigible distortions of the beam pattern characteristic of the array system. Due to this fact, the importance of this analysis is significant because, indirectly it is reduced to a discussion about false goals and a directivity DI index change of a hydroacoustic antenna in the monitoring system.

Using formulas (11) and (12) we can write that

$$\tan \psi_{in} = \frac{x_m}{R_m} = \frac{x_p(R_t^2 + x_s x_t + x_t^2)}{x_p x_s R_t} = \frac{R_t^2 + x_s x_t + x_t^2}{x_s R_t} \quad (24)$$

By developing this expression and remarking that the phase angle is $\psi_t < 0$, load has capacitive characteristic, we have

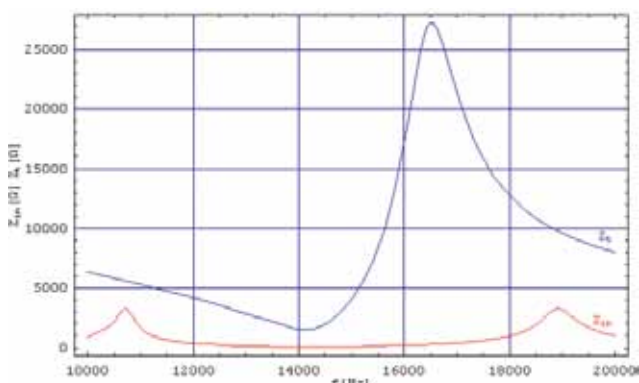

Figure 10 Graphical illustration of the dependence of both the input electrical impedance module Z_{in} and load impedance Z_t on the frequency in the state of matching electrical impedance load to the electric system $R_0=50\Omega$

Slika 10. Grafički prikaz ovisnosti modula ulazne električne impedancije Z_{in} i impedancije tereta Z_t o frekvenciji u stanju prilagođenja električne impedancije tereta na elektronički sustav $R_0=50\Omega$

$$\tan\psi_{in} = \frac{R_t^2 + x_s x_t + x_t^2}{x_s R_t}$$

$$\tan\psi_{in} = \tan\psi_t + \frac{Z_t}{2\pi f L_s w_s^2} \cdot \frac{1}{\cos\psi_t} \quad (25)$$

then is,

$$\tan\psi_{in} = \tan\psi_t + \frac{R_t}{2\pi f L_s w_s^2} \cdot \frac{1}{\cos^2\psi_t} \quad (26)$$

Finally, it is worth mentioning that the Eqs. (25) and (26) are valid with already mentioned condition of the capacitive load, whose phase angle is $\psi_t < 0$, so that the tangent of angle is negative, and the phase angle at the working frequency f_0 is, as expected, $\psi_t = 0$.

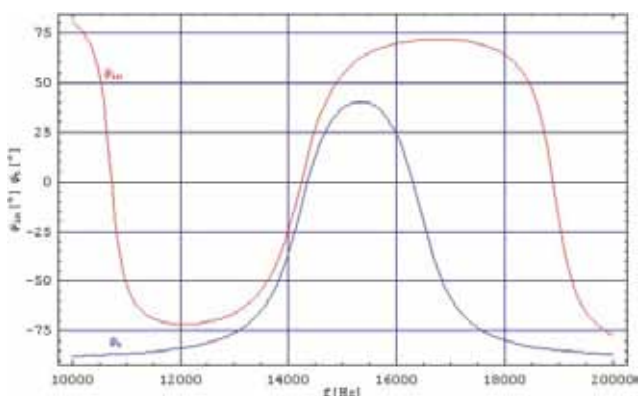

Figure 11 Graphical illustration of the dependence of phase angle of the input electrical impedance ψ_{in} on the frequency in the state of matching electrical impedance of the piezoelectric load Z_t to $R_0=50\Omega$. It should be stressed, that the module and phase angle of the electrical impedance change with the frequency as in Figure 6.

Slika 11. Grafički prikaz zavisnosti faznog kuta ulazne električne impedancije ψ_{in} o frekvenciji u stanju prilagođenja električne impedancije piezoelektričnog tereta Z_t na $R_0=50\Omega$, uz napomenu da se modul i fazni kut električne impedancije mijenjaju s frekvencijom za spoj električnog analogona kao na slici 6.

If the expression for the turn number is inserted into the secondary w_s , at the working frequency in Eq. (25) with a further development, we get

$$\tan\psi_{in} = \tan\psi_t + \frac{Z_t}{Z_{t0}} \cdot \frac{\sin\psi_{t0}}{\cos\psi_t} \cdot \frac{f_0}{f} \quad (27)$$

If the already used facts from the impedance analysis of hydroacoustic transducer are applied in the Eq. (25), we gain graphical illustrations in Figures 10 and 11 which show the conduct of the electrical impedance module Z_{in} and Z_t , as well as the conduct of the phase angle ψ_{in} and ψ_t being matched to $R_0=50\Omega$.

where we have:

$Z_{in}(\Omega)$ —input electrical impedance at the primary of the electrical transformer at a frequency f ,

$\psi_{in}(\text{°})$ —phase angle size at the input to the electrical transformer at a frequency f ,

$Z_t(\Omega)$ —electrical impedance module of the piezoelectric load, which is coupled to the secondary of the matching transformer at a arbitrarily freq. f ,

$f_0(\text{Hz})$ —working frequency of the signal in the matching system, where matching is performed, and where the number of primary and secondary turns is de-embedded,

$Z_{t0}(\Omega)$ —electrical impedance module of the piezoelectric load, which is coupled to the secondary of the matching transformer at a working frequency f_0 ,

$\psi_t(\text{°})$ —phase angle size of the piezoelectric load Z_t at the frequency f ,

$$\psi_t = \arccos(R_t/Z_t)$$

$\psi_{t0}(\text{°})$ —phase angle size of the piezoelectric load Z_{t0} at the frequency f_0 , which is read from the measurement values or is computed according to the expression

$$\psi_{t0} = \arcsin(x_{t0}/Z_{t0}).$$

MATCHING ELECTRICAL IMPEDANCE Z_T OF THE HYDROACOUSTIC TRANSDUCER TO THE ELECTRIC CABLE WAVE RESISTANCE OF THE ELECTRIC SYSTEM WITH LC TRANSFORMER / Prilagođenje električne impedancije Z_t hidro-akustičkog pretvarača na valni otpor kabela elektroničkog sustava s LC transformatorom

Similar to electrical transformers, matching with LC transformers is conducted because of the corresponding module of the electrical impedance transformation of the hydroacoustic transducer as an electrical load, and because of controlling the phase

angle impedance in the array system at a common base. A complete control of these parameters at the input and output of an electric system enables: on one hand, a complete control of the directivity characteristic of the sonar antenna by azimuth and elevation, and on the other one, the control of suppressing minor lobes both in receiving and transmission.

Therefore, on the terminals 1-1, according to Figure 12, we want to analyze basic conditions and to show solutions for a possible transformation of electrical impedance (module and phase angle) of a single array element, where unification and mutual equality are very important for the proper system functioning of the electronic scanning of the acoustic beam. According to the given coupling, we have, that the input of electrical impedance of a single array element is

$$Z_{in} = jx_L + \frac{-jx_C Z_1}{Z_1 - jx_C}$$

$$Z_m = \frac{R_1 x_L^2 + jR_1^2 x_L + jx_L(x_1 - x_C)^2 - jR_1^2 x_C - jx_L^2 x_C + jx_L x_C^2}{R_1^2 + (x_1 - x_C)^2} \quad (28)$$

where is

$$R_m = \frac{R_1 x_C^2}{R_1^2 + (x_1 - x_C)^2} \quad (29)$$

and

$$x_m = \frac{R_1^2 x_L + x_L x_1^2 - 2x_L x_1 x_C + x_L x_C^2 - R_1^2 x_C - x_1^2 x_C + x_1 x_C^2}{R_1^2 + (x_1 - x_C)^2} \quad (30)$$

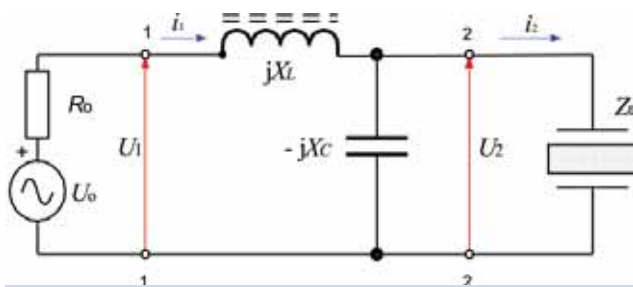

Figure 12 Coupling scheme of LC transformer within the framework of matching hydroacoustic transducers on the output of transmitter of some channel.

Slika 12. Shema spoja LC transformatora u sklopu prilagođenja hidroakustičkog pretvarača na izlaz predajnika nekog kanala.

According to the general matching condition and impedance transformation, we have that

$$R_0 = \frac{R_1 x_C^2}{R_1^2 + (x_1 - x_C)^2}$$

and with a further development, it is

$$(R_1 - R_0) x_C^2 + 2R_0 x_L x_C - R_0 (R_1^2 + x_1^2) = 0 \quad (31)$$

Taking into consideration x_C as an unknown out of which the condenser value should be computed, according to the rule of solving square equations, we have that

$$x_C = \frac{-2R_0 x_1 \pm \sqrt{4R_0^2 |Z_1|^2 \sin^2 \psi_1 - 4R_0 |Z_1|^2 (R_1 - R_0)}}{2(R_1 - R_0)}$$

$$x_C = |Z_1| \cdot \frac{-R_0 \sin \psi_1 \pm \sqrt{R_0 R_1 - R_0^2 (1 - \sin^2 \psi_1)}}{R_1 - R_0}$$

If $x_C = 1/\omega C_{tr}$ is inserted into the upper expression, the expression for the capacitive condenser resistance, we gain that

$$\frac{1}{\omega C_{tr}} = |Z_1| \cdot \frac{-R_0 \sin \psi_1 \pm \sqrt{R_0 R_1 - R_0^2 \cos^2 \psi_1}}{R_1 - R_0}$$

and finally, the condenser capacity in the LC coupling is de-embedded by the expression which has only one real solution, remarking, that the condition exists and that $R_0 < R_1$

$$C_{tr} = \frac{R_1 - R_0}{2\pi f \cdot |Z_1| \cdot (-R_0 \sin \psi_1 + \sqrt{R_0 R_1 - R_0^2 \cos^2 \psi_1})} \quad (32)$$

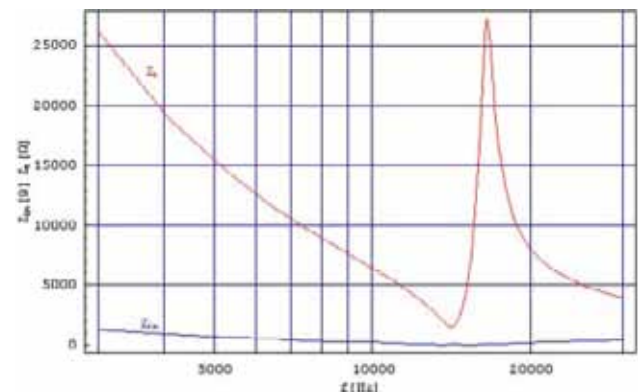

Figure 13 Graphical illustration of the parallel module function of the electrical impedance of the hydroacoustic transducer as load Z_1 , standard model of the substituting electrical values $R_{MR} = 1600\Omega$, $L_M = 0.25H$, $C_M = 0.5nF$ i $C_0 = 1.5nF$; and of the module of the electrical impedance Z_{in} input of the LC transformer, which is matched to $R_0 = 50\Omega$.

Slika 13. Grafički prikaz usporedbe funkcija modula električne impedancije hidroakustičkog pretvarača kao tereta Z_1 , standardnog modela nadomjesnih električnih veličina $R_{MR} = 1600\Omega$, $L_M = 0.25H$, $C_M = 0.5nF$ i $C_0 = 1.5nF$, i modula ulazne električne impedancije Z_{in} LC transformatora koji se prilagođava na $R_0 = 50\Omega$.

From the second condition, we have $x_m = 0$ and then is

$$R_1^2 x_L + x_L x_1^2 - 2x_L x_C x_1 + x_L x_C^2 - R_1^2 x_C - x_C^2 x_1^2 + x_C^2 x_1 = 0$$

and

$$x_L = \frac{|Z_t|^2 x_C - x_t x_C^2}{|Z_t|^2 + x_C^2 - 2x_t x_C}$$

If they are inserted into the expression of the load reactance $x_t = |Z_t| \sin \psi_t$ we have

$$x_L = \frac{|Z_t|^2 x_C - x_C^2 |Z_t| \cdot \sin \psi_t}{|Z_t|^2 + x_C^2 - 2x_C |Z_t| \cdot \sin \psi_t} \quad (33)$$

and since $x_L = 2\pi f L_{tr}$, we have that the inductance is

$$L_{tr} = \frac{1}{2\pi f} \cdot \frac{|Z_t|^2 x_C - x_C^2 |Z_t| \cdot \sin \psi_t}{|Z_t|^2 + x_C^2 - 2x_C |Z_t| \cdot \sin \psi_t} \quad (34)$$

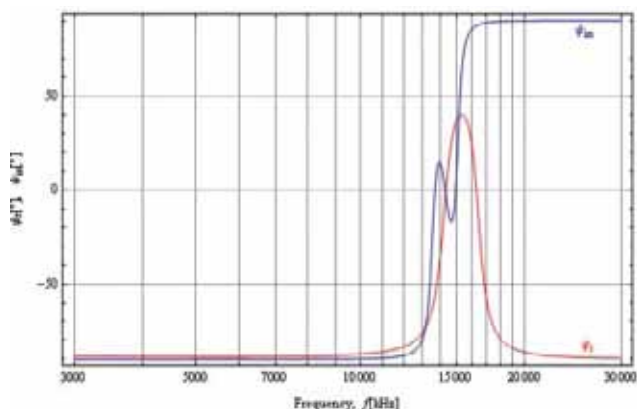

Figure 14 Graphical illustration of the comparison of the phase angle function ψ_t of the electrical impedance of the hydroacoustic transducer as load Z_t , standard model of the substituting electrical values $R_{MR}=1600\Omega$, $L_M=0.25F$, $C_M=0.5nF$ and $C_0=1.5nF$; and of the phase angle ψ_{in} of electrical impedance Z_{in} of the hydroacoustic transducer, which is matched to the wave resistance of electric cable $R_0=50\Omega$.

Slika 14. Grafički prikaz usporedbe funkcija faznog kuta ψ_t električne impedancije hidroakustičkog pretvarača kao tereta Z_t , standardnog modela nadomjesnih električnih veličina $R_{MR}=1600\Omega$, $L_M=0.25H$, $C_M=0.5nF$ i $C_0=1.5nF$, te faznog kuta ψ_{ul} ulazne električne impedancije Z_{ul} LC transformatora koji se prilagođava na valni otpor električnog kabela $R_0=50\Omega$.

CONCLUSIONS / Zaključak

According to the introductory overview of two basic antenna models, with an illustration of the strong negative influence of the dispersion of the phase angle size over array elements on their directivity characteristic, the necessity is pointed out to match their electrical impedance completely. The main part of the article shows special mathematical solutions for the ideal electrical transformer for the practical performance and for a complete electrical impedance matching of the array elements to the wave resistance of

the electric cable for coupling with the input and output parts of electronic circuits of the hydroacoustic system. This shows the possibility to obtain mathematically a complete electrical impedance matching of the piezoelectric elements of the hydroacoustic array, and to obtain conditions for a good array mounting in transceiver channels.

All this has been tested and verified in laboratory, and attested on the hydroacoustic systems and ultrasound medical systems in practice, too.

ACKNOWLEDGMENTS / Zahvale

The author would like to thank Brodarski institut d.o.o. Zagreb, for having made it possible to work on various projects, and to the Ministry of Defense of the Republic of Croatia for their initiative to write articles and also for support in their publication. In accordance with this theory, the final solves in this paper are attested and practically realized at Brodarski institute in Zagreb, and shown in report PQ06-02-000//PS-NC04-166.

Also, a lot of thanks to Hela and Mihael for their support and patience.

REFERENCES / Literatura

1. Aseev, B. P.; *The oscillate circuits*, Svjaziizdat, Moskva 1955, in Russian,
2. Atabekov, G. I.; *The linear electric circuits*, Energija, Moskva, 1966 i 1978, in Russian,
3. Jelaković, Tihomil; *Transformers and dampers*, Tehnička knjiga Zagreb, 1960, in Croatian,
4. Johnson, Walter C.; *Transmission Lines and Networks*, Mc Graw-Hill Kogakusha, Ltd. 1950, Princeton University,
5. LePage, R. Wilbur; *Analysis of Alternating current circuits*, Syracuse University, McGraw-Hill Book Company, Inc., New York 1952,
6. Milošić, Zvonimir; *Matching electrical impedance of hydroacoustic transducers at a stable working frequency*, Elektrotehnika, XXII-1978, No. 3-6, pages 171-173, in Croatian,
7. Milošić, Zvonimir; *Models of de-embedding parameter of hydroacoustic arrays in the underwater monitoring system*, Dissertation, FER Zagreb 2004, in Croatian,
8. Morgan Matroc Limited; *Piezoelectric Ceramics*, Transducer Products Division, Thornhill Southampton, Hampshire SO19 7TG England, 1996,

9. Plohl, Miroslav; *Theory of transmission systems*, Faculty of Electrical Engineering of Zagreb, University of Zagreb, 1966, in Croatian,
10. Prasad, S. Eswar; *Piezoelectric Ceramics*, Product Catalogue, Application Notes, SENSOR, Collingwood, Ontario, Canada, 1995,
11. Ryder, D. John; *Networks, Lines and Fields*, New York, Prentice-Hall, Inc. 1955,
12. SIEMENS; *Ferrites*, Data Book 1986/87, München, Germany,
13. Sverdlin, Mihailovich Grigorii; *The hydroacoustic transducers and antennas*, Sudostroenie, Leningrad, 1980, in Russian,
14. Wolfram Research, Europe Ltd., *MATHEMATICA 4 & 6*, 10 Blenheim Office Park, Lover Road, Long Hanborough, Oxfordshire OX29 8RY, UK; SYSTEMCOM d.o.o., certified reseller for Wolfram Research, Maksimirska 120, 10000 Zagreb, CROATIA, for Microsoft Windows 95/98/NT/2000/XP,
15. Zeveke G., Ionkin P., Netushil A., Strakhov S.; *Analysis and Synthesis of Electric Circuit*, MIR Moscow 1969, 1973, 1979, in Russian.

Rukopis primljen: 27. 10. 2009.

