

RI 9420

**RI 9420**

REPORT OF INVESTIGATIONS/1992

LIBRARY  
SPOKANE RESEARCH CENTER  
RECEIVED

NOV 16 1992

US BUREAU OF MINES  
E. 315 MONTGOMERY AVE.  
SPOKANE, WA 99207

# Teleoperation of a Highwall Mining System

By August J. Kwitowski, Albert L. Brautigam,  
and Michael C. Leigh

UNITED STATES DEPARTMENT OF THE INTERIOR



BUREAU OF MINES

**Mission:** As the Nation's principal conservation agency, the Department of the Interior has responsibility for most of our nationally-owned public lands and natural and cultural resources. This includes fostering wise use of our land and water resources, protecting our fish and wildlife, preserving the environmental and cultural values of our national parks and historical places, and providing for the enjoyment of life through outdoor recreation. The Department assesses our energy and mineral resources and works to assure that their development is in the best interests of all our people. The Department also promotes the goals of the Take Pride in America campaign by encouraging stewardship and citizen responsibility for the public lands and promoting citizen participation in their care. The Department also has a major responsibility for American Indian reservation communities and for people who live in Island Territories under U.S. Administration.

**Report of Investigations 9420**

# **Teleoperation of a Highwall Mining System**

**By August J. Kwitowski, Albert L. Brautigam,  
and Michael C. Leigh**

**UNITED STATES DEPARTMENT OF THE INTERIOR  
Manuel Lujan, Jr., Secretary**

**BUREAU OF MINES  
T S Ary, Director**

**Library of Congress Cataloging in Publication Data:**

**Kwitowski, August J.**

Teleoperation of a highwall mining system / by August J. Kwitowski, Albert L. Brautigam, and Michael C. Leigh.

p. cm. — (Report of investigations; 9420)

Includes bibliographical references (p. 16).

Supt. of Docs. no.: I 28-22:9420.

1. Coal-mining machinery—Automatic control. 2. Coal mines and mining—Electronic equipment. 3. Remote control. I. Brautigam, Albert L. II. Leigh, Michael C. III. Title. IV. Series: Report of investigations (United States. Bureau of Mines); 9420.

TN23.U43. [TN813] 622 S—dc20 [622'.334] 92-6228 CIP

## CONTENTS

	<i>Page</i>
Abstract .....	1
Introduction .....	2
Teleoperated highwall mining system .....	2
Coal extraction .....	3
Coal haulage .....	3
Mainframe structure .....	4
Computer-based teleoperational system .....	4
Control system overview .....	4
Workstation .....	5
Sensor .....	5
Surface evaluation and refinement .....	10
Surface evaluation results .....	13
Predeployment activities .....	13
Field deployment of teleoperated highwall mining system .....	13
Field evaluation results .....	15
Recommendations for improvement .....	15
High-speed data transmission .....	15
Maintainability .....	15
Video system availability .....	15
Conclusions .....	16
References .....	16
Appendix.—Sensory information from mining machine .....	17

## ILLUSTRATIONS

1. Artist's concept of teleoperated highwall mining system .....	3
2. Thin-seam continuous miner modified for teleoperation .....	4
3. Modified continuous haulage system .....	5
4. Ergonomically designed workstation for teleoperator .....	6
5. Sensors arrangement on teleoperated thin-seam continuous miner .....	7
6. Pan-tilt video system .....	7
7. Currents for conveyor haulage conditions .....	8
8. Shape of thin-seam continuous miner oil reservoir .....	9
9. Plot of oil level versus oil volume .....	9
10. Surface-cutting trials .....	10
11. Instrumentation for recording vibration data .....	12
12. Spectral plot of vertical acceleration data during coal cutting .....	12
13. Teleoperated highwall mining system at production site .....	14

## TABLES

1. Analog channel assignments .....	6
2. Average computer delay times .....	11
3. Maximum computer delay times .....	11
4. RMS vibration on Jeffrey mining machine by activity .....	11

### UNIT OF MEASURE ABBREVIATIONS USED IN THIS REPORT

A	ampere	in	inch
°C	degree Celsius	lb	pound
ft	foot	psid	pound per square inch, differential
ft/min	foot per minute	psig	pound per square inch, gauge
gal	gallon	st	short ton
grms	gravity, root mean square	st/min	short ton per minute
hp	horsepower	V ac	volt, alternating current
Hz	hertz		

# TELEOPERATION OF A HIGHWALL MINING SYSTEM

By August J. Kwitowski,<sup>1</sup> Albert L. Brautigam,<sup>2</sup> and Michael C. Leigh<sup>2</sup>

---

## ABSTRACT

The U.S. Bureau of Mines developed and tested a teleoperating system to control a new highwall mining system. A remote operator was provided out-of-sight sensory information and control of coal extraction and haulage equipment. Surface and production testing proved that the teleoperating system supplied the operator with sufficient sensory information to operate the mining system. Details on the teleoperating system provided in this report include (1) sensor selection, (2) a description of the electronic control system, (3) equipment selection and modifications, (4) the positive test results, and (5) recommendations for system improvements.

---

<sup>1</sup>Civil engineer.

<sup>2</sup>Electrical engineer.

Pittsburgh Research Center, U.S. Bureau of Mines, Pittsburgh, PA.

## INTRODUCTION

For mining, remote control usually refers to actuating the functions of a mining machine from a portable, tethered, or radio-linked control box. The operator with the control box is within direct line-of-sight to the mining operations (10 to 50 ft) and receives operational cues directly. A reason that remote control was developed is that, for thin-seam applications, there is normally insufficient space to house the operator and controls in a compartment onboard the machine. Thus, many commercially available remote control systems are associated with thin-seam mining equipment, especially continuous mining machines. Remote control also allows the operation of continuous mining machines for extended (deep) cuts that would otherwise place a machine-based operator under unsupported roof.

Although remote control operators can position themselves to reduce their exposure to dust and noise, they are still subjected to these health hazards associated with the equipment operation. A type of accident associated with tethered and radio remote control is when the equipment operator is crushed between the machine and a rib because of inadvertent actuation of the incorrect tram or discharge boom control.

For this U.S. Bureau of Mines report, teleoperation describes the computer-based, distant control of mining machinery from a protected operator compartment located out of the line-of-sight from the operational site. Thus, sensory information about operating the equipment cannot be obtained directly. Video, sound, and other relevant information are gathered through sensors and are transmitted electronically to the operator's location. The sensory information is conditioned and scaled before being displayed. The teleoperator responds to the information and makes decisions that are initiated by the actuation of control devices (usually switches). These control commands are then electronically transmitted to the machine

being operated, and the appropriate machine functions are carried out.

Teleoperated mining systems will increase the health and safety of mine workers by allowing them to be relocated away from the hazardous areas. This is especially true for face equipment operators, as they are relocated from the zone widely documented as the most hazardous area in all mining—within 25 ft of the working face. Teleoperation also enhances operator comfort.

The Bureau's involvement with teleoperation dates back to 1979, when a study began to explore the feasibility of using the same methodology for thin-seam continuous mining machines as that used in deep, room-and-pillar coal mining. This feasibility study was positive, and in following years, development of a system commenced to the point of designing and fabricating a computer-based control system. At this point, a suitable thin-seam continuous miner was not available for system evaluation. In 1985, an opportunity arose that allowed the teleoperational concept to be evaluated as a subsystem of a cooperater's new highwall mining system. The cooperater, Short Hole System (S.H.S.), Inc., of Morgantown, WV, agreed to supply a new Jeffrey<sup>3</sup> model 102HP mining machine to be extensively modified by the Bureau for teleoperation. Later, it was agreed to use the Bureau's multiple-unit continuous haulage (MUCH) system as part of this new teleoperated highwall mining system (THMS).

Highwall mining involves the recovery of coal reserves from coal seam(s) that outcrop either naturally or from being exposed through earth removal operations, such as strip mining. Typical highwall mining systems are controlled from the bench and have no people underground, and no effort is made to provide active roof control within the mined entry (hole). The mining plan usually involves parallel-driven mined holes with ribs between the holes maintained at some predetermined thickness.

## TELEOPERATED HIGHWALL MINING SYSTEM

Figure 1 shows an artist's conceptual view of the THMS deployed at a production site. The THMS is composed of a wide variety of integrated subsystems and components: (1) a thin-seam continuous miner (TSCM), (2) the MUCH system, (3) a control station, (4) the computer-based teleoperating system, (5) a laser alignment system, and (6) bench-based support equipment. None of the operating personnel are located in the mine entries. The unique design and application of the THMS required that (1) proven components be assembled in original

configurations, (2) prototype equipment, such as the MUCH system, be used, and (3) completely new subsystems and components be developed. Where possible, off-the-shelf components were used to increase reliability.

A goal of the THMS mining plan is to minimize the time that the machinery spends under the highwall by advancing and retracting the equipment as quickly as

<sup>3</sup>Reference to specific products does not imply endorsement by the U.S. Bureau of Mines.



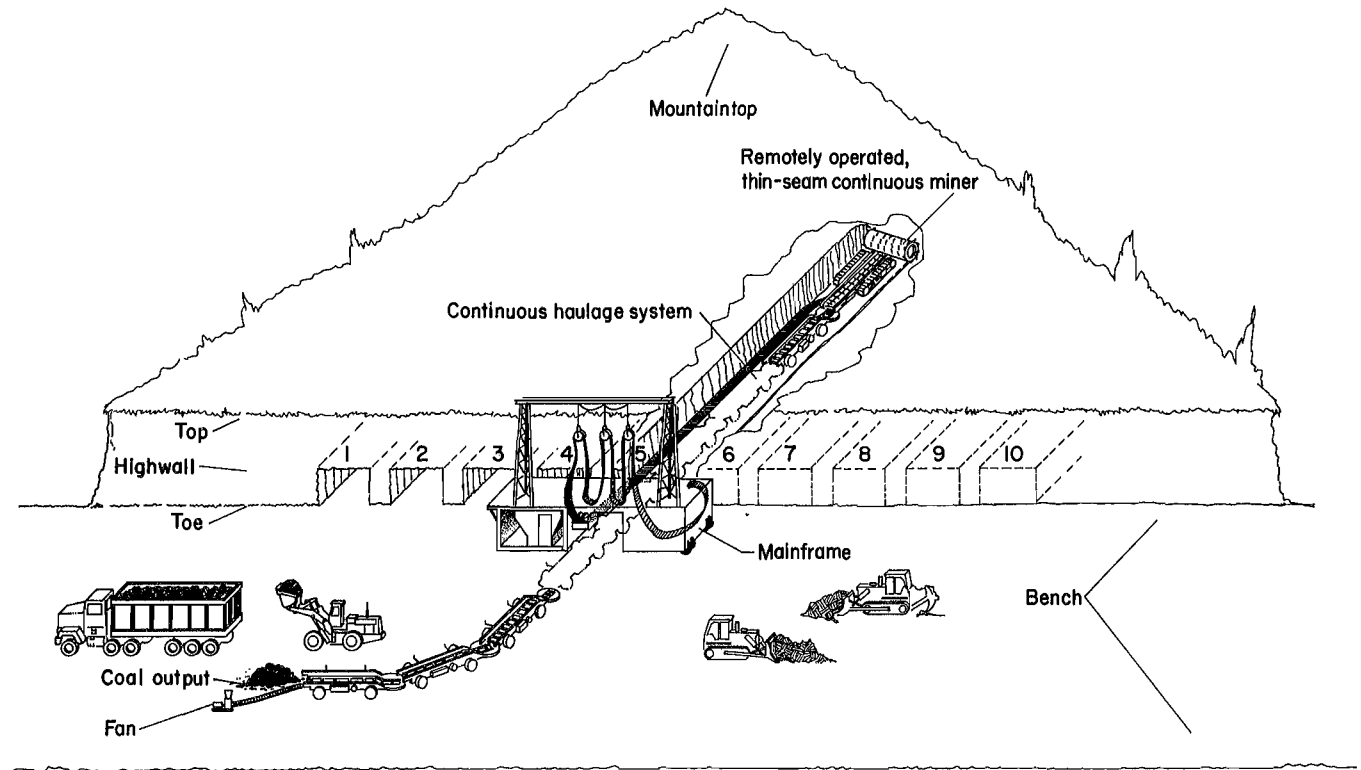

Figure 1.—Artist's concept of teleoperated highwall mining system.

possible. Thus, operation is sustained and no roof supports are installed.

For the THMS, there are no coal-cutting and haulage power losses associated with increased depth of highwall penetration. Thus, a modified version of the THMS is theoretically capable of mining coal over 1,000 ft from the highwall face. The THMS employs a unique, ergonomically designed, operator control station and requires three workers.

### COAL EXTRACTION

Coal is mined and loaded by a Jeffrey model 102HP TSCM heavily modified for teleoperation. The modified TSCM is shown in figure 2. Modifications made by the Bureau included (1) selection, packaging, installation, and wiring of sensors, (2) packaging and installation of three video subsystems, (3) packaging, mounting, and wiring of a remote computer and sensor processing electronics, (4) modification of the electronics mountings and enclosures to damp out destructive vibrations and to prevent infiltration of moisture, (5) invention, design, and installation of a unique, accelerometer-based sound subsystem, and (6) redesign and fabrication of the protective, steel plate machine covers.

Modifications made jointly by the Bureau and the cooperator included (1) adding a heavy strengthening plate for mounting a remote computer enclosure and sheaves for a retrieval subsystem, (2) modifying and replumbing the hydraulic system to add functions and to facilitate maintenance, (3) modifying the brake packs to allow the TSCM to be retrieved in an emergency, and (4) modifying the TSCM conveyor to incorporate an exhausting-type ventilation subsystem.

Modifications made primarily by the cooperator included (1) increasing the widths of the cutting auger and gathering plow from 10 ft to 11 ft 3 in, (2) increasing the length of the tail boom by 10 ft, (3) adding hydraulic jacking assemblies for adjusting the pitch of the TSCM, and (4) adding extendible guides for use during system retraction.

### COAL HAULAGE

For haulage, the THMS employs a modified version of the Bureau's prototype MUCH system (1-2).<sup>4</sup> Modifications made by the Bureau included (1) the design and

<sup>4</sup>Italic numbers in parentheses refer to items in the list of references preceding the appendix at the end of this report.

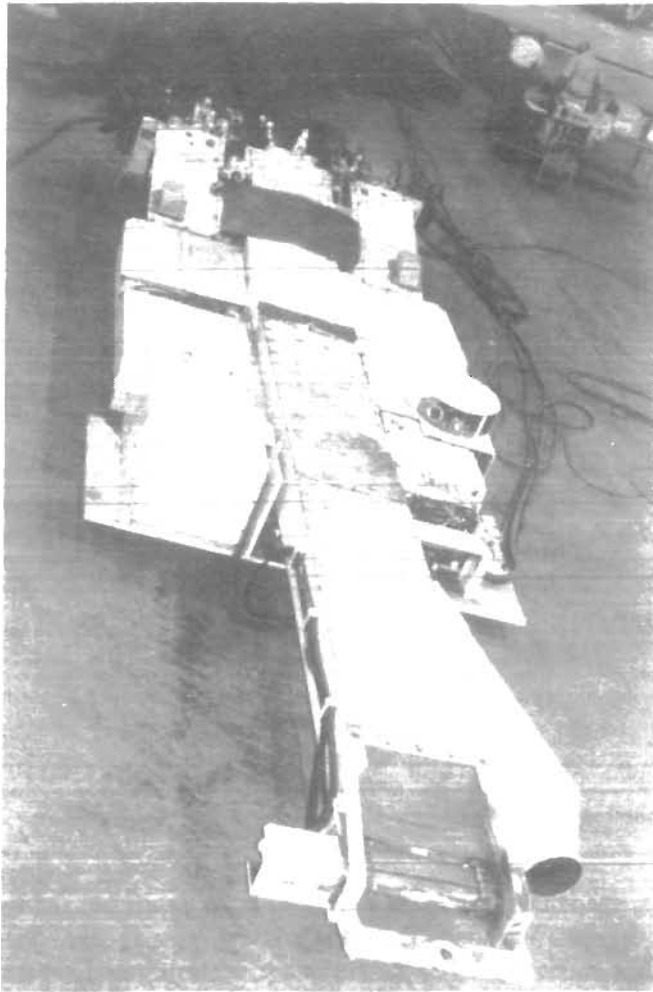

**Figure 2.**—Thin-seam continuous miner modified for teleoperation. (Photo by William H. Lewis, Pittsburgh Research Center.)

fabrication of a unique, semiflexible ventilation subsystem that extends along the 250-ft length of the haulage system (3), (2) the design and installation of a subsystem for monitoring and displaying the individual conveyor motor currents for each of the 13 vehicles, (3) the design, selection, and installation of electrical and mechanical components to allow quick coupling and decoupling of individual vehicles, and (4) rewiring of the electrical system to allow control of the MUCH system by the teleoperator. Jointly, the Bureau and the cooperater devised a cable-handling apparatus to allow the TSCM to advance 10 ft before the MUCH system was required to be advanced. Modifications made primarily by the cooperater included (1) modifying the steering on the lead vehicle to allow it to automatically track the path of the TSCM, (2) lowering the height of the vehicles to allow operation in 48-in seams, and (3) increasing the length of the receiving pan on the

lead vehicle by 5 ft. Figure 3 shows the modified MUCH system deployed at the coal production site.

### MAINFRAME STRUCTURE

The cooperater designed and fabricated a massive, tire-mounted mainframe structure that is situated on the high-wall bench (fig. 1). Among other functions, the mainframe (1) encloses the remote operator's station, (2) supports the structure and operating mechanisms for the "festooning-style" cable-ribbon-handling subsystem, (3) houses electrical distribution equipment, (4) contains hydraulic and winching hardware that allow an extractive force of up to 800,000 lb to be exerted on the THMS inside the extraction entry, (5) encloses a radiator for coolant circulated through the jackets of the auger motors on the TSCM, and (6) mounts the ventilation fan. The Bureau was not directly involved with the mainframe structure. However, care was taken so Bureau THMS subsystems were compatible with the mainframe structure.

### COMPUTER-BASED TELEOPERATIONAL SYSTEM

For the THMS, a single operator controls the TSCM, the major functions of the MUCH haulage system, and some functions of the highwall-based support equipment. The teleoperator is situated at an ergonomically designed workstation within a protective enclosure on the highwall bench (4).

### Control System Overview

Because of the need to run cables and hoses into the entries for power, cooling, and equipment retraction (in case of a roof fall), the use of additional cables for control and sensory information was not considered a significant problem. It was preferable, however, to minimize the number of conductors, and this was done by digital multiplexing of the data.

A network of interconnected computers (master and remote) communicated with each other in the information exchange (5). As many as 48 on-and-off commands could be transmitted to the TSCM, and 16 analog channels of information could be transmitted to the teleoperator's station. The twisted pair of electrical conductors between computers was time-shared among the data channels, and the information was transmitted as binary codes.

The other twisted pair conductors that existed between the control station and mining machine were used for functions such as emergency stop interlock and audio information. Coaxial conductors in the data cables carried two color and one black and white (B&W) video channel from the mining machine.

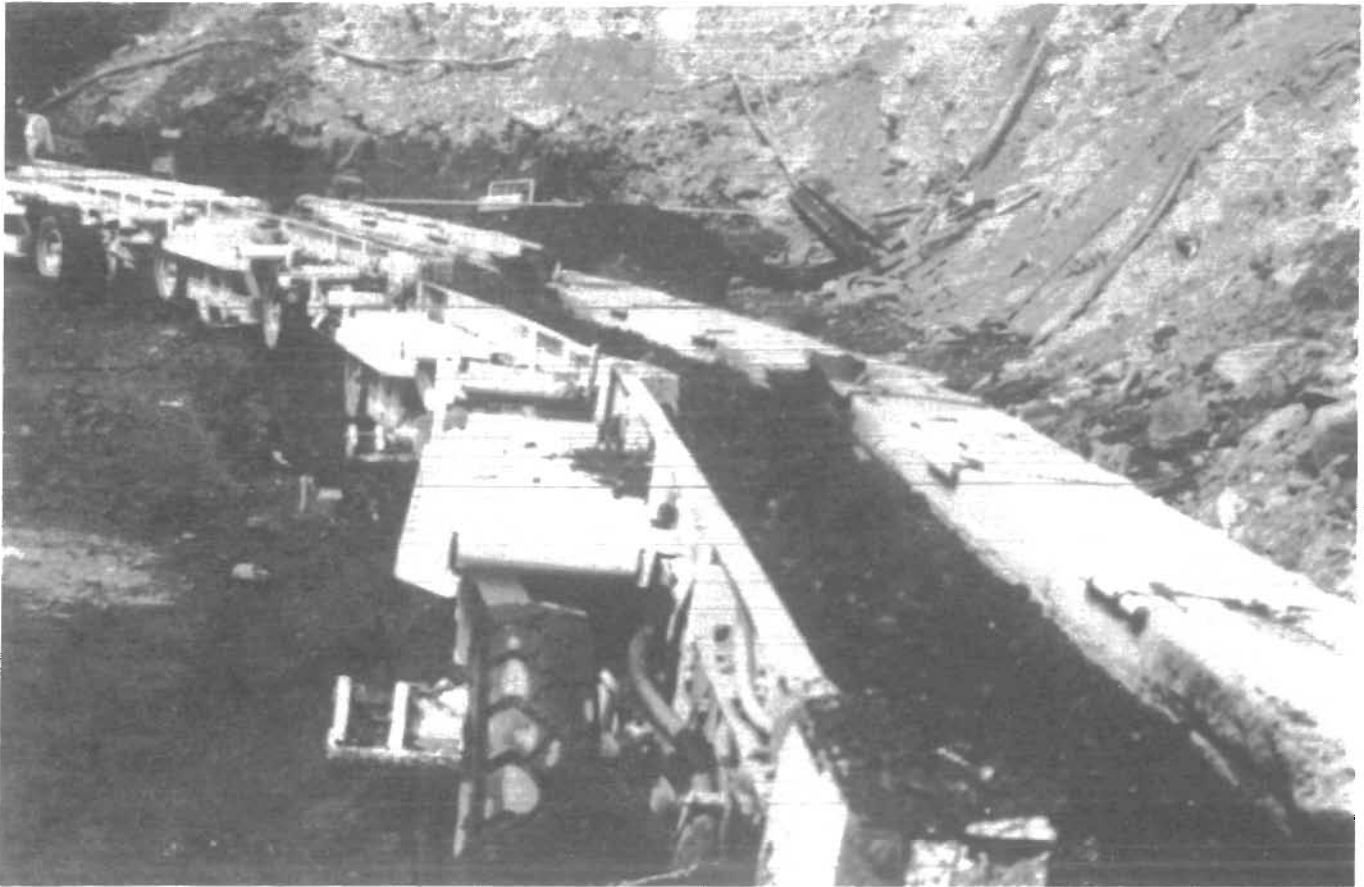

Figure 3.—Modified continuous haulage system.

### Workstation

Key elements of the workstation design were to (1) allow the operator to keep all control and monitoring functions within easy reach and view, (2) keep the operator comfortable for long periods, while mining the highwall entry, and (3) provide some flexibility for the operator to change seating and body positions, while still maintaining operational capabilities.

As shown in figure 4, the operator sits in a semireclined position using a special task chair with adjustable back and headrest. Color-coded light emitting diode (LED) bar graph displays with digital readouts present information originating from the TSCM sensors. The displays are mounted in an adjustable, swing-away console mounted in front of the teleoperator. This console also contains controls for the bench-based ancillary equipment. Main TSCM operational controls, used about 80% of the time during mining, are located in a small, handheld module suitable for use by either a right- or a left-handed operator. Secondary TSCM and other controls, including camera adjustment, are placed in a module located next to

the right armrest of the task chair. Dual 19-in color video monitors and haulage conveyor motor current monitors are housed in a custom cabinet located at the optimum viewing distance from the operator's eye position. Stereo face sounds originate from a unique, accelerometer-based sound system on the TSCM. The operator is given the option of listening to the sounds through either a pair of speakers or headphones.

### Sensor

The ability to teleoperate the THMS is related to the operator's knowledge of vital equipment and site parameters. Initially, a list of 12 parameters, shown in the appendix, were identified as being significant to the operation of the TSCM. During system design, some were added and others deleted. Eventually, a total of 16 analog data channels, as listed in table 1, were installed, plus 3 video, and 2 accelerometer-based audio channels. Figure 5 shows the location of each sensor on the mining machine. Additionally, the chain conveyor motor current for each of the 13 MUCH units was monitored and displayed. The



Figure 4.—Ergonomically designed workstation for teleoperator. (Photo by William H. Lewis, Pittsburgh Research Center.)

following discusses the salient features of the video system, mining machine and haulage system operational conditions, operator's perception of mining machine and work-site conditions, and the display console.

#### Video System

The operator's primary means of monitoring the THMS is through a multicamera, closed-circuit video system. The operator is provided with information on the (1) conditions at the working face, (2) position of the cutting head relative to the coal-roof interface, (3) flow of cut coal along the conveyors, and (4) position of the TSCM relative to a laser alignment beam.

Three separate video systems are mounted on the TSCM. One color video system is located above and forward of the remote computer enclosure and provides a fixed overall view of the face area and cutting auger. A second color video system is located on the right fender of the mining machine; it includes a hydraulically driven pan and tilt mechanism. The operator can position this system

to an area of interest, such as the haulage system or laser target. It also serves as a backup for the main face camera, in the event of failure. Both color video systems consist of a compact, solid-state, color camera coupled to a motorized zoom lens with adjustable iris, focus, and zoom. A third B&W video system is located on the underside of the machine mainframe and provides a view of the mining machine's left track and surrounding floor area. The B&W camera is much smaller than the color cameras and offers improved resolution and low light sensitivity.

Table 1.—Analog channel assignments

Channel	Parameter	Sensor type	Range
1 . . . . .	Oil temperature.	Type J thermocouple.	Minus 100° to 300° C.
2 . . . . .	Pump motor temperature.	.. do . . . . .	Do.
3 . . . . .	Left auger motor temperature.	.. do . . . . .	Do.
4 . . . . .	Right auger motor temperature.	.. do . . . . .	Do.
5 . . . . .	Pump motor current.	Toroid current transformer.	0 to 200 A.
6 . . . . .	Left auger motor current.	.. do . . . . .	0 to 300 A.
7 . . . . .	Right auger motor current.	.. do . . . . .	Do.
8 . . . . .	Mining machine roll attitude.	Electrolytic fluid inclinometer.	Minus 30° to 30°.
9 . . . . .	Mining machine pitch attitude.	.. do . . . . .	Do.
10 . . . . .	Methane level.	Commercial unit with analog output.	0 to 5%.
11 . . . . .	Filter differential pressure.	Strain gage bridge.	0 to 100 psid.
12 . . . . .	Oil level . . .	Radio frequency-capacitance probe.	0 to 15 in.
13 . . . . .	Face distance.	Sonar (ultrasonic).	0 to 50 in.
14 . . . . .	Sump distance.	Magnetostrictive linear displacement.	0 to 20 in.
15 . . . . .	Conveyor boom height.	Electrolytic fluid inclinometer.	0 to 50 in.
16 . . . . .	Auger boom height.	Rotary variable differential transformer.	Minus 5 to 55 in.

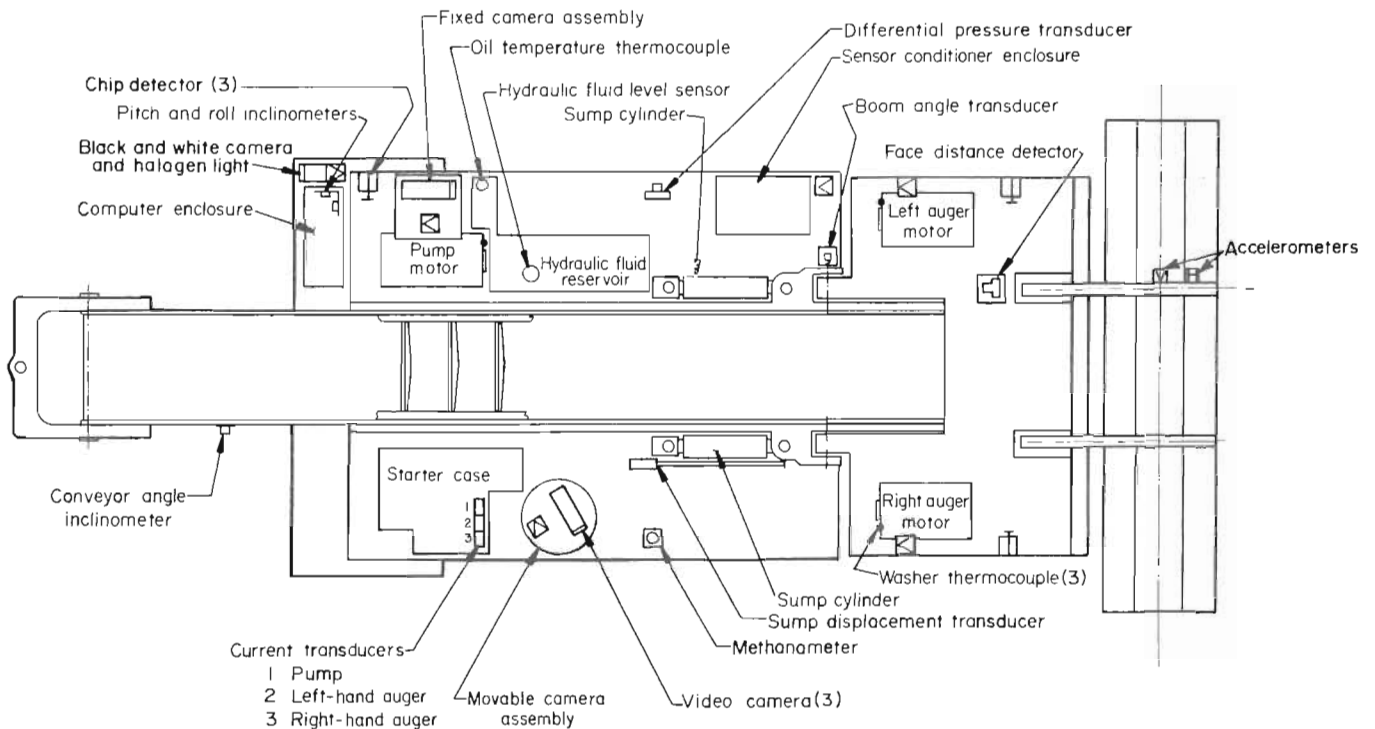

Figure 5.—Sensors arrangement on teleoperated thin-seam continuous miner.

Each camera with lens is housed in a custom-designed, explosion-proof enclosure with an antireflection-coated optical window. The enclosures were designed to be waterproof and dustproof. Special considerations were given to shock mounting the video components in the enclosure and to shock and vibration isolating the enclosure from the machine mainframe. A continuous flow of air is passed over the front surface of the optical window. This prevents dust from accumulating on the window and deteriorating the video system resolution.

Illumination for the video systems consists of five compact tungsten halogen headlamps. Two headlamps are mounted on either side of the cutting-head boom and are aimed at the face. The other three are dedicated to the video systems and are mounted adjacent to them. The lights are aimed parallel to the axis of the cameras; in the case of the movable camera, the light moves with it.

Robust shrouds are attached to the machine mainframe to protect the video systems from rockfalls, etc. Considerable clearance was provided between the shrouds and the video systems so that shroud damage or deformation would not be translated to the video systems. Figure 6 shows the pan-tilt video system assembly with its protective shroud in the background.

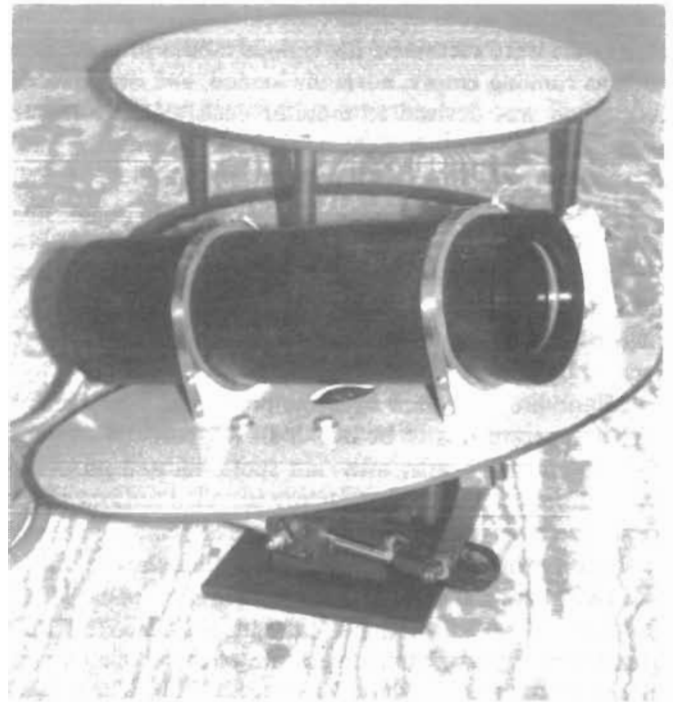

Figure 6.—Pan-tilt video system. (Photo by William H. Lewis, Pittsburgh Research Center.)

### Mining Machine and Haulage System Operational Conditions

Mining machine and haulage system parameters critical to maintaining safe and reliable operation are monitored by a suite of sensors and reported to the operator's display console. The sensors measured the following items: mining machine and haulage system motor currents, mining machine motor temperatures, oil reservoir level, oil temperature, pilot filter restriction, and face area methane level.

The Jeffrey model 102HP TSCM has one 95-hp hydraulic pump motor and two 125-hp auger drive motors. At a line voltage of 575 V ac, these motors have full-load currents approximately equal to their horsepower ratings (95 and 125 A). The rated current indicates that the motors can run continuously at the indicated current level and generate a tolerable amount of heat. The motor currents are measured with current transducers placed around their respective power leads. The pump and two auger motor current sensor outputs are conditioned and displayed on one 0 to 200-A and two 0 to 300-A readouts, respectively. The auger motor display range was a compromise to accommodate the major swings in current levels that can occur during mining operations.

To ascertain the operational status of the MUCH system, the conveyor motor currents are monitored. During surface testing of the MUCH system, conveyor motor current levels were measured for various modes of operation such as running empty, normally loaded, and overloaded. A method was devised to monitor each unit's conveyor current to detect either a chain breakage or conveyor jam. A 0 to 50-A motor current transducer was installed in each of the MUCH conveyor cars. An electronic detection circuit was constructed to activate an array of indicator lights. Figure 7 shows the current ranges associated with the expected conveyor conditions and the lights being off, being on, or flashing. The MUCH system motor displays were located between the workstation video monitors.

Motor life is limited by heat; prolonged operation at high temperature is to be avoided. All parts of a motor do not heat uniformly, with "hot spots" located on either the stator or rotor. Unless factory-installed sensors are at these locations, other temperature measurement methods are a compromise. To complicate matters, the motors on the TSCM are water cooled, causing the exterior case temperature to be affected not only by the electrical load (losses) but also by the temperature of the cooling liquid. Based on concessions between ease of installation and accuracy of measurement, a washer-type thermocouple

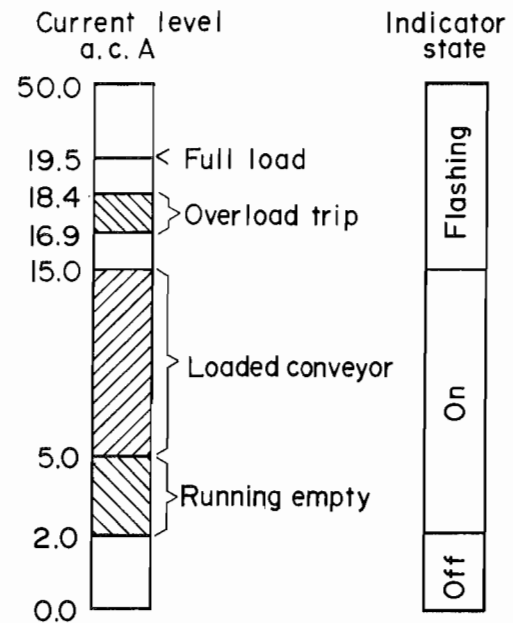

Figure 7.—Currents for conveyor haulage conditions.

mounted under a motor case bolt was selected. Since this device is installed outside the motor, the indicated temperature is influenced by factors that include cooling liquid temperature, ambient temperature, and motor load.

A continuous readout of the oil volume was initially desired. However, two problems became immediately apparent: (1) with a single-point measurement, the indicated level changes with pitching and rolling motions of the mining machine, and (2) the shape of the oil reservoir was so irregular that oil level and volume were related by a non-linear function. Figure 8 shows the shape of the reservoir (integrated into the mining machine chassis).

Because of these complications, a readout of oil level in inches was considered sufficient. Figure 9 shows a computer-generated plot, which was used to determine the oil volume from the indicated level. A radio frequency (RF) capacitance probe-type sensor was utilized because it produced a continuous reading, had no moving parts, and was intrinsically safe.

The measurement of oil temperature did not present any major problems. An immersion thermocouple probe of J-type materials was selected. This probe was threaded into a port formerly used for the reservoir level check plug.

Monitoring the pilot hydraulic filter condition was important because a blockage in the pilot pressure circuit would result in faulty operation of all remotely actuated

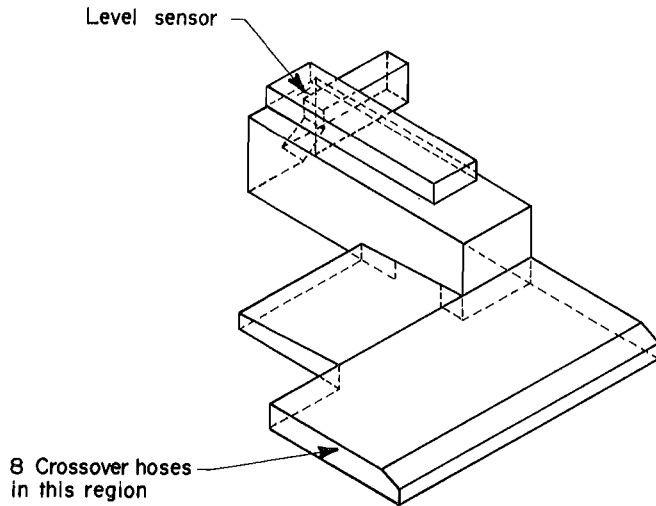

Figure 8.—Shape of thin-seam continuous miner oil reservoir.

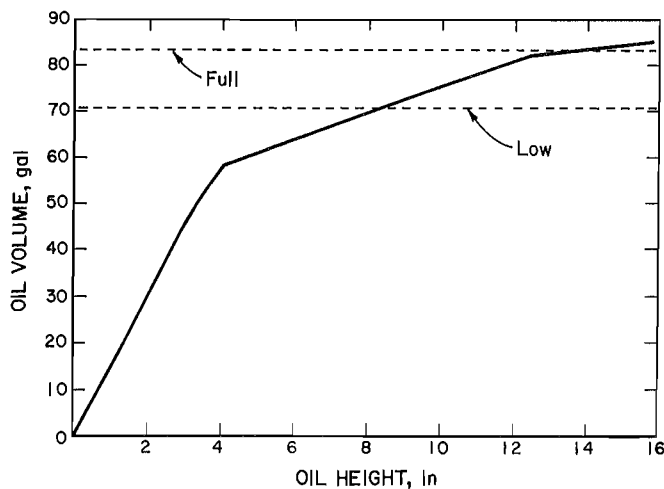

Figure 9.—Plot of oil level versus oil volume.

hydraulic functions. The original pilot filter was equipped with a visual indicator that activated if the back pressure across the filter exceeded 75 psig. Thus, a strain-gage-type differential pressure transducer having a range of 100 psig was selected.

The factory digital methanometer installed on the TSCM was unsuitable for producing an analog signal consistent with the other sensors. Therefore, it was replaced with an older style methanometer that had been modified by the manufacturer to make an analog signal available.

### *Operator's Perception of Mining Machine and Worksite Conditions*

Mining machine parameters, which help the operator perceive the operational status during the mining process, are measured by a group of sensors and transmitted to the operator's display console. The sensor set measures the following machine and site elements: auger boom height, conveyor height, sump distance, machine tilt, and face sounds.

Most of the measurement methods investigated sensed the auger boom angle rather than the direct auger height. However, for the small angle of movement, both the angle and height were considered linear functions. A rotary variable differential transformer (RVDT) was selected since it had no high-wear parts, was compatible with a standard linear voltage differential transformer (LVDT) conditioning module, and could be packaged in an environmental resistant enclosure. The RVDT was not considered to be intrinsically safe, so an explosion-proof (belt-speed switch) housing was used to enclose the sensor.

The same considerations for the auger height measurement applied to the conveyor height measurement. Instead of using another costly RVDT, it was decided to try a new type of inclinometer. This transducer used the principle of an electrolytic fluid contained in a chamber having varying capacitance to several electrodes depending on the orientation to the field of gravity. When mounted on the side of the conveyor boom, the inclinometer became tilted as the boom raised.

The TSCM does not tram into the coal face during the sump operation. Instead, a pair of hydraulic cylinders drive the auger head into the coal from a carriage mechanism built into the mining machine chassis. A readout of sump distance was required. For this measurement, a magnetostrictive transducer was utilized since its noncontacting method was expected to provide greater long-term reliability. A protective arrangement installed in parallel with an existing cylinder was constructed.

With the TSCM operating out-of-view, it would be difficult to determine whether the mining machine was assuming unusual pitch or roll attitudes referencing only the video monitors. On the other hand, it was desirable to let the mining machine conform to the pitch and roll of the seam. Thus, the mining machine tilt readouts enabled the operator to determine and hold fixed tilt angles. The sensor type used was identical to that used for conveyor height measurement. The pitch and roll inclinometers were installed in the remote computer enclosure.

An audio system was included to enhance the operator's perception of the mining machine-site interface during operation of the TSCM. Initially, a pair of dynamic microphones was chosen. The microphones were soon discarded when it was discovered that most ambient sounds were masked by sounds produced by the hydraulic pump motor and the conveyor. Better sound quality was produced by employing a pair of accelerometers on an auger head-bearing cap; one had a vertical orientation and the other was mounted longitudinally. With the accelerometers, airborne sounds were not detected. However, during coal-cutting operations, the machine vibrations were

well coupled to the accelerometers. The amplified signals were channeled to the operator's headphones.

#### *Display Console*

The 16 sensor signals derived from the TSCM were displayed on LED vertical bar graph meters (fig. 4). The meters had several options, including a digital readout, alarm levels, and set points. The alarm is indicated by a flashing light whenever a preselected input voltage is exceeded. For those parameters that go into an alarm state for decreasing input voltage (oil level, pitch, roll), the lower set point was used instead of the alarm light.

## SURFACE EVALUATION AND REFINEMENT

Surface evaluation and refinement of the teleoperated THMS components were conducted from December 1987 through October 1988 (6). This was done at the Pittsburgh Research Center's Mine Equipment Test Facility (METF) located in Bruceton, PA.

The initial cutting trial of the modified TSCM used a block of simulated coal, coalcrete (fig. 10). The operator's

controls and displays were mounted in temporary fixtures located near the test site. Although successful, this testing revealed several areas in which the teleoperational system required improvements. The most significant of these problems was appreciable delays caused by the computer system in updating displays of data obtained from the TSCM-based sensors. An additional delay occurred from

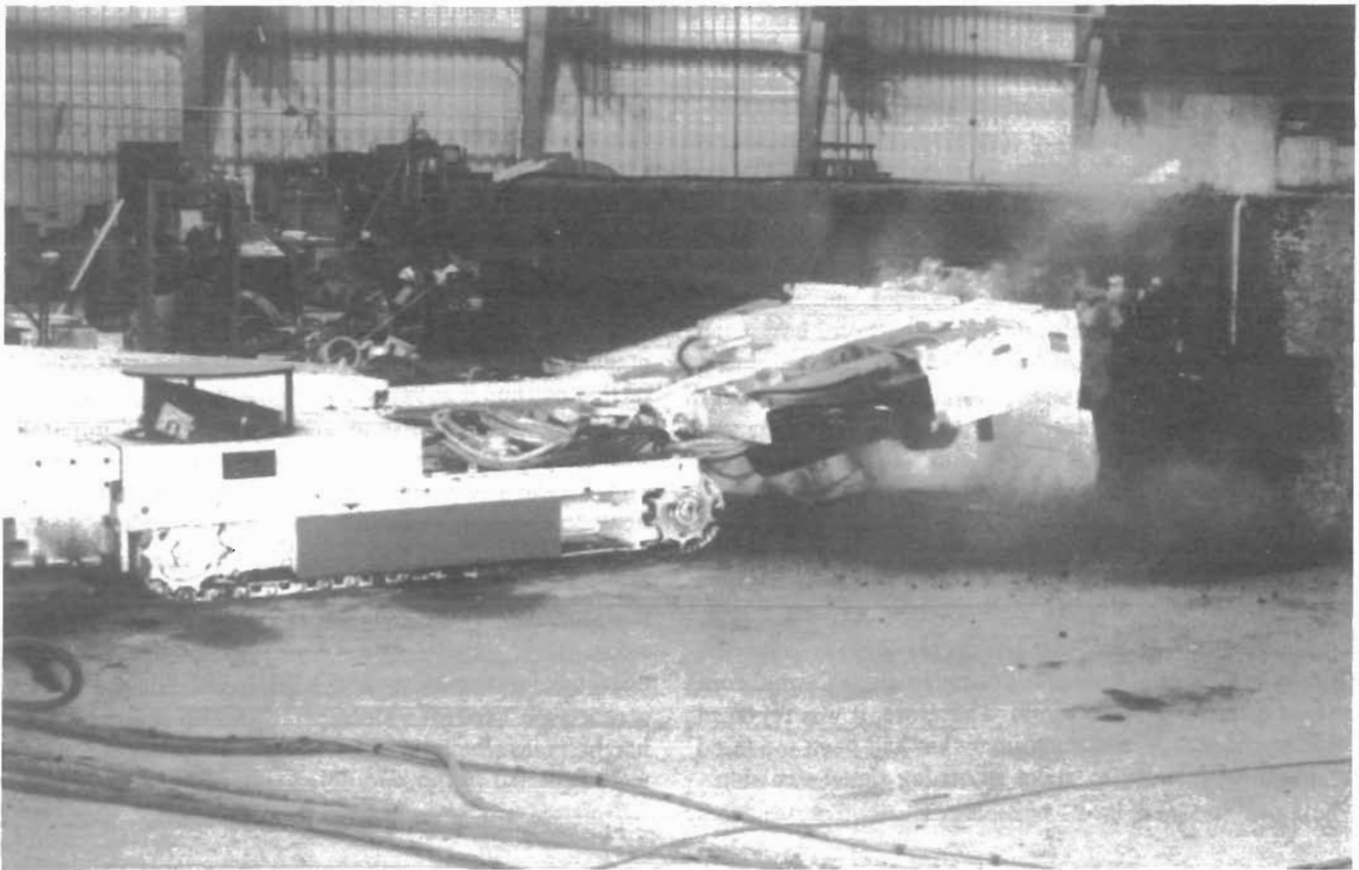

Figure 10.—Surface-cutting trials.



the time a function was activated to the time the mining machine responded. After the initial testing, the tele-operating system was repackaged to its operational configuration. This included transferring all control and display devices from the breadboarded fixtures to the final modules of the ergonomically designed operator workstation and structure.

Results from the surface-testing activities prompted the following events:

1. Upgrade of the master and remote computers to utilize Intel "BITBUS" communications boards. This change was expected to increase greatly the speed of data exchange between the computers. However, after the change was made, the speed increase was noticeable, but not initially satisfactory. Considerable testing and re-programming was required to bring the effective communication speed between the master and remote computers up to a satisfactory level (see tables 2 and 3).

**Table 2.—Average computer delay times, milliseconds**

Configuration	Command		Signal	
	Turn-on	Turn-off	Increase	Decrease
Multibus system . . .	302.3	324.0	1,575.5	1,455.0
Original BITBUS system.	571.0	737.1	528.7	504.5
BITBUS with first revision.	263.2	501.1	493.8	497.8
BITBUS with second revision.	344.6	288.5	783.3	1,054.5
BITBUS with third revision.	250.5	218.4	565.6	460.1

**Table 3.—Maximum computer delay times, milliseconds**

Configuration	Command		Signal	
	Turn-on	Turn-off	Increase	Decrease
Multibus system . . .	549.5	554.5	2,299.0	2,351.0
Original BITBUS system.	1,081.5	1,096.5	738.5	852.0
BITBUS with first revision.	565.5	683.5	930.0	757.5
BITBUS with second revision.	650.5	692.0	1,530.0	1,299.0
BITBUS with third revision.	428.0	742.5	818.5	789.0

To quantify the delay, a test was devised so the benefit of subsequent improvements could be determined. A dual channel oscilloscope was used to record simultaneously the switched input voltage at the master computer and the step-change output voltage at the remote computer. The movable camera "focus-in" channel was used for commands from the master to remote, and the "face-distance" channel was used for signals from the remote to master.

The delay in response was measured with the oscilloscope's vertical cursor. Since the delay varied randomly from one trial to the next, 20 trials were made for each software revision to find the average and maximum delays. Table 2 shows the average delays for each version. Table 3 shows the maximum delay times. The last version listed was left installed.

2. "Armor-plating" the machine-mounted electronics to be able to survive the harsh mining environment. This included (1) sealing the electronics to prevent moisture intrusion, (2) pressurizing the two explosion-proof enclosures with conditioned air, and (3) testing and modifying the electronic hardware and mountings to increase their capability to withstand vibration and shock.

Several maneuvers were conducted with the Jeffrey model 102HP TSCM to characterize the vibrations imposed on the machine-based electronics. It was hoped that resilient mounts could be selected that would result in a mounted natural frequency different from any vibrations experienced by the mining machine. The instrumentation shown in figure 11 was installed on the mining machine, and vibration data were recorded while tramming, sumping, and shearing into the simulated coal block. Three accelerometers were installed on the computer enclosure in each of the three orthogonal directions, and one accelerometer was installed on the sensor box in the vertical direction.

Based on a statistical analysis of the resulting data (with no regard to frequency), root mean square (RMS) vibration levels shown in table 4 were observed. Computer box transverse vibration while tramming was apparently the most severe; however, high-frequency vibration (of small displacement) from the hydraulic pump was the most likely to be coupled into the computer box.

**Table 4.—RMS vibration on Jeffrey mining machine by activity, gravity root mean square**

Location	Pump on	Tram	Sump	Shear
Computer box:				
Vertical . . . . .	0.221	0.263	0.392	0.457
Transverse . . . . .	.374	.659	.540	.570
Longitudinal . . . . .	.140	.231	.259	.287
Sensor box: Vertical . .	.176	.448	.579	.690

Figure 12 shows a representative spectral plot of computer box vertical acceleration during a coal-shearing operation. Most vibration mounts are designed to result in a mounted natural frequency of 10 to 20 Hz. As can be seen by the plot, this spectral region is rich in machine-borne vibration. Eventually, 15-Hz mounts were selected and snubbers were installed under the computer assembly to damp severe oscillations when they occurred.

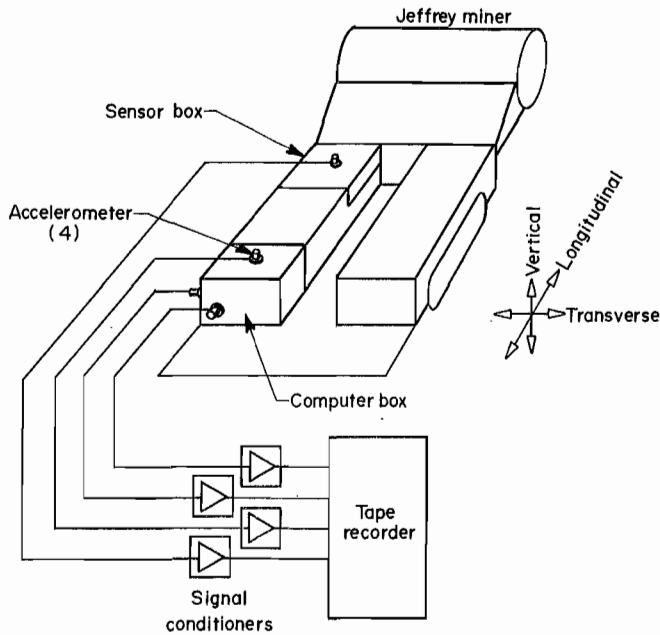

Figure 11.—Instrumentation for recording vibration data.

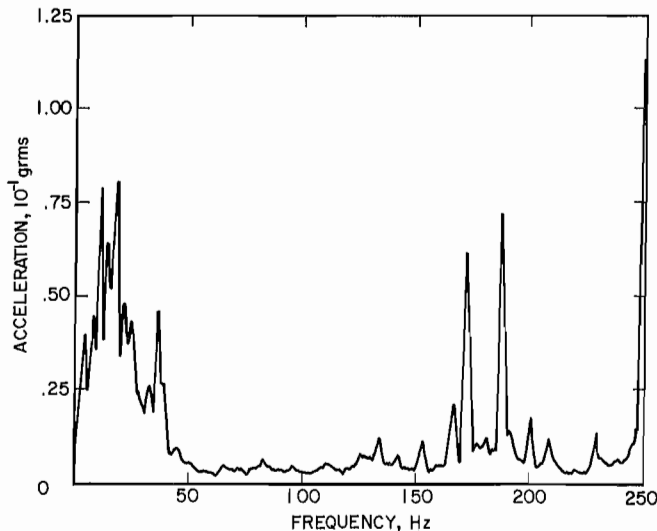

Figure 12.—Spectral plot of vertical acceleration data during coal cutting.

3. Incorporating a third video subsystem mounted on the TSCM. This subsystem employed a compact B&W camera and headlamp enclosed in a protective housing. It was mounted on the TSCM to allow viewing either the left track and surrounding floor area (behind the gathering plow) or the coal transfer point from the TSCM tail boom to the receiving hopper of the lead MUCH vehicle. A special-effects generator was used to view simultaneously,

on the same monitor, the output from both the B&W camera and a color camera.

4. Designing, fabricating, and refining an innovative sound subsystem that provides the operator with audio signals that originate from the output of accelerometers mounted on the cutting boom of the TSCM. For this, a patent application Serial No. 645,430, entitled "Cutting Sound Enhancement System for Mining Machines," was filed.

5. Designing, fabricating, and partially testing an innovative ventilation subsystem. Ventilation was required at the working face to maintain dust at a level low enough to maintain adequate visibility for the remote video subsystems. The ventilation subsystem is unique in that it (1) is semiflexible, (2) runs along the entire length of the THMS, (3) is carried by the MUCH system and TSCM, and (4) allows for 10 ft of relative movement between the tail boom of the TSCM and the lead MUCH vehicle. For this, a patent application Serial No. 533,647, entitled "Suspension Arrangement for Flexible, Retractable Air Conduit," was filed.

6. Designing, testing, and refining a laser alignment subsystem. The alignment subsystem provided a means to allow the operator to keep the THMS advancing in a desired, straight-line trajectory. The primary purpose was to minimize roof falls by maintaining adequate barrier pillars between extraction entries.

After considerable investigation of several complex and expensive alignment and guidance methods and equipment, a line-of-sight, laser-based alignment subsystem was selected with the goals of it being effective, economical, and easy to use. This subsystem added only two components to the THMS: (1) a bench-based laser with its beam fixed, but adjustable, within a desired vertical plane, and (2) a self-cleaning target mounted on the front end of the TSCM. The target is a Teflon fluorocarbon polymer strip fixed to a heavy metal substructure. The target is parallel to the longitudinal axis of the TSCM and moves with the angular motion of the cutting auger head during shearing operations. The target and laser spot are viewed by the operator through one of the two color video subsystems. The operator maintains the desired course by maintaining the laser spot on the fluorocarbon polymer strip as the auger head and target move up and down during shearing operations. If the laser spot does not fall on the target or does not follow the fluorocarbon polymer strip, then the TSCM is not oriented along the path of the laser beam and the operator must correct the trajectory of the THMS. The visibility of the fluorocarbon polymer target is maintained by passing pressurized air over its surface.

The satisfactory operation of the teleoperation subsystem was confirmed through performance testing at the METF using 12 different operators. Among the operators were two of the cooperators's employees (this also served

as a training session). The consensus was that the TSCM could be controlled through the Bureau's teleoperation subsystem.

## SURFACE EVALUATION RESULTS

The overall surface-testing results were positive, demonstrating that the remote operators were provided adequate sensory information on which to base decisions and control the equipment. Specific results included (1) establishing control of machine and video subsystem functions over a 450-ft cable, (2) transmitting, processing, and presenting sensory information from 3 video subsystems, 16 analog sensors, and 2 audio sources, (3) upgrading the computers to increase the data transfer speed to a

satisfactory level, (4) the expected fact that operators found the video information a very useful input, (5) the somewhat unexpected fact that operators considered the accelerometer-based sound information about as valuable as the video information, (6) that the motor current displays were useful for determining if the cutting auger was in air, coal, or other material, and (7) that the ergonomically designed workstation formed a very satisfactory interface between the operator and the equipment.

## PREDEPLOYMENT ACTIVITIES

The modified TSCM, the teleoperator station, and the MUCH system were shipped to the cooperators's facilities in Morgantown, WV, during October 1988. Modifications continued at the cooperators's facilities to ready the THMS for initial production evaluation. Tasks that were conducted included

1. Installation of the remote operator station in the mainframe structure.
2. Modifications to the TSCM to include the addition of retrieval sheaves and lift jacks to allow for correcting the positional list of the machine.
3. Packaging the teleoperational control, machine power, and other cables in a protective cable bundle and fabricating a cable-handling apparatus.
4. Refining Bureau-generated cable-handling designs to allow 10-ft movement between the lead haulage vehicle and the TSCM.

5. Installing components of the Bureau-designed ventilation subsystem.

6. Modifying the equipment hydraulic systems, electrical cables, video subsystems, and protective covers to increase reliability and ease maintenance.

In June 1989, the THMS was assembled. This was the first time that the main components of the THMS—the TSCM, MUCH system, and mainframe structure—were combined as a unit. Bureau personnel wired the system to operate from the teleoperator's workstation.

Before the actual field evaluation began, the cooperators and Bureau personnel met to clarify their respective responsibilities. It was agreed that (1) the cooperators would be responsible for securing and preparing the site, and operating the equipment, and (2) the Bureau would provide support to maintain the teleoperational and other electrical subsystems.

## FIELD DEPLOYMENT OF TELEOPERATED HIGHWALL MINING SYSTEM

During August and September 1989, the THMS underwent a brief, successful shakedown trial at a highwall site located near Morgantown, WV (7). Figure 13 shows the THMS at the Sennett Triplett's Strip-Auger Sell Site located in Marion County, near Sugar Grove, WV. The site was selected primarily on the basis of availability and was permitted to allow auger mining.

A short bench with exposed highwall, approximately 80 ft in width, was left for the THMS by the strip mine

operator. Strata exposed at the highwall consisted of the 55-in Lower Waynesburg seam, a 12-in shale binder, and the 39-in Upper Waynesburg seam. This was overlain by approximately 12 ft of competent shale and 20 ft of sandstone. Overburden at the immediate highwall was approximately 35 ft; this increased rapidly to a maximum of about 100 ft approximately 125 ft (horizontal) from the highwall face. The immediate bench floor consisted of several inches of coal underlain by clay. The bench floor



Figure 13.—Teleoperated highwall mining system at production site.

remained wet because of water flowing from a corner of the highwall. Neither core drilling nor other reliable geologic information was available for the site.

The TSCM is capable of cutting to a maximum height of 48 in above the floor. Thus, the strategy was to try to mine from the bottom of the Lower Waynesburg seam up to the 48-in cutting limit, leaving about 6 in of top coal. It was hoped that the top coal would help to hold the rock binder between the Lower and Upper Waynesburg seams. The coal seams pitched down approximately 6% beginning at the highwall face.

When mining near the highwall face, rather massive roof falls occurred approximately every 10 ft of advance. The falls consisted of the roof coal and rock binder and often caused both color video subsystems to become effectively unusable because of the accumulation of strata on the top of the TSCM. The strata tended to block both the lines-of-sight from the cameras to the face and the illumination from four out of a total of five TSCM-mounted headlamps. This required that the THMS be retracted from the entry and the debris be cleared. Neither the video subsystems nor other sensory equipment were

damaged by the falling strata, and the TSCM remained capable of advancing in the entry. The operator was capable of judging the response of the machinery to the actuation of controls through the remaining sensory outputs, especially the accelerometer-based sound subsystem.

Actual mining occurred for two entries that were extracted to an average depth of 120 ft. Approximately 462 st of coal were extracted and conveyed. The coal was produced at an average rate of 1.6 st/min, and the entries were advanced at an average rate of 0.8 ft/min. Four workers plus a supervisor were required to operate the THMS. The workers consisted of the main operator (teleoperator), a person who primarily connected ventilation ducts, a person who primarily advanced and retracted the cable ribbon, and a person who collected coal discharged from the end of the MUCH system using a front-end loader.

Additional mining was not attempted at the site because of numerous roof falls, extremely wet conditions, and the line-of-sight laser alignment system operating outside of its design range owing to unusual pitching of the coal seam.

## FIELD EVALUATION RESULTS

Although the full production potential of the THMS was limited owing to conditions mentioned previously, this new mining system performed at or above expectations. Accomplishments included the following:

1. The THMS successfully mined coal on the initial attempt, even though the teleoperator had no prior experience in controlling a mining system.
2. Virtually all the new technologies met or exceeded expectations. This included the prototype MUCH haulage system, the computers and software, the three TSCM-mounted video subsystems, other machine-mounted sensors, and the ventilation subsystem. Especially noteworthy were the performances of the ergonomically designed workstation and the accelerometer-based sound subsystem.

3. The sensory equipment survived extremely harsh conditions including many roof falls. At one point, it was observed that the water level in an entry was halfway up (about 18 in above the floor) the explosion-proof enclosure containing the remote computer.

Since the conclusion of the initial field trial, the cooperator has sought a new highwall site with better (normal) conditions for continued production evaluation of the THMS. If new production sites continue to have coal seams where the pitch changes appreciably over the 275-ft penetration depth, a new alignment subsystem should be used with the THMS. The existing technique that appears most promising, but expensive, is a ring-laser gyroscope system.

## RECOMMENDATIONS FOR IMPROVEMENT

Based on the experience gained with the THMS during the surface and field testing, several conclusions were reached concerning the present system. In general, the following improvements could be made.

### HIGH-SPEED DATA TRANSMISSION

The testing revealed that a perceptible delay exists between the actuation of a switch control and the response of the equipment. A corresponding delay is apparent between a change in sensory input to the updating of the bar graph meters. The computer-controlled data link was determined to cause a significant portion of the delay. A future system should employ a revised computer architecture and, if necessary, a higher speed transmission medium to decrease the delay time.

### MAINTAINABILITY

As more equipment was added to the prototype THMS, it evolved into a complex mining system and maintenance considerations were difficult to implement. As a result, many of the test points are difficult to reach and cables hard to trace.

A confining space in the bottom part of the computer cabinet was reserved for electronic equipment. Mounting of this equipment in an upright standard 19-in rack would have been preferable. An entire panel could be reserved for the interconnections presently made in the "access box" and computer compartment.

Extensive use of indicators would be helpful in troubleshooting system malfunctions. Consideration should be given to the following indicators: power supply voltages, data link status, mining machine alternating current (ac) power, MUCH ac power, mining machine computer power, emergency-stop enabled, pump, and cutter contactors energized.

### VIDEO SYSTEM AVAILABILITY

Coal production from the THMS was hampered because, on several occasions, the system had to be withdrawn from the entry to clear fallen strata that blocked views from the color video cameras and face illumination provided by the headlamps. The falls varied considerably in volume and consisted of roof coal and the overlaying rock. The frequency of the falls was contributed to by the poor roof conditions at the test site.

These field test results indicate that video subsystem modifications may be desirable to reduce the need to pull the THMS entirely from the active entry to clear roof falls. Although no panacea solution appears possible, several modifications are worth consideration:

1. Incorporating a mechanical "wiper arm" to sweep rock from the area in front of the movable video subsystem. A mechanism that incorporates a hydraulic rotary actuator and structural angle (for the wiper) appears promising. A problem is that little free space exists on a TSCM, either above or below the steel protective covers,

for the mechanism and its electrical and hydraulic components.

2. Including rotating plates (miniature versions of continuous miner gathering heads) in front of the two headlamps on the auger boom. The idea is that, instead of

strata debris accumulating in front of the headlamps to block the illumination, centrifugal force would cast it off the plates as it landed. A problem is to fit, within the available space, power components and plates so sufficient centrifugal forces are developed.

## CONCLUSIONS

The teleoperation of mining equipment appears as a promising, flexible, present-day means to achieve safe, efficient mining operations. The Bureau was able to demonstrate that teleoperation is a feasible and attractive technology. This was achieved through the successful surface and field operation of the THMS, a complex, totally

new mining system composed of many subsystems. If the development of teleoperational mining equipment continues successfully and is accepted by the industry, this technology should mark a significant milestone in achieving safer mining operations.

## REFERENCES

1. Jaspal, J. S., L. A. Erhard, and W. D. Mayercheck. Surface Testing and Evaluation of the Multiple-Unit Continuous Haulage System. BuMines IC 9228, 1989, 60 pp.
2. Evans, R. J., and W. D. Mayercheck. Coal Extraction, Transport, and Logistics Technology for Underground Mining. BuMines IC 9181, 1988, 81 pp.
3. Mayton, A. G., and J. C. Volkwein. Ventilation for New Highwall Mining System. Paper in U.S. Mine Ventilation Symposium. AIME, 1989, pp. 209-216.
4. Kwitowski, A. J., W. H. Lewis, and W. D. Mayercheck. Ergonomically-Designed Operator Workstation for a Computer-Aided, Remotely Controlled Mining System. Paper in ICE-O-SHE, China, 1988, v. 1. Computer Soc. Australia, 1988, pp. 362-373.
5. Schiffbauer, W. H. An Intelligent Remotely Operated Controller for Mining Machines. Paper in the Use of Computers in the Coal Industry (Proc. 1986 Conf. WV Univ., Morgantown, WV). WV Univ., 1986, pp. 27-30.
6. Kwitowski, A. J., W. H. Lewis, and W. D. Mayercheck. Computer-Based, Teleoperation of a New Highwall Mining System. Paper in Robotics and Automation, v. 3 (Proc. 1989 IEEE Intl. Conf., Scottsdale, AZ). IEEE Computer Soc. Press, 1989, pp. 1478-1483.
7. Kwitowski, A. J., W. D. Mayercheck, and A. L. Brautigam. Teleoperation for Continuous Miners and Haulage Equipment. Paper in International Mining Electrotechnology Conference (Proc. 1990 Conf. WV Univ., Morgantown, WV). WV Univ., 1990, pp. 94-101.

## APPENDIX.—SENSORY INFORMATION FROM MINING MACHINE

<i>Sensor information</i>	<i>Suggested sensor type</i>
Auger head height .....	Rotational resolver.
Height of tail boom .....	Do.
Oil temperature .....	Thermocouple.
Oil level .....	Optical level sensor and 2 inclinometers.
Hydraulic system filter restriction ..	Pressure sensors before and after filter.
Motor temperatures (3) .....	Thermocouples.
Motor currents (3) .....	Toroid-shaped transducers.
Rib thickness .....	Unresolved; possibly probe drill.
Methane level .....	Commercial mining unit.
Face sounds .....	Stereo microphones.
Depth of sump .....	Linear resolver.
Fire (ambient temperature) .....	Thermocouple.