

RI 9364

RI 9364

REPORT OF INVESTIGATIONS/1991

PLEASE DO NOT REMOVE FROM LIBRARY

Utilizing Mechanical Linear Transducers for the Determination of a Mining Machine's Position and Heading

By Christopher C. Jobes

UNITED STATES DEPARTMENT OF THE INTERIOR



BUREAU OF MINES

U.S. Bureau of Mines
S. Research Center
E. Montgomery Ave.
Spokane, WA 99207
LIBRARY

Mission: As the Nation's principal conservation agency, the Department of the Interior has responsibility for most of our nationally-owned public lands and natural and cultural resources. This includes fostering wise use of our land and water resources, protecting our fish and wildlife, preserving the environmental and cultural values of our national parks and historical places, and providing for the enjoyment of life through outdoor recreation. The Department assesses our energy and mineral resources and works to assure that their development is in the best interests of all our people. The Department also promotes the goals of the Take Pride in America campaign by encouraging stewardship and citizen responsibility for the public lands and promoting citizen participation in their care. The Department also has a major responsibility for American Indian reservation communities and for people who live in Island Territories under U.S. Administration.

Report of Investigations 9364

**Utilizing Mechanical Linear Transducers
for the Determination of a Mining
Machine's Position and Heading**

By Christopher C. Jobs

**UNITED STATES DEPARTMENT OF THE INTERIOR
Manuel Lujan, Jr., Secretary**

**BUREAU OF MINES
T S Ary, Director**

Library of Congress Cataloging in Publication Data:

Jobs, Christopher C.

Utilizing mechanical linear transducers for the determination of a mining machine's position and heading / by Christopher C. Jobs.

p. cm. — (Report of investigations / Bureau of Mines; 9364)

Includes bibliographical references (p. 19).

Supt. of Docs. no.: I 28.22:9364.

1. Mining machinery—Automatic control—Data processing. 2. Transducers.
I. Title. II. Series: Report of investigations (United States. Bureau of Mines); 9364.

TN23.U43 [TN345] 622 s—dc20 [622'.028] 90-25450 CIP

CONTENTS

	<i>Page</i>
Abstract	1
Introduction	2
Background	2
Problem definition	2
Topological requirements	2
Functional requirements	2
Constraints	3
Mechanical position and heading system	3
Theory	3
Sensors	3
Navigation reference frames	4
Closed-form solution	4
Implementation	5
Hardware	5
Software	6
System	12
Error analysis	13
Numerical analysis	14
Algebraic analysis	14
Testing the mechanical position and heading system	15
Surface testing	15
Setup	15
Procedure	16
Results of Joy 14CM and Joy 16CM mining machine tests	16
Underground testing	16
Setup	16
Procedure	16
Conclusions and recommendations	18
References	19

ILLUSTRATIONS

1. British Coal trolley-pole device	2
2. Linear position transducer	3
3. Directly solvable redundant four-transducer configuration	4
4. Local and machine reference frames and position vectors	4
5. Configuration for position and heading algorithm	4
6. Location of sensors, cables, and computer enclosure on Joy 14CM mining machine	7
7. LPT mounts for MPHS	7
8. Intrinsically safe LPT circuit for MPHS	8
9. Block diagram of MPHS computer enclosure	9
10. MPHS computer enclosure chassis	10
11. Data flow diagram for Bitbus node tasks	11
12. Data flow diagram for command handler task	11
13. Data flow diagram for position and heading calculator task	12
14. BOM/NET for field trial system with Joy 14CM mining machine	13
15. Results of advance numerical simulation	14
16. Results of crosscut numerical simulation	14
17. Joy 14CM mining machine configured for MPHS surface tests	15
18. Data for Joy 14CM mining machine surface advance test	17

ILLUSTRATIONS

Page

19. Data for Joy 14CM mining machine surface crosscut test.	17
20. Data for Joy 16CM mining machine surface advance test	17
21. Data for Joy 16CM mining machine surface crosscut test	17
22. Configuration for MPHS underground tests	18

UNIT OF MEASURE ABBREVIATIONS USED IN THIS REPORT

A	ampere	mA	milliampere
A·h	ampere hour	mm	millimeter
ft	foot	nA	nanoampere
h	hour	pct	percent
Hz	hertz	rad	radian
in	inch	s	second
m	meter	V	volt

OTHER ABBREVIATIONS USED IN THIS REPORT

A/D	Analog-to-digital	MPHS	Mechanical position and heading system
BOM/NET	Bureau of Mines Network	RMS	Root-mean-squared
CM	Continuous miner	RODNE	Remote operator and diagnostic node
FS	Full-scale	RSS	Root-sum-squared
I/O	input-output	UIC	User interface connector
IS	Intrinsically safe	X/P	Explosion-proof
LPT	Linear position transducer		

UTILIZING MECHANICAL LINEAR TRANSDUCERS FOR THE DETERMINATION OF A MINING MACHINE'S POSITION AND HEADING

By Christopher C. Jobes¹

ABSTRACT

Computer-aided control of a mining machine requires a guidance system to aid remote positioning of the machine by determining its position and heading. The mechanical position and heading system (MPHS) developed by the U.S. Bureau of Mines provides such navigation information during face maneuvers. This report describes the required theory, which yielded a reliable algorithm for calculating machine position and heading, and implementation of this theory in hardware and software design, which made surface testing of the MPHS possible. Analysis of the errors and test results showed that the MPHS provides reliable results and can, therefore, provide useful guidance information for face navigation.

¹Mechanical engineer, Pittsburgh Research Center, U.S. Bureau of Mines, Pittsburgh, PA.

INTRODUCTION

Computer-aided operation of mining equipment at the face should increase worker safety, health, and efficiency, by allowing the operator to be placed in a safe, remote location. An important requirement of computer-aided control of face operations under current continuous mining practices is a navigation or guidance system (1).² As part of its health and safety program, the U.S. Bureau of Mines has developed the mechanical position and heading system (MPHS) to provide guidance information for mining machine navigation in the face area.

BACKGROUND

Mobile mining equipment must be able to navigate when operating in the face area of an entry or developing crosscut. Continuous mining machines and roof bolters typify the types of equipment that perform such face navigation (2).

Designing a navigation system for a self-guided mining machine is difficult. Current navigation research for mobile machines focuses on electromagnetic, stress wave, and mechanical principles. Most of this work is in the electromagnetic (optical, laser, radar, magnetic compass, etc.) and stress wave (ultrasonic) domains, with very little attention paid to mechanical guidance methods. A mechanical method may, however, yield a cheaper and more reliable system.

Mechanical guidance systems usually involve dead reckoning (chiefly machine motion relative to ground) or mechanical attachment. Errors are cumulative in dead reckoning; therefore, a system relying on dead reckoning alone is unreliable—particularly in a mining environment. Most navigation system designers, however, either are unwilling to restrict the motion of their machines or lack the confining environment to make mechanical attachment viable. The face area of an entry confines a mining machine, making it an ideal candidate for mechanical attachment.

One attachment method for the guidance of a mining machine, using a trolley-pole-type articulated boom (fig. 1), provides guidance information for a roadheader (3). The articulated boom instruments six degrees of freedom (one linear and five revolute joints). This method uses the standard robot kinematic technique to determine the position and orientation of the roadheader in a local reference frame. This system appears to perform adequately, but was not considered for use in face navigation since there is not enough overhead room available to the continuous mining machine in the typical entry.

PROBLEM DEFINITION

The MPHS is a mechanically attached system. An adequate mechanical design requires a definition of the system's requirements and constraints.

Topological Requirements

Topological requirements are the minimum set of defined parameters needed before users can systematically enumerate the kinematic chain of a mechanism. Two of the parameters used are the space (planar or spatial) in which the mechanism moves and the mechanism's degree of freedom. The third parameter is the number of either links or independent loops in the mechanism needed to yield a finite solution set. Any additional specifications made at this point in the design procedure further reduce the number of solutions.

A coal seam cannot be considered a smooth plane for even a short distance. Therefore, a mining machine has a spatial rather than planar nature of motion. An object with a spatial motion has six degrees of freedom (x , y , z , roll, pitch, and yaw). The MPHS, since it measures the position and orientation of a spatial object, requires six degrees of freedom.

Functional Requirements

Functional requirements are the tasks required of the mechanism being designed. Of a mining machine's six degrees of freedom, three (z , roll, and pitch) are insignificant. The position and heading (x , y , and yaw) are the important unknowns measured. Therefore, the only task

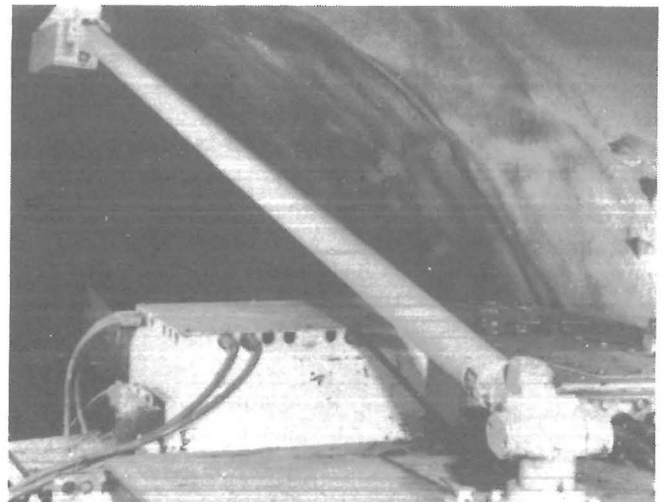

Figure 1.—British Coal trolley-pole device.

²Italic numbers in parentheses refer to items in the list of references at the end of this report.

of the MPHS mechanism is to track the position and heading of a mining machine.

Constraints

Two types of constraints affect the design of the MPHS mechanism: dimensional and inertial. These constraints determine the feasibility of a mechanism found to satisfy the topological and functional requirements.

Some of the dimensional constraints on the mechanism connecting the mining machine to the local reference frame are—

1. Minimizing potential contact of the mechanism with the ribs or uncut coal blocks in the entry while it performs its required task.
2. Minimizing interference with the mining machine's task so taking measurements is not a hindrance.
3. Allowing a 12.192-m (40-ft) forward advance or a 6.096-m (20-ft), 1,571-rad (90°) crosscut to increase productivity during the automated cutting cycle.

4. Avoiding interference with the mining machine conveyor boom and shuttle car (if not using continuous haulage).

5. Avoiding contact with the ventilation curtain (if present).

Some of the inertial constraints on the mechanism connecting the mining machine to the local reference frame are—

1. Minimizing the inertia of the mechanism to reduce the loading of the mining machine and the mechanism's resolving joints.
2. Minimizing the mass of the mechanism to reduce its interference with mining machine operation.
3. Maintaining accurate measurements during the movements of the mining machine, which requires a stiff mechanism.
4. Surviving encounters with uncut coal blocks, mining machine appendages, etc., which requires a compliant mechanism.

MECHANICAL POSITION AND HEADING SYSTEM

The MPHS development had two parts: learning the theory governing the MPHS and developing the enabling hardware and software. Reference 4 presents a more exhaustive treatment of the MPHS theory development than that provided here.

THEORY

The MPHS theory development was divided into three parts. The first step was to characterize the measurement configuration and the sensors used. The next was to select and define navigation reference frames. The last was to derive a closed-form solution determining the position and heading from sensor information.

Sensors

Choosing the sensors and their measurement configuration requires much thought. The constraints placed on the mechanism by the environment at the face eliminate a rigid articulated linkage. Thus, angle-measuring sensors are not appropriate. In order for distance-measuring sensors to perform the required task, they must be configurable as a six-degree-of-freedom mechanism. Thus, the logical sensor is a linear position transducer (LPT) or wire pull (fig. 2). The LPT can measure fairly long distances, has an infinite degree of freedom, and is compliant enough to survive most contacts with obstructions.

Although position and heading can be found by using a configuration of three LPT's, four LPT's provide redundancy for reliability. Any nondegenerate configuration of four LPT's allows calculation of the position and heading. The selected configuration, however, affects the computation method and effort required. Positioning the LPT's so each mounting location is different and the wire

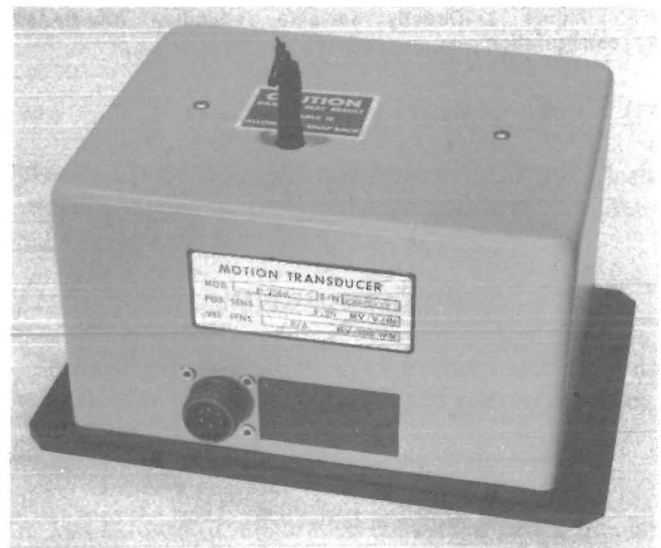

Figure 2.—Linear position transducer (approximately 22.9 by 15.2 by 11.4 cm).

attachment points are different results in a set of nonlinear transcendental equations requiring an iterative solution (4). Configuring the LPT's by pairing their locations and attachment points (fig. 3) yields directly solvable equations.

Navigation Reference Frames

Position and heading are crucial when navigating a mining machine. Deriving the position and heading of a mining machine requires knowledge of the transducer points on the mining machine, the attachment points off the machine, and their relationship to each other. Attaching a machine reference frame (fig. 4) to the mining machine defines the location of points on the mining machine. Fixing a local reference frame to a stationary point behind the mining machine defines the location of points in the entry. Using the standard coordinate transformation technique allows description of any point on the mining machine in the local reference frame. The location information for the LPT mounts and the wire attachment

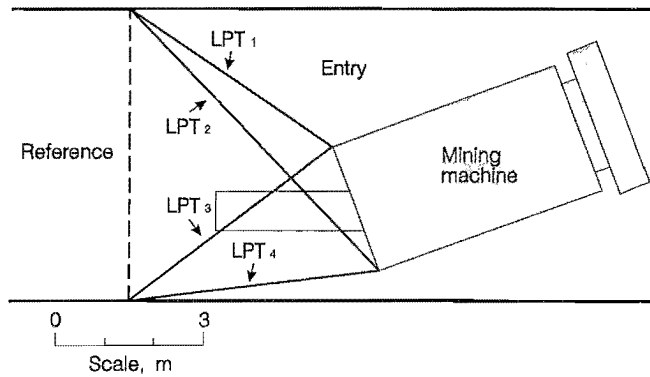

Figure 3.—Directly solvable redundant four-transducer configuration.

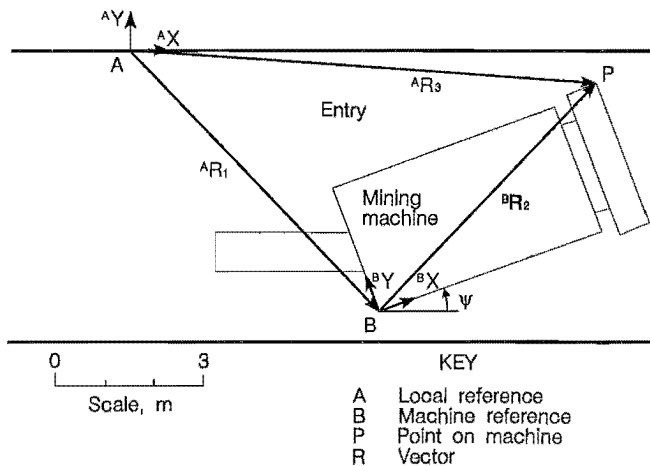

Figure 4.—Local and machine reference frames and position vectors.

points allows description of the mining machine's position and heading in the local reference frame.

Closed-Form Solution

A closed-form solution allows easier calculation of the position and heading than an iterative method allows. First, the solution process requires configuring the LPT's and defining all position vectors of interest (fig. 5). Applying coordinate transformation analysis of planar mechanisms to this configuration determines four pairs of

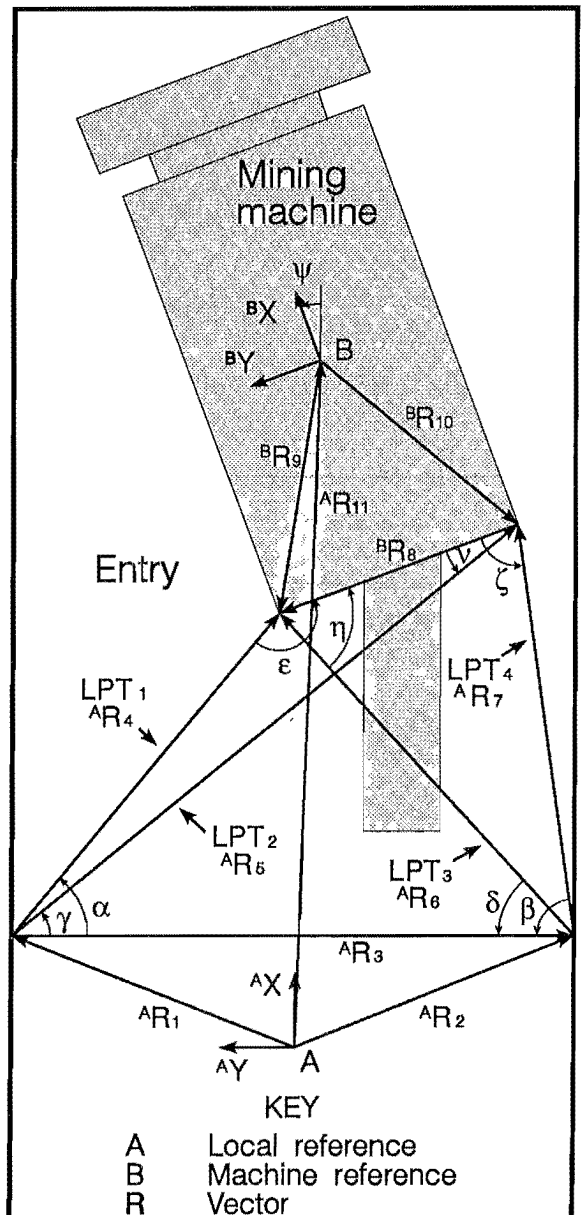

Figure 5.—Configuration for position and heading algorithm.

three-transducer solutions. Intermediate results yield a four-transducer solution.

In the pair of three-transducer solutions that include LPT₄ data, the direction of LPT₁'s cable and the mining machine's heading are

$$\theta_4 = \theta_3 + \cos^{-1} \left[\frac{r_3^2 + r_4^2 - r_6^2}{2r_3r_4} \right] \quad (1)$$

$$\text{and } \psi_4 = \pm \cos^{-1} \left[\frac{r_4^2 + r_8^2 - r_5^2}{2r_4r_8} \right] - \theta_8 + \theta_4, \quad (2)$$

respectively, and the mining machine's position is

$$x_{11} = r_1 \cos \theta_1 + r_4 \cos \theta_4 - r_9 \cos(\theta_9 + \psi_4) \quad (3)$$

$$\text{and } y_{11} = r_1 \sin \theta_1 + r_4 \sin \theta_4 - r_9 \sin(\theta_9 + \psi_4), \quad (4)$$

where the subscripts 1 to 11 indicate the vector to which the polar coordinate components (r and θ) and Cartesian coordinate components (x and y) refer.

In the pair of three-transducer solutions that exclude LPT₃ data, the direction of LPT₂'s cable and the mining machine's heading are

$$\theta_5 = \theta_3 + \cos^{-1} \left[\frac{r_3^2 + r_5^2 - r_7^2}{2r_3r_5} \right] \quad (5)$$

$$\text{and } \psi_3 = \pi - \pm \cos^{-1} \left[\frac{r_5^2 + r_8^2 - r_4^2}{2r_5r_8} \right] - \theta_8 + \theta_5, \quad (6)$$

respectively, and the mining machine's position is

$$x_{11} = r_1 \cos \theta_1 + r_5 \cos \theta_5 - r_{10} \cos(\theta_{10} + \psi_3) \quad (7)$$

$$\text{and } y_{11} = r_1 \sin \theta_1 + r_5 \sin \theta_5 - r_{10} \sin(\theta_{10} + \psi_3). \quad (8)$$

In the pair of three-transducer solutions that exclude LPT₂ data, the direction of LPT₃'s cable and the mining machine's heading are

$$\theta_6 = \theta_3 - \pi - \cos^{-1} \left[\frac{r_3^2 + r_6^2 - r_4^2}{2r_3r_6} \right] \quad (9)$$

$$\text{and } \psi_2 = \pm \cos^{-1} \left[\frac{r_6^2 + r_8^2 - r_7^2}{2r_6r_8} \right] - \theta_8 + \theta_6, \quad (10)$$

respectively, and the mining machine's position is

$$x_{11} = r_2 \cos \theta_2 + r_6 \cos \theta_6 - r_9 \cos(\theta_9 + \psi_2) \quad (11)$$

$$\text{and } y_{11} = r_2 \sin \theta_2 + r_6 \sin \theta_6 - r_9 \sin(\theta_9 + \psi_2). \quad (12)$$

In the pair of three-transducer solutions that exclude LPT₁ data, the direction of LPT₄'s cable and the mining machine's heading are

$$\theta_7 = \theta_3 - \pi - \cos^{-1} \left[\frac{r_3^2 + r_7^2 - r_5^2}{2r_3r_7} \right] \quad (13)$$

$$\text{and } \psi_1 = \pi - \pm \cos^{-1} \left[\frac{r_7^2 + r_8^2 - r_6^2}{2r_7r_8} \right] - \theta_8 + \theta_7, \quad (14)$$

respectively, and the mining machine's position is

$$x_{11} = r_2 \cos \theta_2 + r_7 \cos \theta_7 - r_{10} \cos(\theta_{10} + \psi_1) \quad (15)$$

$$\text{and } y_{11} = r_2 \sin \theta_2 + r_7 \sin \theta_7 - r_{10} \sin(\theta_{10} + \psi_1). \quad (16)$$

Equations 1 and 13 determine the mining machine's four-transducer solution heading to be

$$\psi = \tan^{-1} \left[\frac{r_4 \sin \theta_4 - r_7 \sin \theta_7 - r_3 \sin \theta_3}{r_4 \cos \theta_4 - r_7 \cos \theta_7 - r_3 \cos \theta_3} \right] - \theta_8 \quad (17)$$

and position to be

$$x_{11} = r_1 \cos \theta_1 + r_4 \cos \theta_4 - r_9 \cos(\theta_9 + \psi) \quad (18)$$

$$\text{and } y_{11} = r_1 \sin \theta_1 + r_4 \sin \theta_4 - r_9 \sin(\theta_9 + \psi). \quad (19)$$

Using quadrant information yielded by the x and y scalar equations avoids multiple solutions caused by the inverse tangent function in equation 17.

IMPLEMENTATION

Reducing the MPHS theory to practice required the development of hardware, software, and system interfaces.

Hardware

The hardware configuration consists of LPT's, mounts, cabling, and a computer enclosure (fig. 6).

Each Rayelco³ P-750A LPT has a housing, a constant-force spring-driven takeup drum, 19.05 m (750 in) of wire, a gear reducer, and a 500- Ω potentiometer. The potentiometer resistance at the wiper is proportional to the length of wire played off from the takeup drum. Placing an excitation voltage across the potentiometer converts the wiper resistance into an output voltage.

The LPT's are mounted in pairs on either side of the mining machine. The mounts are adjustable for different roof heights in the entry (fig. 7). The mount design allows the LPT wires on one mount to slide over the top of the other mount, as happens when the machine turns a cross-cut. The wires from each LPT pair attach to two widely separated stationary points behind the mining machine near the roof and each rib. Since the LPT wires sag less than a few centimeters over their fully extended length, keeping them close to the roof reduces possible interference with haulage and other equipment.

Locating the computer enclosure in the cab allows the MPHS connecting cables to be short. The LPT circuits (fig. 8) are intrinsically safe (IS). Thus, riser-flame-tested, three-pair shielded cable with standard 97 series connectors is permissible. The LPT cables link the LPT's to the computer enclosure (fig. 9). The LPT and user interface connector (UIC) cables enter the computer enclosure through five explosion-proof (X/P) packing glands. A Line Power 30-3301-25 X/P connector joins the UIC cable to a Joy 14CM or 16CM mining machine. These mining machines are the Bureau's testbeds for computer-aided mining machine experiments. A 19.05-mm (3/4-in) mine conduit hose sheaths the UIC cable.

The MPHS controller is enclosed in an Ocenco X/P 2387 computer enclosure (fig. 10). The computer enclosure contains the battery, battery charger, and power supply. A 12-V, 12-A·h gell-cell allows self-contained operation of the MPHS. A 12-V dc/dc converter (rated at ± 12 V at 310 mA and +5 V at 1.5 A) provides power to the controller and LPT circuits. Applying ac through the UIC while the mining machine is in fresh air provides power to the battery charger. An X/P switch on top of the computer enclosure selects the *run*, *charge*, and *off* states. An MPHS current draw of 1.26 A at 12 V limits operation to about 9 h of continuous use.

The computer enclosure also contains the IS barriers and controller. Twelve STAHL 9001/02-175-050-00 IS barriers make the four LPT circuits IS. The controller's analog-to-digital (A/D) converter reads the LPT output voltages, which range from -4.5 to +4.5 V. The MPHS controller is an Intel iRCB 44/20A Analog I/O Controller.

³Reference to specific products does not imply endorsement by the U.S. Bureau of Mines.

An Intel iSBX 331 Fixed/Floating-Point Math Multi-module Board occupies the controller's iSBX connector and performs the floating-point math required by the MPHS algorithm. The MPHS controller communicates through the UIC using Intel's Bitbus network on a four-wire RS485 protocol interface.

Software

Writing the software in the computer languages PL/M-51 and ASM-51 instead of a higher level language reduces code size and increases code efficiency. The MPHS software has a node specification, task structure, and algorithm.

The node specification reflects the protocol, defined by the Bureau of Mines Network (BOM/NET), for communication with the MPHS node.⁴ This node specification defines syntax for requesting data or status, issuing commands, and interpreting responses. Communications with the MPHS contain data requests, control commands, and status requests.

Data requests allow the requestor to get data on any of three levels. The highest level returns the x position, y position, heading, status, and confidence, in engineering units. The next level returns the lengths of the LPT's in engineering units for independent calculation of the position and heading. The lowest level returns the raw A/D converter 12-bit output for independent conversion into engineering units and calculation of position and heading. These various levels allow the system to operate if the iSBX 331 math board malfunctions and also allow independent proof of the MPHS integrity.

Control commands allow the requestor to change the node's state or some of the variables used in calculation of the position and heading. One command resets the node if it malfunctions. Another command makes updating of the calibration information (slope and intercept of the calibration curve) for each LPT possible, thereby increasing the flexibility and accuracy of the system by using the individual calibration curves instead of requiring a default generic calibration curve. A command is also available to determine the offset of the LPT to its zero position. Subtracting the offset (as shown in equation 20) from the LPT length during the position and heading accounts for offsets due to the transducer mounts:

$$\text{distance} = [(\text{reading} - \text{intercept}) / \text{slope}] - \text{offset}. \quad (20)$$

⁴BOM/NET is an integrated distributed microcomputer control network. Network design for the Joy 14CM mining machine will be the subject of a future Bureau report.

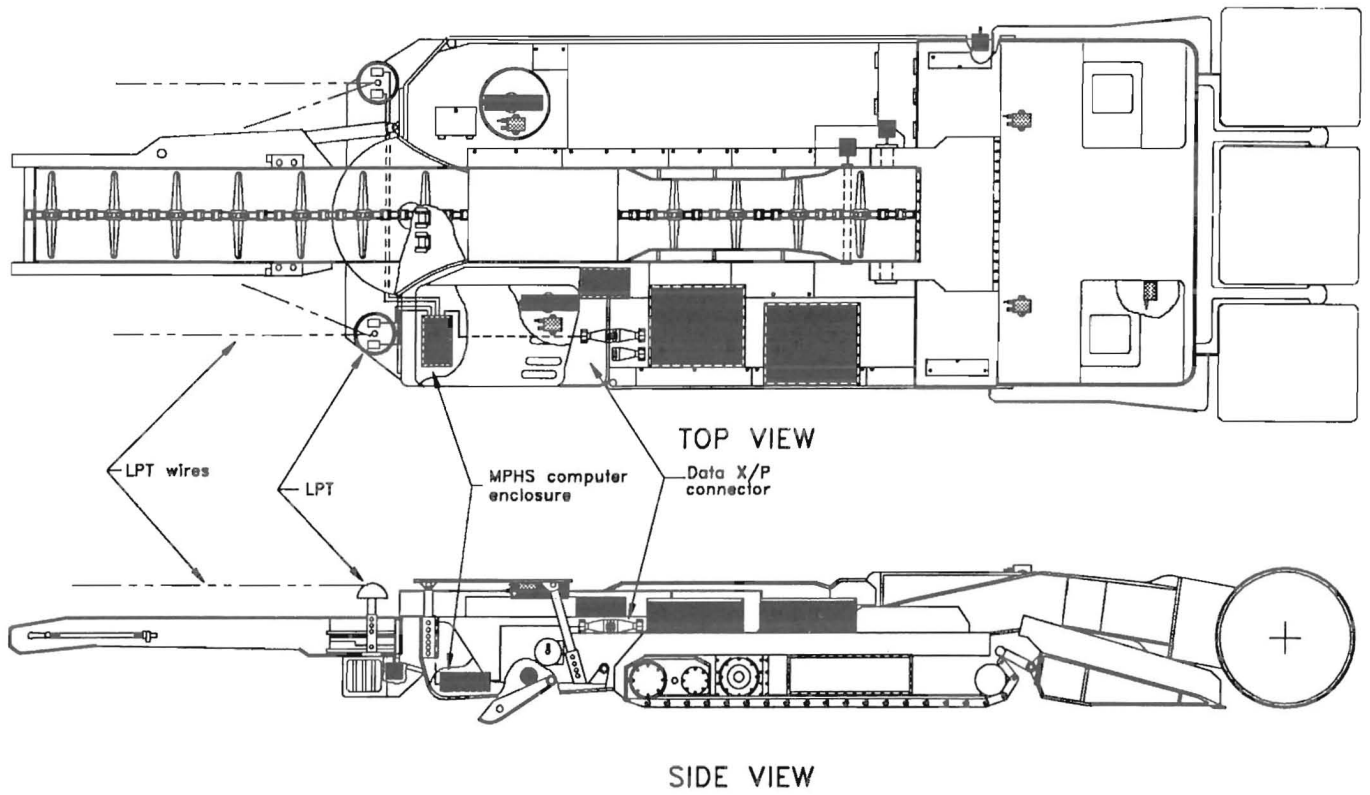

Figure 6.—Location of sensors, cables, and computer enclosure on Joy 14CM mining machine.

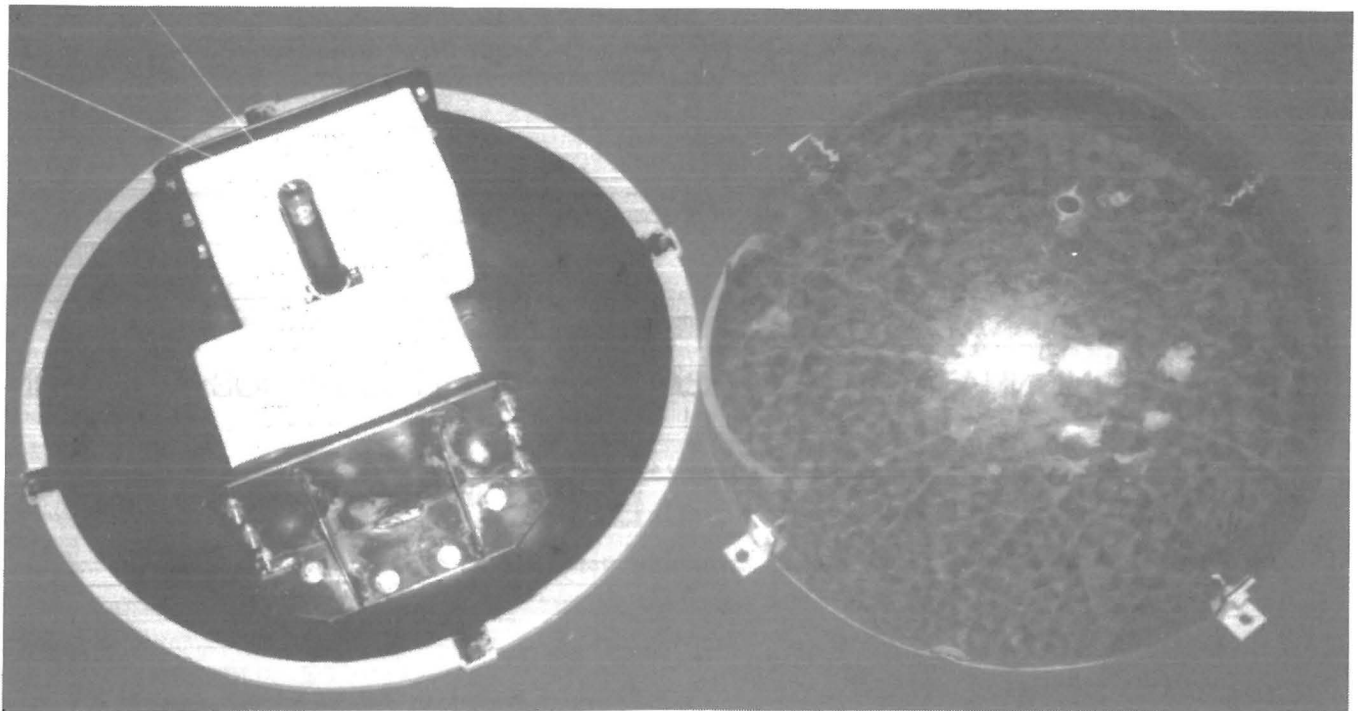

Figure 7.—LPT mounts for MPHS. Left, LPT mount and wire guide; right, protective polycarbonate dome.

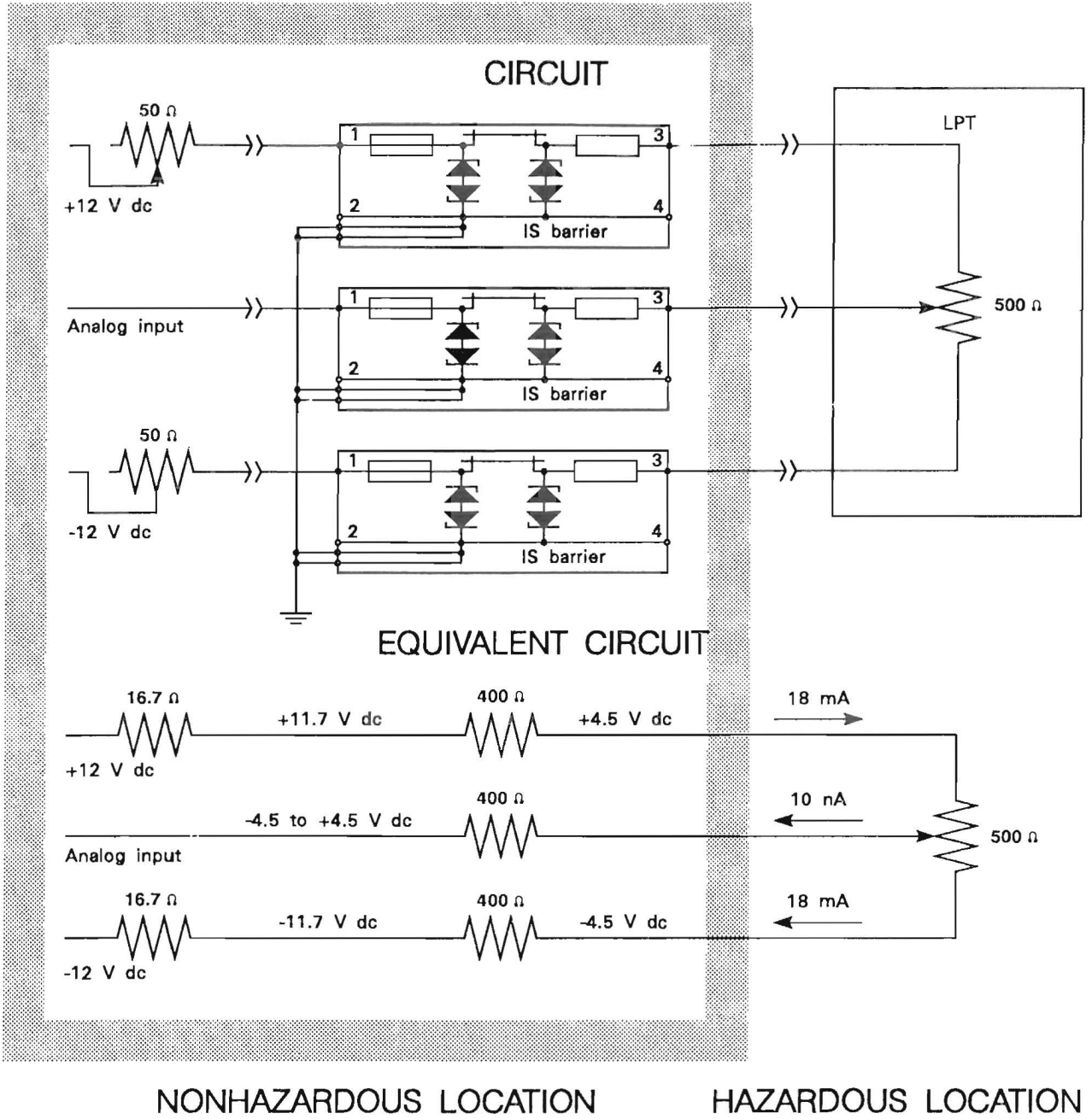

Figure 8.—Intrinsically safe LPT circuit for MPHS.

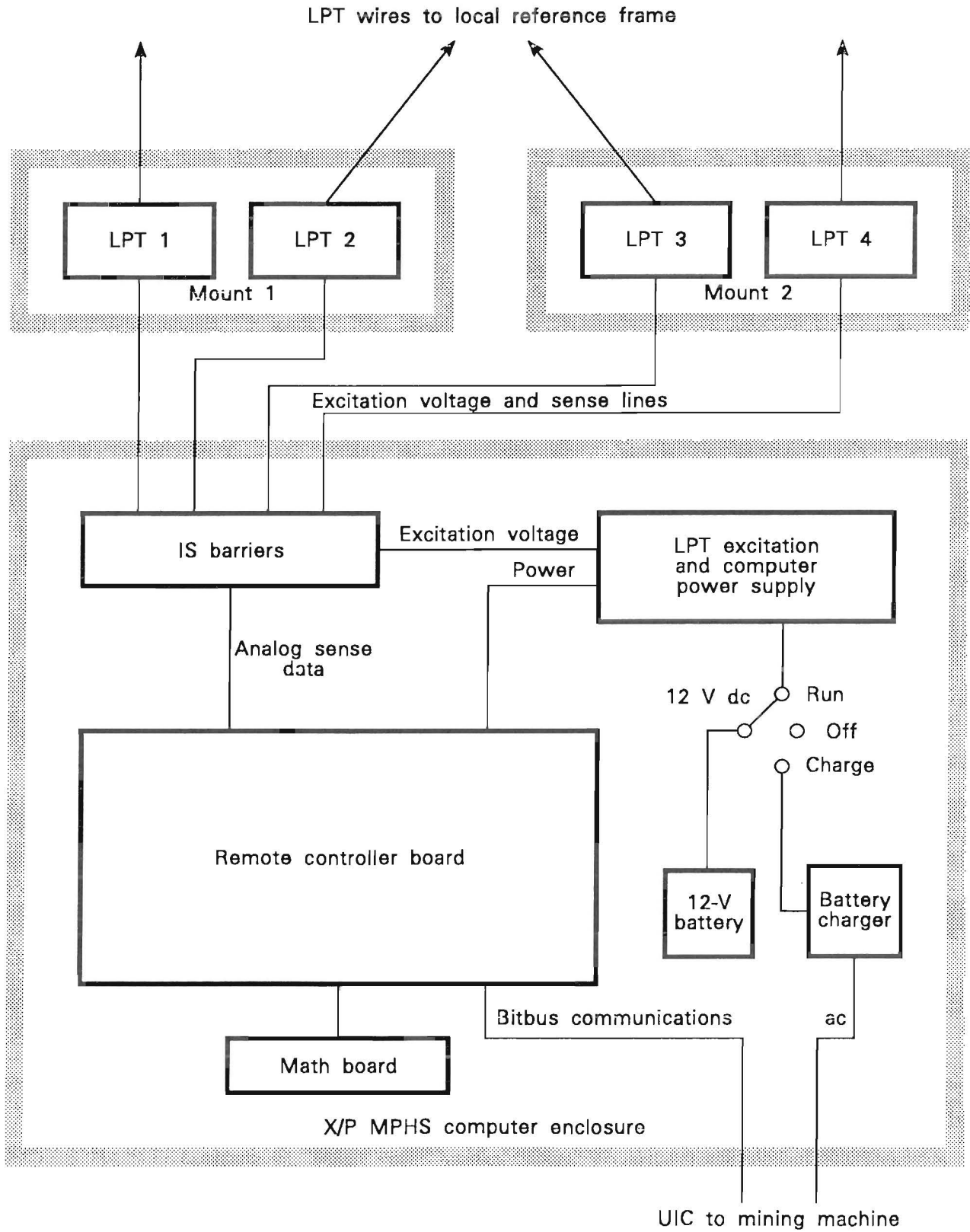

Figure 9.—Block diagram of MPHS computer enclosure.

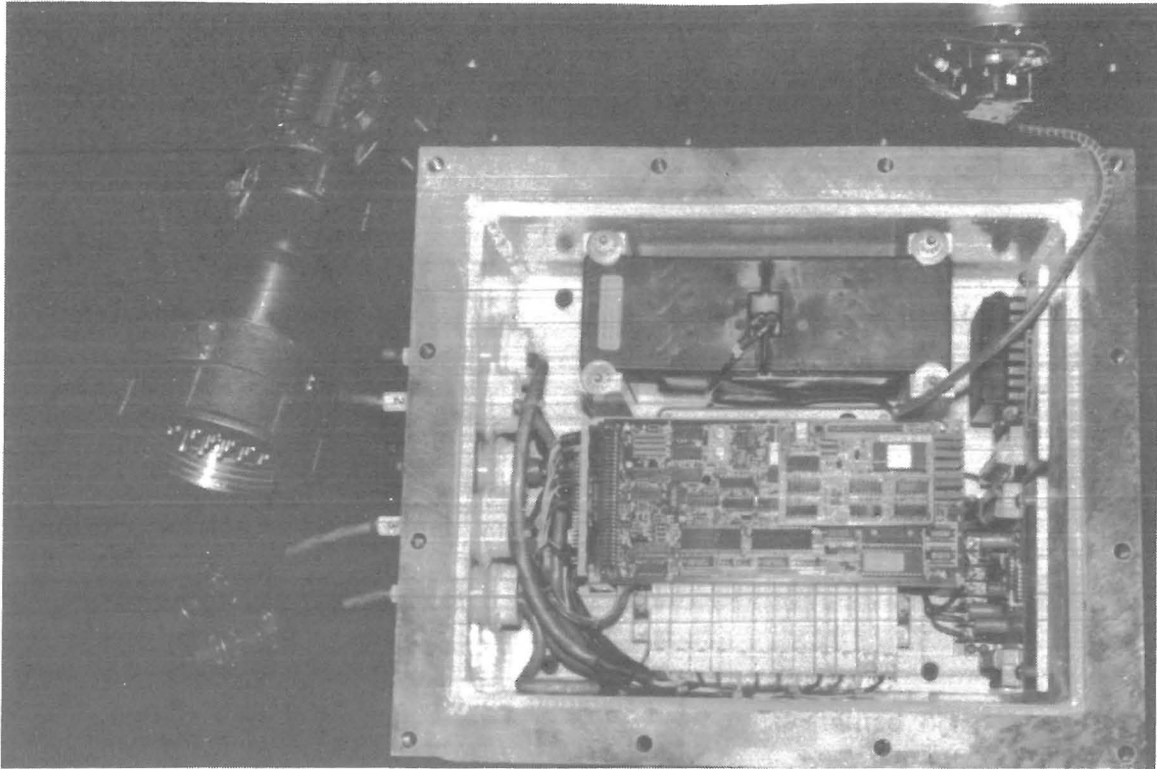

Figure 10.—MPHS computer enclosure chassis.

Finally, there are control commands that change the locations of the LPT's and attachment points in the mining machine and local reference frames, allowing flexibility in mounts and attachment points, depending on the constraints and configuration for operation, or attachment to different machines.

The status requests allow the requestor to determine the status of the MPHS node. Issuing a communications status check will determine if the MPHS node is in operation. Reading the status of the sensors determines if there is a range error or bad transducer. Reading the node status determines if a processing error has occurred, the numeric coprocessor has failed, or the A/D converter is inaccurate.

The MPHS node software operates in Intel's iDCX 51 real-time multitasking environment. Thus, the three tasks required by the software can run simultaneously: communications handling, command handling, and position and heading calculation (fig. 11).

The communications handler receives message packets addressed to the MPHS node. If the packet contains information for the MPHS node, the handler removes it and returns an empty message packet. Then the communications handler signals the command handler that there is information waiting for it to process. On the

other hand, if no information is present in the message packet, the handler loads the message packet with outgoing information, if any. The communications handler then signals the command handler that it can send more information.

The command handler transfers information to and from both the communications handler and the position and heading calculator. It parses the information received from the communications handler to determine if it is a data request, control command, or status request (fig. 12). If it is a request for data or status, the command handler queues the proper information from its data base for output to the communications handler. If the information is a control command, the command handler passes the proper information to the position and heading calculator. A control command calling for the reinitialization of the MPHS resets the MPHS parameters and restarts the software.

The position and heading calculator updates its data base with calibration, zeroing, attachment location, and transducer location information received from the command handler (fig. 13). It continuously performs position and heading calculations and updates the position, heading, status, and confidence in the data base held in common with the command handler. If the position and heading calculator does not receive information from the command

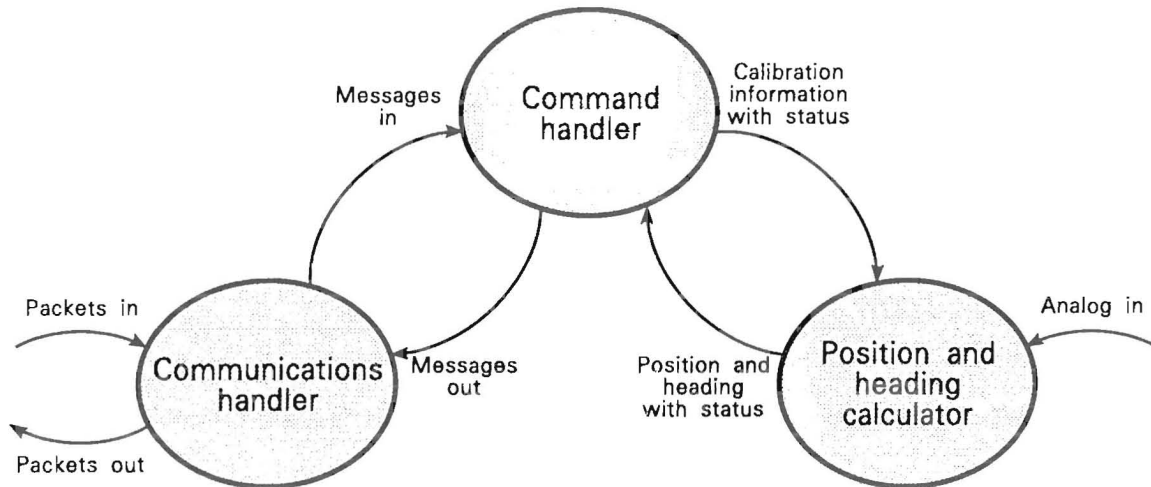

Figure 11.—Data flow diagram for Bitbus node tasks.

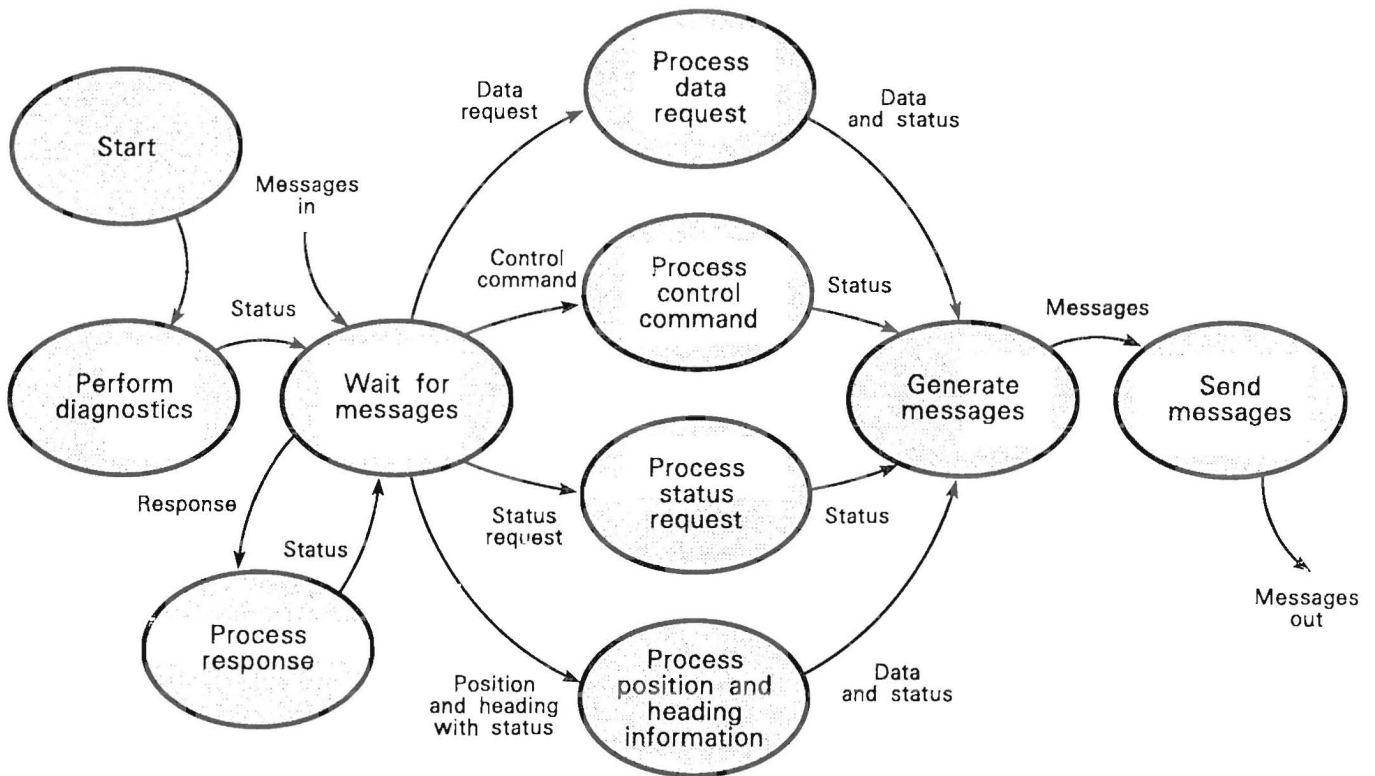

Figure 12.—Data flow diagram for command handler task.

handler, it uses default settings. These settings make possible calculation of the position and heading at a rate of about 5 Hz.

The position and heading algorithm is a subset of the position and heading calculator task. It uses information gained by the position and heading calculator task to

calculate the position, heading, confidence, and error status. The algorithm first reads the A/D converter to get the raw LPT data. It uses calibration information to convert the raw data into engineering unit lengths. Subtracting the offsets from these lengths yields the LPT distance measurements. At this point, the position and

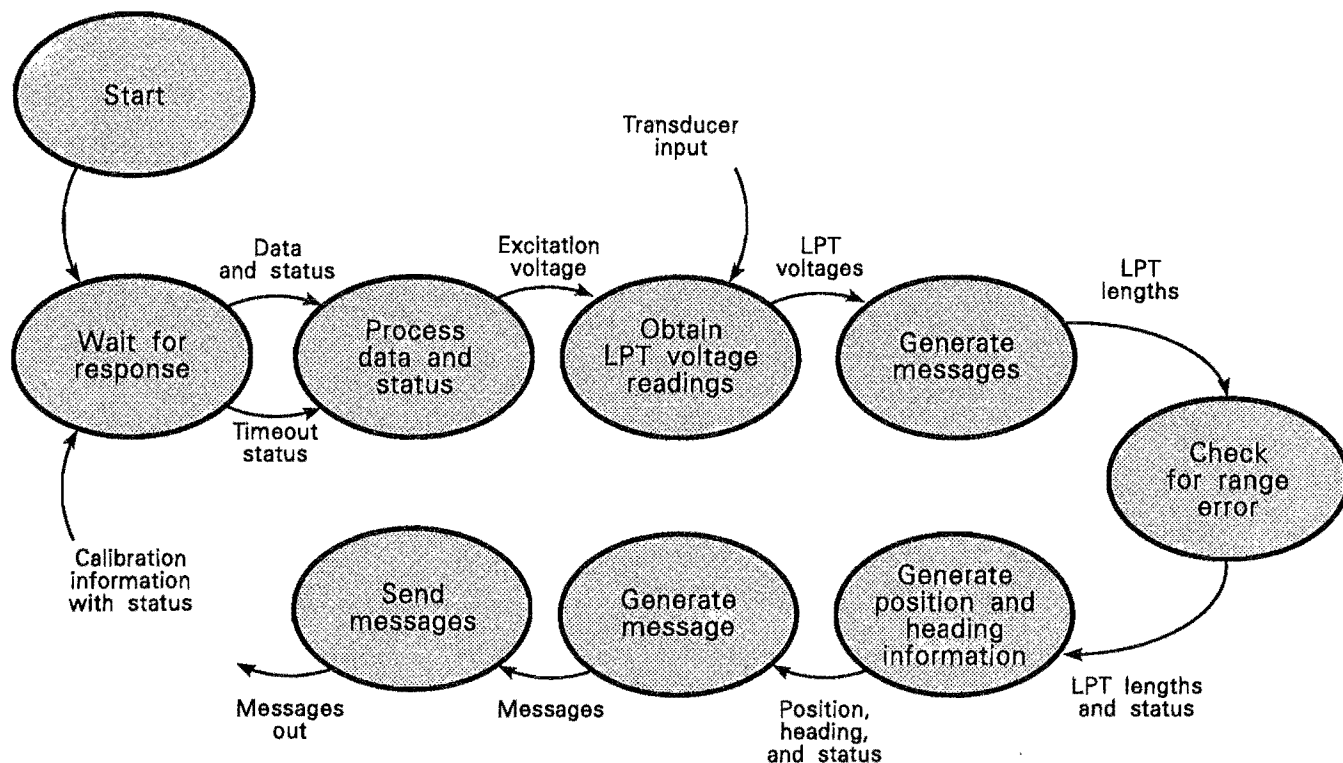

Figure 13.—Data flow diagram for position and heading calculator task.

heading calculator determines the internal angles and identifies any over- and under-range errors.

Since the number of LPT's in the MPHS provides redundancy, the position and heading calculations require only three of the available four LPT lengths, resulting in four three-transducer solution combinations and one four-transducer solution. Owing to ambiguities in the trigonometric solution, each three-transducer solution has a pair of results. Thus, the four-transducer solution helps determine which of each pair of three-transducer solutions is correct. *A priori* information (initial configuration, the sign of the angular rotation of the mining machine, mining machine commands issued, etc.) is available to aid this determination. However, using this information alone for error identification and confidence generation is inefficient since a simpler method is available.

To develop a confidence number for the solution and identify possible errors, the algorithm calculates the four pairs of three-transducer solutions and the one four-transducer solution. It selects the closest of each of the four pairs of three-transducer solutions to the four-transducer solution and averages them. Determining the average difference between this average and the four chosen three-transducer solutions allows the calculation of

a confidence. The average difference generates the confidence for the x, y, and heading values:

$$\text{confidence} = 1 - (\text{average difference} / \text{tolerance}). \quad (21)$$

The tolerances determining the confidence are 76.2 mm (3 in) for x and y and 0.0262 rad (1.5°) for the heading. The same values, used later, determine an accuracy value for the calculated position and heading.

If the confidence calculated for any of these three values (x, y, and heading) is less than zero, it becomes zero. The root-mean-squared (RMS) value of the three confidences yields the system confidence. If any confidences are zero, the system confidence is zero. If any processing errors occur during operation, the math module returns a system confidence of zero and an error status. If the confidence is nonzero, the position and heading calculator supplies its results to the command handler.

System

The MPHS is a BOM/NET node that can operate on either the Joy 14CM or 16CM mining machine networks. Figure 14 shows the MPHS node in BOM/NET as

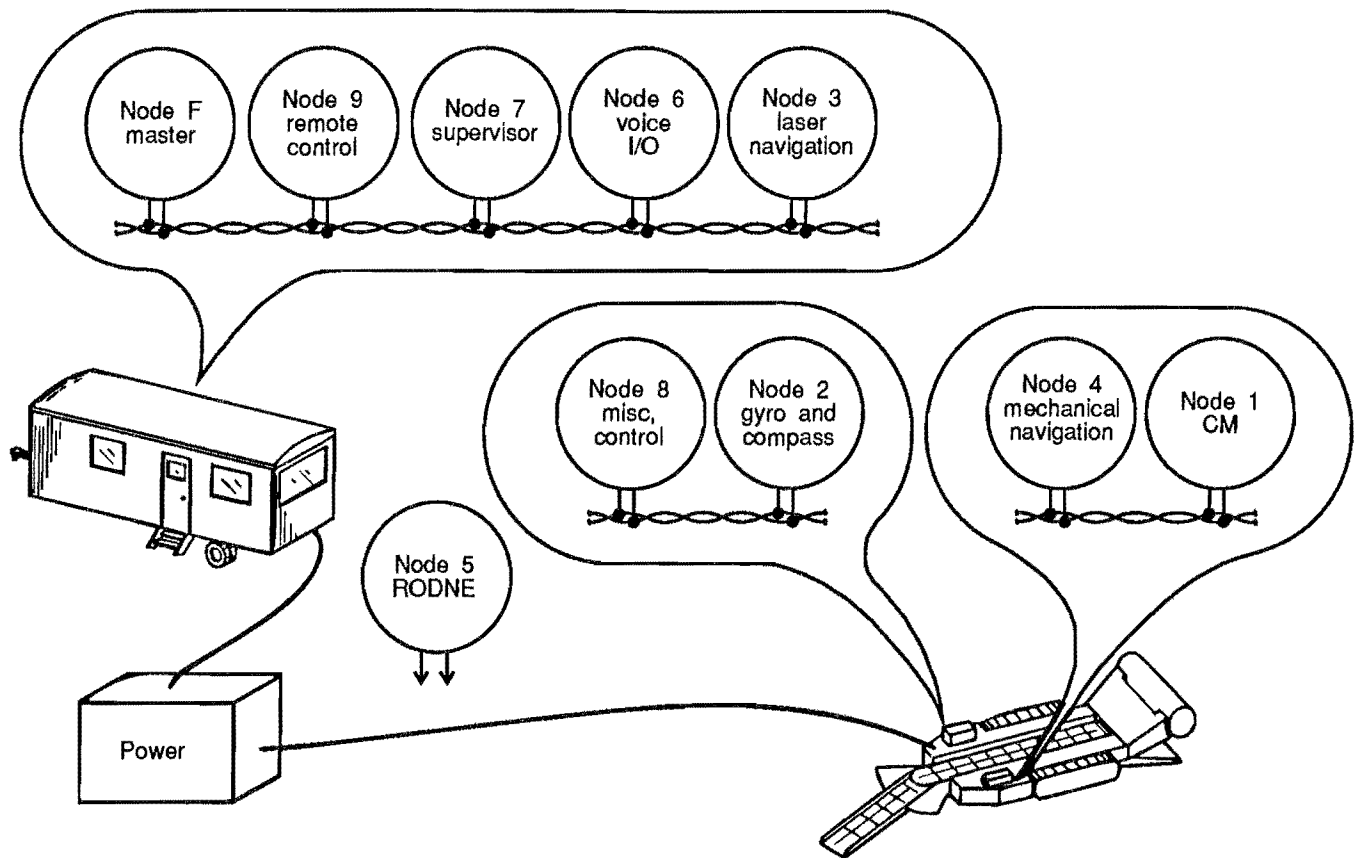

Figure 14.—BOM/NET for field trial system with Joy 14CM mining machine.

node 4—mechanical navigation. Other nodes perform tasks related to the computer-aided operation of the mining machine. The master node forms a pseudostar

network by passing all traffic between the nodes. Thus, any node requiring machine position and heading information can get it from the MPHS quickly.

ERROR ANALYSIS

When performing measurements that have an impact on safety, it is usually more important to know the data's reliability than the actual data themselves. Safety of personnel is extremely important in mining operations; therefore, ignorance of data reliability makes data less than useless (that is, dangerous). Sensor redundancy reduces the chance of an undetectable error to an insignificant level; however, the detectable errors affect the solution's accuracy.

Measurable, inherent errors exist in the sensors, A/D converter, and sample rate of the MPHS. The LPT's in the MPHS typically have a 0.1-pct full-scale (FS) accuracy, translating into ± 9.53 mm (0.375 in). The error introduced by a sag of 2.54 cm (1 in) over the length of 19.05 m (750 in), modeled by a catenary curve, is on the

order of 0.0254 mm (0.001 in) or 0.00013 pct FS and is thus ignored. The A/D converter used has a 0.035-pct FS error. Combining the A/D error with the LPT error in a root-sum-squared (RSS) manner yields a 0.106-pct FS error of ± 10.1 mm (0.397 in). A sampling rate of 5 Hz yields a 32.9-mm (1.30-in) and 0.0113-rad (0.646°) uncertainty for the Joy 16CM mining machine tramming characteristics (5).

Owing to the nature of the MPHS algorithm, these errors affect the solution's accuracy depending on the mining machine's position and heading. System error determination is, therefore, complex and employs three techniques: numerical analysis, algebraic analysis, and experimental analysis (see test results in the next section).

NUMERICAL ANALYSIS

A program written in the computer language C, simulating the MPHS with its inherent errors, performs several tasks. First, the program simulates the motion of a mining machine (5), using the appropriate tramping commands and calculating the resultant actual position and heading. Next, the simulator calculates the lengths of the LPT's for that mining machine's position and heading. Random errors within the sensor calibration limits introduced into the simulated LPT readings provide realistic errors in the data. The MPHS algorithm uses these simulated LPT readings to compute the mining machine's position and heading. The calculated position and heading, when compared with the actual position and heading, yields the MPHS error.

Performing numerical analysis while emulating two typical maneuvers yields a pattern that shows that the magnitude of the system error depends on the mining machine position and heading. In the first maneuver (fig. 15), the mining machine executed a 12.192-m (40-ft) forward advance (as if traversing an entry). For the second maneuver (fig. 16), the mining machine turned a 1.571-rad (90°) left crosscut and advanced 6.096 m (20 ft). The confidence for the advance test simulation is within 18 percentage points of the accuracy, with a standard

deviation of 5 percentage points. The confidence for the crosscut test simulation is within 8 percentage points of the accuracy, with a standard deviation of 13 percentage points. The nonzero confidences and accuracies show that the system error is within the tolerance, ± 76.2 mm (3 in) in the x and y position and ± 0.026 rad (1.5°) in the heading, used to calculate the confidence.

ALGEBRAIC ANALYSIS

The standard method for computing the combination of component errors in system-accuracy calculations for the MPHS algorithm is complex (6). This method requires taking the partial derivatives of the x, y, and heading equations with respect to each of the four LPT lengths, resulting in very lengthy equations, which are not included in this report. The method itself, however, is straightforward:

1. Make a table of all data points, each with its plus-or-minus error attached.
2. To compute the x position determined by a three-transducer solution, where $x = f(r_1, \theta_1, r_3, \theta_3, r_4, r_5, r_6, \theta_8, r_9, \theta_9)$, take the partial derivatives $\partial f / \partial r_4$, $\partial f / \partial r_5$, and $\partial f / \partial r_6$ and evaluate the function by substituting the values of r_4 , r_5 , and r_6 .

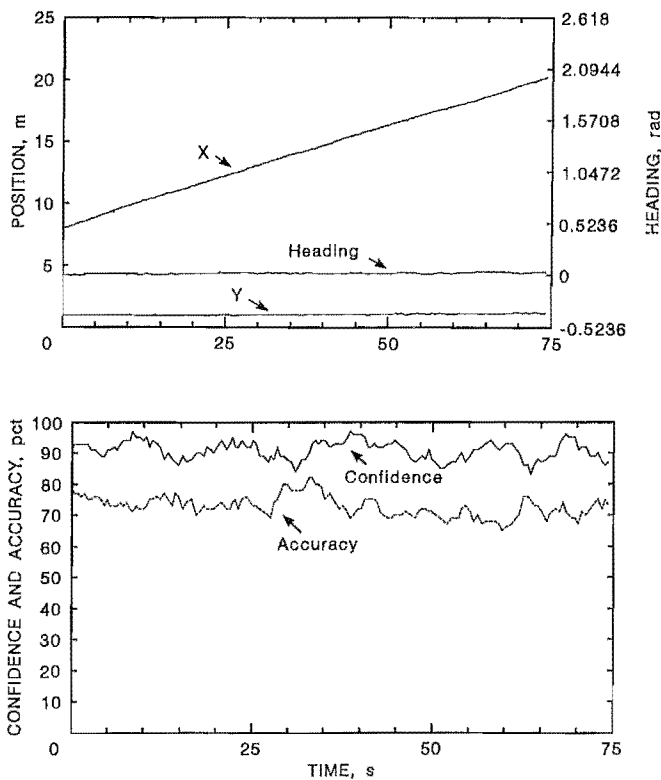

Figure 15.—Results of advance numerical simulation.

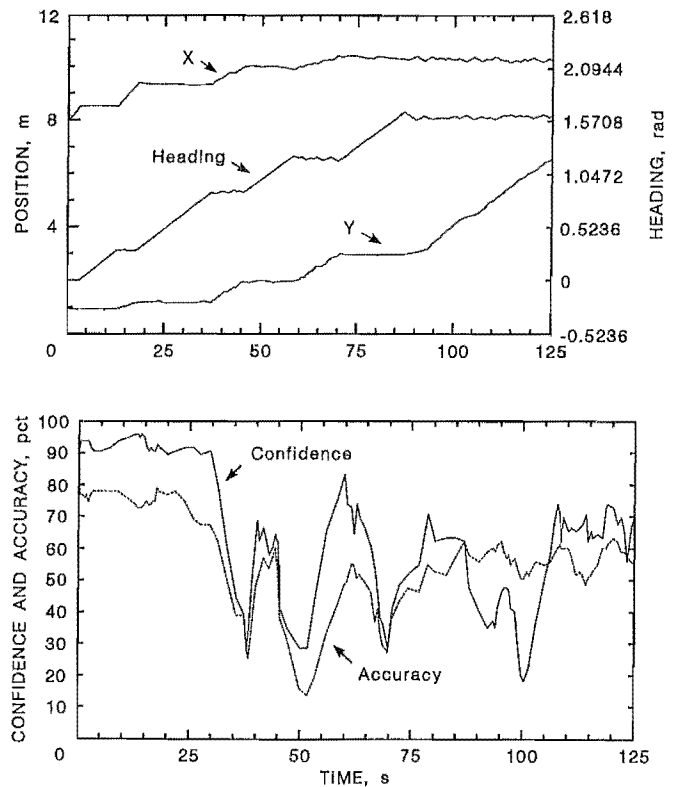

Figure 16.—Results of crosscut numerical simulation.

3. Compute

$$E_{a_{RSS}} = \sqrt{(\Delta r_4 \cdot \partial f / \partial r_4)^2 + (\Delta r_5 \cdot \partial f / \partial r_5)^2 + (\Delta r_6 \cdot \partial f / \partial r_6)^2} \quad (21)$$

$E_{a_{RSS}}$, here, is the systemic error in RSS absolute terms for the configuration described by r_4 , r_5 , and r_6 . The systemic

error is close to the error predicted by the numerical method and varies with the position and heading (7).

TESTING THE MECHANICAL POSITION AND HEADING SYSTEM

Testing the MPHS proved the concept and its implementation and feasibility. Testing the MPHS involved designing experiments, determining experimental procedures, and collecting and analyzing experimental test results.

SURFACE TESTING

The MPHS surface tests occurred in the Bureau's Pittsburgh Research Center mining equipment test facility. These tests confirmed operation of the MPHS under controlled, but fairly realistic conditions.

Setup

A wood mockup (fig. 17) of a mobile control structure provided an attachment point for two pairs of wires and the stationary local reference frame for the MPHS. The LPT mounts attached to the rear of either the Joy 14CM or Joy 16CM mining machine. The operator's cab of the mining machine housed the computer enclosure. A laser transit was used to provide accurate position and heading data for determining MPHS accuracy. (The accuracy of the laser transit is 3.175 mm (0.125 in) and 0.00002424 rad (5"), respectively.)



Figure 17.—Joy 14CM mining machine configured for MPHS surface tests.

Procedure

MPHS accuracy was examined for two typical machine maneuvers. In the first maneuver, the mining machine executed a 12.192-m (40-ft) forward advance (as if traversing an entry). For the second maneuver, the mining machine turned a 1.571-rad (90°) left crosscut and advanced 6.096 m (20 ft). Each maneuver was accomplished by manually tramping the mining machine for about 1 s. Transit and MPHS data were collected during each pause. Then, MPHS data were normalized with respect to time for better analysis by using the tramping characteristics of the mining machines to calculate the time intervals between the data points.

Results of Joy 14CM and Joy 16CM Mining Machine Tests

Figures 18 through 21 show the results of the Joy 14CM and 16 CM mining machine experiments. The top graph in each figure shows the position and heading information, provided by the MPHS, during each experiment. The bottom portions of these figures show the transit measured accuracy versus the MPHS calculated confidence.

Examination of the confidence and accuracy data resulting from all four experiments shows several interesting results:

- The confidence of the Joy 14CM mining machine advance test is within 4 percentage points of the accuracy, with a standard deviation of 11 percentage points. The confidence of the Joy 14CM mining machine crosscut test is within 6 percentage points of the accuracy, with a standard deviation of 14 percentage points. The confidence of the Joy 16CM mining machine advance test is within 8 percentage points of the accuracy, with a standard deviation of 8 percentage points. The confidence of the Joy 16CM mining machine crosscut test is within 4 percentage points of the accuracy, with a standard deviation of 19 percentage points. These relationships show that the confidence generator uses an effective computation method.

- There is a greater sensitivity to transducer errors at headings around 1.571 rad (90°). This expected sensitivity is due to the coupling of length variables in the position and heading equations.

- The x and y readings in figures 19 and 21 change during pivots because of the imperfect location of the mining machine's center of rotation and the slippage that occurs in the crawler tracks during the pivot.

- The confidences and accuracies of the MPHS are always above zero, demonstrating its reliable operation.

UNDERGROUND TESTING

Underground tests of the MPHS are planned to take place in 1991 to confirm that the MPHS operates under field conditions. The results are expected to be similar to those of the surface tests, with more slippage in the tramping functions.

Setup

The experiment will require that the LPT wires connect to posts mounted between the floor and roof of the entry (fig. 22). These posts provide attachment points for two pairs of wires and a stationary local reference frame for the MPHS. The LPT mounts attach to the rear of the Joy 14CM mining machine. The operator's cab of the mining machine houses the computer enclosure. A laser transit providing accurate position and heading data will supply a benchmark for the MPHS data.

Procedure

The experimental procedure devised will examine two cases. In the first case, the mining machine will execute a 12.192-m (40-ft) forward advance (as if traversing an entry). In the second case, the mining machine will turn a 1.571-rad (90°) left crosscut and advance 6.096 m (20 ft). Manually tramping the mining machine for about 1 s at a time while modeling each case will allow data collection. Data collection via a transit and the MPHS will occur during each pause.

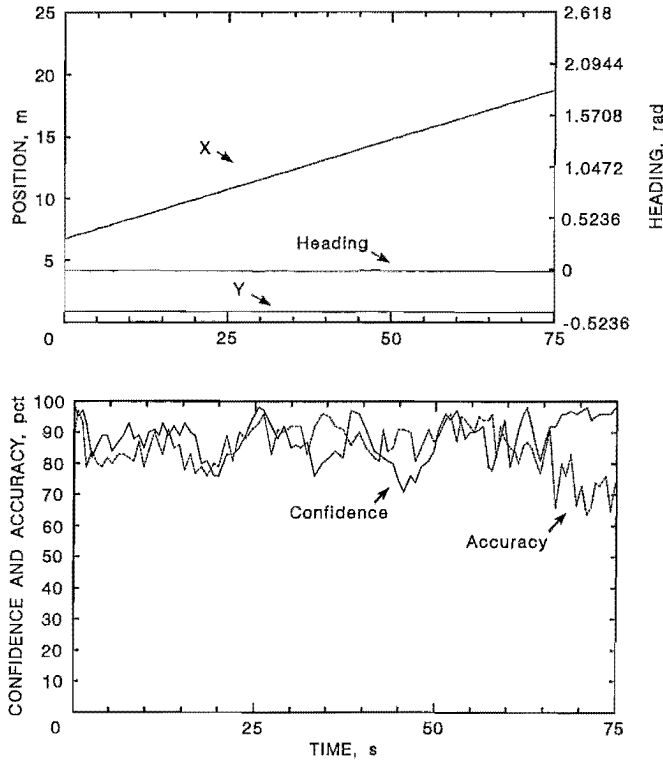

Figure 18.—Data for Joy 14CM mining machine surface advance test.

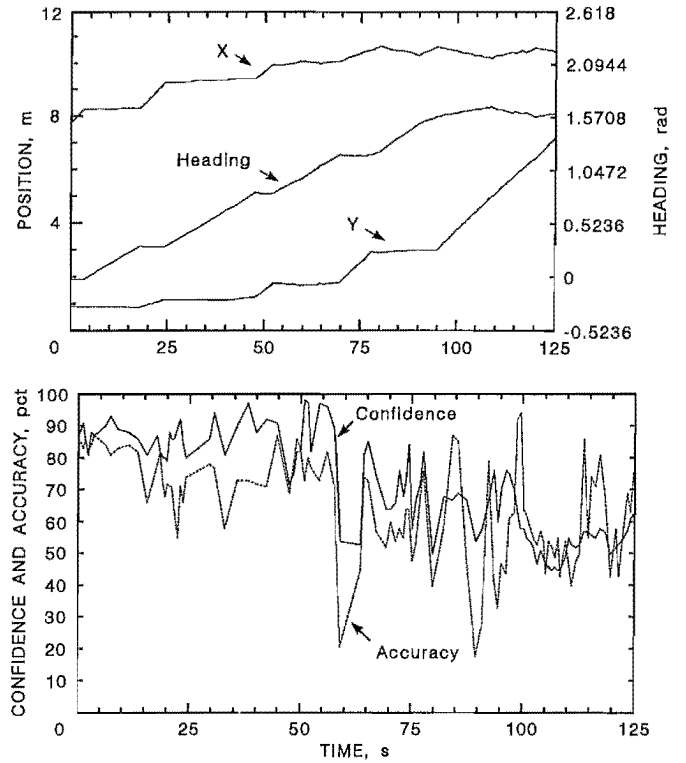

Figure 19.—Data for Joy 14CM mining machine surface crosscut test.

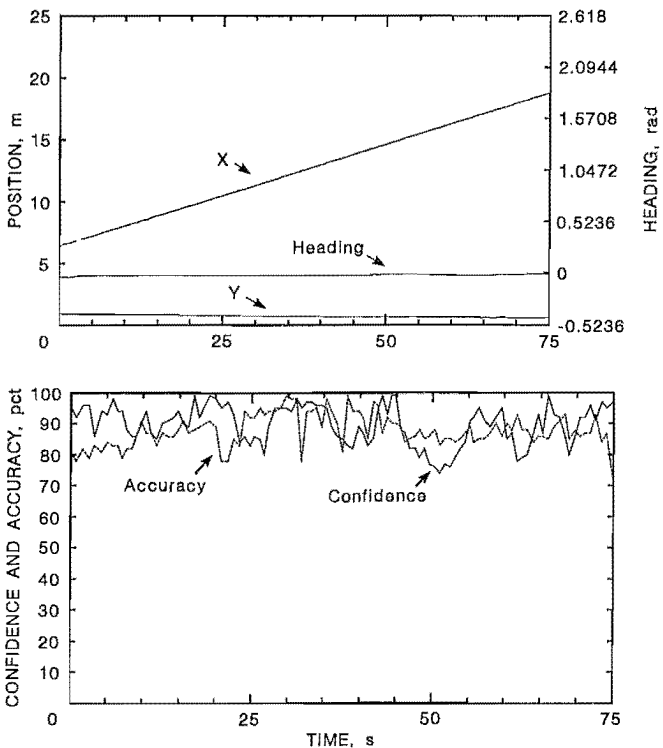

Figure 20.—Data for Joy 16CM mining machine surface advance test.

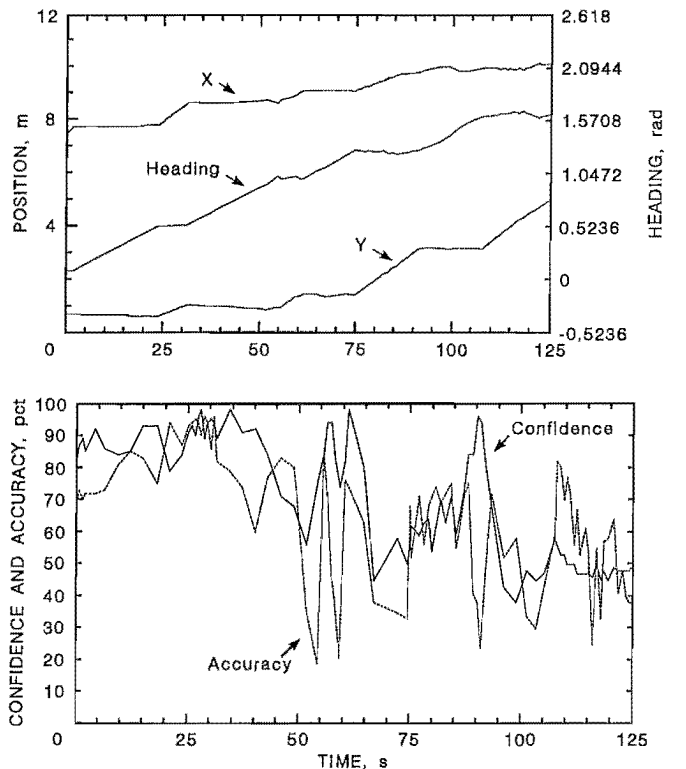

Figure 21.—Data for Joy 16CM mining machine surface crosscut test.

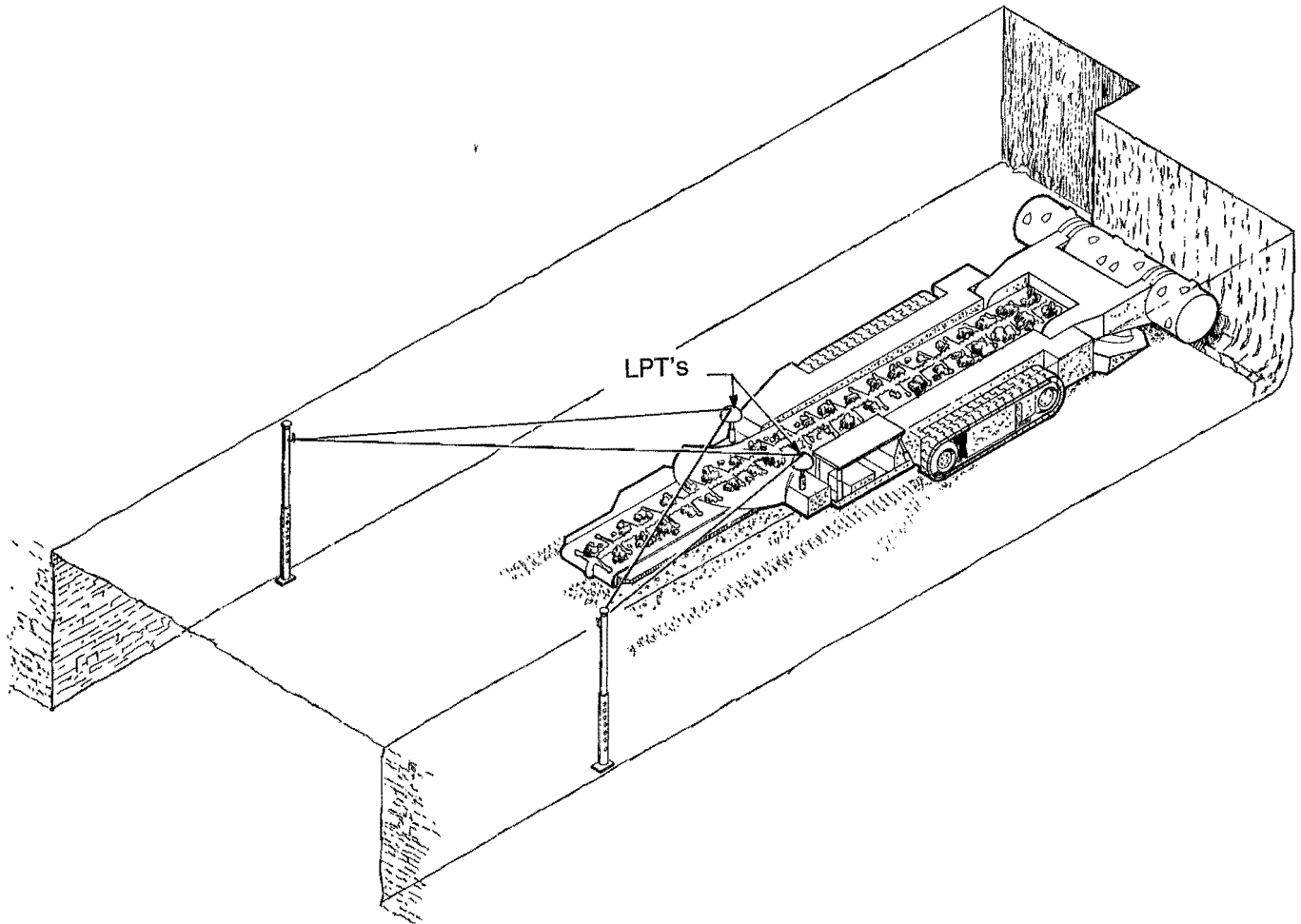

Figure 22.—Configuration for MPHS underground tests.

CONCLUSIONS AND RECOMMENDATIONS

The MPHS developed by the Bureau works reliably in surface tests. The MPHS yields position, heading, status, and confidence data in response to LPT data. The confidence supplied with each position and heading calculation reflects the actual system accuracy. The system accuracy is better than ± 76.2 mm (3 in) in the x and y position and ± 0.026 rad (1.5°) in the heading. The advance and crosscut tests verified this accuracy. The tests show the system accuracy to depend on the position and heading of the mining machine and the LPT input errors. While the errors incurred by the MPHS may be acceptable in a mining environment, better LPT transducers are available to improve accuracy. Underground tests are expected to further validate the system in 1991.

The researchers propose several recommendations for future study of the MPHS. The first is to either obtain

more accurate LPT's or better characterize their inherent errors. Better length data will yield more accurate results. Second, while the LPT mounts worked well for the tests performed, modifying the mounts could extend LPT wire life and further increase LPT measurement accuracy. Third, a controller with more processing capability would proportionally decrease the calculation delay times and make the MPHS more suitable for real-time control applications. Finally, a more accurate method to determine the exact position and heading of the mining machine would yield a more accurate representation of MPHS accuracy. The laser transit, while accurate enough for most tasks, showed some limitations (accuracy in distance and heading) during testing.

REFERENCES

1. Schnakenberg, G. H., Jr. Computer-Assisted Continuous Coal Mining System—Research Program Overview. BuMines IC 9227, 1989, 15 pp.
2. Anderson, D. L. Framework for Autonomous Navigation of a Continuous Mining Machine: Face Navigation. BuMines IC 9214, 1989, 23 pp.
3. British Coal, Headquarters Technical Department (Burton-on-Trent, England). Alignment and Profile Guidance of Roadheaders. Final rep. on European Coal and Steel Community Res. Proj. 7220-AB/810, 1987, 45 pp.
4. Jobes, C. C. Utilizing Mechanical Linear Transducers for the Determination of a Mining Machine's Position and Heading: The Concept. BuMines IC 9254, 1990, 16 pp.
5. Sammarco, J. J. Closed Loop Control for a Continuous Mining Machine. BuMines RI 9209, 1988, 17 pp.
6. Doebelin, E. O. Measurement Systems: Application and Design. McGraw-Hill, 3d ed., 1983, pp. 58-67.
7. Horst, J. An Application of Measurement Error Propagation Theory to Two Measurement Systems Used To Calculate the Position and Heading of an Autonomous Vehicle Moving on a Flat Surface. Natl. Inst. Stand. and Technol. IR, 1990, 45 pp.