

Analysis of Different Low Complexity Nonlinear Filters for Acoustic Echo Cancellation

Andrea Fermo¹, Alberto Carini² and Giovanni L. Sicuranza¹

¹D.E.E.I., University of Trieste, Italy

²Telit Mobile Terminals S.p.A., Sgonico (Trieste), Italy

Linear filters are often employed in most signal processing applications. As a matter of fact, they are well understood within a uniform theory of discrete linear systems. However, many physical systems exhibit some nonlinear behaviour, and in certain situations linear filters perform poorly.

One case is the problem of acoustic echo cancellation, where the digital filter employed has to identify as close as possible the acoustic echo path that is found to be highly nonlinear. In this situation a better system identification can be achieved by a nonlinear filter. The problem is to find a nonlinear filter structure able to realize a good approximation of the echo path without any significant increase of the computational load. Conventional Volterra filters are well suited for modelling that system but they generally need too many computational resources for a real time implementation.

In this paper we consider some low complexity nonlinear filters in order to find out a filter structure able to achieve performances close to those of the Volterra filter, but with a reduced increase of the computational load in comparison to the linear filters commonly employed in commercial acoustic echo cancellers.

Keywords: acoustic echo cancellation, nonlinear filters, Volterra filters

1. Introduction

The growth of the cellular phone market in the last years has led to an increase on the quality of handset receivers. In particular, the quality of the audio is one of the features the cellular vendors take in high consideration. One issue related to the audio quality is the need for an acoustic echo suppression device which eliminates the feedback of the far end speech signal that propagates between the loudspeaker and the microphone.

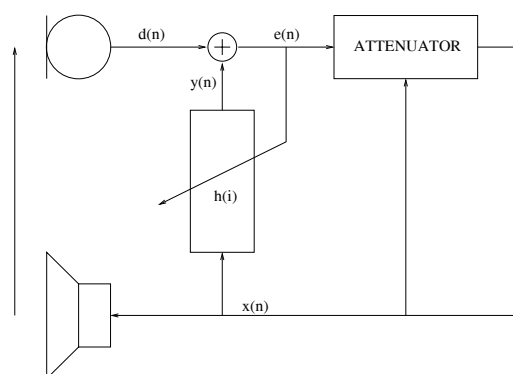

Fig. 1. Acoustic echo canceller.

Acoustic echo cancellers (AECs) (Figure 1) are the solution commonly employed for this purpose. They consist of digital adaptive filters which estimate the echo signal in order to cancel it by subtraction. Usually most commercial AECs are linear, even though it has been found that the acoustic echo path is highly nonlinear [1]. The nonlinearities arise mainly from nonlinear distortions of the loudspeaker and the amplifier and from nonlinear effects in vibrations of the enclosure. In this situation often a nonlinear filter can achieve a better system identification (and, by consequence, a greater echo suppression) than a linear one. In particular, it has been found that with a second order Volterra filter a significant improvement in acoustic echo cancellation can be achieved [2]. However, in most cases the implementation of these filters is computationally expensive due to the large number of coefficients required for representing the system. In fact, the AEC filter memory should have the same length of the acoustic

echo path response, which is commonly very long (with a sampling rate of 8 kHz, we have impulse responses typically of 128 samples for handset receivers, 256 samples for handsfree receivers and 1024-2048 samples for teleconference systems).

Here we study different nonlinear filters in order to find a low complexity structure able to model the nonlinear acoustic echo path with a low number of coefficients. In particular, we consider MMD filter structures [3], Parallel-Cascade structures [4], Simplified Volterra Filters [5] and bilinear Volterra filters [6].

The paper is organized as follows: in Section 2 we briefly describe Volterra filters. In Section 3 we describe the low complexity filter structures we have studied, and we analyze the behaviour of these filters on the perspective of the implementation of an acoustic echo canceller. In Section 4 we present some experimental results that were obtained in acoustic echo cancellation applications.

2. Volterra Filters

The Volterra series is expressed by [7]:

$$y(n) = \sum_{k=1}^{\infty} \hat{h}_k[x(n)] \quad (1)$$

where

$$\hat{h}_k[x(n)] = \sum_{i_1=0}^{\infty} \cdots \sum_{i_k=0}^{\infty} h_k(i_1, \dots, i_k) x(n-i_1) \cdots x(n-i_k) \quad (2)$$

is the k th-order Volterra operator. Volterra filters are nonlinear filters resulting from double truncation of the Volterra series: a memory truncation, by limiting the memory of the filters, i.e. the number of terms in the summations in (2), and an order truncation by limiting the number of Volterra operators in (1).

The quadratic filters are a special case of Volterra filters that involve only two terms of the summation of (1). The filter output can be expressed in vector form as:

$$y(n) = \mathbf{h}_1^T \mathbf{x}(n) + \mathbf{x}^T(n) \mathbf{H} \mathbf{x}(n) \quad (3)$$

where \mathbf{h}_1 is the vector formed with the coefficients of the linear filter, \mathbf{H} is the upper triangular matrix [7] representing the second order Volterra kernel, and $\mathbf{x}(n)$ is the vector of the past input samples. Although Volterra filters are well suited for echo path modelling, the computational requirements even for a second order filter are too high for a real-time application as AEC. While the implementation of a linear adaptive filter requires a number of multiplications proportional to N (where N is the memory of the filter which is strictly related to the length of the acoustic echo path), the implementation of a quadratic filter requires a number of multiplications proportional to N^2 . In acoustic echo canceller applications, N is often greater than 100 and the computational load becomes really high. For this reason some low complexity nonlinear filters have been proposed in the last years. We considered some of them and we analyzed their capability to be implemented in a commercial AEC.

3. Low Complexity Nonlinear Filters

Let us consider the *Multi-Memory-Decomposition* (MMD) filter structure [3], realized by the interconnections of three linear filters, as reported in Figure 2. The output of the filter is given by:

$$y(n) = \sum_{k=0}^{N_p-1} h_p(k) \sum_{i=0}^{N_a-1} h_1(i) x(n-i-k) \sum_{j=0}^{N_a-1} h_2(j) x(n-j-k), \quad (4)$$

where N_a is the memory length of the filters h_1 and h_2 , and N_p is the memory length of the filter h_p . This MMD structure is a quadratic filter whose kernel matrix has nonzero coefficients only in N_a diagonals near the main diagonal [3]. The complexity associated with the implementation of this kind of filter is very low if compared to that of a Volterra filter. In particular, the number of multiplications needed is equal to $2N_a + N_p + 1$, and thus substantially proportional to the memory $N = N_a + N_p$ of the filter. However, the MMD structure can just roughly approximate the generic second order nonlinear system because of the low number of

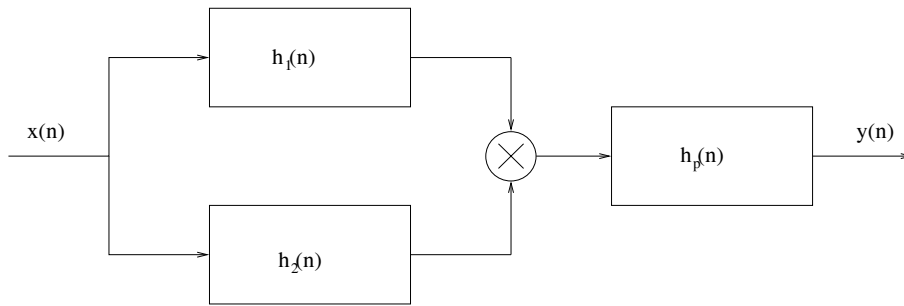

Fig. 2. MMD filter.

parameters involved. Furthermore, some problems arise with the adaptive version of that filter. In particular, the complexity significantly increases because of the adaptation procedure, and it becomes proportional to $N_a \times N_p$. Moreover, the adaptation procedure suffers from the existence of local minima due to the fact that the filter output is not linear with respect to its coefficients. For this reason the approximation achieved with that filter is not adequate.

3.1. Parallel-Cascade Filter

In Figure 3 the *Parallel Cascade* filter structure for a second order nonlinear system approximation is reported [4]. This structure is based on the assumption that any symmetric matrix of rank r can be decomposed in the sum of r symmetric matrices of order 1 [4]. This implies that a second order Volterra filter whose kernel matrix has rank equal to r can be realized by a parallel structure of r linear filters each one followed by a squaring function and a multiplier.

It is often possible to obtain a good approximation of the second order Volterra filter by implementing m (with $m \ll r$) linear filters in parallel [4]. In this way a significantly high computational saving is obtained.

Two problems arise with the adaptation procedure applied to this type of filter. The first one is that there is not a unique solution, and the filter coefficients can oscillate between the different solutions. The second one is the presence of some local minima. These local minima are caused by the fact that the output of the filter is not linear with respect to its coefficients.

One remedy for the first problem has been proposed [4]. It consists in constraining the first $i - 1$ coefficients of the i -th branch to zero and setting the i -th coefficient to 1. These coefficients do not need updating. The decomposition obtained in this way is called LDL^T decomposition. However, the second problem associated with the adaptive procedure of the filter remains still unresolved to the author's knowledge. For

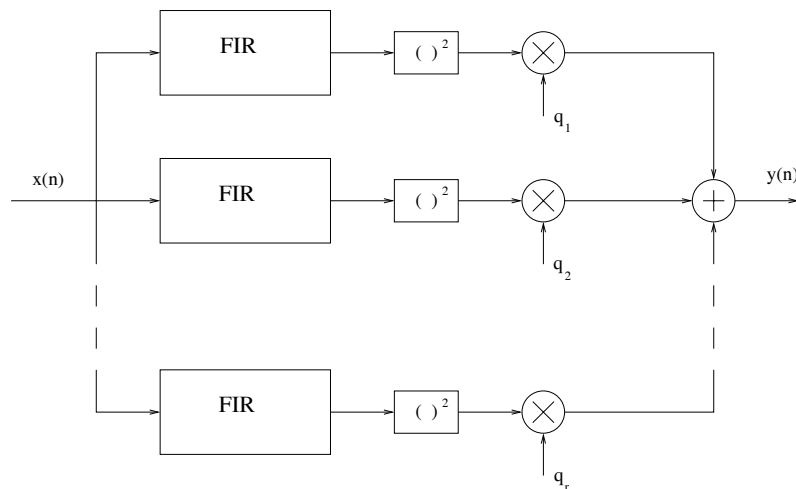

Fig. 3. Parallel-Cascade filter.

this reason the quality of the approximation we can reach is always limited, even when we implement a large number of branches.

3.2. Simplified Volterra Filters

By analyzing the second order kernel of several acoustic echo paths (an example is reported in Figure 4) we observe that the coefficients with the most significant amplitude lay on the diagonals near the main one. Similar behaviours have been found by other researchers [8]. For this reason a good approximation of the second order system can be achieved by setting to zero some coefficients far from the main diagonal. This is the basic idea underlying the *Simplified Volterra Filter* (SVF) structure [5] reported in Figure 5. Each branch of this structure realizes a quadratic filter whose kernel matrix has non zero coefficients only in one diagonal. By implementing N of these filters in parallel, one for each diagonal of the upper triangular kernel, we implement the complete second order Volterra filter. By cutting some branches of this realization, i.e. those representing diagonals far from the main one, we obtain the SVF structure that corresponds to a second order Volterra filter whose kernel has nonzero coefficients only in some diagonals. Due to the echo path features presented above, it is possible to realize a good approximation of the echo path system with a small number of branches, thus resulting in high computational resource savings.

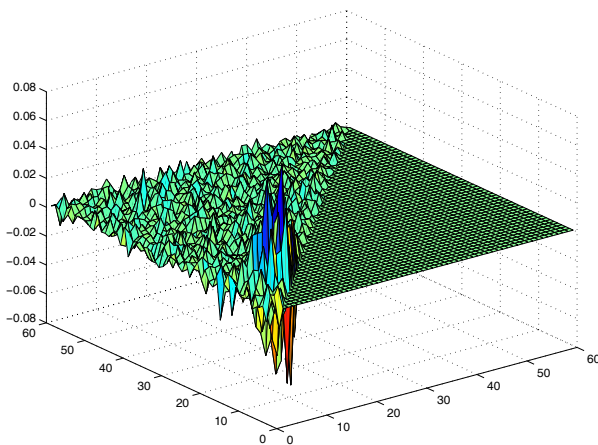

Fig. 4. Triangular second order kernel of a typical acoustic echo path.

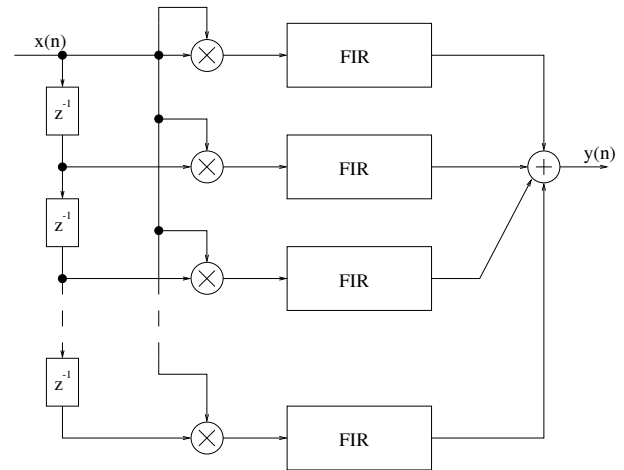

Fig. 5. Simplified Volterra filter structure.

3.3. Bilinear Filter

Just as linear IIR filters can represent many linear systems with far fewer coefficients than their FIR counterparts, recursive polynomial models can accurately represent many nonlinear systems with greater efficiency than truncated Volterra series representation. In particular, we considered the bilinear model [9], whose input-output relationship is given by:

$$y(n) = \sum_{i=0}^{N_1} h_1(i)x(n-i) + \sum_{i=1}^{N_2} h_2(i)y(n-i) + \sum_{j=0}^{N_3} \sum_{i=1}^{N_4} c_{i,j}y(n-i)x(n-j). \quad (5)$$

It is worth noting that this type of system not only has infinite memory, but also may represent very large orders of nonlinearity [9]. On the contrary, there are some problems related to the implementation of this type of filter in the adaptive version:

- The stability is not guaranteed (due to the recursive nature of this kind of structure).
- The adaptive procedure suffers from the local minima problem, due to the nonlinearity of the filter output with respect to the coefficients.

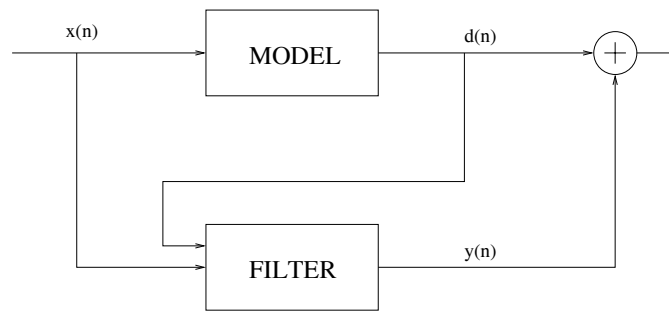

Fig. 6. Equation error adaptive bilinear filter.

For these two reasons we considered the *Equation Error Adaptive Bilinear Filter*, whose scheme is reported in Figure 6. The output of this filter can be expressed by the relation:

$$y(n) = \mathbf{h}_1^T \mathbf{x}(n) + \mathbf{h}_2^T \mathbf{d}(n) + \mathbf{d}^T(n) \mathbf{C} \mathbf{x}(n) \quad (6)$$

where the third term of the summation represents the nonlinear part of the filter. By using this structure, we overcome both problems reported above. In fact, in this way, the process of recursive estimation becomes a non-recursive estimation made on two channels. Moreover, the filter output becomes linear with respect to its coefficients. However, the estimation procedure leads to a biased estimate of the optimum solution [6], thus limiting the performances in the identification procedure.

4. Experimental Results

We tested all the structures considered in Section 3 in acoustic echo cancellation applications. For this purpose we first considered an artificial acoustic echo path model extracted from the acquisition of the response of a commercial handset receiver. In this way we tested the performances of all the filters we had considered with different level of nonlinear distortions. We used a set of sequences of coloured noise whose spectral shaping was chosen very similar to the power spectral density of the voice signal. In Figure 7 the level of echo cancellation is plotted for some of the filters we considered versus the nonlinear distortion level. The echo cancellation is expressed as OP/MSE , that is the ratio between the average echo signal power and the average residual echo signal power. Note that the maximum reduction achievable is 30 dB, because we added a random noise to the echo

signal whose average power was 30 dB below the echo itself. The ratio L/N represents the ratio between the average power of the linear part of the model and the average power of the second order part of the model. The second order Volterra filter (VOLT) behaves well for all the levels of distortion. As we can see, SVFs are the filters with higher performance, even for high level of distortion. This is particularly true of SVF20 which has 20 branches. Performances of the linear filter (LIN) decay almost linearly with the increase on the nonlinear distortion, whereas the bilinear filter (BILIN) with only 5 branches has performances close to those of the SVF5 for low levels of distortion. However, these performances degrade significantly for higher order of nonlinearity.

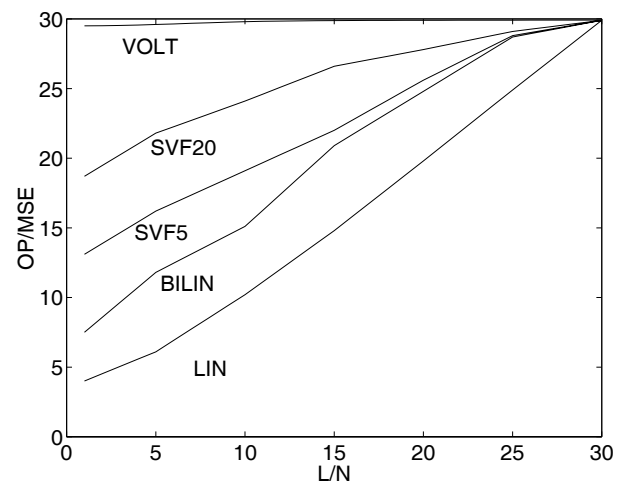

Fig. 7. Echo cancellation obtained by some significant filters, in dB, plotted versus nonlinear second order distortion in dB.

Then we acquired many echo signals generated by two commercial handset receivers and we compared the performances of different echo

cancelling filters in terms of the Echo Return Loss Enhancement defined as:

$$ERLE(n) = 10 \log_{10} \frac{E[d^2(n)]}{E[e^2(n)]}, \quad (7)$$

where $d(n)$ is the echo signal picked up by the microphone and $e(n)$ is the residual echo after cancellation. In Table 1 the results relative to different kinds of filters are reported, in term of steady state average ERLE, obtained with some speech sequences. Due to high nonlinear distortions that we noticed in the acoustic echo path (as reported in Figure 8), we noticed a significant improvement (more than 5 dB) in acoustic echo cancellation by implementing a second order Volterra filter. The memory of the second order part of the filter was chosen significantly lower than that of the linear part, without compromising the performances. The results reported in Table 1 refer to the case of 100 coefficients for the linear filter and a memory of 30 samples for the quadratic filter. However, as we can see, the complexity still remains high, and unacceptable for a real time application as AEC.

The MMD performances reported are the best we found for all the different choices of N_a and N_p , keeping fixed the memory length of the filter (in particular $N_a = 21$ and $N_p = 9$). The bad performances found are due to the presence of local minima.

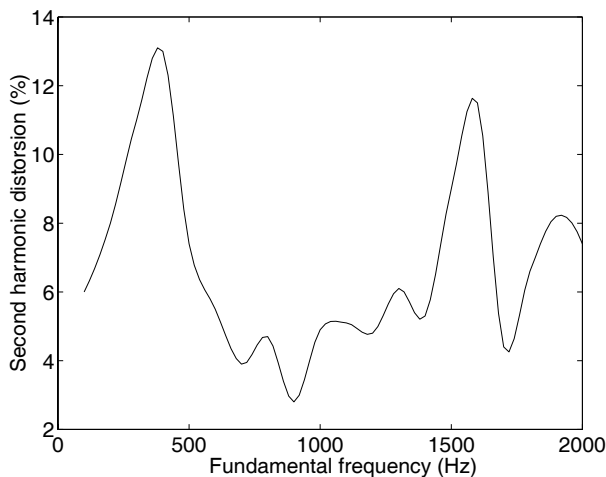

Fig. 8. Second order harmonic distortion of the echo path plotted versus fundamental frequency.

Filter	ERLE(dB)	Mult.
LINEAR	17.0	202
VOLTERRA 2	22.1	1599
MMD	17.5	456
PAR-CASCADE	17.9	528
SVF (5)	19.7	487
SVF (10)	20.8	722
SVF (15)	21.5	907
SVF (20)	21.8	1042
BILINEAR (2)	19.1	267
BILINEAR (5)	20.0	363

Table 1. Echo cancellation obtained by different filters with high level of conversation and corresponding number of multiplications per sample time.

The PAR-CASCADE performances reported refer to the results obtained by implementing 10 branches. We did not accomplish a significant gain by implementing a larger number of branches.

The SVF structures employed have a memory of 30 samples; the number of branches employed is reported in the brackets. Note that there is a significant gain over the linear structure, even with a low number of branches employed.

The BILINEAR structures have a memory of 15 samples with respect to the input signal $x(n)$. We found that the best choice is to implement a filter with low memory with respect to the reference signal $d(n)$, and higher memory with respect to the input signal $x(n)$. In particular, the results in Table 1 refer to the cases of memory equal to 2 and 5 samples, respectively, as reported in the brackets.

5. Conclusions

Often linear filters perform poorly in acoustic echo cancellation applications due to the nonlinear nature of the acoustic echo path. We analyzed the behaviour of some low complexity filters in order to find a structure able to reach performances in acoustic echo cancellation near to that of the second order Volterra filter with reduced computational resources. Some of the structures we considered performed poorly because of the presence of local minima. However, two structures satisfied our issues: the SVF structure and the equation error bilinear

structure. The former requires a number of multiplications relatively high, but obtains results close to those of Volterra filters. On the contrary, bilinear filters obtain slightly worse results, but need less computational resources.

References

- [1] BISKETT, GOUBREN, Limitations of Handsfree AEC due to Nonlinear Loudspeaker Distorsion and Enclosure Vibration Effects, *Proceedings of ASSP-95*, pp. 103–106, 1995.
- [2] A. STENGER, R. RABENSTEIN, An Acoustic Echo Canceller with Compensation of Nonlinearities, *Proceedings of Eusipco-98*, Rodes, Greece, pp. 969–972, 1998.
- [3] W. A. FRANK, An Efficient Approximation to the 2nd Order Volterra Filter, *Signal Processing* vol. 45, pp. 97–113, 1995.
- [4] T. M. PANICKER AND V. J. MATHEWS, Parallel-Cascade Realizations and Approximations of Truncated Volterra Systems, *Proc. ICASSP-96*, Atlanta, Georgia, 1996.
- [5] A. FERMO, A. CARINI, G. L. SICURANZA, Simplified Volterra filters for acoustic echo cancellation in GSM receivers, *Proc. EUSIPCO-2000*, Tampere, Finland, Sept. 2000.
- [6] V. J. MATHEWS, G. L. SICURANZA, *Polynomial Signal Processing*, J. Wiley, New York, 2000.
- [7] G. L. SICURANZA, Quadratic Filters for Signal Processing, *Proceedings of the IEEE*, Vol. 80, No. 8, August 1992, pp. 1262–1285.
- [8] A. STENGER, R. RABENSTEIN, Adaptive Volterra Filters for Nonlinear Acoustic Echo Cancellation, *Proceedings of NSIP 99*, Antalya, Turkey, June 1999, pp. 679–683.
- [9] V. J. MATHEWS, Adaptive Polynomial Filters, *IEEE Signal Processing Magazine*, 8(3), pp. 10–26, July 1991.

Received: October, 2000
Accepted: November, 2000

Contact address:

Andrea Fermo
D.E.E.I., University of Trieste
Trieste, Italy
e-mail: fermo@ipl.univ.trieste.it

Alberto Carini
Telit Mobile Terminals S.p.A.
Sgonico (Trieste)
Italy
e-mail: alberto.carini@telital.it

Giovanni L. Sicuranza
D.E.E.I., University of Trieste
Trieste, Italy
e-mail: sicuranza@univ.trieste.it

ANDREA FERMO was born in Trieste, Italy on June 17, 1974. He received the Laurea degree in electronic engineering in 1999 from the University of Trieste, Italy and he is now attending his Ph.D. studies on information engineering at the same university.

His research interests include adaptive and nonlinear filtering, image compression and motion compensation techniques.

ALBERTO CARINI was born in Trieste, Italy, on June 5, 1967. He received the Laurea degree (summa cum laude) in electronic engineering in 1994 and the "Dottorato di Ricerca" degree (Ph.D.) in information engineering in 1998, both from the University of Trieste, Italy. In 1996 and 1997, during his Ph.D. studies, he spent several months as a visiting scholar at the University of Utah, Salt Lake City, USA.

He has received the Zoldan award for the best Laurea degree in electronic engineering at the University of Trieste during the academic year 1992–93. At present, he is working as a DSP engineer with Telital S.p.A., Trieste, Italy.

His research interests include adaptive filtering, nonlinear filtering, nonlinear equalization and acoustic echo cancellation.

GIOVANNI L. SICURANZA is Professor of signal and image processing and head of the Image Processing Laboratory at the Department of Elettrotecnica Elettronica Informatica, University of Trieste (Italy), where he has given courses on analog circuits, digital circuits, and digital signal and image processing. He was also a teacher in European courses on image processing and analysis, and the organizer of the EURASIP course on "Linear and Nonlinear Filtering of Multidimensional Signals" (Trieste, Italy, 1990).

His research interests include multidimensional digital filters, polynomial filters, processing of images and image sequences, image coding, and neural networks for signal processing.

He has published a number of papers in international journals and conference proceedings.

He contributed chapters for four books and is the co-editor of the books "Multidimensional Processing of Video Signals", Kluwer Academic Publisher, 1992, and "Nonlinear Image Processing", Academic Press, 2001.

He is the co-author of the book "Polynomial Signal Processing", J. Wiley, 2000. Dr. Sicuranza has been a member of the technical committees of numerous international conferences and Chairman of the VIII European Signal Processing Conference, EUSIPCO-96 (Trieste, Italy, 1996).

He is an Associate Editor of "Multidimensional Systems and Signal Processing" and member of the editorial board of "Signal Processing" and "Display and Imaging International Edition".

Dr. Sicuranza has served as a project manager of ESPRIT and COST research projects funded by the European Commission and as a consultant to several industries.

He is currently member of the Administrative Committee of the European Association for Signal, Speech and Image Processing (EURASIP) and of the Image and MultiDimensional Signal Processing (IMDSP) Technical Committee of the IEEE Signal Processing Society. He is also the Past Chairman of the Nonlinear Signal and Image Processing (NSIP) Board.
