

SE-99-15-01

Calculating the Solar Heat Gain of Window Frames

John L. Wright, Ph.D., P.Eng.
Member ASHRAE

Alex McGowan, B.A.Sc., P.Eng.
Member ASHRAE

ABSTRACT

It is not practical to measure the solar heat gain of a window frame. It is more practical to do so by calculation. Typically, the frame solar heat gain is a small component of the total or is small in absolute terms so an approximate method is satisfactory. A simple approach for calculating the solar heat gain coefficient of any opaque window component is developed. The parameters appearing in the expression clearly identify the mechanisms of frame solar gain and indicate the ways in which it can be controlled. A particularly simple expression can be applied to any frame geometry for cases in which the solar radiation is incident normal to the window. This is especially useful because this condition is frequently used for energy rating purposes, code compliance, and design. It is shown that this expression is also valid for off-normal incidence as long as no part of the frame is shaded. An adjustment, based only on frame surface geometry, can be applied if the frame is partially shaded. Sample calculations closely reproduce the results of detailed two-dimensional numerical simulation.

INTRODUCTION

The solar heat gain of a window is primarily a function of the solar optics and heat-transfer characteristics of the glazing system (i.e., view area). The solar gain of the opaque window components (e.g., frame, sash, dividers) is generally a very small portion of the total solar gain and is usually neglected. In most cases this is a reasonable assumption (Wright 1995) but not always. Consider a commercial application where tinted glass and/or reflective solar control coatings have been used so that the solar heat gain of the glazing system is very low. If this glazing system is installed in a

dark colored frame with low thermal resistance (thermally unbroken aluminum) that occupies a large portion of the window area it is possible that the solar gain of the frame may even exceed the solar gain of the view area.

Relatively few facilities exist for measuring the solar heat gain of windows. Those available fall into two broad categories: (1) outdoor testing using solar radiation and (2) indoor testing using an artificial source of radiation at solar wavelengths. Each method entails specific technical difficulties (Harrison et al. 1996) with an associated uncertainty attached to the measured result. Consequently, test methods cannot be expected to resolve the solar gain component of window frames except in extreme cases where a large portion of the total solar gain is contributed by the frame. Even in these cases a high level of experimental uncertainty can be expected.

If the solar heat gain of a window frame is to be determined it is more practical to do so by calculation. In the majority of cases the frame solar heat gain is a small component of the total or is small in absolute terms so an approximate method is satisfactory. This study presents the development of a simple expression for calculating the solar heat gain coefficient (SHGC) of any opaque window component. Results obtained using this simplified approach are compared with the results of detailed numerical simulation.

ABSORBED SOLAR RADIATION AND INWARD-FLOWING FRACTION

Solar radiation incident on the view area of a window is either reflected, transmitted, or absorbed within one of the glazing layers. It is customarily assumed that all of the transmitted radiation is absorbed at indoor surfaces. A portion of the radiation absorbed in any one glazing layer will be redirected to either the outdoor or indoor side by means of heat

John L. Wright is an associate professor in the Department of Mechanical Engineering, University of Waterloo, Waterloo, Ontario, Canada. **Alex McGowan** is vice president of Enermodal Engineering Ltd., Kitchener, Ontario, Canada.

transfer. The solar gain consists of the energy transmitted directly to the conditioned space plus the portion of the energy absorbed in the glazing layers that makes its way to the indoor side. A solar optical calculation is used to determine the amounts transmitted and absorbed. A heat-transfer calculation is used to determine the inward-flowing fraction of the solar radiation absorbed in the glazing layers. A more detailed discussion regarding the two components of solar gain can be found in Wright (1995).

Window frames do not transmit solar radiation so the determination of frame solar heat gain requires only the consideration of the absorbed/redirected component. The calculations to determine inward-flowing fraction differ between frames and glazing systems primarily because glazing systems are analyzed using a one-dimensional (1D) model and frames using a 2D model. Nonetheless, it is useful to review the detail of the glazing-system model because the concepts and approach can be carried over to the frame analysis.

Inward-Flowing Fraction for Double-Glazed Glazing Systems

Consider the double-glazed system shown in Figure 1. An optical calculation has been completed (e.g., Edwards 1977; Wright 1998) giving the absorbed fluxes of solar energy in the conditioned space, S_1 , and at the glazing layers, S_2 and S_3 . Each glazing layer is assumed to be isothermal, and the heat-transfer analysis (e.g., Hollands and Wright 1980, 1983; Finlayson et al. 1993; Wright 1998) has provided the values of thermal resistance, R_1 , R_2 , R_3 , step-by-step through the glazing-system array. Accordingly, the heat flux between each pair of temperature nodes in the array, including heat transfer by convection and radiant exchange, can be written as:

$$q_1 = \frac{T_2 - T_1}{AR_1}, \quad (1)$$

$$q_2 = \frac{T_3 - T_2}{AR_2}, \quad (2)$$

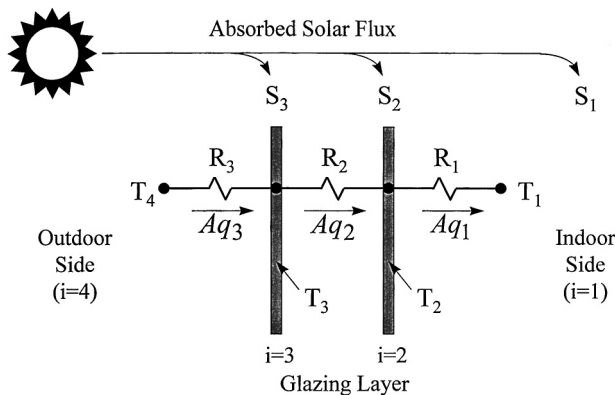

Figure 1 Resistance network for a double-pane-glazing system showing absorbed amounts of solar radiation.

$$q_3 = \frac{T_4 - T_3}{AR_3}. \quad (3)$$

Each of the resistance values corresponds to a given heat-transfer area A and carries units of, for example, K/W. The use of thermal resistance defined in this fashion makes it possible to construct resistance networks similar to simple electrical circuits and to sum the various “resistors” in parallel or in series accordingly. This approach can be found in many introductory heat-transfer textbooks (e.g., Chapter 3 of Incropera and DeWitt 1996). The glazing system is a particularly simple arrangement because the resistors are all connected in series and the heat-transfer area is constant.

Energy balances applied at the glazing layers yield

$$q_2 = q_1 - S_2 \quad (4)$$

$$q_3 = q_2 - S_3. \quad (5)$$

The goal is to solve Equations 1 through 5 for q_1 in terms of T_1 , T_4 , R_1 , R_2 , R_3 , S_2 , and S_3 .

Equations 1 and 2 can be rewritten as

$$T_2 = T_1 + q_1 AR_1 \quad (6)$$

$$T_2 = T_3 - q_2 AR_2 \quad (7)$$

Eliminating T_2 and solving for T_3 :

$$T_3 = T_1 + q_1 AR_1 + q_2 AR_2 \quad (8)$$

Equation 3 can be rearranged to give

$$T_3 = T_4 - q_3 AR_3 \quad (9)$$

Now T_3 can be eliminated from Equation 8:

$$T_4 - T_1 = A\{q_1 R_1 + q_2 R_2 + q_3 R_3\} \quad (10)$$

Equation 5 can be used to eliminate q_3 from Equation 10:

$$\begin{aligned} T_4 - T_1 &= A\{q_1 R_1 + q_2 R_2 + (q_2 - S_3) R_3\} \\ &= A\{q_1 R_1 + q_2 (R_2 + R_3) - R_3 S_3\} \end{aligned} \quad (11)$$

Similarly, Equation 4 can be used to eliminate q_2 from Equation 11:

$$\begin{aligned} T_4 - T_1 &= A\{q_1 R_1 + (q_1 - S_2)(R_2 + R_3) - R_3 S_3\} \\ &= A\{q_1 (R_1 + R_2 + R_3) - (R_2 + R_3) S_2 - R_3 S_3\} \end{aligned} \quad (12)$$

Equation 12 can be rearranged to give the result being sought:

$$q_1 = \frac{T_4 - T_1}{AR_{tot}} + N_2 S_2 + N_3 S_3, \quad (13)$$

where

$$R_{tot} = R_1 + R_2 + R_3, \quad (14)$$

$$N_2 = \frac{R_2 + R_3}{R_{tot}}, \quad (15)$$

and

$$N_3 = \frac{R_3}{R_{tot}}. \quad (16)$$

$$Q_{fr} = \frac{T_{out} - T_{in}}{R_{fr}} = U_{fr} A_{pr} (T_{out} - T_{in}), \quad (23)$$

where

$$R_{fr} = R_{out} + R_c + R_{in} \quad (24)$$

and U_{fr} is the frame U factor based on the projected area of the frame, A_{pr} (ASHRAE 1997).

It is also assumed that solar radiation is absorbed only on the outdoor surface of the frame. The location of this source of solar energy on A_s is not important because the outdoor surface is assumed isothermal. It is only necessary to know the rate at which solar radiation is absorbed. This source of absorbed solar energy is denoted $A_s S_s$ to emphasize the idea that it consists of some absorbed flux over area A_s .

The frame solar heat gain can be determined using an approach similar to the method used to examine glazing systems. The following three equations, consisting of two heat-transfer rate equations and one energy balance, are considered:

$$Q_{in} = Q_{fr} = \frac{T_s - T_{in}}{R_c + R_{in}}, \quad (25)$$

$$Q_{out} = \frac{T_{out} - T_s}{R_{out}}, \quad (26)$$

$$Q_{out} = Q_{fr} - A_s S_s = Q_{in} - A_s S_s. \quad (27)$$

Equations 25 and 26 can be combined to eliminate T_s giving

$$T_{out} - T_{in} = Q_{in}(R_c + R_{in}) + Q_{out}R_{out} \quad (28)$$

Now Equation 27 can be used to eliminate Q_{out} :

$$T_{out} - T_{in} = Q_{in}(R_c + R_{in}) + (Q_{in} - A_s S_s)R_{out} \quad (29)$$

Rearranging gives

$$Q_{in} = \frac{T_{out} - T_{in}}{R_{fr}} + \frac{R_{out}}{R_{fr}} A_s S_s \quad (30)$$

It can be seen that the heat transfer from the frame to the indoor space consists of two components: (1) the heat transfer driven by the indoor/outdoor temperature difference, and (2) the inward-flowing fraction of the solar energy absorbed on the outdoor surface of the frame. This inward-flowing fraction is

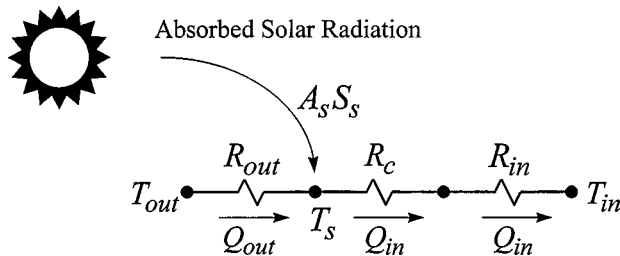

Figure 3 Resistance network for a window frame showing absorbed solar radiation.

$$N_{fr} = \frac{R_{out}}{R_{fr}} \quad (31)$$

Noting that (see Equation 23),

$$R_{fr} = \frac{1}{U_{fr} A_{pr}} \quad (32)$$

and expressing R_{out} in terms of the outdoor film coefficient, h_o ,

$$R_{out} = \frac{1}{h_o A_s}, \quad (33)$$

the inward-flowing fraction of solar radiation absorbed on the outdoor surface of the window frame can now be written as

$$N_{fr} = \frac{U_{fr} A_{pr}}{h_o A_s} \quad (34)$$

Knowing the incident solar flux, I_s , and the solar absorptivity of the frame, α_s , the amount of solar energy absorbed on the frame can be determined and Equation 34 can be used to calculate the resulting solar gain. Accordingly it is possible to determine a solar heat gain coefficient for the frame, $SHGC_{fr}$.

The definition of $SHGC_{fr}$ must be clearly understood. A solar heat gain coefficient is simply the fraction of solar radiation incident on the building envelope that makes its way to the conditioned space as solar gain. The total gain through the frame to the conditioned space can be written as

$$Q_{in} = U_{fr} A_{pr} (T_{out} - T_{in}) + SHGC_{fr} A_{pr} I_s. \quad (35)$$

Here it is clear that I_s is the solar flux incident on A_{pr} and must be based on that same area.

Equations 30, 34 and 35 can be combined to give

$$SHGC_{fr} = N_{fr} \frac{A_s S_s}{A_{pr} I_s}. \quad (36)$$

Recall that the numerator of the fraction shown in Equation 36 is a lumped quantity meant to represent the rate at which solar energy is absorbed at the frame surface without specific knowledge about the area over which the energy is absorbed or the way in which the solar flux is distributed. The denominator is the rate at which solar radiation would be incident on the projected frame area if the window were not present. Specific information must be available about the shape of the window frame and the directional nature of the incident solar radiation before Equation 36 can be evaluated.

Solar Radiation Incident Perpendicular to the Window

The simplest situation to consider is the case where beam solar radiation is incident perpendicular to the plane of the window. It can be seen that the fraction appearing in Equation 36 reduces to the solar absorptivity of the frame, α_s , because

$$A_s S_s = \alpha_s A_{pr} I_s \quad (37)$$

Combining Equation 37 with Equations 34 and 36, $SHGC_{fr}$ can now be calculated from known quantities:

$$SHGC_{fr} = \alpha_s \frac{U_{fr} A_{pr}}{h_o A_s} \quad (38)$$

Flush Outdoor Frame Surface

It is also possible to calculate $SHGC_{fr}$ for a frame if its exposed outdoor surface is flush with the outdoor side of the glazing system. A simple example of this type of design is shown in Figure 4.

If the outdoor surface of the frame is flat and does not protrude appreciably beyond the outdoor surface of the glass, it can then be seen that

$$S_s = \alpha_s I_s \quad (39)$$

and that

$$A_s = A_{pr} \quad (40)$$

Using Equations 34 and 36 the solar heat gain coefficient for a flush-surface frame is

$$SHGC_{fr} = \alpha_s \frac{U_{fr}}{h_o} \quad (41)$$

Off-Normal Solar Radiation

Consider the frame section shown in Figure 2. It can be expected that the solar gain through the frame will change as the location of the sun changes. If the solar radiation is normal to the window, Equation 37 applies and $SHGC_{fr}$ is given by Equation 38. If the sun were still directly in front of the window but higher in the sky the $A_s S_s$ product would increase because more solar radiation would be intercepted and I_s would decrease because A_{pr} would intercept less of the off-normal solar radiation. The net result, as indicated by Equation 36, is that $SHGC_{fr}$ will increase appreciably. However, it is wrong to conclude that the window solar heat gain will always be sensitive to this effect. It must be remembered that there is a head section for each sill and that if the sun is oriented such that one section receives a large amount of solar radiation, the other section will receive less.

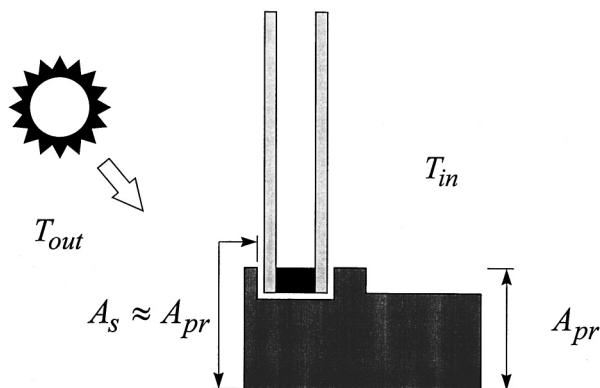

Figure 4 Cross section of a flush window frame.

The influence of incidence angle can be explored using the simple frame profile shown in Figure 5. The outdoor surface of the frame is rectangular with horizontal dimension a and vertical dimension b . A constant beam solar flux I_b (measured normal to the beam) is incident at an angle θ above the horizontal. Given this geometry the following relations hold for the sill:

$$\frac{A_s S_s}{A_{pr} I_s} = \frac{\alpha_s (b I_b \cos \theta + a I_b \sin \theta)}{b I_b \cos \theta} \quad (42)$$

or, using this result with Equations 34 and 36 to determine a solar heat gain coefficient for the sill,

$$SHGC_{sill} = \alpha_s \frac{U_{fr} A_{pr}}{h_o A_s} \left(1 + \frac{a}{b} \tan \theta \right) \quad (43)$$

A similar analysis can be applied at the head section with self-shading considered. The result is

$$SHGC_{head} = \alpha_s \frac{U_{fr} A_{pr}}{h_o A_s} \quad (44)$$

Assuming that A_{pr} is equal at the head section and the sill, the two solar heat gain coefficients can be averaged, giving a combined solar heat gain coefficient for the frame:

$$SHGC_{fr} = \alpha_s \frac{U_{fr} A_{pr}}{h_o A_s} \left(1 + \frac{a}{2b} \tan \theta \right) \quad (45)$$

Finally, substituting,

$$\frac{a}{b} = \frac{A_s - A_{pr}}{A_{pr}} \quad (46)$$

$SHGC_{fr}$ becomes

$$SHGC_{fr} = \alpha_s \frac{U_{fr} A_{pr}}{h_o A_s} \left(1 + \frac{1}{2} \frac{A_s - A_{pr}}{A_{pr}} \tan \theta \right) \quad (47)$$

The quantity enclosed by parentheses can be seen as a factor, say F_{on} , that can modify the result of Equation 38 to convert $SHGC_{fr}$ from a value that applies to solar radiation perpendicular to the window to a value that can be applied at off-

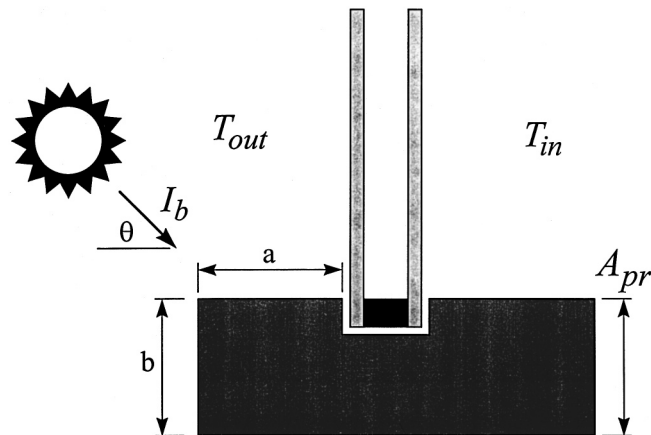

Figure 5 Rectangular frame with off-normal beam solar radiation.

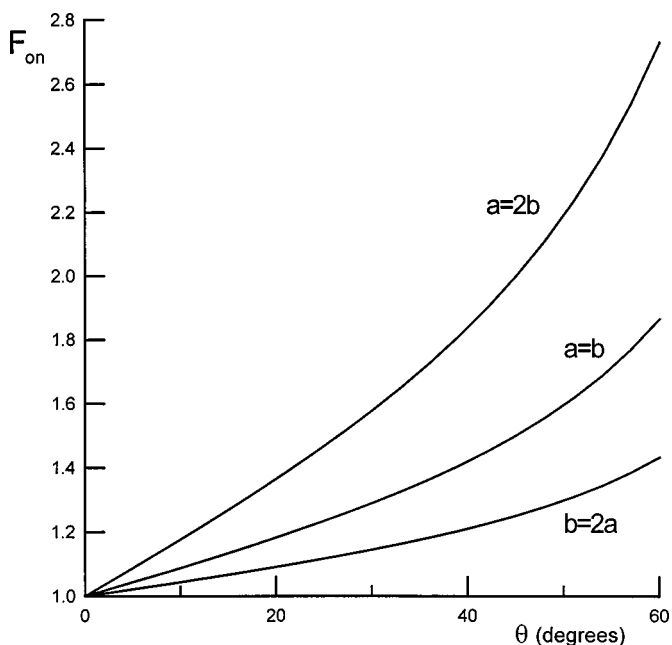

Figure 6 F_{on} versus θ —rectangular surface frame.

normal angles of incidence. Note that F_{on} is equal to unity at $\theta=0^\circ$ or if $A_s - A_{pr}=0$. If, for example, $A_s=2A_{pr}$ and $\theta=45^\circ$, then this factor is equal to 1.5. Figure 6 shows F_{on} plotted as a function of θ for various values of a/b .

Consider a second frame geometry where the outdoor surface consists of a single slope at an angle β as shown in Figure 7. Initially the situation where $\theta < \beta$ is examined (i.e., the frame does not shade the glass or itself). At the sill,

$$\frac{A_s S_s}{A_{pr} I_s} = \frac{\alpha_s (A_{pr} / \sin \beta) I_b \sin(\beta + \theta)}{A_{pr} I_b \cos \theta} \quad (48)$$

or

$$\text{SHGC}_{\text{sill}} = \alpha_s \frac{U_{fr} A_{pr}}{h_o A_s} \left(\frac{\sin(\beta + \theta)}{\sin \beta \cos \theta} \right) \quad (49)$$

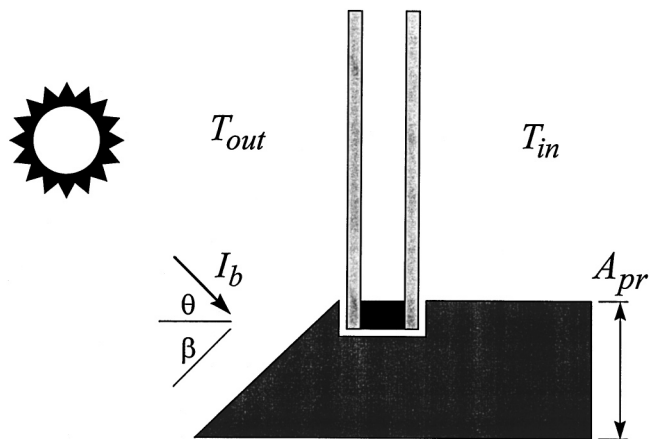

Figure 7 Sloped frame surface with off-normal beam solar radiation.

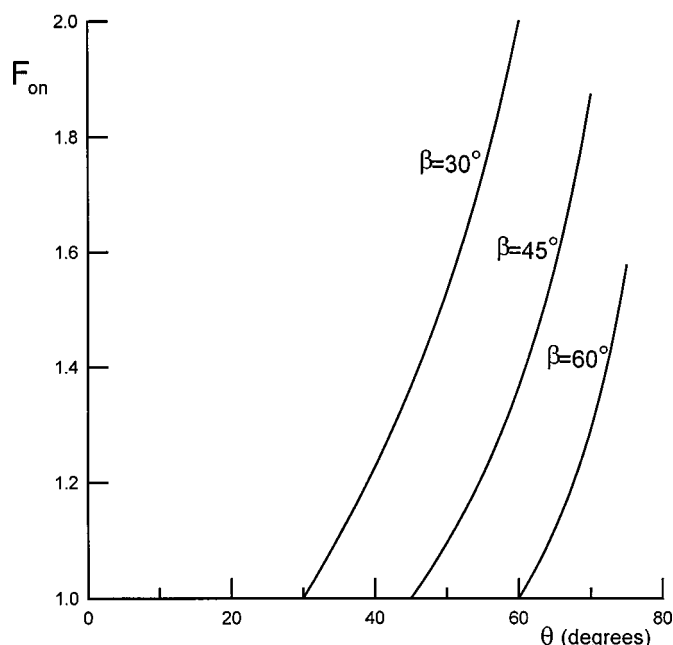

Figure 8 F_{on} versus θ —sloped surface frame.

Similarly, at the head section,

$$\text{SHGC}_{\text{head}} = \alpha_s \frac{U_{fr} A_{pr}}{h_o A_s} \left(\frac{\sin(\beta - \theta)}{\sin \beta \cos \theta} \right) \quad (50)$$

Averaging Equations 49 and 50:

$$\text{SHGC}_{fr} = \alpha_s \frac{U_{fr} A_{pr}}{h_o A_s} \left(\frac{\sin(\beta + \theta) + \sin(\beta - \theta)}{2 \sin \beta \cos \theta} \right) \quad (51)$$

This is a very interesting result because the quantity shown in parentheses is equal to unity and the solar heat gain coefficient of the frame is again given by Equation 38.

If θ exceeds β Equation 51 (i.e., Equation 38) must be replaced by

$$\text{SHGC}_{fr} = \alpha_s \frac{U_{fr} A_{pr}}{h_o A_s} \left(\frac{1}{2} + \frac{1}{2} \tan \theta \right) \quad (52)$$

As θ is increased beyond β the absorbed solar radiation at the head section no longer decreases (having reached zero) with the result that Equation 52 predicts a sharply higher SHGC_{fr} . Figure 8 shows F_{on} , the quantity in parentheses in Equation 52, plotted as a function of θ for various frames with outdoor surfaces sloped at angle β .

Next, consider the frame geometry shown in Figure 9. The outdoor surface consists of a sloped section plus a vertical section. Following the same procedure used to obtain Equations 47 and 51 it can be shown that SHGC_{fr} is again given by Equation 38 as long as θ does not exceed β . This is equivalent to saying that Equation 38 can be applied, even if the incident solar radiation is off-normal, as long as none of the frame is shaded.

Going one step further, the solar gain can be summed over any number of sloped frame surfaces. This more general geometry is shown in Figure 10. The outdoor surface of the

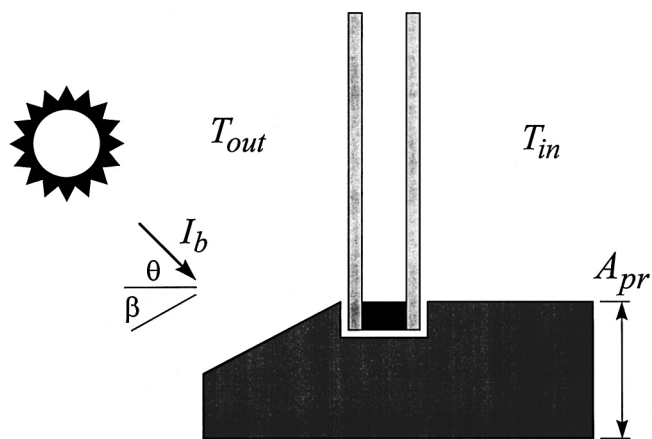

Figure 9 Beveled frame surface with off-normal beam solar radiation.

frame consists of n flat surfaces each of height a_i and sloped at an angle β_i from the horizontal. At the sill,

$$\frac{A_s S_s}{A_{pr} I_s} = \frac{\alpha_s \sum_{i=1}^n (a_i / \sin \beta_i) I_b \sin(\beta_i + \theta)}{A_{pr} I_b \cos \theta} \quad (53)$$

or

$$\frac{A_s S_s}{A_{pr} I_s} = \frac{\alpha_s}{A_{pr}} \sum_{i=1}^n \frac{a_i \sin(\beta_i + \theta)}{\sin \beta_i \cos \theta}, \quad (54)$$

and at the head section,

$$\frac{A_s S_s}{A_{pr} I_s} = \frac{\alpha_s}{A_{pr}} \sum_{i=1}^n \frac{a_i \sin(\beta_i - \theta)}{\sin \beta_i \cos \theta}. \quad (55)$$

Averaging these results and substituting into Equations 34 and 36,

$$SHGC_{fr} = \frac{U_{fr} A_{pr}}{h_o A_s} \frac{\alpha_s}{A_{pr}} \sum_{i=1}^n a_i \frac{\sin(\beta_i + \theta) + \sin(\beta_i - \theta)}{2 \sin \beta_i \cos \theta}. \quad (56)$$

Recalling that the ratio of trigonometric quantities included in the summation is equal to unity and noting also that

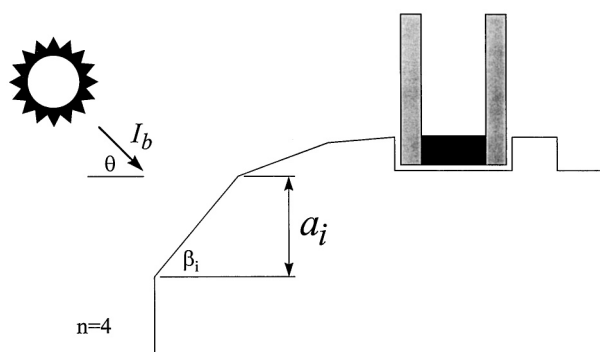

Figure 10 Cross section of multisurface frame.

$$\sum_{i=1}^n a_i = A_{pr}, \quad (57)$$

Equation 56 reduces to Equation 38. Again, the only restriction in applying Equation 38 to off-normal solar radiation is that none of the outdoor frame surface can be shaded.

Finally, the outdoor frame surface can be treated as an infinite number of infinitesimal surfaces. This corresponds to a frame of any arbitrary shape. When the integration is performed to sum the solar gain, the resulting expression again reduces to Equation 38—as long as none of the frame is shaded.

If θ becomes large enough that some of the frame is shaded, it is still possible to develop an expression for $SHGC_{fr}$ in the same way that Equations 47 and 52 were developed. However, it should be noted that any increase in $SHGC_{fr}$ at higher solar incidence angles will be offset to some degree, and possibly more than offset, by the corresponding shadow cast by the frame on the view area of the window. Any extra effort spent in calculating the solar heat gain of the frame at high incidence angles will be wasted unless a similar effort is devoted to determining the shaded area of the glazing system.

COMPARISON WITH DETAILED CALCULATIONS

In order to verify the model just presented, $SHGC_{fr}$ values were calculated using a detailed 2D numerical analysis. Results from this analysis pertain to three frame types (aluminum, thermally broken aluminum, and wood) with solar radiation incident at one of two angles ($\theta=0^\circ$ and $\theta=45^\circ$). The effect of changing the outdoor heat-transfer coefficient h_o was also explored.

Cross sections of the models used to represent the frames are shown in Figures 11 and 12. The two aluminum

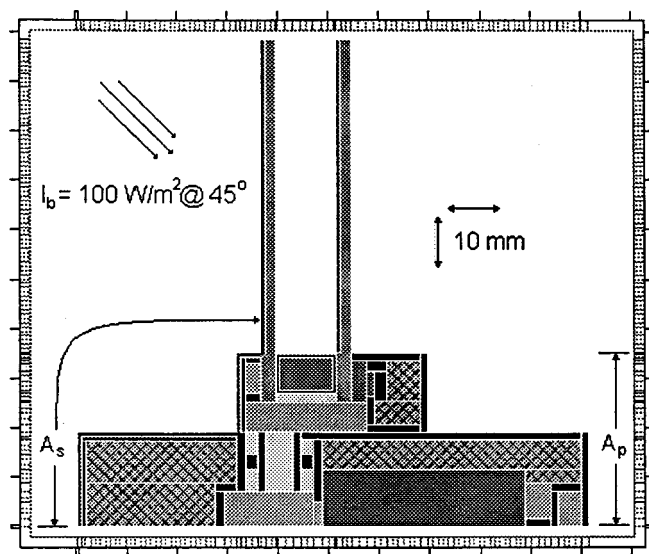

Figure 11 Aluminum and thermally broken aluminum frame models.

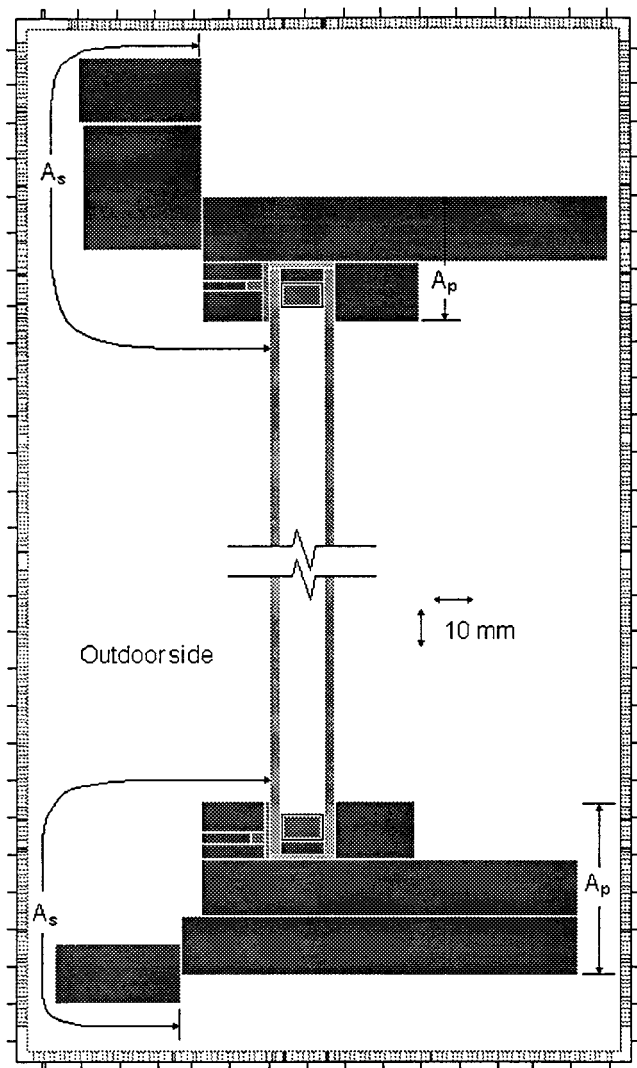

Figure 12 Wood frame model.

frames are identical except that the thermal break material was replaced by aluminum to create the thermally unbroken (solid aluminum) frame. Both the head and sill sections of the wood frame were considered. In each case the glazing unit consists of two sheets of uncoated clear glass with a conventional aluminum spacer assembly.

The numerical simulation was undertaken using software that performs a 2D finite-volume conduction calculation. This software, called FRAME (EEL 1995), is designed specifically for the heat-transfer analysis of window frames. Simulations were used in a two-step procedure to determine $SHGC_{fr}$. First, one simulation was completed with zero solar radiation. The rate of heat transfer between the indoor frame surface and the conditioned space (driven by the indoor/outdoor temperature difference) was noted. Then, while keeping everything else unchanged, the simulation was rerun with a fixed amount of solar radiation present. The effect of solar radiation absorbed in the glass was included. The rate of heat transfer at the indoor surface of the frame was noted

again. The difference between these two rates of heat transfer was taken to be frame solar gain, and $SHGC_{fr}$ was determined as the ratio of this rate of solar gain to the rate at which the solar radiation (a flux of 100 W/m^2 normal to the beam) would have been incident on A_p .

The effect of absorbed solar radiation was included in the numerical analysis by replacing a 1-mm (0.039-in.)-thick layer of the outdoor frame surface with material of equal size and conductivity but also with an energy source matching the product of incident solar flux and solar absorptivity.

Table 1 presents a comparison between $SHGC_{fr}$ values predicted by Equation 38 and simulation results for solar radiation normal to the plane of the window. Equation 38 very closely matched the $SHGC_{fr}$ values generated by FRAME for both aluminum frames. The discrepancy was 5% at most. The corresponding discrepancy for the wood sill was significantly larger but the solar heat gain of this type of frame is relatively small. The absolute difference in $SHGC_{fr}$ between Equation 38 and the FRAME calculation was small. It was 0.011 or less in all cases (i.e., less than 1.1% of the incident solar radiation). This corresponds to a much smaller uncertainty when the entire window is considered.

A similar comparison is presented in Table 2 for solar radiation incident at $\theta=45^\circ$. These data apply to the sill sections of the two aluminum frames—the only frames with an appreciable solar gain ($SHGC_{fr} \approx 0.1$ at $\theta=0^\circ$). The hand calculation was undertaken using Equation 43. In this case the discrepancy between two methods of determining $SHGC_{fr}$ was 14% at most and absolute differences were approximately 0.025. This level of agreement is good in light of the fact that $SHGC_{fr}$ more than doubled with the change from $\theta=0$ to $\theta=45^\circ$. It is certain that a much larger error has been overlooked by ignoring the shadow cast by the window frame.

TABLE 1
Comparison of $SHGC_{fr}$ Results, $\theta=0^\circ$ ^a

	Aluminum (thermally unbroken)	Aluminum (thermally broken)	Wood (sill)	Wood (head)
α_s	0.7	0.7	0.7	0.7
$h_o (\text{W/m}^2 \cdot \text{K})$	34.4	34.4	34.4	34.4
$U_{fr} (\text{W/m}^2 \cdot \text{K})$	13.04	10.11	2.39	2.88
A_{pr}/A_s	0.49	0.49	0.32	0.22
$SHGC_{fr}$ Equation 38	0.130	0.101	0.016	0.013
$SHGC_{fr}$ FRAME simulation	0.124	0.097	0.024	0.024
% difference	5	4	33	47
Difference	0.006	0.004	0.008	0.011

^a $T_{in} = 21^\circ\text{C}$, $T_{out} = -18^\circ\text{C}$, h_o is fixed, natural convection on indoor side.

TABLE 2
Comparison of SHGC_{fr} Results, $\theta=45^\circ$ ^a

	Aluminum (thermally unbroken)	Aluminum (thermally broken)
α_s	0.7	0.7
h_o (W/m ² ·K)	34.4	34.4
U_{fr} (W/m ² ·K)	13.04	10.11
A_{pr}/A_s	0.49	0.49
SHGC _{fr} Equation 43	0.265	0.206
SHGC _{fr} FRAME simulation	0.238	0.181
% difference	11	14
Difference	0.027	0.025

^a $T_{in}=21^\circ\text{C}$, $T_{out}=-18^\circ\text{C}$, h_o is fixed, natural convection on indoor side.

A third set of results is presented in Table 3 to illustrate the effect of changing the outdoor heat-transfer coefficient h_o . These results pertain to solar radiation incident normal to a window with a solid aluminum frame. Even though SHGC_{fr} is strongly influenced by h_o the agreement between the two sets of results is very good. It is clear that the functional dependence of Equation 38 on h_o is correct.

DISCUSSION

The analysis and results presented here lead to several interesting points for discussion. The most valuable part of the analysis is the development of Equation 38. This simple expression gives a clear indication of how frame solar heat gain is affected by several key parameters. Solar gain increases directly with the solar absorptivity of the outdoor frame surface. Solar gain decreases as the outdoor film coefficient increases (e.g., a stronger wind) or as the U factor

TABLE 3
**Comparison of SHGC_{fr} Results as a Function of h_o
for the Solid Aluminum Frame^a**

h_o (W/m ² ·K)	34.4	20.0	16.0
U_{fr} (W/m ² ·K)	13.04	11.52	10.79
SHGC _{fr} Equation 38	0.130	0.198	0.231
SHGC _{fr} FRAME simulation	0.124	0.184	0.213
% difference	5	8	9
Difference	0.006	0.014	0.018

^a $T_{in}=21^\circ\text{C}$, $T_{out}=-18^\circ\text{C}$, $\alpha_s=0.7$, $A_{pr}/A_s=0.49$; natural convection on indoor side.

decreases (i.e., a more highly insulated frame). SHGC_{fr} will also decrease as the projected-to-surface area ratio decreases. In other words, if the projected area is held constant a larger surface area will result in a smaller solar gain because the solar energy absorbed at the outdoor frame surface can more readily escape to the outdoor environment. These general observations apply equally well to situations with normal or off-normal solar radiation because Equation 38 can be modified with an off-normal factor that is a function of only frame surface geometry.

In the development of Equation 38 it has been assumed that there is no net heat transfer between the frame and the glazing unit or between the frame and the wall and that the outdoor frame surface is isothermal. The close agreement with the results of detailed calculations (see the bottom line of Tables 1 and 2) indicates that these assumptions present little difficulty.

The first assumption is reasonable because good design practice will minimize heat transfer between components by aligning, as closely as possible, the thermal resistance of one component with that of the next. For example, the glazing unit will meet a thermally broken aluminum frame very close to the thermal break. Even though local areas of heat transfer may exist between the glazing unit and frame, this alignment will minimize the net heat transfer taking place.

No conclusions can be drawn regarding the assumption of having no net heat transfer at the frame/wall interface because this surface was also treated as adiabatic in the detailed calculation. Nonetheless, this is a reasonable assumption because of the same argument regarding the alignment of thermal resistance presented earlier and because the space between the frame and wall is typically filled with insulation or insulated at the very least by an air cavity.

Reasons can also be presented to justify the assumption of an isothermal outdoor frame surface. A frame with high thermal resistance is less likely to have an isothermal surface but it will also have a very low solar gain, allowing for a much less sophisticated prediction of SHGC_{fr}. The outdoor surface of any type of aluminum frame, or aluminum clad frame, can be expected to be isothermal because of the high conductivity of the metal. This is fortunate because it is more important to predict accurately the relatively high solar gain associated with highly conductive frames.

Equation 38 can be used to gain a perspective on the portion of solar gain that is provided by the frame of a residential window. Consider the sill of a light-colored wood frame with a solar absorptivity of 0.2. Using the data listed in Table 1, Equation 38 gives SHGC_{fr}=0.0044. In addition, assume the frame occupies 20% of the projected window area. An error of only 0.0009 would arise in estimating the solar heat gain coefficient of the window if the solar gain through the frame were ignored. Even if the solar absorptivity were increased substantially this error would remain below 0.005. Clearly, it is only important to account for the solar gain of dark-colored window frames with low thermal

resistance. The relative importance of frame solar gain will be greater in cases where solar control glazing units are being used and/or where the frame area is large.

It is common to rate or rank windows on the assumption that solar radiation is incident normal to the window. This is a situation where it is always valid to apply Equation 38 and a significant amount of effort in computer simulation can be avoided by using Equation 38. Data tabulated in the fenestration chapter of the 1997 *ASHRAE Handbook of Fundamentals* (ASHRAE 1997) were calculated using Equation 38. A window energy rating scheme developed in Canada (CSA 1993) uses an expression similar to Equation 38, based on the work of Carpenter and Baker (1992), but does not provide the possibility of accounting for solar absorptivity or the shape of the frame profile.

Finally, it is interesting to note that Equation 38 can also be used in situations where the incident solar radiation is off-normal or diffuse. The possibility of developing off-normal correction factors for any given frame profile has been demonstrated. This approach will be useful for assessing more realistic situations or might be applied to the hour-by-hour analysis of window energy performance but it must be recognized that it is equally important to account for the shading of the view area by the projecting sections of the frame. Going one step further, it is also important to consider solar radiation reflected from the frame to itself or to the view area of the window.

CONCLUSIONS

A simple expression, Equation 38, has been developed that can be used to estimate the solar heat gain coefficient of a window frame. The parameters appearing in the expression clearly identify the mechanisms of frame solar gain and indicate the ways in which it can be controlled. Equation 38 can be applied to any frame geometry for cases in which the solar radiation is incident normal to the window. This is especially useful because this condition is frequently used for energy rating purposes. Calculated $SHGC_{fr}$ values can also be used for code compliance and design.

Equation 38 can also be applied to flush-surface commercial frames regardless of the angular distribution of the incident solar radiation. This is useful because this is the type of application where the frame solar heat gain may be large enough to make a significant contribution to the solar gain of the window.

In addition, it has been shown that Equation 38 applies when off-normal solar radiation is present as long as no part of the frame is shaded. Simple expressions accounting for off-normal incidence can be developed for specific frame geometries in situations where portions of the frame are shaded.

The results of Equation 38 have been compared to more detailed numerical simulation results. Close agreement was found between $SHGC_{fr}$ values calculated for solid aluminum, thermally broken aluminum, and wood frames. This set spans

the entire range of frame designs for which solar gain is of importance. In the case of solar radiation that is incident normal to the window, the discrepancies between values of $SHGC_{fr}$ calculated by the two methods were 0.011 at most. Similar calculations pertaining to solid and thermally broken aluminum sills, with solar radiation 45° off-normal, produced discrepancies in $SHGC_{fr}$ values of approximately 0.025. These comparisons indicate that the simpler hand calculation will introduce little error into the calculation of solar gain for the entire window and that it can be used as a quick and reliable rating tool for the comparison of alternate window frame designs.

ACKNOWLEDGEMENTS

This research was supported by the Natural Sciences and Engineering Research Council of Canada and Natural Resources Canada.

REFERENCES

- ASHRAE. 1997. *ASHRAE handbook of fundamentals*. Atlanta: American Society of Heating, Refrigerating and Air-Conditioning Engineers.
- Carpenter, S.C. and J.A. Baker. 1992. Determination of total window solar heat gain coefficient. *ASHRAE Transactions* 98(1).
- CSA. 1993. Energy performance evaluation of windows and sliding glass doors, CSA A440.2-93. Rexdale, Ontario, Canada: Canadian Standards Association.
- Edwards, D.K. 1977. Solar absorption by each element in an absorber-coverglass array. Technical Note, *Solar Energy* 19: 401–402.
- EEL. 1990. Development of a procedure for calculating total window U -value and SHGC. Report prepared by Enermodal Engineering Ltd. for Energy, Mines and Resources Canada.
- EEL. 1995. FRAMEplus toolkit: A comprehensive tool for modeling heat transfer in windows, doors, walls and other building components. Waterloo, Canada: Enermodal Engineering Ltd.
- Finlayson, E.U., D.K. Arasteh, C. Huizenga, M.D. Rubin, and M.S. Reilly. 1993. WINDOW 4.0: Documentation of calculation procedures. Berkeley, CA: Energy and Environment Division, Lawrence Berkeley Laboratory.
- Harrison, S.J., S.J. van Wonderen, J.L. Wright, and R. McCluney. 1996. Evaluation of solar heat gain test methods. ASHRAE Research Project 713-RP, final report.
- Hollands, K.G.T. and J.L. Wright. 1980. Theory and experiment on heat loss coefficients for plastic covers. Proceedings of the American Section of the International Solar Energy Society, Phoenix, pp. 441–445.

Hollands, K.G.T. and J.L. Wright. 1983. Heat loss coefficients and effective $\alpha\tau$ products for flat-plate collectors with diathermanous covers. *Solar Energy* 30(3): 211–216.

Incropera, F.P. and D.P. DeWitt. 1996. *Fundamentals of heat*

and mass transfer, 4th ed. New York: Wiley.

Wright, J.L. 1995. Summary and comparison of methods to calculate solar heat gain. *ASHRAE Transactions* 101(1).

Wright, J.L. 1998. Calculating centre-glass performance indices of windows. *ASHRAE Transactions* 104(1).