

Sustainable Conflict Resolution: Modelling, Analysis, and Strategic Insights

by

Yasser Talal M. Matbouli

A thesis
presented to the University of Waterloo
in fulfillment of the
thesis requirement for the degree of
Doctor of Philosophy
in
Systems Design Engineering

Waterloo, Ontario, Canada, 2015

© Yasser Talal M. Matbouli 2015

I hereby declare that I am the sole author of this thesis. This is a true copy of the thesis, including any required final revisions, as accepted by my examiners.

I understand that my thesis may be made electronically available to the public.

Abstract

New methodological contributions for modelling and analyzing conflicts evolving over time are developed to provide strategic insights into the sustainability of equilibria. More specifically, key characteristics of evolving conflicts are identified in order to recognize a long-term conflict. A unique procedure for assessing robustness of equilibria is introduced to measure the possibility of deviation from these potential resolutions. By considering partial achievement of an option or course of action, attempts for a decision maker to improve an equilibrium situation can be formally taken into account. As a consequence of these advancements, certain challenges found in an ongoing Canadian energy conflict can be formally investigated, better understood, and eventually resolved.

There have been many successes in the modelling and analysis of strategic conflicts using the Graph Model for Conflict Resolution. But, as illustrated by the re-occurring Great Canadian Hydroelectric Power conflict, many important obstacles remain. This conflict, between the Canadian province of Newfoundland and Labrador (NL) and the province of Québec (QC), continued for over half a century, passing through several distinct stages and raising questions that are difficult to answer using the standard graph model approach. These questions are addressed in this thesis, and the new models and techniques developed are then demonstrated using the NL-QC conflict.

A framework for conflict characterization is suggested to help analysts understand the different stages of a conflict that evolves over time. Particularly problematic are instances when a conflict reaches an equilibrium, maintains it for some time, and then re-starts and shifts to another equilibrium. Traditional conflict resolution models, which analyze only a single round of a conflict during a specific period of time, cannot explain such observations. The conflict characterization is specifically designed to provide input parameters for models of conflicts that evolve over time. A new representation, the enhanced preference graph

model, includes decision makers' preferences, allowing for an expeditious and intuitive interpretation of some stability questions.

One major issue is the sustainability of equilibrium. In a conflict that continues for half a century, it is possible for an equilibrium to be reached, maintained for a few decades, but then to fall apart. Can the resolution of strategic conflicts be made sustainable? The concept of Level of Freedom is introduced to provide a measure of equilibrium robustness that facilitates the ranking of equilibria based on their relative robustness and offers insight into this form of long-term stability.

In a graph model, a decision maker's strategy is a selection of his or her options. Hence, an option is either taken or not selected within a given state. To make a graph model easier to link to reality, a modelling structure is proposed that allows binary (two-level) options to be replaced by options with more than two levels. This new structure facilitates the representation of preference in the modelling stage and the understanding of conflict evolution within the analysis stage. Combined with concepts relating to the robustness of equilibria, the utilization of multi-level options makes a graph model more expressive of reality and easier to understand.

Acknowledgements

I would like to express my sincere appreciation to everyone who inspired me during the creation of this thesis, especially my supervisors, Prof. Keith W. Hipel, from the University of Waterloo, and Prof. D. Marc Kilgour, from Wilfrid Laurier University.

During my PhD journey, I have been blessed with some of the best guidance and mentoring. Throughout my PhD studies, Prof. Hipel and Prof. Kilgour have always been caring, kind, positive, inspiring, and motivational. Prof. Hipel and Kilgour make a great supervisory team.

My supervisors always welcomed new ideas and encouraged me to experiment with them. Then, we would have discussions about their viability and applicability. I have had many enriching discussions and constructive comments.

My supervisors taught me how to carry out meaningful research and subsequently publish my work in journals and conference proceedings. I was taught to be positive and critical in reviewing others work. I have had the chance to do peer review for articles submitted to journals and conferences that my supervisors organized and edited.

My PhD journey has tremendously contributed to my academic attitude and research qualities. I am forever grateful for their sincere guidance.

I would also like to thank my soulmate, Hadeel Kinsarah, who has been a great companion for me during my graduate studies, and also a wonderful and loving mother to our two children, Mariah and Talal. Hadeel has made an exceptional effort to reach a balance among her studies, motherhood and friendship while providing continuous support. Hadeel has always been of great emotional support during times of stress and a source of inspiration.

I would also like to thank my PhD committee members, Prof. Liping Fang, from Ryerson University, Prof. Carl Haas, from the University of Waterloo, and Prof. Andrea Scott, from the University of Waterloo. Their constructive comments have significantly impacted my research methodology and philosophical discussions. I also thank Prof. Sabine Köszegi, my External Examiner from the Vienna University of Technology, for her time and dedicated work in examining my thesis by providing positive comments, and also coming all the way from Vienna to attend my defense.

I acknowledge that the comments and the constructive criticisms from the anonymous reviewers of different journals and conference committees, including Group Decision and Negotiations Annual Conference, IEEE Systems, Man, and Cybernetics Annual Conference, and Energy Strategic Reviews Journal, have helped me in greatly improving my work.

I would like to thank Jonathan Morgan and Allen Yu, from the Geospatial Center at the University of Waterloo, for their valuable assistance in preparing the map showing the Churchill Falls location and the provinces of Newfoundland and Labrador, and Québec.

I would like to extend my gratitude to Jane Russwurm, from the Writing Centre at the University of Waterloo, and Conrad Hipel, for editing and proofreading early versions of my dissertation.

I would also like to thank my colleagues in the Conflict Analysis Group within the Department of Systems Design Engineering, for their insightful discussions and valuable comments, especially, Yasir Al-jefri and Dr. M. Abul Bashar.

Finally, I would like to thank King Abdulaziz University and the Saudi Government, for providing me with generous financial support throughout my studies. I also thank the Saudi Cultural Bureau in Ottawa for managing my scholarship. I also thank the University of Waterloo and the Canadian public, for providing such a precious learning opportunity

and a welcoming environment for my family and me.

Dedication

To my mother, Fatima Salem Sairafi, and my father, Talal Mohammad Saeed Matbouli, for their contineous support and passion which inspired my life.

Table of Contents

Abstract	iii
List of Tables	xv
List of Figures	xvii
Glossary of Terms	xix
1 Introduction	1
1.1 Overview	1
1.2 Motivation	2
1.3 Objectives	3
1.4 Organization of the Thesis	3
1.4.1 Thesis Integration	5
2 Literature Review	7
2.1 Conflict Theory	7

2.2	Conflict Resolution Models	9
2.3	The Graph Model for Conflict Resolution (GMCR)	10
2.3.1	Stability Definitions	12
2.3.2	Robustness of Equilibria	15
3	Strategic Analysis of the Great Canadian Hydroelectric Power Conflict	17
3.1	Introduction	17
3.2	History and Background	21
3.2.1	Contract Negotiations	22
3.2.2	Contract Re-Negotiations and Appeals to the Supreme Court of Canada	24
3.2.3	The Lower Churchill Falls Project	25
3.2.4	Contract Automatic Renewal in 2016	25
3.2.5	The Labrador Boundary Dispute	26
3.2.6	Canadian Electricity Policy in Relation to Churchill Falls Development	26
3.3	Conflict Model	27
3.3.1	The First Conflict: Contract Negotiations	29
3.3.2	The Second Conflict: Recall of Power and Price Re-Negotiation	32
3.3.3	The Third Conflict: The Lower Churchill Falls Project	32
3.3.4	The Fourth Conflict: Automatic Renewal Clause	33

3.4	Conflict Analysis: Contract Negotiations (1963-1969)	35
3.4.1	Before Signing the Letter of Intent (1963-1966)	36
3.4.2	From the Letter of Intent to the Final Contract (1966-1969)	37
3.5	Sensitivity Analysis: Contract Negotiations	38
3.5.1	What If Brinco were Financially Secure?	39
3.6	Third Party Intervention: Contract Negotiations	39
3.7	Lessons Learned, Insights, and Conclusions	41
3.7.1	Lessons Learned and Insights	42
3.7.2	Conclusions	42
3.8	Chapter Summary	43
4	Characterization of a Conflict	44
4.1	Introduction	44
4.2	Characterization Categories	45
4.2.1	Modes of a conflict	45
4.2.2	Macro versus Micro Conflict	47
4.2.3	Parameters of a Conflict	47
4.3	Representing Conflict Parameters in the Graph Model	51
4.3.1	The Graph Model for Conflict Resolution	51
4.3.2	The Preference Graph Model	52

4.4	Case Study: the Great Canadian Hydroelectric Power Conflict	53
4.4.1	Modes of the Great Canadian Hydroelectric Power Conflict	54
4.4.2	Parameters of the Great Canadian Hydroelectric Power Conflict	55
4.4.3	Example of the Graph Model versus the Preference Graph Model for Brinco	60
4.5	Conclusions	61
4.6	Chapter Summary	63
5	Robustness of Equilibria in the Graph Model for Conflict Resolution	64
5.1	Background	65
5.1.1	Strategic Conflicts	65
5.1.2	Long-term Conflicts	66
5.1.3	The Graph Model for Conflict Resolution (GMCR)	66
5.1.4	Robustness of Equilibria	67
5.2	Methodology	68
5.2.1	Factors in Equilibrium Robustness	69
5.2.2	Robust Individual Stabilities	72
5.2.3	Ranking of Robustness of Equilibria	74
5.2.4	Insights from Level of Freedom	75
5.3	Case Study: Elmira Groundwater Contamination Conflict	77
5.3.1	Background	78

5.3.2	Modelling of Elmira Groundwater Contamination Conflict	78
5.3.3	Stability Analysis	78
5.3.4	Analysis of Equilibria of Elmira Water Conflict	79
5.4	Conclusions	81
5.5	Chapter Summary	82
6	Multi-Level Options for the Graph Model for Conflict Resolution	84
6.1	Background	86
6.2	Modelling Using Multi-Level Options	87
6.2.1	Evolution of Conflicts	88
6.2.2	Multi-Level Options	90
6.2.3	Analysis of Conflicts with Multi-Level Options	92
6.3	Case Study: The Great Canadian Hydroelectric Power Conflict	94
6.3.1	Modelling with Binary Options	95
6.3.2	Analysis of Binary Options Model	98
6.3.3	Modelling with Multi-Level Options	99
6.3.4	Analysis of the Multi-Level Options Model	101
6.4	Conclusions	102
6.5	Chapter Summary	104
7	Conclusions and Future Research	105
7.1	Modelling for Sustainable Conflict Resolution	105

7.1.1	Characterization of a Conflict	105
7.1.2	The Preference Graph Model for Conflict Resolution	106
7.1.3	Multi-Level Options	106
7.2	Analysis for Sustainable Conflict Resolution	107
7.3	Ideas for Future Research	107
7.4	Publications During PhD Studies	108
7.4.1	Journal Papers	108
7.4.2	Conference Papers	109
7.5	Chapter Summary	111
	References	112

List of Tables

2.1	Foresight of Focal Decision Maker in Different Stability Conditions	14
3.1	Decision Makers and Options in the Contract Negotiations before 1966 . . .	30
3.2	Option Form for Contract Negotiations after 1966	31
3.3	Decision Makers and Options for Recall of Power and Price Re-Negotiation—	33
3.4	Decision Makers and Options for the Lower Churchill Falls Project	34
3.5	Decision Makers and Options for Future Dispute (2016) on Automatic Re- newal Clause of Upper Churchill Falls	34
3.6	Players and Options of the Two Phases of Contract Negotiations	35
3.7	Contract Negotiations before 1966	36
3.8	Equilibria States for Contract Negotiations before 1966	37
3.9	Contract Negotiations after 1966	38
3.10	How Negotiations Moved toward Equilibrium (Y: Yes, N: No)	38
3.11	Contract Negotiations with Brinco in Good Finances	40
3.12	Moving toward Equilibria when Brinco is in Good Finances	40

4.1	Decision Makers, Options, and Preferences of the Great Canadian Hydro- electric Power Conflict (Matbouli et al., 2012b, 2014b)	57
5.1	Foresight of Focal Decision Maker in Different Robust Stability Conditions	74
5.2	Ranking of Equilibrium Robustness	75
5.3	Elmira Conflict: Decision Makers, Options, and States	79
5.4	Elmira Conflict: Decision Makers, Moves, and States	81
5.5	Levels of Freedom and Individual Stability Ranking	81
5.6	Overall Ranking of Equilibria Robustness for the Elmira Conflict	82
6.1	Decision Makers, Binary Options, and Option Levels	96
6.2	Decision Makers, Options, and Outcomes for Churchill Falls Contract Ne- gotiations	96
6.3	Decision Makers' Preferences Ranking over Outcomes of Binary Options . .	98
6.4	Equilibrium States for Binary Options Model	99
6.5	Decision Makers, Multi-Level Options and Selection Levels	101
6.6	Decision Makers, Multi-Level Options, and Outcomes	101
6.7	Decision Makers' Preferences Ranking over Outcomes of Multi-Level Options	102
6.8	Equilibrium States for Multi-Level Options Model	103

List of Figures

1.1	Organization of the Thesis	5
3.1	Churchill Falls, Gull Island, Muskrat Falls, and the Two Transmission Lines	19
3.2	Timeline Showing the Four Phases of the Conflict	28
4.1	Modes of Conflict	46
4.2	Different Conflicts	50
4.3	Connected Rounds of the Same Evolving Conflict	51
4.4	Churchill Falls Location and Transmission Routes	55
4.5	The Graph Model for Brinco	60
4.6	The Preference Graph Model for Brinco	62
5.1	Long-term Conflict	66
5.2	Interrelationships between Robust and Standard Stability Concepts	77
5.3	Graph Model for the Elmira Water Conflict	80
5.4	Possible moves from Equilibria States	82

6.1	Inside-out Evolution of a Conflict	89
6.2	Outside-in Evolution of a Conflict	89
6.3	Analysis for Sustainable Resolution	91
6.4	Modelling and Analysis of Multi-Level Options	93
6.5	Graph Form for Brinco with Binary Options	97
6.6	Graph Form for Québec	97
6.7	Graph Form for Investors	98
6.8	Graph Form for Brinco with Multi-Level Options	102

Glossary of Terms

Brinco	British Newfoundland Development Corporation
DM	A Decision Maker in a conflict (similar to a Player in Game Theory)
Equilibrium	A state which all decision makers involved in a conflict find to be stable
Extensive form	Tree-like representation of decision makers' strategies in a game form
GMCR	Graph Model for Conflict Resolution
GMR	General Metarationality: a stability concept defined in Section 2.3.1 in which all unilateral improvements by a given decision maker can be sanctioned by unilateral moves of other decision makers
Integrated Graph	A single graph that represents unilateral moves available to all decision makers involved in a conflict
Intransitive Preference	If state A is more preferred than B, and B is more preferred than C, but A is not more preferred than C, this is an intransitive preference relation
Irreversible Move	A move from one state to another which cannot be reversed by a decision maker
Level of Freedom	A rough measure of a decision maker's ability to move from any state
Nash Stability (R)	A stability concept defined in Section 2.3.1 in which a decision maker cannot unilaterally improve from a given state
Nearby States	Two or more states that are identical except in the level of one option

Normal Form	A matrix representation of a game in which the rows represent the strategies of one decision maker and the columns the strategies of a second decision maker
Option Form	A table representation of a strategic conflict in which decision makers and their options are given on the left side, and outcomes of feasible states on the right side
Preference	When a decision maker compares two states, one state can be more preferred, equally preferred, or less preferred than the other state
Preference Graph Model	A representation of the graph model where direction of arcs represent transitive preferences of a decision maker over all states in a conflict
Reachable List	The list of states that a decision maker can reach unilaterally in a single step
Reversible Move	For a reversible move, if a decision maker can move unilaterally from state A to state B, then this decision maker must be able to move from state B to state A unilaterally
Robustness	A relative concept in which stability concepts are evaluated based on their resilience to changes in preferences of decision makers
SEQ	Sequential Stability: a stability concept defined in Section 2.3.1 in which all unilateral improvements by a given decision maker can be sanctioned by unilateral improvements of other decision makers

SMR	Symmetric Metarationality: a stability concept defined in Section 2.3.1 in which all unilateral improvements by a given decision maker can be sanctioned by unilateral moves of other decision makers and cannot be recovered
Stability Analysis	Each state is checked for stability for each decision maker according to a range of stability concepts given in Section 2.3.1
Stable State	A state is stable if a decision maker has no incentive to unilaterally move away from that state. More specifically, the state meets any of the stability conditions defined in Section 2.3.1
Status Quo	The initial state of a conflict from which the first move may occur
Strategic Conflict	A conflict between at least two decision makers where each decision maker has at least one option that it controls
Transitive Preference	In a transitive preference, if state A is more preferred than B, and B is more preferred than C, then A must be more preferred than C
UD	Unilateral Disimprovement: a move by a given decision maker from state A to state B where state B is less preferred than A by the decision maker
UI	Unilateral Improvement: a move by a given decision maker from state A to state B where state B is more preferred than A by the decision maker
UM	Unilateral Move: a move by a given decision maker from state A to state B

Chapter 1

Introduction

1.1 Overview

Conflicts take place every day on multiple levels. They can happen in personal life, in government and in business, and they may be local, regional, national, or international. Conflicts can be more or less deadly and costly ([Cranna and Bhinda, 1994](#); [Abadie and Gardeazabal, 2003](#); [Hess, 2003](#); [Omosa, 2005](#)), and can be exemplified by physical fights, games, or debates ([Pieper, 2008](#)). As human civilization develops, conflicts may become less physical confrontations, and more strategic. [Amos \(1880\)](#) predicted that in the future, conflicts will be more humane and wars may disappear because “the immorality of killing humans would be universally recognized” ([Amos, 1880](#); [Pieper, 2008](#)).

More than a century after Amos’ prediction in 1880, wars have not disappeared, but have become more strategic and less random ([Pieper, 2008](#)). Conflicts are more often in the form of games, where the goal of one decision maker (DM) is to outwit rather than to eliminate. Analysis and understanding of conflicts can be obtained from multiple

perspectives, including social, political, psychological, and strategic.

Models of conflict resolution are used to analyze strategic conflicts between two or more DMs (Kilgour and Hipel, 2005). Nonetheless, because many conflicts seem to evolve over time, current modelling techniques may be inadequate for investigating long-term conflicts, despite the importance of assisting DMs and mediators to resolve these conflicts. The many examples of strategic conflicts, which have been formally studied, include the Cuban Missile Crises (Allison, 1969; Fraser and Hipel, 1983; Hipel et al., 2011), the Flathead River conflict (Li et al., 2004), the Salmon Aquaculture conflict (Noakes et al., 2003), and the Great Canadian Hydroelectric Power conflict (Feehan and Baker, 2007; Feehan, 2011; Matbouli et al., 2014b).

1.2 Motivation

The idea of this thesis started with the study of a real life conflict between two Canadian provinces over a water resource that produces a tremendous amount of hydroelectric power (Matbouli et al., 2014b). In particular, the Great Canadian Hydroelectric Power conflict (Feehan and Baker, 2007; Feehan, 2011; Matbouli et al., 2012b, 2014b) is a long-term conflict that evolved over time and was not resolved at historically-reached equilibria over time. These equilibria were temporary and the conflict continued. This conflict, which is strategically analyzed in Chapter 3, expressed itself in several rounds at different points in time.

Although the Graph Model for Conflict Resolution (GMCR) (Fang et al., 1993; Hipel, 2009a,b; Kilgour and Eden, 2010; Hipel et al., 2011) has provided some insightful results, it does not explain why some conflicts tend to continue even after reaching an equilibrium. Can an equilibrium fail to be a resolution? Would a different equilibrium have caused

the conflict to stabilize and not evolve? Despite the fact that all rounds of the conflict are closely related, they must be treated separately in GMCR. Therefore, in view of the aforementioned limitations, it is important to develop a model that unifies the treatment of long-term conflicts, to refine the definition of an equilibrium such that a resolution should be sustainable, and to provide insights into how a conflict may evolve over time.

1.3 Objectives

The aim of this research is to study how conflict resolution can be made sustainable. A resolution that is sustainable is a resolution that is an equilibrium, which is not temporary but permanent. To accomplish this goal, it will require refinements to the definition of an equilibrium in GMCR, and a framework to model and treat rounds of a conflict together as one, in order to provide DMs with insightful conflict resolution information.

In summary, the objectives are

- Understand why some equilibria are temporary,
- Enhance the GMCR to account for the evolution of conflicts,
- Develop a measure to evaluate robustness of equilibria.

1.4 Organization of the Thesis

This thesis is divided into seven chapters as shown in Figure 1.1. *The first Chapter* is an introduction to the objectives and motivation of this thesis. In *Chapter 2*, literature on

conflict theory and the development of conflict models are summarized. Chapters 3 to 6 contain the research carried out to achieve the objectives of the thesis, as outlined below:

Chapter 3 presents a strategic analysis of the Great Canadian Hydroelectric Power conflict that motivated this research. This work shows an application of the original GMCR to an ongoing long-term conflict. It was used as a case study to identify and test needed improvements to the graph model. This chapter is based on three published papers by [Matbouli et al. \(2012a,b, 2014b\)](#).

Chapter 4: Characterization of a Conflict provides a descriptive model of a conflict in general and gives some insights into the common characteristics of long-term conflict. Also included is an enhancement of the original graph model that illustrates the preferences of DMs right on the graph. This work is largely based on [Matbouli et al. \(2013a, 2014d\)](#).

Chapter 5: Robustness of Equilibria in the Graph Model for Conflict Resolution presents a fresh concept that measures the robustness of equilibria in conflict resolution. This chapter introduces Level of Freedom to tackle the dilemma of equilibrium robustness in conflict resolution. This chapter is largely based on published papers by [Matbouli et al. \(2013c, 2014a, 2015c\)](#).

Chapter 6: Multi-Level Options in the Graph Model for Conflict Resolution In this chapter, a new structure of options is proposed to make modelling in GMCR more expressive of reality. An expansion to the traditional binary option structure to allow multiple levels of option selections is proposed. Finally, in *Chapter 7*, a summary of contributions, ideas for future research, and concluding remarks are presented.

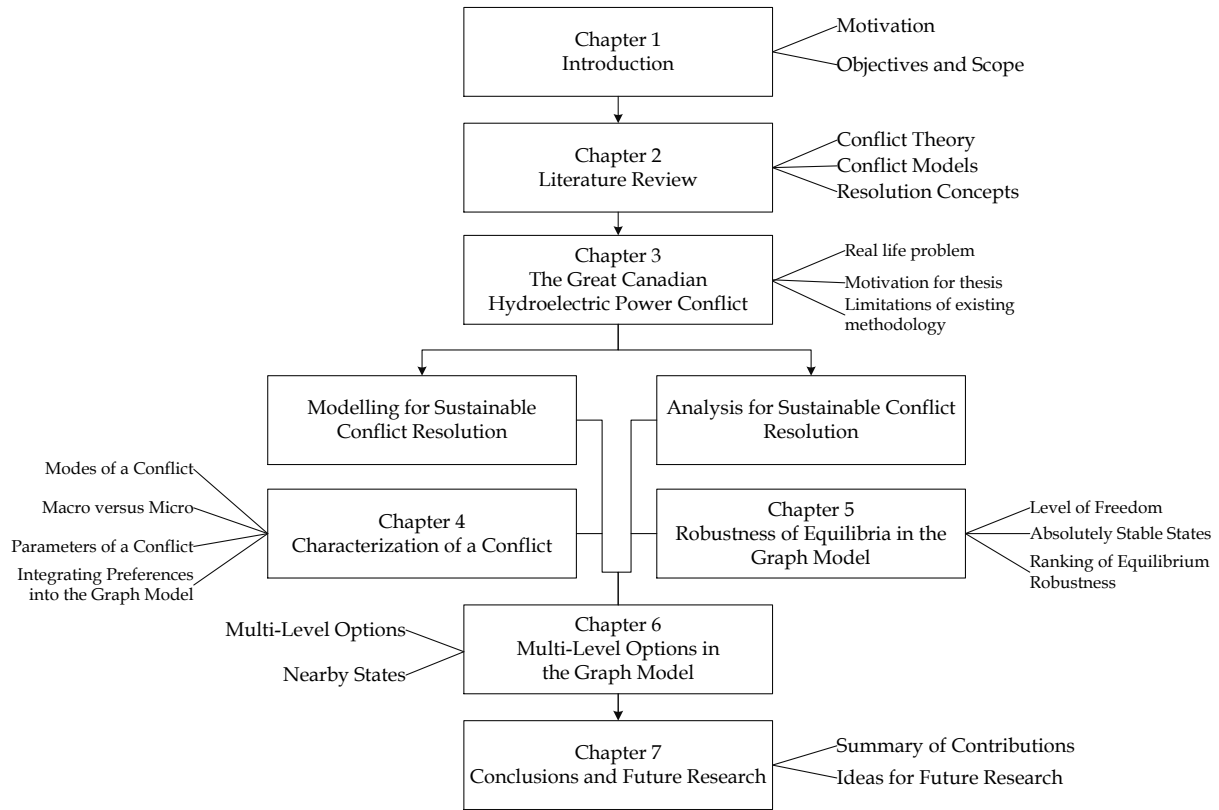

Figure 1.1: Organization of the Thesis

1.4.1 Thesis Integration

Although each methodology chapter (4 to 6) represents a distinct contribution, together these chapters contribute to the original goal as stated in the title of this thesis—Sustainable Conflict Resolution: Modelling, Analysis, and Strategic Insights—in two general directions: modelling and analysis.

Enhancements to the modelling aspects of conflict resolution are presented in Chapters 4 and 6. In *Chapter 4*, an initial characterization procedure is proposed to assist in understanding the time status of a conflict and its evolution, including improvement to illustration features of the graph model to make preferences visible in the graph. This

advancement is expected to enhance the visual comprehension of a conflict by an analyst or a DM. Then, in *Chapter 6*, a new concept of multi-level options is introduced to the graph model in order to make the model more expressive of reality.

On the other hand, contributions to the analysis capabilities of the graph model are presented in *Chapter 5*, where a fresh concept of robustness of equilibria within the graph model is proposed for the first time. This chapter presents a methodology that will enable an analyst to differentiate among equilibria based on their robustness or resiliency to change. Finally, in the concluding chapter, a discussion of the contribution of the presented methodologies is presented.

Chapter 2

Literature Review

In this chapter, a review of literature related to conflict resolution and modelling is presented. First, a brief introduction about the theory of conflict is given. Then, a summary of conflict resolution models and solution concepts is discussed.

2.1 Conflict Theory

Conflict is a complex and dynamic phenomenon ([Jeong et al., 2008](#)). A strategic conflict occurs when two or more decision makers (DMs) pursue incompatible goals ([Galtung, 2008](#)). In a formal definition, conflict is a special form of incompatibility where the variables are the goals, and units are the actors ([Galtung, 2008](#)).

A conflict is also a contradiction where the acceptability region is located in the incompatibility region ([Galtung, 2008](#)). Simply, a conflict is about incompatible goals. Goals in conflicts are often dimensional. For a gradient goal, the drive for conflict or the motivation to continue pursuing the goal is variable along the line of the goal ([Galtung, 2008](#)). This

means that achieving a goal in a conflict is not necessarily described in a binary relation; instead, achieving a goal can be described in a continuous, discrete, or fuzzy manner, as there are different levels of achieving the goal in a conflict. This concept enables the compromise where a DM partially accomplishes a goal as a result of engaging in a conflict.

On the other hand, actors, DMs or players in a conflict can be individuals; groups of people; highly structured organizations, such as companies and governments; or sets of these actors such as societies or nations (Galtung, 2008).

Conflicts may be vertical or horizontal (Galtung, 2008). In a vertical conflict, one DM is superior to others. Three features of a vertical conflict are: unequal exchange, penetration, and fragmentation. In an unequal exchange, a vertical structure exists among the DMs. For example, a manager and a reporting employee. Penetration happens when a DM influences the goal realization of another. For instance, in a well-controlled media, the government may choose to determine the topics of interests for its citizens. Fragmentation, on the other hand, is the ability of a superior DM to prevent coalition among other individuals or groups. Therefore, a conflict may be partially vertical when some of the aforementioned features exist. Nevertheless, due to the dynamic nature of conflict, a conflict may start as a vertical and move toward horizontal. An example of that scenario is shown in revolution against dictatorships, where the centralized government controls the perception of freedom and justice, and acts against gatherings among its people. When a revolution starts, it begins in a weak position but may become equally powerful, leading to the features of horizontal conflicts, where there is equity in the division of power, equal realization of goals, and equal ability to form coalitions and associations with other DMs (Galtung, 2008).

Additionally, conflicts take place in one of three forms: fights, games, and debates (Rapoport, 1974; Pieper, 2008). These three forms are categorized based on the goals of the conflict. In fights, the goals of DMs are to eliminate, harm, or incapacitate their

opponents (Rapoport, 1974; Pieper, 2008). In games, the aim of DMs is to outwit each other without necessarily harming them. Finally, in debates, it is neither the aim to harm or outwit, but rather to bring different opinions closer together by means of communications (Pieper, 2008). As modernity and civilization develop, conflicts tend to be more like games and debates, rather than fights (Amos, 1880). Even now, fights are less physical and more strategic (Pieper, 2008). There are two features that distinguish games. First, in games there are no physical interactions, ruling out violence. Second, DMs in games adhere to certain rules that are either imposed within a given environment or agreed upon by all DMs (Pieper, 2008).

2.2 Conflict Resolution Models

Generally decision-making problems can be categorized based on the number of DMs and objectives. In a situation where a single DM has one objective, linear and dynamic programming methods can be used to optimize making decisions (Hipel, 1992a,b). Conflicts are decision problems where multiple DMs and multiple objectives exist. This is a more complex form of decision problem; yet, it is the least researched topic among other types of decision-making scenarios (Fang et al., 1993).

A conflict resolution model is an abstract of a real life conflict where two or more DMs are engaged in a dispute (Fang et al., 1993; Hipel, 2009a,b; Kilgour and Eden, 2010). Modelling conflicts fall under noncooperative game theory where DMs act independently (Fang et al., 1993; Hipel and Obeidi, 2005). There are a number of ways to model a conflict: normal form (Von Neumann and Morgenstern, 1944), extensive form (Von Neumann and Morgenstern, 1944; Kuhn, 1953), option form (Howard, 1971), and the graph model (Kilgour et al., 1987; Fang et al., 1993; Hipel, 2009a,b; Kilgour and Eden, 2010; Hipel et al.,

2011).

The normal form is usually used to present a two-person game in a matrix, where the columns represent strategies available to one player, and the rows represent strategies available to the other. Each cell represents a combination of column and row strategy, which is useful to present compact games. In the normal form, all moves seem reversible, which is not always the case. An improvement over the normal form is the extensive form, which is a tree-like format that shows moves when they are available unilaterally. Nonetheless, because the extensive form branches out to show every possible move from each node, a conflict presented this way can be very large and hard to work with. In contrast, the option form, which uses a tabular format, can present large games (Wang et al., 1989), but lacks the ability to illustrate limitations in moves and countermoves. The option form is widely used to model conflicts (Howard, 1971; Fang et al., 1993). Finally, the graph model is the most advanced form to present moves that are possible for a DM, reversible, irreversible, or common. It also handles cardinal as well as ordinal preferences of DMs. The graph model can be used to present the moves of one DM, or combined to present the collective moves and countermoves of all DMs (Kilgour et al., 1987; Fang et al., 1993; Kilgour and Hipel, 2005; Inohara and Hipel, 2008a,b; Hipel, 2009a,b; Kilgour and Eden, 2010; Hipel et al., 2011).

2.3 The Graph Model for Conflict Resolution (GMCR)

The Graph Model for Conflict Resolution (GMCR) (Kilgour et al., 1987; Fang et al., 1993; Kilgour and Hipel, 2005; Hipel, 2009a,b; Kilgour and Eden, 2010; Hipel et al., 2011) is a systematic chess-like approach that is used to analyze strategic conflicts. GMCR uses solution concepts inspired by game-theoretic equilibrium definitions in order to model

interactions amongst DMs under conflicts. The use of GMCR has several advantages over classical game-theoretic approaches in the analysis of conflicts. First, GMCR is flexible in representing large conflicts, compared to normal or extensive games. Additionally, conflicts represented in GMCR can handle moves that are not only reversible, but also irreversible or common. Moreover, GMCR can represent complex preference structures of DMs, such as cardinal, transitive, and intransitive preferences.

Definition 1. A graph model for conflict resolution is defined as $G = \langle N, S, \{A_i\}_{i \in N}, \{\succ_i, \prec_i, \sim_i\}_{i \in N} \rangle$, where N is the set of all DMs, S is the set of feasible states, A_i is the set of unilateral moves available for DM i such that $A_i \subseteq S \times S$, and $\{\succ_i, \prec_i, \sim_i\}$ represents DM i 's preference relation, such that for any $s, q \in S$, $s \succ_i q$ means state s is more preferred by DM i than state q , $s \prec_i q$ indicates that state s is less preferred for DM i than state q , and $s \sim_i q$ means DM i is indifferent between state s and state q .

Definition 2. In a graph model G , the reachable list for DM i (Fang et al., 1993) $i \in N$ from state $s \in S$ denoted by $R_i(s) = \{q \in S : (s, q) \in A_i\}$, is the set of states to which DM i can move unilaterally from state s . Similarly, the unilateral improvement (UI) list of moves is denoted by $R_i^+(s)$, is a subset of $R(s)$ defined by $\{q \in R(s) : q \succ_i s\}$. The lists $R_i^-(s) \subseteq R(s) \ni \{q \in R(s) : q \sim_i s\}$ and $R_i^-(s) \subseteq R(s) \ni \{q \in R(s) : q \prec_i s\}$ are defined analogously such that $R_i^+(s) \cup R_i^-(s) \cup R_i^-(s) = R_i(s)$.

Hence, if there is a move between states s and q such that $s \sim_i q$, the move is considered a *unilateral move (UM)* available to DM i between indifferent states, and it is denoted by $R_i^-(s)$. Moreover, in case $s \succ_i q$, the move from s to q is considered a *unilateral disimprovement (UD)* and it is denoted by $R_i^-(s)$.

The resolution of a conflict is assumed to take place when the conflict becomes stable, as is assumed based on several sociological scenarios (Fang et al., 1993). From DM's

position in a conflict, systematic what-if questions can be asked to investigate the available choices. When all DMs find a certain scenario of a conflict acceptable, then this scenario is considered a possible resolution or equilibrium.

2.3.1 Stability Definitions

There are a number of stability concepts used in conflict resolution. Considering the preferences of DMs, their available moves and countermoves, and stability definitions identify the likelihood of a state being accepted. For example, a DM who cannot unilaterally improve to a more preferred state, his or her state is considered stable for this particular DM. The previous example is called Nash stable (R) (Nash, 1950, 1951). However, a state that is stable for one player may not necessarily be stable for others. A resolution exists only when an equilibrium is reached, which happens when all DMs find the same state to be stable.

Other stability definitions include general metarationality (GMR) (Howard, 1971), symmetric metarationality (SMR) (Howard, 1971), sequential stability (SEQ) (Fraser and Hipel, 1979, 1984), limited-move stability (L_h) (Zagare, 1984; Kilgour, 1985; Kilgour et al., 1987), and nonmyopic stability (NM) (Brams and Wittman, 1981; Kilgour, 1984, 1985; Kilgour et al., 1987). The foresight by which these stability definitions investigate what-if scenarios is different. In Nash stability, the oversight is considered low (Fang et al., 1993) because it considers only one move beyond present point. GMR and SEQ take into account one step further to examine countermoves, and SMR two steps. Limited-move stability has variable foresight; the analyst defines the horizon, or number of foreseeable steps. Finally, nonmyopic stability provides the highest level of foresight. It extends limited-move stability to take into account all possible steps beyond a certain state (Fang et al., 1993). Nonetheless, both limited-move and nonmyopic stability assume transitive preferences.

Primary stability concepts, defined below, are used to analyze DM's stability in a conflict throughout this thesis when needed. These stability concepts include Nash (Nash, 1950, 1951), sequential sanctioning (SEQ) (Fraser and Hipel, 1979, 1984), general metarational (GMR) (Howard, 1971), and symmetric metarational (Howard, 1971). First, the Nash stable states for $i \in N$, $S_i^{Nash} \subseteq S$ are defined as follows:

Definition 3. For $i \in N$, state $s \in S_i^{Nash} \iff R_i^+(s) = \emptyset$.

Thus, a state $s \in S$ is *Nash stable* for DM $i \in N$ if and only if (iff) DM i has no UI from s . In *Nash stability*, a DM looks one move ahead from the present state, considering only his or her own preference.

The next definition, *sequential stability (SEQ)*, extends the consideration for DM i 's foresight to two moves, where the DM takes into account possible sanctions of a UI by other DMs.

Definition 4. For $i \in N$, state $s \in S_i^{SEQ} \iff \forall q \in R_i^+(s), \exists x \in R_{N-i}^+(q) \ni x \succsim_i s$.

A state s is *sequentially stable* for DM i iff any UI from state s is sanctioned by a countermove from DM $N - i$, where $N - i$ is the set of all DMs except i . Note that any Nash stable state is sequentially stable, and hence, $S_i^{Nash} \subseteq S_i^{SEQ}$.

The difference between *SEQ* and *GMR*, which is defined below, is that in *SEQ*, the threat to sanction a UI is credible because it will result in an improved position for the sanctioning DM, whereas, in *GMR*, the sanctioning DM does not consider his or her own benefit. *GMR* is a more conservative stability definition; therefore, it is a weaker stability concept than *SEQ*.

Definition 5. For $i \in N$, state $s \in S_i^{GMR} \iff \forall q \in R_i^+(s), \exists x \in R_{N-i}(q) \ni x \succsim_i s$.

Table 2.1: Foresight of Focal Decision Maker in Different Stability Conditions

Stability Definitions	Foresight	Focal DM	Opponent DM
Nash (r)	One move	UI	-
Sequential Stability (SEQ)	Two moves	UI	UI
General Metarationality (GMR)	Two moves	UI	UI, UD
Symmetric Metarationality (SMR)	Three moves	UI	UI, UD

A state $s \in S$ is *general metarational (GMR)* for $DM i$, if and only if any UI by $DM i$ from state s to q is sanctioned by a unilateral move (UM) by any $DM N - i$ from q to x such that state x is not more preferred than state s by $DM i$. When the *GMR* definition is extended to see if the focal DM is able to recover from sanctioning, the result is the definition of *SMR stability*, in which the focal DM cannot escape from a sanction.

Definition 6. For $i \in N$, state $s \in S_i^{SMR} \iff \forall q \in R_i^+(s), \exists x \in R_{N-i}(q) \ni x \succsim_i s \wedge \forall h \in R_i^+(x) \ni h \succsim_i s$.

A resolution is reached when a state that is stable for all DMs is reached. Such a state is called an *equilibrium*. A conflict may have more than one equilibrium.

Definition 7. $s \in S^{equilibrium} \iff s \in S_N^{Stable} \ni S_N^{Stable} = S_N^{Nash} \cup S_N^{SEQ} \cup S_N^{GMR} \cup S_N^{SMR}$.

In Table 2.1, a summary of the numbers and types of moves the focal DM considers in the various stability concepts is given. For example, in Nash stability, the focal DM considers only his or her own possible UIs, while in SEQ the focal DM also considers UIs by opponents. After incorporating robustness in the stability definitions, the contents of Table 2.1 will be extended to consider additional foresight or moves that are not necessarily UIs.

2.3.2 Robustness of Equilibria

Since GMCR utilizes stability principles similar to those in game theory, it is appropriate to look at the robustness of equilibria in game theory. In GMCR, DMs make their moves and countermoves according to relative preferences for the various states produced by different combinations of their options. States represent possible outcomes of a round of a conflict that takes place at a single point in time. Other stages of conflict evolution are analyzed either separately, or jointly as one conflict over an extended time period. In game theory, an analyst may reject certain Nash equilibria because they are counter intuitive (Fudenberg et al., 1988). It is possible that, for any given game, agreement over which equilibria are more stable might be “a matter of taste” (Kohlberg and Mertens, 1986). More formalized methodologies to investigate or further restrict Nash equilibrium are proposed, including perfect equilibrium (Selten, 1975), proper equilibrium (Myerson, 1978), strategically stable equilibrium (Kohlberg and Mertens, 1986), and robust equilibria of potential games (Ui, 2001). The objective of equilibrium refinement and robustness in game theory is to find the most stable, robust, or likely equilibria.

Concepts such as perfect equilibrium (Selten, 1975) and proper equilibrium (Myerson, 1978) further restrict a Nash equilibrium by imposing probabilistic weights on opponents strategies. In a Nash equilibrium, a player is assumed to think only of his or her strategy without considering the opponents strategies. Assigning weights to opponents’ strategies may help to avoid unlikely Nash equilibria. Such methods in a game theory setting are designed to maximize players’ payoffs. It is also noteworthy to mention that robustness of an equilibrium in a game theory setting was utilized in the extensive or normal form of games and never in the graph model. Nevertheless, the purpose of an investigation of equilibrium robustness differ in this research in the sense that we are not interested in the highest payoff, but want to find an equilibrium that is stable enough to be a sustainable

resolution of conflicts.

Chapter 3

Strategic Analysis of the Great Canadian Hydroelectric Power Conflict

A long-term conflict is analyzed using the original graph model. This real life example provided the motivation for this thesis. Limitation in modelling and analysis of this conflict inspired the methodology in Chapters 4 to 6. This chapter is largely based on three publications by [Matbouli et al. \(2012a,b, 2014b\)](#).

3.1 Introduction

Canada has a great and diverse energy potential, including oil, nuclear, wind and hydropower energy sources ([Robinson, 1987](#)). However, provincial conflicts could hinder the development of Canada's energy sector. Churchill Falls hydroelectric power is the subject

of a prolonged controversy among politicians of two Canadian provinces: Newfoundland and Labrador (NL), and Québec (QC) (Churchill, 2003; Feehan and Baker, 2007; Feehan, 2011; Matbouli et al., 2012a,b, 2014b). Although the long-term of the contract encouraged investment, it may have weakened the development of the hydroelectric energy sector. A well-functioning national energy sector requires a cross-provincial regulator to ensure proper integration of resources and to avoid monopolies (Hauteclocque and Glachant, 2009).

The conflict concerns the exploitation of an enormous source of hydroelectric power, the Churchill Falls Hydro site, one of the world largest hydroelectric generation stations with a current capacity of more than 5400 MW (Nalcor Energy, 2011a). An additional project, the Lower Churchill Falls, will add over 3000 MW (Nalcor Energy, 2011b). The current Churchill Falls power exceeds twice the output of the Canadian side of Niagara Falls, and exceeds the total output of the Niagara Falls power generation, see (Nalcor Energy, 2011a,b; Ontario Power Generation, 2012). The Churchill Falls site is located in the Labrador territory of NL, far from the populated areas in the province. However, Churchill Falls is located close to the QC border, at a distance of about 180 km (Feehan and Baker, 2007), (see Figure 3.1).

The Churchill Falls Hydroelectric power generation station is operated by Churchill Falls Labrador Corporation (CFLCo) (Feehan and Baker, 2007), of which NL owns 65.8% and QC the remaining 34.2%. Most of the power has been sold to QC at a low price (Hydro-Québec and Churchill Falls (Labrador) Corporation Limited, 1969; Feehan and Baker, 2007; Matbouli et al., 2012a,b, 2014b). The NL government views the contract as unfair and unethical (Churchill, 2003; Feehan and Baker, 2007). Moreover, many Newfoundlanders and Labradorians think of this contract as another instance where their resources are being “exploited by outsiders” (Feehan and Baker, 2007), as the NL government cannot increase

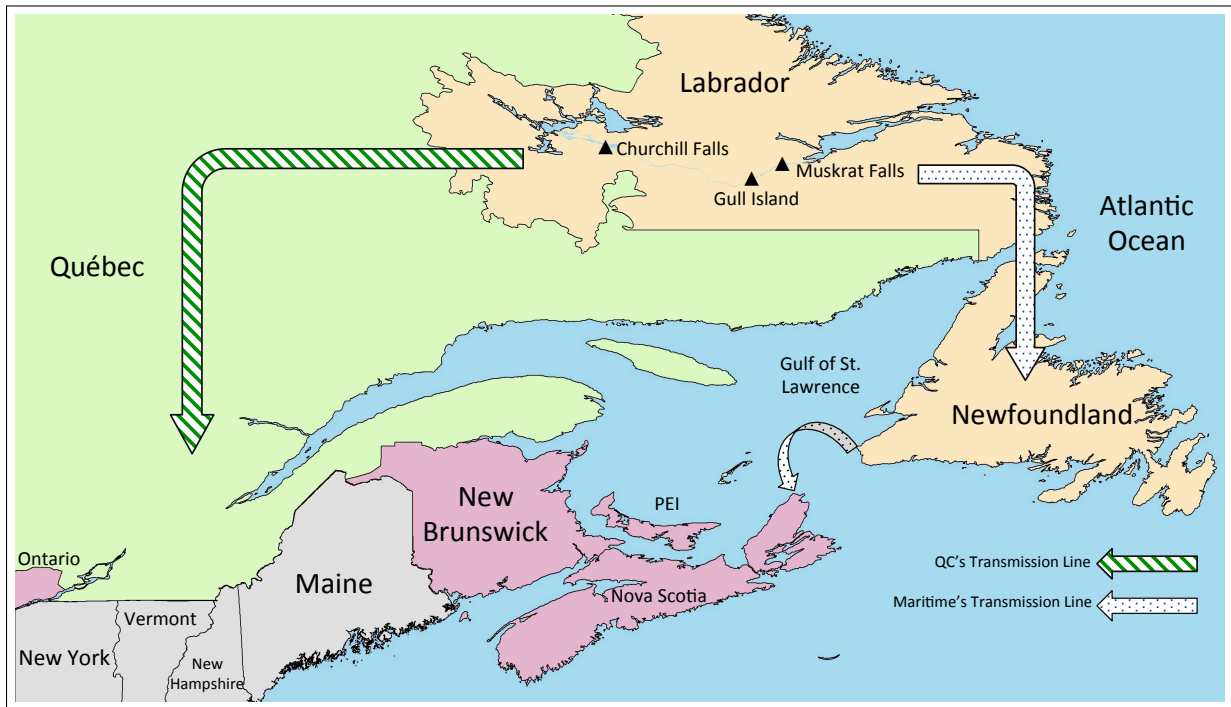

Figure 3.1: Churchill Falls, Gull Island, Muskrat Falls, and the Two Transmission Lines

the price to reflect the current market, nor can it reclaim any of the power for its own use. Finally, NL cannot cancel the contract until it expires. QC, on the other hand, views this contract as a legitimate deal, agreed upon by both sides and appropriate, given the uncertainty in the market when it was signed.

Various NL governments challenged the agreement in many ways. NL appealed twice to the Supreme Court of Canada ([The Supreme Court of Canada, 1988a,b](#)), which affirmed in both cases that the contract was valid. In addition, other aspects of the conflict originate from the initial contract and the desire of NL to develop an adjacent hydroelectric power source, Lower Churchill Falls.

The conflict over the Churchill Falls power generation station has seen several rounds since the 1960s. The length of this conflict reflects its very long duration-44 years, with an

additional automatic renewal for 25 more years.

There are three main issues in the original conflict:

1. The very low price at which NL must sell energy to QC, a price that even drops after the renewal.
2. The duration of the contract, including the renewal clause.
3. The inability of NL to reclaim energy for its own use.

The conflict is analyzed using the Graph Model for Conflict Resolution (GMCR) (Kilgour et al., 1987; Fang et al., 1993; Kilgour and Hipel, 2005; Hipel et al., 2011). GMCR has been applied in the analysis of various conflicts (Savich et al., 1983; Xianpei et al., 1988) and negotiations (Sheikhmohammady et al., 2010) and proven to provide insights on the stability of conflicts, and the movement of each decision maker (DM) involved. The systematic approach of GMCR has been applied to the Great Canadian Hydroelectric conflict in order to understand how it affected the development of the Churchill Falls project and its impact on the further development of the remaining hydropower potentials of the Churchill river.

The study of this conflict has important lessons for policy making. It provides insights into the problems associated with long-term contracts and their effect on the public interest. The lengthy duration of the contract even exceeds what is suggested for long-term take-or-pay contracts (Johnston et al., 2008).

3.2 History and Background

NL is Canada's newest province. Soon after joining Canada in 1949, the government of NL aimed to boost its economy up to the level of other provinces. In 1953 (Feehan and Baker, 2007), with the help of British industrialists and bankers, the NL government established the British Newfoundland Development Corporation (Brinco) (Smith, 1975), in order to develop industrial opportunities in the province. The land and water rights leased by the NL government to Brinco for a 99 year term included the hydroelectric potential of the waterfalls on the upper reaches of the Churchill River, formerly known as the Hamilton River and renamed in 1965 (Feehan and Baker, 2007).

In 1958, in order to develop and operate the Upper Churchill Falls hydroelectric project (Matbouli et al., 2012a,b, 2014b), Brinco established a federally incorporated subsidiary called the Hamilton Falls Power Company and later renamed Churchill Falls (Labrador) Corporation (CFLCo) (Feehan and Baker, 2007; Smith, 1975). Shawinigan Engineering, a private engineering firm based in QC, purchased a 20% stake in CFLCo. Referencing CFLCo and Brinco is interchangeable, and some executives held positions in both companies (Feehan, 2011).

The purpose of the development of the Upper Churchill Falls project was to sell energy in the adjacent province of QC and beyond, more specifically, to Ontario-Hydro and Consolidated Edison Company of New York (Feehan, 2011); Figure 3.1 shows potential buyers and routes in Canada and the United States. In order for CFLCo to undertake the development and secure finances, it had to transmit electricity from the generation site to buyers. It had two alternatives: either transmit power through QC using a relatively short and economical transmission line (see Figure 3.1), or undertake a challenging and financially unattractive transmission line on what is known as the Maritimes route (Feehan,

2011) or the Anglo-Saxon route (Feehan and Baker, 2007), transmitting power through two subsea cables, from Labrador to the island of Newfoundland and then to Nova Scotia and from there to the rest of Canada and the United States.

3.2.1 Contract Negotiations

Because the Upper Churchill Falls hydropower project is huge and beyond the local market needs in NL, Brinco had to provide a long-term sale agreement in order to secure finances for the project (Feehan, 2011). Brinco considered selling power to Hydro-Québec, Ontario-Hydro, and Consolidated Edison Company of New York (Feehan, 2011) by transmitting power via QC. In 1962, QC started a provincial nationalization process of its private electric utility companies, which resulted in forcing Shawinigan Engineering to sell its share in CFLCo, which came under the control of Hydro-Québec (Feehan, 2011). After serious negotiations between Brinco, through its subsidiary CFLCo, and Hydro-Québec started in 1963, it became apparent to Brinco that transmitting power through QC to interested buyers elsewhere was an almost infeasible option (Feehan and Baker, 2007). QC refused to grant Brinco the right-of-way to transmit power via QC. Instead, QC offered to buy all the power generated at the Upper Churchill Falls hydroelectric site at the border point. Under this condition, Brinco and NL considered avoiding the QC route altogether and funded a study to examine the possibility of transmitting power via the Maritimes route (Feehan, 2011). Although the Maritimes route was technically feasible, it was uneconomical (Feehan and Baker, 2007; Feehan, 2011). Then the negotiations moved toward an agreement in which CFLCo would sell the power on a long-term basis to Hydro-Québec. In 1966, after difficult negotiations (Feehan, 2011), an extensive letter of intent between CFLCo and Hydro-Québec was signed (Feehan and Baker, 2007).

Although some preparation and light construction work began in 1963, the year 1966

marks the official launch of substantial construction of the site (Feehan and Baker, 2007; Feehan, 2011). Meanwhile, funds started flowing into the project, in anticipation of the final and definitive agreement between CFLCo and Québec Hydro-Electric Commission (Hydro-Québec and Churchill Falls (Labrador) Corporation Limited, 1969). The move by QC to nationalize Hydro-Québec and Shawinigan Engineering, brought the Government of QC into both sides of the negotiation, as it was both a seller and buyer. When the Government of QC took over the management of Shawinigan Engineering, it gained an insider view of the negotiations because it would see the challenges facing CFLCo, which provided an advantage to the Government of QC. Some concerns were raised by Brinco whether this move had a conflict of interest, which was partially remediated in the negotiations by inviting the NL government to purchase 8% stake in CFLCo (Feehan and Baker, 2007).

QC's stronger position in the negotiations resulted in changes to the terms of the letter of intent signed earlier by both parties. The QC government, represented by Hydro-Québec, moved slowly towards a definitive contract, resulting in financial disaster for CFLCo, as money stopped flowing into the ongoing construction, and the company was unable to pay its bills (Feehan and Baker, 2007).

A deal described as “do or die” by the CEO of CFLCo (Feehan and Baker, 2007) was reached. This definitive contract, signed in 1969, caused great difficulties for CFLCo. The duration of the contract was extended from the initial proposal of 30 or 35 years to 44 years, with an automatic renewal clause; previously, only mutually agreed-upon renewal was possible (Feehan and Baker, 2007). A few years later, as part of its protest against the contract, the NL government purchased all shares of Brinco in CFLCo and became a direct player with QC in the Churchill Falls Project. Today, although the NL government owns about two-thirds of CFLCo, the QC government represented by Hydro-Québec earns about 50 times the NL government does from selling electricity (Feehan and Baker, 2007).

Hydro-Québec buys electricity at about \$2.5 per MW and exports it at an average rate exceeding \$80 per MW ([Feehan and Baker, 2007](#)).

3.2.2 Contract Re-Negotiations and Appeals to the Supreme Court of Canada

In the early 1970s, the NL government expressed its dissatisfaction with the contract signed between CFLCo and Hydro-Québec. From the early 1970s to the late 1980s, the NL government made several attempts to rectify the deal, including:

1. Purchasing Brinco's share in CFLCo to gain direct control of CFLCo. CFLCo has two owners: NL (65.8%) and QC (34.2%),
2. Requesting re-negotiating of the contract with QC,
3. Appealing to the Canadian Public,
4. Appealing to the Supreme Court of Canada,
5. Creating the "Upper Churchill Water Rights Reversion Act" to reclaim some of the energy produced.

However, all of these attempts were unsuccessful. QC refused to re-negotiate the contract, and the Supreme Court of Canada affirmed twice that the contract was valid ([The Supreme Court of Canada, 1988a,b](#)). Moreover, the Supreme Court of Canada overruled a new act that the NL government tried to impose ([The Supreme Court of Canada, 1984](#)).

3.2.3 The Lower Churchill Falls Project

Beginning in 2003, the NL government put further effort into hydroelectric power development in order to exploit the remaining potential of the Churchill River water resources at Gull Island and Muskrat Falls (see Figure 3.1), leading to the Lower Churchill Falls project that is currently under development. The existing Upper Churchill Falls generation station harnesses about 65% of the potential of the Churchill River (Nalcor Energy, 2011b). The Lower Churchill Falls Project aims to harness the remaining 35% (Nalcor Energy, 2011b), adding more than 3000 MW to existing production and bringing the total production when Lower Churchill Falls is completed to 8500 MW. In order to achieve this, two new installations are planned at Gull Island and Muskrat Falls. For the Lower Churchill Falls project, NL was eager to secure a financially viable agreement and to avoid the mistakes of the Upper Churchill Falls contract. NL filed an application to use QC transmission facilities, which was later rejected (Government of Newfoundland and Labrador, 2010). It contested the rejection in a QC court but was unsuccessful (Premier Danny Williams, 2010; Government of Newfoundland and Labrador, 2010). The federal government intervened and backed the NL proposal to secure finances for the Maritimes route, which is now the main option NL is undertaking (CBC News, 2011).

3.2.4 Contract Automatic Renewal in 2016

In 2016, the contract for the Upper Churchill Falls is due for an automatic 25-year renewal, which is expected to cause a new conflict between NL and QC (Feehan and Baker, 2007). The automatic renewal clause is unexplainable (Feehan and Baker, 2007): there is no justification given in the contract. The NL government will very likely challenge it, especially because it sets the prices even lower than the initial contract, and may therefore result in

long-term financial losses (Feehan and Baker, 2007). In fact, the new price may not be enough to cover the operational expenses of the project (Feehan and Baker, 2007).

3.2.5 The Labrador Boundary Dispute

It is noteworthy that the borders of the Labrador territory of NL were a subject of dispute with Canada before NL became a province. Churchill Falls lies in what used to be the disputed zone between QC, represented by the Federal Government of Canada, and the Dominion of Newfoundland. The Judicial Committee of the Privy Council settled that dispute in favour of Newfoundland in 1927 (Judicial Committee of Great Britain Privy Council, 1927; McEwen, 1982). However, during the negotiations between NL and QC in regard to the development of Upper Churchill Falls, QC brought the issue to the table and suggested a resolution based on a territorial exchange, but this was not considered further because NL refused to negotiate such a resolution (Feehan, 2011).

3.2.6 Canadian Electricity Policy in Relation to Churchill Falls Development

Churchill Falls development was encouraged in 1962 when the federal government allowed export of electricity from Canada, which made Consolidated Edison Company of New York an interesting option for Brinco (Feehan, 2011). However, when NL investigated the possibility of using QC land to transmit power to interested buyers, QC indicated that their interest would be possible only if QC purchase all the power at the border and have the right to resell it at market price (Feehan, 2011). It has been argued that QC's denial of the right of way to NL was unconstitutional according to Section 92.10 (a) of the British North America Act of 1867 in which the federal government has jurisdiction over any "Un-

dertakings connecting the Province with any other or others of the Provinces, or extending beyond the limit of the Province” (Department of Justice, Canada, 1983; Feehan, 2011). NL claims that the federal government placed Hydro-Québec in a “monopolistic” position in the negotiations by failing to enact Section 92.10 (a) of the constitution (Churchill, 2003). On the other hand, as per Section 92.13 of the Constitution Act, QC should have jurisdiction over its property rights (Department of Justice, Canada, 1983; Feehan, 2011). In 1959, the federal government created The National Energy Board (NEB) which did not cover inter-provincial control of electricity (Feehan, 2011).

3.3 Conflict Model

The Churchill Falls conflict is a long-term conflict (Matbouli et al., 2013a) that has seen many changes. The decision makers (DMs), their options, and their preferences have changed over the course of the conflict. To model the conflict systematically, it is divided into four main phases, based mainly on time; there are two historical conflicts, one current conflict, and one future conflict (see timeline in Figure 3.2):

- Phase 1. Contract Negotiations (1963-1969): The contract negotiations can be divided into two rounds:
 1. Before the signing of the letter of intent (1963-1966): During this period initial proposals were exchanged between CFLCo and Hydro-Québec. The focus is to show the evolution of their conflict.
 2. After the letter of intent and before the final contract was signed (1966-1969): In this period, there were significant changes to the original proposals, including the

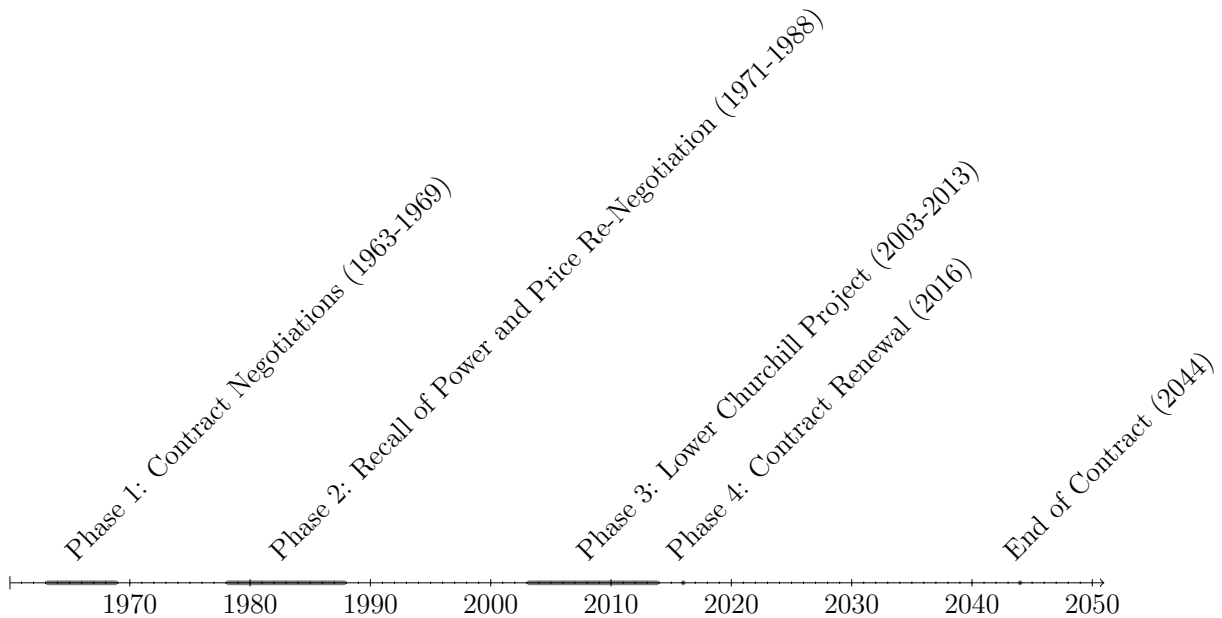

Figure 3.2: Timeline Showing the Four Phases of the Conflict

automatic renewal clause and changes in DMs, options and conflict of interest issues, as well as an extension of the duration of the contract.

- Phase 2. Recall of Power and Price Re-Negotiation (1971-1988): In the early 1970s, the NL government expressed dissatisfaction over the contract leading to the second conflict. In this period, there were important changes in DMs and options.
- Phase 3. Lower Churchill Project (2003-2011): Although the circumstances of the Lower Churchill Project are similar to the Upper Churchill Project, the development and contracts are different. DMs and options were similar, but a third party inter-venuer played a more important role, changing the outcome. Moreover, the experience with the old contract improved the strategies of the players.
- Phase 4. The automatic renewal (2016):(Feehan, 2011) This is expected to take place in the near future (Feehan and Baker, 2007). A model should consider a number of

possible scenarios and whether third party intervention could prevent an escalation of the conflict.

3.3.1 The First Conflict: Contract Negotiations

Before signing the letter of intent

During the early phases of contract negotiations, almost everything was possible. The DMs discovered new opportunities with the many options on the table, opportunities that were reduced in the second phase. DMs in this stage were:

1. Brinco and Partners: Brinco led the first phase of negotiations when it proposed the project to Hydro-Québec and financing institutions. The Brinco partners were represented in CFLCo and its shareholder Shawinigan Engineering. Brinco, CFLCo, and Shawinigan Engineering had similar options and acted as one player in the negotiation stage. The NL government had some contact with Brinco and QC government during the negotiations ([Feehan, 2011](#)) but did not play a substantial role ([Feehan and Baker, 2007](#)). The options available to Brinco and its partners include:
 - Transmit electricity via QC to buyers elsewhere,
 - Transmit electricity via the Maritimes route to buyers elsewhere,
 - Sell power to QC, or
 - Cancel the development.
2. Hydro-Québec: This privately owned company was pleased with the opportunity to take part in the Upper Churchill Project. It had the option of accepting proposals or delaying until more lucrative terms were reached.

Table 3.1: Decision Makers and Options in the Contract Negotiations before 1966

DMs	Options
Brinco and Partners in CFLCo	QC route
	Maritimes route
	Sell power to QC
	Cancel the development
Hydro-Québec	Sign
	Delay
Investors	Finance

3. Financing Institutions: They would finance or not depending on the deal. These institutions wanted an economically viable project that would ensure them an acceptable return on their investment.

See Table 3.1 for a summary of DMs and options.

After signing the letter of intent

Important changes in the players and options shaped this phase preceding the signing of a definitive contract. QC nationalized its hydroelectric companies, including Hydro-Québec and Shawinigan Engineering. This change put the QC government on both sides of the table: with Brinco as a partner in CFLCo replacing Shawinigan Engineering, and as a buyer on the side of Hydro-Québec. Inside Brinco, this change was perceived to create a conflict of interest, which was partially remediated by inviting the NL government to purchase a small share in CFLCo. However, QC was able to see the perspective of the seller as well as the buyer, giving it a great advantage in the negotiations. At this stage, it became clear that transmitting the power via the Maritimes route was not welcomed by the financing institutions, and QC rejected the proposal to use its own route to transmit

Table 3.2: Option Form for Contract Negotiations after 1966

DMs	Options
Brinco and Partners in CFLCo	Sell power to QC Cancel the development
Hydro-Québec	Sign Delay
Investors	Finance

energy owned by NL to other buyers. Brinco and its partners realized that their options had shrunk to only two: either sell the generated power to QC, or cancel the development. Brinco could not afford to cancel. CFLCo started construction immediately after signing the letter of intent and came under pressure to sign the final agreement with QC in order to continue receiving money from investors. QC used this situation to its advantage and delayed signing the final deal for three years, until Brinco, represented by CFLCo was prepared to accept any terms in order to expedite the process. At this time, the automatic renewal clause came into the deal as an addition to the extended duration. See Table 3.2 for a summary of players and options.

Preferences

Brinco and its partners preferred to have cheap access to an open market. This is possible by transmitting power through QC and exporting energy to the highest bidders, potentially, in the US. Brinco also did not want the project to be called off since it was in financial distress and needed this project to continue. The Maritimes route is favoured if and only if investors agree to finance it and QC refuses to permit the use of its transmission lines. These preferences changed after the signing of the letter of intent when it became clear to Brinco that the only available option other than calling off the development was to

sell power to QC. QC, on the other hand, saw an attractive opportunity in the deal only if power was sold to it. However, Brinco choosing the Maritimes route is less preferred than cancelling the development to Hydro-Québec. The investors and financial institutions prefer to finance the project, but only when an attractive deal is in place. Their view of an attractive and financially viable deal requires that either Brinco reaches an agreement with Hydro-Québec to transmit electricity via QC transmission lines, or that it sells the power to QC.

3.3.2 The Second Conflict: Recall of Power and Price Re-Negotiation

After the contract was settled, NL quickly expressed dissatisfaction and claimed the deal was unfair and unethical. Its dissatisfaction spread through media to the public. Two challenges ruled on by the Supreme Court of Canada both affirmed that the contract was valid ([The Supreme Court of Canada, 1988a,b](#)). These attempts introduced the Supreme Court as a player in the conflict. Other players included the QC government and Hydro-Québec, NL government, and CFLCo. Table 3.3 lists the players, and their options are presented in what is called option form.

3.3.3 The Third Conflict: The Lower Churchill Falls Project

Although the Lower Churchill Falls project may seem similar to the first contract negotiations, an important third party intervention changed the conflict. The Federal Government of Canada intervened and backed loans to the NL government to secure finances for the Maritimes route, which in the past had been considered uneconomical by financing institutions. See Figure 3.1 for the Maritimes Route. This game-changer greatly affected

Table 3.3: Decision Makers and Options for Recall of Power and Price Re-Negotiation—

DMs	Options
Gov. of NL	1-Appeal to the Canadian Public (Media) 2-Call on the federal government for intervention (Intervention) 3-Appeal to the Supreme Court of Canada (Appeal) 4-Invoke the water rights reversion act (Water Act)
Gov. of QC	1-Accept renegotiation of the contract (Accept) 2-Appeal to the Supreme Court of Canada against the water reversion act (Appeal)
Supreme Court of Canada	1-Modify the contract (Modify) 2-Accept the water rights reversion act (Accept)

the outcome of the third conflict. The new option provided the NL government with a stronger position when negotiating the terms with any potential buyer of energy including QC. Furthermore, having the Maritimes transmission line in place when the automatic renewal is due may motivate NL to threaten to break the deal with QC. The players and their options are listed in Table 3.4.

3.3.4 The Fourth Conflict: Automatic Renewal Clause

In 2016, it is likely that the NL government will invite QC to sit at the negotiation table again to reconsider the automatic renewal clause (Feehan and Baker, 2007). This attempt will likely take a similar path to the Supreme Court of Canada. The renewal clause was not discussed at the time of the second conflict (Feehan and Baker, 2007). Hence, the conflict probably will have three main players: the NL government, the QC government, and the Supreme Court of Canada. Another scenario is also possible. The federal government could intervene as it did in the third conflict, which may have an impact on the course of the conflict. The possible options for each potential player are shown in Table 3.5.

Table 3.4: Decision Makers and Options for the Lower Churchill Falls Project

Players	Options
Gov. of NL	QC route Maritimes route Sell power to QC Cancel the development
Gov. of QC	Sign Delay
Investors	Finance
Federal Government	Back investment

Table 3.5: Decision Makers and Options for Future Dispute (2016) on Automatic Renewal Clause of Upper Churchill Falls

Players	Options
Gov. of NL	1-Appeal to the Canadian Public (Media) 2-Call on the federal government for intervention (Intervention) 3-Appeal to the Supreme Court of Canada (Appeal)
Gov. of QC	1-Accept breaking of the contract 2-Modify price of renewal period
Supreme Court of Canada	1-Break the contract 2-Modify the contract
Federal Government	1-Insist on a resolution 2-Subsidize NL's losses 3-Subsidize QC's losses

3.4 Conflict Analysis: Contract Negotiations (1963-1969)

The Great Canadian Hydroelectric Power Conflict is indeed a very complex ongoing conflict that evolved over a long time. For the scope of this Chapter, only the Contract Negotiations are analyzed. The two phases of Contract Negotiations will be analyzed separately here. The differences between the two contract-negotiation phases that took place during the conflict are shown in Table 3.6.

Table 3.6: Players and Options of the Two Phases of Contract Negotiations

Before 1966	After 1966
DMs & Options	DMs & Options
<ol style="list-style-type: none"> 1. Brinco, CFLCo, Shawinigan Eng. <ul style="list-style-type: none"> • Maritimes Route • Transmit via QC • Sell to QC • Call off the development 2. Hydro-Québec, QC Gov <ul style="list-style-type: none"> • Sign • Delay 3. Investors <ul style="list-style-type: none"> • Finance 	<ol style="list-style-type: none"> 1. Brinco and QC Gov <ul style="list-style-type: none"> • Sell to QC • Call off the development 2. QC Gov, Hydro-Québec, and (Shawinigan Eng.) <ul style="list-style-type: none"> • Sign • Delay 3. Investors <ul style="list-style-type: none"> • Finance

Table 3.7: Contract Negotiations before 1966

DMs	Options	Outcomes											
	States	1	2	3	4	5	6	7	8	9	10	11	12
Brinco	TVQC	Y	N	N	Y	N	N	Y	N	N	Y	N	N
	Maritimes	N	N	Y	N	N	N	N	N	Y	N	N	N
	STQC	N	Y	N	N	Y	N	N	Y	N	N	Y	N
	Call off	N	N	N	N	N	Y	N	N	N	N	N	Y
	Preference Ranking	7 > 8 > 9 > 11 > 10 > 12 > 6 > 1 ~ 2 ~ 3 ~ 4 ~ 5											
Hydro-Québec	Sign	Y	Y	N	N	N	N	Y	Y	N	N	N	N
	Delay	N	N	Y	Y	Y	Y	N	N	Y	Y	Y	Y
	Preference Ranking	8 > 2 > 3 ~ 4 > 6 > 5 ~ 11 > 10 ~ 12 > 1 ~ 7 > 9											
Investors	Finance	N	N	N	N	N	N	Y	Y	Y	Y	Y	Y
	Preference Ranking	7 ~ 8 > 1 ~ 2 > 3 ~ 4 ~ 5 ~ 6 ~ 10 > 9 ~ 11 > 12											
Note	TVQC	Transmit via QC											
	Maritimes	Maritimes Route											
	STQC	Sell to QC											

3.4.1 Before Signing the Letter of Intent (1963-1966)

The negotiations prior to the signing of the letter of intent are presented in Table 3.7. Only logically infeasible states were removed from the set of possible states in order to avoid false equilibria. The conflict was analyzed using the GMCR II decision support system (Hipel et al., 1997) and resulted in the equilibria shown in Table 3.8.

During the negotiations there were four equilibria at states 7, 8, 9, and 6. The equilibrium states show that all options available to Brinco are consistent with possible equilibria. As the negotiations move to the signing of the letter of intent, Brinco realizes that its options have shrunk to only two, leading to the second phase of the negotiations.

Table 3.8: Equilibria States for Contract Negotiations before 1966

Brinco				
TVQC	Y	N	N	N
Maritimes	N	N	Y	N
STQC	N	Y	N	N
Call off	N	N	N	Y
Hydro-Québec				
Sign	Y	Y	N	N
Delay	N	N	Y	Y
Investors				
Finance	Y	Y	Y	N
State Number	7	8	9	6
Note				
TVQC	Transmit via QC			
Maritimes	Maritimes Route			
STQC	Sell to QC			

3.4.2 From the Letter of Intent to the Final Contract (1966-1969)

Phase 2 of contract negotiations was reached only after Brinco realized its real options. The project could be developed only by reaching an agreement to sell Hydro-Québec the energy. Otherwise, Brinco will be forced to cancel the development, which it greatly prefers to avoid. See Table 3.9 for the graph model options and possible outcomes. Movement from the status quo state to the only equilibrium is shown in Table 3.10, which indicates that, in the intermediate stage, Hydro-Québec delayed signing the deal until it met its terms, taking advantage of QC's knowledge of Brinco's weak financial position.

Table 3.9: Contract Negotiations after 1966

Players	Options	Outcomes			
	States	1	2	3	4
Brinco	Sell	Y	Y	N	Y
	Call off	N	N	Y	N
	Preference Ranking	4 \succ 1 \succ 2 \succ 3			
Hydro-Québec	Sign	Y	N	N	Y
	Delay	N	Y	Y	N
	Preference Ranking	4 \succ 1 \succ 2 \succ 3			
Investors	Finance	N	N	N	Y
	Preference Ranking	4 \succ 1 \sim 2 \sim 3			

Table 3.10: How Negotiations Moved toward Equilibrium (Y: Yes, N: No)

DMs and Options	Status Quo	Transitional State		Equilibrium
<i>Brinco</i>				
Sell	Y		Y	Y
Call off	N		N	N
<i>Hydro-Québec</i>				
Sign	N	\implies	Y	Y
Delay	Y	\implies	N	Y
<i>Investors</i>				
Finance	N		N	\implies Y

3.5 Sensitivity Analysis: Contract Negotiations

The objective of sensitivity analysis is to ascertain whether the outcome of the analysis was robust or susceptible to changes based on a simple variation of the parameters of the conflict, which in principle includes players, options, or preferences. Sensitivity analysis is often called “what-if” analysis. Reasonable scenarios to explore include “what if Brinco were not in financial despair”, and “what if the NL government guaranteed financing of any option that Brinco decided to take”. Others include “what if the Federal Government

had intervened to change the preferences of Hydro-Québec, or had introduced legislation covering inter-provincial power transmission”. It is obvious that other possible scenarios could have resulted in different outcomes compared what actually took place.

3.5.1 What If Brinco were Financially Secure?

Assume that Brinco is financially secure, perhaps, because the NL government backed its loans, or investors saw a real opportunity, poured money into the company, and trusted its moves. Brinco would have had a stronger negotiating position, and more freedom in making its choices. The graph model would cover the new Negotiation Conflict in Table 3.11.

Table 3.12 shows how new equilibria would evolve. Beginning in state 4, Brinco will approach Hydro-Québec to secure a deal to transmit power via Hydro-Québec transmission lines to buyers elsewhere. Hydro-Québec would refuse, and then Brinco will move toward its second preference, which is to build the Maritimes transmission line. This is a Nash equilibrium for Brinco, which Hydro-Québec cannot affect on its own. The result is state 3, a new equilibrium that differs from what took place in the original conflict. In fact, this development reflects the situation in 2011 with the Lower Churchill Falls development, when NL was able to secure financing from the Federal Government that backed its loans, despite objections from QC ([CBC News, 2011](#)).

3.6 Third Party Intervention: Contract Negotiations

Could this conflict have been resolved by third party intervention? This section will explore how the Federal Government could play a positive role in obtaining a resolution fair to both

Table 3.11: Contract Negotiations with Brinco in Good Finances

Players	Options States	Outcomes					
		1	2	3	4	5	6
Brinco	TVQC	Y	N	N	Y	N	N
	Maritimes	N	N	Y	N	N	N
	STQC	N	Y	N	N	Y	N
	Call off	N	N	N	N	N	Y
Preference Ranking		1 \succ 3 \succ 2 \succ 4 \sim 5 \sim 6					
Hydro-Québec	Sign	Y	Y	N	N	N	N
	Delay	N	N	Y	Y	Y	Y
	Preference Ranking	5 \succ 2 \succ 3 \sim 4 \sim 6 \succ 1					
Note	TVQC	Transmit via QC					
	Maritimes	Maritimes Route					
	STQC	Sell to QC					

Table 3.12: Moving toward Equilibria when Brinco is in Good Finances

Players & Options		
Brinco		
TVQC	Y	\implies N
Maritimes	N	\implies Y
STQC	N	\implies N
Call off	N	\implies N
Hydro-Québec		
Sign	N	\implies N
Delay	Y	\implies Y
State Number	4	\implies 3
Note		
TVQC	Transmit via QC	
Maritimes	Maritimes Route	
STQC	Sell to QC	

parties, perhaps even during the negotiation of the initial contract. Using value-focused thinking ([Keeney, 1992](#)), the Federal Government could help NL and QC reach a resolution they both prefer.

Valuing Canada as one nation and protecting the interest of the general public is part of the Federal Government's role. Taking this value into consideration, the Federal Government would prefer a resolution in which free access to markets is granted to every province. Moreover, the Federal Government values cooperative projects that enhance intra-provincial ties and strengthen local economic growth that benefits all provinces.

Such an outcome could have been achieved if the Federal Government had mediated to bridge the gap between the two provinces and helped them reach an agreement acceptable in the eyes of both Québeckers and the Newfoundlanders and Labradorians. In order that every party realizes benefits from the contract, NL must earn money selling its clean energy to QC, which QC can sell as a clean energy source to American customers. Moreover, letting NL sell excess energy to other buyers would bring earnings from the transmission charges to support upgrading and further developing QC's transmission lines.

3.7 Lessons Learned, Insights, and Conclusions

Analysis shows that some causes of the Great Canadian Hydroelectric Power Conflict still exist, but can be mitigated through regulations that empower the energy sector. For example, regulating risk exposure ([Willems and Corte, 2008](#)) could incentivize investments to fund energy projects, which would reduce the need for extremely long-term contracts.

3.7.1 Lessons Learned and Insights

The following points summarize the lessons learned from the contract negotiations events while drawing some insights:

- As a board member and a significant shareholder of Brinco, QC was privy to important information concerning Brinco. This exposure weakened Brinco's position in the negotiations,
- The delay in signing the deal forced Brinco to accept all terms and conditions,
- Uncertainty played against Brinco when investors refused to fund anything other than selling or transmitting power via QC,
- While the contract price was legitimate, as later ruled by the Supreme Court of Canada, the duration, and the automatic renewal clause are questionable,
- The 99 years lease of water and land rights from NL government to Brinco should have contained conditions in regard to income generation to avoid lousy contracts,
- Brinco should have pushed for the option of transmitting power through QC to other buyers, using legal options based on Canadian law,
- There was no third party intervener, which could have helped to reach a more equitable solution.

3.7.2 Conclusions

In conclusion, it seems that the hydroelectric power conflict examined in this chapter is likely to continue unless an intervener enters the game and works out a resolution that

satisfies both parties, based, for example, on a value-focused thinking (Keeney, 1992). Intervention is urgently needed because plans for the development of the expensive Maritimes transmission line, which includes two subsea cables, are ongoing. These resources could be better-directed toward expanding and maintaining the current QC transmission line. Finally, policies and regulations should be introduced or amended to protect the public interest in long-term contracts, such as the one between Hydro-Québec and CFLCo. Recommended further research includes the analysis of the future conflict in 2016 as well as carrying out uncertainty analysis of preferences and options.

3.8 Chapter Summary

The contract negotiation that led to the 1969 agreement between NL, and Quebec, is systemically analyzed within the framework of Graph Model for Conflict Resolution. The Great Canadian Hydroelectric Power Conflict has been ongoing since 1963 and shows no signs of ending. In this dispute, the Province of Quebec has the right to buy almost all of the power generated from the Upper Churchill Falls, which is located in the Labrador territory in NL, at a very low price. Originally, the contract was signed by Churchill Falls Labrador Corporation to secure finances for the Upper Churchill Falls development. The unpopularity of the contract led to several unsuccessful attempts by the NL Government to escape its provisions. NL is currently negotiating to develop the Lower Churchill Project and seeking to avoid the mistakes of the first contract. Furthermore, the automatic renewal clause of the original contract is expected to cause another round of conflict in 2016. The analysis shows that, given the circumstances in which the agreement was signed, the outcome was almost inevitable. A third party intervener rule could have remediated the damage caused by the conflict.

Chapter 4

Characterization of a Conflict

This chapter is largely based on two publications by [Matbouli et al. \(2013a, 2014d\)](#), which provide suggestions on how to capture key information of a real life conflict in order to use it in a model. It also highlights important features that connect several conflicts to one. In addition, an enhanced representation of the Graph Model for Conflict Resolution (GMCR) is proposed to show decision makers' preferences on the graph.

4.1 Introduction

Characterization of conflict modes and parameters in order to facilitate the recognition of an original conflict is proposed. Long-term conflicts that tend to evolve over time take place in several rounds, and in order to connect the rounds and attribute them to one conflict, characterization of a conflict is introduced. In modes of a conflict, the activity cycle in which a conflict takes place is presented. Parameters of conflicts are identified in terms of decision makers, objectives, options, and status quo. Then, using an enhanced

graph model, a new way of representing preferences on the graph is outlined. Finally, an illustrative example is given for the Great Canadian Hydroelectric Power conflict.

4.2 Characterization Categories

A review of conflict theory in literature is presented in Section 2.1. Characterization of conflicts is divided into three categories: modes of a conflict, macro versus micro conflict, and parameters of a conflict. Each category is explained in the following sections.

4.2.1 Modes of a conflict

Modes of conflicts describe the activity conditions of a conflict. In this section, three conflict modes are defined: incipient, active, and dormant. The recognition that a conflict passes through stages facilitates its analysis, even before it occurs. In some situations, conflict conditions exist even though there are no moves. Figure 4.1 indicates that a conflict starts in the incipient mode; then, when moves start, it becomes active. After a set of moves and countermoves, the conflict may reach an equilibrium. If this equilibrium is sustainable, then the conflict is considered resolved. However, if this equilibrium is temporary, the conflict becomes dormant for a period of time before a new move is initiated, which causes the conflict to become active again.

Incipient Conflict

An incipient conflict is a conflict that has not yet become active, meaning no moves have taken place. This happens when conflicting goals exist, or scarcities of shared resources are predicted. For instance, where a water body is shared among a number of beneficiaries,

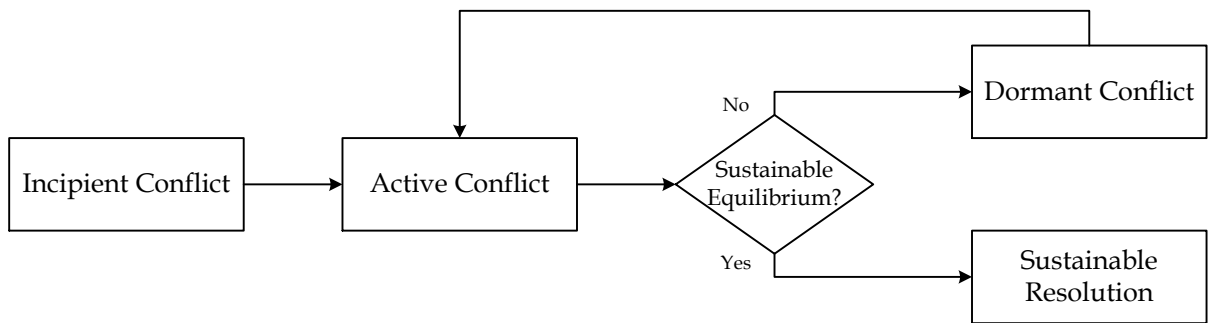

Figure 4.1: Modes of Conflict

water conflicts can be expected when a DM pollutes the environment and other affected DMs can be expected to react once the pollution is discovered and associated risks are understood. During an incipient mode, goal realization takes place, options are discovered, and interested actors prepare to intervene.

Active Conflict

A conflict is considered active as soon as the first move is made, when the status quo is challenged. Moves and countermoves take place during an active conflict until an equilibrium is reached. The first move, which challenges the status quo, is an important component of this stage, because it indicates the baseline motivation of the interested DM. Therefore, if a future round of the conflict results in a situation that is no more preferred to the initiator, the conflict can be expected to continue.

Dormant Conflict

After a conflict reaches a temporary equilibrium, it is considered dormant until a move challenges the equilibrium. The difference between an incipient and dormant conflict is

that a conflict in incipient mode has not yet started, while a dormant mode occurs between rounds of a conflict that has already started.

4.2.2 Macro versus Micro Conflict

Another important aspect of conflict characterization is the level at which the intended conflict is investigated. For example, the Second World War took place between the two main parties: the Allies and the Axis. But, an analyst may be interested in a specific confrontation between two or more forces, in a more specific time or place. The level at which a conflict is to be analyzed should be defined clearly, whether it is the highest macro level of the conflict or a micro conflict where small details matter. For the purpose of conflict evolution, the macro level of a conflict is more important than the micro level. An analyst may be interested in the micro level of a conflict in order to study tactical responses of DMs in a conflict, but for resolution purposes, the macro level of the conflict would better illustrate the main options and available moves leading to a resolution.

4.2.3 Parameters of a Conflict

A conflict involves two or more DMs. Each DM can select options to enhance or preserve his or her interest. There are a number of parameters that characterize a specific conflict.

Decision Makers (DMs)

DMs represent an important parameter of conflicts, which happen as a result of DM interactions. The features of the DMs that characterize a conflict include:

1. *Level of interest or involvement of DM*: DMs have various degrees of involvement in a conflict. Some DMs are more directly involved and have a more vital interest in the outcomes of the conflict. Any DM with an interest at stake is considered a DM in the conflict. Other DMs, such as third-party interveners (Lewicki et al., 1992; Charness et al., 2008), may play a significant role in shaping the outcome of a conflict without necessarily being directly affected by the results. A third-party intervener may be disinterested in a conflict but act to resolve the conflict because of its designated role. For example, a federal government is responsible to intervene in conflicts among local governments. Another example is when a third-party intervener's interest is to avoid the consequences of escalation between neighbouring countries.
2. *First move*: Insights can be gained by identifying the DM who makes the first move away from an incipient conflict. This DM is motivated to start the conflict, which presumably will not be resolved until his or her motivation to change the situation is reduced. The first move implies that if the resulting equilibrium is equally preferred to the status quo that was initially challenged, it is unsustainable. Also, the first move provides baseline information for a conflict by identifying a proactive DM with enough interest to engage in a conflict.
3. *Proactive (Initiator) and reactive*: Since conflicts are analyzed in terms of moves and countermoves, it is logical to think of DMs as being proactive and reactive. A proactive DM takes an option that is independent of others. A countermove is a reaction, and the responding DM is reactive.
4. *Preferences of a DM*: A DM starts a conflict because he or she prefers a different state. The preferences of a DM may or may not be changed if the conflict evolves. Changes in preferences could be caused by changes in attitudes and emotions, which

may change from one conflict round to another. Attitudes ([Inohara and Hipel, 2008b](#); [Bernath Walker et al., 2009](#)) and emotions ([Obeidi et al., 2005](#)) have an impact on DM perceptions, which affect preferences.

5. *Change in DMs*: DMs can be a unique feature of a conflict, and usually a change in DMs means a different conflict. However, there are some situations where DMs may change, yet the conflict remains the same, such as a third-party intervention ([Lewicki et al., 1992](#); [Charness et al., 2008](#)) which was absent in the first round and exists in the second. Also, a DM may act on behalf of other interested individuals, for instance when one government is replaced by another that is more attuned to the interests of the people.

For conflicts evolving over time, some of the characteristics mentioned above for DMs may or may not change. DMs are the centre of any conflict. The stability and resolution of a conflict occur when a state that is stable for all DMs is reached. Changes over time in DMs' positions are uncertain. However, characterizing a DM could provide insights about future positions.

Objectives

Objectives are unique characteristics of a conflict. The ultimate objective of DMs in a conflict is to maximize their interest share or minimize the damage to their interest. The area of specific interest of a conflict is considered a distinguishing feature. For instance, a conflict over shares of a specific water body is defined by that water body's name. In future, if new rounds of conflict evolve in regard to the same issue, they can be attributed to the initial conflict.

Options

Options are the part of conflict resolution where DMs actually make decisions. These decisions are based on alternatives available for DMs. Considering short and far sight, DMs take the options that put them in positions they prefer more than existing conditions, whether that be the status quo or an intermediate state in the conflict. Also, options represent the steps that a DM takes in order to achieve his or her ultimate goal. Rounds of conflicts evolve when new options become available that did not exist before, or when attitudes change toward tolerating more aggressive options.

Status Quo

The status quo is a unique feature of a conflict. It could provide the proof that a specific round of a conflict is a continuation of the first round. This can be checked by looking at the most recent equilibrium; if the new round starts where the previous conflict ended, it means these two conflicts are connected (see Figures 4.2 and 4.3). Furthermore, the status quo gives an idea about the situation of a particular issue that is to be challenged by DMs. Therefore, a new status quo describing the conditions that existed before a new round of a conflict started provides valuable information about dissatisfaction of DMs.

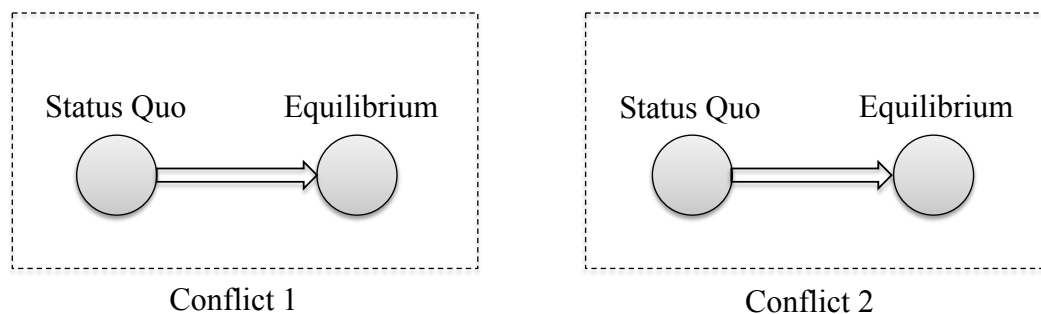

Figure 4.2: Different Conflicts

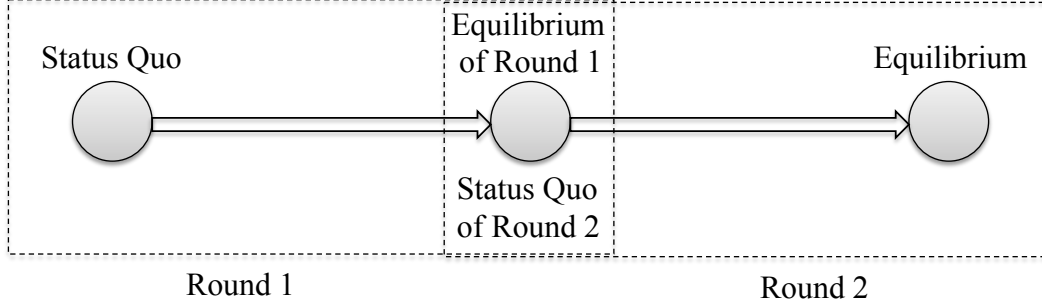

Figure 4.3: Connected Rounds of the Same Evolving Conflict

4.3 Representing Conflict Parameters in the Graph Model

There are a number of ways to model conflicts, including the normal form, the extensive form, the option form, and the graph model. Each modelling strategy conveys a particular amount of information based on its illustrative capacity. The normal form, for instance, is compact, easy to draw, and simple to read. However, it can only be used for small conflicts where the number of DMs is limited to two or three. There is also a limited amount of information conveyed through the extensive form. GMCR, which can use the option form for notation, is the most comprehensive modelling approach for conflicts. It presents moves and countermoves only when they exist. GMCR can account for moves that are reversible or irreversible and common, and preferences that are either transitive or intransitive.

4.3.1 The Graph Model for Conflict Resolution

As noted in Section 2.3, for each DM, the Graph Model for Conflict Resolution consists of three main elements: feasible states, unilateral moves, and preferences. The graph model for DM_i is $G_i = (S, A_i, \{\succ_i, \sim_i\})$ where G_i is the DM's i graph, S is the set of feasible

states, A_i is the set of unilateral moves available for DM_i such that $A_i \subseteq S \times S$, and $\{\succ_i, \sim_i\}$ represents DM_i 's preference relation; for any $s, q \in S$, $s \succ_i q$ means state s is more preferred than state q , and $s \sim_i q$ means state s is indifferent to state q for DM_i .

Each graph consists of a collection of directed graphs $D_{i \in N} = (S, A_{i \in N})$. These directed graphs consist of nodes and arcs. Each node represents a state $s \in S$, and each arc A_i represents a unilateral move available to DM_i . The list of reachable states by DM_i is denoted by R_i and is defined by:

$$R_i(s, q) = \begin{cases} 1 & \text{if } DM_i \text{ can move unilaterally from state } s \text{ to } q \\ 0 & \text{otherwise} \end{cases}$$

Based on the reachable list of a DM, each arc is drawn in a solid line and the direction indicating the move end point. An example of the graph model for Brinco is given in Section 4.4.3

4.3.2 The Preference Graph Model

Changes are proposed to the original definition of graph model to introduce the preference graph model. The elements of the Preference Graph Model remain similar to the original graph. However, the oriented arcs no longer represent unilateral moves, but rather, unilateral improvements. Hence, desired but not possible moves are represented by dashed oriented arcs to differentiate between an available and a desired but not possible unilateral move. Now, the graph model for DM_i becomes $G_i = (S, M_i, V_i, U_i)$ where G_i is the DM's i graph, S is the set of feasible states, M_i is the set of reversible unilateral improvements available for DM_i such that $M_i \subseteq S \times S$, V_i is the set of irreversible unilateral improvements available for DM_i such that $V_i \subseteq S \times S$ and U_i is the set of desired but not available

moves such that $U_i \subseteq S \times S$, in symbols, $U_i = \{(s_1, s_2) \in S \times S : (s_1, s_2) \notin M_i \cup V_i \text{ and } s_2 \succ_i s_1\}$.

There are a number of directed graphs different than the one in the original graph model. In the original graph model arcs represented unilateral moves available to a DM without regard to the DM's preference of the states. Now, because the new preference graph model focuses on representing the preferences using different shaped arcs, the new reachable list is denoted by R_i^* and defined as:

$$R_i^*(s, q) = \begin{cases} M_i & \text{if } R_i(s, q) = R_i(q, s) = 1 \text{ and } q \succ_i s \\ V_i & \text{if } R_i(s, q) = 1 \neq R_i(q, s) \text{ and } q \succ_i s \\ U_i & \text{if } R_i(s, q) = R_i(q, s) = 0 \text{ and } q \succ_i s \\ 0 & \text{otherwise} \end{cases}$$

The Preference Graph Model can provide insights into stability analysis of individual DMs. A comparison between the original graph model and the preference graph model is given in Section 4.4.3. For example, in Figure 4.6 it can be inferred that Brinco is Nash stable at states 7 and 9, because there are no unilateral improvements from these states. Such advantage will simplify the analysis of conflicts using the Preference Graph Model for Conflict Resolution.

4.4 Case Study: the Great Canadian Hydroelectric Power Conflict

In this section, the proposed characterization categories of a conflict are applied to the Great Canadian Hydroelectric Power conflict (Feehan and Baker, 2007; Feehan, 2011; Mat-

[bouli et al., 2012b, 2014b](#)), followed by an illustrative example of using the preference graph model. In the characterization of this conflict, modes of the conflict and parameters are discussed.

4.4.1 Modes of the Great Canadian Hydroelectric Power Conflict

1. *Incipient conflict*: In the period from 1958 to 1963, Brinco was established and the letter of intent regarding the Churchill Falls project was signed ([Feehan and Baker, 2007](#)).
2. *Active conflict*: The conflict has seen activity over several periods. The first is marked by the negotiations between Brinco and Québec (QC), which ended in the contract signed in 1969. The second active period of the conflict started in 1971 when Newfoundland and Labrador (NL) expressed dissatisfaction over the agreement until its challenge was ended by the rulings of The Supreme Court of Canada ([The Supreme Court of Canada, 1988a,b](#)). The third round of active conflict started in 2003 when NL proposed to develop the Lower Churchill Falls project. If the third round ends, a fourth round of active conflict is expected to take place when the automatic renewal clause comes into force in 2016 ([Feehan and Baker, 2007](#)).
3. *Dormant conflict*: Between active conflict rounds there is a dormancy period. The shortest was after the deal was signed. The longer the dormancy period, the less intense the conflict, especially when the active rounds do not result in a change in the equilibrium.

4.4.2 Parameters of the Great Canadian Hydroelectric Power Conflict

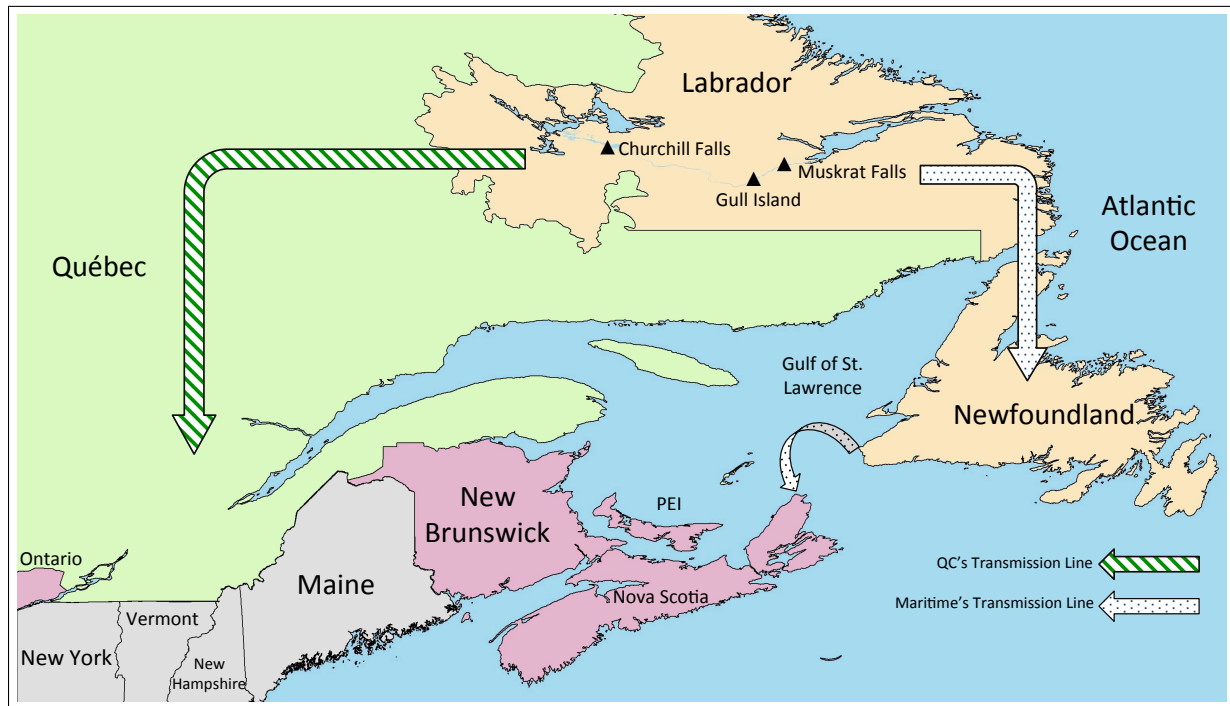

Figure 4.4: Churchill Falls Location and Transmission Routes

Decision Makers

- Number of DMs: this conflict has many DMs, summarized in Table 4.1 (Matbouli et al., 2014b) and described as follows (Matbouli et al., 2014b):
 1. The Government of Newfoundland and Labrador (NL): NL is the owner of the Churchill Falls site (CF). NL wants to encourage investment to develop its own economy. The CF is located far from the NL capital and populous areas.

2. The Government of Québec (QC): The NL-QC border is adjacent to the Churchill Falls site. QC has a transmission line nearby, and a large hydroelectric power capacity that enables it to export energy to neighbouring provinces and to the United States.
 3. The British Newfoundland Development Corporation (Brinco): Brinco was established by NL with the help of British industrialists and bankers to develop industrial opportunities in NL.
 4. Churchill Falls (Labrador) Corporation (CFLCo): CFLCO was established by Brinco to exploit the hydropower potential of CF. Brinco invited Shawinigan Engineering to take a 20% stake in CFLCo.
 5. Hydro-Québec (HQ): Hydro-Québec is the hydroelectric utility in QC, in charge of producing and transmitting power in the province. It owns the transmission line that CFLCo could use.
 6. Shawinigan Engineering: Shawinigan was a privately owned engineering consultancy, which was later nationalized by QC, with vast experience in hydropower. It has a 20% stake in CFLCo.
 7. Financing Institutions: A group of banks and financial institutions were approached to finance the CF project.
 8. The Canadian Federal Government.
 9. The Supreme Court of Canada.
- Types of DMs: NL, Brinco, and CFLCo can be treated together because they represent a hierarchy of power and have the same interests. These DMs are directly impacted by the result of the conflict, and can be considered to be key players. Brinco led the other DMs in the negotiations. Similarly, QC and Hydro-Québec are

Table 4.1: Decision Makers, Options, and Preferences of the Great Canadian Hydroelectric Power Conflict (Matbouli et al., 2012b, 2014b)

DMs	Options	Outcomes											
		1	2	3	4	5	6	7	8	9	10	11	12
Brinco	TVQC	Y	N	N	Y	N	N	Y	N	N	Y	N	N
	TVM	N	N	Y	N	N	N	N	N	Y	N	N	N
	STQC	N	Y	N	N	Y	N	N	Y	N	N	Y	N
	Call off	N	N	N	N	N	Y	N	N	N	N	N	Y
Preference Ranking		7 > 8 > 9 > 11 > 10 > 12 > 6 > 1 ~ 2 ~ 3 ~ 4 ~ 5											
QC	Sign	Y	Y	N	N	N	N	Y	Y	N	N	N	N
	Delay	N	N	Y	Y	Y	Y	N	N	Y	Y	Y	Y
Preference Ranking		8 > 2 > 3 ~ 4 > 6 > 5 ~ 11 > 10 ~ 12 > 1 ~ 7 > 9											
Investors	Finance	N	N	N	N	N	N	Y	Y	Y	Y	Y	Y
Preference Ranking		7 ~ 8 > 1 ~ 2 > 3 ~ 4 ~ 5 ~ 6 ~ 10 > 9 ~ 11 > 12											
Note	TVQC	Transmit via Québec											
	TVM	Transmit via Maritime Route											
	STQC	Sell to Québec											

also considered to be key DMs because the outcome of the conflict directly impacts their interests. The financial institutions, on the other hand, are considered as a support DM, because their role can facilitate the outcome of the conflict, but they do not have a major interest in it. Finally, the Federal Government and the Supreme Court of Canada are both considered third-party interveners who have the power to change the outcome of the conflict.

- First move: Brinco and its partners (NL and CFLCo) made the first move in the conflict. They were motivated enough to deviate from the status quo. Any outcome

that is not more preferred than the status quo is not acceptable to them.

- Proactive and reactive: Brinco and its partners were proactive in most instances. They initiated moves to which QC responded with a countermove and/or an agreement.
- Preferences: The preferences of the DMs in the first round are ranked in Table 4.1 (Matbouli et al., 2012b, 2014b).
- Changes in DMs: there have been a number of important changes in DMs, summarized as follows:
 1. QC nationalized all Québec-based hydroelectric companies including Hydro-Québec and Shawinigan Engineering during the negotiations.
 2. NL purchased Brinco's share in CFLCo shortly after the deal was signed with QC. With this move, NL tries to gain control of the decision making role.
 3. In 2012, the federal government announced that it will guarantee loans for NL to finance the Lower Churchill Falls project.

Objectives

The objective of the DM who made the first move from the status quo, namely, Brinco and its partners, is to maximize the exploitation of the Churchill Falls hydropower potential. For Hydro-Québec, the objective is to minimize competition to its market and increase its own share of the hydroelectric power market. The objectives of both DMs seem to be incompatible. An increase in market share for Brinco will result in a decrease for Hydro-Québec.

Options

When Brinco and its partners considered developing the Churchill Falls hydropower potentials, they assumed three options: transfer produced power via QC, transfer it via the Maritimes (see Figure 4.4), or cancel the entire project. When QC was approached, it had two options: accept immediately or delay signing the contract. Options are summarized in Table 4.1 (Matbouli et al., 2012b). Please note that (Y): Yes, and (N): No.

Status Quo

The Great Canadian Hydroelectric Power Conflict has taken place in four rounds. The status quo of each round is described as follows:

1. In 1963, at the first status quo, Brinco approached Hydro-Québec and started negotiations in regard to the exploitation of Churchill Falls hydropower potential.
2. The second status quo is the equilibrium after the negotiations resulted in signing a definitive contract in 1969. The second round of the conflict took place to challenge this status quo.
3. The third status quo, in 1988, was the equilibrium of the second round, which took place as the Supreme Court of Canada ruled on the second round.
4. The fourth status quo for a future round of the conflict is not yet defined, pending the outcome of the current negotiations of the Lower Churchill Falls project.

4.4.3 Example of the Graph Model versus the Preference Graph Model for Brinco

Original Graph Model for Brinco

For example, consider the graph model for Brinco given in Figure 4.5. There are twelve states $S = \{1, 2, 3, 4, 5, 6, 7, 8, 9, 10, 11, 12\}$ and the preference relation for Brinco is:

$$7 \succ 8 \succ 9 \succ 11 \succ 10 \succ 12 \succ 6 \succ 1 \sim 2 \sim 3 \sim 4 \sim 5 \quad (4.1)$$

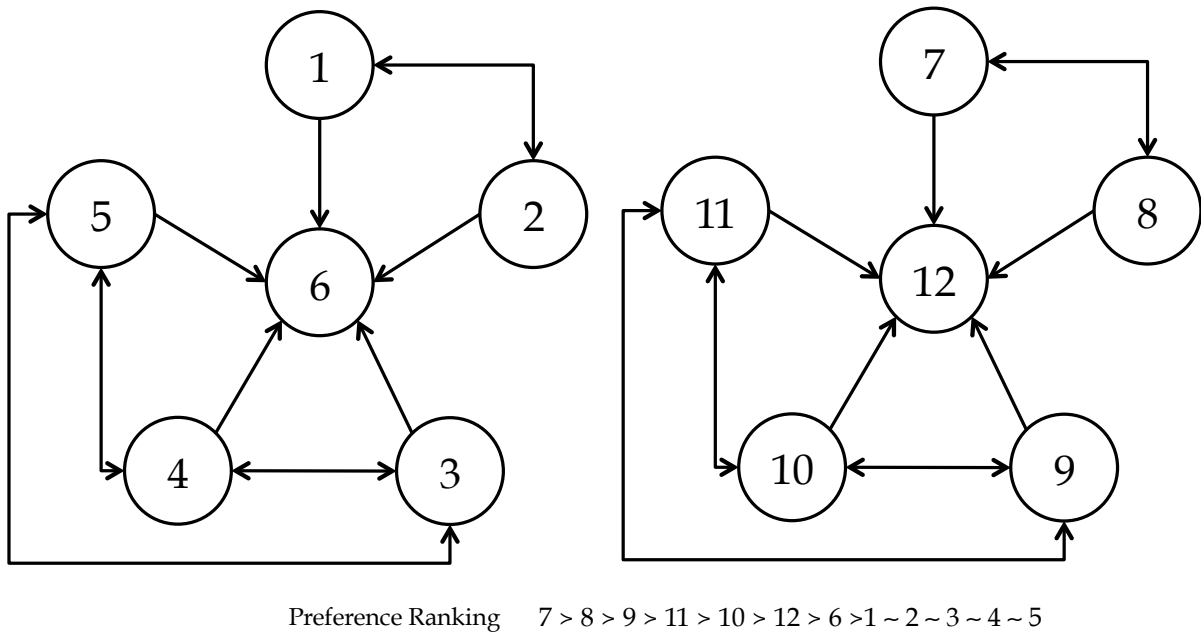

Figure 4.5: The Graph Model for Brinco

In Figure 4.5, all elements of the graph are represented: states by numbered nodes referring to each feasible states', oriented arcs, which represent possible unilateral moves

for Brinco, and finally preferences, which are written at the bottom of the graph. Although the preferences are written with the graph, they seem more like an attachment to the graph rather than an original element of the graph. This leads to the proposed improvement in the graph model, which is presented in the next section.

The Preference Graph Model for Brinco

Utilizing the same illustrative example given in Section 4.4, the enhanced graph model as shown in Figure 4.6 represents the proposed developments in the graph model. Solid arcs represent preferred unilateral moves for Brinco (M_i). All solid arcs in this graph are reversible, except the moves to node 6 where a vertical line crosses the solid arc, \mapsto or \mapleftarrow , which represent an irreversible move (V_i). The dashed arcs represent preferences but not actual moves. Thus, Brinco would prefer to move from state 9 to 8 but cannot do so unilaterally (U_i). The combined nodes of (1,2) and (3,4,5) represent groups of equally preferred states, where Brinco can unilaterally move within each group. The main advantage of the enhanced graph is that preferences are embedded in the graph, helping the analyst to find states that are stable for the DM. Moreover, knowing which moves are desired but not available to the DM can be used to understand the evolution of a conflict.

4.5 Conclusions

This work provides the basis for the analysis of long-term conflicts. In long-term conflicts, there is a need to define the parameters of the original conflict in order to understand whether or not disputes over the same issue can be analyzed and attributed to the original

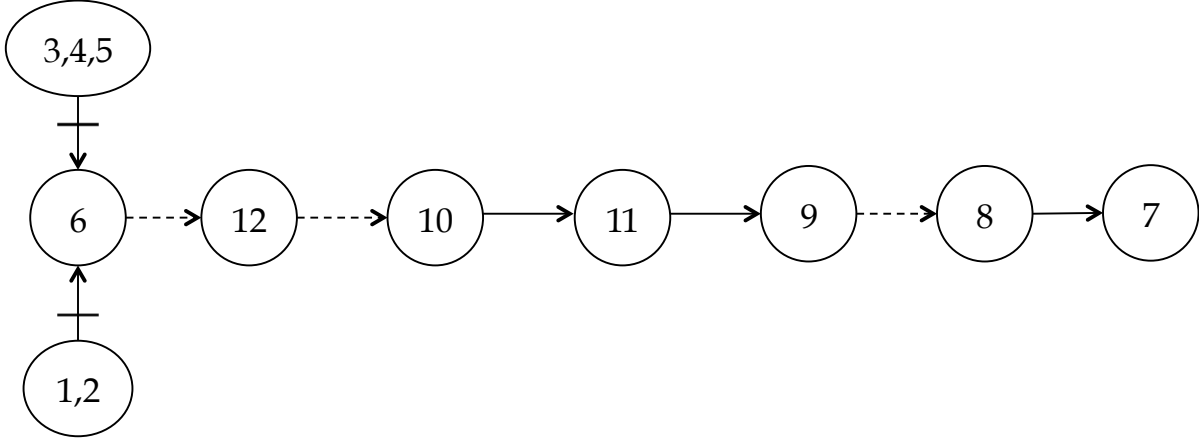

Figure 4.6: The Preference Graph Model for Brinco

or not. Conflict analysis requires that a conflict is studied from the beginning. Modes of the conflict provide a framework to define stages of a conflict from goal realization, to initiation and resolution. Also, an analyst should pay more attention to the macro level of a conflict for the purpose of resolution. The parameters of the conflict can define which features are unique to the attribution and which are not.

Moreover, embedding the preferences of a DM in the graph not only facilitated the understanding of unilateral improvements and desired moves, but also simplified the analysis and recognition of certain individual stability conditions. However, even though the preference graph in its current form does not account for intransitive preferences, most real life conflicts have transitive preferences. The original graph model can account for intransitive preferences by providing a list of pairwise comparison of all states attached to the graph.

4.6 Chapter Summary

The fact that a conflict takes place in many rounds can obscure its nature. This research aims to answer the question of how to determine whether several rounds of a conflict happening at different points in time are connected. A conflict starts when a decision maker challenges a status quo. A decision maker can be involved in more than one conflict at a time; the features that differentiate conflicts are the objectives of the decision makers. The objectives are reflected in the decision makers' preferences over outcomes. The ultimate goal for a decision maker in a conflict is to obtain the most preferred achievable state.

In addition, GMCR is enhanced to provide the analyst with more in-depth information about an underlying conflict. This improvement is achieved by representing decision makers' preferences within the graph, which makes it possible to infer Nash stability condition by glancing at the graph.

Chapter 5

Robustness of Equilibria in the Graph Model for Conflict Resolution

Strategic conflicts can be formally modelled and analyzed using the Graph Model for Conflict Resolution (GMCR) ([Kilgour et al., 1987](#); [Fang et al., 1993](#); [Hipel, 2009a,b](#); [Kilgour and Eden, 2010](#); [Hipel et al., 2011](#)), which utilizes various stability concepts to determine possible equilibria or resolutions to a given conflict, and thereby obtain strategic insights. It has been observed that some real world conflicts demonstrate that it is possible for conflicts to continue evolving even after reaching an equilibrium ([Matbouli et al., 2013a, 2014b](#)). Therefore, further analysis of equilibrium robustness is desired in order to gain some insights about the sustainability of a resolution. In this research, robust equilibrium is not necessarily a binary relation; instead, robustness can be viewed as a level in which equilibria are ranked from most robust to least robust. Such a methodology, for example, will make it possible to distinguish between stable states, where, for instance, in the sense of GMCR, a specific Nash equilibrium can be more stable than another Nash equilibrium.

A new formal robustness of equilibrium analysis is introduced within GMCR, which

will provide insights for better understanding the evolution of long-term conflicts. Refined stability definitions are presented, which facilitates the evaluation of equilibrium robustness, thereby making conflict resolution more sustainable. In the following sections, a background on strategic long-term conflicts is summarized. Then, a formal methodology for analyzing robust stability and ranking procedures to assess equilibrium robustness are proposed. The new strategic approach is applied to a groundwater contamination dispute that took place in Elmira, Ontario, Canada. Subsequently, strategic results and insights obtained when applying robustness of equilibria analysis, are discussed. The contents of this chapter are based on the publications by [Matbouli et al. \(2013c, 2014a, 2015c\)](#)

5.1 Background

5.1.1 Strategic Conflicts

Strategic conflicts are a complex form of decision making ([Jeong et al., 2008](#)) where each decision maker (DM) considers his or her options while thinking about other DMs' moves. In such a situation, a DM cannot achieve a desired outcome without carefully anticipating the decisions of opponents. Conflict conditions exist when two or more DMs pursue incompatible goals ([Galtung, 2008](#)). Modelling and analysis of these interactive decision-making problems have been widely implemented using game-theoretic methodologies, such as GMCR. The development of the graph model started in 1987 by [Kilgour et al. \(1987\)](#), while the first book on the topic was written in 1993 by [Fang et al. \(1993\)](#). It has been widely used around the world in various application areas such as environmental conflicts ([Kilgour et al., 2001](#)), energy disputes ([Matbouli et al., 2014b](#)), negotiations ([Sheikhmohammady et al., 2010](#)), policy design ([Zeng et al., 2004](#)), and business applications ([Kilgour and Hipel, 2005](#)).

5.1.2 Long-term Conflicts

The need to study the robustness of equilibria is recognized because some real world conflicts, such as the great Canadian hydroelectric power conflict (Matbouli et al., 2014b), continued to evolve even after reaching a predicted resolution, thereby creating a challenge to modelling and analysis. For the purpose of analyzing such conflicts, a new concept of robustness of equilibria is introduced to make the classification of resolutions possible, and permit the examination of the sustainability of different solution concepts. As Figure 5.1 shows, after an active conflict reaches an equilibrium, it may or may not transform into a long-term conflict if preferences change. A measure of equilibrium robustness is introduced in the methodology section.

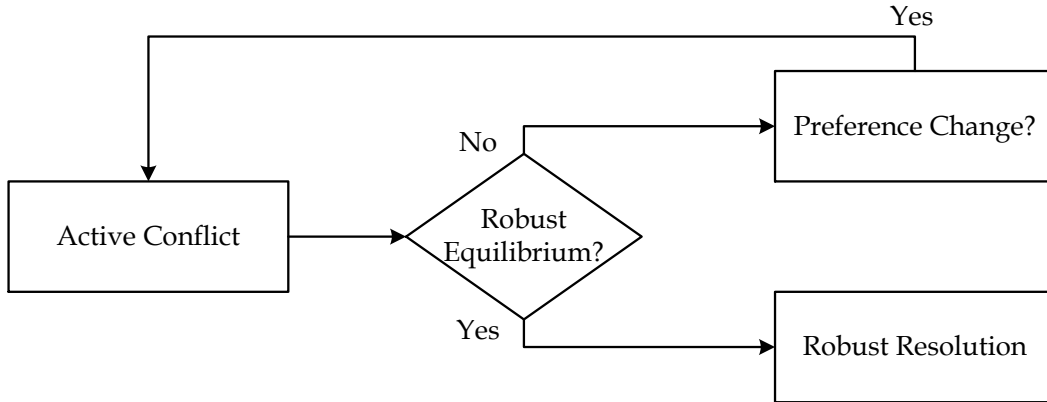

Figure 5.1: Long-term Conflict

5.1.3 The Graph Model for Conflict Resolution (GMCR)

The definitions of GMCR and stability concepts of Nash, SEQ, GMR, and SMR are given in Section 2.3 starting from page 10 of this dissertation.

5.1.4 Robustness of Equilibria

Although robustness of equilibria is a fresh concept in GMCR, the term robustness of equilibria is not entirely new, as it has been used in game theory settings by [Fudenberg et al. \(1988\)](#), and it has also been suggested that some equilibrium states are more stable than others ([Kohlberg and Mertens, 1986](#)). Methodologies have been put forward to further refine the definition of equilibrium in order to find the most stable, robust, or likely equilibrium, by assigning probabilistic weights to opponents' strategies to exclude unlikely equilibria.

Examples of robustness of equilibria approaches in game theory include perfect equilibrium ([Selten, 1975](#)), proper equilibrium ([Myerson, 1978](#)), strategically stable equilibrium ([Kohlberg and Mertens, 1986](#)), and robust equilibria of potential games ([Ui, 2001](#)).

Moreover, robustness can be attributed by the flexibility of DMs ([Rosenhead et al., 1972](#); [Rosenhead and Wiedemann, 1979](#); [Rosenhead and Mingers, 2001](#)). In this respect, a DM makes robust decisions by maintaining flexibility against unforeseeable changes in future.

However, in long-term conflicts in general, and in GMCR in particular, the interest is not to predict the most likely equilibria. Instead, the goal is to find which equilibria are more resilient to change, and sustainable in relative comparison, in other words, which equilibria are more likely to persist despite future uncertainties or gradual preference changes.

Therefore, a fresh concept in conflict resolution, Level of Freedom (LoF) ([Matbouli et al., 2014a](#)), was introduced as a new measure in equilibrium robustness. A formal framework for equilibrium analysis is presented in the next section.

5.2 Methodology

Strategic long-term conflicts take place when two or more interested parties seek incompatible objectives (Galtung, 2008). Although equilibria can be seen as resolutions for such conflicts, the tendency of conflicts to evolve can be attributed to many reasons, one of which is the changing of preference. Future changes in preferences can be hard to predict. When a preference change takes place, the stability concepts of individual stabilities of DMs at some states no longer hold. Preferences can change for a number of reasons, for example, a change in goal realization because of external or internal factors. Take, for instance, a conflict arising over the utilization of limited water resources. When the demand of one region increases, more water needs to be drawn, which could put a prior agreement at risk of initiating a conflict.

There are three main input parameters for GMCR: DMs, options, and preferences. The reliability of equilibria states, which are the output of GMCR, depends on the quality of the inputs. Because uncertainty is prevalent in real world conflicts, DMs, options, and preferences can be assumed to be characterized by high variability. To account for uncertainty of conflict parameters, there are a number of extensions to the original graph model which account for uncertainty at the present or historical state of a conflict, such as fuzzy preferences (Al-Mutairi et al., 2008; Bashar et al., 2012), and stochastic preferences (Rêgo and Santos, 2013). If uncertainty exists in the present conditions of a conflict, future changes are even more uncertain (Pye, 1978). The robustness of equilibrium method provides insights into the sensitivity of stable states against future changes by considering available moves DMs.

In the proposed enhancement, the information about DMs, options, and preferences is assumed to be complete. However, considering the risk of future changes, some Nash

stable states can be more robust than other Nash stable states based on the possibility of deviation from the state on account of future changes.

5.2.1 Factors in Equilibrium Robustness

Robustness of an equilibrium is a relative measure that is dependent on the characteristics of a particular conflict being studied. The comparison and evaluation of equilibrium robustness is based on three factors: Level of Freedom (LoF) ([Matbouli et al., 2014a](#)), type of individual stability, and relative preference. The thought process that led to the idea of LoF started by looking for possible unilateral escapes from stable states.

Level of Freedom (LoF)

In ongoing long-term conflicts, some equilibrium conditions may remain satisfied even when the preferences of one or more DMs change in a new round. This situation can be linked to the availability of moves; for example, when a DM has no possibility of moving from an equilibrium, the conditions for stability will be maintained.

The level of freedom (LoF) constitutes a rough measure to assess relative resistance to a stability disruption in cases of preference change ([Matbouli et al., 2014a](#)). If a DM changes his or her preferences for any reason, a stability condition may not be maintained. Therefore, the concept of LoF evaluates the robustness of stability of a given state for a particular DM, by counting the number of unilateral moves available to the DM. If the focal DM has a high LoF, it means that even a small change in preference would likely disturb the equilibrium. If the LoF is very low, or if it is zero, even a dramatic change in preference will not affect the equilibrium.

Assume that DMi finds states s_1 and s_2 to be Nash stable. Assume also that from state s_1 , there is no unilateral move available to DMi , while at state s_2 there are three available moves that are disimprovements for DMi . Now, both states are Nash, but which state is more stable? For the case of preference change for DMi , his or her stability at state s_1 cannot be affected. For state s_2 , however, if the preference change for DMi makes an available move a unilateral improvement, then the conditions of Nash stability at state s_2 will no longer be valid. Thus, even though both states s_1 and s_2 are Nash stable, state s_1 is more robust than state s_2 .

LoF can be calculated in a number of ways. For example, one may count the available number of moves from the present state in one step to other states. Or an analyst may choose to extend the horizon to calculate the number of moves in two or three consecutive steps ahead. However, LoF should be interpreted only relatively. The difference between LoFs of 4 and 5 may not be significant, but larger differences in LoF tend to indicate a significant difference in the robustness of the states. A state is *Absolutely Robust* for an individual stability concept, as introduced in Section 5.2.2, when LoF is zero, the absolute minimum for a stability definition.

In this chapter, a two-step calculation has been chosen for LoF, by counting the number of unilateral moves from the present state, regardless of the type of move: unilateral improvement, disimprovement, or neither. States that are one move ahead from the present state can be endpoints or transitional nodes. There is the possibility to encounter two-step loops that return to the initial state. Since the aim is to find the robustness of a state relative to another state, the count of the number of moves was limited to two sets of moves. The first set of moves is counted from the present state to the next endpoint. The second set of moves is counted based on the number of moves leading to transitional nodes multiplied by two. *LoF* is defined as follows (Matbouli et al., 2014a):

Definition 8. $LoF_i(s) = 2c - d$, where c is the number of UMs from state s , and d is the number of UMs from state s that lead to a stable state for the DM.

In addition, state s_1 in the above example, which is a Nash stable state with no possible unilateral moves, is called an *Absolutely Robust* state. Further definitions related to absolute robustness are presented in Section 5.2.2.

Moreover, calculating LoF for each DM at every state, can produce some interesting properties, some of which are given below:

1. If a state s has an $LoF_i(s) = 1$, then s is Nash stable for $DM i$ iff $s \succ_i R_i(s)$.
2. If for a state s the number of feasible states is not greater than $LoF_i(s) + 1$, then $DM i$ can move unilaterally from state s to any state in the conflict.
3. If $LoF_i(s) = 0$ and $R_i(q) = s$, then the move from q to s is irreversible.
4. If, for all states $s \in S$, $LoF_i(s) = 0$, then $DM i$ has no choices in the conflict.
5. If $LoF_i(s) = 0$, then s is Nash, SEQ, GMR, and SMR stable for $DM i$.

Types of Individual Stability

There are four types of stability considered for robustness of equilibria analysis: Nash, SEQ, GMR and SMR. It is generally accepted that Nash and SEQ stability concepts are stronger than GMR and SMR, because of the sociological assumption that supports each stability definition. In Nash, the DM is assumed to move unilaterally when a better outcome is achieved. In SEQ, the DM avoids making a UI, fearing a credible threat which will put his or her opponent in a better position while harming the focal DM. On the other hand, in GMR and SMR stable states, the focal DM is assumed to abstain from making

a unilateral improvement to avoid a less credible sanctioning. In GMR and SMR, the threat of sanctioning assumes that an opponent DM may harm his or her own position in order to put the focal DM in a worse state. This assumption is less likely than the general assumption that in strategic conflicts, DMs seek to improve their outcome and not the reverse.

In order to rank individual stabilities, LoF is measured in two separate categories: strong stability concepts: (Nash and SEQ), and weak stability concepts (GMR and SMR). Initially, all Nash and SEQ states are assumed to be more robust than GMR and SMR states. In addition, within each category, the lower the LoF, the higher the robustness ranking of individual stability with respect to the focal DM.

Preferences

Since LoF assesses the possibility of deviation in case of preference change, it is useful to consider preferences when ranking equilibrium robustness. Assume that a $DM i$ has the same LoF at two stable states of the same type. To determine which state is more robust in this case, it is plausible to compare the preferences of both states. The state that is more preferred to the focal DM is considered more robust for the respective DM.

5.2.2 Robust Individual Stabilities

A robust state is a particular case of stability robustness where LoF is equal to the absolute minimum for each stability type. An absolutely robust equilibrium is the state that all DMs find to be robust stable. The robust stable states —Nash, SEQ, GMR, and SMR— are defined below.

Definition 9. $s \in S_i^{RNash} \iff R_i(s) = \emptyset$

Note that state s is a *Robust Nash (RNash Stable)* iff $DM i$ has no UM from s . Thus $S_i^{RNash} \subseteq S_i^{Nash}$, i.e. s robust Nash is Nash. Clearly s is Robust Nash iff $LoF_i(s) = 0$.

Definition 10. $s \in S_i^{RSEQ} \iff \forall q \in R_i^+(s), \exists x \in R_{N-i}^+(q) \ni x \succsim_i s \wedge x \in S_i^{Stable}$

In *SEQ stability*, a DM abstains from making a UI to avoid a credible sanctioning by the opponent. For *Robust SEQ (RSEQ)*, there is at most one possible move that is the UI, and this UI leads to an end point (stable state), not a transitional state. State s is Robust SEQ iff $LoF_i(s) \leq 1$.

Definition 11. $s \in S_i^{RGMR} \iff \forall q \in R_i^+(s), x \in R_{N-i}(q) \ni x \succsim_i s \wedge x \in S_i^{Stable}$.

Likewise, in *Robust GMR (RGMR)*, the number of moves $LoF_i(s) \leq 1$ is similar to the LoF of RSEQ, except that the threat of sanctioning in RGMR is less credible than in RSEQ.

Definition 12. $s \in S_i^{SMR} \iff \forall q \in R_i^+(s), \exists x \in R_{N-i}(q) \ni x \succsim_i s \wedge \forall h \in R_i^+(x) \ni h \succsim_i s \wedge x \in S_i^{Stable}$

The focal DM, who finds a state to be *SMR stable*, considers two moves ahead from the present state, so there is at most 2 unilateral moves. Thus, a Robust SMR state has a $LoF_i(s) \leq 2$.

In the definitions above, it can be observed that UD's are taken into consideration when performing robust stability analysis (see Table 5.1). The number of moves considered ahead is no different from regular stability definitions as seen in Table 2.1. However, there are more types of future moves considered.

Table 5.1: Foresight of Focal Decision Maker in Different Robust Stability Conditions

Stability Definitions	Foresight	Focal DM	Opponent DM
Robust Nash (RNash)	One move	UI, UD	-
Robust Sequential Stability (RSEQ)	Two moves	UI, UD	UI
Robust General Metarationality (RGMR)	Two moves	UI, UD	UI, UD
Robust Symmetric Metarationality (RSMR)	Three moves	UI, UD	UI, UD

5.2.3 Ranking of Robustness of Equilibria

In order to relatively rank equilibria robustness, two steps of the ranking are performed. First, each individual stability that results in equilibrium is ranked from an individual DM’s perspective. Then, the overall ranking is ordered based on individual ranking of stable states.

Ranking of Individual Stability

The interest here is only to rank states that represent equilibria. So this is kind of a reverse process. After individual stability analysis is performed, and equilibria points are defined, we go back to individual stability states and select only those pertaining to equilibria.

For each DM, rank the individual states based on LoF in two groups: one is the group of Nash and SEQ stable states, and the other group consists of GMR and SMR stable states. For each group, the states are ranked from most robust to least robust, with the state having the lowest LoF regarded as the most robust. Then combine the ranking of both groups by assigning all Nash and SEQ stable states a higher order of robustness than GMR and SMR states. Ties in ranking are acceptable at this stage. Assign an order number for each individual state from each DM’s perspective as seen in the first section of Table 5.2.

Overall Ranking of Equilibria Robustness

For each state, combine the order number given from each DM's perspective (see Table 5.2). The states are ranked based on the summation of ranks for each state from most robust to least robust. The lower the order of ranking, the higher the robustness. For ease of interpretation, re-adjust the order number with the lowest order starting at 1. At this stage, in case of a tie in ranking, we investigate the preferences according to either methodology discussed in Section 5.2.1. However, if the equilibrium states have exactly the same LoF and type of stability, then ranking equilibrium robustness based on LoF is not currently possible. This is because the possibility of deviation from equilibria will be identical among equilibrium states.

Table 5.2: Ranking of Equilibrium Robustness

DMs	Equilibrium States			
	s_1	s_2	\dots	s_n
DM_1	$Rank_1(s_1)$	$Rank_1(s_2)$	$Rank_1(\dots)$	$Rank_1(s_n)$
DM_2	$Rank_2(s_1)$	$Rank_2(s_2)$	$Rank_2(\dots)$	$Rank_2(s_n)$
\vdots	\vdots	\vdots	\vdots	\vdots
DM_N	$Rank_N(s_1)$	$Rank_N(s_2)$	$Rank_N(\dots)$	$Rank_N(s_n)$
Overall Ranking	$\sum_{i=1}^N (Rank_N(s_1))$	$\sum_{i=1}^N (Rank_N(s_2))$	$\sum_{i=1}^N (Rank_N(s_{\dots}))$	$\sum_{i=1}^N (Rank_N(s_n))$

5.2.4 Insights from Level of Freedom

The utilization of LoF can provide interesting insights that not only rank equilibria according to robustness, but also highlight general assessments about the robustness of stable states for DMs in a conflict.

Theorem 5.2.1. *Suppose that, for DM i , $\sum_{s \in S} LoF_i(s) \leq n$, where n is the total number*

of feasible states. Then, there is at least one state that is Nash, and RNash for DM i .

Proof. If the total LoF_i is less than the number of feasible states, then one or more states must have $LoF_i = 0$. □

Theorem 5.2.2. For a 2-DM conflict $\{i, j\}$, suppose DM j has $LoF_j(q) = 0$. Then, DM j cannot sanction any move by DM i to state q

Proof. If $LoF_j(q) = 0$, then DM j has no unilateral move from state q . Therefore, DM j cannot sanction any move by his or her opponent. □

Theorem 5.2.3. If state s is RNash for DM i , the state s is also RSEQ for DM i .

Proof. If state s is RNash for DM i , then Definition 10 for RSEQ is satisfied, because $R_i(s) = \emptyset$ □

Theorem 5.2.4. If state s is RSEQ for DM i , the state s is also RGMR for DM i

Proof. If state s is RSEQ for DM i , then Definition 11 for RGMR is satisfied, since $R_i^+(s) \subseteq R_i(s)$ □

Theorem 5.2.5. If state s is RNash for DM i , the state s is also RSMR for DM i .

Proof. If state s is RNash for DM i , then Definition 12 for RSMR is satisfied, because $R_i(s) = \emptyset$ □

The above interrelationships among robust individual stabilities are similar to the standard stability concepts (Fang et al., 1993). Moreover, it is also noteworthy that each robust stability definition is a subset of the original corresponding stability definitions, as depicted in Figure 5.2. For example, if state s is RNash, then state s is also Nash stable, because $S^{RNash} \subseteq S^{Nash}$.

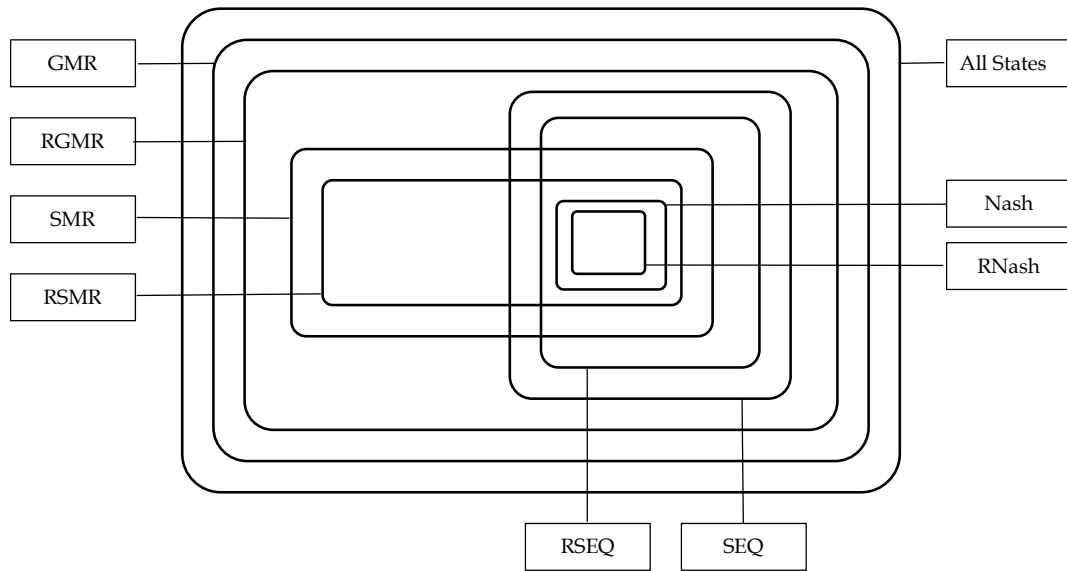

Figure 5.2: Interrelationships between Robust and Standard Stability Concepts

5.3 Case Study: Elmira Groundwater Contamination Conflict

In 1989, the contamination was discovered in the drinking water source of Elmira, which is a Canadian town located in southwestern Ontario, about 100 km west of Toronto. The contamination was attributed to chemical discharges released by *Uniroyal Chemical Ltd. (UR)*, which ran a chemical plant. *The Ontario Ministry of Environment (MoE)* issued a control order demanding *UR* to remediate the water pollution. *UR* appealed the control order issued by *MoE*, while the *local government (LG)* insisted that the *MoE* enforce its initial control order without modification of the original control order (Hipel et al., 1993; Mehta and Oullet, 1995). Eventually, *MoE* modified its control order, and *UR* accepted it.

5.3.1 Background

The events that followed the discovery of the water contamination at Elmira are modelled using the graph model for conflict resolution. This water conflict has been modelled previously by [Hipel et al. \(1993\)](#) using GMCR. The same conflict is modified by removing *LG* from the model. This seems plausible because the *LG* did not have much say in the conflict other than insisting to *MoE* to keep its original control order. In addition, the deal between *MoE* and *UR* came as a surprise to *LG*. However, robustness of equilibria of the original model has also been analyzed in ([Matbouli et al., 2015c](#)).

5.3.2 Modelling of Elmira Groundwater Contamination Conflict

This conflict is modelled at the point where *UR* appealed the control order. The *MoE* has two options: modify the control order to appease *UR* or not. *UR*, on the other hand, could delay responding to the control order, accept it, or abandon the plant. A summary of the DMs and their options are given in [Table 5.3](#). The feasible states are also shown in [Table 5.3](#). The letter “Y” in the table indicates “Yes” and “N” indicates “No” for each corresponding option. [Figure 5.3](#) represents the integrated graph model of the conflict, where available moves for each DM are shown.

5.3.3 Stability Analysis

Stability analysis is performed in [Table 5.4](#) (r) indicates a rational state (Nash), and (u) indicates an unstable state. For *MoE*, all states are Nash stable, because *MoE* has no UIs from any state. *UR* finds all states to be stable except states 3 and 2. UDs are shown but not used in regular stability analysis; however, they will be used in calculating LoF.

Table 5.3: Elmira Conflict: Decision Makers, Options, and States

DMs & Options	States				
	1	2	3	4	5
MoE					
1. Modify	N	Y	N	Y	-
UR					
2. Delay	Y	Y	N	N	N
3. Accept	N	N	Y	Y	N
4. Abandon	N	N	N	N	Y

Overall, the analysis of the model results in three equilibria: states 1, 4, and 5. Analysis of equilibria robustness is presented in the following section.

5.3.4 Analysis of Equilibria of Elmira Water Conflict

For the three equilibrium states $\{s_1, s_4, s_5\}$, LoF is calculated for *MoE* and *UR* at each state as shown in Table 5.5. On the right column of Table 5.5, states are ranked based on robustness for each DM respectively. Then, in Table 5.6 the overall equilibria robustness is represented. It shows that state s_5 is the most robust state. Also, it meets the requirement for the special case of absolutely robust equilibrium. This means that if the conflict reaches to state s_5 , it is not possible to destabilize the conflict, even in the case of preference changes, because there are no moves available for any DM. State s_5 represents the situation where *UR* abandons the plant. According to the model this is an irreversible move for *UR*, and *MoE* has no moves from s_5 .

The least robust state is s_1 , which represents the situation where *MoE* refuses to modify its control order, and *UR* delays. This state clearly cannot be a permanent resolution.

Finally, state s_4 represents the situation that took place, where *MoE* modifies the

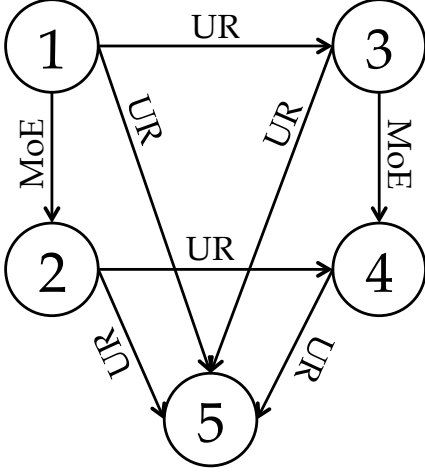

MoE Preferences = {3, 4, 1, 2, 5}
 UR Preferences = {1, 4, 5, 3, 2}

Figure 5.3: Graph Model for the Elmira Water Conflict

control order, and *UR* accepts it, which is less robust than state s_5 , because if *UR* changes its preference, it can abandon the project. This scenario is possible, for example, if market conditions become unfavourable for *UR* causing it to lose profits. In such a case, *UR* may change its preference and prefer state s_5 over s_4 , which will disturb the stability conditions at state s_4 .

In addition, see Figure 5.4, which shows available moves from each equilibrium state. Looking at the graph, it can be inferred that the results of *LoF* are consistent with possible escapes as shown in the graph. For state 1, there seems to be many possible escapes compared to states 4 and 5. It can be deduced from the graph that state 5 is the most robust equilibrium because there is no way any DM can move away from this equilibrium. State 1, on the other hand, has the highest possibility of escape among equilibria states.

Table 5.4: Elmira Conflict: Decision Makers, Moves, and States

DMs & Moves	States				
Equilibrium States	X	E	E	X	E
MoE					
Preferences	3	4	1	2	5
Stability	r	r	r	r	r
UIs					
UDs	4		2		
UR					
Preferences	1	4	5	3	2
Stability	r	r	r	u	u
UIs				5	4
					5
UDs	3	5			
	5				

Table 5.5: Levels of Freedom and Individual Stability Ranking

DMs	Levels of Freedom			Robustness Ranking of Individual Stability
	s_1	s_4	s_5	
MoE	1	0	0	$\{s_4, s_5\} > \{s_1\}$
UR	3	1	0	$\{s_5\} > \{s_4\} > \{s_1\}$

5.4 Conclusions

In this chapter, a formal analysis of *robustness of equilibria* is presented to provide insights on the resiliency of equilibria to change in preference. The result can be insightful as seen in the case study of the Elmira groundwater contamination conflict. This approach provides an interesting view on the possibility of deviation from equilibrium. The essence of the new approach is the concept of LoF. GMCR defines stability based on moves and preferences, and a DM is confined to available moves, but his or her preferences can change. Perception of goals over time can cause preferences to change. Also, external factors such as

Table 5.6: Overall Ranking of Equilibria Robustness for the Elmira Conflict

DMs	Ranking of Equilibrium		
	s_1	s_4	s_5
MoE	2	1	1
UR	3	2	1
Overall Ranking	5	3	2
Adjusted Ranking	3	2	1
States Ranking	$\{s_5\} > \{s_4\} > \{s_1\}$		

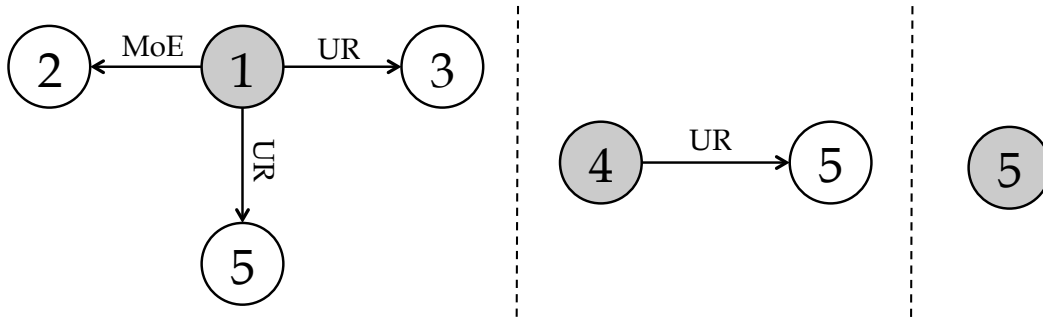

Figure 5.4: Possible moves from Equilibria States

increased demand or natural phenomena may provide opportunities to disturb equilibria. Ranking of equilibrium robustness is helpful to the analyst who is interested in ascertaining which equilibria are more sustainable than others. This could be especially useful for third party interveners attempting to resolve a long-term conflict. This research is the first to introduce a systematic approach to robustness analysis within the graph model for conflict resolution.

5.5 Chapter Summary

A novel approach for assessing the robustness of an equilibria in conflict resolution is presented. Roughly, an equilibrium is robust if it is resilient, or resistant to deviation.

Robustness assessment is based on a new concept called Level of Freedom, which evaluates the relative freedom of a decision maker to escape an equilibrium. Resolutions of a conflict can be affected by changes in decision makers' preferences, which may destabilize an equilibrium, causing the conflict to evolve. Hence, a conflict may become long-term and thereby continue to evolve, even after reaching an equilibrium. The new robustness measure is used to rank equilibria based on robustness, to facilitate distinguishing equilibria that are relatively sustainable. An absolutely robust equilibrium is a special case in which the Level of Freedom is at an absolute minimum for each individual stability definition.

Chapter 6

Multi-Level Options for the Graph Model for Conflict Resolution

This chapter is largely based on two publications ([Matbouli et al., 2015a,b](#)). An expansion of the options structure is proposed to make the option-based graph model for conflict resolution more explicitly expressive of reality. The suggested improvement provides an opportunity to replace binary (on or off) options with multi-level options, wherein the decision maker (DM) selects one out of more than two distinct levels. The new approach simplifies the representation of conflicts and facilitates the understanding of their evolution by including outcomes that involve partial achievement of a DM's objectives. With multi-level options, the preferences of decision makers can be related to the possibility of tradeoffs between (or among) options.

The option form of the graph model for conflict resolution ([Kilgour et al., 1987](#); [Fang et al., 1993](#); [Hipel, 2009a,b](#); [Kilgour and Eden, 2010](#); [Hipel et al., 2011](#)) is practical and convenient, making graph models easy to construct in relatively few steps. But the current restriction to binary options can be a hindrance, as on-or-off options do not seem to

express the real choices of decision makers (DMs) ([Matbouli et al., 2015b](#)). In this chapter, multi-level options are introduced to provide a representation that captures some essential features of the decision-making process. What is usually thought of as a single option may be undertaken at a range of levels. For example, when a DM offers to sell a property, he or she may adjust the sale price strategically, depending on preference for waiting time. Selecting a relatively high asking price—and waiting for a willing buyer—may be preferable, or not, to selecting an average market price and expecting an average wait until sale, or offering to sell at a price lower than the estimated market value in order to gain a quick sale.

The option form ([Howard, 1971](#)) of the graph model for conflict resolution ([Kilgour et al., 1987](#); [Fang et al., 1993](#); [Hipel, 2009a,b](#); [Kilgour and Eden, 2010](#); [Hipel et al., 2011](#)) uses binary options, i.e. with two levels only. If there is an option that is “inherently” multi-level, the analyst must treat each of the levels as an independent binary option. This modelling technique has several disadvantages. First, the binary options representing a multi-level option are not independent, and must be linked by an at-most-one restriction on feasibility – that is, any option combination including two or more of these options must be declared infeasible. Second, there is redundancy in options, making a DM’s list of options that much longer. It can be difficult to keep track of binary options that are components of multi-level options, versus those that are independent. Third, difficulties can arise in expressing the preferences of a DM with a multi-level option given as a set of binary options, which must be linked. For example, it is easier to think of bargaining about the level of an option rather than about which binary option is to be selected. In a graph model of a negotiation, a DM’s choice to change options in response to the opponent’s selections is crucial, and is also an important factor in understanding the evolution of long-term conflicts.

The next section provides background on the graph model for conflict resolution, especially the original option form. Then, the proposed expansion to multi-level options is presented, followed by a case study of the Great Canadian Hydroelectric Power conflict, where both two- and multi-level options can be utilized and compared.

6.1 Background

The Graph Model for Conflict Resolution (GMCR) uses directed graphs to represent the dynamics of a strategic conflict in an informative manner. Relative to other forms of a conflict model, a graph model is characterized by its flexibility; it can represent all types of moves, and handle a rich range of preference structures, including intransitive ones. In fact, the graph model is the only modelling technique that can represent the reversibility of moves, an important feature that normal form games cannot represent. As also given in Section 2.3, the graph model is defined as follows:

Definition 13. *The graph model for conflict resolution (Fang et al., 1993) is defined as $G = \langle N, S, \{A_i : i \in N\}, \{\succ_i, \sim_i; i \in N\} \rangle$ where $N = \{1, 2, 3, \dots, n\}$ is the set of DMs; $S = \{1, 2, 3, \dots, s\}$ is the set of feasible states; $A_i \subseteq S \times S$ is the set of unilateral moves available to DM_i ; and $\{\succ_i, \sim_i\}$ is a strongly complete preference relation for DM_i , such that, for any $s, q \in S$, $s \succ_i q$ means state s is more preferred than state q , and $s \sim_i q$ indicates that state s is indifferent to state q for DM_i .*

Definition 14. *For each $DM_i : i \in N$, the directed graph of DM_i , $G_i = \langle S, A_i \rangle$ contains the states of the model, S , as vertices (nodes), and the possible moves as arcs (edges) A_i . A DM_i possesses an arc, (s, q) from state $s \in S$ to state $q \in S$ if and only if DM_i has a unilateral move from s to q . Beginning at any state $s \in S$, DM_i 's reachable list is the set of all $q \in S$ such that $(s, q) \in A_i$.*

Definition 15. *The (binary) option form of the graph model is based on a finite set of options O and an ownership function $g : O \rightarrow N$ indicating that option $k \in O$ is owned (exercised, or not) by $DM_{g(k)}$. Options are combined to form the set of possible states; a possible state is a subset $K \subseteq O$ of options. Thus, the set of possible states is the power set 2^O , consisting of all possible subsets of options. Of course, feasibility must be determined separately as, for example, some pairs of options cannot be selected simultaneously.*

For each $i \in N$, let O_i denote the set of options controlled by DM_i . Then $O_i = \{k \in O : g(k) = i\}$. A strategy is a choice of options from O_i . A state in S results as soon as each DM chooses a strategy, which is associated with 1 or 0 for each option the DM controls. A mapping function $f : O \rightarrow \{0, 1\}$ represents strategy selection for a DM such as:

$$f(o) = \begin{cases} 1 & \text{if } DM_{g(o)} \text{ selects option } o \\ 0 & \text{otherwise} \end{cases}$$

Thus, a possible state is an $|O|$ -vector of strategy selection among DMs, hence, there are $2^{|O|}$ possible states. Feasibility considerations, for example, options that are mutually exclusive, reduce the set of possible states 2^O to $S \subseteq 2^O$.

However, the graph model stability analysis considers only which states are stable if reached, and does not provide a description of how they might be reached, for example by specifying strategies.

6.2 Modelling Using Multi-Level Options

In this section, the proposed new definition of options in the graph model for conflict resolution is introduced. However, before introducing multi-level options, a discussion of

the evolution of long-term conflicts that inspired the expansion of options definition is appropriate.

6.2.1 Evolution of Conflicts

The Great Canadian Hydroelectric Power conflict (Feehan and Baker, 2007; Feehan, 2011; Matbouli et al., 2012b, 2014b) provides an interesting opportunity to understand the conflict evolution over time, and shows that an equilibrium may not necessarily be a permanent resolution. This conflict took place in two historical rounds and one current round, and is expected to continue in the future.

Evolution of conflicts can be thought of in two directions: inside-out or outside-in. In Figure 6.1, the circles represent a conflict that evolves inside-out. In the conventional approach, an equilibrium in the first round is considered to be an endpoint, and any development afterward must be treated as a separate conflict. The problem with this thinking is that the connection between rounds of the conflict is lost, and there is no consideration of whether a resolution is unsustainable. Furthermore, when a conflict evolves into something new and different, its analysis becomes very uncertain. On the other hand, Figure 6.2 shows circles inside each other. The largest represents the first round of the original conflict; the smaller it gets, the closer one DM comes to satisfying his or her objectives. The advantage of this approach to conflict evolution is that the boundaries of a conflict are characterized by the first round, and then the evolution takes place within the boundaries already identified. As a result, the conflict evolves toward one that is less uncertain and more focused on achieving some DM's initial goals.

Moreover, this approach can accept slight changes in the objective within the boundaries defined in the first round so that the objective can vary in magnitude but not in

achievement. For example, if the objective of the conflict is to secure shares of a water resource, the share needed may change, based on circumstances. On the other hand, a change in the issue, for example from securing water share to an unrelated boundary dispute is not considered as an evolution within the boundaries of the first round.

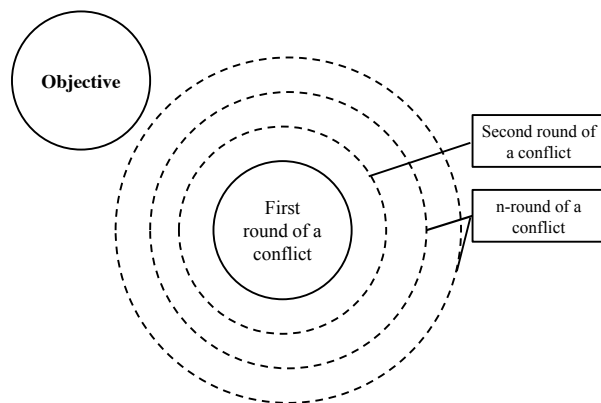

Figure 6.1: Inside-out Evolution of a Conflict

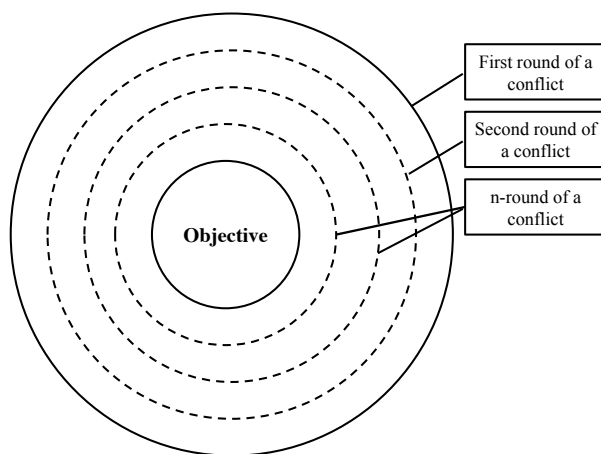

Figure 6.2: Outside-in Evolution of a Conflict

New rounds of the same conflict take place as DMs try to achieve what they failed to achieve in the first round, even though the first round reached an equilibrium. In order

to understand this phenomenon, attention should be directed to the very first round of the conflict, where the conflict changes from incipient to active. At this stage, the issue in dispute is clear. The disadvantage of traditional methodologies is that they treat all options as standalone endpoints, where the concept of bargaining is between the options and not within the options. In fact, options may have levels and dimensions.

In the original graph model for conflict resolution, complete information about the conflict is assumed. The process may continue in that a DM tries to achieve more of the same option that was a component of the original equilibrium. Having only two-level options, the evolution of a conflict can sometimes be hard to model or explain. Utilizing the proposed multi-level options, the graph model not only becomes more expressive, but also more useful in understanding the evolution of conflicts. Partial achievement of objectives through strategic option choices can now be visible to the analyst.

6.2.2 Multi-Level Options

Introducing multi-level options improves the description of a GMCR model by expressing options in GMCR more realistically. Considering levels of options will facilitate the representation of preferences, making the model more informative by covering more possible scenarios in a single model. Moreover, multi-level options can shed light on the possible conflict evolution direction. With binary options, a DM who is unsatisfied with an equilibrium is considered to move away from equilibrium only when a unilateral improvement becomes possible. However, using multi-level options a DM could continue to challenge an equilibrium by trying to improve on the same equilibrium. See Fig. 6.3, which shows two possible paths for conflict evolution, in one of which a DM deviates from an equilibrium to reach another one. On the second path, a DM attempts to improve on the same equilibrium by increasing his or her share in a multi-level option.

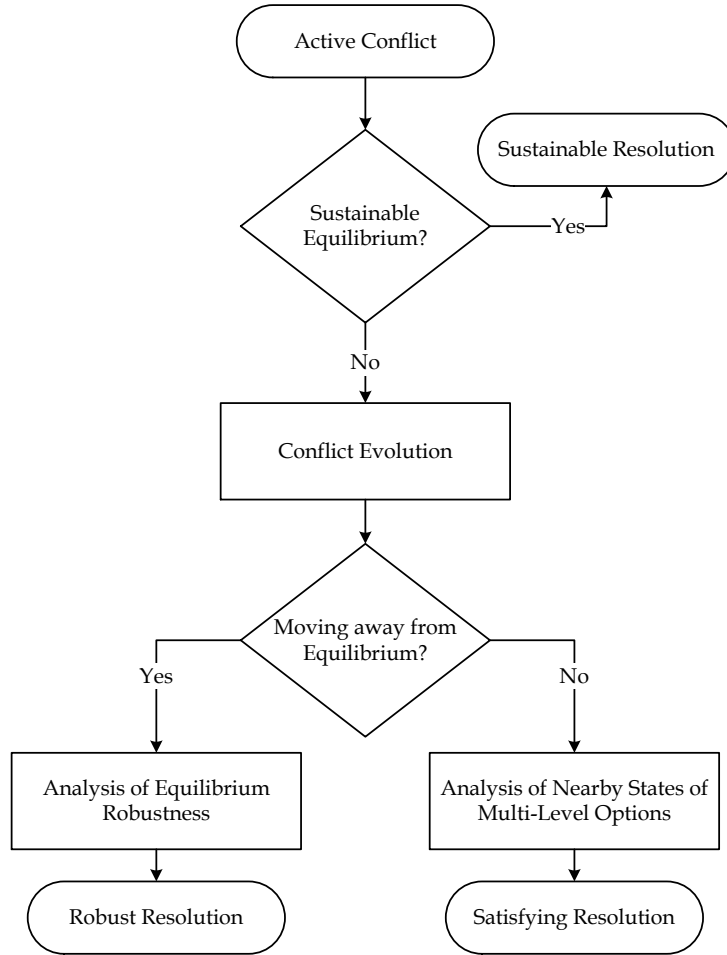

Figure 6.3: Analysis for Sustainable Resolution

The multi-level option form of the graph model is based on a finite set of options O and retains the *ownership function* $g : O \rightarrow N$, which indicates that option $o \in O$ is owned (exercised, or not) by $DM_{g(o)}$.

Definition 16. For each $i \in N$, let O_i denote the set of options controlled by DM_i , thus $O_i = \{k \in O : g(k) = i\}$. A state in S results when a level is specified for each option.

Definition 17. An option $o \in O$ has $v(o)$ levels, where $v : O \rightarrow \{1, 2, 3, \dots\}$. Thus,

the option o has $L(o) = v(o) + 1$ levels. In case $v(o) = 1$, then $L(o) = 2$ meaning that option o is a binary option. For any option $o \in O$, $DM_g(o)$ must choose a level in $M_o = \{0, 1, \dots, v(o)\}$.

Definition 18. A state is an $|O|$ -vector of non-negative integers $(m_1, m_2, \dots, m_{|O|})$ with the property that for option o_j , the integer m_j satisfies $0 \leq m_j \leq v(o_j)$. The number of possible states is $\prod_{j=1}^{|O|} [v(o_j) + 1]$.

In order to make multi-level options easier to understand, a four level option M_k with selection levels high (h), average (a), low (l), or no selection (N), can be represented as $f : M_k \rightarrow \{h, a, l, N\}$. The mapping function is:

$$f(M_k) = \begin{cases} h & \text{if } DM_{g(o)} \text{ selects option } M_k \text{ with a high level of execution} \\ a & \text{if } DM_{g(o)} \text{ selects option } M_k \text{ with an average level of execution} \\ l & \text{if } DM_{g(o)} \text{ selects option } M_k \text{ with a low level of execution} \\ N & \text{otherwise} \end{cases}$$

Definition 19. Nearby states are states that are identical except for the level of one option. When a DM attempts to increase or decrease the level of an option contained in an equilibrium, the DM is said to be attempting to reach a nearby state.

6.2.3 Analysis of Conflicts with Multi-Level Options

The steps to analyze a conflict with multi-level options differ slightly from a conflict with binary options. As shown in Figure 6.4, the process starts with collecting the data about a conflict, which is then used as an input to the GMCR model. In constructing the GMCR

model, the process starts by generating all possible states, and then removing those that are infeasible. In the modelling stage, options are defined as either a binary or multi-level. In case of a multi-level option, there will be some nearby states, which only differ in the level of one option. At the analysis stage, individual stability analysis is performed in accordance with stability concepts as given in Section 2.3.1. By definition, equilibrium arises when all DMs find the same state to be stable. More than one equilibrium within a group of nearby states can indicate that there is a greater possibility of an equilibrium being reached within this group. More importantly, when there is more than one equilibrium within a group of nearby states, at least one of them can be identified as transitional.

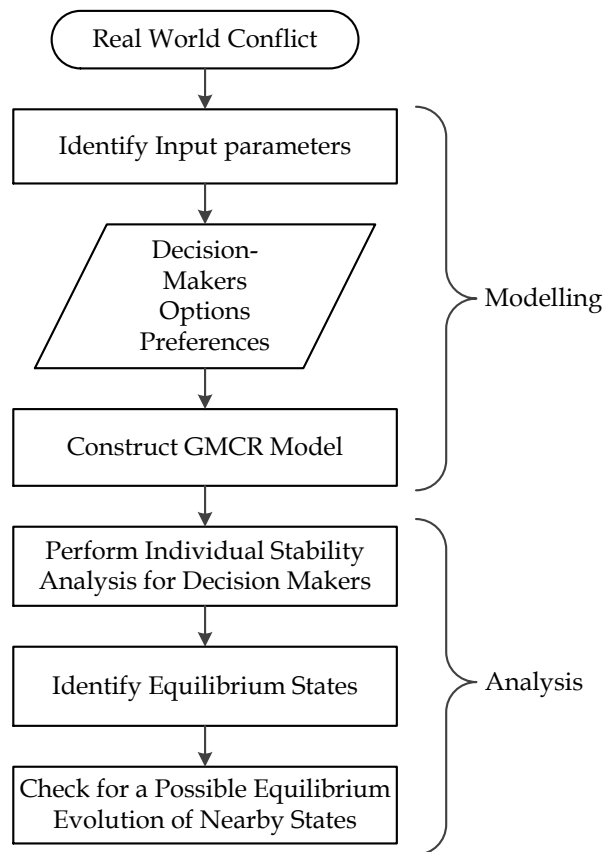

Figure 6.4: Modelling and Analysis of Multi-Level Options

A transitional equilibrium represents a resolution that is not sustainable. A DM may attempt to reach to a transitional equilibrium in order to make a preferred nearby state possible. For example, a startup company may accept deals with very low margins in order to build a customer base or project profiles. When analyzing multi-level options, the startup may have equilibrium with low price and high price deals; the low price equilibrium may be transitional, making higher prices accessible.

In the following section, a modelling the Great Canadian Hydroelectric Power Conflict using both (traditional) binary options and multi-level options is presented.

6.3 Case Study: The Great Canadian Hydroelectric Power Conflict

A conflict between two Canadian provinces Newfoundland and Labrador (NL) and Québec (QC) started in the late 1960s is described in Chapter 3 (Matbouli et al., 2014b). For a protracted period, NL has sold almost all the power it produces from Churchill Falls Hydroelectric Power to QC at a price much below the market value. In order to understand this equilibrium, the negotiations that led the final contract are modelled in Table 6.2 using binary options as originally modelled by Matbouli et al. (2012b, 2014b). Soon after a definitive agreement was signed, NL tried unsuccessfully to amend the original contract; it wanted to improve on the equilibrium by increasing the sale price of hydropower (Matbouli et al., 2014b). The attempts of NL to rectify the price through legal challenges were unsuccessful (The Supreme Court of Canada, 1988a,b).

6.3.1 Modelling with Binary Options

Table 6.1 summarizes the DMs, and binary options available to the DMs during the contract negotiations. Levels of options in Table 6.1 are selections of binary options, denoted by Y , where a DM selects the corresponding option, and N where the DM chooses not to exercise the option. Based on the negotiation model (Matbouli et al., 2012b), Table 6.2 shows the option form with two level options (Matbouli et al., 2012b). On the left side of Table 6.2, there are three DMs: Brinco, QC, and Investors. Brinco is a NL crown company that was given the rights to utilize hydropower potential of Churchill Falls. NL at the time was not in a need for the power for its own use. Instead, the objective of Churchill Falls development is to export hydropower generated electricity to interested buyers in Canada and the United States (Feehan, 2011). In order to sell power, Brinco had to find a way to transmit it. Their transmission options included transmitting power via QC or Maritimes. Another option was to sell all power generated to QC at the border without controlling its transmission (Feehan, 2011). Otherwise, the development of hydropower plant was at risk of cancelling. QC, on the other hand, could sign an agreement based on proposals from Brinco, or delay its signing. It is noteworthy to mention that this stage of the negotiations came after a letter of intent was signed between Brinco and QC.

The twelve feasible states are shown across the top of Table 6.2. The preferences of DMs are given in Table 6.3, ordered from most to least preferred, with some equally preferred states. For more information on how preferences of the DMs are constructed, see Section 3.3.1 (Matbouli et al., 2014b). Figure 6.5 shows the graph form for Brinco. Nodes in the graph indicate the states and the unilateral moves available to Brinco. In Figure 6.5 there are two groups of nodes. The group on the left side, are the consequence if the investors choose not to finance Brinco's choices. On the right side, the nodes represent the agreement if the investors choose to finance Brinco. Moves between the two groups by

the investors are possible, as shown in Figure 6.7. Within each group, Brinco can make different selections, but if QC is involved, a deal can be reached only if QC agrees to sign, as shown in Figure 6.6. Brinco, however, has a unilateral move available from both groups of nodes, which is to cancel the project.

Table 6.1: Decision Makers, Binary Options, and Option Levels

DMs	Options	Short Form	Option Levels
Brinco	Sell to Québec	STQC	{Y, N}
	Transmit via Québec	TVQC	{Y, N}
	Transmit via Maritime Route	TVM	{Y, N}
	Call off	-	{Y, N}
QC	Sign	-	{Y, N}
	Delay	-	{Y, N}
Investors	Finance	-	{Y, N}

Table 6.2: Decision Makers, Options, and Outcomes for Churchill Falls Contract Negotiations

DMs	Options	States											
		1	2	3	4	5	6	7	8	9	10	11	12
Brinco	STQC	N	Y	N	N	Y	N	N	Y	N	N	Y	N
	TVQC	Y	N	N	Y	N	N	Y	N	N	Y	N	N
	TVM	N	N	Y	N	N	N	N	N	Y	N	N	N
	Call off	N	N	N	N	N	Y	N	N	N	N	N	Y
QC	Sign	Y	Y	-	N	N	-	Y	Y	-	N	N	-
	Delay	N	N	-	Y	Y	-	N	N	-	Y	Y	-
Investors	Finance	N	N	N	N	N	N	Y	Y	Y	Y	Y	Y

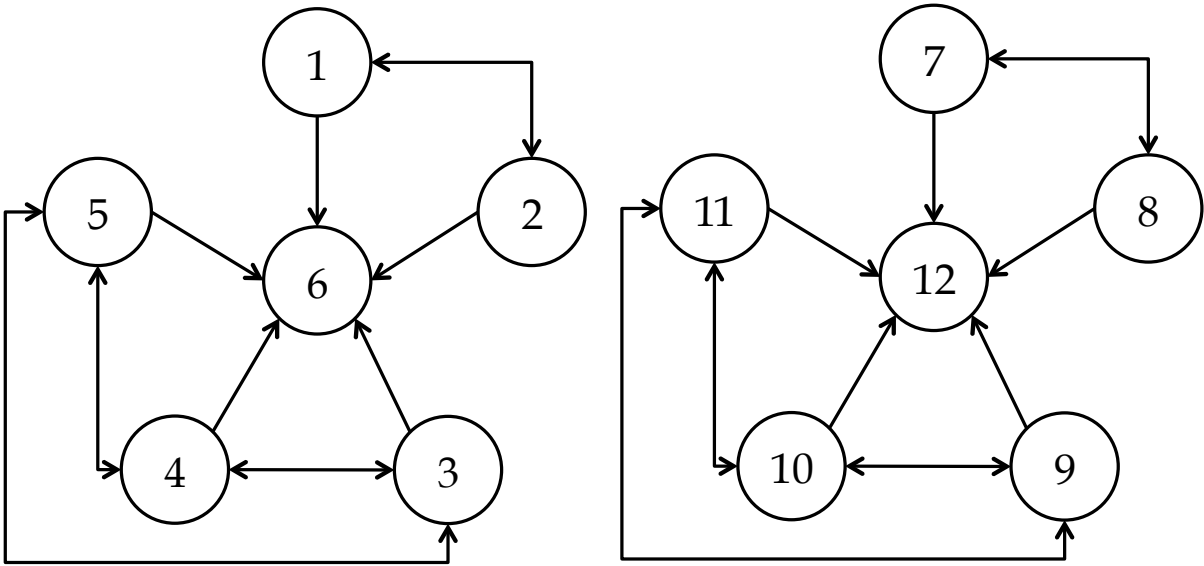

Figure 6.5: Graph Form for Brinco with Binary Options

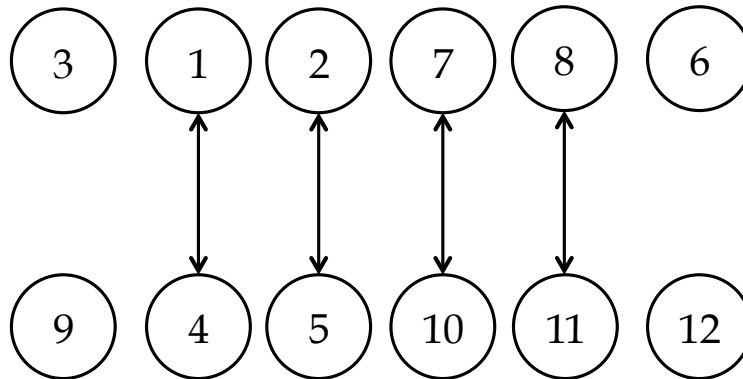

Figure 6.6: Graph Form for Québec

Table 6.3: Decision Makers' Preferences Ranking over Outcomes of Binary Options

DMs	Preference Ranking
Brinco	$7 \succ 8 \succ 9 \succ 11 \succ 10 \succ 12 \succ 6 \succ 1 \sim 2 \sim 3 \sim 4 \sim 5$
QC	$8 \succ 2 \succ 3 \sim 4 \succ 6 \succ 5 \sim 11 \succ 10 \sim 12 \succ 1 \sim 7 \succ 9$
Investors	$7 \sim 8 \succ 1 \sim 2 \succ 3 \sim 4 \sim 5 \sim 6 \sim 10 \succ 9 \sim 11 \succ 12$

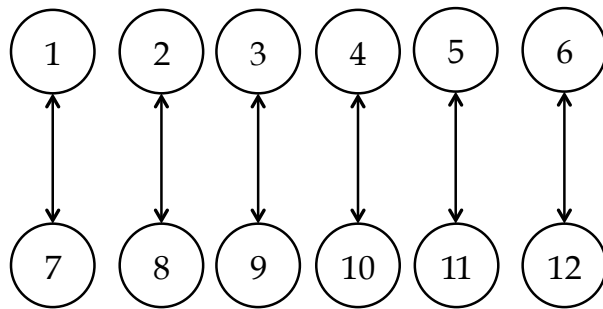

Figure 6.7: Graph Form for Investors

6.3.2 Analysis of Binary Options Model

Stability analysis based on Nash and sequential stability (SEQ) (Nash, 1950, 1951; Fraser and Hipel, 1979, 1984), gives the equilibrium states for the binary options model shown in Table 6.4. There are four equilibria. At state 6, the equilibrium represents the situation when Brinco decides to cancel the development. At states 7 and 8, QC agrees to sign a proposal by Brinco to transmit power via Québec and sell to Québec respectively. State 9, on the other hand, represents the outcome that the investors agree to finance the power transmission line via the Maritimes.

Table 6.4: Equilibrium States for Binary Options Model

DMs	Options	Equilibrium States			
		6	7	8	9
Brinco	STQC	N	N	Y	N
	TVQC	N	Y	N	N
	TVM	N	N	N	Y
	Call off	Y	N	N	N
QC	Sign	-	Y	Y	-
	Delay	-	N	N	-
Investors	Finance	N	Y	Y	Y

6.3.3 Modelling with Multi-Level Options

Looking back at the DMs' options in Table 6.1, there is an opportunity to represent one of Brinco's options as multi-level, as now proposed in Table 6.5. The original binary option for Brinco is to offer to sell all power generated from the Churchill Falls hydropower plant to QC at the border. But if this option is selected, the sale price may have several levels, high, average, or low, relative to the market price at the time. These price levels were not considered in the original binary options model. Strategies that can be selected for each option now have multiple levels, as summarized in Table 6.5.

In the original formulation of this model, there was a difficulty in describing Brinco's preferences, because Brinco appeared to prefer the sale of power to QC over transmitting via Maritimes (see Table 6.3). However, later in the conflict NL started to work on building a Maritimes transmission link to reach buyers beyond QC. This preference was difficult to capture in the original model because Brinco's preferences in regard to selling the power to QC versus transmitting it directly to the buyers depend on the price it receives from QC for the sale. If the price represents the market price, Brinco will prefer to sell to QC rather

than building an expensive transmission line. However, if the price was significantly less than market value, then Brinco, and later NL as it took over full control of Brinco, could prefer to select the expensive and challenging Maritimes route (see the new preference ranking in Table 6.7).

Brinco's offer of sale to QC now becomes a multi-level option with $k = 4$. The levels depend on the price offer: high (h), average (a), or low (l).

Table 6.6 gives the multi-level option negotiations model. The number of feasible states has increased from 12 to 20, because each occurrence of sale in the option form is now replaced with three levels, instead of one. Looking at the preferences of Brinco in Table 6.3 in comparison to Table 6.7 produces some interesting insights. Brinco would prefer to sell power to QC rather than choose the expensive Maritimes route only when the sale price is high or average. This important feature of preference was absent in the original model of Table 6.3. Hence, this information at the modelling stage helps explain why this conflict evolved in future rounds. The market price of hydropower surged dramatically following the signing of the final contract between Brinco and QC. As a result, the sale price became very low compared to the market price, which motivated NL to change its strategy when it came to developing the remaining hydropower potential of the Churchill River (See (Matbouli et al., 2014b)). This valuable insight strengthens the model because it demonstrates the possibility of future evolution of the original conflict, which does not appear without multi-level options. Utilizing such options not only makes preferences more expressive of reality, but also facilitates the understanding of possible future rounds of the conflict.

Figure 6.8 shows the moves available to Brinco considering multi-level options. There are multiple nodes drawn at states 2, 5, 8 and 11. Each of these states now represents a group of nearby states that differ only in the levels of the selling price.

Table 6.5: Decision Makers, Multi-Level Options and Selection Levels

DMs	Options	Number of Levels	Option Levels
Brinco	STQC	$L(o) = 4$	$\{h, a, l, N\}$
	TVQC	$L(o) = 2$	$\{Y, N\}$
	TVM	$L(o) = 2$	$\{Y, N\}$
	Call off	$L(o) = 2$	$\{Y, N\}$
QC	Sign	$L(o) = 2$	$\{Y, N\}$
	Delay	$L(o) = 2$	$\{Y, N\}$
Investors	Finance	$L(o) = 2$	$\{Y, N\}$

Table 6.6: Decision Makers, Multi-Level Options, and Outcomes

DMs	Options	States																			
		1	2	3	4	5	6	7	8	9	10	11	12	13	14	15	16	17	18	19	20
		1	2.1	2.2	2.3	3	4	5.1	5.2	5.3	6	7	8.1	8.2	8.3	9	10	11.1	11.2	11.3	12
Brinco	STQC	N	<i>h</i>	<i>a</i>	<i>l</i>	N	N	<i>h</i>	<i>a</i>	<i>l</i>	N	N	<i>h</i>	<i>a</i>	<i>l</i>	N	N	<i>h</i>	<i>a</i>	<i>l</i>	N
	TVQC	Y	N	N	N	N	Y	N	N	N	N	Y	N	N	N	N	Y	N	N	N	N
	TVM	N	N	N	N	Y	N	N	N	N	N	N	N	N	N	Y	N	N	N	N	N
	Call off	N	N	N	N	N	N	N	N	N	Y	N	N	N	N	N	N	N	N	N	Y
QC	Sign	Y	Y	Y	Y	-	N	N	N	N	-	Y	Y	Y	Y	-	N	N	N	N	-
	Delay	N	N	N	N	-	Y	Y	Y	Y	-	N	N	N	N	-	Y	Y	Y	Y	-
Investors	Finance	N	N	N	N	N	N	N	N	N	N	Y	Y	Y	Y	Y	Y	Y	Y	Y	Y

6.3.4 Analysis of the Multi-Level Options Model

Equilibrium states that result from the analysis of the multi-level option model are listed in Table 6.8. Some of the equilibria can be compared to the equilibria of the binary option model. However, there are two new equilibria, at states 13 and 14, both in which Brinco’s offer of sale of power to QC is accepted and the investors agree to finance. States 13 and 14 are nearby states differing only in the selling price, which is average at state 13 and low at state 14. These two nearby equilibria provides an interesting insights on the possibility of

Table 6.7: Decision Makers' Preferences Ranking over Outcomes of Multi-Level Options

DMs	Preference Ranking
Brinco	12 \succ 13 \succ 11 \succ 15 \succ 16 \sim 17 \sim 18 \sim 19 \sim 20 \succ 14 \succ 10 \succ 1 \sim 2 \sim 3 \sim 4 \succ 5 \sim 6 \sim 7 \sim 8 \sim 9
QC	14 \succ 4 \succ 19 \succ 9 \succ 5 \sim 6 \sim 8 \succ 10 \succ 7 \succ 16 \sim 17 \sim 18 \succ 20 \succ 1 \sim 3 \sim 11 \sim 13 \sim 15 \succ 2 \sim 12
Investors	12 \succ 11 \sim 13 \succ 14 \succ 2 \succ 1 \sim 3 \succ 4 \succ 5 \sim 6 \sim 7 \sim 8 \sim 9 \sim 10 \sim 15 \succ 16 \sim 17 \sim 18 \sim 19 \succ 20

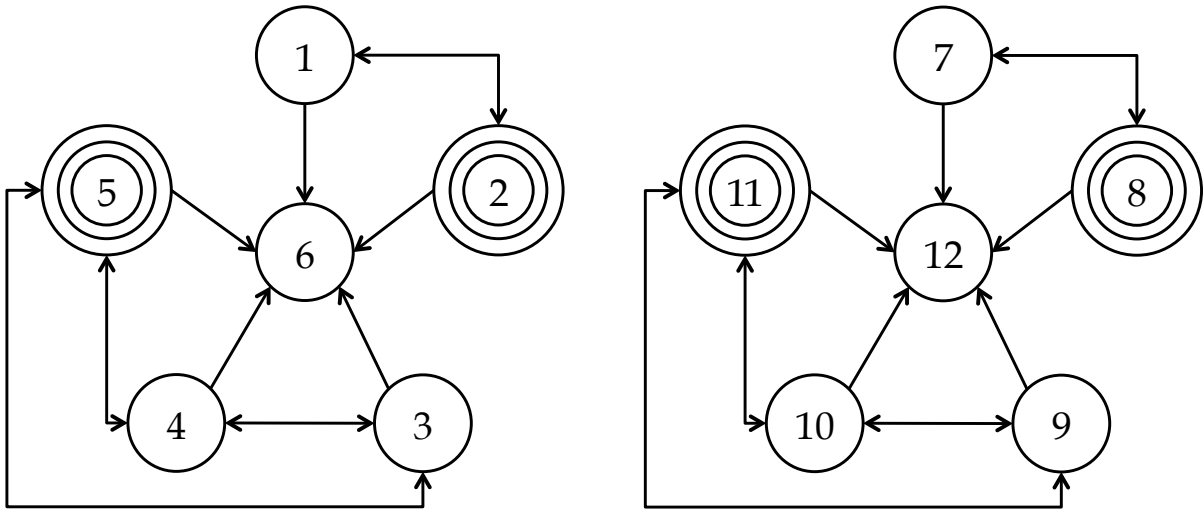

Figure 6.8: Graph Form for Brinco with Multi-Level Options

evolution of the conflict. If the conflict were to evolve, it could be because a DM, Brinco in this case, is trying to reach a nearby equilibrium, which is considered an improvement on the level of the selling price.

6.4 Conclusions

Options are a useful approach to conflict resolution modelling because they represent possible courses of actions of each DM. The original structure of options in the graph model is

Table 6.8: Equilibrium States for Multi-Level Options Model

DMs	Options	Equilibrium States				
		10	11	13	14	15
		6	7	8.2	8.3	9
Brinco	STQC	N	N	<i>a</i>	<i>l</i>	N
	TVQC	N	Y	N	N	N
	TVM	N	N	N	N	Y
	Call off	Y	N	N	N	N
QC	Sign	-	Y	Y	Y	-
	Delay	-	N	N	N	-
Investors	Finance	N	Y	Y	Y	Y

described in terms of binary options—the DM must chose either to select or not to select an option. However, it is natural to think that a DM considering an option may select a partial move toward the full option. DMs can bargain about how much each DM is willing to offer or need to receive in order to reach a compromise. The multi-level option structure, as proposed in this chapter, is very useful in expressing the problem as DMs see it. Conditional preferences can be easily represented. Moreover, some strategic insights can be gained in the analysis of multi-level options model. It is possible for the analyst to detect possible nearby equilibria that will facilitate the understanding of conflict evolution. Furthermore, using multi-level options provides an opportunity to analyze a DM strategic selection of moves that will led him or her to a transitional equilibrium, in order to make a more preferred outcome accessible.

6.5 Chapter Summary

An expansion to the options structure is proposed to make the option-based graph model for conflict resolution more explicitly expressive of reality. The suggested improvement provides an opportunity to replace binary (on or off) options with multi-level options, wherein the decision maker (DM) selects one out of more than two distinct levels. The new approach simplifies the representation of conflicts and facilitates the understanding of their evolution by showing, in negotiations for example, outcomes that involve partial achievement of a DM's objectives. The preferences of decision makers can now be related to the possibility of tradeoffs between (or among) options.

Chapter 7

Conclusions and Future Research

In this thesis, a number of challenges in the modelling and analysis of sustainable conflict resolution are addressed. The contributions to making conflict resolution sustainable are summarized according to modelling and analysis.

7.1 Modelling for Sustainable Conflict Resolution

7.1.1 Characterization of a Conflict

Looking at a single round of a conflict, in isolation from prior and future conflict, can obscure the general picture of a conflict, making it hard to model. A framework for the characterization of a conflict is proposed in order to capture relevant information about a real world conflict. An analyst can now systematically study a conflict with emphasis on its first round. Using the characterization stages can help highlight situations in which a conflict exists but is dormant. A dormant conflict is not a resolved conflict, but is in a period that precedes an active round. Proactive conflict resolution intervention

should take advantage of this stage before an active conflict begins. The need for conflict characterization is exemplified by the Great Canadian Hydroelectric Power conflict, which progressed throughout multiple rounds.

7.1.2 The Preference Graph Model for Conflict Resolution

The Graph Model for Conflict Resolution (GMCR) is a flexible modelling technique for formally investigating conflicts with any number of DMs. The ability to represent different types of moves gives the graph model an advantage over other modelling schemes. Having the preferences of DMs represented on the graph makes the graph model even more useful. Such enhancements to the graph model makes interpretation of two important stability concepts possible by looking at the graph. Moreover, embedding the preferences into the graph portion of the model assists an analyst in understanding the direction of a DM moves, even when there is no available move. This is possible because a desired move that is not available unilaterally may be an opportunity for forming a coalition.

7.1.3 Multi-Level Options

One modelling limitation that appeared when applying the original graph model to the Great Canadian Hydroelectric Power conflict is the inaccuracy of describing the preferences. Brinco would prefer selling power to QC over transferring power via the Maritimes route when sale price reflects market value. Different levels of the offer to sell are not visible without the structure of multi-level options. The expansion of options facilitates the representation of important information about a DM's available actions and preferences. As well, the introduction of multi-level options makes options representation more natural by representing strategies selections of options that are not necessarily binary.

7.2 Analysis for Sustainable Conflict Resolution

When analyzing a conflict using the graph model, it is not uncommon to have more than one equilibrium. Robustness of equilibria in the graph model, a new concept, is an approach to assessing equilibrium sustainability. The Level of Freedom concept enables the analyst to rank equilibria based on their robustness. This provides an interesting insight into the resiliency of an equilibrium against deviation for conflict resolution purposes.

Moreover, analysis of nearby equilibrium states, which could result from a multi-level option model, provides strategic insights into the possibility of a transitional resolution. DMs could challenge an equilibrium not only to achieve a different objective, but sometimes to improve on an equilibrium that is only partially satisfactory.

7.3 Ideas for Future Research

Research in conflict resolution modelling and analysis using systematic approaches is limited, so there are many opportunities to contribute to this field. Each chapter of this thesis, especially Chapters 5 and 6, provides foundations to a new research direction for the graph model. The introduction of multi-level options is new and could be further expanded to handle complex structures of preferences. It can also be used to model dynamic changes during the course of a conflict. Furthermore, multi-level options may enable analysis of bargaining and trade-offs without using quantitative utility values to indicate preferences.

Robustness of equilibria is an important direction that requires further research. Improvements to definitions of robustness of equilibria and new ways to measure it are needed to detect the likelihood of having a temporary equilibrium. Moreover, the methodologies proposed in this thesis are applied to graph models with complete information. There is an

opportunity to develop and utilize probability theory, fuzzy logic, grey numbers, and hypergames, in order to account for uncertainty and misperception in modelling and analysis. In addition, the definition of Level of Freedom could be revised to define different classes of Level of Freedom considering the foresight of DMs. For example, one could investigate the freedom of a DM to move considering one step, two steps, or n-steps into future.

As well, conflict characterization could also be further developed. For example, one could use Stakeholder Identification and Influence Theory (Mitchell et al., 1997; Frooman, 1999) to identify DMs in a conflict and their degrees of involvement. Furthermore, the graphical representation of a model could be further enhanced to make preferences more easily read and strategic behaviours easier to understand.

7.4 Publications During PhD Studies

In this section, the author of the thesis would like to present the list of papers published or accepted during his PhD program at the University of Waterloo. Most of the following refereed journal and conference papers have been integrated into the writing of this thesis:

7.4.1 Journal Papers

1. Matbouli, Y. T., Hipel, K. W., and Kilgour, D. M. (2014b). Strategic analysis of the Great Canadian Hydroelectric power conflict. *Energy Strategy Reviews*, 4(0):43 – 51.
2. Matbouli, Y. T., Hipel, K. W., Kilgour, D. M., and Karray, F. (2014c). A fuzzy logic approach to assess, manage, and communicate carcinogenic risk. *Human and Ecological Risk Assessment: An International Journal*, 20(6):1687–1707.

3. Matbouli, Y. T., Kilgour, D. M., and Hipel, K. W. (2015c). Robustness of equilibrium in the graph model for conflict resolution. *Systems Science and Systems Engineering*. Accepted for publication on October 8, 2015

7.4.2 Conference Papers

Full Papers

4. Matbouli, Y. T., Hipel, K. W., and Kilgour, D. M. (2015a). Introducing multi-level options to the graph model of conflict resolution. In *Systems, Man, and Cybernetics (SMC), 2015 IEEE International Conference on*, City University of Hong Kong, Hong Kong, Just Accepted
5. Matbouli, Y. T., Hipel, K. W., and Kilgour, D. M. (2014a). A fresh perspective on robustness of equilibrium in the graph model. In *Systems, Man, and Cybernetics (SMC), 2014 IEEE International Conference on*, pages 2936–2941, Paradise Point Resort and Spa, San Diego, CA, USA.
6. Matbouli, Y. T., Hipel, K. W., and Kilgour, D. M. (2013a). Characterization of a conflict. In *Systems, Man, and Cybernetics (SMC), 2013 IEEE International Conference on*, pages 2050 – 2054, Midland Hotel, Manchester, United Kingdom.
7. Matbouli, Y. T., Hipel, K. W., and Kilgour, D. M. (2012b). The Upper Churchill Falls development negotiations. In *Systems, Man, and Cybernetics (SMC), 2012 IEEE International Conference*, pages 2762–2767, COEX (Convention and Exhibition Center), Seoul, Korea.

Extended Abstracts

8. Matbouli, Y. T., Hipel, K. W., and Kilgour, D. M. (2015b). Multi-level options in the graph model for conflict resolution. In Kamiński, B., Kersten, G., Szufel, P., Jakubczyk, M., and Wachowicz, T., editors, *The 15th International Conference on Group Decision & Negotiation Letters*, pages 253–256, Warsaw School of Economics, Warsaw, Poland. Warsaw School of Economics Press.
9. Matbouli, Y. T., Kilgour, D. M., and Hipel, K. W. (2014d). The preference graph model for conflict resolution. In Zaraté, P., Camilleri, G., Kamissoko, D., and Amblard, F., editors, *Group Decision and Negotiation – GDN 2014 Proceedings of the Joint International Conference of the INFORMS GDN Section and the EURO Working Group on DSS*, pages 244–249, University Toulouse 1 Capitole, Toulouse, France. Toulouse University.
10. Matbouli, Y. T., Hipel, K. W., and Kilgour, D. M. (2013c). Robustness of equilibrium in conflict resolution. In *Group Decision and Negotiation – GDN 2013*, pages 52–53, Department of Computer and Systems Sciences (DSV), Stockholm University, Stockholm, Sweden.
11. Matbouli, Y. T., Hipel, K. W., and Kilgour, D. M. (2013b). Evolution of the Great Canadian Hydroelectric conflict. In *6th International Conference on Water Resources and Environment Research (ICWRER2013)*, Rhein-Mosel-Halle, Koblenz, Germany.
12. Matbouli, Y. T., Hipel, K. W., and Kilgour, D. M. (2012a). The Great Canadian Hydroelectric Power conflict: Contract negotiations. In de Almeida, A. T., Morais, D. C., and de Franca Dantas Daher, S., editors, *Group Decision and Negotiation 2012 Conference (GDN 2012)*, volume I, pages 96–99, Golden Tulip Recife Palace Hotel, Recife, Pernambuco, Brazil.

7.5 Chapter Summary

Finally, as indicated in the title of this thesis “Sustainable Conflict Resolution: Modelling, Analysis, and Strategic Insights”, a number of proposed methodologies to provide insights into the evolution and resolution of conflicts have been put forward. To explain why an equilibrium may change has been addressed using the characterization of a conflict, robustness of equilibria, and analysis of nearby states using multi-level options. The analyst may choose what kind of approach to use in a potential case study. These proposed methodologies are general and can be applied to conflicts arising in different fields, such as engineering, business, and international affairs. Although all of the proposed methodologies can be integrated to analyze a long-term conflict, each method can be separately used without the others. An analyst may choose to apply the robustness of equilibria measure and not multi-level options, and vice versa. However, the characterization of a conflict, is always relevant, and can provide input parameters to a conflict resolution model. Preference graphics are also a useful tool for the presentation of a conflict to DMs, in order to furnish a sense of possible directions of a conflict.

References

- Abadie, A. and Gardeazabal, J. (2003). The economic costs of conflict: A case study of the Basque Country. *American Economic Review*, 93(1):113–132.
- Al-Mutairi, M. S., Hipel, K. W., and Kamel, M. S. (2008). Fuzzy preferences in conflicts. *Journal of Systems Science and Systems Engineering*, 17(3):257–276.
- Allison, G. T. (1969). Conceptual models and the Cuban missile crisis. *The American Political Science Review*, 63(3):689–718.
- Amos, S. (1880). *Political and Legal Remedies for War*. Harper & Brothers, Franklin Square, New York.
- Bashar, M. A., Kilgour, D. M., and Hipel, K. W. (2012). Fuzzy preferences in the graph model for conflict resolution. *Fuzzy Systems, IEEE Transactions on*, 20(4):760–770.
- Bernath Walker, S., Hipel, K. W., and Inohara, T. (2009). Strategic decision making for improved environmental security: coalitions and attitudes. *Journal of Systems Science and Systems Engineering*, 18(4):461–476.
- Brams, S. and Wittman, D. (1981). Nonmyopic equilibria in 2×2 games. *Conflict Management and Peace Science*, 6(1):39–62.

- CBC News (2011). Developing the Lower Churchill: A \$6.2 billion project. News report. <http://www.cbc.ca/news/canada/developing-the-lower-churchill-a-6-2-billion-project-1.975868>, accessed December 2011.
- Charness, G., Cobo-Reyes, R., and Jiménez, N. (2008). An investment game with third-party intervention. *Journal of Economic Behavior and Organization*, 68(1):18 – 28.
- Churchill, J. L. (2003). Royal Commission on Renewing and Strengthening Our Place in Canada, Power Politics and Questions of Political Will: A History of Hydroelectric Development in Labrador’s Churchill River Basin, 1949-2002. Report, Cleo Research Associates. <http://www.gov.nf.ca/publicat/royalcomm/research/Churchill.pdf>, accessed March 2012.
- Cranna, M. and Bhinda, N. (1994). *The True Cost of Conflict*. New Press, New York.
- Department of Justice, Canada (1983). A Consolidation of the Constitution Acts 1867 to 1982. *Ottawa, ON: Supply and Services Canada*.
- Fang, L., Hipel, K. W., and Kilgour, D. M. (1993). *Interactive Decision Making: the Graph Model for Conflict Resolution*. Wiley, New York.
- Feehan, J. P. (2011). Smallwood, Churchill Falls, and the power corridor through Québec. *Acadiensis: Journal of the History of the Atlantic Region*, 40(2):112–127.
- Feehan, J. P. and Baker, M. (2007). The origins of a coming crisis: Renewal of the Churchill Falls contract. *Dalhousie Law Journal*, 30:207.
- Fraser, N. M. and Hipel, K. W. (1979). Solving complex conflicts. *Systems, Man and Cybernetics, IEEE Transactions on*, 9(12):805–816.

- Fraser, N. M. and Hipel, K. W. (1983). Dynamic analysis of the Cuban missile crisis. *Conflict Management and Peace Science*, 6(2):1–18.
- Fraser, N. M. and Hipel, K. W. (1984). *Conflict Analysis: Models and Resolutions*, volume 11. North-Holland, New York.
- Frooman, J. (1999). Stakeholder influence strategies. *Academy of Management Review*, 24(2):191–205.
- Fudenberg, D., Kreps, D. M., and Levine, D. K. (1988). On the robustness of equilibrium refinements. *Journal of Economic Theory*, 44(2):354 – 380.
- Galtung, J. (2008). Conflict Theory. In Kurtz, L., editor, *Encyclopedia of Violence, Peace, and Conflict*, pages 391 – 400. Academic Press, Oxford, second edition.
- Government of Newfoundland and Labrador (2010). Quebec’s Refusal of Transmission Access Once Again Demonstrates Its Arrogance and Discriminatory Business Practices. Technical report. <http://www.releases.gov.nl.ca/releases/2010/exec/0512n09.htm>, accessed November 2011.
- Hauteclouque, A. D. and Glachant, J.-M. (2009). Long-term energy supply contracts in European competition policy: Fuzzy not crazy. *Energy Policy*, 37(12):5399 – 5407.
- Hess, G. (2003). The economic welfare cost of conflict: an empirical assessment. Technical report, Center for Economic Studies and Ifo Institute for Economic Research, The Robert Day School of Economics and Finance, Claremont McKenna College.
- Hipel, K. W. (1992a). Multiple objective decision making in water resources. *JAWRA Journal of the American Water Resources Association*, 28(1):3–12.

- Hipel, K. W., editor (1992b). *Multiple Objective Decision Making in Water Resources*, volume 28 of *AWRA Monograph Series No. 18*. American Water Resources Association.
- Hipel, K. W., editor (2009a). *Conflict Resolution*, volume 1. Eolss Publisher, Oxford, UK.
- Hipel, K. W., editor (2009b). *Conflict Resolution*, volume 2. Eolss Publisher, Oxford, UK.
- Hipel, K. W., Fang, L., Kilgour, D. M., and Haight, M. (1993). Environmental conflict resolution using the graph model. In *Systems, Man and Cybernetics, 1993. 'Systems Engineering in the Service of Humans', Conference Proceedings., International Conference on*, pages 153–158 vol.1. IEEE.
- Hipel, K. W., Kilgour, D. M., and Fang, L. (2011). The graph model for conflict resolution. *Wiley Encyclopedia of Operations Research and Management Science*, 3:2099–2111.
- Hipel, K. W., Kilgour, D. M., Fang, L., and Peng, X. J. (1997). The decision support system GMCR in environmental conflict management. *Applied Mathematics and Computation*, 83(2–3):117 – 152.
- Hipel, K. W. and Obeidi, A. (2005). Trade versus the environment: Strategic settlement from a systems engineering perspective. *Systems Engineering*, 8(3):211–233.
- Howard, N. (1971). *Paradoxes of Rationality: Games, Metagames, and Political Behavior*. MIT Press, Cambridge, Massachusetts.
- Hydro-Québec and Churchill Falls (Labrador) Corporation Limited (1969). Power Contract Between Quebec Hydro-Electric Commission and Churchill Falls (Labrador) Corporation Limited, May 12, 1969. Contract. http://www.bibliotheque.assnat.qc.ca/DepotNumerique_v2/AffichageFichier.aspx?idf=126620, accessed November 2011.

- Inohara, T. and Hipel, K. W. (2008a). Coalition analysis in the graph model for conflict resolution. *Systems Engineering*, 11(4):343–359.
- Inohara, T. and Hipel, K. W. (2008b). Interrelationships among noncooperative and coalition stability concepts. *Journal of Systems Science and Systems Engineering*, 17(1):1–29.
- Jeong, H.-W., Lerche, C., and Susnjic, S. (2008). Conflict Management and Resolution. In Kurtz, L., editor, *Encyclopedia of Violence, Peace, and Conflict*, pages 379 – 390. Academic Press, Oxford, second edition.
- Johnston, A., Kavali, A., and Neuhoff, K. (2008). Take-or-pay contracts for renewables deployment. *Energy Policy*, 36(7):2481 – 2503.
- Judicial Committee of Great Britain Privy Council (1927). *In the matter of the boundary between the Dominion of Canada and the Colony of Newfoundland in the Labrador Peninsula*. London, Printed by W. Clowes and Sons,.
- Keeney, R. L. (1992). *Value-Focused Thinking: A Path to Creative Decision Making*. Harvard University Press, Cambridge, MA, USA.
- Kilgour, D. M. (1984). Equilibria for far-sighted players. *Theory and Decision*, 16(2):135–157.
- Kilgour, D. M. (1985). Anticipation and stability in two-person noncooperative games. *Dynamic Models of International Conflict*, pages 26–51.
- Kilgour, D. M. and Eden, C., editors (2010). *Handbook of Group Decision and Negotiation*, volume 4. Springer, New York.
- Kilgour, D. M. and Hipel, K. W. (2005). The graph model for conflict resolution: Past, present, and future. *Group Decision and Negotiation*, 14:441–460.

- Kilgour, D. M., Hipel, K. W., and Fang, L. (1987). The graph model for conflicts. *Automatica*, 23(1):41 – 55.
- Kilgour, D. M., Hipel, K. W., Fang, L., and Peng, X. (2001). Coalition analysis in group decision support. *Group Decision and Negotiation*, 10(2):159–175.
- Kohlberg, E. and Mertens, J. (1986). On the strategic stability of equilibria. *Econometrica: Journal of the Econometric Society*, 54(5):1003–1037.
- Kuhn, H. (1953). Extensive games and the problem of information. *Contributions to the Theory of Games*, 2(28):193–216.
- Lewicki, R. J., Weiss, S. E., and Lewin, D. (1992). Models of conflict, negotiation and third party intervention: A review and synthesis. *Journal of Organizational Behavior*, 13(3):209–252.
- Li, K. W., Kilgour, D. M., and Hipel, K. W. (2004). Status quo analysis of the Flathead river conflict. *Water Resources Research*, 40(5):W05S03.
- Matbouli, Y. T., Hipel, K. W., and Kilgour, D. M. (2012a). The Great Canadian Hydroelectric Power conflict: Contract negotiations. In de Almeida, A. T., Morais, D. C., and de Franca Dantas Daher, S., editors, *Group Decision and Negotiation 2012 Conference (GDN 2012)*, volume I, pages 96–99, Golden Tulip Recife Palace Hotel, Recife, Pernambuco, Brazil.
- Matbouli, Y. T., Hipel, K. W., and Kilgour, D. M. (2012b). The Upper Churchill Falls development negotiations. In *Systems, Man, and Cybernetics (SMC), 2012 IEEE International Conference*, pages 2762–2767, COEX (Convention and Exhibition Center), Seoul, Korea.

- Matbouli, Y. T., Hipel, K. W., and Kilgour, D. M. (2013a). Characterization of a conflict. In *Systems, Man, and Cybernetics (SMC), 2013 IEEE International Conference on*, pages 2050 – 2054, Midland Hotel, Manchester, United Kingdom.
- Matbouli, Y. T., Hipel, K. W., and Kilgour, D. M. (2013b). Evolution of the Great Canadian Hydroelectric conflict. In *6th International Conference on Water Resources and Environment Research (ICWRER2013)*, Rhein-Mosel-Halle, Koblenz, Germany.
- Matbouli, Y. T., Hipel, K. W., and Kilgour, D. M. (2013c). Robustness of equilibrium in conflict resolution. In *Group Decision and Negotiation – GDN 2013*, pages 52–53, Department of Computer and Systems Sciences (DSV), Stockholm University, Stockholm, Sweden.
- Matbouli, Y. T., Hipel, K. W., and Kilgour, D. M. (2014a). A fresh perspective on robustness of equilibrium in the graph model. In *Systems, Man, and Cybernetics (SMC), 2014 IEEE International Conference on*, pages 2936–2941, Paradise Point Resort and Spa, San Diego, CA, USA.
- Matbouli, Y. T., Hipel, K. W., and Kilgour, D. M. (2014b). Strategic analysis of the Great Canadian Hydroelectric power conflict. *Energy Strategy Reviews*, 4(0):43 – 51.
- Matbouli, Y. T., Hipel, K. W., and Kilgour, D. M. (2015a). Introducing multi-level options to the graph model of conflict resolution. In *Systems, Man, and Cybernetics (SMC), 2015 IEEE International Conference on*, City University of Hong Kong, Hong Kong, Just Accepted.
- Matbouli, Y. T., Hipel, K. W., and Kilgour, D. M. (2015b). Multi-level options in the graph model for conflict resolution. In Kamiński, B., Kersten, G., Szufel, P., Jakubczyk, M., and Wachowicz, T., editors, *The 15th International Conference on Group Decision*

- É* *Negotiation Letters*, pages 253–256, Warsaw School of Economics, Warsaw, Poland. Warsaw School of Economics Press.
- Matbouli, Y. T., Hipel, K. W., Kilgour, D. M., and Karray, F. (2014c). A fuzzy logic approach to assess, manage, and communicate carcinogenic risk. *Human and Ecological Risk Assessment: An International Journal*, 20(6):1687–1707.
- Matbouli, Y. T., Kilgour, D. M., and Hipel, K. W. (2014d). The preference graph model for conflict resolution. In Zaraté, P., Camilleri, G., Kamissoko, D., and Amblard, F., editors, *Group Decision and Negotiation – GDN 2014 Proceedings of the Joint International Conference of the INFORMS GDN Section and the EURO Working Group on DSS*, pages 244–249, University Toulouse 1 Capitole, Toulouse, France. Toulouse University.
- Matbouli, Y. T., Kilgour, D. M., and Hipel, K. W. (2015c). Robustness of equilibrium in the graph model for conflict resolution. *Systems Science and Systems Engineering*. Accepted for publication on October 8, 2015.
- McEwen, A. C. (1982). The Labrador boundary. *Canadian Surveyor*, 36(2).
- Mehta, M. D. and Oullet, É., editors (1995). *Environmental Sociology Theory and Practice*. Captus Press Inc., North York, Ontario, Canada.
- Mitchell, R. K., Agle, B. R., and Wood, D. J. (1997). Toward a theory of stakeholder identification and salience: Defining the principle of who and what really counts. *Academy of Management Review*, 22(4):853–886.
- Myerson, R. (1978). Refinements of the Nash equilibrium concept. *International Journal of Game Theory*, 7(2):73–80.
- Nalcor Energy (2011a). Churchill Falls. Report, Nalcor Energy. <http://www.nalcorenergy.com/churchill-falls.asp>, accessed September 2015.

- Nalcor Energy (2011b). Lower Churchill Falls. Report, Nalcor Energy. <http://www.nalcorenergy.com/lower-churchill-project.asp>, accessed September 2015.
- Nash, J. (1950). Equilibrium points in n-person games. *Proceedings of the National Academy of Sciences*, 36(1):48–49.
- Nash, J. (1951). Non-cooperative games. *Annals of mathematics*, 54(2):286–295.
- Noakes, D., Fang, L., Hipel, K. W., and Kilgour, D. M. (2003). An examination of the salmon aquaculture conflict in British Columbia using the graph model for conflict resolution. *Fisheries Management and Ecology*, 10(3):123–137.
- Obeidi, A., Hipel, K., and Kilgour, D. (2005). The role of emotions in envisioning outcomes in conflict analysis. *Group Decision and Negotiation*, 14(6):481–500.
- Omosa, E. K. (2005). The impact of water conflicts on pastoral livelihoods: the case of Wajir district in Kenya. Technical report, International Institute for Sustainable Development, Winnipeg, MB, Canada.
- Ontario Power Generation (2012). Niagara Tunnel. Report, Ontario Power Generation. <http://www.opg.com/generating-power/hydro/projects/niagara-tunnel-project/Pages/niagara-tunnel-project.aspx>, accessed September 2015.
- Pieper, C. (2008). Decision theory and game theory. In Kurtz, L., editor, *Encyclopedia of Violence, Peace, and Conflict (Second Edition)*, pages 546 – 557. Academic Press, Oxford, second edition edition.
- Premier Danny Williams (2010). Giving speech at the Canadian Club of Ottawa. News release. http://www.releases.gov.nl.ca/releases/speeches/2010/canadianclub_speech.htm, accessed December 2011.

- Pye, R. (1978). A formal, decision-theoretic approach to flexibility and robustness. *The Journal of the Operational Research Society*, 29(3):pp. 215–227.
- Rapoport, A. (1974). *Fights, Games, and Debates*. A publication from the Center for Research on Conflict Resolution, The University of Michigan. University of Michigan Press.
- Rêgo, L. C. and Santos, A. M. (2013). Graph model for conflict resolution with stochastic preferences. In *Group Decision and Negotiation – GDN 2013*, pages 67–77, Department of Computer and Systems Sciences (DSV), Stockholm University, Stockholm, Sweden.
- Robinson, J. B. (1987). An embarrassment of riches: Canada’s energy supply resources. *Energy*, 12(5):379 – 402.
- Rosenhead, J., Elton, M., and Gupta, S. K. (1972). Robustness and optimality as criteria for strategic decisions. *Operational Research Quarterly*, 23(4):pp. 413–431.
- Rosenhead, J. and Mingers, J., editors (2001). *Rational Analysis for a Problematic World Revisited*. Wiley, Chichester, UK.
- Rosenhead, J. and Wiedemann, P. (1979). A note on robustness and interdependent decision making. *Journal of the Operational Research Society*, 30(9):833–834.
- Savich, P., Hipel, K. W., and Fraser, N. M. (1983). The Alaskan gas pipeline conflict. *Energy*, 8(3):213 – 224.
- Selten, R. (1975). Reexamination of the perfectness concept for equilibrium points in extensive games. *International Journal of Game Theory*, 4(1):25–55.
- Sheikhmohammady, M., Kilgour, D. M., and Hipel, K. W. (2010). Modeling the Caspian

- Sea negotiations. *Group Decision and Negotiation*, 19:149–168. 10.1007/s10726-008-9121-2.
- Smith, P. (1975). *Brinco : the story of Churchill Falls*. McClelland and Stewart, Toronto.
- The Supreme Court of Canada (1984). Reference re Upper Churchill water rights reversion act. (1 S.C.R. 297). <http://scc.lexum.org/en/1984/1984scr1-297/1984scr1-297.html>, accessed October 2012.
- The Supreme Court of Canada (1988a). Hydro-Québec v. Churchill Falls (Labrador) Corp. (1 S.C.R. 1087). <http://scc.lexum.org/en/1988/1988scr1-1087/1988scr1-1087.html>, accessed October 2012.
- The Supreme Court of Canada (1988b). Newfoundland (Attorney General) v. Churchill Falls (Labrador) Corp. (1 S.C.R. 1085). <http://scc.lexum.org/en/1988/1988scr1-1085/1988scr1-1085.html>, accessed October 2012.
- Ui, T. (2001). Robust equilibria of potential games. *Econometrica*, 69(5):1373–1380.
- Von Neumann, J. and Morgenstern, O. (1944). *Theory of Games and Economic Behavior (Commemorative Edition)*. Princeton University Press.
- Wang, M., Hipel, K. W., and Fraser, N. M. (1989). Solution concepts in hypergames. *Applied Mathematics and Computation*, 34(3):147–171.
- Willems, B. and Corte, E. D. (2008). Market power mitigation by regulating contract portfolio risk. *Energy Policy*, 36(10):3787 – 3796.
- Xianpei, Y., Hipel, K. W., and Lind, N. C. (1988). Conflict analysis of the LNG terminal siting dispute in the Netherlands. *Energy*, 13(9):725–737.

Zagare, F. (1984). Limited-move equilibria in 2×2 games. *Theory and Decision*, 16(1):1–19.

Zeng, D.-Z., Fang, L., Hipel, K. W., and Kilgour, D. M. (2004). Policy stable states in the graph model for conflict resolution. *Theory and Decision*, 57(4):345–365.