

Achieving Fairness in 802.11-Based
Multi-channel Wireless Mesh Networks

by

Ann Lee

A thesis

presented to the University of Waterloo

in fulfilment of the

thesis requirement for the degree of

Master of Applied Science

in

Electrical and Computer Engineering

Waterloo, Ontario, Canada, 2006

©Ann Lee 2006

Authors Declaration for Electronic Submission of a Thesis

I hereby declare that I am the sole author of this thesis. This is a true copy of the thesis, including any required final revisions, as accepted by my examiners.

I understand that my thesis may be made electronically available to the public.

Abstract

Multi-hop wireless networks based on 802.11 are being used more widely as an alternative technology for last-mile broadband Internet access. Their benefits include ease of deployment and lower cost. Such networks are not without problems. Current research on such networks aims at a number of challenges, including overcoming capacity limitation and poor fairness.

The focus of our research is for achieving fairness in multi-channel multi-hop wireless networks. First, we review the literature for different methods for representing link-contention areas, and the existing single-channel fairness computational model. Second, we generalize the fairness constraints applied to each link-contention area, defined in the existing single-channel fairness reference model, to multi-channel models. Third, by adopting the concepts of link-usage matrix and medium-usage matrix to represent network topology and flow status, and using Collision Domain theory and Clique Graph theory to represent link-contention area, we develop a computational model to compute optimal MAC-layer bandwidth allocated to each flow in a multi-channel multi-hop WMN. We simulate various network configurations to evaluate the performance of the fairness algorithm based on the above computational

model in different scenarios. We have found that in the multi-channel environment, our extension to the Collision Domain model generally provides a more accurate estimation of network capacity. Based on this model, we have extended the source-rate-limiting mechanism, which limits the flow rate to its fair share computed by the computational model. Experimental results that validate these findings are presented in this thesis.

Acknowledgments

First, I would like to thank my supervisor, Professor Paul Ward, for his great patience and encouragement during my graduate study here.

I need to thank my friends and colleagues Sheng Wang and Kamran Jamshaid for their big help during the past two years.

I thank my parents for encouraging me to never give up my academic goal.

Finally, I thank Glenn, for always drawing a nice picture in my life, and for always being there when I was frustrated.

Contents

1	Introduction	1
1.1	Motivations	6
1.1.1	Multi-channel Mesh Networks	11
1.2	Contribution	13
2	Background and Related Work	15
2.1	Definitions of Fairness	15
2.1.1	Absolute Fairness	16
2.1.2	Max-min Fairness	16
2.1.3	Proportional Fairness	18
2.2	Wireless Transmission Basics	18
2.3	The 802.11 Standard	20
2.3.1	The Effect of 802.11 on Fairness in WMNs	23

2.4	Fairness Constraints in Single-channel WMN	26
2.4.1	Clique-graph Theory	27
2.4.2	Collision-domain Theory	28
2.5	Related Work	30
2.5.1	Fairness Concepts	30
2.5.2	Fairness Implementations	33
3	Multi-channel WMN Capacity Models	36
3.1	Time Fairness in Single-channel Contention Area	37
3.2	Time Fairness in Single-channel WMN	43
3.3	Absolute Fairness in Single-channel WMN	49
3.4	Time Fairness in Multi-channel Contention Area	50
3.5	Time Fairness in Multi-channel WMN	52
3.6	Max-min Fairness	56
3.7	Model Validation	65
3.7.1	Chain Topology	68
3.7.2	Grid and Random Topologies	72
3.7.3	Statistical Analysis	73
3.7.4	Four-channel Scenarios	75
3.8	Generalized Max-min Fairness	77

3.8.1	Validation of Generalized Model	90
4	Achieving Fairness in Multi-channel WMN	107
5	Conclusion	118
5.1	Future Work	119

List of Tables

3.1 Accuracy Analysis for 3-Channel Networks: Lower Fair Share.	74
3.2 Accuracy Analysis for 3-Channel Networks: Higher Fair Share.	74
3.3 Accuracy Analysis for 4-Channel Networks: Lower Fair Share.	76
3.4 Accuracy Analysis for 4-Channel Networks: Higher Fair Share.	76
3.5 Accuracy Analysis for 4-Channel Networks: Lower Fair Share.	104
3.6 Accuracy Analysis for 4-Channel Networks: Higher Fair Share.	105

List of Figures

1.1	A Wireless Distribution System.	3
1.2	A Wireless Community Network.	4
1.3	WMN Architecture.	5
1.4	A Single-channel 5-Node Chain.	8
1.5	A Single-channel 3-Node Chain With 2 Streams.	11
1.6	Throughput Plot for Figure 1.5.	12
2.1	Transmission Range and Interference Range.	19
2.2	The Hidden Terminal Problem.	20
2.3	The Use of Virtual Sensing Using CSMA/CA.	23
2.4	A Chain Topology.	26
2.5	Contention Graph G for Scenario in Figure 2.1.	27
2.6	Collision Domain for Scenario in Figure 2.4.	28

3.1	A Simple WMN with Four Streams.	43
3.2	A Multi-channel WMN with Four Streams.	53
3.3	A Multi-channel WMN with Three Streams.	91
3.4	RCD and OCL Lower Fair Shares (for Chain Topology in Figure 3.3).	92
3.5	RCD Higher Fair Share (for Chain Topology in Figure 3.3).	93
3.6	Multi-channel Chain Topology.	93
3.7	Contention Graph G for Scenario in Figure 3.6.	94
3.8	Multi-channel Chain with RTS/CTS On.	94
3.9	3-Channel-2-Interface 5x5 Grid Topology.	95
3.10	RCD Higher Fair Share.	96
3.11	3-Channel-2-Interface Random Topology.	97
3.12	RCD Higher Fair Share.	98
3.13	4-Channel-2-Interface 6x4 Grid Topology.	98
3.14	RCD and OCL Lower Fair Shares.	99
3.15	OCL Higher Fair Share.	100
3.16	RCD Higher Fair Share.	101
3.17	A Multi-channel WMN with Three Streams.	102

3.18	4-Channel-2-Interface 5x4 Grid Topology.	103
3.19	RCD and OCL Lower Fair Shares.	104
3.20	OCL Higher Fair Share.	105
3.21	RCD Higher Fair Share.	106
4.1	4-Channel Chain Topology with 5 TCP Streams.	110
4.2	Simulation Results for Chain Topology (TCP) without Fairness Algorithm (for Figure 4.1).	110
4.3	Simulation Results for Chain Topology (TCP) with Fairness Algorithm (for Figure 4.1).	111
4.4	Simulation Results for A Single-channel Chain Topol- ogy (TCP) without Fairness Algorithm.	112
4.5	3-Channel Grid Topology with 8 TCP Streams.	115
4.6	Simulation Results for Grid Topology (TCP) without Fairness Algorithm (for Figure 4.5).	116
4.7	Simulation Results for Grid Topology (TCP) with Fair- ness Algorithm (for Figure 4.5).	117

Chapter 1

Introduction

With the widespread use of mobile devices such as laptop computers [13], cellular phones, and PDAs, wireless access to the Internet has become important. At present, this is achieved via a single wireless hop, either to base stations for cellular data, or to access points for wireless LAN access. However, it is expensive either to establish base stations or to install sufficient wired access points to ensure wireless coverage. An alternative solution is to form a multi-hop wireless network to allow users within an area to access the Internet.

The idea of multi-hop wireless networks has existed for over 30 years

[3], starting from packet radio network (1972), to survivable adaptive radio network (1980), and then to the global mobile information system and Ricochet networks [2](early 1990s). However, Mobile Ad Hoc Network (MANET) technology was not widely used until the IEEE 802.11 standard was adopted and 802.11 devices became widely available.

Multi-hop wireless networks exist in two forms, pure and impure. Pure MANETs make no assumption about infrastructure. That is, they can operate without power source other than battery, nodes may be mobile, and administrative domains may vary. However, applications for such networks are limited to either military or specialized civilian events, e.g., disaster recovery. Both have requirements far from common users' requirements.

By contrast, impure multi-hop wireless networks will make some assumptions about infrastructure. Such networks include Delay Tolerant Networks (DTNs), Wireless Mesh Networks (WMNs), Vehicular Ad Hoc Networks (VANETs), and Wireless Sensor Networks (WSNs). All relax, in one way or another, the strict requirement of pure MANETs. The focus of this thesis is WMNs, in which most users wish to connect to Internet, though some of

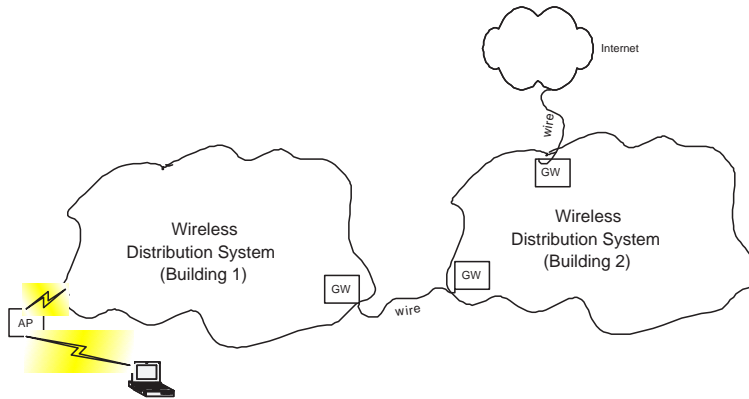

Figure 1.1: **A Wireless Distribution System.**

them are beyond transmission range of an access point. This happens where wireline Internet access and/or existing one-hop wireless access is too expensive to set up because of low utilization. In this situation, the stations have relatively fixed positions (within one room, for example), and are required to forward others' packets in a peer-to-peer mode, while they communicate to the Internet via a gateway [5] [14] [17]. In a WMN, cost is a significant issue and Internet access is a must.

WMNs operate in one of two typical scenarios, as shown in Figures 1.1 and 1.2. Figure 1.1 depicts a wireless distributed system of an 802.11 WLAN. Instead of being connected by wire, all stations can communicate via multi-hop wireless connection. The infrastructure cost can be greatly reduced as a

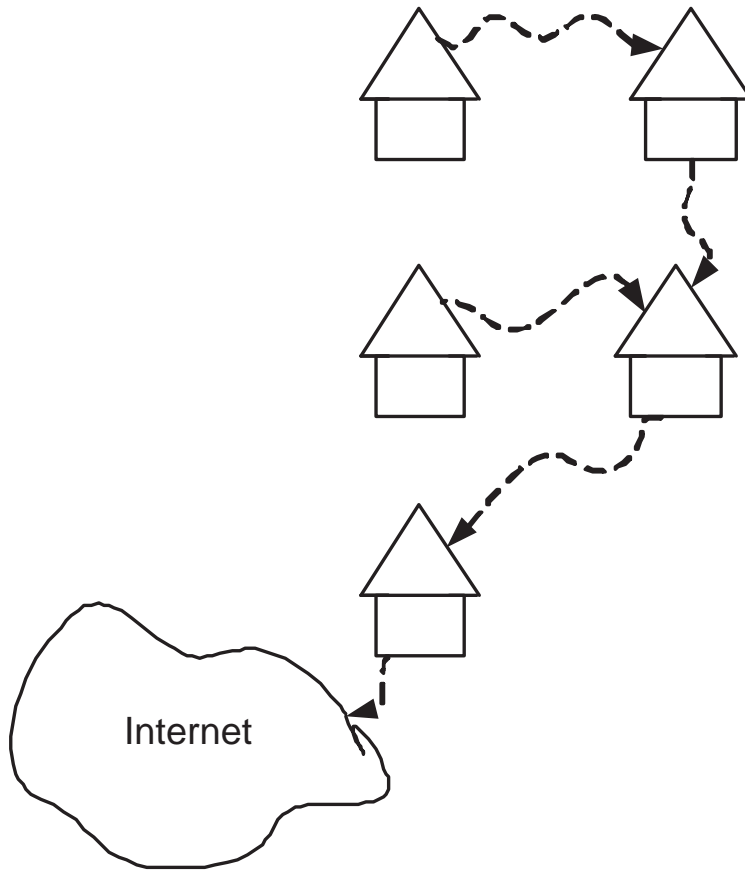

Figure 1.2: **A Wireless Community Network.**

WLAN alternative where cabling does not exist and the network site is small. Figure 1.2 depicts a wireless community network. By directly connecting one house to the Internet and allowing the neighbor houses to communicate to the Internet through this house, the Internet connection cost can be much lower for each house.

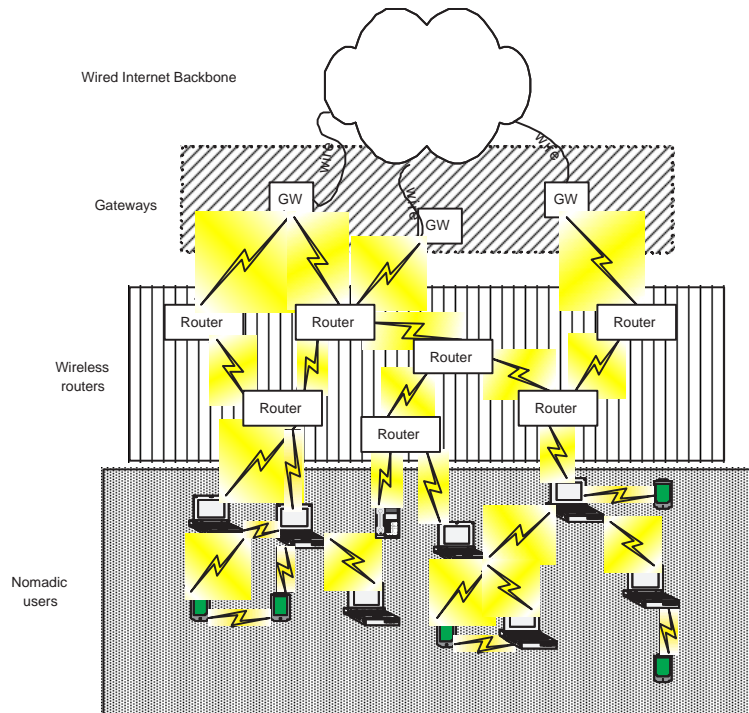

Figure 1.3: **WMN Architecture.**

WMNs have the following three distinct features: First, unlike in pure Ad Hoc networks, where nodes can have high mobility, the positions of nodes in a WMN are fixed. Second, while traffic in a pure Ad Hoc network can be between arbitrary pairs of nodes, in a WMN all traffic is either to or from a designated gateway, which provides access to the Internet. Third, WMN nodes are expected to be powered, and thus energy consumption is not a significant concern.

Unlike flat ad hoc networks, a mesh network has a hierarchical architecture, as shown in Figure 1.3. The upper layer is gateways, which are special wireless routers with a high-bandwidth wired connection to the Internet backbone. The middle layer is wireless routers (also referred to as mesh routers), communicating among each other, providing wireless data services to the lower layer, nomadic users (also referred to as mesh clients), as well as from mesh clients to gateways. The wireless routers and wired gateways form a wireless backhaul communication system, providing each mobile user with a low-cost, high-bandwidth, and seamless multi-hop connectivity. Specifically, the traffic originates from the mobile user, traverses the mesh routers, and is distributed from a gateway to the Internet.

1.1 Motivations

The desirable design criteria of WMNs are as follows:

(1) Self-managing: WMNs should be self-forming, self-configuring and self-healing. New nodes added to the WMNs should automatically discover

possible wireless routers and optimal paths. At the same time, the wireless routers should be able to reorganize according to the new available routes.

(2) Scalable: Scalability refers to the ability of the system to handle a greater traffic volume as the number of nodes in the network increases. The multi-hop architecture of wireless mesh networks should allow for *spatial reuse* of the radio resource, and this, combined with efficient power management and optimized channel assignment, should lead to large networks.

(3) Reliable: In a grid or random WMN architecture, redundant paths should be provided by a wireless backbone among mobile users. This should eliminate single points of failure and potential bottleneck links at non-gateway nodes, thus increasing network reliability.

(4) High Capacity: In order to be an effective alternative to a wired network, the capacity of a WMN should be similar. E.g., if the WMN is providing last-mile access, the capacity available to end users should be comparable to the broadband access provided by cable or DSL networks.



Figure 1.4: **A Single-channel 5-Node Chain.**

(5) Fairness: Network resources should be fairly divided among different users. Fairness is an important requirement in WMNs as it ensures that all flows in the network receive fair service irrespective of their distance from the gateway.

Each of these desirable design criteria present unique problems in WMNs. For example, WMNs have poor capacity because of wireless channel contention among nodes. The channel contention is illustrated in Figure 1.4. With a transmission range of 250m and interference range of 550m, and each node is 200m apart from its neighbors, when node A is transmitting, neither nodes B nor C can transmit at the same time, because they are within the interference range of node A. Also, if D transmits then B will not be able to receive from A. Similarly, when node B is transmitting, none of nodes A, C, or D can transmit, since they are all within the same interference range. This is a simple chain topology. In more complex wireless network channel contention can be much worse. A common approach to dealing with poor

capacity is to use multiple interface cards with each interface operating on a different channel (see [15]).

This thesis focuses on providing fairness in multi-channel WMNs. Current WMNs undergo extreme network-layer unfairness among different flows without any fairness control mechanism.

The 802.11 MAC in DCF mode offers users an equal probability to send a packet in the hope of achieving fairness within a local wireless network. However, Heusse, et al. [7] found that when a host with low bit rate captures the channel, it would penalize others degrading the network throughput to the slow host's level. This unfairness problem is somewhat alleviated under TCP because the slow sender also slows down the Access Point, which has to send ACKs back to the slow sender, and therefore contends with other nodes. This is a very simple and primitive wireless network model, from which we may safely reach the following conclusions:

- (1) Fairness problems exist in even the simplest form of wireless network;

(2) One of the main reasons that cause the problem is the MAC protocol, with hosts of various transmission qualities;

(3) Higher-layers' protocols (such as TCP/UDP) can have a profound influence on the traffic, and therefore, the fairness problem itself.

As a more complex network architecture, WMN's multi-hop feature brings additional unfairness problems among users. Due to WMN's traffic pattern, each node along the path to / from a gateway has to relay other nodes' traffic as well as transmitting its own traffic. This leads to an extra contention between a node's own traffic and its relayed traffic, besides the originally existing contention with other nodes for the same designated gateway. This extra contention can cause the nodes close to a gateway to starve the nodes further away from the gateway when the traffic load at each node increases and the network capacity cannot satisfy the total users' demand. This unfairness problem is illustrated by the scenario in Figure 1.5, with each node sending traffic G to the gateway GW . Figure 1.6 shows how node 1 completely starves node 2, instead of having the same throughput. The reason for this unfairness problem is discussed further in detail in Chapter 2.

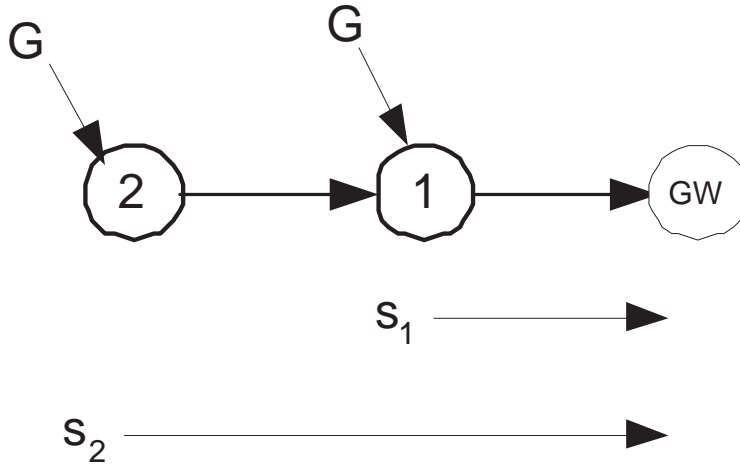

Figure 1.5: **A Single-channel 3-Node Chain With 2 Streams.**

Our first objective is to ensure the maximal allowed transmission rate to be applied to each stream in this situation, in order to ensure fair bandwidth usage among all the users, and at the same time to ensure full utilization of total network resources.

1.1.1 Multi-channel Mesh Networks

In multi-channel WMNs, each node is equipped with two or more wireless cards, and can communicate with different neighbors on different channels simultaneously. Although multiple interface cards assigned to multiple chan-

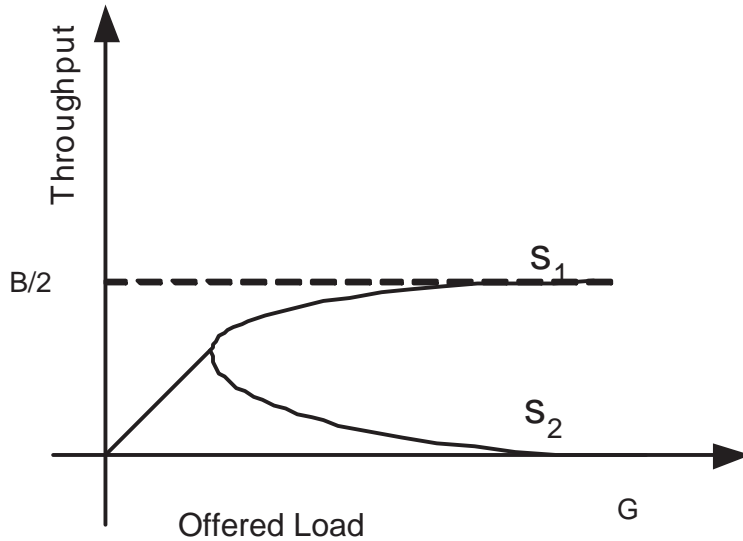

Figure 1.6: **Throughput Plot for Figure 1.5.**

nels can increase the total network capacity and hence the overall network throughput, we have found that different channels reach their maximal capacities at different traffic rates, even though all channels have the same MAC-layer capacity, due to different link usage by different streams. Our second objective is to ensure optimal transmission rate to be applied to each stream in this situation, according to different bandwidth usage at different channels, such that besides ensuring fair-bandwidth usage among all the users, we also need to ensure the network resources at all channels are fully utilized.

1.2 Contribution

Based on our objectives, our main contributions are:

(1) We generalize the fairness constraints defined in existing single-channel fairness reference models to multi-channel models;

(2) By adopting the concepts of link-usage matrix and medium-usage matrix to represent network topology and status, and using Collision-domain theory and Clique-graph theory to represent link-contention area, we develop a computational model to compute the optimal MAC-layer bandwidth allocated to each stream in multi-channel WMNs.

(3) We validate our model by simulation.

(4) We use simulation to show that the single-channel fairness algorithm can, using the above computational model, be extended to the multi-channel environment.

The rest of this thesis is as follows: Chapter 2 discusses the reason that

802.11 cannot ensure fairness in WMNs, two major theories to represent contention area, and previous work done to achieve fairness in WMNs. Chapter 3 defines our single-channel and multi-channel computational models to compute the optimal transmission rates for each stream in WMNs, based on absolute fairness and max-min fairness, with simulation results shown for certain topologies and for a large number of experiments. Chapter 4 presents some simulation results when applying the computational model to rate limit transmission rates at each stream source.

Chapter 2

Background and Related Work

This chapter presents the definitions of fairness, the reason that 802.11 cannot ensure fairness in multi-hop WMNs, two major theories to represent contention area, and previous work done to achieve fairness in WMNs.

2.1 Definitions of Fairness

The fairness definition identifies the optimal allocation of the available resources according to some pre-determined criterion. Three popular types of fairness definitions are as follows.

Let x be a vector of flow rates

$$x = (x_s; s \in S)$$

where x_s is the flowrate of stream s for all active streams S in the network.

We assume all flows have unlimited demand. Kelly et al. [12] define a set of flowrates as feasible if rates are non-negative and the aggregate rate of all flows is not greater than the link capacity.

2.1.1 Absolute Fairness

Under absolute fairness, the rates are equally distributed between all the streams. For example, consider a system in which there are two flows, s_1 and s_2 . The system provides absolute fairness if it always provides the same data rate B to both flows.

2.1.2 Max-min Fairness

Simply allocating rates to each flow equally is not always a good solution, since some flows may be able to get more than others without decreasing

others' shares. This leads to the definition of max-min fairness.

An allocation is said to be max-min fair if no rate in the allocation can be increased without simultaneously decreasing the rate of another allocation that is already smaller. Mathematically, a vector of rates

$$x = (x_s; s \in S)$$

is max-min fair if for each $s \in S$, x_s cannot be increased while maintaining feasibility without decreasing some $x_{s'}$, for some s' for which $x_{s'} \leq x_s$.

For example, consider a system in which there are two flows, s_1 and s_2 . Assume that flow s_1 gets a data rate of B_1 and flow s_2 gets a data rate of B_2 , where $B_1 < B_2$. The system is max-min fair if B_2 cannot be raised without decreasing the flow rate B_1 .

2.1.3 Proportional Fairness

An allocation x is defined as proportionally fair if for any other feasible allocation x' , the aggregate of the proportional change is 0 or negative.

$$\sum_{s \in S} \frac{(x'_s - x_s)}{x_s} \leq 0$$

TCP is an example of proportional fairness, as it provides throughput which is proportional to a flow's round-trip-time (RTT).

2.2 Wireless Transmission Basics

In a wireless environment, whether or not a receiver can correctly decode a radio signal from a transmitter depends on both the receiver's ability to detect the signal, and the distance between the receiver and the transmitter[1]. These factors can be modeled by two parameters, transmission range and interference range.

Transmission Range: The transmission range is the range within which

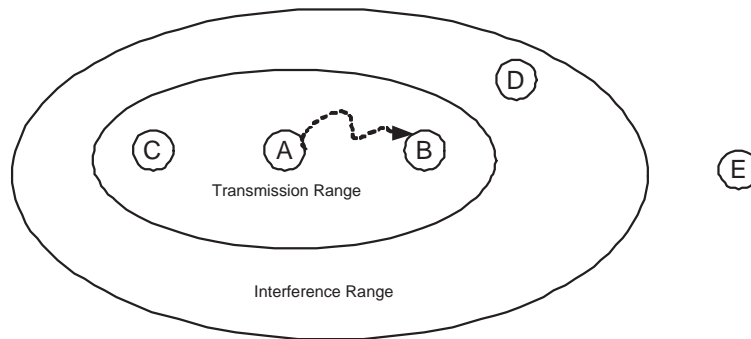

Figure 2.1: **Transmission Range and Interference Range.**

the receiver of a packet can receive and decode the packet correctly.

Interference Range: The interference range is the range within which the transmission cannot be decoded correctly by the receiver but is of sufficient power/energy to disrupt the correct reception of other packets that the receiver could also be receiving.

In Figure 2.1, nodes B and C are within transmission range of A, node D is not within transmission range of A, but is within interference range of A, while node E is outside of interference range of A. When A is sending a packet to B, neither C nor D can send or receive packets from other nodes, in order to avoid collision. Node E, however, can either send or receive.

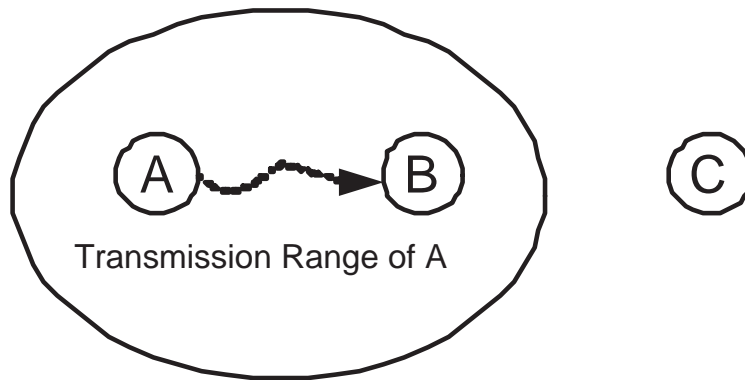

Figure 2.2: **The Hidden Terminal Problem.**

In wireless networks there is a problem referred to as the hidden terminal problem. As illustrated in Figure 2.2, nodes A and C cannot communicate directly, since they are not within the same radio range. From the perspective of C, A is a “hidden” node. This allows A and C to transmit to B simultaneously, thus causing a collision at B. Any wireless MAC must deal with this problem.

2.3 The 802.11 Standard

The 802.11 wireless LAN can operate in one of two configurations: with a base station (access point) or without. In addition, the 802.11 standard supports two modes of operation[19]: point coordination function (PCF), which

uses a base station to control all activity in its cell, and distributed coordination function (DCF), which does not use any kind of central control. All implementations must support DCF but PCF is optional.

In PCF mode, time on the medium is divided into the contention-free period (CFP) and the contention period. During the CFP, the base station polls the other stations, asking them if they have any frames to send. Since transmission order is completely controlled by the base station, in CFP, no collisions ever occur, except those caused by other devices that are not in the transmission range of the AP, but are within interference range of either the AP or the mobile client.

In DCF mode and in the contention period of PCF mode, 802.11 uses Carrier Sense Multiple Access with Collision Avoidance (CSMA/CA), with two methods of operation supported in order to resolve the hidden terminal problem[19]:

- (1) Physical channel sensing: A station senses the channel to make sure it is idle before trying to transmit. It does not sense

the channel while transmitting but emits its entire frame, which may be destroyed at the receiver due to interference there. If the channel is busy, the sender defers to a random time in the future until the channel goes idle and then starts transmitting. If a collision occurs, determined by the absence of acknowledgment (ACK), the colliding stations increase the bound of the random deferring time, called contention window (CW), using the Ethernet binary exponential backoff (BEB) algorithm, and then try again later.

(2) Virtual channel sensing: This method is based on MACAW. The 802.11 MAC allows stations to use two signals, request to send (RTS) and clear to send (CTS), to reserve the channel before the actual data/ACK frame transmissions. In Figure 2.3, when A decides it wants to send data to B. It begins by sending an RTS frame to B to request permission to send it a frame. This RTS frame not only reserves radio link for transmissions, but also silences any stations that hear it. When B receives this request, it may decide to grant permission, in which case it sends a CTS

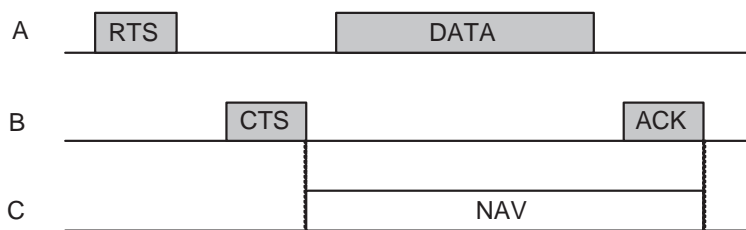

Figure 2.3: **The Use of Virtual Sensing Using CSMA/CA.**

frame back. Upon receipt of the CTS, A now sends its frame and starts an ACK timer. Upon correct receipt of the data frame, B responds with an ACK frame, terminating the exchange. Although C is beyond A's sending range, it is silenced by the CTS from B. From the information provided in the CTS, C can estimate how long the sequence will take, including the final ACK, so it asserts a network allocation vector (NAV) for itself.

2.3.1 The Effect of 802.11 on Fairness in WMNs

IEEE 802.11 standard was designed to provide fairness in a single-hop network. When several nodes are in the same contention area, the standard requires each node to pick a random backoff from (approx.) the same window size. This translates into improved fairness for various nodes in a single-hop

network. Hence, 802.11 can ensure all nodes equal probability to access the channel.

However, notice that the fairness 802.11 provides is only for a single-hop wireless local area network, where all the nodes are within transmission range to the wired backhaul network, and each packet needs to traverse just one hop to the Internet.

In a WMN, due to its traffic pattern, all traffic is either to or from a designated gateway; each node along the path has to relay other nodes' traffic as well as transmitting its own traffic. This causes extra channel contention between a node's own traffic and its relayed traffic, besides the originally existing traffic with other nodes for the same gateway. The further a node is away from the gateway, the more hops its data has to go through to reach the gateway, the higher chance its data will encounter collisions, queueing delay and loss, and the lower throughput this node will have. This causes the phenomenon that the nodes close to a gateway starve the nodes further away from the gateway in WMNs. Some previous work [4][8][10] has well-described this unfairness. Thus our first conclusion is that 802.11 cannot

ensure fairness for multi-hop WMNs.

Next, we discuss if 802.11 can really ensure fairness even in a single-hop LAN. As described in Section 1.1, the 802.11 MAC protocol offers users equal probability to transmit a packet when in DCF mode, in the hope to achieve fairness within a local wireless network. However, it has been found that when a host with low bit rate captures the channel [7], it would penalize others with a longer waiting time, and degrade the network throughput to the slow host's level. Similarly, nodes with large packets to send acquire more time than those with smaller packets. Some work [4] has been done to bring up time fairness in WMN, i.e., instead of allowing each node equal chance to access channel, the same amount of time should be assigned to each node for the channel usage. Our second conclusion is that time fairness is a more reasonable way to assign each node network resource. That said, we notice that in a WMN where each link has equal link capacity, the same amount of time leads to the same amount of throughput.



Figure 2.4: A Chain Topology.

2.4 Fairness Constraints in Single-channel WMN

Based on the discussion in Section 2.3.1, time fairness should be applied to a single-channel WMN, i.e., the same amount of time should be assigned to each node for its first hop sending its own traffic to the designated gateway. In other words, the same amount of time should be assigned to the first hop of each stream. In the special case where each link in a network has equal link capacity, this means the same amount of throughput or transmission rate should be allowed for each stream.

Collision-domain theory [10] and clique-graph theory [6] are two common approaches to represent the link-contention area in a wireless LAN. We use the scenario in Figure 2.4 to describe these two theories. Each node is 200m from its neighbors. The transmission range is 250m, and the interference is 550m, per the default ns2 parameters. We define two links as interfering with each other if they cannot be used to transmit at the same time.

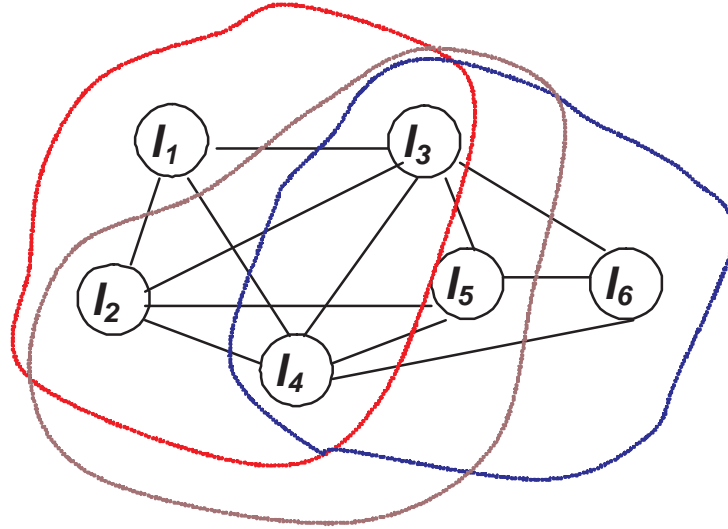

Figure 2.5: **Contention Graph G for Scenario in Figure 2.1.**

2.4.1 Clique-graph Theory

In clique-graph theory, a link-contention graph G is used to represent the contention area for *all* the links. G will represent all the links as a set of vertices V , and will have an edge connecting any two links within interference range. For the scenario in Figure 2.4, the link-contention graph, G , will be as shown in Figure 2.5, link l_1 is within interference range of l_2 , l_3 , and l_4 . Link l_2 is within interference range of l_3 , l_4 , l_5 and l_1 . Link l_3 is within interference range of l_4 , l_5 , l_6 , l_1 and l_2 ; and so on.

A *clique* in a link-contention graph is a set of vertices that represent a

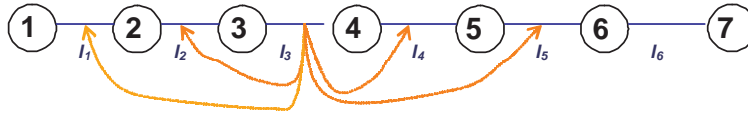

Figure 2.6: **Collision Domain for Scenario in Figure 2.4.**

set of links that mutually conflict. For example, l_1 and l_2 form a clique. The circled areas in the link-contention graph G represent the *maximal cliques*. In this case, the maximal clique will always have the degree of 4. This implies at any time, there could be 4 links contend each other. Based on the clique-graph theory, if the total available bandwidth within a contention area is B , the fair share for each link is $B/4$. Note that the bandwidth within each contention area must be equal in this model.

2.4.2 Collision-domain Theory

In collision-domain theory, a collision domain is used to represent the contention area for a *certain* link. Two links contend if one endpoint of one link is within transmission range of one endpoint of the other link. Hence, in Figure 2.4, link l_3 's collision domain contains l_1, l_2, l_4, l_5 and itself, as shown in Figure 2.6.

The fair share is calculated based on the bottleneck collision domain, which is defined as the collision domain that has to forward the most traffic in the network. If node 1 is the gateway, and we assume the simplest case such that traffic starts from node 7 to the gateway, every node along the path has to relay node 7's traffic, each link has the same amount of traffic. It can be shown [10] that the collision domain of link l_3 is the bottleneck collision domain for a chain of length not less than 3. Because the bottleneck collision domain contains 5 links, the fair share is $B/5$.

Note that by the definition of link contention, the collision-domain model under-estimates the impact of contention, as actual contention across the links is based on the interference range which is typically larger than the transmission range. However, as shown in Figure 2.6, l_1 and l_5 can actually transmit simultaneously without causing any collision, but they are considered within the same collision domain when calculating fair share. This over-estimation of contention alleviates the previous under-estimation, thus making collision-domain theory a reasonable way of representing link contention.

2.5 Related Work

The work that is most closely related to this thesis is that of Gambiroza et al. [4] and Jakubczak et al. [8].

2.5.1 Fairness Concepts

A single-channel time fairness reference model is defined by Gambiroza et al. [4]. Their model characterizes the idealized fairness and throughput objectives for multihop wireless backhaul networks. Based on the model, they developed a distributed layer-2 fairness algorithm which targets achieving the fairness of the reference model without modification to TCP. They try to achieve time fairness for different flows. However, their fair share and throughput computation is based on a single-channel network. Also, they consider allocating fair share for aggregate flows, i.e., those flows have one flow origin, but have more than one flow end points, which are rarely the case in a WMN. In this thesis, we generalize their single-channel fairness reference model to the multi-channel case.

Nandagopal et al. [16] discuss the unique characteristics of wireless chan-

nels to argue that the fairness techniques for wireline networks cannot be directly applied. They augment the fairness model of Kelly et al. by addressing the link-layer contentions for the wireless channels.

The statement of time fairness is based on the analysis of the problem that a host with low bit rate captures the channel. It would penalize others into waiting a longer time, and degrade the network throughput to the slow host's level. To address this problem, Tan et al. [18] state that: "Channel allocation should be based on channel time, instead of transmission opportunities; Limit the amount of channel time per transmission opportunity; and dynamically allocate the probability of transmission opportunities as a function of the observed channel time share, such that the long-term global allocation of channel time is not affected by the transmission strategies used by nodes." However, the MAC protocol at each node must periodically determine its contention window size as a function of its channel time share. More work needs to be done in order to implement this scheme.

In a multi-channel WMN, some effort has been drawn to maximize the network throughput and to enhance fairness. Tang et al. [20] formulate

a Linear Programming (LP) approach for the max-min fairness guaranteed Maximum throughput Bandwidth Allocation (MMBA) problem, which seeks a feasible max-min guaranteed bandwidth allocation vector for all nodes in the network. They also propose an algorithm to optimally solve the Lexicographical Max-Min Bandwidth Allocation (LMMBA) problem, which seeks a feasible lexicographical max-min bandwidth allocation vector for all nodes in the network. Although, as they stated in their paper, “... this is the first paper addressing maximum throughput and fair bandwidth allocation in the context of multi-channel WMNs and proposing LP formulations and a polynomial time algorithm to provide optimal solutions....,” their bandwidth allocation is based on each node, taking multiple interface cards into account, which makes it necessary to use a derived auxiliary graph to represent both the nodes and the associated communication channels. When calculating the bandwidth for each node, a residual graph has to be constructed to decrease the running time. Compared with their work, our throughput computational model is based on each stream, which makes it possible to use several matrices to represent both the stream activity status and the link-contention situation, and to complete the computation in polynomial time.

2.5.2 Fairness Implementations

Jakubczak et al. [8] present a three-step explicit rate-control algorithm to address the fairness problem at the level of the network layer. Specifically, their algorithm contains three parts: a distributed algorithm for the delivery of stream-activity information, by piggybacking the information on data frames, a computational task performed at each node for determining the fair-share rate for each stream, and a self-policing algorithm for limiting the fair-share rate to the computed rate. This rate-control algorithm has the advantage that no modifications are required to the underlying 802.11 MAC. However, this work is limited to a single-channel WMN. In this thesis, we adopt the idea of the link-usage matrix and medium-usage matrix used in their computational task to compute the fair share for each stream in a multi-channel WMN.

Jamshaid et al. [9] exploit the traffic trends present in WMNs to present a unique mechanism for enforcing fairness. Since traffic in WMNs is mostly directed to and from the gateways, the authors enforce rate limiting at the gateway. The gateway allows only the fair share data to pass through. By delaying or dropping excess packets at the gateway, the algorithm slows down

the greedy TCP flows, thus allowing the starving nodes to transmit. This scheme works only with adaptive traffic like TCP. While it also limits greedy UDP senders, it does not necessarily slow them down, and hence does not improve fairness in that case. Also, the implementation is based on single-channel WMNs.

To address the unfairness problem among different flows when TCP spans multihop wired and wireless ad hoc networks, Yang et al. [21] propose to use a simple non-work-conserving scheduling algorithm to work with the 802.11 MAC protocol. The main purpose of this scheduling algorithm is to penalize those aggressive nodes, to some extent, which occupy the channel persistently, and help nodes which fail medium contention consecutively to retain the resource. The challenge of this scheduling algorithm is the trade-off between fairness and throughput. Specifically, it is difficult and tricky to generate a reasonable value setting of the timer which controls the output rates of different queues.

To address the spatial bias problem, i.e., the nodes close to the gateway will eventually starve the nodes further away from the gateway [11], Jun and

Sichitiu propose to enqueue packets for different flows originating from different nodes separately. The limitation of this scheme is the possible lacking of resources to do per-flow queuing in some networks. It also requires weighted queuing to ensure fairness, and no mechanism is provided to determine the weights.

In Chapter 3, we discuss the existing single-channel fairness reference model for solving fair time share in a certain contention area [4]. Then we adopt the link-usage matrix and medium-usage matrix [8], combined with the time-fairness reference model to calculate the fair throughput share in single-channel WMNs. In order to make our description continuous, we present the discussion of the single-channel reference model and the adoption of the two major matrices in Chapter 3.

Chapter 3

Multi-channel WMN Capacity

Models

In this chapter we derive a multi-channel fairness reference model from the existing single-channel fairness reference model [4] for solving fair time share in a certain contention area. Then we adopt the link-usage matrix and medium-usage matrix [8] to solve the fair time share and fair throughput share in multi-channel WMNs. Next we derive a computational method based on that for absolute fairness to achieve max-min fairness in multi-channel WMNs.

We study the quality of those models by simulation on various network

configurations. We have found that in the multi-channel environment, our extension to the collision-domain model generally provides an accurate estimation of network capacity.

3.1 Time Fairness in Single-channel Contention Area

The original reference model for fairness in single-channel multihop wireless backhaul networks has the following four objectives[4]:

(1) Temporal Fairness. Time rather than throughput should be considered as the basic network resource that needs to be fairly shared.

(2) Spatial Reuse. In their model, each transit-access-point(TAP) corresponds to a single residence, small business, or hot spot. Network resources can be reclaimed by TAP-aggregated flows when they are unused either due to lack of demand or in cases of sufficient demand in which flows are bottlenecked elsewhere.

(3) Spatial Bias Removal. Spatial bias must be eliminated to ensure that nodes close to a gateway do not receive a disproportionately greater share of resources than nodes further away from the gateway.

(4) Ingress Aggregate: the targeted granularity of fairness is a TAP-aggregated flow, and each TAP's traffic should be treated as a single aggregate, independent of the number of mobile users supported by the TAP.

We adopt the first three objectives: Temporal Fairness, Spatial Reuse, and Spatial Bias Removal to compute fair time share in certain single-channel contention area. Due to the traffic pattern of WMNs, the definition of stream in our model is different from the definition of flow in the original TAP fairness reference model. That is, WMN traffic patterns exclude the case where a stream starts from a certain node but ends at different other nodes, since every node other than the gateway will send traffic destined to the gateway. This makes the fourth objective unnecessary for our model.

The network for discussion consists of N nodes and F streams.

r_f : the predetermined route each stream f traverses

h_f : the number of hops stream f traverses

ρ_i^f : throughput of stream f crossing link i

t_i^f : the time needed for stream f traffic to be transmitted on link i

C_i : fixed capacity link i has

The Flow Preservation Property (FPP) states that the time share assigned to each link along the flow must be equal to the time required for forwarding all incoming packets. If it is shorter, there are packets that have been transmitted by previous links but cannot get to the destination; if it is longer, the link will be idle during part of the allocated time share. Hence, by knowing that

$$\rho_m^f = \rho_n^f$$

$$\rho_m^f = t_m^f C_m$$

$$\rho_n^f = t_n^f C_n$$

the equation representing the FPP is:

$$\forall m, n \in r_f, \quad t_m^f C_m = t_n^f C_n$$

In a WMN, we define a stream as unidirectional traffic between a regular TAP to or from the gateway, define $TA(i)$ as the stream with ingress TAP_i and with egress gateway, and define T_i as the candidate TAP fair share for stream $TA(i)$. T_i is the fraction of time to be assigned to the first hop of stream $TA(i)$. Due to the Flow Preservation Property (FPP), this number determines the fraction of time the stream is assigned at any other hop.

$$T_i C_i = t_n^{(i)} C_n$$

Where C_i is the capacity of the link from ingress TAP_i to the next hop, $t_n^{(i)}$ is the time needed for stream $TA(i)$ traffic to be transmitted on link n , and C_n is the capacity of link n .

The spatial reuse constraint can be stated as: for all streams f in the same

contention area,

$$\sum_{f=1}^F \sum_{l \in r_f} t_l^f \leq 1 \quad (3.1)$$

Spatial Bias Removal constraint can be ensured by the equation:

$$\forall f, \quad T_a(f) = t_{l_1}^f \quad (3.2)$$

Moreover, t_l^f in equation(3.1) must satisfy the Flow Preservation Properties, as stated in equation:

$$\forall i, j \in r_f, \quad t_i^f C_i = t_j^f C_j \quad (3.3)$$

under spatial bias constraint, the fair time share of all flows that are in the same contention area should be equal, as stated in equation:

$$T_a(f) = T_a(g) \quad (3.4)$$

Equation (3.2) and (3.4) lead to equation: for all streams f and g that are in the same contention area,

$$t_{l_1}^f = t_{l_1}^g \quad (3.5)$$

Equations (3.1), (3.3) and (3.5) lead to the time share of any stream for its first hop. Thus, for all streams f that are in the same contention area,

$$t_{l_1}^i = \left(\sum_{f=1}^F \frac{C_{l_1}^f}{\bar{\rho}^f} \right)^{-1}, \quad 1 \leq i \leq F \quad (3.6)$$

Note: “Contention area” refers to either contention neighborhood (maximal clique), or collision domain. Which meaning is taken depends on which model is adopted to represent collision region of certain link.

Equation:

$$\bar{\rho}^f = \left(\sum_{l \in r_f} \frac{1}{C_l} \right)^{-1} \quad (3.7)$$

and equation (3.6) leads to the throughput of stream f , as in equation:

$$\rho^f = t_{l_1}^f C_{l_1}^f \quad (3.8)$$

and the time share for any link l , as in equation:

$$t_l^f = \frac{\rho^f}{C_l} \quad (3.9)$$

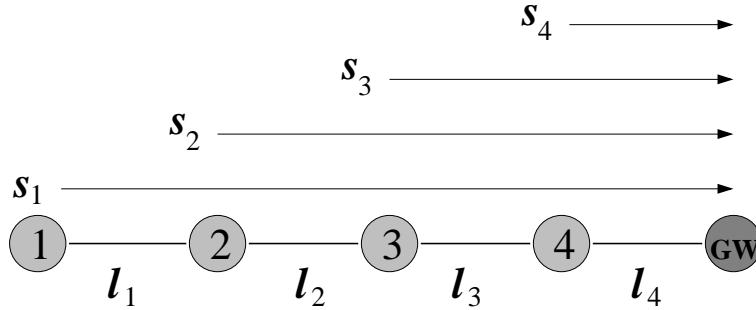

Figure 3.1: A Simple WMN with Four Streams.

3.2 Time Fairness in Single-channel WMN

Although simulation results regarding single-channel WMNs are given in [4], the computation of fair share of each stream we can find in their paper is only based on a certain link's contention area. In order to compute the fair time share and throughput (or maximal allowed transmission rate) of each stream regarding to the overall WMN, we adopt the concepts of link-usage matrix and medium-usage matrix, defined in [8].

We use the scenario depicted in Figure 3.1, to illustrate the computational process. The link-usage matrix is defined to be \mathbf{L} , where:

$$L[i, j] = \begin{cases} 1 & \text{when stream } s_i \text{ uses link } l_j \\ 0 & \text{otherwise} \end{cases}$$

which for the sample WMN in Figure 3.1 is:

$$\mathbf{L} = \begin{bmatrix} 1 & 0 & 0 & 0 \\ 1 & 1 & 0 & 0 \\ 1 & 1 & 1 & 0 \\ 1 & 1 & 1 & 1 \end{bmatrix}$$

Based on \mathbf{L} , we define \mathbf{L}' , with link-capacity values included, as:

$$L'[i, j] = \frac{1}{C_j} L[i, j]$$

which for the sample WMN in Figure 3.1 is:

$$\mathbf{L}' = \begin{bmatrix} \frac{1}{C_{l_1}} & 0 & 0 & 0 \\ \frac{1}{C_{l_2}} & \frac{1}{C_{l_2}} & 0 & 0 \\ \frac{1}{C_{l_3}} & \frac{1}{C_{l_3}} & \frac{1}{C_{l_3}} & 0 \\ \frac{1}{C_{l_4}} & \frac{1}{C_{l_4}} & \frac{1}{C_{l_4}} & \frac{1}{C_{l_4}} \end{bmatrix}$$

The medium-usage matrix is defined to be \mathbf{M} , where:

$$M[i, j] = \begin{cases} 1 & \text{when } l_j \in u_i \\ 0 & \text{otherwise} \end{cases}$$

where u_i denotes the collision domain for certain link l_i . For the sample WMN in Figure 3.1, \mathbf{M} is:

$$\mathbf{M} = \begin{bmatrix} 1 & 1 & 1 & 0 \\ 1 & 1 & 1 & 1 \\ 1 & 1 & 1 & 1 \\ 0 & 1 & 1 & 1 \end{bmatrix}$$

The stream throughput vector \mathbf{R} is defined in [8]: $R[i]$ is the throughput for a certain stream i .

Recall Equation (3.1): for all streams f in the same contention area,

$$\sum_{f=1}^F \sum_{l \in r_f} t_l^f \leq 1$$

By using link-usage matrix and medium-usage matrix, Equation (3.1) can be

rewritten as follows:

$$\mathbf{M}\mathbf{L}'\mathbf{R} \leq 1 \quad (3.10)$$

where \mathbf{M} is medium-usage matrix, \mathbf{L}' is link-usage matrix with link-capacity values, \mathbf{R} is stream throughput vector.

For the sample WMN on Figure 3.1, Equation (3.10), or four sets of fairness constraints, with each row of \mathbf{M} representing one constraint, should be applied as follows:

$$\begin{bmatrix} 1 & 1 & 1 & 0 \\ 1 & 1 & 1 & 1 \\ 1 & 1 & 1 & 1 \\ 0 & 1 & 1 & 1 \end{bmatrix} \begin{bmatrix} \frac{1}{C_{l_1}} & 0 & 0 & 0 \\ \frac{1}{C_{l_2}} & \frac{1}{C_{l_2}} & 0 & 0 \\ \frac{1}{C_{l_3}} & \frac{1}{C_{l_3}} & \frac{1}{C_{l_3}} & 0 \\ \frac{1}{C_{l_4}} & \frac{1}{C_{l_4}} & \frac{1}{C_{l_4}} & \frac{1}{C_{l_4}} \end{bmatrix} \begin{bmatrix} R(s_1) \\ R(s_2) \\ R(s_3) \\ R(s_4) \end{bmatrix} \leq \begin{bmatrix} 1 \\ 1 \\ 1 \\ 1 \end{bmatrix}$$

Recall Equation (3.5): for all streams f and g that are in the same contention area,

$$t_{l_1}^f = t_{l_1}^g$$

For the first constraint:

$$R(s_1) = t_{l_1}^{s_1} C_{l_1} = t^{(1)} C_{l_1}$$

$$R(s_2) = t_{l_2}^{s_2} C_{l_2} = t^{(1)} C_{l_2}$$

$$R(s_3) = t_{l_3}^{s_3} C_{l_3} = t^{(1)} C_{l_3}$$

$$R(s_4) = t_{l_4}^{s_4} C_{l_4} = t^{(1)} C_{l_4}$$

where $t^{(1)}$ denotes the fair time share for each stream based on link 1's contention area, solving the first constraint is same as:

$$t^{(1)} [C_{l_1} (\frac{1}{C_{l_1}} + \frac{1}{C_{l_2}} + \frac{1}{C_{l_3}} + 0) + C_{l_2} (0 + \frac{1}{C_{l_2}} + \frac{1}{C_{l_3}} + 0) + C_{l_3} (0 + 0 + \frac{1}{C_{l_3}} + 0) + 0] = 1$$

Hence,

$$t^{(1)} = [C_{l_1} (\frac{1}{C_{l_1}} + \frac{1}{C_{l_2}} + \frac{1}{C_{l_3}}) + C_{l_2} (\frac{1}{C_{l_2}} + \frac{1}{C_{l_3}}) + C_{l_3} (\frac{1}{C_{l_3}})]^{(-1)}$$

If we compare the above equation with Equation (3.6), for all streams f that

are in the same contention area,

$$t_{l_1}^i = \left(\sum_{f=1}^F \frac{C_{l_1}^f}{\bar{\rho}^f} \right)^{-1}, \quad 1 \leq i \leq F$$

and Equation (3.7):

$$\bar{\rho}^f = \left(\sum_{l \in r_f} \frac{1}{C_l} \right)^{-1}$$

we can prove that the above three equations are equivalent.

As we got $t^{(1)}$ from the first constraint, we can also get $t^{(2)}, t^{(3)}, t^{(4)}$ from the last three constraints, which are the fair time shares computed based on link 2, link 3, link 4's contention area. The fair time share for each stream based on the bottleneck link's contention area is:

$$t = \min(t^{(1)}, t^{(2)}, t^{(3)}, t^{(4)})$$

The fair time share computed from the bottleneck link's contention area should be used to calculate the maximal allowed transmission rate used by

each stream:

$$R(s_1) = tC_{l_1}$$

$$R(s_2) = tC_{l_2}$$

$$R(s_3) = tC_{l_3}$$

$$R(s_4) = tC_{l_4}$$

3.3 Absolute Fairness in Single-channel WMN

Absolute fairness is a special case of time fairness that occurs frequently in single-channel meshes, where channel capacity is identical across links. We therefore assume each link has equal link capacity in the WMN:

$$C_{l_1} = C_{l_2} = C_{l_3} = C_{l_4} = C_l$$

and so

$$R(s_1) = R(s_2) = R(s_3) = R(s_4) = R$$

The following four sets of fairness constraints should be applied to the sample

WMN:

$$\begin{bmatrix} 1 & 1 & 1 & 0 \\ 1 & 1 & 1 & 1 \\ 1 & 1 & 1 & 1 \\ 0 & 1 & 1 & 1 \end{bmatrix} \begin{bmatrix} 1 & 0 & 0 & 0 \\ 1 & 1 & 0 & 0 \\ 1 & 1 & 1 & 0 \\ 1 & 1 & 1 & 1 \end{bmatrix} \begin{bmatrix} R^{(1)} \\ R^{(1)} \\ R^{(1)} \\ R^{(1)} \end{bmatrix} \leq \begin{bmatrix} C_l \\ C_l \\ C_l \\ C_l \end{bmatrix}$$

We can get $R^{(1)}$, $R^{(2)}$, $R^{(3)}$, $R^{(4)}$ from the above four constraints, which are the fair throughput shares computed based on link 1, 2, 3 and 4's contention area. The fair throughput share for each stream based on the bottleneck link's contention area is:

$$R = \min (R^{(1)}, R^{(2)}, R^{(3)}, R^{(4)})$$

3.4 Time Fairness in Multi-channel Contention

Area

In multi-channel networks, there are I channels available, each node is equipped with two or more wireless interfaces, with each interface assigned to a certain channel, so each node can transmit and receive at different channels simul-

taneously. We presume different channels do not interfere with each other even though they are accessed at the same time. Therefore, Equation (3.1) should be modified for the multi-channel case: for all streams f that are in the same contention area, m is the channel used by the first link of stream f ,

$$\sum_{f=1}^F \sum_{l \in r_{f,m}} t_l^{f,m} \leq 1, \quad 1 \leq m \leq I \quad (3.11)$$

From Equation (3.11), (3.3) and (3.5): for all streams f that are in the same contention area,

$$t_{l_1}^{i,m} = \left(\sum_{f=1}^F \frac{C_{l_1}^{f,m}}{\bar{\rho}^{f,m}} \right)^{-1}, \quad 1 \leq i \leq F, 1 \leq m \leq I \quad (3.12)$$

$$\bar{\rho}^{f,m} = \left(\sum_{l \in r_{f,m}} \frac{1}{C_l} \right)^{-1} \quad (3.13)$$

Since it is possible that different streams start on different channels (i.e., the first links of those streams are on different channels), Equation (3.11) should be applied to each channel respectively. Different results can be generated from Equation (3.13), and if this is the case, the minimum result should be

taken for further computation; i.e.,

$$t_{l_i}^i = \min_{l_1^m} t_{l_1^m}^{i,m}, \quad 1 \leq i \leq F, 1 \leq m \leq I \quad (3.14)$$

Equations (3.8) and (3.9) can then still be used to compute the throughput of stream f and the time share for any link under the multi-channel case.

3.5 Time Fairness in Multi-channel WMN

Similar to the single-channel WMN case, in order to compute the fair time share and throughput of each stream for the overall multi-channel WMN, the link-usage matrix and medium-usage matrix are adopted.

We take the scenario depicted in Figure 3.2 to illustrate the computation process for multi-channel WMNs. The difference between Figure 3.2 and Figure 3.1 is that in Figure 3.2, link 1 and link 3 are using channel 1, and link 2 and link 4 are using channel 2, while in Figure 3.1 all links are using the same channel.

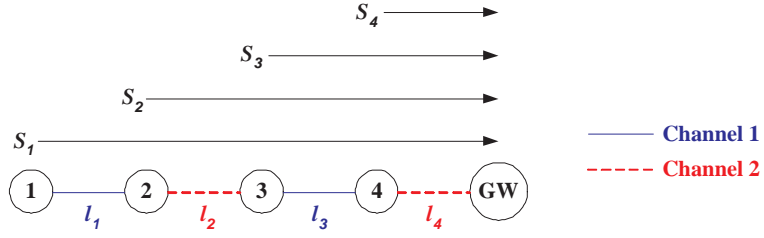

Figure 3.2: A Multi-channel WMN with Four Streams.

$L'[j, i]$ is the same as in the single-channel case:

$$\begin{bmatrix} \frac{1}{C_{l_1}} & 0 & 0 & 0 \\ \frac{1}{C_{l_2}} & \frac{1}{C_{l_2}} & 0 & 0 \\ \frac{1}{C_{l_3}} & \frac{1}{C_{l_3}} & \frac{1}{C_{l_3}} & 0 \\ \frac{1}{C_{l_4}} & \frac{1}{C_{l_4}} & \frac{1}{C_{l_4}} & \frac{1}{C_{l_4}} \end{bmatrix}$$

while $M[i, j]$ will have two different values for channel 1 and channel 2:

$$M^{ch1} = \begin{bmatrix} 1 & 0 & 1 & 0 \\ 0 & 0 & 0 & 0 \\ 1 & 0 & 1 & 0 \\ 0 & 0 & 0 & 0 \end{bmatrix}$$

$$M^{ch2} = \begin{bmatrix} 0 & 0 & 0 & 0 \\ 0 & 1 & 0 & 1 \\ 0 & 0 & 0 & 0 \\ 0 & 1 & 0 & 1 \end{bmatrix}$$

Equation (3.11) can be written as:

$$\mathbf{M}^m \mathbf{L}' \mathbf{R} \leq 1 \quad (3.15)$$

and should be applied to both channels. That is, two sets of constraints should be applied to both channels. For channel 1:

$$\begin{bmatrix} 1 & 0 & 1 & 0 \\ 0 & 0 & 0 & 0 \\ 1 & 0 & 1 & 0 \\ 0 & 0 & 0 & 0 \end{bmatrix} \begin{bmatrix} \frac{1}{C_{l_1}} & 0 & 0 & 0 \\ \frac{1}{C_{l_2}} & \frac{1}{C_{l_2}} & 0 & 0 \\ \frac{1}{C_{l_3}} & \frac{1}{C_{l_3}} & \frac{1}{C_{l_3}} & 0 \\ \frac{1}{C_{l_4}} & \frac{1}{C_{l_4}} & \frac{1}{C_{l_4}} & \frac{1}{C_{l_4}} \end{bmatrix} \begin{bmatrix} t^{(1)} C_{l_1} \\ t^{(1)} C_{l_2} \\ t^{(1)} C_{l_3} \\ t^{(1)} C_{l_4} \end{bmatrix} \leq \begin{bmatrix} 1 \\ 1 \\ 1 \\ 1 \end{bmatrix}$$

On channel 1, the fair time share for each stream based on the bottleneck link's contention area is:

$$t^{ch1} = \min(t^{(1)}, t^{(2)}, t^{(3)}, t^{(4)})$$

Similarly, for channel 2:

$$\begin{bmatrix} 0 & 0 & 0 & 0 \\ 0 & 1 & 0 & 1 \\ 0 & 0 & 0 & 0 \\ 0 & 1 & 0 & 1 \end{bmatrix} \begin{bmatrix} \frac{1}{C_{l_1}} & 0 & 0 & 0 \\ \frac{1}{C_{l_2}} & \frac{1}{C_{l_2}} & 0 & 0 \\ \frac{1}{C_{l_3}} & \frac{1}{C_{l_3}} & \frac{1}{C_{l_3}} & 0 \\ \frac{1}{C_{l_4}} & \frac{1}{C_{l_4}} & \frac{1}{C_{l_4}} & \frac{1}{C_{l_4}} \end{bmatrix} \begin{bmatrix} t^{(1)}C_{l_1} \\ t^{(1)}C_{l_2} \\ t^{(1)}C_{l_3} \\ t^{(1)}C_{l_4} \end{bmatrix} \leq \begin{bmatrix} 1 \\ 1 \\ 1 \\ 1 \end{bmatrix}$$

On channel 2, the fair time share for each stream based on the bottleneck link's contention area is:

$$t^{ch2} = \min(t^{(1)}, t^{(2)}, t^{(3)}, t^{(4)})$$

The lower value between t^{ch1} and t^{ch2} should be taken as the fair time share for each stream in the WMN, and used for further computation:

$$t = \min(t^{ch1}, t^{ch2})$$

The maximal allowed transmission rate used by each stream:

$$R(s_1) = tC_{l_1}$$

$$R(s_2) = tC_{l_2}$$

$$R(s_3) = tC_{l_3}$$

$$R(s_4) = tC_{l_4}$$

3.6 Max-min Fairness

Channel usage not only depends on the channel assignment among the network, it also depends on the link usage of the active streams. Since we cannot assume that streams are uniformly distributed among the network, it is likely that some channel becomes saturated earlier than other channels, i.e., it is rarely the case that:

$$R = R^{ch0} = R^{ch1} = R^{ch2}$$

with

$$R = \min(R^{ch0}, R^{ch1}, R^{ch2})$$

In other words, when some channel reaches its saturation point, there is still some extra bandwidth to use in the other two channels. It would be a waste if we limited the input rate of all the active streams to this “optimal” transmission rate computed based on the most-demanded channel.

When placing the gateway node in the middle of the network, it is often the case that the most-demanded channel will be one of the channels assigned to the gateway's interfaces. Because of the WMN traffic pattern, all the traffic is either starting from or designated to the gateway. This makes the last hop to the gateway the bottleneck link on one of its channels.

To make full use of network resources, instead of calculating one optimal rate based on the most-demanded channel, and rate limiting all the streams to this optimal rate, we calculate two optimal rates, and call them the lower fair share and higher fair share, respectively.

The computation of the lower fair share, which is obtained from the most-demanded channel, is the same as the computation of fair throughput share in the last section. Next, we use this lower fair share to limit the input rate of those streams which take the most-demanded channel to reach, enter or leave the gateway node, and compute the second optimal rate, the higher fair share, the rest of the streams can achieve.

Generally, assuming there are totally I channels available in the WMN,

$$R_{rl} = \min (R^{ch1}, R^{ch2}, \dots, R^{chI}) \quad (3.16)$$

$$R_{low} = R_{rl} \quad (3.17)$$

$$ch_{rl} = ch_i, \quad for \quad 1 \leq i \leq I \quad and \quad R^{chi} = R_{rl} \quad (3.18)$$

R_{low} is the lower fair share, ch_{rl} is the most demanded channel.

If we assume each link has equal link capacity among the whole WMN, we have:

$$\mathbf{M}^m \mathbf{L} \mathbf{R} \leq C_l \quad (3.19)$$

In order to compute higher fair share, Equation(3.19) should be applied to all the channels in the network, along with the following two different sets of

R:

$$R(s_k) = R_{rl}, \quad when \quad s_k \quad taking \quad ch_{rl} \quad to \quad reach \quad the \quad gateway \quad node$$

$$R(s_k) = R, \quad when \quad s_k \quad not \quad taking \quad ch_{rl} \quad to \quad reach \quad the \quad gateway \quad node$$

We take the scenario depicted in Figure 3.3 to illustrate the higher-fair-

share computation process.

$$\mathbf{L} = \begin{bmatrix} 1 & 1 & 0 \\ 0 & 0 & 1 \\ 1 & 1 & 0 \\ 0 & 1 & 0 \\ 1 & 1 & 0 \\ 1 & 1 & 0 \\ 1 & 1 & 0 \\ 0 & 0 & 1 \\ 0 & 0 & 1 \\ 0 & 0 & 1 \\ 0 & 0 & 1 \end{bmatrix}$$

Based on Clique Graph Theory, $M[i, j]$ will have three different sets of values

of maximal cliques for channel 0, channel 1, and channel 2:

$$M^{ch0} = \begin{bmatrix} 0 & 0 & 0 & 1 & 0 & 1 & 0 & 0 & 0 & 0 & 0 \\ 0 & 1 & 0 & 0 & 0 & 1 & 0 & 0 & 0 & 0 & 0 \\ 0 & 1 & 0 & 0 & 0 & 0 & 0 & 0 & 0 & 1 & 0 \end{bmatrix}$$

$$M^{ch1} = \begin{bmatrix} 0 & 0 & 1 & 0 & 0 & 0 & 1 & 0 & 0 & 0 & 0 \\ 0 & 0 & 0 & 0 & 0 & 0 & 1 & 1 & 0 & 0 & 0 \\ 0 & 0 & 0 & 0 & 0 & 0 & 0 & 1 & 0 & 0 & 1 \end{bmatrix}$$

$$M^{ch2} = \begin{bmatrix} 1 & 0 & 0 & 0 & 1 & 0 & 0 & 0 & 0 & 0 & 0 \\ 1 & 0 & 0 & 0 & 0 & 0 & 0 & 0 & 1 & 0 & 0 \end{bmatrix}$$

After the first-step computation, the lowest throughput share is obtained from channel 2:

$$R_{rl} = \min(R^{ch0}, R^{ch1}, R^{ch2}) = R^{ch2}$$

$$R_{low} = R_{rl}$$

$$ch_{rl} = ch2$$

In order to compute higher fair share, Equation (3.19) should be applied to all the three channels in the network, along with the following two differ-

ent values for \mathbf{R} :

$$R(s_0)=R(s_1)=R_{rl}$$

since s_0 and s_1 taking ch_{rl} to reach the gateway node, and

$$R(s_2)=R,$$

since s_2 is not taking ch_{rl} to reach the gateway node

For channel 0:

$$\begin{bmatrix} 0 & 0 & 0 & 1 & 0 & 1 & 0 & 0 & 0 & 0 & 0 \\ 0 & 1 & 0 & 0 & 0 & 1 & 0 & 0 & 0 & 0 & 0 \\ 0 & 1 & 0 & 0 & 0 & 0 & 0 & 0 & 0 & 1 & 0 \end{bmatrix}
\begin{bmatrix} 1 & 1 & 0 \\ 0 & 0 & 1 \\ 1 & 1 & 0 \\ 0 & 1 & 0 \\ 1 & 1 & 0 \\ 1 & 1 & 0 \\ 1 & 1 & 0 \\ 0 & 0 & 1 \\ 0 & 0 & 1 \\ 0 & 0 & 1 \\ 0 & 0 & 1 \end{bmatrix}
\begin{bmatrix} R_{rl} & R_{rl} & R_{rl} \\ R_{rl} & R_{rl} & R_{rl} \\ R^{(1)} & R^{(2)} & R^{(3)} \end{bmatrix}
\leq
\begin{bmatrix} c_l & c_l & c_l \\ c_l & c_l & c_l \\ c_l & c_l & c_l \end{bmatrix}$$

On channel 0, the higher fair share for each stream based on the bottleneck link's contention area is:

$$R^{ch0} = \min(R^{(1)}, R^{(2)}, R^{(3)})$$

Similarly, for channel 1:

$$\begin{bmatrix} 0 & 0 & 1 & 0 & 0 & 0 & 1 & 0 & 0 & 0 & 0 \\ 0 & 0 & 0 & 0 & 0 & 0 & 1 & 1 & 0 & 0 & 0 \\ 0 & 0 & 0 & 0 & 0 & 0 & 0 & 1 & 0 & 0 & 1 \end{bmatrix} \begin{bmatrix} 1 & 1 & 0 \\ 0 & 0 & 1 \\ 1 & 1 & 0 \\ 0 & 1 & 0 \\ 1 & 1 & 0 \\ 1 & 1 & 0 \\ 1 & 1 & 0 \\ 0 & 0 & 1 \\ 0 & 0 & 1 \\ 0 & 0 & 1 \\ 0 & 0 & 1 \end{bmatrix} \begin{bmatrix} R_{rl} & R_{rl} & R_{rl} \\ R_{rl} & R_{rl} & R_{rl} \\ R^{(1)} & R^{(2)} & R^{(3)} \end{bmatrix} \leq \begin{bmatrix} c_l & c_l & c_l \\ c_l & c_l & c_l \\ c_l & c_l & c_l \end{bmatrix}$$

On channel 1, the higher fair share for each stream based on the bottleneck link's contention area is:

$$R^{ch1} = \min(R^{(1)}, R^{(2)}, R^{(3)})$$

Finally, for channel 2:

$$\begin{bmatrix} 1 & 0 & 0 & 0 & 1 & 0 & 0 & 0 & 0 & 0 & 0 \\ 1 & 0 & 0 & 0 & 0 & 0 & 0 & 0 & 1 & 0 & 0 \end{bmatrix} \begin{bmatrix} 1 & 1 & 0 \\ 0 & 0 & 1 \\ 1 & 1 & 0 \\ 0 & 1 & 0 \\ 1 & 1 & 0 \\ 1 & 1 & 0 \\ 1 & 1 & 0 \\ 0 & 0 & 1 \\ 0 & 0 & 1 \\ 0 & 0 & 1 \\ 0 & 0 & 1 \end{bmatrix} \begin{bmatrix} R_{rl} & R_{rl} \\ R_{rl} & R_{rl} \\ R^{(1)} & R^{(2)} \end{bmatrix} \leq \begin{bmatrix} c_l & c_l \\ c_l & c_l \end{bmatrix}$$

On channel 2, the higher fair share for each stream based on the bottleneck link's contention area is:

$$R^{ch2} = \min(R^{(1)}, R^{(2)})$$

The lowest value among R^{ch0} , R^{ch1} and R^{ch2} should be taken as the higher fair share for each stream in WMN, and used as optimal transmission rate for the streams not taking the most demanded channel to reach the gateway

node:

$$R_{high} = \min(R^{ch0}, R^{ch1}, R^{ch2})$$

3.7 Model Validation

In our simulation test bed, we allow each node to have two interface cards, assigned to two different channels respectively. The way of channel assignment is to make sure any two adjacent nodes to have one channel in common, to ensure network connectivity; at the same time, we try to evenly spread all the three available channels, channel 0, channel 1, and channel 2, among all the links, to minimize collision and make best use of network bandwidth.

We simulated our computational model with UDP traffic using the ns-2 simulator. A layer, called the Channel Select layer, is added between the data link layer and the routing layer. The Channel Select layer of each node is in charge of choosing the corresponding interface to transmit packets, according to the interface its next-hop neighbor node has. Static shortest-path routing

is used. The default physical interface has transmission range of 250.0 meters and interference range of 550.0 meters. We set the `MacDataRate = 1` Mbps for each link. As a result, link capacity is $C_l = 860$ kbps. We used a `packetSize = 1500` bytes.

In order to evaluate how accurately our computational model can predict the fair share for each stream, we first use our model to determine the max-min fair share points for any given WMN and any given set of streams in that WMN, then we compare experimentally-determined fair share values with the computed values, to get the accuracy of that given case. In order to get statistical accuracy, a large amount of experiments with different topologies should be performed.

In our experiments, for a given network topology with a given set of streams, we source-rate limit each stream over a range of rates from 50 percent to 150 percent of the computed fair share rate. Plotting the results yields graphs such as Figure 3.4, which is the simulation result of the scenario shown in Figure 3.3, with each node equipped with two interface cards and a total of three channels in the whole network. The three plotted lines

are the flows from node 1 to node 0 (labeled “1>0”), from node 6 to node 0 (labeled “6>0”), and from node 11 to node 0 (labeled “11>0”). The two vertical lines labeled “r+cd” and “o+cl” are the lower fair shares computed by Collision Domain Theory and Clique Graph Theory, respectively. We refer to these graphs as “hydra plots”. When the bottleneck link of the most-demanded channel reaches its maximum throughput, the throughput of those streams crossing the bottleneck link will start decreasing. We can see in this scenario, the breaking point is very close to the predicted lower fair share by collision-domain Theory.

Next, we limit the input rate of those streams which take the more-demanded channel to reach the gateway node to this lower fair share, and keep increasing the input rate of the remaining streams. When the bottleneck link of the second most-demanded channel reaches its maximum throughput, the throughput of the set of streams crossing this bottleneck link will start decreasing. Our computational model predicts this second breaking point, or higher fair share, of the network.

For both lower fair share and higher fair share, two sets of theories are

used to represent the link contention area, Collision Domain Theory and Clique Graph Theory.

3.7.1 Chain Topology

Figure 3.4 is the hydra plot, together with vertical lines showing the lower fair share prediction using Clique-graph theory and Collision-domain Theory, for the scenario in Figure 3.3.

The lower fair share predicted using Clique-graph theory is 215000 bps, which is $C_l/4$ ($C_l=860000$ bps). The lower fair share predicted using Collision-domain theory is 430000 bps, or $C_l/2$.

Figure 3.5 is the hydra plot of the higher fair-share prediction using Collision-domain theory, by rate limiting the streams taking channel 2 to reach the gateway node to the lower fair share predicted by Collision-domain theory. The reason we take the Collision-domain lower fair share is that, from Figure 3.4, Collision-domain theory gives a more-accurate estimation than Clique-graph theory does, (i.e., the lower fair share predicted by Collision-

domain theory is closer to the breaking point than that predicted by Clique-graph theory). The reason we rate limited the streams taking channel 2 to reach the gateway node is that from the lower fair-share computation we discovered the more-demanded channel to the gateway is channel 2.

From Figure 3.4, if using Collision-domain theory to represent link contention area, the lower fair share is higher than that if using Clique-graph theory. We use the scenario in Figure 3.6 to explain why this is the case.

In Clique-graph theory the contention graph is used to represent the contention area for *all* the links. G represents all the links as a set of vertices V , and will have an edge connecting any two links within interference range. For a network with 250 meter transmission range, the interference range is 550 meters. However, different channels do not interfere with each other, so for the scenario in Figure 3.6, the link contention graph G will be as shown in Figure 3.7. Link l_1 is within interference range of l_4 . Link l_2 is within interference range of l_5 . Link l_3 is within interference range of l_6 . In Figure 3.7, the maximal clique will always have the degree of 2. This implies at any time, there could be 2 links contending with each other. Based on Clique-

graph theory, if the total available bandwidth is c_l , the fair share for each link is $B/2$.

In Collision-domain theory, a collision domain is used to represent contention area for a *certain* link. Two links contend if one endpoint of one link is within transmission range of one endpoint of the other link. Since different channels do not interfere with each other, for the scenario in Figure 3.6, each link's collision domain will only contain itself. By assuming each link has the same load, the fair share for each link is B , which is higher than the fair share computed using Clique-graph theory to represent link contention area. This effect shows up frequently in three-channel WMNs.

Besides the fact that Clique-graph theory tends to give a lower fair share than Collision-domain theory does, we also observed that in most of our simulations, the breaking points predicted by Clique-graph theory are much lower than they actually are. That is, Clique-graph theory highly underestimates the fair share. The main reason is that in our simulations we turn RTS/CTS off. We use the scenario in Figure 3.8 to illustrate why this is the reason. In Figure 3.8, node 0 is trying to send data to node 1, while node 3

is sending data to node 4.

We first look at the case when RTS/CTS is on. Node 0 sends an RTS to node 1 before it sends real data. Node 1 will not send a CTS to node 0, because it will sense the medium and, since node 3 is within interference range of node 1, node 1 will sense the medium is busy. Thus, node 0 cannot get a CTS back from node 1, and goes into Binary Exponential Backoff. Since the data length is greater than the RTS/CTS length, during the period node 0 tries to send data to node 1 and tries to get CTS back, it will experience several “collisions” as long as the data transmission from node 3 to node 4 is not finished, and its contention window will increase exponentially, which further delays its data transmission, even if link 3 becomes silent later. Therefore, when RTS/CTS is on, the traffic from node 3 to node 4 and the traffic from node 0 to node 1 cannot be carried on in parallel. This is consistent with what is predicted by Clique-graph theory, where link 0 and link 3 are within interference range.

By contrast, if RTS/CTS is off, as in our simulations, node 1 can receive data from node 0, at the same time node 3 sends data to node 4. The

throughput can be higher than is predicted by Clique-graph theory (i.e., in the case when RTS/CTS is off, Clique-graph theory under-estimates the network throughput). Note that node 1 will send an ACK even if it could sense a busy medium, since this is required by the 802.11 standard. While this ACK would interfere with any reception occurring at node 3, it will not interfere with reception at node 4, which is out of range of node 1.

3.7.2 Grid and Random Topologies

In addition to studying various chain topologies, we performed accuracy analysis for a 5x5 grid topology. The topology and hydra plot are shown in Figures 3.9 and 3.10, respectively. We also performed accuracy analysis for a 11-node random topology. The topology and hydra plot are shown in Figures 3.11 and 3.12, respectively. Note that in both grid and random topology, rate-limiting the first set of streams lead to optimistic overall throughput. Also, Collision-domain theory over-estimates the second breaking point for the grid topology, but under-estimates that for the random topology.

3.7.3 Statistical Analysis

Since experiments over a few topologies do not provide a reasonable statistical confidence in the accuracy of the models, we performed accuracy analysis for several particular topologies. We performed over 100 experiments on 5x5 grid topologies, with randomly generated streams on each run (i.e., the streams are not uniformly generated during each run). The data of our concern is the deviation of the lower and higher fair share estimation from the actual throughput breaking point of each run. Specifically, we determine the average, the standard deviation, the highest value, and the lowest value of the deviation from the computed value for 100 runs. The throughput breaking point for each run is defined as the input rate at which at least forty percent flows' throughput deviate from the input rate by at least three percent.

We perform the accuracy analysis for three estimated optimal transmission rates computed by our computational model, the lower fair shares computed by Clique-graph theory and by Collision-domain theory, the higher fair share by rate-limiting the first set of streams by the Clique-graph theory computed lower fair share, and the higher fair share by rate-limiting the first set of streams by the Collision-domain theory computed lower fair share. The

statistical results are shown in Tables 3.1 and 3.2.

	Lower OclDev	lower RcdDev
average (%)	-12.7	-4.9
standard deviation (%)	5.9	7.2
highest value (%)	-1.2	13.8
lowest value (%)	-26.9	-23.7

Table 3.1: **Accuracy Analysis for 3-Channel Networks: Lower Fair Share.**

	Higher OclDev	Higher RcdDev
average (%)	-56.3	2.3
standard deviation (%)	12.9	15.4
highest value (%)	-11.4	63.8
lowest value (%)	-80.9	-28.2

Table 3.2: **Accuracy Analysis for 3-Channel Networks: Higher Fair Share.**

From the above results, we observe that for both the lower fair share and higher fair share computation, Collision-domain theory gives a more accurate estimation than Clique-graph theory. The cause of this is as noted in the previous section: Clique-graph theory over-estimates interference in 3-channel networks. By contrast, in single-channel networks, Clique-graph theory gives a more-accurate estimate (see [8]).

3.7.4 Four-channel Scenarios

The simulation results presented above are all based on the scenarios where the total number of channels used in the network is three and each node is equipped with two interfaces. This scenario was chosen because 802.11 b/g only has three channels, and two interfaces are the most possible in our test bed. However, we wished to determine if the model was valid for more channels.

Figure 3.13 is a scenario where the number of channels available in the network is four, and each node is equipped with two interfaces. As before, the way we assign channels to each node's interfaces is to follow two principles: to make sure any two adjacent nodes to have one channel in common in order to ensure network connectivity, and to spread all four channels in the network in order to reduce collision. Figures 3.14, 3.15 and 3.16 are the hydra plots that illustrate how the computational model predicts the lower and higher fair shares for this scenario, based on our max-min fairness computation model.

As with the 3-channel case, we performed over 100 experiments on 4x4

grid topologies, with randomly generated streams on each run, determining the same data as in that case. The statistical results are shown in Tables 3.3 and 3.4, respectively.

From the above results, we observe that for both the lower fair share and higher fair share computation, both Clique-graph theory and Collision-domain theory give accurate estimation. The cause of this is that Clique-graph theory does not over-estimate interference in 4-channel networks.

	OclDev	RcdDev
average (%)	-4.3	-4.2
standard deviation (%)	9.8	9.7
highest value (%)	18.4	18.4
lowest value (%)	-26.3	-26.3

Table 3.3: **Accuracy Analysis for 4-Channel Networks: Lower Fair Share.**

	OclDev	RcdDev
average (%)	-8.1	7.4
standard deviation (%)	7.3	8.3
highest value (%)	1.8	16.3
lowest value (%)	-34.4	-51.4

Table 3.4: **Accuracy Analysis for 4-Channel Networks: Higher Fair Share.**

3.8 Generalized Max-min Fairness

As stated in Section 3.6, during our channel assignment, we try to evenly spread all the available channels among the links, to minimize collisions and make the best use of network bandwidth. However, the channel usage not only depends on the channel assignment among the network, it also depends on the link usage of the active streams. Since the streams are randomly generated, it is more likely the case that some channel becomes saturated earlier than other channels. Particularly, in a multi-channel network, it is rarely the case that:

$$R = R^{ch0} = R^{ch1} = R^{ch2}$$

with

$$R = \min(R^{ch0}, R^{ch1}, R^{ch2})$$

In other words, when some channel reaches its saturation point, there is still some extra bandwidth to use in the other channels.

In Sections 3.6 and 3.7, in order to make full use of network resource, first, we compute the lower fair share, which is obtained from the most-demanded channel. Next, we use this lower fair share to limit the input rate of those

streams which take the most-demanded channel to reach, enter or leave, the gateway node, and compute the second optimal rate, the higher fair share, the rest of the streams can achieve. However, we have to note that we actually make two assumptions for the above computation:

(1) We assume that the bottleneck link of the most-demanded channel is the same as the last-hop link to the gateway node. This assumption is based on the WMN traffic pattern: all the traffic is either starting from or designated to gateway. This makes the last hop to the gateway to become the bottleneck link in most of the cases. However, during our simulation, we find sometimes the bottleneck link of the most-demanded channel happens to be some link other than the last hop link to the gateway node. Although this situation rarely happens, (less than one percent) we do need to handle it, in order to make the computational model more general.

(2) We assume that there are only two breaking points, i.e., the computation of the lower fair share and the higher fair share should be able to cover the optimal transmission rates of all the streams. This assumption is directly related to our first assumption: since we only limit the input rate

of the streams entering or leaving from either of the two channels, which the gateway node's interfaces are assigned to, we only need two fair shares for all the streams. However, if we are not going to rate-limit the streams only based on these two channels, we should be able to compute fair shares repeatedly till all the streams are assigned optimal transmission rates.

Our generalized max-min-fairness computational model includes the following three steps:

(1) Compute the lower fair share, which is obtained from the most-demanded channel. This step is the same as the computation of fair throughput share in Section 3.5;

(2) We use the lower fair share obtained from step (1) to limit the input rate of those streams crossing the bottleneck link's contention area of the most-demanded channel in the network in step (1), and compute the higher fair share from the new most-demanded channel.

(3) If, after step (2), not all the streams have been assigned to an optimal

transmission rate, we use the higher fair share obtained from step (2) to limit the input rate of those streams crossing the bottleneck link's contention area of the most-demanded channel in step (2), and compute the next higher fair share from the new most-demanded channel. Step (3) should be repeated until all the streams are assigned to an optimal transmission rate.

Generally, assuming there are totally I channels available in the WMN, Equations (3.16), (3.17) and (3.18) still hold:

$$R_{rl} = \min(R^{ch1}, R^{ch2}, \dots, R^{chI})$$

$$R_{low} = R_{rl}$$

$$ch_{rl} = chi, \quad \text{for } 1 \leq i \leq I \quad \text{and} \quad R^{chi} = R_{rl}$$

R_{low} is the lower fair share, ch_{rl} is the most-demanded channel, from which we get the bottleneck link's contention area of the most-demanded channel:

$$M_{rl} = M_{BN}^{ch_{rl}} \tag{3.20}$$

Recall Equation(3.19):

$$M_j^m LR \leq C_l$$

In order to compute higher fair shares for all the streams in the network, Equation(3.19) should be repeatedly applied to all the channels in the network, along with the following two different sets of \mathbf{R} :

$$R(s_k)=R_{rl}, \quad \text{when } s_k \text{ crossing } M_{rl}$$

$$R(s_k)=R, \quad \text{when } s_k \text{ not crossing } M_{rl}$$

We take the scenario depicted on Figure 3.17 (same scenario as in Figure 3.3), to illustrate the higher-fair-share computation process.

$$\mathbf{L} = \begin{bmatrix} 1 & 1 & 0 \\ 0 & 0 & 1 \\ 1 & 1 & 0 \\ 0 & 1 & 0 \\ 1 & 1 & 0 \\ 1 & 1 & 0 \\ 1 & 1 & 0 \\ 0 & 0 & 1 \\ 0 & 0 & 1 \\ 0 & 0 & 1 \\ 0 & 0 & 1 \end{bmatrix}$$

Based on Clique-graph theory, $M[i, j]$ will have three different sets of values of maximal cliques for channel 0, channel 1, and channel 2:

$$M^{ch0} = \begin{bmatrix} 0 & 0 & 0 & 1 & 0 & 1 & 0 & 0 & 0 & 0 & 0 \\ 0 & 1 & 0 & 0 & 0 & 1 & 0 & 0 & 0 & 0 & 0 \\ 0 & 1 & 0 & 0 & 0 & 0 & 0 & 0 & 0 & 1 & 0 \end{bmatrix}$$

$$M^{ch1} = \begin{bmatrix} 0 & 0 & 1 & 0 & 0 & 0 & 1 & 0 & 0 & 0 & 0 \\ 0 & 0 & 0 & 0 & 0 & 0 & 1 & 1 & 0 & 0 & 0 \\ 0 & 0 & 0 & 0 & 0 & 0 & 0 & 1 & 0 & 0 & 1 \end{bmatrix}$$

$$M^{ch2} = \begin{bmatrix} 1 & 0 & 0 & 0 & 1 & 0 & 0 & 0 & 0 & 0 & 0 \\ 1 & 0 & 0 & 0 & 0 & 0 & 0 & 0 & 1 & 0 & 0 \end{bmatrix}$$

After first-step computation, the lowest throughput share is obtained from channel 2, i.e.,

$$R_{rl} = \min(R^{ch0}, R^{ch1}, R^{ch2}) = R^{ch2}$$

$$R_{low} = R_{rl}$$

$$ch_{rl} = ch2$$

In order to get M_{rl} , we look closely to the process of applying Equation (3.19)

to channel 2:

Applying Equation (3.19) to the first maximal clique:

$$\begin{bmatrix} 1 & 0 & 0 & 0 & 1 & 0 & 0 & 0 & 0 & 0 & 0 & 0 \end{bmatrix} \begin{bmatrix} 1 & 1 & 0 \\ 0 & 0 & 1 \\ 1 & 1 & 0 \\ 0 & 1 & 0 \\ 1 & 1 & 0 \\ 1 & 1 & 0 \\ 1 & 1 & 0 \\ 0 & 0 & 1 \\ 0 & 0 & 1 \\ 0 & 0 & 1 \\ 0 & 0 & 1 \end{bmatrix} \begin{bmatrix} R^{(1)} \\ R^{(1)} \\ R^{(1)} \end{bmatrix} \leq \begin{bmatrix} c_l \end{bmatrix}$$

which lead to:

$$R^{(1)} = \frac{c_l}{4}$$

Applying Equation (3.19) to the second maximal clique:

$$\begin{bmatrix} 1 & 0 & 0 & 0 & 0 & 0 & 0 & 0 & 0 & 1 & 0 & 0 \end{bmatrix} \begin{bmatrix} 1 & 1 & 0 \\ 0 & 0 & 1 \\ 1 & 1 & 0 \\ 0 & 1 & 0 \\ 1 & 1 & 0 \\ 1 & 1 & 0 \\ 1 & 1 & 0 \\ 0 & 0 & 1 \\ 0 & 0 & 1 \\ 0 & 0 & 1 \\ 0 & 0 & 1 \end{bmatrix} \begin{bmatrix} R^{(2)} \\ R^{(2)} \\ R^{(2)} \end{bmatrix} \leq \begin{bmatrix} c_l \end{bmatrix}$$

which lead to:

$$R^{(2)} = \frac{c_l}{3}$$

Hence, the bottleneck link's contention area of channel 2 is the first maximal clique:

$$\begin{bmatrix} 1 & 0 & 0 & 0 & 1 & 0 & 0 & 0 & 0 & 0 & 0 \end{bmatrix}$$

And the streams crossing this contention area are stream 0 and stream 1.

Recall Equation(3.19):

$$M_j^m LR \leq C_l$$

In order to compute higher fair share, Equation(3.19) should be applied to all the three channels in the network, along with the following two different sets of \mathbf{R} :

$$R(s_0)=R(s_1)=R_{rl}$$

since s_0 and s_1 cross M_{rl} , and

$$R(s_2)=R$$

since s_2 is not crossing M_{rl} .

For channel 0:

$$\begin{bmatrix} 0 & 0 & 0 & 1 & 0 & 1 & 0 & 0 & 0 & 0 & 0 \\ 0 & 1 & 0 & 0 & 0 & 1 & 0 & 0 & 0 & 0 & 0 \\ 0 & 1 & 0 & 0 & 0 & 0 & 0 & 0 & 0 & 1 & 0 \end{bmatrix}
\begin{bmatrix} 1 & 1 & 0 \\ 0 & 0 & 1 \\ 1 & 1 & 0 \\ 0 & 1 & 0 \\ 1 & 1 & 0 \\ 1 & 1 & 0 \\ 1 & 1 & 0 \\ 0 & 0 & 1 \\ 0 & 0 & 1 \\ 0 & 0 & 1 \\ 0 & 0 & 1 \end{bmatrix}
\begin{bmatrix} R_{rl} & R_{rl} & R_{rl} \\ R_{rl} & R_{rl} & R_{rl} \\ R^{(1)} & R^{(2)} & R^{(3)} \end{bmatrix}
\leq
\begin{bmatrix} c_l & c_l & c_l \\ c_l & c_l & c_l \\ c_l & c_l & c_l \end{bmatrix}$$

On channel 0, the higher fair share for each stream based on the bottleneck link's contention area is:

$$R^{ch0} = \min(R^{(1)}, R^{(2)}, R^{(3)})$$

Similarly, for channel 1:

$$\begin{bmatrix} 0 & 0 & 1 & 0 & 0 & 0 & 1 & 0 & 0 & 0 & 0 \\ 0 & 0 & 0 & 0 & 0 & 0 & 1 & 1 & 0 & 0 & 0 \\ 0 & 0 & 0 & 0 & 0 & 0 & 0 & 1 & 0 & 0 & 1 \end{bmatrix} \begin{bmatrix} 1 & 1 & 0 \\ 0 & 0 & 1 \\ 1 & 1 & 0 \\ 0 & 1 & 0 \\ 1 & 1 & 0 \\ 1 & 1 & 0 \\ 1 & 1 & 0 \\ 0 & 0 & 1 \\ 0 & 0 & 1 \\ 0 & 0 & 1 \\ 0 & 0 & 1 \end{bmatrix} \begin{bmatrix} R_{rl} & R_{rl} & R_{rl} \\ R_{rl} & R_{rl} & R_{rl} \\ R^{(1)} & R^{(2)} & R^{(3)} \end{bmatrix} \leq \begin{bmatrix} c_l & c_l & c_l \\ c_l & c_l & c_l \\ c_l & c_l & c_l \end{bmatrix}$$

On channel 1, the higher fair share for each stream based on the bottleneck link's contention area is:

$$R^{ch1} = \min(R^{(1)}, R^{(2)}, R^{(3)})$$

Similarly, for channel 2:

$$\begin{bmatrix} 1 & 0 & 0 & 0 & 1 & 0 & 0 & 0 & 0 & 0 & 0 & 0 \\ 1 & 0 & 0 & 0 & 0 & 0 & 0 & 0 & 1 & 0 & 0 & 0 \end{bmatrix} \begin{bmatrix} 1 & 1 & 0 \\ 0 & 0 & 1 \\ 1 & 1 & 0 \\ 0 & 1 & 0 \\ 1 & 1 & 0 \\ 1 & 1 & 0 \\ 1 & 1 & 0 \\ 0 & 0 & 1 \\ 0 & 0 & 1 \\ 0 & 0 & 1 \\ 0 & 0 & 1 \end{bmatrix} \begin{bmatrix} R_{rl} & R_{rl} \\ R_{rl} & R_{rl} \\ R^{(1)} & R^{(2)} \end{bmatrix} \leq \begin{bmatrix} c_l & c_l \\ c_l & c_l \end{bmatrix}$$

On channel 2, the higher fair share for each stream based on the bottleneck link's contention area is:

$$R^{ch2} = \min(R^{(1)}, R^{(2)})$$

The lowest value among R^{ch0} , R^{ch1} and R^{ch2} should be taken as the higher

fair share, and used as optimal transmission rate for the streams not crossing the bottleneck link's contention area of the most-demanded channel in the step of computing lower fair share. In this scenario, stream 2 is the only stream left, and is assigned this higher fair share.

$$R_{high} = \min(R^{ch0}, R^{ch1}, R^{ch2})$$

3.8.1 Validation of Generalized Model

We performed accuracy analysis for a 5x4 grid topology. The topology is shown in Figure 3.18. Figures 3.19, 3.20 and 3.21 are the hydra plots to illustrate how the generalized max-min fairness computational model predicts the lower and higher fair shares for this scenario.

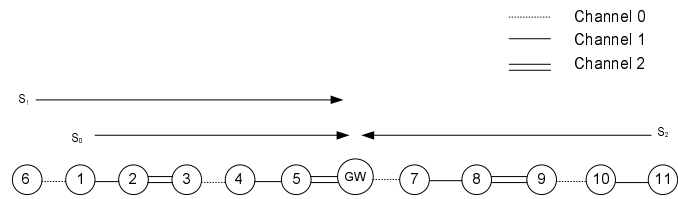

Figure 3.3: A Multi-channel WMN with Three Streams.

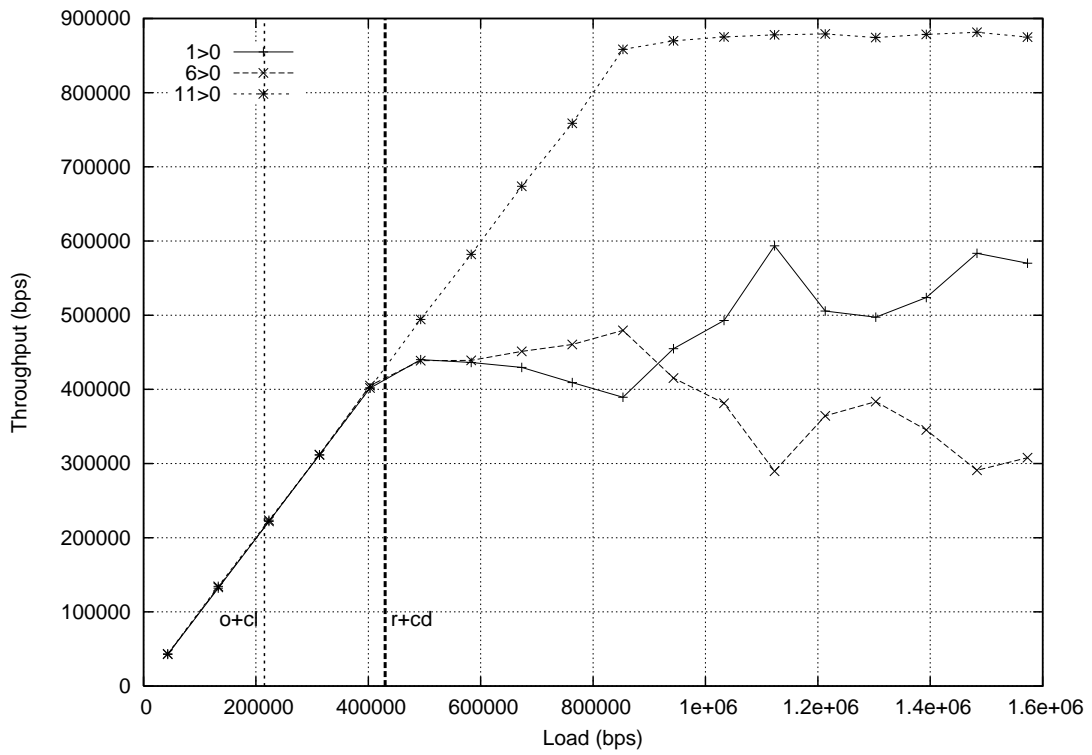

Figure 3.4: RCD and OCL Lower Fair Shares (for Chain Topology in Figure 3.3).

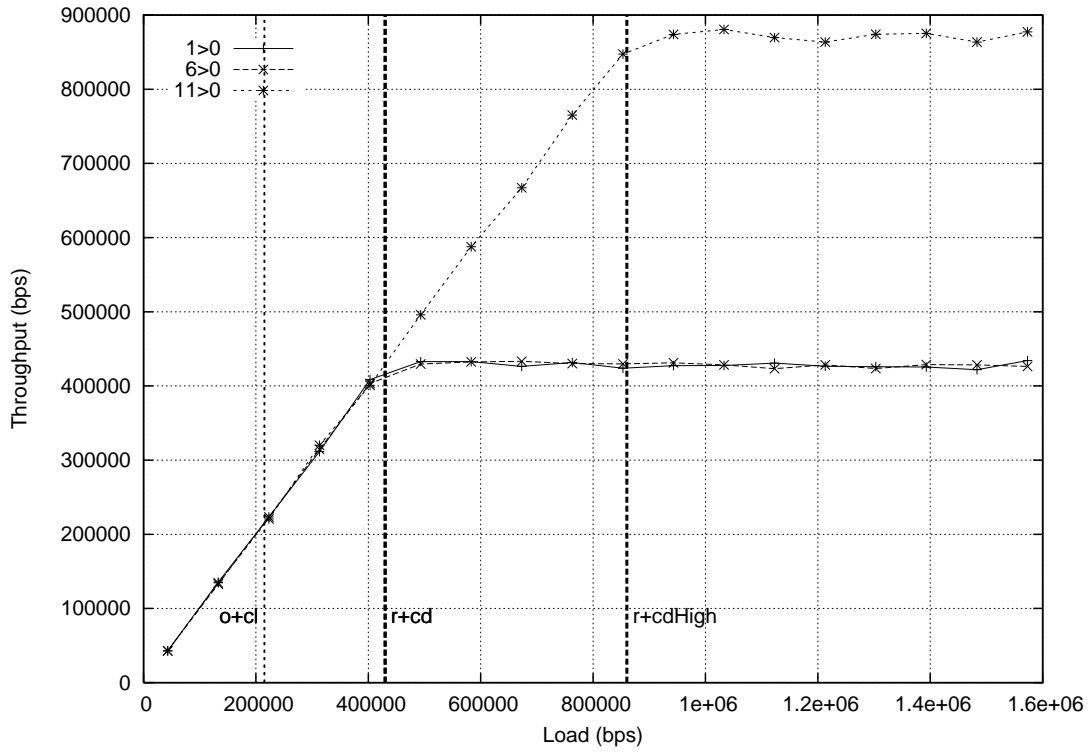

Figure 3.5: RCD Higher Fair Share (for Chain Topology in Figure 3.3).

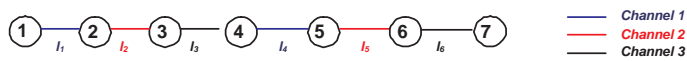

Figure 3.6: Multi-channel Chain Topology.

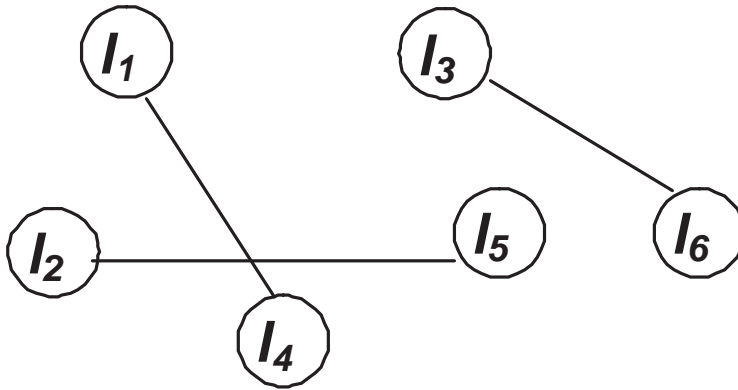

Figure 3.7: Contention Graph G for Scenario in Figure 3.6.

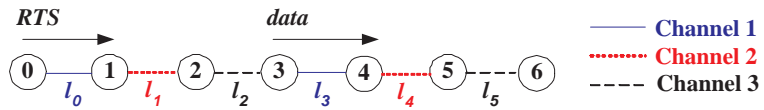

Figure 3.8: Multi-channel Chain with RTS/CTS On.

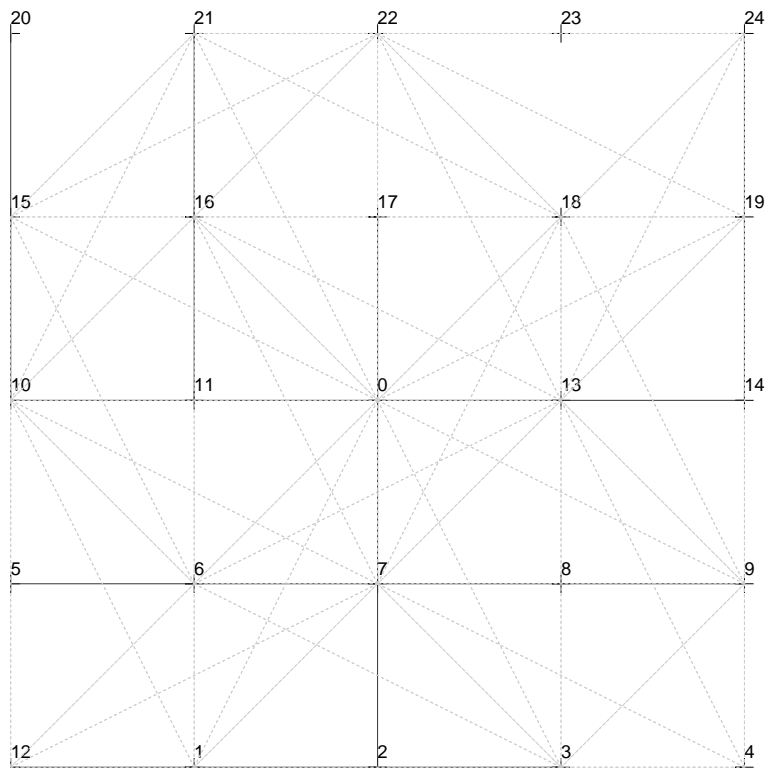

Figure 3.9: **3-Channel-2-Interface 5x5 Grid Topology.**

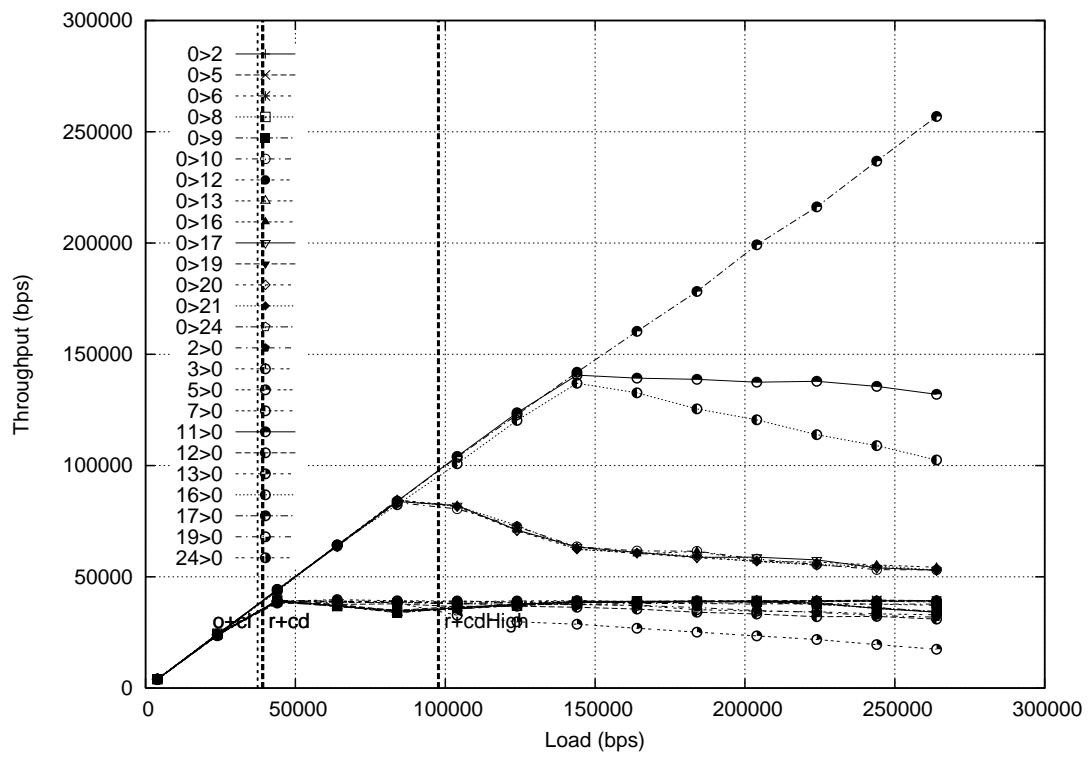

Figure 3.10: RCD Higher Fair Share.

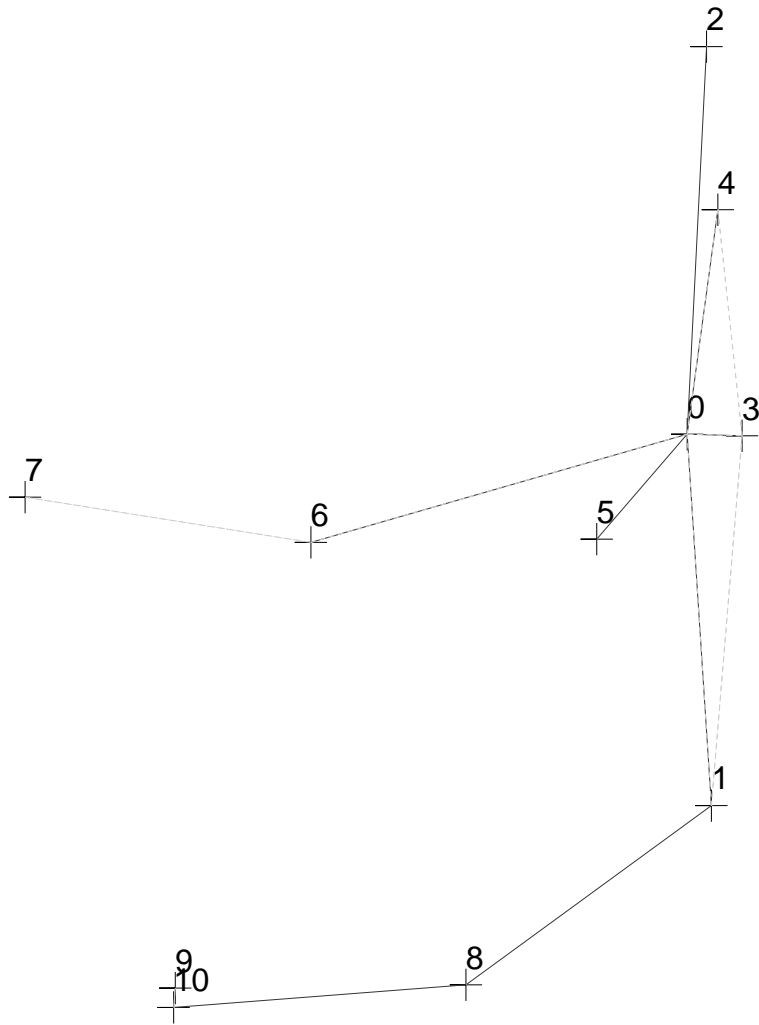

Figure 3.11: **3-Channel-2-Interface Random Topology.**

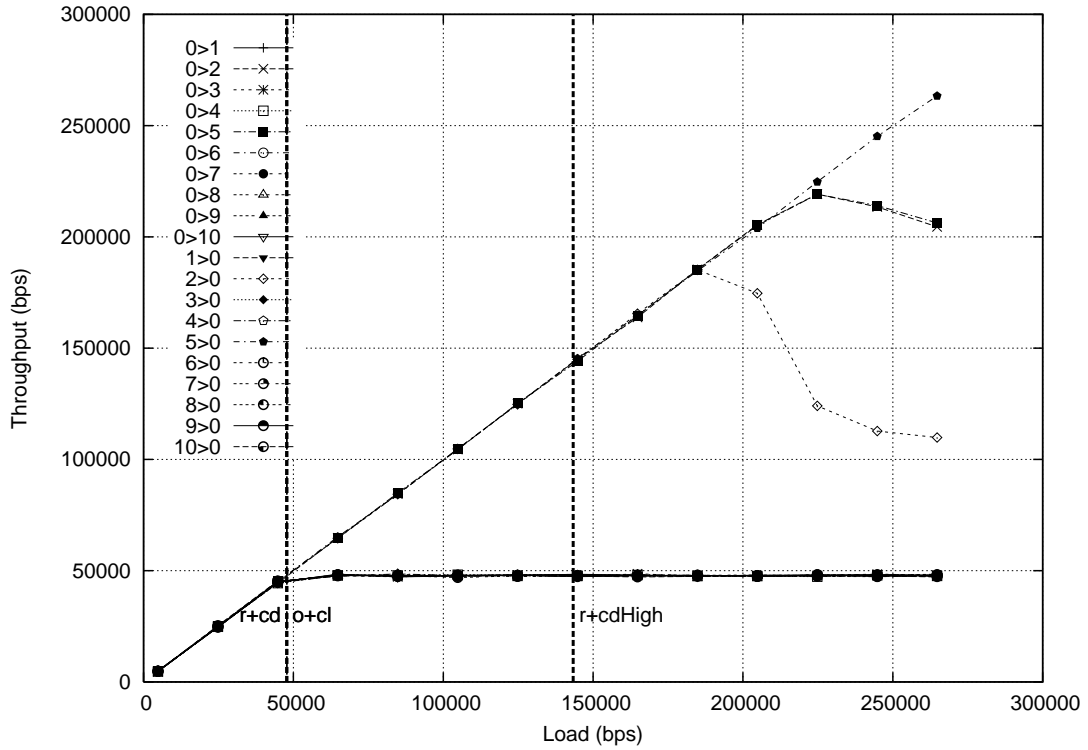

Figure 3.12: RCD Higher Fair Share.

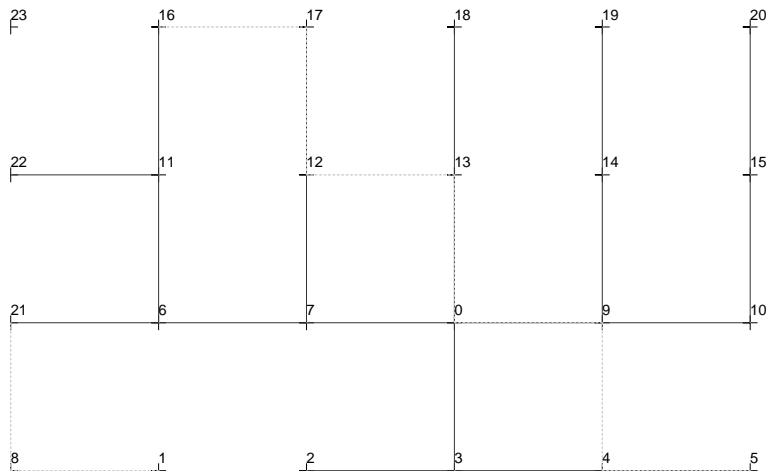

Figure 3.13: 4-Channel-2-Interface 6x4 Grid Topology.

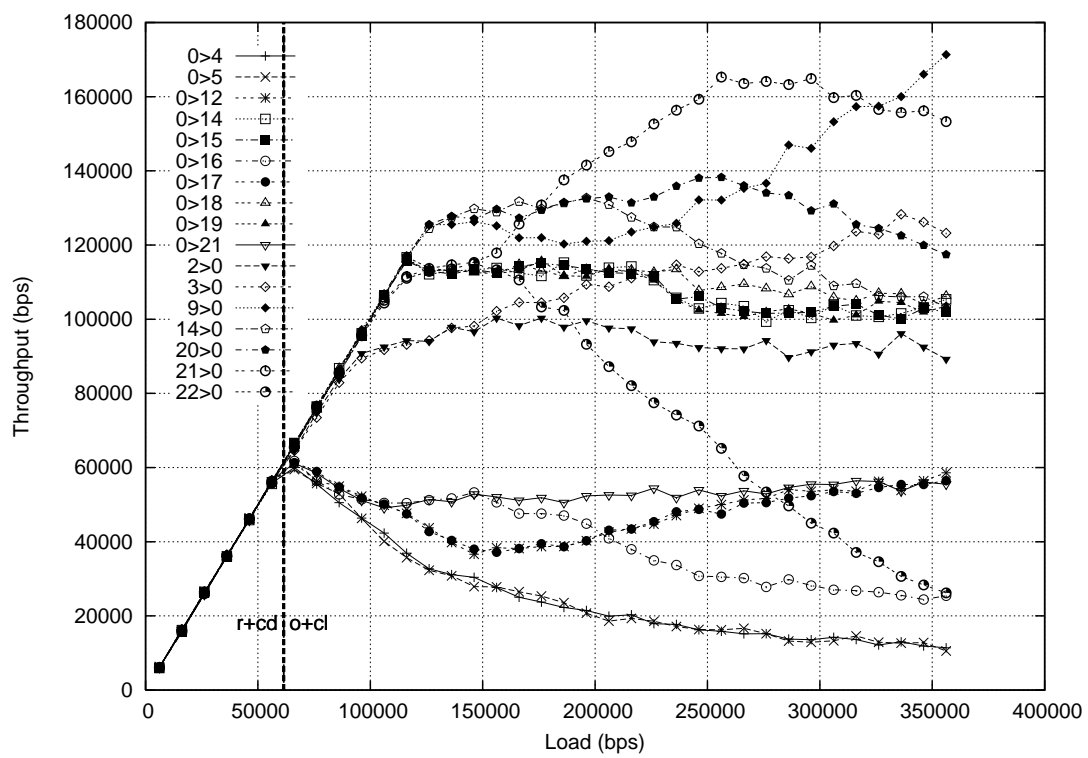

Figure 3.14: RCD and OCL Lower Fair Shares.

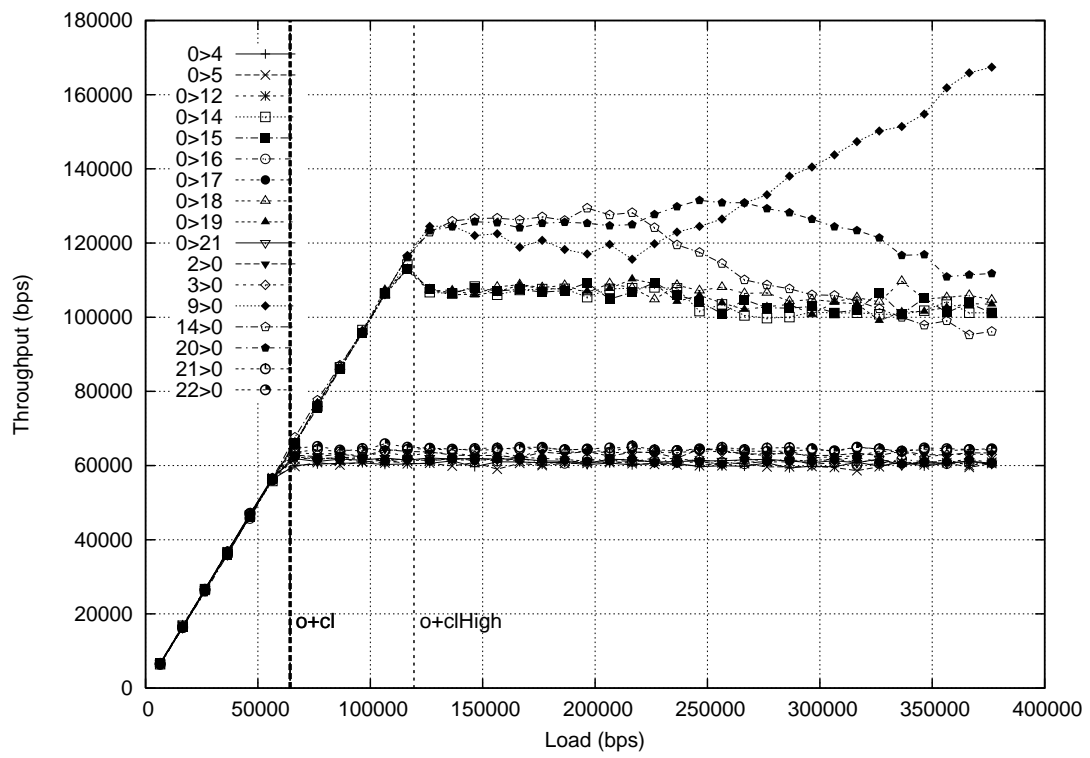

Figure 3.15: OCL Higher Fair Share.

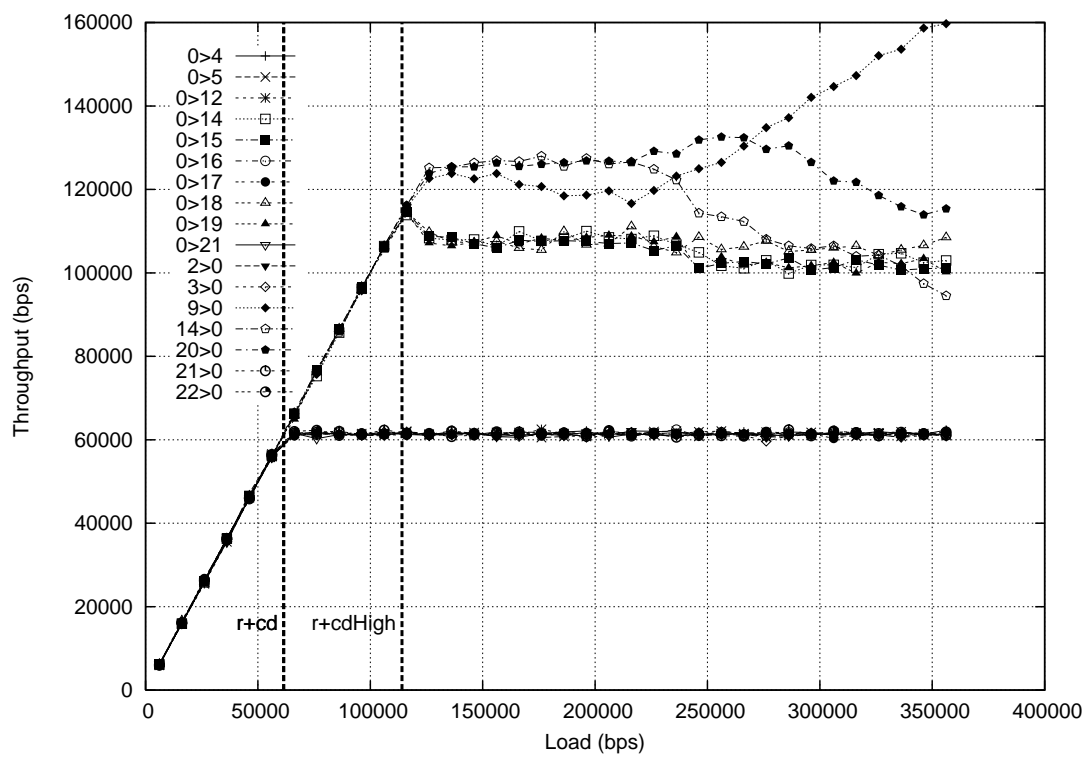

Figure 3.16: RCD Higher Fair Share.

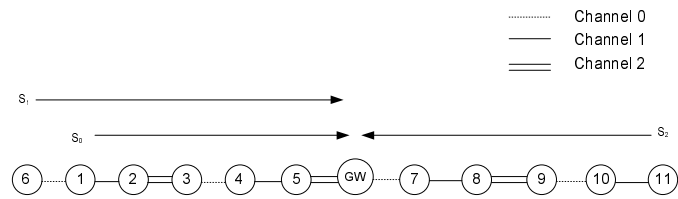

Figure 3.17: **A Multi-channel WMN with Three Streams.**

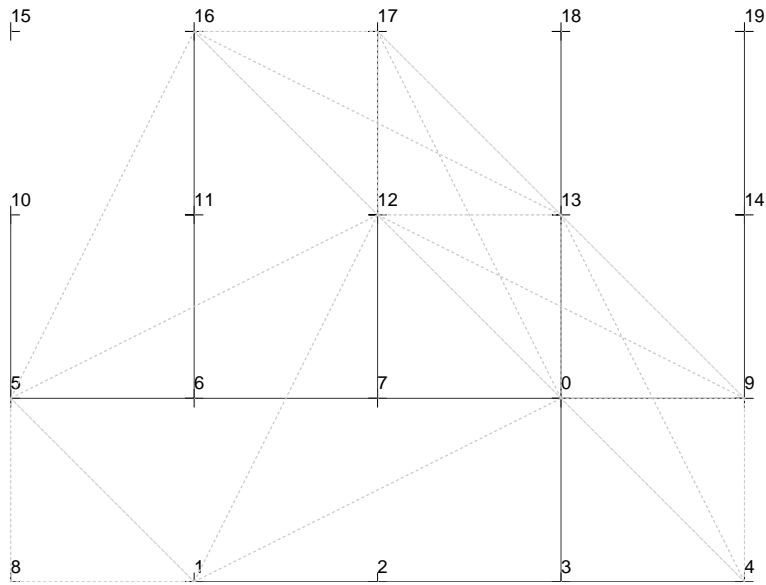

Figure 3.18: **4-Channel-2-Interface 5x4 Grid Topology.**

As before, we performed over 100 experiments with randomly generated streams. The statistical result is shown in Tables 3.5, and 3.6, respectively. Note that we only preformed accuracy analysis for the lower fair share and the first higher fair share, since the occurrence of the third breaking point is less than 1 percent. That is, among 125 experiments, only 2 runs have the third breaking point.

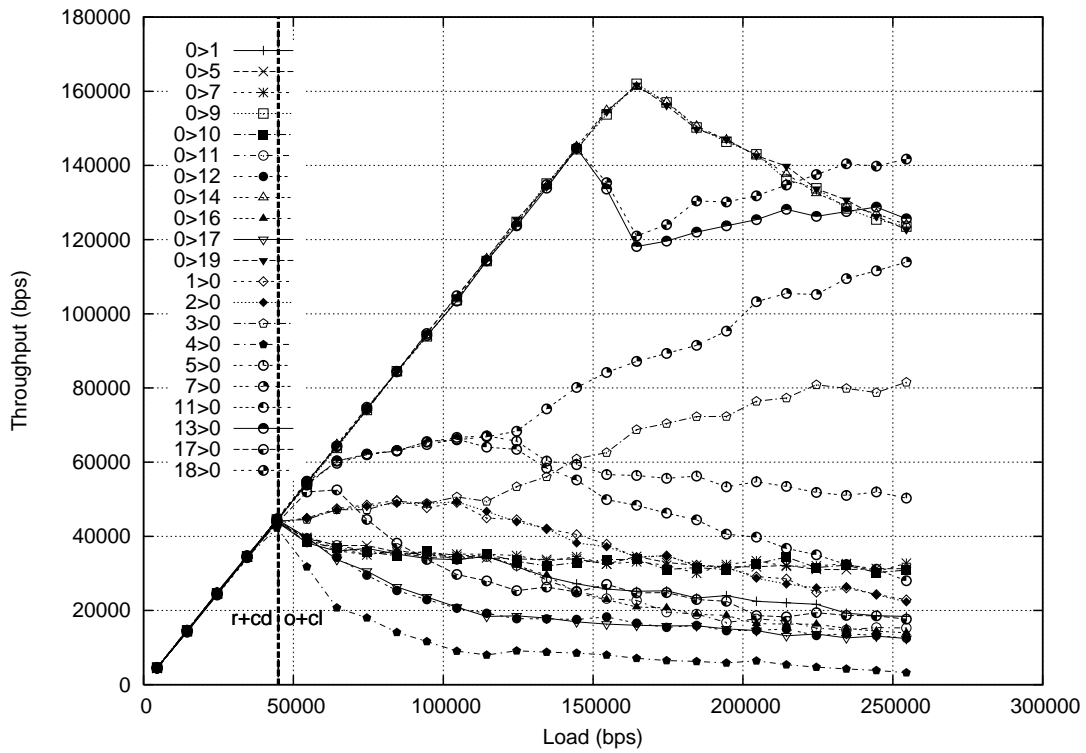

Figure 3.19: RCD and OCL Lower Fair Shares.

	OclDev	RcdDev
average (%)	-4.0	-3.9
standard deviation (%)	12.0	12.0
highest value (%)	23.2	23.2
lowest value (%)	-39.6	-39.6

Table 3.5: Accuracy Analysis for 4-Channel Networks: Lower Fair Share.

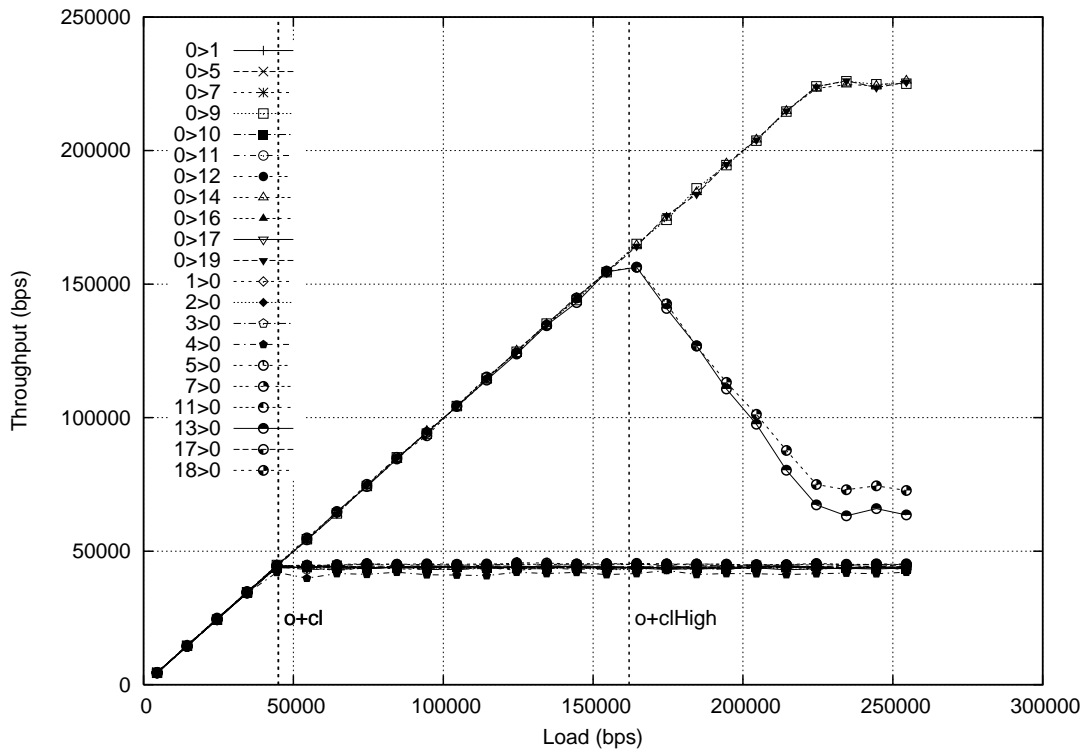

Figure 3.20: OCL Higher Fair Share.

	OclDev	RcdDev
average (%)	-3.0	-2.5
standard deviation (%)	7.5	8.9
highest value (%)	9.6	21.5
lowest value (%)	-31.4	-53.2

Table 3.6: Accuracy Analysis for 4-Channel Networks: Higher Fair Share.

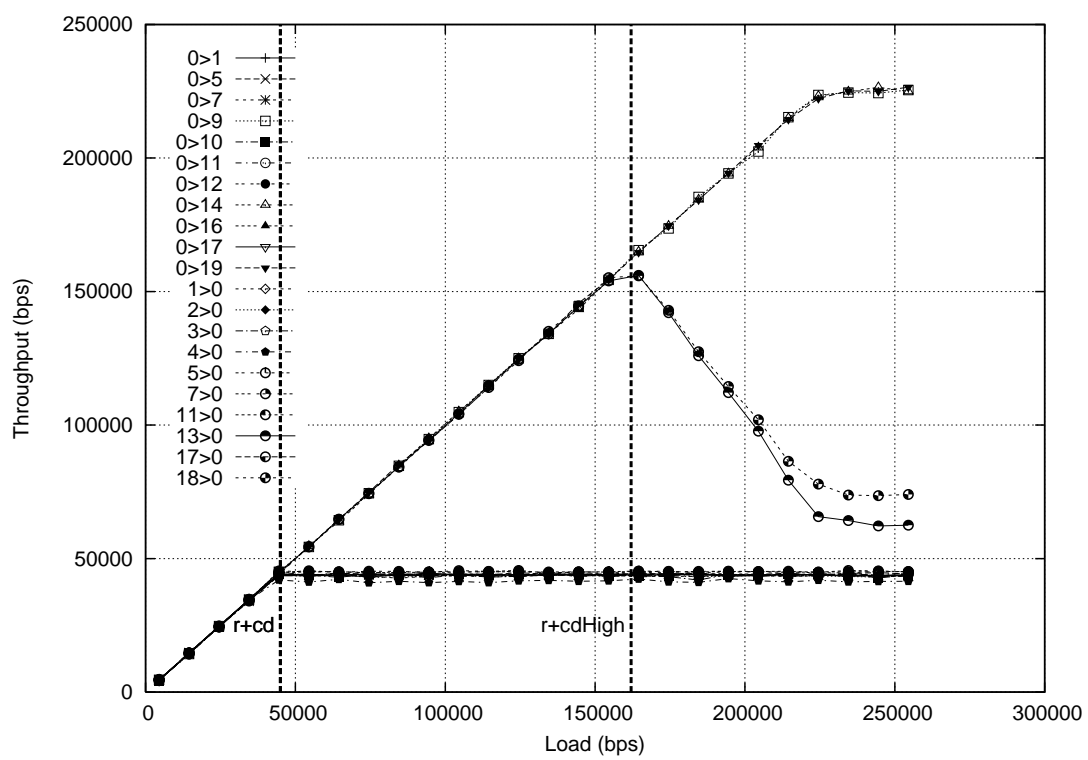

Figure 3.21: RCD Higher Fair Share.

Chapter 4

Achieving Fairness in Multi-channel WMN

Jakubczak et al. [8] present a three-step explicit rate-control algorithm to address the fairness problem in single-channel wireless mesh network. Specifically, the algorithm contains three parts: a distributed algorithm for the delivery of stream-activity information, by piggybacking the information data on data frames, a computational task performed at each node for determining the fair-share rate for each stream, and a self-policing algorithm for limiting the fair-share rate to the computed rate. This rate-control algorithm has the advantage that no modifications are required to the underlying 802.11 MAC.

In single-channel networks, in order to make stream-origin nodes aware of the network state, the “snooping” idea is adopted. A stream-origin node can hear traffic being transmitted by its next-hop neighbor, even though it does not relay the packet, thus getting more up-to-date activity information of its down-stream nodes from the piggybacked data packets.

We wished to adopt the same rate-control scheme, to achieve max-min fairness in multi-channel wireless mesh networks. However, the “snooping” idea in single-channel networks does not work well in multi-channel case, since the next-hop neighbor uses a different channel to forward the packet than the channel the stream-origin node uses. In practical networks, most traffic is, TCP, and we take advantage of TCP’s bi-directional traffic feature, so a stream-origin node can get more up-to-date activity information from the ACK packets. We wanted to see if this approach works in multi-channel networks, but accuracy analysis is not our main intention.

We have the same environment settings as in the previous chapter. Static shortest-path routing is used. The default physical interface has transmis-

sion range of 250.0 meters and interference range of 550.0 meters. We set the `MacDataRate = 1 Mbps`, link capacity $C_l = 860$ kbps, `packetSize = 1500` bytes.

Figures 4.2 and 4.3 show the simulation result in a 8-node chain topology, shown in Figure 4.1, without and with our fairness algorithm, respectively. Each simulation is 125 seconds long and is divided into 5 equally length intervals. The stream activity changes are manually scheduled during each interval as follows:

- interval 1: 3 to 0, 7 to 0
- interval 2: 0 to 2, 3 to 0, 4 to 0, 6 to 0, 7 to 0
- interval 3: 3 to 0, 4 to 0, 6 to 0, 7 to 0
- interval 4: 3 to 0, 4 to 0
- interval 5: 3 to 0, 4 to 0, 7 to 0

We can see Figure 4.2 shows poor fairness (big difference between throughput of different streams). Figure 4.3 illustrates the active streams are nicely

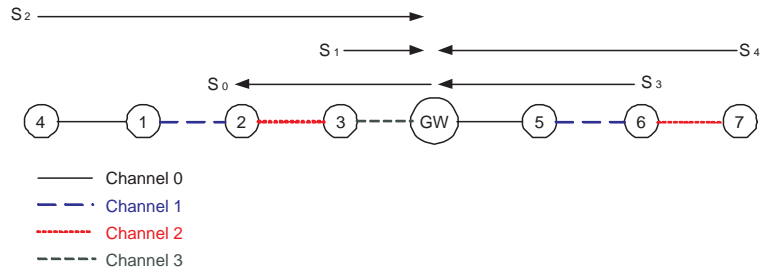

Figure 4.1: 4-Channel Chain Topology with 5 TCP Streams.

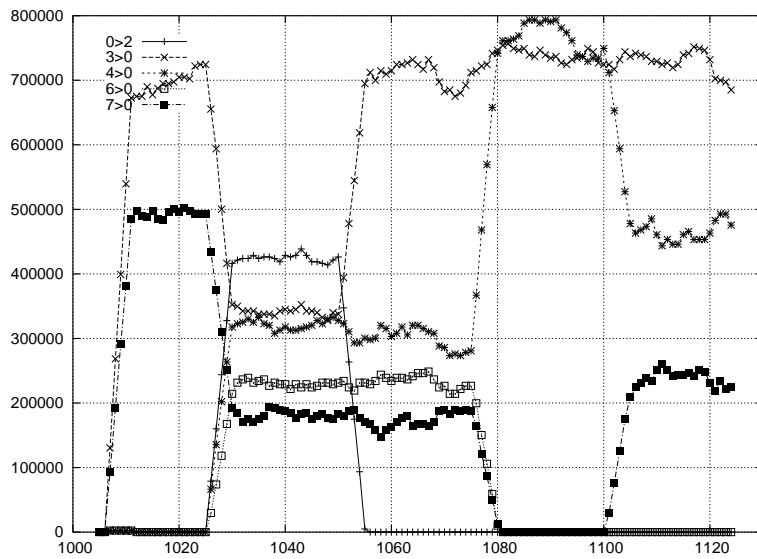

Figure 4.2: Simulation Results for Chain Topology (TCP) without Fairness Algorithm (for Figure 4.1).

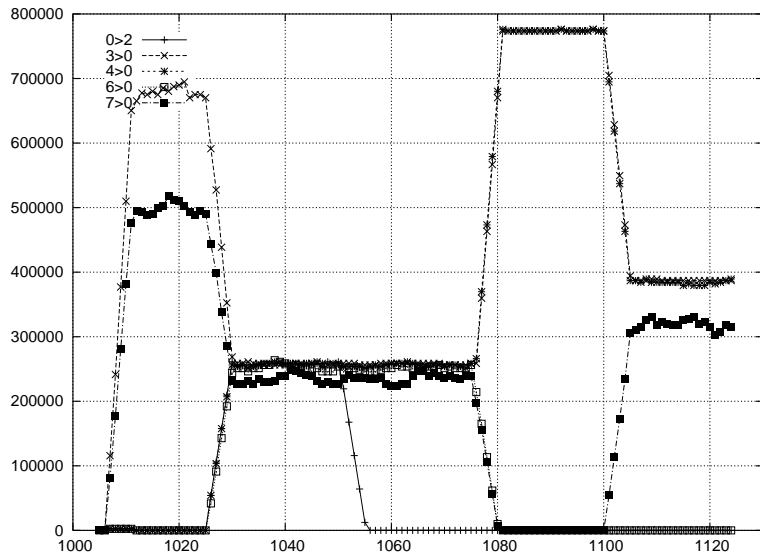

Figure 4.3: Simulation Results for Chain Topology (TCP) with Fairness Algorithm (for Figure 4.1).

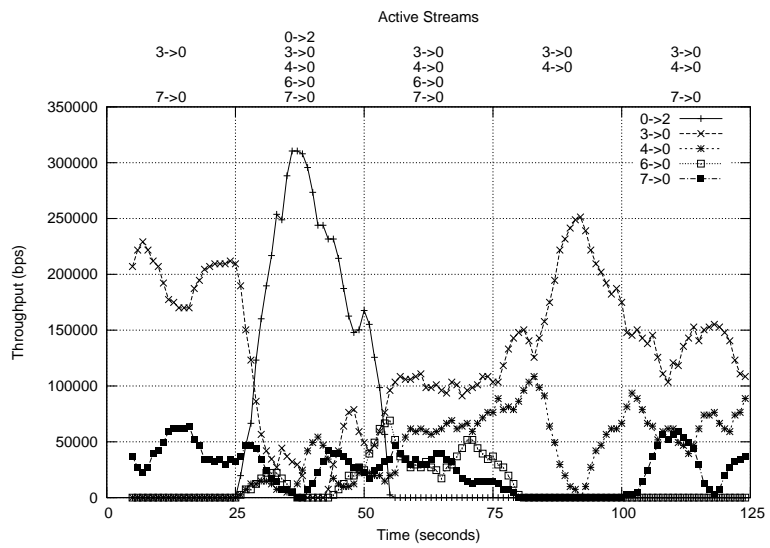

Figure 4.4: Simulation Results for A Single-channel Chain Topology (TCP) without Fairness Algorithm.

controlled by max-min fairness, and have very small variations.

If we compare Figure 4.2 with Figure 4.4, which shows simulation result in a single-channel network without the fairness algorithm applied and with the same topology as in Figure 4.1, we notice that absence of the fairness mechanism causes severe throughput starvation for some streams in single-channel networks, but only causes unfair throughput among streams in multi-channel case. This is because in single-channel networks, when the number of nodes increases, interference between nodes becomes serious in a short time, while in multi-channel networks, this interference is alleviated by increasing the number of channels in the network, and assigning the channels among nodes in an alternative way.

We also find that in some grid topologies in multi-channel networks, increasing the number of channels does not alleviate the interference between nodes too much, to avoid some streams' throughput starvation. Figures 4.6 and 4.7 show the simulation result in a 25-node grid topology, shown in Figure 4.5, without and with our fairness algorithm, respectively. Each simulation is 150 seconds long and is divided into 3 equal-length intervals. The stream

activity changes are manually scheduled during each interval as follows:

- interval 1: 0 to 2, 3 to 0, 4 to 0, 7 to 0, 0 to 22, 23 to 0
- interval 2: 0 to 2, 3 to 0, 4 to 0, 6 to 0, 7 to 0, 17 to 0, 0 to 22, 23 to 0
- interval 3: 0 to 2, 3 to 0, 4 to 0, 6 to 0, 7 to 0, 0 to 22, 23 to 0

Figure 4.6 shows poor fairness (big difference between throughput of different streams, throughput starvation of stream 4 to 0). Figure 4.7 illustrates the active streams are nicely controlled by max-min fairness, and have very small variations.

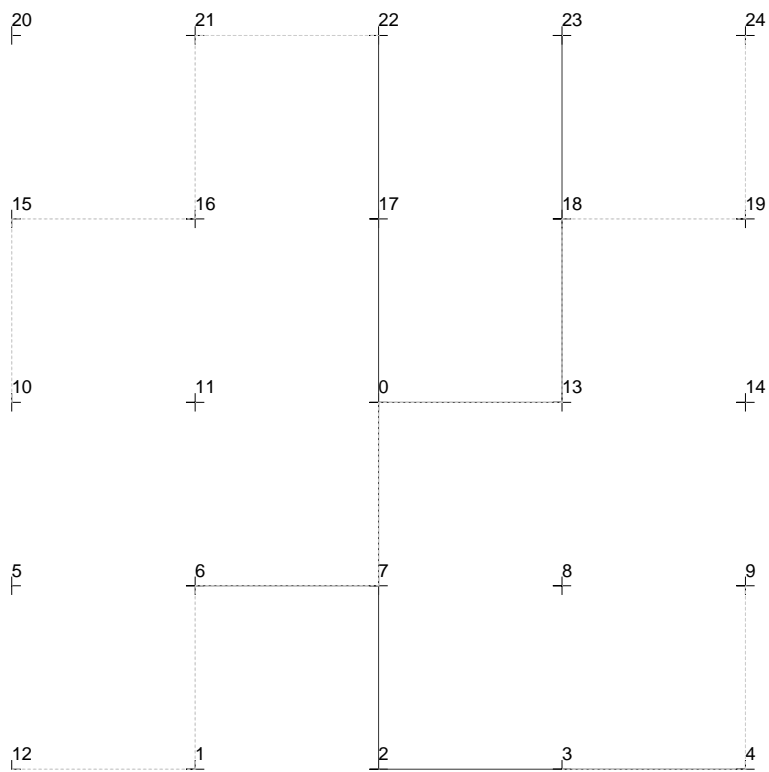

Figure 4.5: **3-Channel Grid Topology with 8 TCP Streams.**

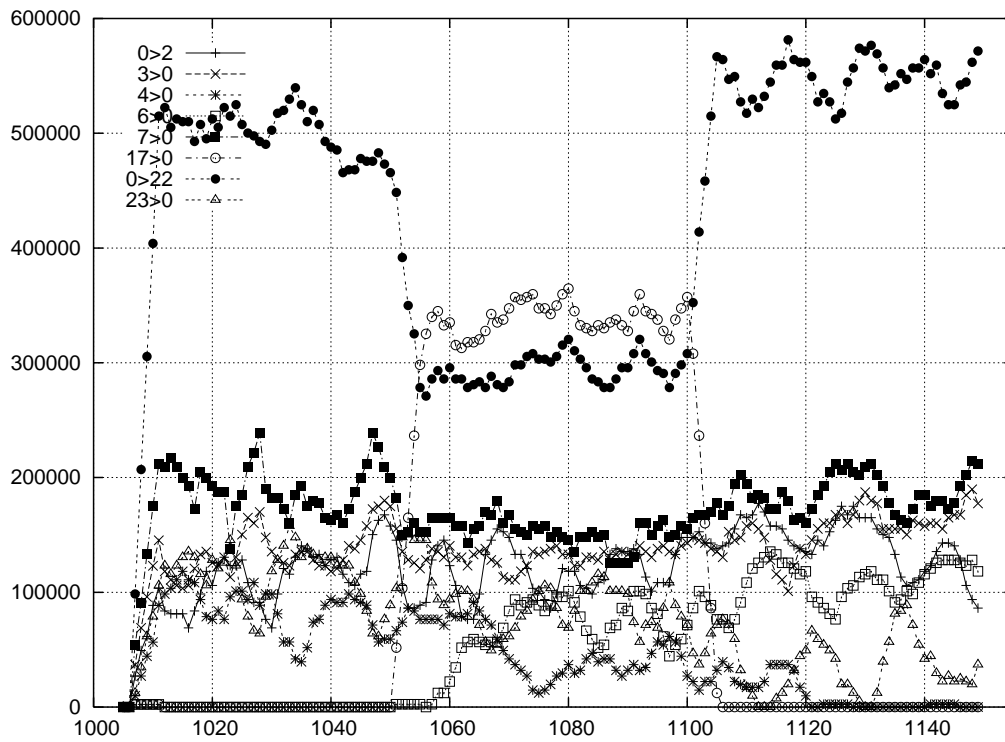

Figure 4.6: Simulation Results for Grid Topology (TCP) without Fairness Algorithm (for Figure 4.5).

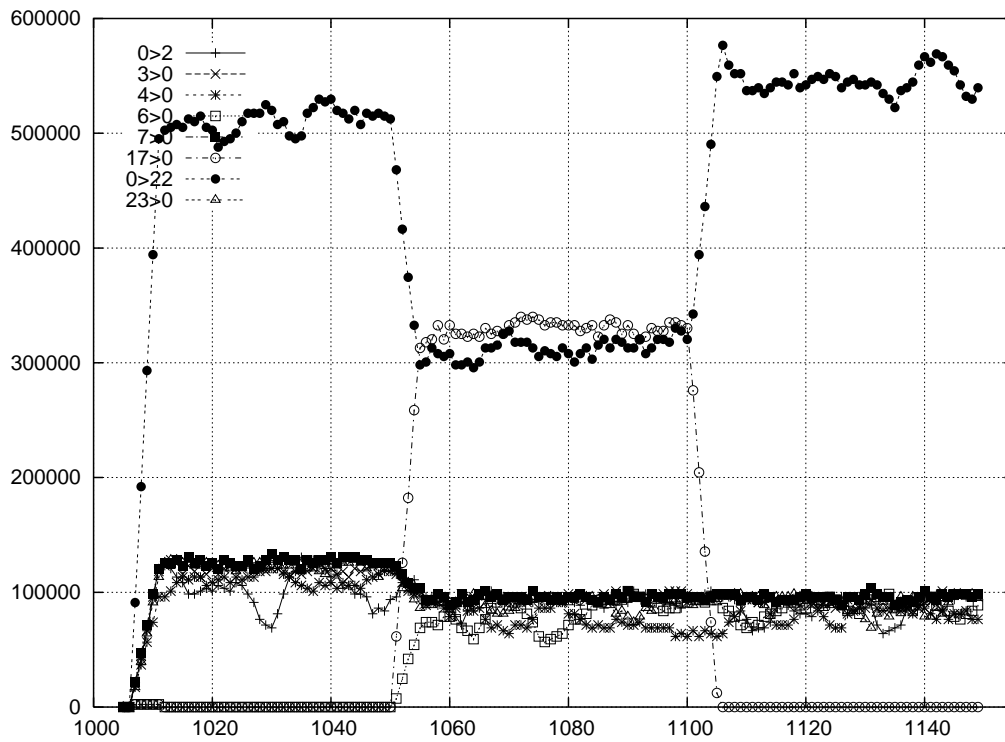

Figure 4.7: Simulation Results for Grid Topology (TCP) with Fairness Algorithm (for Figure 4.5).

Chapter 5

Conclusion

In this thesis we presented a novel multi-channel computation model. We studied the accuracy of this model, showing that it works best when using underlying Collision-domain theory, rather than Clique-graph theory, especially for three-channel networks. We also showed that the source-rate fairness mechanism of Jakubczak et al. [8] seems to work in multi-channel case when using TCP traffic.

5.1 Future Work

We wish to extend the current work in the following directions:

- (1) Determine the model accuracy when changing number of interfaces for each node.
- (2) Perform accuracy analysis on networks with more than four channels.
- (3) Analyze and eliminate possible errors in the current model, in order to improve accuracy.

Bibliography

- [1] N. Ahmed and S. Keshav. A Successive Refinement Approach to Wireless Infrastructure Network Deployment. In *Proceedings of IEEE WCNC, 2006.(WCNC,2005)*, April 2006.
- [2] E. Amir and H. Balakrishnan. An Evaluation of the Metricom Ricochet Wireless Network. In *cs 294-7 class project, Department of Electrical Engineering and Computer Science University of California at Berkeley*, 1996.
- [3] R. Bruno, M. Conti, and E. Gregori. Mesh Networks: Commodity Multihop Ad Hoc Networks. In *IEEE Communications'05*, 2005.
- [4] Vileta Gambiroza, Bahareh Sadeghi, and Edward W. Knightly. End-to-End Performance and Fairness in Multihop Wireless Backhaul Networks. In *MOBICOM'04*, Philadelphia, Pennsylvania, USA, September 2004.

- [5] J. J. Garcia-Luna-Aceves, C. L. Fullmer, E. Madruga, and T. Frivold D. Beyer. Wireless Internet Gateways (WINGS). In *Proceedings of MILCOM'97, vol. 3, pp1271-1276, 1997, 1997*.
- [6] Rajarshi Gupta and Jean Walrand. Approximating Maximal Cliques in Ad-hoc Networks. In *Dept. of EECS, University of California, Berkeley, CA, USA*.
- [7] M. Heusse, F. Rousseau, G Berger-Sabbatel, and A. Duda. Performance Anomaly of 802.11b. In *Proceedings of Infocom2003, 2003*.
- [8] Szymon Jakubczak, Alex T. K. Lau, Lily Li, and Paul A. S. Ward. Feasibility-Based Rate-Control Fairness Algorithm for Wireless Mesh Networks. In *Institute of Computer Science, Warsaw University of Technology, Poland, School of Computer Science, Department of Electrical and Computer Engineering, University of Waterloo, Canada*.
- [9] Kamran Jamshaid, Lily Li, and Paul A.S. Ward. Gateway rate control of wireless mesh networks. In *First International Workshop on Wireless mesh: moving towards applications (WiMeshNets), 2006*.
- [10] J. Jun and M. L. Sichitiu. The Nominal Capacity of Wireless Mesh Networks. In *IEEE Wireless Communications, pp. 8-14, October 2003*.

- [11] J. Jun and M. L. Sichitiu. Fairness and QoS in Multihop Wireless Networks. In *Proceedings of IEEE Vehicular Technology Conference (VTC 2003)*, Orlando, FL, Oct. 6-9, 2003.
- [12] F. P. Kelly, A. Maulloo, and D. Tan. Rate Control in Communication Networks: Shadow Prices, Proportional Fairness and Stability. In *Journal of the Operational Research Society*, pages 237-252, 1998.
- [13] Ann Lee and Paul A. S. Ward. A Study of Routing Algorithm in Wireless Mesh Network. In *ATNAC'04*, Sydney, Australia, 2004.
- [14] R. Luo, D. Belis, R. M. Edwards, and G. A. Manson. A Simulation Design for Link Connection-oriented Wireless Mesh Networks. In *International Workshop on Mobile and Wireless Communications Network*, pp665-669, 2002, 2002.
- [15] M.A. Munawar and P.A.S. Ward. Are Two Interfaces Better Than One? In *Wireless And Mobile Computing, Networking And Communications, 2005.(WiMobapos,2005)*, *IEEE International Conference on Volume 2, Issue 22-24*, Aug. 2005.

- [16] Thyagarajan Nandagopal, Tae-Eun Kim, Xia Gao, and Vaduvur Bharghavan. Achieving mac level fairness in wireless packet networks. In *ACM MobiCom*, 2000.
- [17] B. Schrick and M. J. Riezenman. Wireless Broadband in a Box. In *IEEE Spectrum (June 2002)* 41-43., 2002.
- [18] G. Tan and J. Guttag. The 802.11MAC Protocol Leads to Inefficient Equilibria. In *Proceedings of Infocom2005*.
- [19] Andrew S. Tanenbaum. Computer Networks (Forth Edition). In *Vrije Universiteit*, Amsterdam, The Netherlands, 2003.
- [20] J. Tang, G. Xue, and W. Zhang. Maximum Throughput and Fair Bandwidth Allocation in Multi-Channel Wireless Mesh Networks. In *Proceedings of Infocom2006*.
- [21] L. Yang, W. K. G. Seah, and Q. Yin. Improving Fairness among TCP Flows crossing Wireless Ad Hoc and Wired Networks. In *Proceedings of MobiHoc2003*.