

Juraj Detvaj¹, Andrej Argay, Daniel Ruman²

Hollow wooden post and its interaction with metal structural members

Šuplji drveni stupovi i njihovo spajanje metalnim okovima

Professional paper · Stručni rad

Received – prispjelo: 14. 11. 2007.

Accepted – prihvaćeno: 28. 10. 2008.

UDK: 630*833

ABSTRACT • Wood is a competitive material to metal and concrete in the production of bearing members. These wooden bearing members are increasingly applied in building constructions. By reason of its natural character and properties, this material improves the architectural look of the structure, and hence it is suitable for use in different constructions.

Design feature – hollow wooden post is produced by gluing 12 lamellas with trapezoidal cross-section, furnished with slip feather and groove. Each lamella side is cut at an angle of 15° in order to achieve a closed circle in its cross-section. Hollow wooden post is especially made of spruce timber.

Wood–steel structural joints between individual structural members have a very important role in wooden structural constructions.

Key words: wooden post, bearing members, structural members, spruce timber

SAŽETAK • U proizvodnji nosivih elemenata u graditeljstvu drvo je konkurentan materijal metalu i betonu. Uporaba drvenih nosača je u porastu. Radi njihova prirodnog izgleda i svojstava drva kao materijala, drveni nosači oplemenjuju arhitektonske konstrukcije i zbog toga se sve češće upotrebljavaju u raznim nosivim konstrukcijama.

Šuplji drveni stup proizvodi se sljepljivanjem 12 lamela trapezoidnog presjeka, pri čemu je spajanje izvedeno uto-rom i perom. Svaka stranica lamele odrezana je pod kutom od 15°, a njihovim se spajanjem dobiva gotovo kružni poprečni presjek stupa. Takvi se stupovi izrađuju od smrekova drva.

U drvenim nosivim konstrukcijama važnu ulogu imaju metalni okovi koji služe za povezivanje drvenih nosivih elemenata.

Ključne riječi: drveni stupovi, nosivi elementi, metalni okovi, smrekovina

1 INTRODUCTION

1. UVOD

Due to their physical, mechanical and aesthetical properties, the use of hollow wooden posts has a relatively wide range of application in structural constructions. They can be installed properly indoors and outdoors. Indoors they bring a sense of convenience coupled with natural wooden look, wooden structure, co-

lor and unique scent. Outdoors, together with other wood based constructions, they provide a new look and meaning to a load carrying columnar wooden structural member (Detvaj *et al*, 1993; Šurikova *et al*, 1997).

Physical and mechanical properties of wood make it competitive to concrete and steel in constructions, as a fully natural alternative for load carrying members.

Authors are ¹assistant professor and ²assistants at the Faculty of Wood Science and Technology, Technical University of Zvolen, Slovak Republic. Autori su ¹docent i ²asistenti na Fakultetu znanosti o drvu i drvene tehnologije Tehničkog sveučilišta u Zvolenu, Republika Slovačka.



Figure 1 Indoor application of hollow wooden post
Slika 1. Primjena drvenih nosača na unutarnjim konstrukcijama



Figure 2 Outdoor application of hollow wooden post
Slika 2. Primjena drvenih nosača na vanjskim konstrukcijama

Possibilities of use are e.g.: streetlights, stairway support, terrace support, floor and balcony support, i.e. everywhere where the load carrying function is needed. Indoors it also has a secondary function of wiring integration (electrical, technical installations, air conditioning installations, etc.) through its hollow interior (Fig. 1 and Fig. 2).

2 PRODUCTION AND CARRYING CAPACITY OF STANDARD HOLLOW WOODEN POSTS

2. PROIZVODNJA I NOSIVOST STANDARDNIH DRVENIH NOSAČA

Hollow wooden posts are made as standard between 150 and 820 mm in diameter and 2.5, 3, 5 and 10 m in length. Production of nonstandard dimensions is limited by production technology.

By assembly of 12 lamellas glued together, vacuum is developed by working pressure so that negati-

ve pressure is developed in the post hollow interior and outer air pressure forces down the lamellas equally from all sides, Figure 3.

Several adhesives can be chosen for gluing. However the price for resin and phenol resin adhesives is higher, most producers use right these adhesives in technological operation of gluing. That is because resorcinol-based adhesives give the product the best stability and resistance of glued joint (Sedliačik and Sedliačik, 2000).

When applying glue, it is necessary to consider the final exposition of hollow wooden post, glue properties, wood surface quality, joint visibility, durability and joint strength, and resistance to environmental conditions where the final product will be exposed. In practice resorcinol-based and PVAC mounting adhesives are usually used regardless of the exposition of wooden post, as they give the post properties expected for outdoor use.



Figure 3 Body assembly and glue application
Slika 3. Postupak slaganja i lijepljenja nosača

Among others, the following adhesives are often used: melamine-formaldehyde, phenol-resorcinol, PF and melamine-urea formaldehyde adhesives. The characteristics of hollow wooden posts, which define the post in structural constructions, are the diameter, wall thickness and side dimension marked as a . Other attributes defining the wooden post and factors determining its carrying capability are the radius of gyration i , moment of inertia I , elastic modulus W , lamella area in cross-section A , as shown in Table 1 and Figure 4.

Diameter function in sectional characteristics is the side dimension of lamella used in sectional composition of wooden member, where lamellas area is the function of the post diameter and wall thickness. Increasing post diameter and retention of equivalent wall thickness can cause rising of sectional characteristics and also gross carrying capacity of wooden member.

Table 1 shows that the top carrying capacity is provided by the post 2.5 m long. By retaining the above said characteristics and changing the length, the load carrying capacity of the member decreases, because with increasing the slenderness ratio the carrying capacity of wooden member decreases.

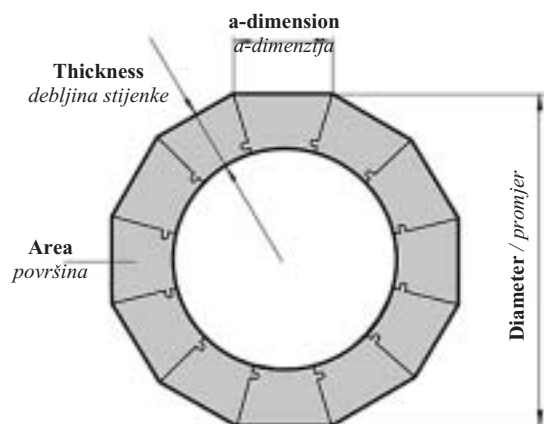

Figure 4 Post frontal cross-section and base determining parameters

Slika 4. Važni parametri poprečnog presjeka nosača

Planned strengths F_d are in Table 1 according to Swedish Eurocode, while the maximum allowable load of the member is $F_d = 75\%$ of the load value at which the failure occurs in wooden structural elements.

Hollow wooden posts were tested in our country and the test results were slightly different from the values and results shown in Table 1. Produced and thereafter tested posts had the following dimensions: diameter of 300 mm, lamella side dimension of 77 mm, wall thickness of 38.6 mm. Post length was 2 450 mm. The strength at which loss of the supporting member stability occurred was equal to 1 050 kN. The difference was probably caused by the used adhesive and applied production technology, which is in this specific case different from “Swedish” technology.

3 WOOD POST AND STEEL MEMBER JOINTS

3. SPAJANJE DRVENIH STUPOVA METALNIM OKOVOM

In wooden structural constructions the use and durability of wood-steel structural joints depends on joint design between individual structural members. The main ambition of design engineers is to develop the simplest post and steel member joints, using minimum

Table 1: Dimensions, sectional characteristics and carrying capacity of standard hollow wooden posts

Tablica 1. Dimenzije i karakteristike poprečnog presjeka te nosivost standardnih drvenih nosača

Code Kod	Diameter Promjer	Wall thickness Debljina stijenke	Side dimension Dimenzija stranica	Area Površina	Radius of gyration Radijus vrtnje	Moment of inertia Moment inercije	Elastic modulus Modul elastičnosti	Weight Masa	Maximum permissible load at effective length Najveće dopušteno opterećenje efektivne duljine			
									F_d $L=2.5m$	F_d $L=3m$	F_d $L=5m$	F_d $L=10m$
	mm	mm	mm	$mm^2 \cdot 10^3$	mm	$mm^4 \cdot 10^6$	$mm^3 \cdot 10^3$	kg/m	kN	kN	kN	kN
150032	150	32	40	12.1	44	23.23	309.7	5.77	163.7	122.2	46.5	0.0
195032	195	32	52	16.8	59	59.23	607.5	8.0	287.9	260.2	116.0	30.1
240032	240	32	64	21.4	75	121.31	1 011.0	10.2	392.5	372.9	227.7	61.2
300044	300	44	80	36.2	93	312.77	2 085.2	17.2	660.9	653.6	526.7	156.1
300064	300	64	80	48.6	87	372	2 477.8	23.1	890.7	870.2	654.7	186.2

variety of bond medium, fulfilling however the request on bond realization and functionality. The selection of bond medium is not only set by loading and carrying capacity, but also by aesthetic criteria, cost effectiveness and production process (Semanco, 2002).

Moreover it is necessary to consider the assembling method and architects' objectives.

If the wooden post is exposed outdoors, it is necessary to take into consideration that the contact between wood and other humid and hygroscopic material e.g. concrete and brick, can cause the capillary tran-

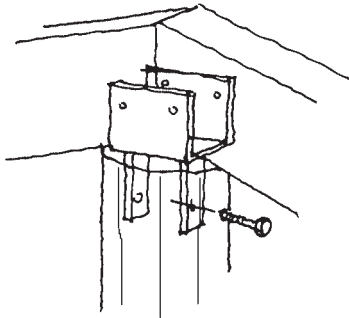

Figure 5 Head beam securing
Slika 5. Učvršćenje glavne grede

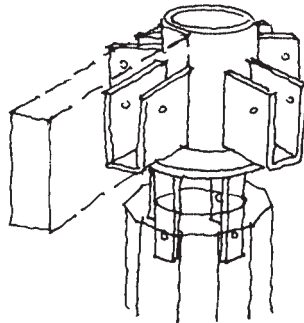

Figure 6 Bearer junction at the post
Slika 6. Način spajanja nosača i stupa

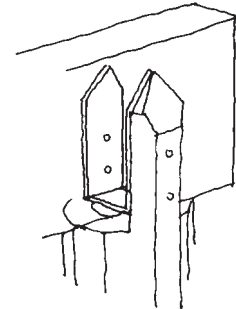

Figure 7 Bearer securing against pitching
Slika 7. Osiguranje nosača od iskliznuća

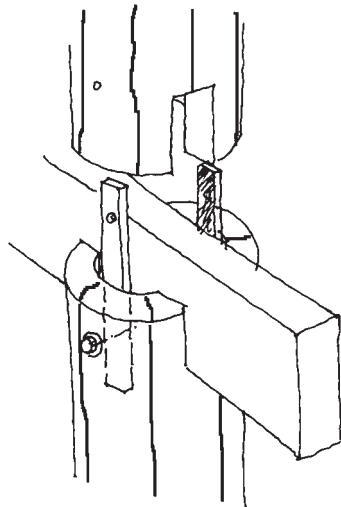

Figure 8 Bearer half embedded at post and post length adjustment
Slika 8. Križni sastav nosača i stupa s mogućnošću produljenja visine stupa

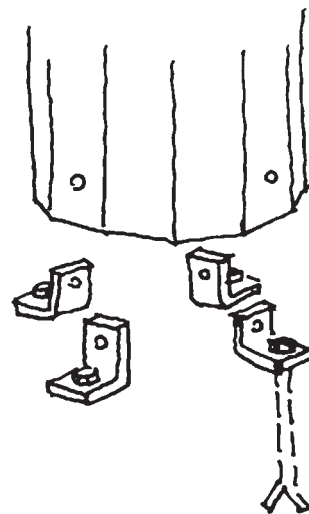

Figure 9 Fundamental hinge joint
Slika 9. Sidrenje stupa uz pomoć kutnika

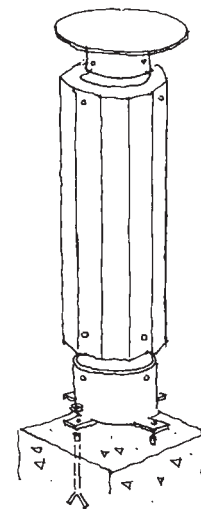

Figure 10 Fundamental hinge joint
Slika 10. Sidrenje stupa metalnom stopom

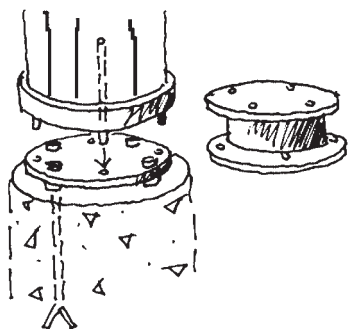

Figure 11 Fundamental rigid mounting
Slika 11. Ukrućenje osnove (temelja) stupa

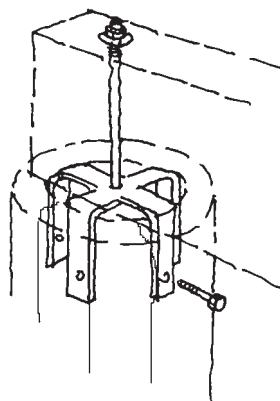

Figure 12 Bearer securing against pitching
Slika 12. Osiguranje nosača od iskliznuća

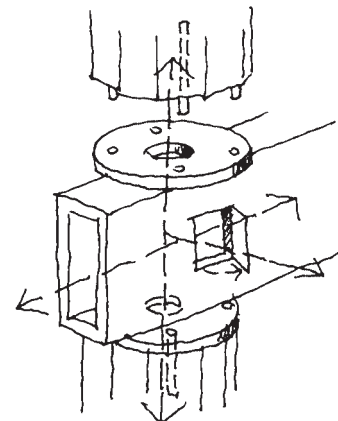

Figure 13 Post junction with steel elements
Slika 13. Način spajanja stupa čeličnim veznim elementima

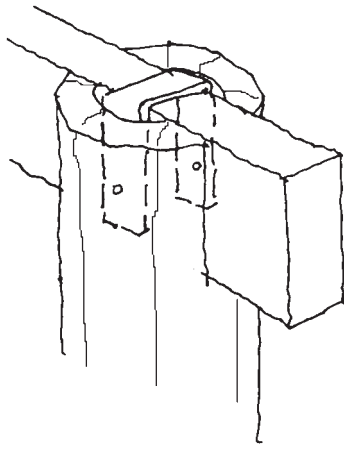

Figure 14 Entire embedding of bearer at post
Slika 14. Utorno upuštanje grede u stup

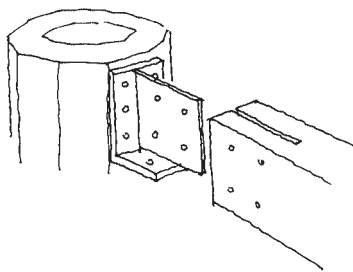

Figure 15 Anchoring a bridging joist on post
Slika 15. Povezivanje grede i stupa

sport of humidity. In this case the anchoring of the post with anchored footing and steel bolts is advisable (Hrčka, 1994; Gerner, 2003).

Possible interactions of steel with hollow wooden post in structural constructions are shown in Fig. 5 to Fig. 15.

Just in case of post anchoring in outdoor conditions, we worked out static expertise of steel footing and hollow wooden post in accordance with STN 73 1701, (1983). It deals with hinge joint, which represents the best wood characteristics as construction material. On the other hand it is difficult to achieve rigid mounting in structural construction (though the footings can partially receive the bending moment).

Various species of footing are designed for concrete techniques of post usage, be the post fixed, mostly in exteriors - Fig. 11, or in interiors, used for force transmission from roof structure or ceiling structure to foundations. Footings are additionally fastened by bolts or plugs, and their purpose is to transmit tensile forces. The pressure forces are transmitted through the contact of post and anchoring footing.

4 EXAMINATION OF PROPOSED FOOTING BOND

4. PRORAČUNAVANJE POSTOLJA NOSAČA

Examination of the proposed footing bond is made in accordance with STN 73 1701 (1983) and Komzala (1996).

- Three cases are considered in this examination:
- tensile force carrying capacity (according to the amount of bond media)
 - capacity of contact surface for sore pressure
 - side stress of footing

Selected statements: hollow wooden post, diameter of 300 mm, wall thickness of 64 mm, activity condition factors $\gamma_{R1} = 1, \gamma_{R2} = 1$.

- This case is frequent in open wood structures (summer houses, half span roofs for car ports), where the post serves for bearing a roof structure. The proposal considers 4 steel plugs with the diameter of 16 mm, used for anchoring the post with footing. Selected statements: plugs diameter $d = 16$ mm, wall thickness $t_1 = 64$ mm, amount of plugs = 4 pcs, activity condition factors $\gamma_{R1} = 1, \gamma_{R2} = 1$.

For single-shear plug bonds the following applies:

$$T_{1d} = 5 \cdot t_1 \cdot d \cdot k = 5120N \cdot \gamma_{R1} \cdot \gamma_{R2} = 5120N \quad (1)$$

$$T_{2d} = 22 \cdot d^2 \cdot \sqrt{k} = 5632N \cdot \gamma_{R1} \cdot \gamma_{R2} = 5632N \quad (2)$$

Maximum tensile force on the post at the footing connection point:

$$n = \frac{N_d}{T_{1d}} \Rightarrow N_d = T_{1d} \cdot n = 5120 \cdot 4 = 20480N = 20,48kN$$

If the maximum allowable load on the post is required at the footing point, then it would be necessary to provide more bond media, increase the lamella thickness, or increase the diameter of bonding media.

By this type of stress should be considered capacity in sore pressure of steel plug at footings band steel and dimension of the anchor steel in single footing.

- Capacity of contact surface for sore pressure:

$$\text{Contact surface of post face } A = 48,6 \cdot 10^3 \text{ mm}^2$$

Wood computing strength of pressure parallel to grain $R_{CDII} = 12$ MPa

Expertise for sore pressure of post face to steel footing:

$$\frac{F_{MAX}}{A} \geq R_{CDII} \cdot \gamma_{R1} \cdot \gamma_{R2} \Rightarrow F_{MAX} = \quad (3)$$

$$= A \cdot R_{CDII} \cdot \gamma_{R1} \cdot \gamma_{R2} = 583,2 \text{ kN}$$

Where F_{max} is maximum force of sore pressure that should not be exceeded.

- Side stress of footing:

Wood computing strength of pressure across the fibers in bearer pile $R_{CD\perp} = 2,4$ MPa

Post side contact surface on one steel band $A_K = 7500 \text{ mm}^2$

$$\frac{N_{MAX}}{A_K} \geq R_{CD\perp} \cdot \gamma_{R1} \cdot \gamma_{R2} \Rightarrow N_{MAX} = \quad (4)$$

$$= A_K \cdot R_{CD\perp} \cdot \gamma_{R1} \cdot \gamma_{R2} = 18kN$$

- Where N_{max} is maximum horizontal force of sore pressure of wood side surface, which should not be exceeded.

By this type of stress it is necessary to consider the anchor steel weld joint with footings steel sheet, Fig. 16.

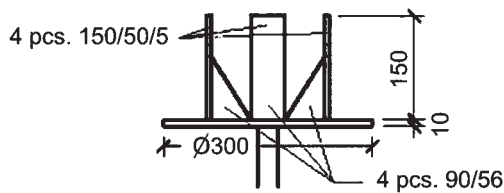

Figure 16 Footing steel sheet
Slika 16. Čelični okvir za temeljenje nosača

Equal force that must be transmitted through steel band 150/50/5 mm is obtained by bending moment and that is why it is recommended to stiffen it with steel folding and to weld it together on four sides with fillet weld of 5 mm as shown in Figure 16.

4 CONCLUSION

4. ZAKLJUČAK

Use and dimensioning of wooden columnar member as well as steel anchoring material depend on specific conditions, exposure of the member to static magnetic fields, and specific types and size of forces and stress on wooden structural member. For these and other conditions it is necessary to prepare particular reports, e.g. investigation of buckling stress, investigation of tensile stress in real situation for exploring the possibility of carving, and even the investigation of cross wind resistance, i.e. all construction factors, based on which the main role of the bearing member will be defined.

5 REFERENCES

5. LITERATURA

1. Detvaj, J.; Hrčka, I.; Dudas, J.; Šúriková, A. 1993: Návrh stĺpového konštrukčného prvku na výrobu drevostavieb.

- Proceedings of scientific papers, DF TU Zvolen, p. 105-115, ISBN 80-05-01107-5
2. Hrčka, I.; Oswald, A.; Dzurenda, L.; Makovíny, I. 1994: Projektovanie drevených stavieb. Technical University in Zvolen, pp. 342, ISBN 80-228-0332-4
3. Gerner, M. 2003: Tesařské spoje, pp. 220, ISBN 80-247-0076-X
4. Komzala, M. 1996: Návrh technológie výroby dutých drevených prvkov a overenie ich mechanických vlastností. Technical University in Zvolen, diploma work, pp. 44.
5. Sedliačik, J.; Sedliačik, M. 2000: Lepenie dreva. Technical University in Zvolen, pp. 236, ISBN 80-228-0968-3
6. Semanco, S. 2002: Zlepšovanie mechanických a úžitkových vlastností dutých drevených stĺpov. Technical University in Zvolen, dissertation, pp. 74.
7. Šúriková, A.; Detvaj, J.; Dudasová, V. 1997: Dutú drevené stĺpy z hľadiska požiarnej odolnosti. AFX, Technical University in Zvolen, p. 77-85, ISBN 80-228-0687-0
8. *** 1983: STN 73 1701 – Navrhovanie drevených stavebných konštrukcií, ÚNM, Praha.
9. *** COMWOOD – propagand materials of Martinsons

Corresponding address:

Assistant Professor JURAJ DETVAJ, PhD

Faculty of Wood Sciences and Technology
Technical University in Zvolen
Masarykova 24
960 53 Zvolen
Slovakia
e-mail: detvaj@vsld.tuzvo.sk