

NOvA FAR DETECTOR MODULE FIBER QA TEST ANALYSES

Amanda K. Bowers and Dr. Gregory Pawloski
School of Physics and Astronomy, University of Minnesota, Minneapolis, MN.

Background and Introduction

- Neutrinos are neutral leptons that interact via the electroweak force.
- Neutrinos come in three flavor eigenstates: ν_e, ν_μ, ν_τ . These states are linear combinations of mass eigenstates, denoted ν_1, ν_2, ν_3 . Observations of oscillations between flavor states have been made.
- Mixing angles are the measurable parameters that govern how neutrinos oscillate. They are provided here in the Pontecorvo–Maki–Nakagawa–Sakata (PMNS) matrix:

$$U = \begin{bmatrix} 1 & 0 & 0 \\ 0 & \cos \theta_{23} & \sin \theta_{23} \\ 0 & -\sin \theta_{23} & \cos \theta_{23} \end{bmatrix} \begin{bmatrix} \cos \theta_{13} & 0 & \sin \theta_{13} e^{-i\delta} \\ 0 & 1 & 0 \\ \sin \theta_{13} e^{i\delta} & 0 & \cos \theta_{13} \end{bmatrix} \begin{bmatrix} \cos \theta_{12} & \sin \theta_{12} & 0 \\ -\sin \theta_{12} & \cos \theta_{12} & 0 \\ 0 & 0 & 1 \end{bmatrix}$$

- NOvA (NuMI¹ Off-Axis ν_e Appearance) is a neutrino detection experiment with two detectors, both located 14 mrad off axis with respect to the NuMI beam:
 - The near detector is located at Fermi National Accelerator Laboratory (FNAL), the origin of the ν_μ beam.
 - The far detector is located 810 km away from FNAL.
- NOvA's main physics goals are as follows:
 - Determine the mass hierarchy
 - Determine whether or not neutrinos exhibit CP violation
 - CP violation yields a non-zero value of δ
 - Measure θ_{13}
 - Refine precision measurements of θ_{23}

¹NuMI- Neutrinos at the Main Injector. The Main injector is housed at FNAL and produces the ν_μ beam using a carbon target.



Far detector

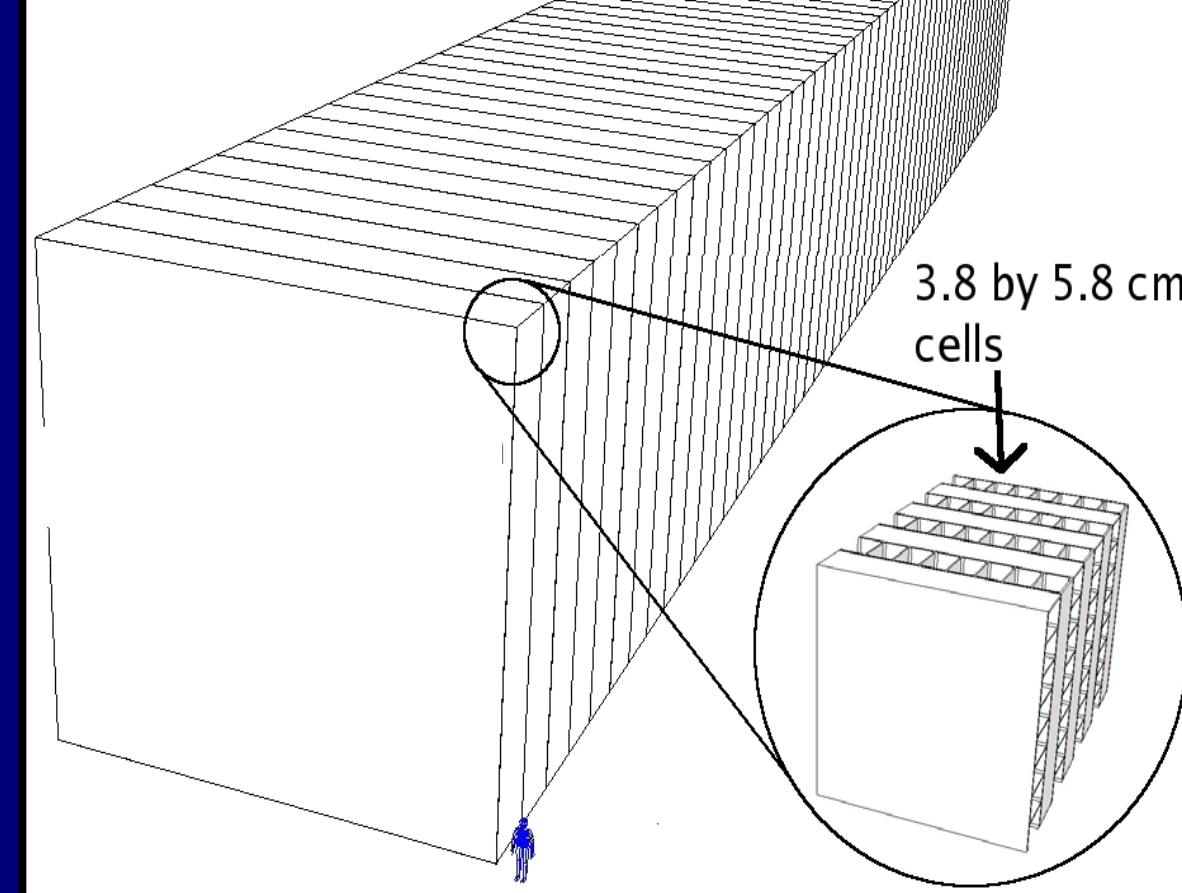

Figure 1. Diagram of far detector. Adjacent planes of modules are oriented perpendicularly to give x, y resolution, as depicted in diagram inset.

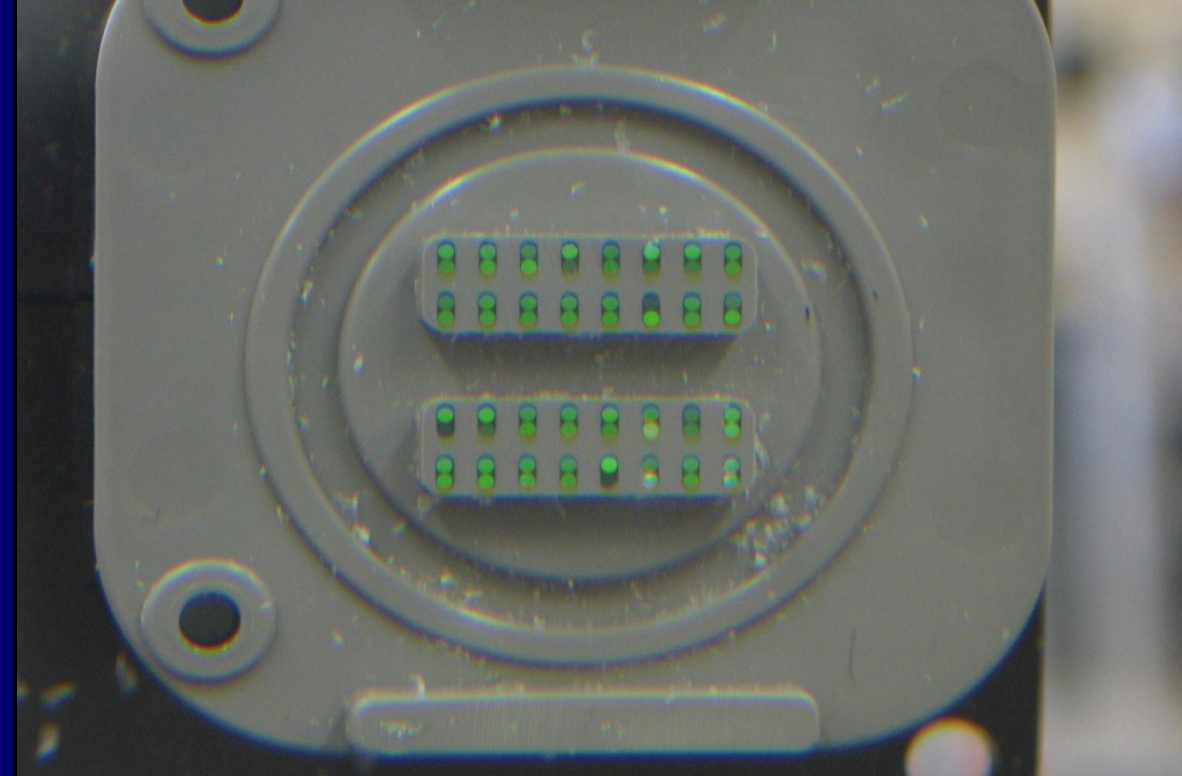

Figure 2. Photograph of optical connector (grey) with cut fiber ends. Each cell has a single loop of fiber running down the length of a cell with both ends terminating in the optical connector. Bright fibers shown here are damaged and would fail the visual test.

Module Construction, Stringing and Test Performance

- Far detector comprises ~11,000 individual modules made of PVC and filled with liquid scintillator.
- Light is emitted by scintillating liquid excited by charged particles travelling through it.
- Wavelength shifting fibers transmit light to the Avalanche Photodiodes (APDs).
- Fiber QA tests are in place to check for damaged fibers:
 - The stringing fiber test (SFT) looks for damage during stringing using a blue LED to measure relative intensity of lost transmitted light.
 - The closed fiber test (CFT) uses a red LED to measure transmitted light through the module.
 - The visual test is a qualitative check for low-transmitting fibers.
 - The visual card test is a qualitative check for high-reflecting fibers.

Figure 5. A photograph of fiber stringing at the NOvA module factory, located in Minneapolis, MN. A pulley is used to pull loops of fiber down individual cells. Fibers are shipped to Minnesota on spools (left).



Test Results and Analysis

- The effects of tension during stringing were analyzed to search for a potential source of damage:

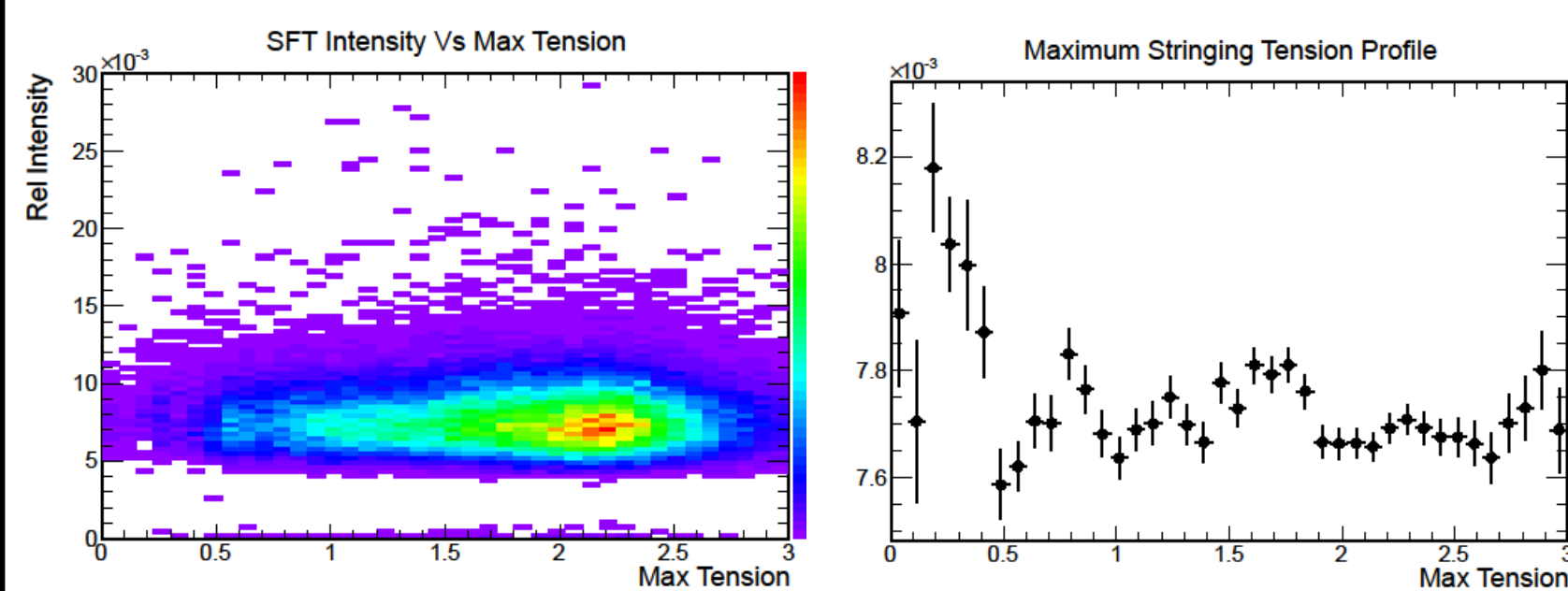

Figure 3. Two dimensional histogram and profile of ratio of transmitted light and maximum stringing tension are shown. The profile shows the mean of each x (x=bin size) Newton bin with error bars indicating a 1 sigma deviation from the mean.

- Relative light intensity from the SFT is a ratio of light intensities calculated by dividing the final measurement (32 m of fiber) by the initial measurement (0 m of fiber). Measurements are taken continuously.
- Over-tension alarms are triggered when a maximum tension greater than 3 Newtons is reached. Those cells are restrung and not included here.
- These plots indicate that high tension, under the alarm value, does not damage fiber.

- Cross-test analysis between the SFT and the CFT was performed to search for correlations between the tests:

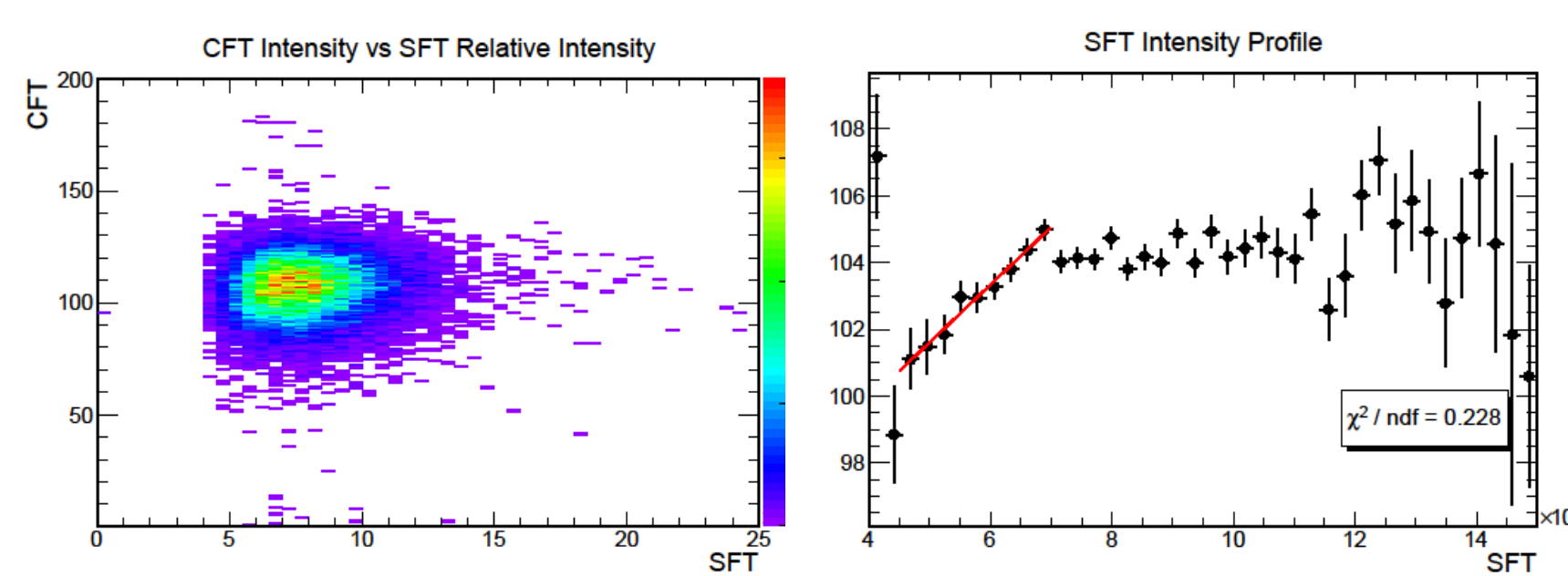

Figure 4. Two dimensional histogram and profile of ratio of transmitted light obtained by SFT and normalized light intensities from CFT are shown. The profile shows the mean of each x (x=bin size) bin with error bars indicating a 1 sigma deviation from the mean. A linear regression is shown from 0.005 to 0.007 on the profile. The χ^2 to number of degrees of freedom ratio for the fit is 0.228.

- A slight positive correlation is observed between the two tests, as indicated by a positive χ^2 statistic.
- The results are as expected because they are both measuring the same thing, relative transmitted light loss.
- Results suggest that the wavelength of light used to perform the test (blue LED used in the SFT vs. red LED used in CFT) is independent of the test's outcome.

- Once the CFT and SFT were correlated, further analysis was performed on CFT to verify that tension had no effect on light attenuation:

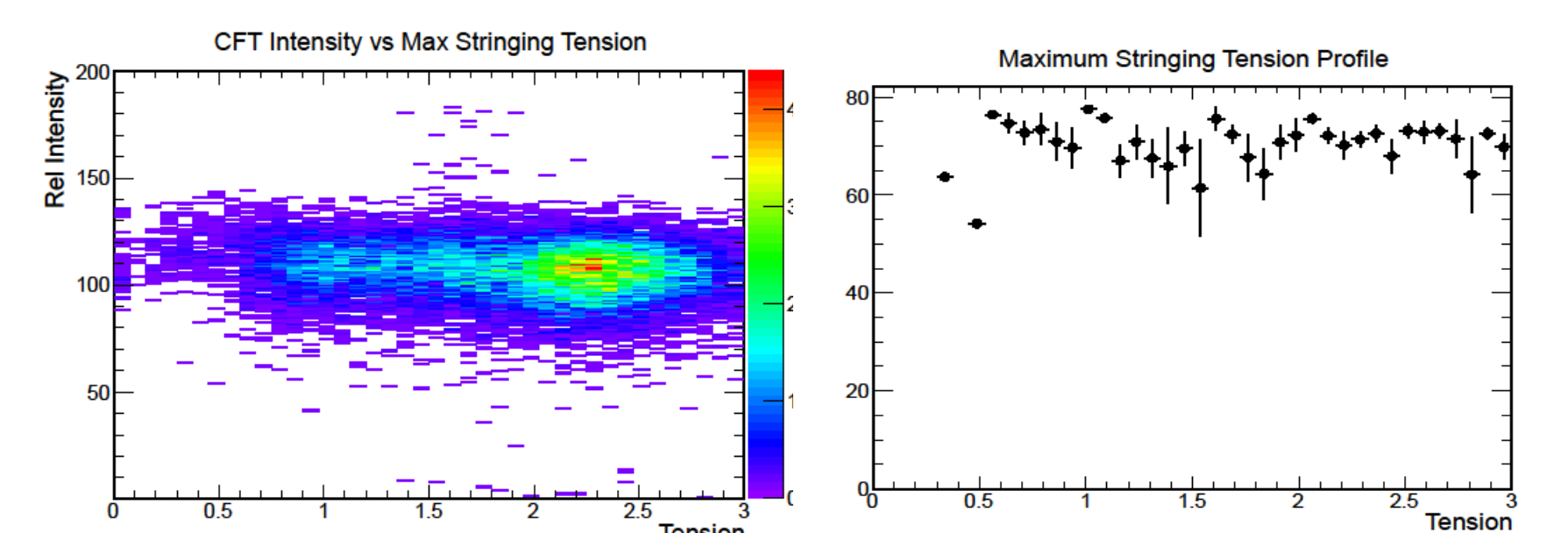

Figure 5. Two dimensional histogram and profile of relative transmitted light and maximum stringing tension as obtained by the CFT are shown. The profile shows the mean of each x (x=bin size) bin with error bars indicating a 1 sigma deviation from the mean.

- Histogram has slight tail with negative slope but otherwise looks flat.
- Indicative that stringing at high tensions under 3 N does not do significant damage to fibers.
- Similarities to fig. 3 suffice as further evidence to suggest tests are correlated.

Test Results and Analysis cont.

- Analyses were performed on the visual and visual card tests to look for correlations between the two tests and within each test between cells:

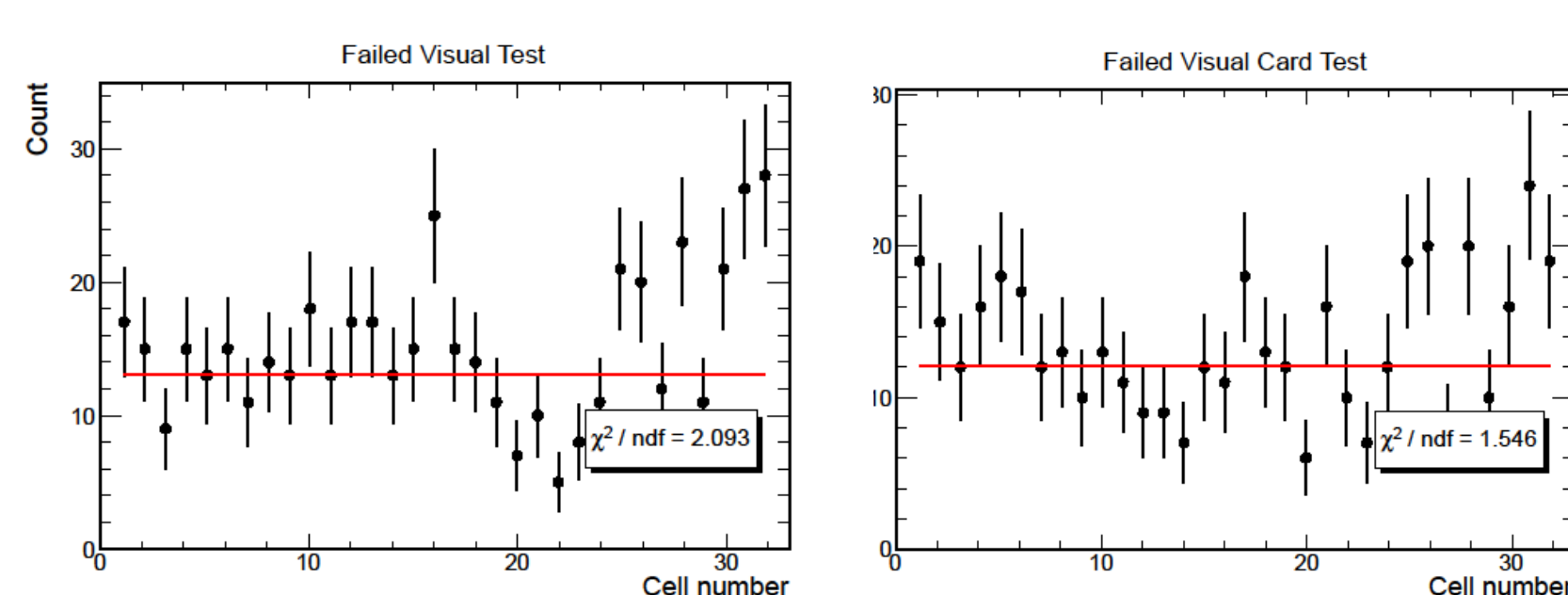

Figure 6. One dimensional histograms of visual fiber test failures (left) and visual card test failures (right) as functions of cell number. Fiber entries of the two adjacent plots are not mutually exclusive and therefore, there is likely a high overlap in fiber failures for both tests. Regressions are fit to both plots yielding a χ^2 to number of degrees of freedom ratio of 2.093 for the visual test and of 1.546 for the visual card test.

- Uniform distributions are observed for both visual and visual card tests as determined by the relatively low χ^2 statistics.
- Flat distributions indicate that there is no correlation between failed fiber frequency and cell number, as expected for adequately functioning tests.
- Further analysis of the mutually failing fibers is needed to determine cross-test correlation.



Figure 6. A photograph of Ash River, MN, the site of the NOvA far detector.

Future Work

- Analyses on these as well as other tests continues.
- The camera test will be implemented in the near future acting as a quantitative supplement to the visual and visual card tests.
- The module factory is currently at full production and the first module was installed at Ash River on August 1, 2012. The detector is expected to begin taking data in 2013 and the first run will last six years.

Acknowledgments

The authors would like to extend their gratitude to all faculty members, post-docs and graduate students working on NOvA at the University of Minnesota, as well as the factory workers. We also thank the National Science Foundation for funding this research.

