

University of Louisville

ThinkIR: The University of Louisville's Institutional Repository

Electronic Theses and Dissertations

5-2011

An immediate survival focus : linking substance abuse, fight, flight, and prosocial behavior.

George B. Richardson
University of Louisville

Follow this and additional works at: <https://ir.library.louisville.edu/etd>

Recommended Citation

Richardson, George B., "An immediate survival focus : linking substance abuse, fight, flight, and prosocial behavior." (2011). *Electronic Theses and Dissertations*. Paper 1202.
<https://doi.org/10.18297/etd/1202>

This Doctoral Dissertation is brought to you for free and open access by ThinkIR: The University of Louisville's Institutional Repository. It has been accepted for inclusion in Electronic Theses and Dissertations by an authorized administrator of ThinkIR: The University of Louisville's Institutional Repository. This title appears here courtesy of the author, who has retained all other copyrights. For more information, please contact thinkir@louisville.edu.

AN IMMEDIATE SURVIVAL FOCUS:
LINKING SUBSTANCE ABUSE, FIGHT,
FLIGHT, AND PROSOCIAL BEHAVIOR

By

George B. Richardson
B.A., University of Louisville, 2006
M.Ed., University of Louisville, 2008

A Dissertation
Submitted to the Faculty of the
Graduate School of the University of Louisville
in Partial Fulfillment of the Requirements
for the Degree of

Doctor of Philosophy

Department of Education and
Counseling Psychology
University of Louisville
Louisville, KY
May 2011

Copyright 2011 by George B. Richardson

All Rights Reserved

AN IMMEDIATE SURVIVAL FOCUS:
LINKING SUBSTANCE ABUSE, FIGHT,
FLIGHT, AND PROSOCIAL BEHAVIOR

By

George B. Richardson
B.A., University of Louisville, 2006
M.Ed., University of Louisville, 2008

A Dissertation Approved on

April 6, 2011

by the following Dissertation Committee:

Dissertation Director (Patrick Hardesty)

Jill L. Adelson

Nancy J. Cunningham

Marcus Munafo

Jeffry C. Valentine

DEDICATION

This dissertation is dedicated to my wife, Whitney, who helped me become a slow
life history strategist.

ACKNOWLEDGEMENTS

I would like to thank my wife, Whitney, who by virtue of her kindness, fell victim to learning nearly the entire content of this dissertation. Whitney, what would I be doing right now if we hadn't met? Thank you for your patience. I would like to express great thanks to my dissertation director, Dr. Patrick Hardesty. I needed another armchair philosopher to achieve the intellectual growth this dissertation represents. Thank you, Dr. Hardesty for all of your time and thoughts. Your encyclopedic mind was invaluable, and continues to point me in new directions. I must acknowledge that Dr. Nancy Cunningham inspired me to be a counselor and then both a researcher and educator. Dr. Cunningham, I was sure I wanted to be a counselor when I met you in class, and your support and encouragement led me into the doctoral program. Is three years a long time? No, you were right; it flew by. This paper wouldn't have been possible without the generous statistical assistance provided by Dr. Jill Adelson. Dr. Adelson, thank you for the endless Q&A. I also thank my other committee members, Dr. Jeffrey Valentine and Dr. Marcus Munafó, for their valuable feedback and assistance. In addition, thank you Dr. Aurelio José Figueredo for your helpful comments. Finally, I give many thanks to my family, who have always been there and provided me with love. This dissertation has been a great pleasure for me. Thanks to everyone who made it possible.

ABSTRACT

AN IMMEDIATE SURVIVAL FOCUS: LINKING SUBSTANCE ABUSE, FIGHT, FLIGHT, AND PROSOCIAL BEHAVIOR

George B. Richardson

May 13, 2011

In the United States substance abuse takes a toll that is costly in both economic and human terms. In 2005 we paid 467.7 billion dollars to address the consequences of substance abuse, and each year we have lost an estimated 537,000 of our fellows to substance abuse related causes. It is important that we identify and intervene upon the mechanisms translating risk factors for substance abuse into the related behaviors.

This study synthesized life history theory and dual process models of cognition to produce an adaptive and cognitive framework for explaining substance abuse. An immediate survival focus was proposed as a construct representing reliance on implicit cognitive processing for the purpose of quick evaluation and short-term strategy use in dangerous or unpredictable environments. This immediate survival focus was suggested as contributing to false positives in the detection of resources and threats critical to survival (i.e., irrational beliefs), and thus vulnerability to substance abuse.

This study tested for an immediate survival focus and produced results consistent with the existence of the construct. A factor theorized to represent the ISF was extracted from constructs known to rely on implicit cognitive processing, and this factor was positively associated with both substance abuse and neighborhood danger, as predicted

by the adaptive and cognitive framework advanced. In addition, this construct was negatively associated with prosocial behavior, which is known to operate to the relative exclusion of implicit cognitive processes. The strength of the relationships between the ISF and the study's constructs was substantial for both sexes, though its relative importance to substance abuse was less for females. For the sample as a whole, the ISF accounted for 38% of the variance in substance abuse, therefore representing an important construct in efforts to learn about, treat, and prevent substance abuse.

TABLE OF CONTENTS

	PAGE
ACKNOWLEDGEMENTS.....	iv
ABSTRACT.....	v
LIST OF TABLES.....	ix
CHAPTER	
I. INTRODUCTION.....	1
Statement of the Problem.....	8
Purpose of the Study.....	9
Limitations.....	10
Significance of the Study.....	13
Research Questions.....	15
II. REVIEW OF THE LITERATURE.....	17
Scope of the Literature Review.....	17
Substance Abuse Prevalence.....	17
Theoretical Conceptualization.....	19
IV. METHODOLOGY.....	40
Research Questions.....	40
Sample and Procedures.....	40
Instruments.....	44
Analysis.....	47
V. RESULTS.....	50

Confirmatory Factor Analysis.....	50
Structural Equation Modeling.....	52
VI. DISCUSSION.....	66
Theoretical Contributions of the ISF.....	66
Results and Future Directions.....	73
REFERENCES.....	75
APPENDICES.....	84
CURRICULUM VITAE.....	88

LIST OF TABLES

TABLE	PAGE
1. Sample Demographic Information.....	43
2. Scale Items by Factor.....	46
3. Analysis of Subscales.....	47
4. Measurement Model and Modifications.....	52
5. Full Structural Model and Modifications.....	53
6. Unstandardized and Standardized Effects.....	55
7. Alternative Structural Models.....	60
8. Structural Models for Males and Females.....	62
9. Multi-Group Tests of Invariance for the Structural Portion of the Final Model.....	63

CHAPTER I

Introduction

“In the absence of forethought, there is just one way to skin a cat.”

Context

Recent research has applied cognitive science to the understanding of substance abuse (for a review see Munafo & Albery, 2006). One result of this application is that dual process models, where explicit (i.e., deliberative) cognitive processes are modeled as relatively distinct from implicit (i.e., automatic) cognitive processes, have been used to explain and predict substance abuse behaviors (e.g., Munafo & Albery, 2006; Redish, Jensen, & Johnson, 2008; Stacy & Wiers, 2006). Recent research has also applied evolutionary life history theory to the understanding of behaviors often conceived of as prosocial (i.e., cooperative) or antisocial (i.e., uncooperative; e.g., Figueredo et al., 2005; Ellis, Figueredo, Brumbach, Schlomer, 2009; Rushton, Bons, & Hur, 2008). In this study these two theoretical perspectives are synthesized to produce an adaptive and cognitive framework for explaining substance abuse. The purpose of this study is to test for an immediate survival focus, hypothesized to be supported by implicit cognitive processes, and to operate to the relative exclusion of explicit cognitive processes. Specifically the study tests the possibility that this immediate survival focus links neighborhood danger, substance abuse, trait aggression, trait submission, and prosocial behavior.

The following sections provide the reader with the evolutionary context necessary for understanding the operation of the cognitive processes mentioned above. While for

some purposes it may be sufficient to note that there are two relatively distinct types of cognitive processes that support different sorts of behavior, an evolutionary perspective provides the ground for making predictions about how implicit and explicit processes interact with the environment to produce these behaviors. Contextualizing dual processes within an evolutionary framework provides us with ideas about how these processes came about, and with ideas about how these processes might function today.

This contextualization is begun with a brief discussion of the evolution of cognitive control of the emotions. Following this life history theory is introduced as a lens for understanding the cooperative, planful use of resources for long-term survival and reproduction, along with the antisocial use of resources for short-term survival. Dual process models of cognition are then introduced as a perspective for understanding both the long-term, planful, and cooperative use of resources, and also the short-term antisocial use of resources. Finally, a framework for understanding the evolved and adaptive nature of explicit cognitive processes, best suited to cooperative and planful long-term survival, and implicit cognitive processes, best suited to uncooperative short-term survival and neural resource conservation, is summarized.

The Evolution of Cognitive Control of the Emotions. The evolution of the current human experience of anger and anxiety forever changed the manner of survival and reproduction in which our ancestors engaged (Berridge, 2003). Today the human experience of these emotions is one characterized by cortical control (Berridge, 2003), with anger being processed by the left prefrontal cortex, and anxiety by the right prefrontal cortex (Davidson, 2004). Instead of simply aggressing and retreating to avoid threats and meet their needs, humans became the possessors of substantial flexibility in

response to their environments (van Honk & Schutter, 2007). According to van Honk and Schutter (2007), cognitive control over the emotions may have given humans the ability to carry out plans. This capacity for planning and flexibility may have covaried with an increasing human adeptness for cooperation (i.e., group acquisition and control of resources). Indeed, facets of conscientiousness characterized by cognitive control have been found to relate positively to work dedication and healthy behaviors, while those characterized by low deliberation, or lack of cognitive control, have been observed to be positively related to risky and antisocial behaviors (Roberts, Chernyshenko, Stark, & Goldberg, 2005; Whiteside & Lynam, 2001). In a related vein, Geary and Flinn (2001) made the case that over the last 4,000,000 years male coalition formation has been associated with the reduction in sexual dimorphism and dramatically increased brain size found in *H. Sapiens*, contrasted against *A. Afarensis*. The association between brain size, particularly the prefrontal regions, cortical or executive control, and cooperation among humans is notable.

Life History Theory and Human Resource Use. Evolutionary biologists originally studied the r/K continuum of reproductive behavior with a focus on between-species differences, with r-selected species investing highly in reproductive effort (i.e., rabbits and fish), and K-selected species investing more in somatic and parental effort (i.e., elephants and humans; Figueredo et al., 2006). In other words, r-selected species have been observed to invest more resources in the short-term survival of many offspring, because many may die, as is the case for rabbits and fish. K-selected species have been observed to invest more resources in the long-term survival of few offspring, as relatively

few will die, and because investment increases offspring competitiveness (Geary & Flinn, 2001).

In addition to observing between-species variation in life history, researchers have found support for within-species variation in life history strategy, and Rushton (1985) found support for the proposition that such variation exists in humans (see also Figueredo et al., 2005). The r/K continuum of reproductive behavior has very recently been referred to as the slow-fast life history continuum in literature related to human behavior, with slow life histories being associated with behaviors such as careful consideration of risks, long-term thinking, and cooperation, and with fast life histories being associated with behaviors such as risk-taking, short-term thinking, and anti-social behaviors (Figueredo et al., 2005; Ellis, Figueredo, Brumbach, Schlomer, 2009).

Life history theory provides a lens for understanding the cooperative and planful use of resources for long-term survival and reproduction, and the uncooperative and more impulsive use of resources for short-term survival and reproduction. The adaptive value of each life history strategy is partly a function of context. Evolutionary life history theorists, Kruger, Reischl, and Zimmerman (2008), indicated that r-selected species (i.e., those with fast life histories) have been associated with unpredictable environments, while K-selected species (i.e., those with slow life histories) have been associated with predictable environments. Humans may have some ability to use facultative strategies adapted to either context (e.g., time perspective; see Kruger et al., 2008). Human cognition may be sensitive to the predictability of an environment, activating processes and behaviors consistent with slow life history strategies in predictable, safe, or stable environments, or processes and behaviors consistent with fast life histories in

unpredictable, unsafe, and unstable environments (Ellis et al., 2009). Indeed, many of the behaviors associated with fast life histories and unpredictable environments are those requiring lesser deliberation, while many of the behaviors associated with slow life histories and predictable environments are those requiring greater deliberation (Figueredo et al., 2006). Consistent with these notions, Quinlan (2007) found an association between pathogen load and parental investment, and Chisholm (1993) reviewed associations between uncertain environments (e.g., characterized by family conflict) and both earlier ages of reproduction and higher reproductive rates. In addition, Ellis et al. (2009) found associations between environmental harshness, environmental unpredictability, and life history strategy, along with an association between the two environmental constructs and social deviance.

Dual Process Models of Cognition and Human Resource Use. Forethought, or long-term planning, can be observed in the achievements we admire, including the skyscrapers that form our cities' skylines, the medical technologies that save the lives of our loved ones, and the large populations of humans sustained by modern agriculture. Of course forethought is of great use only when a relatively large quantity of resources can be acquired and used according to a long-term plan. Putting theory into practice requires agreement among people to share resources toward an end, and we have seen people achieve great things when they cooperate to realize a common goal. Arguably many of the values or norms found in modern industrialized societies (e.g., socially imposed monogamy; Geary & Flinn, 2001; see also Batson, 1995) reflect some consensus related to the utility of long-term and planned cooperation (e.g., marriage). While it may be a

relatively simple task to help someone create a plan, living daily in a manner consistent with a long-term plan is much more complex.

The ability to share resources to achieve valuable outcomes is comprised of many micro abilities. These include – but are not limited to – social skills underpinning social competence, such as communication skills (e.g., assertiveness) and emotional control (e.g., affect regulation or anger management; Rose-Krasnor, 1997; Yucel, Lubman, Solowij, & Brewer, 2007). At another level of analysis (i.e., cognition) the mechanisms supporting such abilities might be examined, including those related to implicit processes, explicit processes, working memory, expectancy, and reward (see Cunningham, 2004, 2007; Lieberman, 2007; Margaron, 2004; Stacy & Wiers, 2006; Volkow et al., 2007). At the level of personality, Rushton et al. (2008) have suggested that the general factor of personality simply represents social adeptness, or social facility. This factor was found to be around 50% heritable, and here we are reminded that one's social facility is informed by the rules for building a human, which are embedded in genes (Rushton et al., 2008).

As mentioned, one level at which to analyze the ability to carry out a long-term cooperative plan is the level of cognition. At this level the factors which represent predispositions for behavior are translated into outward behaviors. This is the level of analysis in which reductionist science and holistic human experience most closely embrace. At the level of cognition one's genetics and environment are translated into expectancies. These expectancies represent the transfer of an organism's experiences into biological tissue, to prepare the organism for future encounters with similar circumstances (Goldman, Darkes, Reich, & Brandon, 2006). These expectancies contain

the value of rewards, along with the probability of achieving them through particular behavioral strategies in future contexts (Wigfield & Eccles, 2002; Higgins & Spiegel, 2004; Redish et al., 2008). Goldman et al. (2006) suggested that expectancy may even be the “functional outcome of epigenesis” (pg. 149).

Expectancies are sometimes formulated quickly, with little deliberation and even without conscious awareness, but are also formulated slowly, with greater deliberation and more penetrating insight (see Redish et al., 2008). Expectancies are translated into behaviors both automatically (i.e., implicitly) and deliberately (i.e., explicitly; Munafo & Albery, 2006; Redish et al., 2008). When automatic, human cognition seems to respond better to contexts requiring quick response to threats or available resources. When deliberate, our cognition appears to respond better to contexts requiring planful and cooperative response to such stimuli.

The Evolved and Adaptive Nature of Dual Cognitive Processes. An evolutionary view of dual-process models of cognition has been referenced above (see Gilbert, 1998). Natural selection may have selected for the mechanisms supporting implicit cognitive processes as a function of their contribution to fitness in particular threatening or unpredictable situations, as a function of their contribution to fitness (i.e., survival and reproduction) in generally unpredictable or dangerous contexts (e.g., geographical locales), and as a function of their contribution to neural resource conservation in familiar circumstances. Conversely, the mechanisms supporting explicit processes may have been selected for as a function of their contribution to complex problem solving where safety and time were available, and in generally safe and predictable contexts where social competition had become great. In other words,

variation in the automaticity or deliberativeness of cognition may have been retained by selection because human environments have been variable in their predictability and safety. Thus individuals characterized by unpredictable environments and fast life histories may rely more heavily on implicit cognitive processes, while those who are characterized by predictable environments and slow life histories may rely more heavily on explicit processes.

Statement of the Problem

Adaptation to unpredictable and unsafe environments may be associated with a greater reliance on implicit, or automatic cognitive processing. Such a reliance on implicit processing may be maladaptive in predictable and highly socio-competitive contexts (e.g., modern industrialized societies). Substance abuse, a significant modern societal and individual problem, may be associated with a lack of planning and a reliance on implicit cognitive processes (Allen, Moeller, Rhoades, & Cherek, 1997). This reliance on implicit processes may be related to frequent false positives in the detection of resources and threats critical to survival and reproduction. Such misdetection may have been selected for in ancestral human environments (i.e., environment of evolutionary adaptedness; Mealey, 2000, Chapter 1) that were unpredictable and dangerous, where the cost of a failure to detect limited resources or imminent threats would have outweighed the cost of false positives (i.e., smoke detector effect; Nesse & Williams, 1996; and see Gilbert, 1998).

Researchers in the area of addiction science have identified various factors that predict level of substance abuse. These factors include heritable (e.g., sensation seeking),

niche (e.g., delinquent peer group), and environmental risk factors (e.g., family conflict; Kendler, Prescott, Myers, & Neale, 2003; Kilpatrick et al., 2000; Nation & Heflinger, 2006; Nesse, 1994; Stoel, Geus, & Boomsa, 2006; Whiteside & Lynam, 2001).

Additionally, researchers in the area of cognition and addiction have found that attention and processing biases differentiate those high in substance abuse from those low in such, and also predict level of use over time (Field, 2006; McCusker, 2001, 2006; Stacy & Wiers, 2006). These cognitive biases are thought to arise as substances are experienced as favorable and habitually used (McCusker, 2001, 2006).

While it is understood that heritable, environmental, and niche-related risk factors contribute to level of substance abuse, little is known about the mechanisms supporting the relationships between these risk factors and the biases in expectancy, attention, and cognitive processing characteristic of substance abusers (Munafò & Albery, 2006). A cognitive focus on immediate survival, supported by implicit processes, may operate to translate these heritable and environmental risk factors into choice of niche and cognitive biases for substance related stimuli, which then contribute to the maintenance of behaviors aimed at acquiring and consuming substances.

Purpose of the Study

The purpose of this study is to test for an immediate survival focus (ISF). Such a focus is theorized to be associated with neighborhood danger and short-term strategies aimed at resource acquisition and threat avoidance (i.e., fast life history strategies). A reliance on implicit cognitive processes is suggested as the vehicle of this hypothesized short-term focus, and substance abuse, fight, flight, and prosocial behavior are

theoretically linked to implicit processes. In this study aggression is used as an indicator of fight (i.e., an approach response to threat), and submission is used as an indicator of flight (i.e., an avoidant response to threat). Aggression, submission, and prosocial behavior are specified in models tested to determine if the variance in substance abuse is, along with the variance in other constructs linked to implicit processes, subsumed by a latent factor representing an immediate survival focus, and to test if the ISF is associated with environmental conditions.

Limitations of the Study

This study is limited by the sample chosen, the use of proxy indicators of submission, the absence of direct measurement of cognitive processes, and a reliance on self-report data. First, the sample in this study is comprised of secondary students in the United States, a group characterized by many unique cultural and developmental attributes. Inferences drawn from these data should not be extrapolated to populations that are differentially aged or of different geographic locations.

Second, in this study items measuring victimization were used as proxy indicators of submission. This produces a concern related to the validity of the submission construct, and a possible limitation to the generalization of this study's findings. While victimization may be a very reliable correlate of trait submission, and the case for this is laid out in the review of the literature, some error is introduced with the use of its indicators. For illustration, it is possible to imagine that one could be victimized without ever submitting, however infrequently such may occur. Likewise, one could imagine submitting and not being victimized. Indeed, a substantial degree of submission is known

to occur at the implicit and often unconscious level of cognition, for the very purpose of deciding dominance status without more serious confrontation (van Honk, Schutter, Hermans & Putman 2004). However, an indicator of social exclusion is included, which should account for this latter possibility. Further, while submission may not be essential to victimization, and vice-versa, the data appear to suggest that on average individuals are both submissive and victims because they are smaller in size and lack prosocial tactics for achieving status (Crick & Bigbee, 1998; Hodges & Perry, 1999; Troy & Sroufe, 1987). In summary, this study uses victimization items as imperfect proxy indicators of trait submission. Thus, the study's results should be interpreted with a degree of caution proportional to the error that may exist in such measurement.

Third, this study relies exclusively on self-report data. Several limitations to such data are now widely known. For example, self presentation bias may introduce substantial error in the measurement of this study's constructs. Aggression may be underreported to some degree, as in United States such behavior is often frowned upon and socially sanctioned. Similarly, substance abuse may also be underreported, especially with respect to the use of substances which are widely disfavored (e.g., crack cocaine). In addition, self-report data are subject to the limitations of long-term memory, which has been shown to distort past events to an extent.

In spite of the limitations of self-report data, they are economical and robust enough that their use is very common. In this study the error introduced by memory is noted but not expected to be substantially systematic. However, reliance on self-report data is expected to decrease the strength of the relationships associated with variables

such as aggression and substance abuse, and the possibility that self-presentation bias may produce non-significant relationships related to these variables is of some concern.

Finally, these data are limited with respect to the inferences they can support regarding implicit cognitive processes. Researchers have used both explicit and implicit measures to tap cognitive processing. It is now well known that study participants often have limited insight into the nature of their own implicit processes, reducing the ability of explicit measures of cognition to reliably predict and explain behaviors supported by implicit processes (see Munafo & Albery, 2006). As a result of this limitation researchers developed implicit measures to tap the related processes (Munafo & Albery, 2006). In this study neither type of measure is employed. Instead, a latent factor hypothesized to represent a reliance on implicit processes is tested for, and it should be kept in mind that this does not represent a direct measure of implicit processes. Rather than being viewed as direct support for the existence of the hypothesized reliance on implicit processes, the results of this study should be viewed as either consistent or inconsistent with the notion that some people may rely on implicit processes. Rejection of the hypothesized model would suggest that the constructs specified in this study do not have a factor in common; rendering it unlikely the implicit processes could link the constructs. Acceptance of the model speaks to the possibility that this common factor exists, thus suggesting the greater likelihood that implicit processes link the study's constructs; but it cannot be concluded that indeed the common factor truly represents an aspect of cognition. This inference would require a more direct measure of cognitive processes.

Significance of the Study

This study may contribute to the literature viewing substance abuse and addiction through an evolutionary lens, along with the literatures on cognition and addiction, self-regulation, and adolescent substance abuse treatment and prevention. This study may also contribute to the literatures related to adolescent aggression, submission/victimization, and prosocial behavior.

The existence of an immediate survival focus (ISF) could provide grounds for viewing substance abuse behaviors within an evolutionary meta-theoretical framework. Within this framework substance abuse behaviors would be viewed as maladaptive strategies aimed at species typical goals. The ISF might be viewed as an adaptation to particular circumstances in which our ancestors found themselves. Survival for our ancestors may have often required snap judgments and immediate action. Today such an adaptation might be observed in individuals with a heritable predisposition to rely on it, and in individuals exposed to environments or circumstances that might lessen their chances of achieving species typical goals in the more distant future. Such individuals may tend to rely on implicit cognitive processes that provide quick evaluations for the purpose of achieving species typical goals in the short-term. This would serve the purpose of successful reproduction in contexts where long-term survival is improbable, and where planful or deliberative pursuit of species typical goals is not adaptive due to threat or lack of resources.

The ISF may be understood as a regulatory focus, similar to the promotion and prevention foci identified by Shah & Higgins (1997; see also Higgins & Spiegel, 2004; Higgins, Shah, & Friedman, 1997). Where the promotion and prevention foci are

characterized by either a preference for strategies aimed at nurturance or security, the ISF may represent a preference for short-term strategies aimed at either or both.

As mentioned above, the ISF could provide a link between risk factors for substance abuse and the cognitive biases characteristic of substance abusers. Such a focus could provide a target for substance abuse prevention and intervention efforts. As the ISF would be characterized by particular biases in evaluative processing, it could provide a ground for assisting substance abusers in identifying how they might make maladaptive judgments, along with the resultant cognitive biases they hold. The existence of an ISF could shed light on the mechanisms by which cognitive distortions (i.e., irrational beliefs; see Beck, 1993; Gilbert, 1998), often thought to plague those high on substance abuse, arise. In the present framework these cognitive distortions would be considered false positives in the identification of resources and threats critical to survival and reproduction.

Inquiry into an ISF may shed light on the mechanisms by which risk factors for aggression and submission/victimization are translated into the related behaviors. An ISF would be expected to have a positive association with behaviors focused on more immediate survival. Two types of such behaviors would be those characterized by fight or flight (Gilbert, 1998; Nesse, 1994; van Honk & Schutter, 2007). These types of behavior are characterized by implicit evaluation and quick behavioral initiation, and represent possible responses to perceived immediate social threats (van Honk & Schutter, 2007). According to van Honk et al. (2000), human anger represents the motivation to protect oneself through readiness for fight, while anxiety represents the motivation to protect oneself through avoiding the possibility of encountering aggression. The

behaviors associated with these motivations are dichotomized as approach or avoidance behaviors such as aggression or submission.

Finally, inquiry into an ISF could shed light on the mechanisms by which prosocial behaviors are decreased or inhibited. In contrast to the positive relationship between an ISF and aggression and submission, an ISF would be expected to have a negative relationship with prosocial behavior. This expectation hinges on relationships between traits associated with prosocial behavior and activity in the frontal cortex (MacDonald, 1995), and on the relationships between low levels of deliberation (i.e., impulsivity) and delinquent and anti-social behaviors (Robbins & Bryan, 2004).

Research Questions

This study proposes the existence of an immediate survival focus, supported by implicit cognitive processes. If this ISF exists, it should be positively associated with behaviors that rely on implicit cognitive processes and negatively associated with behaviors that rely on explicit processes. In addition, it should be positively related to neighborhood danger because fast life history strategies and implicit cognitive processes appear to be associated with unpredictable or dangerous environments. The literature review below delineates these theoretical linkages. For introductory purposes, the basic questions of this research are (1) Does an immediate survival focus exist? (2) Is it associated with substance abuse, aggression, submission, prosocial behavior, and neighborhood danger? (3) Finally, is the ISF positively associated with substance abuse, aggression, submission, and neighborhood danger, while being negatively associated with

prosocial behavior? More technical research questions of greater specificity are included in the methods section. Figure 1 represents the conceptual model to be tested.

Figure 1
Conceptual Model

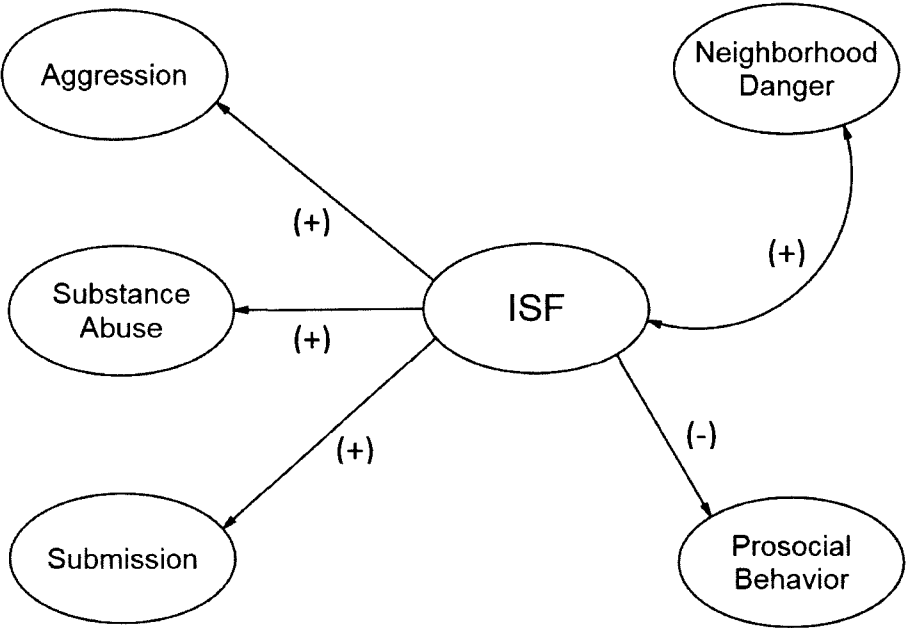

CHAPTER II

Review of the Literature

Scope of the Literature Review

Following a discussion of the grounds for viewing substance abuse as a problem, this review delineates the literature related to an evolutionary meta-theoretical framework for substance abuse. Human behaviors are largely conceived of as strategies aimed at achieving species typical goals (see Buss, 1991), and the cognitive architecture of the human mind is viewed as a collection of mechanisms acted on by natural selection. The mechanisms that facilitated achievement of species typical goals have been preserved, while those that provided significant disadvantage to our ancestors have been discarded. Following this aggression, submission, and prosocial behavior are considered as survival strategies, and the literature related to such a view is explored. The literature on implicit and explicit cognition is then delineated in a discussion providing a cognitive theoretical ground for understanding the ISF and its relationships to substance abuse, aggression, submission, and prosocial behavior. Finally, an evolutionary and cognitive view of substance abuse is summarized.

Substance Abuse Prevalence/Significance

In the year 2000, individuals in the United States lost approximately 537,000 of their fellows to substance abuse related causes, and in 2002 the estimated economic cost of substance abuse in the U.S. was 180.9 billion dollars (Mokdad, Marks, Stroup, &

Gerberding, 2004; ONDCP, 2004). This estimate includes resources expended in addressing the health and crime related consequences of drug abuse, along with loss of productivity due to disability, death, and withdrawal from the workforce. According to the Office of National Drug Control Policy (ONDCP; 2004), the cost of drug abuse increased about 5.3% every year from 1992 to 2002. The estimated cost of substance abuse in 1992 was 107.8 billion dollars (ONDCP, 2004). Interestingly, 71.2% of the cost of drug abuse in 2002 was productivity related, with healthcare costs totaling only 8.7% (ONDCP, 2004). About 60% of the total estimated cost of drug abuse is tied to crime-related loss of productivity. Much of this percentage is accounted for by loss of productivity due to incarceration.

The National Center on Addiction and Substance Abuse (CASA), in a more recent report, estimated the total governmental expenditure on substance abuse at all three levels of government (i.e., federal, state, & local). According to the CASA report (2005), when all levels were considered, the cost estimate for substance abuse reached a cool 467.7 billion dollars, or more than ten percent of the entire governmental budget.

According to CASA (2005):

Of every dollar *federal and state governments* spent on substance abuse and addiction in 2005, 95.6 cents went to shoveling up the wreckage and only 1.9 cents on prevention and treatment, 0.4 cents on research, 1.4 cents on taxation or regulation and 0.7 cents on interdiction. Under any circumstances spending more than 95 percent of taxpayer dollars on the consequences of tobacco, alcohol and other drug abuse and addiction and less than two percent to relieve individuals and taxpayers of this burden would be considered a reckless misallocation of public funds. In these economic times, such upside down-cake public policy is unconscionable. (foreword)

Substance abuse is therefore an enormous problem in terms of its economic cost, and there is a great disparity between the funds allocated for prevention and treatment, and those allocated for policing and incarcerating substance abusers.

At the levels of families and individuals, the cost of substance abuse extends beyond dollars and cents. A notable feature of addiction, the central feature in fact, is a marked loss of control over one's behavior (APA, 2000; McCusker, 2006). Addiction related disorders are usually characterized by consumption at greater frequencies and intensities than deliberately intended. According to McCusker (2006), these approach and consumption related behaviors persist in the face of increasing physical, psychological, and social costs. In the wake of these seemingly uncontrollable behaviors are destroyed careers, damaged bodies, broken relationships and families, psychological distress, and often incarcerations. According to Grant et al. (2004), substance abuse disorders (SUDs) were found to be among the most prevalent psychiatric disorders in the United States, with a rate of 9.35%. Only anxiety disorders were more prevalent, with a rate of 11.08%. Thus the costs related to SUDs appear to be some of the most frequently experienced in U.S. families dealing with a psychiatric disorder.

Theoretical Conceptualization

Survival by Substance Abuse. Evolutionary theory, as a meta-theoretical framework, has been successfully applied in areas of study such as medicine (Nesse & Williams, 1996), personality theory (Buss, 1991; MacDonald, 1995), and social neuroscience (Stone, 2007). Within scientific inquiry related to substance abuse, evolutionary theory generally argues for a view of substance abuse as a fundamental human tendency to be managed, rather than a disease to be cured (Nesse, 1994). Drugs, as primary reinforcers, manipulate our basic affective systems, giving rise to the experience of acquisition and consumption of essential resources, or to the experience of

escape of threat (Goldman et al., 2006; Margaron, 2004; Nesse, 1994). When viewed through the lens of evolutionary theory, substance abuse, while having many unique characteristics, is seen as comparable to the acquisition and consumption of other resources that are essential to survival, such as food, and to the avoidance and escape of threats such as social rejection (Nesse, 1994).

The rationale for viewing substance abuse as a human tendency to be managed stems from the dependence of the related behaviors on the same mechanisms that rendered our ancestors successful reproducers (Nesse, 1994). In other words, our ancestors successfully accomplished species typical goals that facilitated survival and reproduction, and some of the mechanisms by which these goals were accomplished are the same which render us vulnerable to substance abuse. Various components of the human brain were selected for over millennia and retained as a function of their relationship to the survival and reproduction of the organism. These components that contributed to our ancestors' fitness are basically tricked into evaluating drugs as favorable to survival, and into initiating and maintaining goal directed behaviors designed to approach and consume substances. For example, Goldman et al. (2006) indicated that:

Alcohol works on the system for tagging stimuli as biologically significant (via direct effects on the dopamine system, i.e. 'incentive salience'), and on emotional/motivational systems, to make these memories more indelible and salient, and thereby more influential within the overall decision-making process that leads to (or is avoidant of) alcohol use. (pg. 164-165)

According to Buss (1993), human behavioral strategies are aimed at the achievement of species typical goals, as mentioned above. The species typical goals associated with humans are (1) successful intra-sexual competition; (2) mate selection; (3) successful conception; (4) mate retention; (5) alliance formation; (6) coalition

building and maintenance; and (7) parental care and socialization (Buss, 1993). Because substances are primary reinforcers, it might be reasonable to expect that substance abusers expect to achieve species typical goals through their acquisition. Fromme, Stroot, & Kaplan (1993) found that substance users reported positive expectancies including, but not limited to, increased sociability (e.g., more outgoing and energetic), liquid courage (e.g., more courageous, daring, brave, powerful, and creative), and sexuality (e.g., better lover, enjoy sex more, be sexier, could act out their fantasies). In addition, Klinger and Cox (2004) found current concerns of alcohol users which could be seen as representing concern over resource acquisition and relationship goals. Thus substance abuse may be seen as a means to some ends typical of the human species.

Buss (1993) also suggested that behavioral traits vary in a population when (1) alternative genetic determinants of behavior contribute to the use of alternative strategies; (2) early environments contribute to the use of varying developmental strategies; (3) individuals occupy niches that contribute to variation in behavioral frequencies; and (4) individual differences in morphology or ability contribute to differences in the effectiveness with which various strategies can be carried out. As noted in the section on the prevalence and significance of substance abuse as a problem, the benefits of consuming substances are rather short-term (e.g., positive affect), while costs to health and other aspects of human functioning are accrued over time and as frequency and severity of consumption increase (CASA, 2005; McCusker, 2006; ONDCP, 2004). Further, there is substantial evidence indicating that those characterized by high levels of substance use have short-term time horizons, or time perspectives (Adams, 2009; Petry, Bickel, & Arnett, 1998; Robbins & Bryan, 2004; Zimbardo & Boyd, 1999). As

substances seem to provide the experience of short-term acquisition and consumption of resources (e.g., via positive affect, expectancies, etc.), it might be feasible to expect that substance abusers are characterized by genes, early environments, and niches that are associated with short-term survival.

Substantial empirical support for the above exists. Heritable differences in sensation seeking, or optimal level of stimulation, represent a genetic basis for the employment of short-term survival strategies (Stoel et al., 2006; Zuckerman, 1996). Sensation seekers are often characterized by substance abuse, affect-based decision making (i.e., impulsivity), and risky behaviors, all of which contribute to mortality (Laub & Vaillant, 2000; Robbins & Bryan, 2004). Substance abusers have also been found to be characterized by lower quality parental relationships, lower family cohesion, and greater family hostility (Nation & Heflinger, 2006). Hill, Ross, and Low (1997) suggested that such environmental unpredictability and risk inhibit delay in behavioral patterns related to survival and reproduction. Finally, associations between substance abuse and niches characterized by antisocial peers and delinquent and aggressive behaviors have been reported (Nation & Heflinger, 2006). Thus it seems there is some indication that substance abusers are characterized by genes, early environments, and niches associated with shorter-term survival.

A focus on immediate survival seems to characterize both the behavioral strategies employed and contexts inhabited by substance abusers. The environments survived by our ancestors (i.e., EEA) would have at times been characterized by greater resource scarcity and more threatening social environments. During these periods long-term survival was more uncertain, and thus shorter-term strategies for survival and

reproduction may have been more adaptive. At the level of cognition, such a focus on short-term survival and reproduction might have implied a heavier reliance on automatic cognitive processes, which are adapted to quick evaluation and behavioral execution. Today a reliance on implicit processes, as an adaptation to environments characterized by social threat, or due to a heritable predisposition to rely on such processes, may increase vulnerability to substance abuse. Such vulnerability may be associated with the effect of substances on the mechanisms supporting implicit evaluation of the biological significance of stimuli. That is, drugs may seem to have more biological importance to those at risk for false positives in the detection of resources and threats critical to survival and reproduction.

Survival by Aggression. Response to social threat has been observed to have a dual-sided nature (van Honk & Schutter, 2007). That is, socially threatening stimuli may be responded to with anger-driven dominance or anxiety-driven submission (van Honk et al., 2004). Anger-driven dominance represents an adaptation that allows individuals to avoid harm through readiness for fight (Lemerise & Dodge, 1993). Van Honk & Schutter (2007) review support for the associations of basal testosterone levels with anger, social aggression, and dominance. Here the anger-driven dominance motive (trait anger or dispositional anger) is discussed in terms of chronic instances of aggression.

While the general perception of aggression is negative in nature, there is little doubt that it is an adaptive response to certain social threats. Even philosophies that preclude defending oneself at the expense of a human attacker usually indicate that the life of another may be forcefully defended. According to Hawley (2003), aggression has often been associated with measures of psychological or behavioral maladaptation

including peer rejection, risk-taking behavior, low educational achievement, and unemployment. Consistent with the dual-sided nature of responses to social threat, Rubin, Hymel, and Mills (1989) suggested that aggressive-disruptive children and submissive-withdrawn children represent two behaviorally distinct subgroups of children at risk for social rejection (see also Perry et al., 1988). Despite these associations, it appears that some aggression is related to social competence (e.g., Hawley, 2003).

Social competence has traditionally represented adeptness for prosocial resource acquisition and control, in contrast to anti-social resource acquisition and control (i.e., use of aggression or coercion; Geary & Flinn, 2001; Penner, Dovidio, Piliavin, & Schroeder, 2005). Geary and Flinn (2001) suggested that during human evolution survival rate of children, increased parental investment, a lengthened human developmental period, increased child-initiated play, and greater social discourse co-varied with an increase in socio-competitive competencies. From the theoretical perspective of Geary and Flinn, parental investment does not only include the provision of physical resources, but social resources as well. When resource availability is high, social structure stable, and survival rate of children high, prosocial resource acquisition strategies are expected to be more prevalent in a group, and investment to increase the social competitiveness of fewer children would be more common (Geary & Flinn, 2001). When resources are scarce, and the survival rate of children is low, the stability of the social structure decreases, socio-competitive competence decreases, and the use of anti-social resource acquisition and control strategies increases in prevalence (Geary & Flinn, 2001).

As noted, in the environments survived by our ancestors (i.e., EEA), resources would have been scarce at times, and social environments more threatening. As long-term

survival was more uncertain during these periods, shorter-term strategies for survival and reproduction could have been more adaptive, and a heavier reliance on automatic cognitive processes, which are adapted to quick evaluation and behavioral execution, might have been implied. Consistent with the above, researchers have used the emotional Stroop task to demonstrate that unconscious emotion processing supports either dominance or submission motives in response to angry faces (for a review see van Honk & Schutter, 2007).

In modern industrialized contexts we find ourselves with plenty of resources. While unequal access to these resources is widely observed, the extent to which persons can access resources may be significantly determined, as theorized by Geary and Flinn (2001), by the degree to which they are socially competent (e.g., prosocial, cooperative, or conscientious). Indeed, personality traits such as conscientiousness and emotional stability have been found to be positively associated with career success (Judge & Kammeyer-Mueller, 2007; Seibert & Kraimer, 2001), and some employers report applicant attitude and communication skills as the two most important characteristics considered when hiring employees (Barton, 2006). Similarly, substantial support has been found for the associations between paternal investment in children, social competence, and upward social mobility (Geary & Flinn, 2001).

Aggression may provide short-term access to resources and successful reproduction. However, when employed frequently and chronically in modern industrialized contexts, this strategy may also lead to peer rejection and limited resource access. The relationships between aggression and peer rejection, risk taking behavior, low educational achievement, and unemployment have been noted. Such relationships suggest

that aggression may be associated with a more urgent or short-term attempt at survival and reproduction, and may achieve these short-term goals at the expense of long-term survival and relative comfort in a society characterized by substantial wealth and life prolonging technology.

Survival by Submission. The other side of the response-to-social-threat coin is anxiety-driven submission (van Honk et al., 2004). Anxiety-driven submission is an adaptation that allows individuals to avoid social threat, or reduce the possibility of experiencing aggression (van Honk et al., 2000). Van Honk and Schutter (2007) review support for the associations between basal levels of cortisol and anxious, avoidant, and submissive behaviors. Here the anxiety-driven submission motive (i.e., trait anxiety or dispositional anxiety) is discussed in terms of chronic instances of victimization.

In our ancestors' EEA, resources would have been scarcer at times and social environments more threatening. Within-group conflict would have occurred with greater frequency. When individuals could not achieve dominance in such conflicts, they would have been left to either submit or incur a greater risk of harm. Submission, or avoidance, may have served many of our ancestors well (largely implicitly) in the escape of physical harm, that they might live to achieve species typical goals another day. Trait submission, or withdrawal, may therefore represent an adaptation to surviving social contexts characterized by bigger, stronger, aggressive peers. Indeed, Crick and Bigbee (1998) noted that aggressive bullies are often bigger than their victims, and thus the risky nature of retaliation may contribute to victim submissiveness. In addition, children with internalizing problems (e.g., submissiveness) may be likely victims because aggressive peers view them as easy targets (Crick & Bigbee, 1998; Troy & Sroufe, 1987). Hodges

and Perry (1999) found that both internalizing problems (e.g., withdrawal and anxiety) and physical weakness independently predicted gains in peer victimization over time. Fox and Boulton (2005) found that non-victims were rated, using self, peer, and teacher ratings, as more likely to fight back than victims, and that victims were characterized by submissive behavior (e.g., stands in a way that looks like he/she is weak). Crick and Bigbee (1998) found that submissiveness is associated with both overt and relational victimization, and suggested that “submissiveness may be a hallmark of victimization regardless of the form of peer maltreatment” (p. 346).

Gallup, O’Brien, White, and Wilson (2009) discussed an evolutionary framework for peer victimization in which aggressors and victims are largely engaged in intra-sexual competition over resources and mates. They found that 72.59% of female victimization and 91.39% of male victimization was perpetrated by same-sex peers, and that most forms of victimization were associated with number of sexual partners (Gallup et al., 2009). Victimization among males was associated with fewer sexual partners, while victimization among women was associated with a greater number of sexual partners, providing support for the a priori predictions of the evolutionary theory (Gallup et al., 2009). As expected, more victimized males had fewer sexual partners, and female victimization did not have a negative relationship with number of partners. Gallup et al. discussed possible explanations for the positive relationship between female victimization and number of sexual partners including the possibility that males pressure females characterized by poor social skills for sex, and the possibility that females envy and demean more attractive females.

Positive relationships between peer victimization and a host of maladaptive psychological outcomes have been detected. For examples, peer victimization has been reported to have a positive relationship with depression, socio-psychological adjustment problems, future social anxiety, long-term unemployment, lower lifetime income levels, lower educational attainment, and greater likelihood of being single in adulthood (Gallup, et al., 2009). In a meta-analytic review, Hawker and Boulton (2000) found statistically significant associations between victimization and depression, loneliness, generalized and social anxiety, and global and social self-worth. According to McEwen, the affectively driven changes in information processing known as flight, once an adaptive response to threats, may today contribute to the etiology and maintenance anxiety disorders (in van Honk & Schutter, 2007, p. 199).

Similar to aggression, victimization may represent the result of reacting to social threats with a focus on immediate survival. In contexts where long-term survival was more uncertain, shorter-term strategies for survival and reproduction could have been more adaptive, and a heavier reliance on automatic cognitive processes, which are adapted to quick evaluation and behavioral execution, might have been implied. Indeed, van Honk & Schutter (2007) reviewed studies providing support for the association between the mechanisms supporting implicit processes and submission motives. While submission or acquiescing to dominant members of a social group may have allowed our ancestors to survive and reproduce, today trait submission, or chronic victimization by proxy, may function to prevent individuals from controlling resources and reaping the benefits of a modern industrialized society (e.g., technologies). Once a successful survival strategy in ancestral environments, today submissiveness may operate at the

expense of long-term survival and relative comfort in wealthy and technological societies. The negative relationships between victimization and long-term unemployment, lifetime income levels, educational attainment, and likelihood of having a spouse in adulthood have been noted.

Survival by Prosocial Behavior. Penner et al. (2005) characterized prosocial behavior as broad class of behaviors generally thought to benefit others. From an evolutionary perspective, the first mechanism that might contribute to prosocial behavior is reciprocal altruism (Trivers, 1971). Reciprocal altruism denotes the notion that if one does a favor for another, this favor may increase fitness if it is repaid. Such tit-for-tat strategies have been observed to have the greatest success of all strategies used in Prisoner's Dilemma games (Penner et al., 2005).

The second mechanism that might contribute to prosocial behavior is kin selection. Kin selection refers to the notion of inclusive fitness, where the transmission of genes to the next generation, by all sources, is considered (Hamilton, 1964). Penner et al. (2005) reviewed empirical support for kin selection, including, for example, the finding that individuals are more likely to help healthy relatives than non-healthy relatives in life-or-death situations.

Finally, the third evolutionary mechanism theorized to contribute to prosocial behavior is group selection, which, although refined theoretically, has not been subjected to extensive empirical testing (Penner et al., 2005). Group selection denotes the notion that altruistic groups will have an advantage over non-altruistic groups because more individuals will sacrifice themselves for the group.

At any given moment few of us are producing all the resources necessary for survival. Some of us have food we have grown while others have clothing they have made. Through sharing, or cooperating in coalitional fashion, our ancestors acquired necessary resources often enough that their descendants are alive today (see Geary & Flinn, 2001). As discussed in the introduction, the human ability to control anger and anxiety, and to create and carry out plans, appears to have been associated with dramatic change in the manner by which our ancestors shared, and also survived. Today we use plastic cards to give people across the world currency for shoes, which they may then use to buy leather from us.

In addition to the material benefits acquired through sharing, negative relationships between prosocial behavior and peer rejection, loneliness, aggression, hostility, cheating in school, and social adjustment difficulties have been observed (Crick, 1996; Hawley, 2003; Parkhurst & Asher, 1992; Rose-Krasnor, 1997). In addition, positive relationships between prosocial behavior and social adjustment, peer acceptance, resource control, positive self-concept, and positive affect have been reported (Crick, 1996; Hawley, 2003; Parkhurst & Asher, 1992). Crick (1996), along with Parkhurst and Asher (1992), noted that the combination of aggressiveness and/or submissiveness with low levels of prosocial behavior is particularly problematic for children (e.g., leads to peer rejection).

At least in modern industrialized societies, prosocial behavior appears to be largely associated with positive outcomes, while higher levels of aggression and submissiveness seem to be associated with negative outcomes. As long-term planning seems to be associated with the cooperative use of resources, explicit cognitive processes

may be those that largely support such modern prosocial behavior, while a reliance on implicit processes may partially inhibit such behavior. Evidence consistent with this notion includes studies demonstrating that conscientiousness, the personality trait representing planfulness and aspects of prosocial behavior such as virtue (i.e., honesty, morality, and “good Samaritan” behavior) and responsibility (i.e., service to others, contribution of time and money to community projects, and tendency to be cooperative and dependable; Roberts et al., 2005), is associated with activity in the frontal cortex (MacDonald, 1995). Further, relationships have been observed between facets of impulsivity, the conceptual antithesis of conscientiousness, and aggression (Vigil-Colet & Codorniu-Raga, 2004). Aspects of impulsivity have been observed to be associated with anxiety and vulnerability as well (Whiteside & Lynam, 2001). Together these findings suggest that greater deliberation may be related to prosocial behavior, while impulsivity or lesser deliberation may be related to constructs negatively associated with social competence.

Implicit and Explicit Cognitive Processes. According to Goldman et al. (2006), the brain is a collection of mechanisms adapted to the anticipation of the future. That is, we are generally disposed to formulate predictions about the future and act on them, and these predictions derive much of their worth from the degree to which they facilitate reproduction. Those primates that made many serious errors in predicting their futures are not our ancestors, where such errors would have been those predictions that led to harm rather than to survival and reproduction.

Humans have two relatively distinct sets of mechanisms in their brains that support two types of cognitive processes (see Cunningham, 2004, 2007; Lieberman,

2007; Redish et al., 2008; Stacy & Wiers, 2006). The first set supports faster, more automatic processes, while the second set supports slower, more deliberative processes. The first set requires fewer neural resources, while the second requires more. Those cognitive processes that are more automatic, faster, and require fewer neural resources have been termed implicit processes, while the slower, more deliberative and resource consuming processes have been termed explicit processes. Implicit processes provide us with the ability to make snap judgments when faced with danger or brief availability of valuable resources. These processes are those used when evaluating what to do as a grizzly bear approaches, and when carrying out behaviors that have been frequently used. Explicit processes provide us with the ability to solve complex problems, exert self-control, and to formulate and execute plans. These processes are those used when deciding how to cross a river, or when inhibiting maladaptive automatic responses to stimuli. For example, the best response to a grizzly bear attack might be playing dead, which may not automatically occur to many people. Such a response would require executive control and planning.

Implicit cognition and substance abuse. The distinction between implicit and explicit processes has provided insight into many areas of psychological science, including the formation of habits, the construct validity of self-report measures, and the great difficulty in behavior change (Munafò & Albery, 2006). Related to substance abuse, researchers have found that substance related stimuli engage implicit processes in those high in substance abuse severity, while no comparable response is observed in controls (Field, 2006). It appears that repeated use of substances is associated with a shift from the use of deliberate behavioral control to automatic behavioral control (i.e., habit formation;

see McCusker, 2006; Redish et al., 2009). This finding led to research shedding light on the puzzling inability of expectancies to reliably predict relapse (for a review see McCusker, 2006). Specifically, in samples of participants in treatment for substance abuse, the number of negative expectancies related to substances was not significantly associated with relapse. Using tests of implicit processes, researchers found that though individuals high in substance abuse reported more negative expectancies than controls, their positive expectancies were accessed faster than their negative expectancies (McCusker, 2001, 2006). In those high on substance abuse, negative expectancies related to substances were more slowly accessed through deliberation. Thus those high in substance abuse seem carry out the related behaviors using automatic cognitive processes, or habitually.

Other support for the notion that implicit processes underpin substance abuse comes from research on impulsivity. Either deficiency in higher-order processing or overactive implicit processes may be associated with aspects of impulsivity (i.e., disinhibition; Vigil-Colet & Codorniu-Raga, 2004). In either case, a reliance on implicit cognition might be observed. A robust association between impulsivity and substance abuse has been found (Terry, Moeller, Rhoades, & Cherek, 1997). Conversely, conscientiousness, or the degree to which one is not impulsive (e.g., planful), has been observed to have a negative relationship with substance abuse (Bogg & Roberts, 2004).

As insinuated, researchers have experienced difficulty identifying whether it is hyperactive implicit processes or underactive deliberative processes (i.e., executive control deficits) that are related to impulsivity. In the absence of brain injury or fMRI data, the two possible mechanisms supporting impulsivity are often indistinguishable.

Social neuroscientists have found that to a substantial extent, implicit or explicit processes are activated in a mutually exclusive manner (Lieberman, 2007). For example, biologically relevant pictures may take an evolutionary old shortcut to the limbic system (van Honk & Schutter, 2007), and at times explicit processes may inhibit implicit processes (e.g., take control of the habit system; Lieberman, 2007). It may be reasonable to expect that cognitive deficits are characterized by greater temporal stability than hyperactive implicit processes, which in many cases could be more sensitive to early environment and present context. For example, implicit processes may be responsive to threatening stimuli in the lab, or possibly, as hypothesized in this study, to neighborhood danger.

It would be maladaptive to decide each morning whether it is a good idea to brush your teeth, just as it would be cumbersome to figure out how tie a shoe each time you needed to. As we carry out behaviors each day, the value and outcomes of these behaviors cease to be deliberated upon, and the behavioral sequences become automatic (Redish et al., 2008). To some degree our world is not predictable, and each day brings new problems, some of them quite complex. It would not be adaptive to apply our past habits or expectancies to every new context. Thus we find we have brains adapted to our world, able to tackle complex problems with flexibility, while also able conserve resources by automatically and quickly dealing with familiar circumstances, threats, and scarce resources. As anticipatory mechanisms, our brains make many predictions automatically, or in a fixed manner, while other predictions are left to a relatively open system.

Implicit Cognition, Aggression, and Submission. There is substantial evidence suggesting that implicit cognitive processes are, in addition to being associated with substance abuse, related to aggression and submission. Fight and flight are two evolutionary old responses to threat, as are the supporting mechanisms of the brain (van Honk & Schutter, 2007). According to MacDonald (1995), organisms must approach the world for resources, and also avoid threats. The cognitive mechanisms supporting behavioral approach are associated with positive affect, extraversion, dominance, sensation seeking, and aggression (MacDonald, 1995). In addition, the externalizing disorders (e.g., substance use or conduct disorder) are associated positively with behavioral approach (MacDonald, 1995). Conversely, the mechanisms supporting avoidance are associated with internalization, or neuroticism (e.g., negative affect, anxiety, and depression; Griffith et al., 2009; MacDonald, 1995).

The mechanisms supporting behavioral approach and avoidance (e.g., fight and flight) appear to be associated with implicit cognition. Putman et al. (2004) found that, in a modified Stroop task with a masked task condition, individuals with higher levels of social anxiety selectively attended away from angry faces. This effect was found only in the masked condition, suggesting that unconscious emotion processing may provide a better measure of motivated attention than conscious emotion processing. Similarly, van Honk & Schutter (2007) reviewed studies reporting a positive association between trait anger and attention vigilance toward angry faces in both masked and unmasked conditions. These results are not surprising in light of evolutionary accounts of human behavior which posit that aggression and submission are responses to threats, and therefore must be quickly carried out.

An Evolutionary and Cognitive Framework. This study hypothesizes an immediate survival focus which would be associated with a short-term approach to both resource acquisition and threat avoidance. Substance abuse is thought to be experienced as resource acquisition and consumption, or threat avoidance, with a focus on the short-term realization of species typical goals. A reliance on implicit cognition is suggested as the vehicle of this hypothesized short-term focus, and there is some indication that implicit processes are associated with each of aggression, submission, and substance abuse. Additionally, there is some evidence suggesting that prosocial behavior is associated with explicit processes, which have been observed to operate to the relative exclusion of implicit processes. Finally, there is some indication that unpredictable, or unsafe, environments may be associated with a short-term focus on survival. Thus, it is hypothesized that a single latent factor representing an immediate survival focus will subsume the variance in each of these constructs, having a positive relationship with neighborhood danger, aggression, submission, and substance abuse, and a negative relationship with prosocial behavior.

Alternative Models. Here it has been theorized that an immediate survival focus (ISF) may be associated with neighborhood danger, substance abuse, aggression, submission, and prosocial behavior. Another possibility is that neuroticism links these constructs, and associations between neuroticism (i.e., negative affect) and substance abuse, aggression, and submissiveness/victimization have been reported (Edmunds, 1977; Sharpe & Desai, 2001; Terraciano et al., 2008). Here the ISF is theorized to have effects on manner of resource acquisition in addition to manner of dealing with threats, as substance abuse and aggression have both been observed to be associated with behavioral

approach, or externalization (Kendler et al., 2003; Nobile et al., 2007). Neuroticism is primarily associated with internalization and avoidance (Figueredo et al., 2005; Griffith et al., 2009; MacDonald, 1995), or submission motives (van Honk & Schutter, 2007). Thus, replacement of the latent construct, ISF, with neuroticism is expected to result in a loss of information, and thus a poorer model fit to the data, compared with a model where neuroticism is specified as an endogenous construct along with aggression, submission, and prosocial behavior.

In addition to neuroticism, the constructs impulsivity and/or compulsivity could subsume the variance in the constructs theoretically linked to the ISF. Associations between impulsivity and aggression, submission, substance abuse, and prosocial behavior have been observed, many of which have been reviewed here. In addition, compulsivity has been linked to substance abuse, where compulsive behaviors are those which individuals are unable to inhibit (Torregrossa, Quinn, & Taylor, 2008). Within this theoretical framework impulsivity and compulsivity would be considered behavioral traits rather than cognitive variables. Behavioral traits are theorized as outward behaviors while cognitive constructs are thought to be inner mental processes or mechanisms. The difference is manifest at measurement, where behavioral traits are often measured through self-reported recollections of behavior (for measurement of impulsivity see Whiteside & Lynam, 2001). Cognitive variables may be measured by self-report as well, but usually tap some present aspect of cognition rather than behavioral history.

Unfortunately the present dataset does not include measures of impulsivity and/or compulsivity. If such measures were available they would be hypothesized as an endogenous constructs along with aggression and submission. That is, they would be

hypothesized as potential behavioral outcomes associated with an ISF, rather than as the factors linking neighborhood danger with aggression, submission, substance abuse, and prosocial behavior. An immediate survival focus would be expected to subsume the variance in both of these constructs. A reliance on implicit processes, in association with harsh or dangerous environments, could explain both the disinhibition of behavior aimed at short-term survival, and false positives in the detection of resources and threats critical to survival. These false positives could be the basis for compulsive behaviors. For now, the relationships of impulsivity and compulsivity to the present constructs will remain for future research to elucidate.

Finally, the K-factor, or slow life history, could subsume the variance in the constructs theoretically linked to the ISF. The K-factor has been linked to some forms of aggression, submission/victimization, and prosocial behavior (Ellis et al., 2009; Figueredo, et al., 2005, 2006; Kruger et al., 2008). However, as with impulsivity, the K-factor would need to be a cognitive construct to fit into the present theoretical framework. To my knowledge this possibility has not been ruled out. The K-factor may very well represent the principle of expectancy in what Goldman et al. (2006) suggested may be the “functional outcome of epigenesis” (p. 149). That is, cognition may function to anticipate, implicitly or explicitly, what combination of circumstances and strategies will best lead to reproduction, and act toward the combination of the optimal strategies and contexts. High K individuals would have predicted that waiting is optimal for reproduction, while low K individuals would have predicted that waiting is too risky or provides no reproductive benefit. Cognition may link genes and environments to life history strategy use over time, but this remains a question for future research, although

recent studies have found support for the possibility that executive functions play such a role (Figueredo et al., 2006).

Sex. Some of the constructs treated in this review have been observed to exhibit mean differences across sex. Females have often been found to be lower than males on some indicators of externalization, including substance abuse and physical aggression (MacDonald, 1995). Conversely, females have often been observed to score higher on some measures of internalization, including submissiveness and neuroticism (e.g., anxiety and depression; MacDonald, 1995). Evolutionary theorists have posited that these differences are associated with the differential level of investment required by each sex to reproduce (see Buss, 2007; MacDonald, 1995; Mealey, 2000). Males stand to lose less if offspring do not survive, and have been observed to employ strategies that are generally more risky or r-selected than females. Females stand to lose more if offspring die, benefitting more from avoidant or cautious behavior.

Informed by evolutionary theory, here it is theorized that an ISF would be characterized by a greater association with neighborhood danger among males than females. This is because responding to environmental harshness or unpredictability with automatic evaluations and short-term strategies (e.g., fight or flight) is theorized to hold more reproductive potential for males. In addition, a greater association between the ISF and aggression is expected among males, while a greater association between the ISF and submission is expected among females. This is theoretically rooted in the notion that in harsh/unpredictable environments males would realize greater reproductive benefit by employing aggression, while females would realize greater reproductive benefit by employing submission.

CHAPTER III

Methodology

Research Questions

Based on the literature reviewed, the following research questions have been posed:

- RQ1: Does a latent factor subsume substantial variance in the constructs neighborhood danger, substance abuse, aggression, submission, and prosocial behavior?
- RQ2: Does this factor have a positive relationship with substance abuse, aggression, and submission, and a negative relationship with prosocial behavior?
- RQ3: Does specifying neuroticism as a variable linking substance abuse, aggression, and submission result in a poorer model fit to the data, compared with a model in which neuroticism is specified as endogenous along with aggression and submission?
- RQ4: Do the associations between the ISF and the study's other constructs differ across the sexes?

Sample and Procedures

Cross-sectional data from the Health Behavior in School-Aged Children (HBSC) 2001-2002 survey, administered by the United States Department of Health and Human Services, were analyzed in this study. The HBSC survey collected data on a wide range

of health behaviors and indicators, and on factors influencing health. The sample included public, Catholic, and other private school students in grades 6, 7, 8, 9, and 10 in the 50 states and in the District of Columbia. Auxiliary questionnaires were completed by school administrators or lead health educators. A total of 348 schools and 15,245 students completed surveys. The HBSC survey was administered according to a probability sampling design. The U.S. survey was fully-weighted, and case weights are available in the dataset. In this study the sampling weights were not used. For more information on the HBSC survey, please see U.S. Dept. of Health and Human Services (2003).

In this study cases were limited to secondary students because data for substance use were not available for middle school students. In addition, many psychosocial and developmental characteristics differentiate middle school and secondary students (Broderick & Blewitt, 2006). Even if data on middle school substance use were available in this study, such developmental differences between these populations could have been expected to confound the results. For example, in many cases middle school students may not have begun expending substantial reproductive effort. Data for 9th and 10th grade students were available for analysis, and demographic information for the sample is displayed in Table 1.

Data for 5,356 cases were analyzed in this study. The percentage of data missing for the variables ranged from 2.4% to 12.6%, with an average of 8.6% missingness. Missing data for modeled variables were handled using the expectation maximization (EM) algorithm. The IBM SPSS 19 missing data package was used to conduct the imputation. Finally, the ratio of cases to freely estimated parameters was 86 to 1, easily

satisfying the minimum ratio often indicated for CFA studies (Bentler & Chou, 1987; but see Brown, 2010, p. 413).

Prior to the analyses the data were examined for violations to the assumptions of CFA and SEM. Some evidence of outliers was found. Two cases had leverage values 5 times greater than the sample average, and several items had skew statistics larger than 2. These violations of the distributional assumptions of CFA and SEM were handled using bootstrapping, which is available in the Amos 19 software package. Bootstrapping was also used as a method for overcoming the limitation of the EM algorithm in accounting for uncertainty in the imputation of missing data (Hudes & Neilands, 2007). The bootstrap method was Maximum Likelihood, 2000 samples were used, and the bias-corrected p -values and standard errors are reported in this study.

Table 1
Sample Demographic Information

	Frequency	Percent
Grade:		
9th grade	2706	50.5
10th grade	2650	49.5
Age:		
13	15	0.3
14	1574	29.5
15	2505	46.9
16	1151	21.5
17	95	1.8
Sex:		
Male	2572	48.0
Female	2784	52.0
Race:		
American Indian or Alaska Native	150	3.2
Asian	223	4.8
Black or African American	1136	24.3
Native Hawaiian or Other Pacific Islander	56	1.2
White	2909	62.1
Two or more races	210	4.5
Urbanicity:		
Urban area (city)	2353	44.8
Suburban area (near a large city)	1470	28.0
Rural area (not near a large city)	1435	27.3
Country of Birth:		
United States	4866	91.2
Other country	471	8.8
Language Spoken in Home:		
Only or mostly English	4046	76.0
Only or mostly a language other than English	421	7.9
English and a language other than English, about equally	855	16.1
Mother in Home:		
Yes	4797	89.6
No	559	10.4
Father in Home:		
Yes	3286	61.4
No	2070	38.6

Instruments

Items measuring perceived neighborhood danger, frequency of aggressive behavior, frequency of victimization, frequency and intensity of substance abuse, and perceived prosocial behavior were selected from the national survey. These items are displayed in Table 2 and were characterized by ordinal scales. For the measurement of the substance abuse construct, six items were selected. Two assessed frequency of beer and spirits drinking, two assessed frequency of marijuana use, one assessed frequency of tobacco smoking, and one assessed frequency of binge drinking (i.e., more than five drinks on one occasion). Items measuring beer and spirits use had five points, items measuring marijuana use had seven points, the item measuring tobacco smoking had four points, and the item measuring binge drinking had six points.

Six items were selected to measure the aggression construct. These items assessed both direct and indirect aggression, as both types are underpinned by the implicit dominance motive discussed in the literature reviewed. The selected items measured frequency of bullying others, physical assaults on others, name calling, sexual jokes, excluding others from the group, and rumor spreading. These items were theorized to reflect severity of the dominance motive among individuals. Five point scales were used to measure the construct.

Six proxy items were selected to assess submission. These items assessed both direct and indirect victimization, as both types are underpinned by the implicit submission motive discussed in the literature reviewed. The selected items measured frequency of being bullied, being physically assaulted, being called names, being the victim of sexual jokes, being left out, and being the victim of rumors or lies. These items

were theorized to reflect severity of the submission motive among individuals. Five point scales were used to measure the construct.

Five items were selected to measure perceived prosocial behavior. These items assessed the degree to which students perceived their peers to be prosocial, measuring the degree to which students believe that their peers help a student when they are down, enjoy each other's company, are kind and helpful, accepting, and create a safe environment at school. These items were theorized to reflect cooperative behavior. This construct was measured using 5-point Likert scales.

Finally, five items were selected to measure perceived neighborhood danger. These items measured disagreement with a statement indicating people say hello to each other on the street, a statement indicating that children are safe to play on the street, and a statement indicating that the individual could ask neighbors for a favor. These items were characterized by 5-point Likert scales. In addition, an item measuring how often participants felt safe in their neighborhood was used. This item was a 4-point scale.

The five scales were examined in SPSS 19 and descriptive statistics for the scales, including reliability coefficients, are reported in Table 3. The alpha coefficients reported were used to tentatively assess subscale reliability. It has been recognized that Cronbach's alpha coefficient misestimates scale reliability (Brown, 2006, p. 338). All scales were observed to have adequate levels of internal consistency (alphas > .70; Cronbach, 1954).

Table 2
Scale Items by Factor

Item	Scale/Factor	
85A*	Sub. abuse	At present, how often do you drink beer?
85C	Sub. abuse	At present, how often do you drink liquor/spirits?
87	Sub. abuse	During the past 30 days, how many times did you have five or more drinks on the same occasion?
88A	Sub. abuse	How often have you used marijuana in your life?
89A	Sub. abuse	How often have you used marijuana in the last 12 months?
83	Sub. abuse	How often do you smoke tobacco at present?
69*	Aggression	How often have you taken part in bullying another student(s) at school in the past couple of months?
		How often have you bullied another student(s) at school in the past couple of months in the ways listed below?
70C	Aggression	I hit, kicked, pushed, shoved around, or locked him or her indoors.
70A	Aggression	I called another student(s) mean names, made fun of, or teased him or her in a hurtful way.
70G	Aggression	I made sexual jokes, comments, or gestures to another student(s).
70B	Aggression	I kept him or her out of things on purpose, excluded him or her from our group of friends, or completely ignored him or her.
70D	Aggression	I told lies or spread false rumors about him or her and tried to make others dislike him or her.
66*	Victimization	How often have you been bullied at school in the past couple of months?
		How often have you been bullied at school in the past couple of months in the ways listed below?
67C	Victimization	I was hit, kicked, pushed, shoved around, or locked indoors.
67A	Victimization	I was called mean names, was made fun of, or teased in a hurtful way.
67G	Victimization	Other students made sexual jokes, comments, or gestures to me.
67B	Victimization	Other students left me out of things on purpose, excluded me from their group of friends, or completely ignored me.
67D	Victimization	Other students told lies or spread false rumors about me and tried to make others dislike me.
62D*	Prosocial Bx	When a student in my class(es) is feeling down, someone else in class tries to help.
62E	Prosocial Bx	The students in my class(es) enjoy being together.
62F	Prosocial Bx	Most of the students in my class(es) are kind and helpful.
62G	Prosocial Bx	Other students accept me as I am.
62C	Prosocial Bx	I feel safe at this school.
80*	Neighb. Dng.	Generally speaking, I feel safe in the area where I live.
81A	Neighb. Dng.	People say "hello" and often stop to talk to each other in the street.
81B	Neighb. Dng.	It is safe for younger children to play outside during the day.
81E	Neighb. Dng.	I could ask for help or a favor from neighbors.

Note. *Marker indicators.

Table 3
Analysis of Subscales

	# of items	Mean	Range of Means	SD	Alpha
Substance Abuse	6	11.93	.769	7.076	.865
Aggression	6	8.50	.341	4.316	.891
Victimization	6	8.71	.312	4.455	.869
Perceived Prosocial Behavior	5	17.21	.435	4.095	.785
Perceived Neighborhood Danger	4	8.12	.603	2.956	.732

Analyses

Confirmatory factor analytic (CFA) and structural equation modeling (SEM) techniques were used to test a measurement model and four structural models. The analyses were carried out in the Amos 19 software package. The raw data were used as input, variance-covariance matrices were analyzed, and the estimation method used was Maximum Likelihood. All tests of statistical significance were conducted at the $p < .05$ level. These analyses were carried out in four stages; with stage one including the testing of the measurement model using half of the sample data (resultant from a random split), and modification of this model based on statistical considerations (i.e., observation of modification indices and standardized residuals) and substantive rationale. Stage two was characterized by the testing of the hypothesized structural model using the same half of the data, modification of this model, and validation of this model using the other half of the sample. The split half method has been suggested for use in testing the stability of results in structural equation modeling techniques (Polhmann, 2004). Stage three included the testing of alternative models. In stage four the model was tested for fit to the data for each sex, and the structural portion was tested for invariance across the sexes.

Hypothesized Models. As noted, four full structural models were hypothesized. The first model included the latent factor, ISF, which was expected to subsume substantial variance in the exogenous variable, perceived neighborhood danger, and the endogenous variables (see Appendix B). The second model was an alternative model that did not include the ISF. Instead, this model included the exogenous variable, perceived neighborhood danger, and the endogenous variables, substance abuse, aggression, submission, and perceived prosocial behavior. Models three and four represented the testing of the possibility that neuroticism would better subsume the variance in the endogenous variables, substance abuse, aggression, submission, and perceived prosocial behavior. In model three, a variable representing neuroticism was specified in place of the ISF. In model four, neuroticism was specified as an endogenous variable along with substance abuse, aggression, submission, and perceived prosocial behavior.

Multi-Group Tests. The final best-fitting structural model was used as the baseline model for the test of model fit to the data for each sex (see Appendices C & D). Data for 2,572 males and 2,784 females were available for analysis, with no cases missing data for sex. In addition, multi-group invariance tests were carried out across the sexes for the structural portion of the model. This procedure was carried out to test the relative importance of the ISF to the constructs for each sex.

Goodness of Fit Criteria. The fit criteria considered in the analyses included the substantive meaningfulness of the model, the χ^2 likelihood ratio statistic, the Tucker-Lewis index (TLI), the comparative fit index (CFI), the Bayes information criterion (BIC), and the root means square error of approximation (RMSEA). A variety of indices were used because they provide different information about model fit. Relative to degrees

of freedom, large χ^2 statistics have been shown to indicate a need to modify models to better fit data, and this statistic has frequently been used to compare nested models (Byrne, 2001). The BIC is often used for model comparison as well – particularly with non-nested models – and differences in the BIC of greater than 10 are considered strong evidence of differential model fit. Lower values indicate better fits to the data (Raftery, 1995). The TLI indicates the relative amount of variance and covariance explained by the hypothesized model (Byrne, 2001), and ranges from 0 to 1. Values close to or above .95 suggest a good fit to the data. The CFI also ranges from 0 to 1, and results from comparison of the hypothesized model and the independence model. Hu & Bentler (1999) suggested that values of .95 or greater may be considered indicators of a good fit to the data. Finally, the RMSEA was used as an indicator of fit with sensitivity to degrees of freedom. Values of less than .05 are suggested to indicate a good fit (Browne & Cudeck, 1993).

CHAPTER IV

Results

Confirmatory Factor Analysis

The fit indices produced by stage one of the analyses are displayed in Table 4. The hypothesized five factor measurement model was tested for fit to the data, and the model was over-identified with 314 degrees of freedom. Observation of the fit indices suggested that this model provided an inadequate fit to the data, and therefore should have been rejected. A RMSEA value of greater than .05 was observed, as were CFI and TLI values that fell well short of .95.

Modification indices, standardized residuals, and substantive rationale were considered in identifying sources of misspecification in the model. Modifications were made upon observation of relatively large modification indices (i.e., here all were greater than 40), upon observation of standardized residuals greater than two, and according to substantive rationale. Five items were removed and three error covariances were added. Four of the items (i.e., Q62C, Q67C, Q67A, and Q62G) were removed due to evidence of indicator misspecification, observed here as salient loadings on two or more factors. One item (Q88A) was removed due to evidence that suggested it was highly redundant with another item (i.e., asked the same basic question, observed as extensive covariance between indicators and similar item wordings). Error covariances were specified when item wordings were similar but covariance was less extensive. All modifications to the

measurement model led to statistically significant decreases in the value of χ^2 , along with decreases in the observed BIC value greater than 10.

As a result of the modifications a well-fitting solution was achieved. This final measurement model was over-identified with 196 degrees of freedom and was characterized by an RMSEA value below .05 (i.e., RMSEA = .040), a CFI value of above .95 (i.e., CFI = .968), and a TLI value above .95 (i.e., TLI = .962). All observed fit statistics indicated that the model fit the data very well. For the final measurement model, the values of R^2 ranged from .21 to .82. The indicators specified appeared to reliably measure their respective constructs. All factor loadings, variances, and covariances were statistically significant with $ps < .001$. Observation of the modification indices and standardized residuals suggested that an area of substantial strain remained for the final measurement model. These indicators (i.e., relatively large MIs and standardized residuals > 2) suggested the specification of a covariance between error 9 (Q67G) and error 21 (Q70G). However, specifying this parameter did not result in improved model fit (e.g., Δ BIC smaller than 2) and resulted in an insubstantial parameter value (standardized beta substantially less than .20). Therefore, this parameter was not retained.

Table 4
Measurement Model & Modifications

	DF	χ^2	RMSEA	BIC	CFI	TLI
MM1	314	7027.025***	.089[.088-.091]	7533.025	.822	.801
MM2	289	2604.186***	.055[.053-.057]	3093.541	.929	.920
MM3	288	2320.743***	.051[.049-.053]	2817.991	.937	.929
MM4	287	2208.671***	.050[.048-.052]	2713.812	.941	.933
MM5	263	1932.660***	.049[.047-.051]	2422.015	.947	.940
MM6	240	1646.757***	.047[.045-.049]	2120.327	.953	.946
MM7	239	1511.042***	.045[.042-.047]	1992.504	.957	.951
MM8	238	1393.135***	.043[.040-.045]	1882.490	.961	.955
MM9	216	1185.812***	.041[.039-.043]	1659.382	.965	.959
FMM	196	1044.056***	.040[.038-.043]	1493.947	.968	.962

***= $p < .001$. 95% confidence intervals for RSMEA in brackets. MM1=Measurement Model; MM2=MM1-Q88A; MM3=MM2+cov (err6-err8); MM4=MM3+crossloading (submission-Q62G); MM5=MM4-Q62C; MM6=MM5-Q67C; MM7=MM6+cov (err4-err5); MM8=MM7+cov (err21-err23); MM9= MM8-Q67A; FMM= MM9-Q62G

Structural Equation Modeling

In stage two of the analyses the hypothesized structural model was tested for fit to the data (see Appendix B for the model). This model was over-identified with 201 degrees of freedom and resulted in a solution that fit the data substantially worse than the final measurement model (see Table 5). The CFI and TLI values decreased slightly from those observed for the final measurement model, the BIC value was substantially higher than that for the final measurement model (i.e., $\Delta BIC = 137.624$), and the χ^2 value was substantially higher as well (i.e., $\Delta \chi^2 = 177.088$, $\Delta df = 5$, $p < .001$).

Modification indices, standardized residuals, and substantive rationale were considered to identify the sources of misspecification in the model. As a result, two paths and one residual covariance were added. Modifications were made upon observation of relatively large modification indices – all greater than 10 in this case – and according to substantive rationale. A direct effect between perceived neighborhood danger and

perceived prosocial behavior was freely estimated along with a direct effect between perceived neighborhood danger and substance abuse. A residual covariance was freely estimated between the residual for substance abuse and the residual for submission. All modifications to the measurement model led to statistically significant decreases in the value of χ^2 , along with decreases in the observed BIC value that were greater than ten. Descriptions and rationales for these effects are discussed in the following pages.

The modifications to the structural model yielded a well-fitting solution (see Table 5). This final structural model was over-identified with 198 degrees of freedom, and was characterized by an RMSEA value below .05 (i.e., RMSEA = .040), a CFI value above .95 (i.e., CFI = .968), and a TLI value above .95 (i.e., TLI = .962). All observed fit statistics indicated that the model fit the data just as well as the final measurement model (e.g., $\Delta\text{BIC} < 10$ and $\Delta\chi^2 = \text{NS}$). For the ISF, the values of R^2 ranged from .08 to .53, indicating the ISF explained substantial variance in the other modeled constructs. All unstandardized betas (see Table 6), variances, and covariances (see Appendix A) were statistically significant with $ps < .001$. Observation of the modification indices and standardized residuals suggested that no areas of substantial strain remained for the final structural model.

Table 5
Full Structural Model & Modifications

	DF	χ^2	RMSEA	BIC	CFI	TLI
FMM	196	1044.056***	.040[.038-.043]	1493.947	.968	.962
SEM1	201	1221.144***	.044[.041-.046]	1631.571	.961	.955
SEM2	200	1111.306***	.041[.039-.044]	1529.626	.965	.960
SEM3	199	1072.164***	.040[.038-.043]	1498.377	.967	.961
FSEM	198	1047.144***	.040[.038-.042]	1481.249	.968	.962
FSEM2	198	1130.004***	.042[.040-.044]	1564.109	.962	.956

*** $p < .001$. 95% confidence intervals for RSMEA in brackets. FMM=Final Measurement Model; SEM1=Hypothesized Structural Model; SEM2=SEM1+path (Neighborhood Danger-Prosocial Bx); SEM3=SEM2+cov (res2-res3); FSEM=SEM3+path (Neighborhood Danger-Substance Abuse); FSEM2=FSEM tested with other half of data

In addition to observation of model fit indices, the parameter estimates for the structural portion of the model were observed and interpreted (see Table 6). Each of the hypothesized associations was observed to be of substantial size (i.e., standardized betas ranged from .279 to .728 in absolute value). Small negative effects were observed between perceived neighborhood danger and substance abuse and between the ISF and perceived prosocial behavior. Moderate positive effects were observed between the ISF and both aggression and substance abuse. A moderate to large effect was observed between the ISF and submission.

Table 6
Unstandardized and Standardized Effects – Final Structural Model

		β	<i>SE</i>	<i>p</i>	<i>b</i>
Latent Factor Weights					
Substance abuse	ISF	2.142	.359	<.001	.620
Prosocial bx	ISF	-.640	.101	<.001	-.279
Submission	ISF	1.311	.201	<.001	.728
Aggression	ISF	1			.548
Prosocial bx	Neighb. Dng.	-.612	.076	<.001	-.293
Substance abuse	Neighb. Dng.	-.508	.124	<.001	-.161
Observed Variable Weights					
Q85A	Substance abuse	1			.908
Q85C	Substance abuse	1.008	.015	<.001	.906
Q70D	Aggression	1.060	.067	<.001	.821
Q70B	Aggression	1.177	.062	<.001	.787
Q67G	Submission	1.086	.078	<.001	.626
Q67B	Submission	1.199	.073	<.001	.766
Q67D	Submission	1.224	.080	<.001	.747
Q89A	Substance abuse	.658	.036	<.001	.453
Q87	Substance abuse	1.131	.025	<.001	.752
Q70G	Aggression	1.137	.075	<.001	.774
Q80	Neighb. Dng.	1			.500
Q81A	Neighb. Dng.	1.942	.128	<.001	.636
Q81B	Neighb. Dng.	1.941	.110	<.001	.733
Q81E	Neighb. Dng.	2.020	.124	<.001	.700
Q70A	Aggression	1.209	.060	<.001	.723
Q70C	Aggression	1.141	.064	<.001	.842
Q69	Aggression	1			.659
Q83	Substance abuse	.673	.017	<.001	.738
Q62D	Prosocial bx	1			.663
Q62E	Prosocial bx	1.014	.041	<.001	.763
Q62F	Prosocial bx	1.018	.042	<.001	.746
Q66	Submission	1			.683

Three effects that were not theorized in advance were freely estimated as a result of the modifications to the model. Effects were estimated between perceived neighborhood danger and the ISF, between perceived neighborhood danger and perceived prosocial behavior, and between the residuals for substance abuse and submission. Discussions of the rationales for these effects are found on the following page. The associated standardized effects ranged from .161 to .455 in absolute value. Small negative effects were observed between perceived neighborhood danger and substance abuse, and between perceived neighborhood danger and perceived prosocial behavior. These effects suggest that perceived neighborhood danger is directly and negatively associated with substance abuse and perceived prosocial behavior. A moderate negative effect was observed between the residuals for submission and substance abuse.

The final structural model was tested for fit to the other half of the data resulting from the random split. All fit indices were observed to suggest that the model fit this half of the data very well (see Table 5). The CFI and TLI values were observed at .962 and .956, respectively, and the RMSEA value was observed at .042. In addition, the parameter estimates observed using each half of the data were very similar in magnitude. These results suggest that the modifications did not lead to the over-fitting of the model.

In light of substantive rationale, the substance of the parameter estimates, and the observed indices of fit, the final structural model was accepted as the best reproducer of the relationships between the modeled constructs. While the three effects discussed above were unanticipated by the theoretical model advanced in this study, they are consistent with it, and their specification was supported by substantive rationale as well as statistical considerations. The rationales for these effects are discussed below.

In hindsight it is unsurprising that a direct negative effect was found between perceived prosocial behavior and perceived neighborhood danger. Within the present theoretical framework this effect can be viewed as shared variance between perceived neighborhood danger and perceived prosocial behavior that is unaccounted for by a reliance on implicit cognitive processing. A possible rationale for this effect is derived from game theory. Studies on human strategies have found that for humans cooperating first and ceasing to cooperate when others defect is a stable strategy (i.e., it is effective over time; Charlesworth, 1996; Mealey, 2000). In an environment where individuals rely on implicit cognitive processing and the associated short-term strategies, the payoff for cooperating first would be lower than in a safe environment. In a dangerous environment defecting may yield a greater benefit because one may not live to realize the benefits of cooperation, and because one may not live to realize the negative consequences of defecting. Thus, outside of a reliance on implicit processing among secondary students, a direct negative effect between perceived neighborhood danger and perceived prosocial behavior may represent the lower level of reinforcement for cooperation in such an environment. That is, community norms may not reinforce prosocial behaviors, even among individuals who are not characterized by an ISF.

The negative direct effect between perceived neighborhood danger and substance abuse was initially surprising, but some studies have found positive relationships between SES and some types of substance abuse (e.g., Hanson & Chen, 2007), and in the present sample SES and perceived neighborhood danger were negatively correlated ($r = -.48$, $p < .001$). It may be the case that once the ISF is controlled for, the remaining variance shared by substance abuse and perceived neighborhood danger is related to income, with

less income being associated with less power for purchasing substances, and therefore less substance abuse.

Finally, it is relatively unsurprising that a negative relationship was found between submission and substance abuse. Substance abuse has previously been found to be positively associated with indicators of externalization (Robbins & Bryan, 2004). It may be the case that those low on constructs such as sensation seeking (i.e., high on indicators of internalization) are protected from substance abuse. However, this would contrast with recent evidence that depression potentially mediates the relationship between victimization and substance abuse among females (Luk, Wang, & Simons-Morton, 2010). Alternatively, it may be that substance abuse decreases submissiveness. This study's cross-sectional design could not provide differential support for these possibilities.

Tests of Alternative Models. Three models were tested for fit to the data to determine if an alternative model might fit the data better than the final structural model that included the ISF (see Table 7). The first was the second hypothesized model. This model resulted from the removal of the ISF factor from the final structural model. The latent factor, perceived neighborhood danger, was exogenous, while the other latent factors were endogenous. Parameters were freely estimated between perceived neighborhood danger and each of the endogenous factors. This alternative structural model was over-identified with 201 degrees of freedom and was characterized by a RMSEA value of .050, a CFI value of .948, and a TLI value above .941. All observed fit statistics indicated that the model fit the data substantially worse than the final structural

model (i.e., those discussed and $\Delta\text{BIC} > 400$ & $\Delta\chi^2 > 500$, $p < .001$). This model was therefore rejected in favor of the final structural model.

The second alternative model was the third hypothesized model. This model resulted from the replacement of the ISF with an observed variable representing neuroticism. This variable was created by aggregating nine 5-point ordinal variables measuring frequency of symptoms associated with neuroticism. Examples of the symptoms measured included *feeling low, irritable or bad temper, feeling nervous, and difficulty sleeping*. The scale mean was 17.62, the standard deviation was 9.581, and Cronbach's alpha coefficient was observed at .821. This model was over-identified with 221 degrees of freedom, and was characterized by a RMSEA value greater than .05 (i.e., RMSEA = .078) and CFI and TLI values less than .95 (i.e., CFI = .862, TLI = .842). These fit statistics indicated a much poorer fit to the data relative to the final structural model that included the ISF.

In the third alternative model tested (i.e., fourth hypothesized model) the final structural model was tested with neuroticism specified as endogenous along with substance abuse, aggression, submission, and perceived prosocial behavior, rather than as the factor that linked the study's constructs. This model was over-identified with 219 degrees of freedom and was observed to result in a very good fit to the data. A RMSEA value greater than .05 (i.e., RMSEA = .041) and CFI and TLI values greater than .95 (i.e., CFI = .963, TLI = .958) were observed, suggesting that neuroticism is best modeled as reflective of the ISF instead of in place of it. No areas of strain remained for this model, and it is notable that with the latent factor representing the ISF extracted, no direct paths between neuroticism and the study's other factors were necessary, suggesting that

neuroticism may represent physiological symptoms associated with an ISF. The standardized beta between the ISF and neuroticism was observed at .43, indicating that the ISF subsumed about 18% of the variance in neuroticism. These results suggest that the alternative models supported by the present dataset do not provide a better fitting model than the final structural model including the ISF.

Table 7
Alternative Structural Models

	DF	χ^2	RMSEA	BIC	CFI	TLI
FSEM	198	1047.144***	.040[.038-.042]	1481.249	.968	.962
NOISF	201	1555.949***	.050[.048-.053]	1966.376	.948	.941
NEUR1	221	3900.119***	.079[.077-.081]	4334.225	.862	.842
NEUR2	219	1198.212***	.041[.039-.043]	1648.103	.963	.958

*** $p < .001$. 95% confidence intervals for RSMEA in brackets. FSEM=Final Structural Model; NOISF=No ISF factor; NEUR1=Neuroticism in place of ISF; NEUR2=Neuroticism as reflective of ISF

Multi-Group Tests. The final structural model was tested for fit to the data for each sex. For males the model (see Table 8 for fit indices and Appendix C for the model) was over-identified with 198 degrees of freedom and was characterized by an RMSEA value below .05 (i.e., RMSEA = .045), a CFI value of above .95 (i.e., CFI = .965), and a TLI value above .95 (i.e., TLI = .969). All observed fit statistics indicated that the model fit the data very well. All unstandardized betas, variances, and covariances were statistically significant ($ps < .01$) except for the error covariance between the indicator for *frequency of sexual jokes made about me* and *frequency of rumors spread about me* (i.e., err21 - err23). This result suggested that the source of the covariation between these two indicators may have been limited to females. Observation of the modification indices and standardized residuals suggested that no areas of strain remained for the final structural model, and this model was accepted as the model for males.

For females, the model resulted in an error message indicating that negative variances had been found. Bootstrapping was disabled in an attempt to identify the source of the problem. Negative variances were observed for the residuals associated with substance abuse and submission, and a standardized beta of .99 was observed for the effect between these residuals. These results were interpreted as indication that the residual covariance between submission and substance abuse was a misspecification in the model for females. This interpretation is consistent with the suggested rationale for this effect, which was inconsistent with research among females. The parameter was removed, bootstrapping was enabled, and the model was then over-identified with 199 degrees of freedom. Overall, the model appeared to fit the data reasonably well (i.e., CFI = .954, TLI = .947, and RMSEA = .041). One area of substantial strain appeared to remain for the model (standardized residual > 2 and MI > 100). The relationship between the item representing making sexual jokes about others and being the victim of such jokes was not adequately reproduced by the model. The model was re-specified to freely estimate an error covariance for these items.

The re-specified model for females (see Table 8 for fit indices and Appendix D for the model) was over-identified with 198 degrees of freedom and was observed to fit the data very well (i.e., CFI = .960, TLI = .954, and RMSEA = .038). All variances and covariances were statistically significant ($p < .001$). One unstandardized beta was not statistically significant (i.e., perceived neighborhood danger-substance abuse). The added covariance between the two sexual jokes items was statistically significant ($p < .001$), and the related correlation was observed at .20. A study discussed in the review of the literature may explain this effect. In the review evidence was presented that indicated that

the vast majority of bullying is intrasexual (i.e., Gallup et al., 2009). Among females, those who are more attractive appear to be victimized more frequently (see also Cunningham et al., 2011). The evolutionary explanation that was introduced followed the logic that females harass or derogate attractive females to compete with them more successfully. Among females, derogating and inflicting stress on competitors may confer a reproductive advantage through effects on status and fertility (Mealey, 2000). This harassment may be heightened among higher status, more attractive females, explaining the effect detected. No further areas of substantial strain were observed for this model, and it was accepted as the best reproducer of the relationships among females.

Table 8
Structural Models for Males and Females

	DF	χ^2	RMSEA	BIC	CFI	TLI
MALE	198	1219.855***	.045[.042-.047]	1651.739	.965	.969
FEML	199	1125.842***	.041[.039-.043]	1554.151	.954	.947
FEML2	198	1000.841***	.038[.036-.041]	1437.082	.960	.954

***p<.001. MALE=FSEM tested with males only; FEML=FSEM-cov (res2-res3) and with females only; FSEM2=FSEM+cov (err9-err21)

A test of multi-group invariance was carried out for the structural portion of the final model (see Table 9). The multi-group model was over-identified with 399 degrees of freedom and was observed to fit the data very well (i.e., CFI = .963, TLI = .957, and RMSEA = .029). All parameters were observed to be statistically significant except for those that were non-significant in the male- and female-only models. χ^2 tests were conducted (.05 level) to determine whether constraining effects to equality across groups resulted in statistically significant decreases in model fit to the data. The error covariance added between the two sexual jokes items was constrained to zero for the male group because it was unique to females. The residual covariance between substance abuse and submission was set to zero for the female group because it was unique to males. The

effects between perceived neighborhood danger and perceived prosocial behavior, between the ISF and aggression, and between the ISF and submission, were observed to be invariant across the sexes. The effects between perceived neighborhood danger and substance abuse, between the ISF and substance abuse, between the ISF and perceived prosocial behavior, and between perceived neighborhood danger and the ISF varied across the groups. These varying effects were observed to be smaller for females.

Table 9
Multi-Group Tests of Invariance for Structural Portion of the Final Model

	DF	χ^2	RMSEA	AIC	CFI	TLI
INVT1	396	2220.701***	.029[.028-.031]	2440.701	.963	.957
INVT2	397	2222.919***	.029[.028-.031]	2440.919	.963	.957
INVT3	398	2232.781***	.029[.028-.031]	2448.781	.963	.957
INVT4	398	2264.063***	.030[.028-.031]	2480.063	.962	.956
INVT5	398	2223.375***	.029[.028-.030]	2439.375	.963	.957
INVT6	399	2231.803***	.029[.028-.030]	2445.803	.963	.957
INVT7	399	2223.467***	.029[.028-.030]	2437.467	.963	.957
INVT8	401	2232.468***	.029[.028-.030]	2444.468	.963	.957

***p<.001. 95% confidence intervals for RSMEA in brackets. INVT1=Final model tested with multi-groups (both sexes); INVT2=INVT1 + eq. constraint (neighborhood danger-prosocial behavior); INVT3=INVT2 + eq. constraint (neighborhood danger-substance abuse); INVT4 = INVT2 + eq. constraint (neighborhood danger-ISF); INVT5=INVT2 + eq. constraint (ISF-aggression); INVT6=INVT5 + eq. constraint (ISF-substance abuse); INVT7=INVT5 + eq. constraint (ISF-submission); INVT8=INVT7 + eq. constraint (ISF-prosocial bx)

These results suggested that the effect between perceived neighborhood danger and the ISF was less important for females. This is consistent with the predictions of evolutionary theory, which would posit that females stand to benefit less from responding to harsh/unpredictable environments with short-term strategies (Buss, 2007; MacDonald, 1995; Mealey, 2000). This is due to the greater stability of female investment required to successfully reproduce (Mealey, 2000). In support of this interpretation, the variance for perceived neighborhood danger was observed to be approximately equal across the sexes, while the variance for the ISF was more than twice as large for males than females

(female $var = .192$ & male $var = .474$). The effect between perceived neighborhood danger and substance abuse became non-significant for females. One possible explanation for this finding is that adolescent males may procure substances of abuse for adolescent females. If the explanation of the negative effect observed for the whole sample is correct, money may be much less of an obstacle for females wishing to abuse substances. It is common knowledge that young adult males frequently purchase females drinks at bars, and similar behavior may generalize to secondary students. The effect between perceived neighborhood danger and perceived prosocial behavior was equally important across the sexes, and this may be interpreted as suggesting that the effects of environmental norms on perceptions of prosocial behavior are sexually invariant. It may not be beneficial to attempt to cooperate among uncooperative peers, whatever one's sex, and antisocial environments may be similarly perceived by each sex.

Interestingly, the effects between the ISF and both aggression and submission were invariant across the groups. This result was inconsistent with the predictions advanced in the literature review. At first glance these results seem inconsistent with group mean differences on these constructs; but they are not, however. Indeed, t-tests revealed that in this sample males scored significantly higher on aggression, while females scored significantly higher on submission ($p < .001$). These results appear to suggest that although levels of aggression and submission vary by sex, the power of the ISF to explain variance in these constructs does not.

The association between the ISF and perceived prosocial behavior was greater among males than females. It could be the case that female cognition is less dichotomized than male cognition, leading to a more integrated combination of implicit evaluation and

behavioral activation with explicit inhibition and caution. Explicit processes may be less easily inhibited among females. This would be consistent with the higher levels of conscientiousness observed among females (MacDonald, 1995), along with their greater focus on protecting offspring (Buss, 2007; Mealey, 2000).

Finally, the positive association between the ISF and substance abuse was greater in magnitude for males. From an evolutionary perspective, it could be supposed that males experience substance abuse as more of a resource than do females, and their greater evolved predisposition to search the environment and control resources may lend itself to a tendency to abuse substances at higher levels in association with an ISF. Substance abuse may fit better into the male behavioral repertoire for surviving harsh or unpredictable conditions.

CHAPTER V

Discussion

This study synthesized life history theory and dual process models of cognition to produce an adaptive and cognitive framework for explaining substance abuse. An immediate survival focus was proposed as a construct representing reliance on implicit cognitive processing for the purpose quick evaluation and short-term strategy use in dangerous or unpredictable environments. The ISF was suggested as contributing to false positives in the detection of resources and threats critical to survival (i.e., irrational beliefs), and thus vulnerability to substance abuse.

Theoretical Contributions of the ISF

Life History Theory and Dual Process Models. The present theoretical synthesis represents an original contribution to both the literature on dual process models, as well as the literature on life history theory. To dual process models, an ISF supplies a theory of how genes and the environment may interact to influence cognitive processing, which responds adaptively to facilitate survival and reproduction. An ISF also introduces the possibility that implicit processes may be generally relied upon as a result of particular genes and environments. While research on the interface between implicit cognition and substance abuse has produced explanations of how implicit processes maintain addiction (e.g., Munafò & Albery, 2006), this synthesis provides the addition of a theory suggesting how implicit processes operate to produce risk for addiction.

To life history theory, an ISF supplies a cognitive mechanism that may support the facultative use of short-term reproductive strategies. An ISF provides a framework for understanding the role of cognition in the assessment of environmental conditions, the subsequent adoption of survival and reproductive strategies, and the implicit or explicit selection of a niche in which chosen strategies are likely to be successful. This theoretical synthesis has developed the perspective that substance abuse represents both the strategies adopted, as well as the niche selected, by some individuals attempting short-term survival and reproduction.

Risk for Substance Abuse and Cognitive Bias. As suggested in the introduction, the ISF may link the risk factors for substance abuse with the cognitive biases (for substance related stimuli) characteristic of those high on substance abuse. This synthesis introduced the notion that cognition responds to indicators of low survival probability (e.g., low parental investment or attachment, low environmental predictability, neighborhood danger, etc.) by becoming more automatic in support of short-term survival and quicker reproduction. This ISF is characterized by a relatively high error rate in the evaluation of possible resources and threats critical to survival, as accuracy is traded for evaluative speed in the interest of short-term survival and reproduction. In this context substances are quickly evaluated and tagged as either resources critical to survival or as the escape of critical threats. Reflection upon substance abuse is inhibited by an ISF and habit formation is initiated. Due to an ISF, substance abuse becomes quickly controlled by the habit system, becoming an automatically initiated behavior with a fixed value (see Redish, Jensen, and Johnson, 2008). At this point cognitive bias for substance related stimuli is well-established, and substance abusers find great difficulty in inhibiting

behaviors associated with exposure to substance abuse related cues (McCusker, 2006; Munafò & Albery, 2006).

The discussion above sheds light on several aspects of substance abuse that are little understood. First, an ISF provides an explanation of the dichotomous thinking often observed and reported by substance abuse counselors (see Beck et al., 1993). The ISF implies that substance abusers are using implicit processes to quickly identify critical resources and threats. As a result, many of their evaluations could be expected produce black-or-white beliefs, or beliefs that objects are critically good or bad (i.e., absolutely good or bad). An ISF, supported by implicit processes, also provides insight into the curious tendency of substance abusers to be both impulsive and compulsive. At the same time that substance abusers are pursuing critical resources or avoiding critical threats, they can be observed to make very quick or impulsive decisions. If impulsivity is a behavioral trait associated with a reliance on quick and automatic processing, and compulsivity represents the pursuit or avoidance of critical resources or threats identified by such processing, then the umbrella of the ISF covers both traits.

The Emergent Addictive Phenotype. An ISF provides the literature on substance abuse with a possible answer to the question: How does the addictive phenotype emerge from the interaction of genes with the environment? The ISF also helps to explain the low success rates widely observed in the treatment of chemical dependency. Adopting an evolutionary meta-theoretical lens, substance abuse is not viewed as a disease in the same sense as diabetes. It is seen as a strategy adopted by the human phenotype, which has emerged to interact with the environment and reproduce its genetic material. It is a strategy for survival and reproduction. Consistent with this

argument is the return to controlled use among those with substance use disorders (McCusker, 2006), along with the phenomenon of replacement addiction (i.e., drugs are replaced with other stimuli; see Sussman & Black, 2008). For substance abusers, alternative strategies (i.e., cognitions or outward behaviors) are available for adoption, where diabetes is characterized by no comparable degree of plasticity.

In harsh and unpredictable environments humans have had little time to reproduce. It follows that they have had scarce time to learn the most effective strategies for harvesting energy (i.e., food), to select the highest quality mates attainable, to accumulate and control resources for purchasing the services of others, to provision and train offspring for competition in a social hierarchy, and to maintain coalitions devoted to the common good of their members. Our ancestors that faced a high probability of death took what food they could get, mated where possible, kept friends when friendship immediately benefited them, and hoped that some of their offspring would be lucky enough to survive. Those that were too slow to reproduce in such contexts are not our ancestors.

Within the context described above, substances are experienced as the acquisition of resources or the escape of threat, and this representation of substances may correspond to reality to the extent that it is useful to individuals in this context. That is, the notion that substances are of illusory benefit may be one that is limited to those employing slow LHS in safe or predictable environments, because substance abuse doesn't facilitate such long-term attempts survival and reproduction. Substances may be considered *real* resources for survival and reproduction by those attempting short-term reproduction because they may actually facilitate such reproductive attempts. This is reminiscent of the

position advanced by the American pragmatists William James and John Dewey, namely that beliefs may be true to the degree that they are useful (Moore, 1961). The present theoretical framework provides us with a perspective for understanding what we are likely to believe is true, suggesting that our truths are rooted in the LHS we employ. Particular genes and environments may interact to produce a phenotype characterized by an ISF, and individuals so characterized may be susceptible to substance abuse, along with related worldviews and conceptions of truth.

Treatment and Prevention. Today many humans find themselves in relatively safe environments with plenty of resources. In such environments an ISF may present an obstacle to the health and longevity that is available to individuals. Inhibition of the ISF and facilitation of the use of slow LHS seems warranted in such contexts. From the perspective advanced here, treatment practitioners would not simply provide the chemically dependent with a medical treatment. They would provide a change in worldview. In treatment, those with substance use disorders are confronted with the challenges of (1) letting go of (i.e., reevaluating) critical resource and threats, (2) of giving up working strategies for others that they have not tested, and (3) of succeeding at 1 and 2 in the face of the experience (implicit or explicit) that long-term survival is of low probability.

An ISF provides insight into the resistance of substance abusers to information suggesting they *have a problem*. Substance abusers may be on track for short-term survival and reproduction, and because they may have the experience of acquiring critical resources and avoiding critical threats, they may be experiencing (explicitly or implicitly) success in a reproductive attempt. Informing substance abusers of the high probability of

death inherent in their strategy does little to cause panic because the ISF and associated strategies are selected to succeed in the face of the *correlates of death* (phrase adapted from Chisholm, 1993). Resistance to change among substance abusers stems not only from habit, but also from fear of relinquishing a potentially successful strategy in favor of strategy that is untested. This fear is enhanced by the effect of past experiences with environmental harshness and unpredictability, which indicate the probable failure of slow LHS.

An ISF may contribute to substance abuse through support of a tendency to rely on implicit cognitive processing. This reliance may support quick evaluations that are more likely to result in the identification of substance abuse as an effective tactic for acquisition of resources and escape of threats. Several implications for treatment and prevention interventions may follow. First, the synthesis advanced here could be used to inform cognitive behavioral therapies. Presently cognitive behavioral therapies do little to address the interplay between cognition and general environmental conditions, and do not explicitly focus on the relationships of beliefs and outward behaviors with survival and reproduction. An ISF provides a perspective for considering the ecology from which cognitions emerge, along with the goals at which beliefs and outward behaviors are aimed.

The results of this study are consistent with the notion that substance abusers are generally relying on implicit processes to support short-term, risky strategies for survival and reproduction. Therapist and preventionists may recognize this ISF in individuals who make quick decisions, think in black-and-white, believe they absolutely *must* pursue particular goals, and use aggression and submission instead of assertive communication.

These individuals might be identified as *at risk*, or treated if problems such as substance abuse have developed. Using a life history perspective the ISF might be inhibited through reevaluation of stimuli identified as resources and threats critical to survival. In addition, this synthesis might be used to train individuals to recognize their use of implicit cognitive processes, enabling them to inhibit such processes on their own. This represents a top-down approach to facilitating the use of slow LHS, such that the implicit cognitive processes maintaining fast LHS are inhibited.

Therapists and preventionists could also intervene upon a suite of life history traits, such that in substance abusers the ISF and fast LHS are inhibited from the bottom-up. First, to employ slow LHS individuals need to have the experience that postponing reproduction is beneficial. Therefore, strategies for increasing individuals' experience of the value of future reproduction would be suggested. These could include strategies for increasing experience of future earning potential, increasing social facility and perceived mate quality, and developing long-term plans that are perceived to be realistic, among others. Second, interventions could educate individuals about LHS and the relationships between behavioral strategies. Within this framework treatment and prevention interventions could explicitly address the particular survival and reproductive strategies employed by individuals. Are they searching for short-term mates, manipulating others, and pursuing thrilling experiences? Slow LHS would be increased by replacing these strategies with the use of sub-strategies comprising a long-term approach to survival and reproduction.

Results and Future Directions

As mentioned, the results of this study are consistent with the existence of an ISF. A factor was extracted from constructs known to rely on implicit cognitive processing, and this construct was positively associated with both substance abuse and neighborhood danger, as predicted. This construct was negatively associated with prosocial behavior, which is known to operate to the relative exclusion of implicit cognitive processes. Some of the effects between the ISF and the study's other constructs were invariant across the sexes, while others were not. The ISF was more highly associated with neighborhood danger, substance abuse, and prosocial behavior among males, but was important to the constructs for both sexes. The first of these results was predicted using the theoretical framework advanced here. The latter two were consistent with the present framework, but were not anticipated. For the sample as a whole, the ISF accounted for 38% of the variance in substance abuse, therefore representing an important construct in efforts to learn about, treat, and prevent substance abuse.

Limitations. Though these results are consistent with the existence of the ISF, along with the initial predictions produced by the framework advanced here, several limitations apply. First, no direct measure of cognitive processing was available, limiting the confidence appropriate to the inference that the ISF is supported by implicit cognitive processes. Second, proxy indicators of submission were used. Items loading on both submission and aggression were viewed as misspecifications, and were eliminated in an attempt to secure a measure of only submissive responses to social threat. However, some uncertainty surrounds the validity of the submission construct. Finally, generalization of

these results is constrained by the sample used, and should be limited to 9th and 10th grade secondary students in the United States.

Future Directions. Several limitations to the external validity of this study's results have been identified. Future research can take steps to overcome these limitations. First, future research could test for the existence of the ISF in populations of 11th and 12th grade secondary students, adults, and possibly middle school students.

Second, future research could implement a measure of implicit cognitive processing or at least a questionnaire that reliably measures the cognitive products of such processing. The former may be accomplished using ecological momentary assessment to evaluate real world evaluative speed and dichotomization associated with critical resources and threats. The latter may include measures of dichotomous thinking, perfectionism, evaluative extremity, or possibly attitude certainty. These constructs may represent false positives in the detection of resources or threats critical to survival.

Finally, future research can further assess the ability of ISF to explain and predict substance abuse and other high risk behaviors (e.g., longitudinally), and eventually test the ability of the framework advanced here to improve counseling interventions. In these pursuits researchers should be sensitive to possible sex differences related to both the ISF and LHS and the effect of environmental conditions on the conceptualization of problem behaviors.

REFERENCES

- Adams, J. (2009). The role of time perspective in smoking cessation amongst older English adults. *Health Psychology, 28*, 529-534.
- Allen, T. J., Moeller, F. G., Rhoades, H. M., & Cherek, D. R. (1998). Impulsivity and history of drug dependence. *Drug and Alcohol Dependence, 50*, 137-145.
- American Psychiatric Association. (2000). *Diagnostic and statistical manual of mental disorders, fourth edition, text revision*. Washington, DC: Author.
- Batson, C. D. (1995). Prosocial motivation: Why do we help others? In A. Tesser (Ed.), *Advanced Social Psychology* (pp. 333-381). New York, NY: McGraw-Hill, Inc.
- Beck, A. T., Wright, F. D., Newman, C. F., & Liese, B. S. (1993). *Cognitive therapy of substance abuse*. New York, NY: The Guilford Press.
- Bentler, P. M., & Chou, C. P. (1987). Practical issues in structural modeling. *Sociological Methods and Research, 16*, 78-117.
- Berridge, K. C. (2003). Comparing the emotional brains of humans and other animals. In R. J. Davidson & Scherer (Eds.), *Handbook of affective sciences* (pp. 25-51). New York: Oxford University Press.
- Bogg, T., & Roberts B. (2004). Conscientiousness and health-related behaviors: A meta-analysis of the leading behavioral contributors to mortality. *Psychol Bull, 130*, 887 - 919.
- Broderick, P. C., & Blewitt, P. B. (2006). *The life span: Human development for helping professionals, second edition*. Upper Saddle River, NJ: Pearson Education, Inc.
- Brown, T. A. (2006). *Confirmatory factor analysis for applied research*. The Guilford Press, New York: NY.
- Browne, M. W., & Cudeck, R. (1993). Single sample cross-validation indices for covariance structures. *Multivariate Behavioral Research, 24*, 445-455.
- Buss, D. M. (1991). Evolutionary personality psychology. *Annual Review of Psychology, 42*, 459.

- Byrne, B. M. (2001). *Structural equation modeling with AMOS: Basic concepts, applications, and programming*. Mahwah, NJ: Lawrence Erlbaum Associates, Inc.
- The National Center on Addiction and Substance Abuse (CASA). (2005). *Shoveling up II: The impact of substance abuse on federal, state and local budgets*. New York, NY: Author.
- Charlesworth, W. R. (1996). Co-operation and competition: Contributions to an evolutionary and developmental model. *International Journal of Behavioral Development, 19*, 25-39.
- Chisholm, J. S. (1993). Death, hope, and sex: Life-history theory and the development of reproductive strategies. *Current Anthropology, 34*, 1-24.
- Crick, N. R. (1996). The role of overt aggression, relational aggression, and prosocial behavior in the prediction of children's future adjustment. *Child Development, 67*, 2317-2327.
- Crick, N. R., & Bigbee, M. A. (1998). Relational and overt forms of peer victimization: A multiinformant approach. *Journal of Consulting & Clinical Psychology, 66*(2), 337-347.
- Cronbach, L. J. (1951). Coefficient alpha and the internal structure of tests. *Psychometrika, 16*, 297-334.
- Cunningham, N. J., Taylor, M. P., Whitten, M., DeLaney, N. & Eder, K. (2011). *The relationship between self perception of physical attractiveness and sexual bullying*. Manuscript submitted for review (copy on file with first author).
- Cunningham, W. A., Raye, C. L., & Johnson, M. K. (2004). Implicit and explicit evaluation: fMRI correlates of valence, emotional intensity, and control in the processing of attitudes. *Journal of Cognitive Neuroscience, 16*, 1717-1729.
- Cunningham, W. A., & Zelazo, P. D. (2007). Attitudes and evaluations: A social cognitive neuroscience perspective. *Trends in Cognitive Sciences, 11*, 97-104.
- Davidson, R. J. (2004). What does the prefrontal cortex "do" in affect? Perspectives on frontal EEG asymmetry research. *Biological Psychology, 67*, 219-233.
- Edmunds, G. (1977). Extraversion, neuroticism and different aspects of self-reported aggression. *Journal of Personality Assessment, 41*, 66-70.

- Ellis, B. J., Figueredo, A. J., Brumbach, B. H., & Schlomer, G. L. (2009). Fundamental dimensions of environmental risk: The impact of harsh versus unpredictable environments on the evolution and development of life history strategies. *Hum Nat*, *20*, 204-268.
- Field, M. (2006). Attentional biases in drug abuse and addiction: Cognitive mechanisms, causes, consequences, and implications. In M. Munafò & I. P. Albery (Eds.), *Cognition + Addiction* (pp. 31-72). Great Clarendon Street, Oxford: Oxford University Press.
- Figueredo, A. J., Vásquez, G., Brumbach, B., Sefcek, J. A., Kirsner, B. R., & Jacobs, W. J. (2005). The K-factor: Individual differences in life history strategy. *Personality and Individual Differences*, *39*, 1349-1360.
- Figueredo, A. J., Vásquez, G., Brumbach, B., Schneider, S. M., Sefcek, J. A., Tal, I. R., Hill, D., Wenner, C. J., & Jacobs, W. J. (2006). Consilience and life history theory: From genes to brain to reproductive strategy. *Developmental Review*, *26*, 243-275.
- Fox, C. L., & Boulton, M. J. (2005). The social skills problems of victims of bullying: Self, peer and teacher perceptions. *British Journal of Educational Psychology*, *75*, 313-328.
- Fromme, K., Stroot, E., & Kaplan, D. (1993). Comprehensive effects of alcohol: Development and psychometric assessment of a new expectancy questionnaire. *Psychological Assessment*, *5*(1), 19-26.
- Gallup, A. C., O'Brien, D. T., White, D. D., & Wilson, D. S. (2009). Peer victimization in adolescence has different effects on the sexual behavior of male and female college students. *Personality and Individual Differences*, *46*, 611-615.
- Geary, D. C., & Flinn, M. V. (2001). Evolution of human parental behavior and the human family. *Parenting: Science & Practice*, *1*, 5.
- Gilbert, P. (1998). The evolved basis and adaptive functions of cognitive distortions. *British Journal of Medical Psychology* *71*, 447-463.
- Goldman, M. S., Darkes, J., & Brandon, K. O. (2006). From DNA to conscious thought: The influence of anticipatory processes on human alcohol consumption. In M. Munafò & I. P. Albery (Eds.), *Cognition + Addiction* (pp. 146-184). Great Clarendon Street, Oxford: Oxford University Press.
- Goldman, M. S., & Rather, B. C. (1993). *Substance use disorders: Cognitive models and architecture*. San Diego, CA: Academic Press.

- Grant, B. F., Stinson, F. S., Dawson, D. A., Chou, S. P., Dufour, M. C., Compton, W., Pickering, R. P., & Kaplan, K. (2004). Prevalence and co-occurrence of substance use disorders and independent mood and anxiety disorders: Results from the National Epidemiologic Survey on Alcohol and Related Conditions. *Archives of General Psychiatry*, *61*, 807-816.
- Griffith, J. W., Zinbarg, R. E., Craske, M. G., Mineka, S., Rose, R. D., Waters, A. M., & Sutton, J. M. (2009). Neuroticism as a common dimension in the internalizing disorders. *Psychological Medicine, First View*, 1-12.
- Hamilton, W. D. (1964). The genetic evolution of social behavior. I, II. *J. Theor. Biol.*, *7*, 1-52.
- Hanson, M. D., & Chen E. (2007). Socioeconomic status and substance use behaviors in adolescents. *Journal of Health Psychology*, *12*(1), 32-35.
- Hawker, D. S., & Boulton, M. J. (2000). Twenty years' research on peer victimization and psychosocial maladjustment: A meta-analytic review of cross-sectional studies. *Journal of Child Psychology and Psychiatry*, *41*, 441-455.
- Hawley, P. H. (2003). Prosocial and coercive configurations of resource control in early adolescence: A case for the well-adapted Machiavellian. *Merrill-Palmer Quarterly*, *49*, 279-309.
- Hill, E. M., Ross, L.T., & Low, B.S. (1997). The role of future unpredictability in human risk-taking. *Human Nature*, *8*, 287-325.
- Higgins, E. T., Shah, J., & Friedman, R. (1997). Emotional responses to goal attainment: Strength of regulatory focus as moderator. *Journal of Personality & Social Psychology*, *72*, 515-525.
- Higgins, E. T. & Spiegel, S. (2004). Promotion and prevention strategies for self-regulation: A motivated cognition perspective. In R. F. Baumeister & K. D. Vohs (Eds.), *The Handbook of Self-Regulation* (pp. 171-187). New York, NY: The Guilford Press.
- Hodges, E. V. E., & Perry, D. G. (1999). Personal and interpersonal antecedents and consequences of victimization by peers. *Journal of Personality and Social Psychology*, *76*, 677-685.
- Honk, J., Schutter, D. J. L., Hermans, E. J., & Putnam, P. (2004). Testosterone, cortisol, dominance, and submission: Biologically prepared motivation, no psychological mechanisms involved. *Behavioral and Brain Sciences*, *27*, 160-160.

- Hu, L., & Bentler, P. M. (1999). Cutoff criteria for fit indexes in covariance structure analysis: Conventional criteria versus new alternatives. *Structural Equation Modeling, 6*, 1–55.
- Hudes, E., & Neilands, T. (2007). *Handling missing data* [PowerPoint slides]. Retrieved from www.caps.ucsf.edu/CAPS/about/.../Missing_Data_20070316_ESH.ppt
- Judge, T.A., & Kammeyer-Mueller, J.D. (2007). Personality and career success, In Gunz, H. & Peiperl, M. (Eds.), *Handbook of Career Studies*. London: Sage.
- Kendler, K. S., Prescott, C. A., Myers, J., & Neale, M. C. (2003). The structure of genetic and environmental risk factors for common psychiatric and substance use disorders in men and women. *Archives of General Psychiatry, 60*, 929-937.
- Kilpatrick, D. G., Acierno, R., Saunders, B., Resnick, H. S., Best, C. L., & Schnurr, P. P. (2000). Risk factors for adolescent substance abuse and dependence: Data from a national sample. *Journal of Consulting & Clinical Psychology, 68*(1), 19-30.
- Klinger, E., & Cox, W. M. (2004). Motivation and the theory of current concerns. In W. M. Cox and E. Klinger (Eds.), *Handbook of motivational counseling: Concepts, approaches, and assessment* (pp. 3-29). Chichester, UK: Wiley.
- Kruger, D. J., Reischl, T. & Zimmerman, M. A. (2008). Time perspective as a mechanism for functional developmental adaptation. *Journal of Social, Evolutionary, and Cultural Psychology, 2*(1), 1-22.
- Laub, J. H., & Vaillant, G. E. (2000). Delinquency and mortality: A 50-year follow-up study of 1,000 delinquent and nondelinquent boys. *American Journal of Psychiatry, 157*(1), 96-102.
- Lemerise, E. A., & Dodge, K. A. (1993). The development of anger and hostile intentions, In M. Lewis & J. M. Haviland-Jones (Eds.), *Handbook of emotions* (pp. 537-546). New York: Guilford Press.
- Lieberman, M. D. (2007). The X- and C-systems: The neural basis of automatic and controlled social cognition. In E. Harmon-Jones & P. Winkielman (Eds.), *Social Neuroscience: Integrating Biological and Psychological Explanations of Social Behavior* (pp. 290-315). New York, NY: The Guilford Press.
- Luk, J. W., Wang, J., & Simons-Morton, B. G. (2010) Bullying, victimization and substance use among U.S. adolescents: Mediation by depression. *Prevention Science, 11*, 355-359.
- MacDonald, K. (1995). Evolution, the five-factor model, and levels of personality. *Journal of Personality, 63*, 525-567.

- Margaron, H. (2004). Pleasure: From onthogenesis to addiction. *Substance Use & Misuse*, 39, 1423-1434.
- McCusker, C. (2001). Cognitive biases and addiction: an evolution in theory and method. *Addiction*, 96, 47-56.
- McCusker, C. (2006). Towards understanding loss of control: An automatic network theory of addictive behaviours. In M. Munafó & I. P. Albery (Eds.), *Cognition + Addiction* (pp. 117-146). Great Clarendon Street, Oxford: Oxford University Press.
- Mealey, L. (2000). *Sex differences: Developmental and evolutionary strategies*. San Diego, CA: Academic Press.
- Mokdad, A. H., Marks, J. S., Stroup, D. F., & Gerberding, J. L. (2004). Actual causes of death in the United States, 2000. *Journal of the American Medical Association*, 291, 10.
- Moore, E. C. (1961) *American pragmatism: Pierce, James, and Dewey*. New York: Columbia University Press.
- Munafó, M. & Albery, I. P. (2006). *Cognition + Addiction*. Great Clarendon Street, Oxford: Oxford University Press.
- Nation, M., & Helfinger, C. A. (2006). Risk factors for serious alcohol and drug use: The role of psychosocial variables in predicting the frequency of substance use among adolescents. *American Journal of Drug & Alcohol Abuse*, 32, 415-433.
- Nesse, R. M. (1994). An evolutionary perspective on substance abuse. *Ethology & Sociobiology*, 15, 339-348.
- Nesse, R. M., & Williams, G. C. (1996). *Why We Get Sick: The New Science of Darwinian Medicine*. New York, NY: Times Books.
- Nobile, M., Giorda, R., Marino, C., Carlet, O., Pastore, V., Vanzin, L., Bellina, M., Molteni, M., & Battaglia, M. (2007). Socioeconomic status mediates the genetic contribution of the dopamine receptor D4 and serotonin transporter linked promoter region repeat polymorphisms to externalization in preadolescence. *Development and Psychopathology*, 19, 1147.
- Office of National Drug Control Policy (ONDCP). (2004). *The economic costs of drug abuse in the United States, 1992-2002*. Washington, DC: Executive Office of the President (Publication No. 207303).

- Parkhurst, J. T., & Asher, S. R. (1992). Peer rejection in middle school: Subgroup differences in behavior, loneliness, and interpersonal concerns. *Developmental Psychology March*, 28(2), 231-241.
- Penner, L. A., Dovidio, J. F., Piliavin, J. A., & Schroeder, D. A. (2005). Prosocial behavior: Multilevel perspectives. *Annu. Rev. Psychol.*, 56, 14.1-14.28.
- Perry, D. G., Kusel, S. J., & Perry, L. C. (1988). Victims of peer aggression. *Developmental Psychology*, 24, 807-814.
- Peters Jr., R. J., Tortolero, S. R., Johnson, R. J., Addy, R. C., Markham, C. M., Escobar-Chaves, S. L., Lewis, H., Yacoubian Jr., & George, S. P. (2005). The relationship between future orientation and street substance use among Texas alternative school students. *American Journal on Addictions*, 14, 478-485.
- Petry, N. M., Bickel, W. K., & Arnett, M. (1998). Shortened time horizons and insensitivity to future consequences in heroin addicts. *Addiction*, 93, 729-738.
- Pohlmann, J. T. (2004). Use and interpretation of factor analysis in *The Journal of Educational Research: 1992–2002*. *The Journal of Educational Research*, 98, 14–23.
- Putman, P., Hermans, E., & van Honk, J. (2004). Selective attention to threatening faces in an emotional Stroop task: It's BAS, not BIS. *Emotion*, 4, 305-311.
- Quinlan, R. J. (2007). Human parental effort and environmental risk. *Proceedings of the Royal Society- Series B*, 274, 121-125.
- Raftery, A. E. (1995). Bayesian model selection in social research. *Sociological Methodology*, 25, 111-163. Retrieved from <http://www.jstor.org/stable/271063?origin=JSTOR-pdf>
- Redish, A., Jensen, S., & Johnson, A. (2008). Addiction as vulnerabilities in the decision process. *Behavioral and Brain Sciences*, 31, 461-470.
- Robbins, R. N., & Bryan, A. (2004). Relationships between future orientation, impulsive sensation seeking, and risk behavior among adjudicated adolescents. *Journal of Adolescent Research*, 19, 428-445.
- Roberts, B. W., Chernyshenko, O. S., Stark, S., & Goldberg, L. R. (2005). The structure of conscientiousness: An empirical investigation based on seven major personality questionnaires. *Personnel Psychology*, 58, 103-139.
- Rose-Krasnor, L. (1997). The nature of social competence: A theoretical review. *Social Development*, 6, 111-135.

- Rubin, K. H., Hymel, S., & Mills, R. S. (1989). Sociability and social withdrawal in childhood: Stability and outcomes. *Journal of Personality*, *57*, 237-255.
- Rushton, J. P. (1985). Differential K theory: The sociobiology of individual and group differences. *Personality and Individual Differences*, *6*, 441-452.
- Rushton, J. P., Bons, T. A., & Hur, Y. (2008). The genetics and evolution of the general factor of personality. *Journal of Research in Personality*, *42*, 1173-1185.
- Schafer, J. L. (1999). *NORM: Multiple imputation of incomplete multivariate data under a normal model, version 2*. Software for Windows 95/98/NT, available from <http://www.stat.psu.edu/~jls/misoftwa.html>.
- Seibert, S. E., & Kraimer, M. L. (2001). The five-factor model of personality and career success. *Journal of Vocational Behavior*, *58*(1), 1-21.
- Shah, J., & Higgins, E. T. (1997). Expectancy x value effects: Regulatory focus as determinant of magnitude and direction. *Journal of Personality & Social Psychology*, *73*, 447-458.
- Sharpe, J. P., & Desai, S. (2001). The revised neo personality inventory and the MMPI-2 psychopathology five in the prediction of aggression. *Personality and Individual Differences*, *31*, 505-518.
- Stacy, A. W., & Wiers, R. W. (2006). An implicit cognition, associative memory framework for addiction. In M. Munafò & I. P. Albery (Eds.), *Cognition + Addiction* (pp. 31-72). Great Clarendon Street, Oxford: Oxford University Press.
- Stoel, R. D., Geus, E. J., & Boomsa, D. I. (2006). Genetic analysis of sensation seeking with an extended twin design. *Behavior Genetics*, *36*, 229-237.
- Stone, V. E. (2007). An evolutionary perspective on domain specificity in social intelligence. In E. Harmon-Jones & P. Winkielman (Eds.), *Social Neuroscience: Integrating Biological and Psychological Explanations of Social Behavior* (pp. 316-349). New York, NY: The Guilford Press.
- Sussman, S., Black, D. S. (2008). Substitute addiction: a concern for researchers and practitioners. *Journal of Drug Education* *38*(2), 167-180.
- Terracciano, A., Lockenhoff, C., Crum, R., Bienvenu, O. J., & Costa, P. (2008). Five-factor model personality profiles of drug users. *BMC Psychiatry*, *8*(1), 22.
- Torregrossa, M. M., Quinn, J. J., & Taylor, J. R. (2008). Impulsivity, compulsivity, and habit: The role of orbitofrontal cortex revisited. *Biol Psychiatry*, *63*, 253-255.

- Trivers, R. (1971). The evolution of reciprocal altruism. *Q. Rev. Biol.* 46, 35–57
- Troy, M., & Sroufe, L. A. (1987). Victimization among preschoolers: Role of attachment relationship history. *Journal of the American Academy of Child and Adolescent Psychiatry*, 26, 166-172.
- U.S. Dept. of Health and Human Services, Health Resources and Services Administration, Maternal and Child Health Bureau. *Health Behavior in School-aged Children Survey, 2001-02* [Computer file]. Calverton, MD: ORC Macro (Macro International Inc.) [producer], 2003.
- van Honk, J., Tuiten, A., van den Hout, M., Koppeschaar, H., Thijssen, J., & de Haan, E. (2000). Conscious and preconscious selective attention to social threat: Different neuroendocrine response patterns. *Psychoneuroendocrinology*, 25, 577-591.
- van Honk, J., & Schutter, D. (2007). Vigilant and avoidant responses to angry facial expressions: Dominance and submission motives. In E. Harmon-Jones & P. Winkielman (Eds.), *Social Neuroscience: Integrating Biological and Psychological Explanations of Social Behavior* (pp. 197-223). New York, NY: The Guilford Press.
- Vigil-Colet, A., & Codorniu-Raga, M. J. (2004). Aggression and inhibition deficits, the role of functional and dysfunctional impulsivity. *Personality and Individual Differences*, 37, 1431-1440.
- Volkow, N. D., Fowler, J. S., Wang, G., Swanson, J. M., & Telang, F. (2007). Dopamine in drug abuse and addiction: Results of imaging studies and treatment implications. *Archives of Neurology*, 64, 1575-1579.
- Wigfield, A. L., Eccles, J. S. (2002). Motivational beliefs, values, and goals. *Annual Review of Psychology*, 53, 109-32.
- Whiteside, S., & Lynam, D. (2001). The five factor model and impulsivity: Using a structural model of personality to understand impulsivity. *Pers Individ Differ*, 30, 669 - 689.
- Yucel, M., Lubman, D. I., Solowij, N., & Brewer, W. J. (2007). Understanding drug addiction: A neuropsychological perspective. *Australian and New Zealand Journal of Psychiatry*, 41, 957-968.
- Zimbardo, P. G., & Boyd J. N. (1999). Putting time in perspective: A valid, reliable individual-differences metric. *Journal of Personality & Social Psychology* December, 77, 1271-1288.
- Zuckerman, M. (1996). The psychobiological model for impulsive unsocialized sensation seeking: A comparative approach. *Neuropsychobiology*, 34, 124-129.

APPENDIX A

Covariances and Correlations – Final Structural Model

		<i>cov</i>	<i>SE</i>	<i>p</i>	<i>r</i>
Neighb. Dng.	ISF	.049	.008	<.001	.378
res3	res2	-.186	.040	<.001	-.455
err8	err6	.181	.021	<.001	.351
err4	err5	.264	.037	<.001	.236
err21	err23	.125	.031	<.001	.223

Note. res2=substance abuse; res3=submission; err4=Q89A; err5=Q83; err6=Q69; err8=Q70A; err21=67G; err23=Q67D

Variances – Final Structural Model

	Factor/Indicator	<i>s</i> ²	<i>SE</i>	<i>p</i>
Neighb. Dng.	N/A	.141	.015	<.001
ISF	N/A	.117	.023	<.001
res3	Submission	.179	.032	<.001
res2	Substance Abuse	.934	.095	<.001
res1	Aggression	.274	.032	<.001
res4	Perceived Prosocial Bx	.478	.032	<.001
err0	Q85A	.299	.022	<.001
err1	Q85C	.311	.029	<.001
err4	Q89A	2.354	.101	<.001
err2	Q87	1.380	.076	<.001
err11	Q70D	.212	.021	<.001
err10	Q70B	.334	.028	<.001
err21	Q67G	.697	.047	<.001
err22	Q67B	.387	.031	<.001
err23	Q67D	.452	.036	<.001
err9	Q70G	.338	.030	<.001
err16	Q81E	.598	.033	<.001
err15	Q81B	.456	.030	<.001
err14	Q81A	.781	.036	<.001
err13	Q80	.422	.016	<.001
err8	Q70A	.521	.034	<.001
err7	Q70C	.209	.019	<.001
err6	Q69	.509	.033	<.001
err5	Q83	.531	.027	<.001
err24	Q62D	.785	.036	<.001
err25	Q62E	.456	.029	<.001
err26	Q62F	.508	.030	<.001
err18	Q66	.435	.032	<.001

APPENDIX B
Final Structural Model – Both Sexes

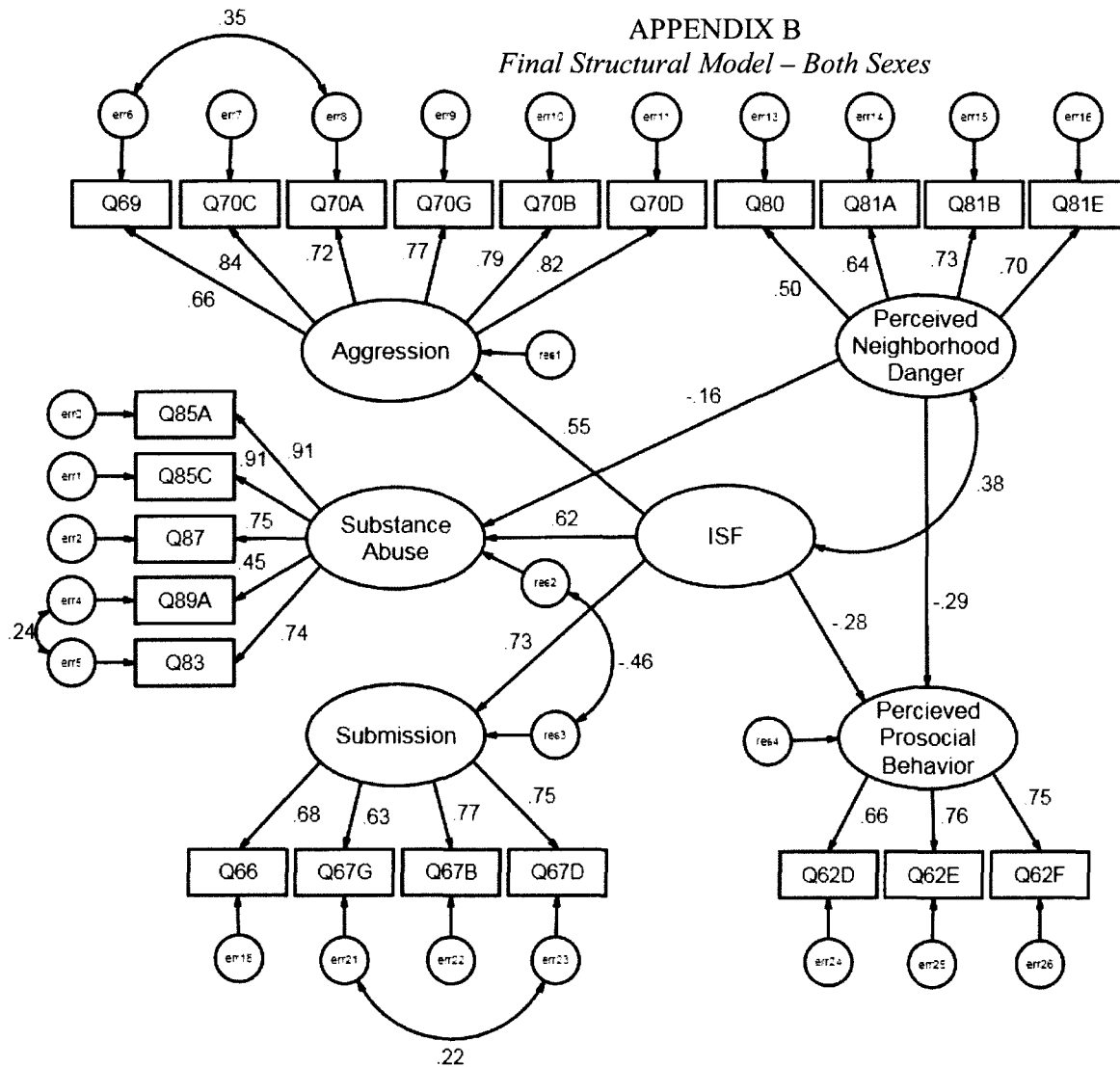

APPENDIX C
Final Structural Model – Males

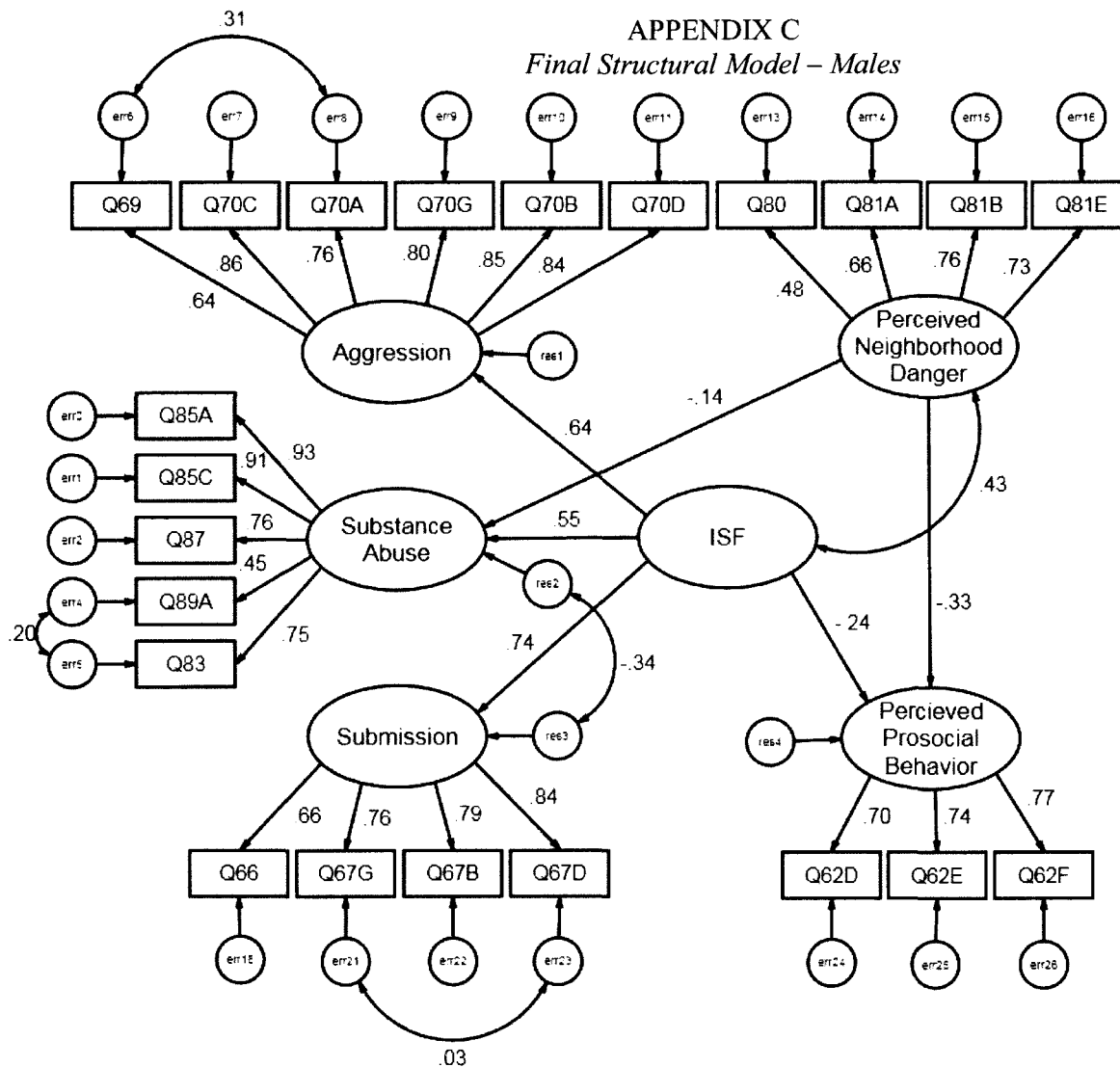

APPENDIX D
Final Structural Model – Females

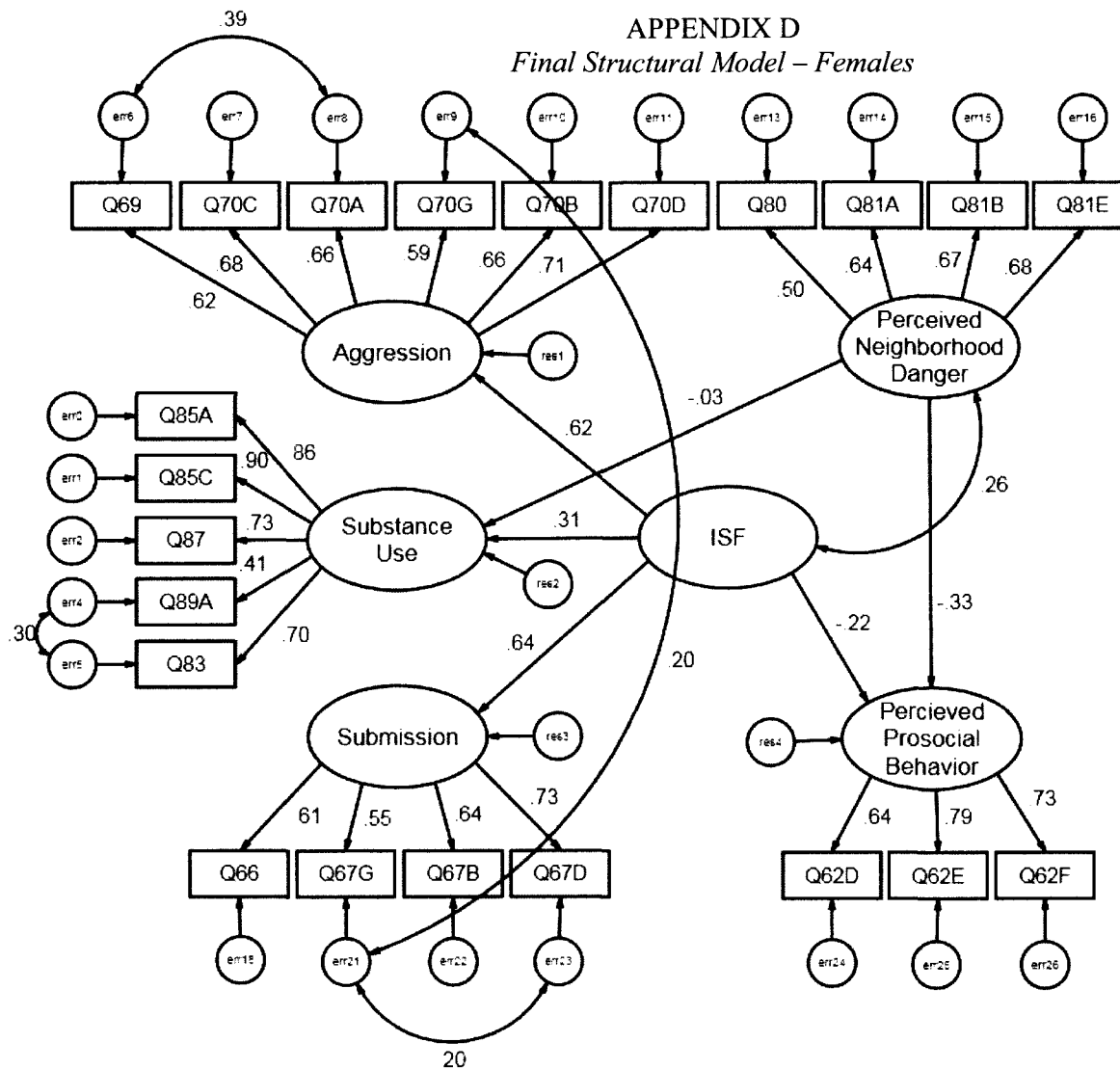

CURRICULUM VITAE

GEORGE B. RICHARDSON

Lecturer & Graduate Research Assistant
Department of Educational & Counseling Psychology
College of Education & Human Development
University of Louisville
Louisville, KY 40292
gbrich01@louisville.edu
Cell: 502-797-3489

2011

ACADEMIC BACKGROUND

2011	Ph.D. University of Louisville Counseling & Personnel Services Concentration: Mental Health Counseling
2008	M.ED. University of Louisville Counseling & Personnel Services Concentration: Mental Health Counseling
2006	B.A. University of Louisville Psychology Concentration: Social Science

PROFESSIONAL LICENSURE

Licensed Professional Counselor Associate (Preliminary Approval), Commonwealth of
Kentucky

PROFESSIONAL EXPERIENCE

January 2011-May 2011	Lecturer Department of Teaching & Learning College of Education & Human Development University of Louisville
-----------------------	---

- January 2011-May 2011 Graduate Research Assistant
National Research Center for Career & Technical
Education
University of Louisville
- August 2010-December 2010 Doctoral Fellow
School of Interdisciplinary & Graduate Studies
University of Louisville
- August 2008-August 2010 Graduate Research Assistant
National Research Center for Career & Technical
Education
University of Louisville
- August 2008-December 2008 Graduate Teaching Assistant
Department of Educational & Counseling Psychology
College of Education & Human Development
University of Louisville
- August 2006-August 2008 Senior Therapeutic Aide
KY IMPACT
Seven Counties Services, Inc.

RELATED OCCUPATIONAL EXPERIENCE

- August 2010-December 2010 Counseling Intern
3rd Step Program
Volunteers of America
- August 2007-August 2008 Counseling Intern
Lighthouse Center for Adolescent Recovery
Seven Counties Services, Inc.

PROFESSIONAL PAPERS

- Hardesty, P., Nichols, A., Richardson, G. B., & Myers, M. Who directs college career counseling centers, and who is served? (Manuscript in preparation)
- Hardesty, P., & Richardson, G. B. The structure and validity of the Multidimensional Social Support Questionnaire. (Submitted for review)
- MacDonald, G., Higgins, J. P. T., Ramchandani, P., Valentine, J. C., Bronger, L., Klein, P., O'Daniel, R., Pickering, M., Rademaker, B., Pickering, M., Richardson, G. & Taylor, M. (in press). *Cognitive-behavioural interventions for children who have been sexually abused*. Cochrane Database of Systematic Reviews.

Pan, Y. J., Richardson, G. B., Valentine, J., & Banister, A. Modeling the effects of academic and social integration on college student success: A systematic review. (Manuscript in preparation)

Richardson, G. B. An immediate survival focus: Synthesizing life history theory and dual process models to explain substance abuse. (Manuscript in preparation)

Richardson, G. B. Testing for an immediate survival focus: Linking substance abuse, fight, flight, and prosocial behavior. (Manuscript in preparation)

Richardson, G. B., Hardesty, P., & Jeppsen, B. Family idealization and religiousness, peer drug use, and psychological health: A structural model. (Manuscript in preparation)

TECHNICAL REPORTS

Richardson, G. B., Aliaga, O. A., Sawyer, J. M., & Pearson, D. (2011). *Analysis of math-in-CTE testing: Mississippi Department of Education 2009-2010 school year*. Louisville, KY: National Research Center for Career and Technical Education.

Richardson, G. B., Aliaga, O. A., Sawyer, J. M., & Pearson, D. *Analysis of science-in-CTE testing: Oklahoma Department of Education 2009-2010 school year*. Louisville, KY: National Research Center for Career and Technical Education. (Manuscript in preparation)

PEER REVIEWED PRESENTATIONS

Richardson, G. B. (2011). An immediate survival focus: Linking substance abuse, fight, flight, and prosocial behavior. Research poster to be presented at the 2011 Convention of the American Psychological Association. Washington, DC, August 4, 2011.

Richardson, G. B. (2011). On the nature of absolutes: An adaptive and cognitive framework. Poster to be presented at the 2011 Convention of the American Psychological Association. Washington, DC, August 4, 2011.

Richardson, G. B. (2010). An immediate survival focus: Linking substance abuse, fight, flight, and prosocial behavior. Presentation given at the 2010 Conference of the Kentucky Counseling Association. Louisville, Kentucky, October 21, 2010.

Richardson, G. B., & Hardesty, P. (2010). The psychosocial effects of family idealization and religiousness. Research poster presented at the 2010 Convention of the American Psychological Association. San Diego, California, August 14, 2010.

Hardesty, P., & Richardson, G. B. (2009). Testing the structure of social support among alternative school students. Research poster presented at the 2009 Convention of the American Psychological Association. Toronto, ON, Canada, August 9, 2009.

Hardesty, P., Nichols, A., Richardson, G. B., & Myers, M. (2009). Who directs college career counseling centers, and who is served? Research poster presented at the 2009 Convention of the American Psychological Association. Toronto, ON, Canada, August 6, 2009.

Richardson, G. B., & Hardesty, P. (2009). Testing the structure of social support. Research poster presented at Spring Research Conference 2009. Louisville, KY, April 4, 2009.

INVITED PRESENTATIONS

Richardson, G. B. (2010). An immediate survival focus: Linking substance abuse, fight, flight, and prosocial behavior. Presentation given at the Center for Drug Abuse Research Translation (CDART) Research Forum Series. Lexington, KY, October 4, 2010.

GRANTS

Life History Strategy, Academic Achievement, and Career Success. (Completed but not yet submitted). American Educational Research Association. \$20,000 – Principal Investigator.

UNIVERSITY COURSES TAUGHT

Human Development and Learning (Spring, 2011)

Empirical and Theoretical Foundations of Counseling, Dr. Nancy Cunningham (Fall, 2010)

The Psychology of Work, Dr. Patrick Hardesty (Spring, 2010)

Evaluation and Measurement, Dr. Patrick Hardesty (Fall, 2008)

HONORS & AWARDS

The School of Interdisciplinary and Graduate Studies *Doctoral Dissertation Completion Fellowship*, 2010

College of Education and Human Development *Research and Faculty Development Grant*, University of Louisville, 2010, \$800

Graduate Student Council *Travel Grant*, 2010

Graduate Research Assistantship (2008-2010)

Honors, All Sections of Comprehensive Examination, Department of Educational and Counseling Psychology, 2009

Graduate Student Council *Travel Grant*, 2009

International Center *Student Travel Award*, 2009

Outstanding Student in Mental Health Counseling Award (2008-2009), Department of Educational and Counseling Psychology, University of Louisville

Seven Counties Services, Inc. *On the Spot Award for Outstanding Customer Service and Teamwork*, 2008

Golden Key International Honor Society

SERVICE ACTIVITIES

Ad Hoc Reviewer, Division 50 Empirically Supported Treatments Taskforce, 2010

President, Education Graduate Student Association, 2010

Program Chair, Doctoral Student Organization (Fall 2009-Spring 2010)

Member, Doctoral Student Organization (2008-2010)

Panelist, Comprehensive Exam Help Committee, January, 2010

Program Committee Member, Spring Research Conference with the Universities of Louisville, Cincinnati, and Kentucky, 2009

Ad Hoc Reviewer, Spring Research Conference with the Universities of Louisville, Cincinnati, and Kentucky, 2009

Faculty Search Committee, December, 2008

Faculty Search Committee, November, 2008

PROFESSIONAL DEVELOPMENT

Grantsmanship: Navigating the Funding Marketplace, University of Louisville, 2011

Future Faculty Program (including a course on college teaching), University of Louisville, 2009

Workshop on Statistical Methods in Drug Abuse and Health-Related Research, Center for Drug Abuse Research Translation, October, 2008

Effective Strategies for Managing Individuals with Borderline Personality Disorder, Bellarmine University, March, 2008

Introduction to Stages of Change Theory and Techniques of Motivational Interviewing, Division of Mental Health and Substance Abuse: Kentucky Youth First, April, 2008

Depression Center Conference: Challenges in the Treatment of Depression, University of Louisville School of Medicine, October, 2007

Medical Necessity 102: Clinical Documentation, Seven Counties Services Training Institute, March, 2007

PROFESSIONAL ORGANIZATIONS

American Counseling Association (ACA)

IAAOC: International Association of Addictions and Offender Counselors

ACES: Association for Counselor Education and Supervision

Kentucky Counseling Association (KCA)

Kentucky Mental Health Counselors Association (KMHCA)

American Psychological Association (APA)

Division 50: Addictions

Division 24: Society for Theoretical and Philosophical Psychology

References provided upon request.