

University of Louisville

ThinkIR: The University of Louisville's Institutional Repository

Electronic Theses and Dissertations

12-2005

Ethnicity as an independent predictor of incontinence care seeking when theoretical modeling is used.

Michael Heit 1962-
University of Louisville

Follow this and additional works at: <https://ir.library.louisville.edu/etd>

Recommended Citation

Heit, Michael 1962-, "Ethnicity as an independent predictor of incontinence care seeking when theoretical modeling is used." (2005). *Electronic Theses and Dissertations*. Paper 599.
<https://doi.org/10.18297/etd/599>

This Doctoral Dissertation is brought to you for free and open access by ThinkIR: The University of Louisville's Institutional Repository. It has been accepted for inclusion in Electronic Theses and Dissertations by an authorized administrator of ThinkIR: The University of Louisville's Institutional Repository. This title appears here courtesy of the author, who has retained all other copyrights. For more information, please contact thinkir@louisville.edu.

ETHNICITY AS AN INDEPENDENT PREDICTOR OF INCONTINENCE CARE
SEEKING WHEN THEORETICAL MODELING IS USED

By

Michael Heit

B.S., SUNY/ Binghamton 1984

M.D., St. Louis University 1988

M.S.P.H., University of Louisville 2001

A Dissertation Submitted to the Faculty of the
Graduate School of the University of Louisville
In Partial Fulfillment of the Requirements
For the Degree of

Doctor of Philosophy

School of Public Health-Epidemiology/Clinical Investigative Sciences
University of Louisville
Louisville, Kentucky

December 2005

Copyright 2005 by Michael Heit

All rights reserved

ETHNICITY AS AN INDEPENDENT PREDICTOR OF INCONTINENCE CARE
SEEKING WHEN THEORETICAL MODELING IS USED

By

Michael Heit
B.S., SUNY/ Binghamton
M.D., St. Louis University
M.S.P.H., University of Louisville

A Dissertation Approved on

May 27, 2005

by the following Dissertation Committee

Dissertation Director

DEDICATION

This dissertation is dedicated to my wife

Mrs. Michelle Hawk Heit

and my two children

Meaghan Elizabeth Heit

Kaitlyn Michelle Heit

for their patience and support throughout this long process

ACKNOWLEDGEMENTS

I would like to thank Dr. Bruce Gale and his staff at the University of Louisville Survey Research Center for their exhaustive effort in surveying 275 respondents whose data is the basis for this dissertation work. I would also like to thank Margaret Yarborough and her staff at Margaret Yarborough & Associates for recruiting focus group respondents, providing us with outstanding focus group facilities in Alameda, CA and surveying focus group respondents during Phase II of this study. I would also like to acknowledge Linda Blackwell, R.N., CCRC for her tireless work as my research coordinator and focus group moderator for this study. Additionally, I would like to thank Susan Kelly, PhD. for developing my interest in medical sociology, and health disparities, and her advisory role in the development, and execution of the research that is the foundation for this dissertation. Finally, I would also like to thank all focus group and survey respondents for their time and effort in completing the 35 minute surveys that will provide physicians and incontinent women with a better understanding of incontinence care seeking behavior.

ABSTRACT

ETHNICITY AS AN INDEPENDENT PREDICTOR OF INCONTINENCE CARE SEEKING WHEN THEORETICAL MODELING IS USED

Michael Heit, M.D., M.S.P.H.

August 2005

Urinary incontinence is a major public health problem affecting 30% of community dwelling women aged 35-85. Urinary incontinence may have a significant impact on activities of daily living depending on the severity of symptoms. Women with urinary incontinence suffer from psychological distress associated with the self-imposed social isolation required to hide their disorder from friends and family. The annual health care costs for managing urinary incontinence has been estimated at nearly 26 million dollars and 70% of these costs are attributed to remedies that are not covered by healthcare insurance. Yet, only 25-50% of incontinence sufferers seek professional care for symptoms. The prevalence rate of urinary incontinence is similar for women from varying ethnic backgrounds. Yet health care disparities may exist amongst incontinent women from varying ethnic backgrounds for a number of reasons including access to care differences. Recently, one study identified ethnicity as an independent predictor of incontinence care seeking during bivariate analysis. However measures of symptom severity explained the association between ethnicity and incontinence care seeking during multivariate analysis. The purpose of this study was to determine if ethnicity was an

independent predictor of incontinence care seeking using the Theory of Care Seeking Behavior to guide our research.

Both Blacks and Hispanics were less likely to seek incontinence care than Whites, independent of socioeconomic status and measures of symptom severity. None of the measured psychosocial (affect, utility, norms and habits) and barrier variables from the Theory of Care Seeking Behavior explained the association between ethnicity and incontinence care seeking.

The social construct of ethnicity includes bias, stereotyping, cultural competence, religiosity, spirituality, and lay illness which could explain the between ethnic group differences in incontinence care seeking identified in my study. Measurement of these variables, in conjunction with clinical and demographic, or psychosocial and barrier variables from the Theory of Care Seeking Behavior may explain the within ethnic group differences in incontinence care seeking, if they truly exist. Researchers should be able to develop modifiable predictor-specific interventions aimed at reducing health care disparities between ethnic groups by increasing the percentage of all incontinent women who seek care.

TABLE OF CONTENTS

	PAGE
ACKNOWLEDGEMENTS	iv
ABSTRACT	v-vi
LIST OF TABLES	xii
LIST OF FIGURES	xiii
CHAPTER	
I. INTRODUCTION	1
II. REVIEW OF EXISTING LITERATURE	6
Urinary Incontinence as a Public Health Problem	6
• Prevalence and “Bothersomeness”	6
• Impact of Urinary Incontinence on Quality of Life	13
• Cost of Urinary Incontinence Care	19
• Ethnicity and Urinary Incontinence	20
Framing the Problem of Incontinence Care Seeking	26
Using Theoretical Modeling	

• Clinical and Demographic Predictors of Incontinence Care Seeking from the Medical Literature	35
• Psychosocial Predictors of Incontinence Care Seeking from the Medical Literature	41
• Barrier Predictors of Incontinence Care Seeking from the Medical Literature	46
• Ethnicity and Incontinence Care Seeking from the Medical Literature	51
III. Research Methodology	56
Phase I – Adapting the Theory of Care Seeking Behavior for the Clinical Problem of Urinary Incontinence	56
• Focus groups	56
• Sample	56
• Recruitment	57
• Focus Group Demographics	58
• Procedure	58
Phase II – Establishing the Clarity, Comprehensiveness and Acceptability of the Survey Instrument Capable of Measuring the Incontinence Specific Predictor Variables in the Theory of Care Seeking Behavior	61
• Focus groups	61
• Sample	61
• Recruitment	62

• Focus Group Demographics	62
• Procedure	63
Phase III – Use computer assisted telephone interviews (CATI)	66
to establish predictors of incontinence care seeking for an ethnically heterogeneous female population, based on the framework of the Theory of Care Seeking Behavior	
• Sample	66
• Recruitment	67
• Sample Size	68
• Procedures	69
Survey Instrument	70
Dependent Variables in the Survey Instrument	72
• Incontinence Care Seeking	72
Independent Variables in the Survey Instrument	73
Psychosocial variables	73
• Affect variable	73
• Utility variable	74
• Norms variable	76
▪ Habit variable	79
Clinical and Demographic Variables	80
• Preventive Health Behaviors	80
• Physical Exam Frequency	81
• Incontinence severity	82

• Health locus of control	83
• Socioeconomic status	84
• Impact of urinary incontinence on activities of daily living	85
• Ethnicity	86
• Symptom change	87
• Marital status	88
• Symptom duration	88
• Age	88
• UI is a medical problem	88
• Close relatives or friend with urinary incontinence	89
• Pads per day	89
• Incontinence type	89
• Health insurance coverage	90
Barrier Variable	90
Statistical Analysis	92
• Establishing the Factor Validity of the Expectations of Incontinence Care Seeking Questionnaire (EICS-Q) and the Barriers to Incontinence Care Seeking Questionnaire (BICS-Q)	92
• Establishing Predictors of Incontinence Care Seeking for an Ethnically Heterogeneous Incontinent Female Population as Guided by the Theory of Care Seeking Behavior	94
• Hypothesis Testing	95

IV. RESULTS	98
• Survey Respondent Demographics	98
Establishing the Factor Validity of the Expectations of Incontinence Care Seeking Questionnaire (EICS-Q) and Barriers to Incontinence Care Seeking Questionnaire (BISC-Q)	103
○ Utility Measurement Model	103
○ Barrier Measurement Model	105
Establishing Predictors of Incontinence Care Seeking in an Ethnically Heterogeneous incontinent female population	107
○ Incontinence Care Seeking	107
○ Ethnicity	112
○ Hypothesis Testing Using Logistic Regression Analysis	118
V. DISCUSSION/FUTURE AREAS OF RESEARCH	128
• Hypothesis 1	129
• Hypothesis 2 (and 5)	131
• Hypothesis 3	133
• Hypothesis 4	140
REFERENCES	162
APPENDICES	169
1 Survey Questionnaire	169
2 Expectations of Incontinence Care Seeking Questionnaire	220
3 Barriers to Incontinence Care Seeking Questionnaire	221
CURRICULUM VITAE	222

LIST OF TABLES

TABLE		PAGE
1	The Prevalence of Slight and Significant Incontinence in Nord-Trondelag County of Norway	11
2	Disproportionate Sample Size Requirements for My Computer Assisted Telephone Interviews	69
3	Variables Captured by Survey Instrument	71-72
4	Survey Respondent Demographics	100-101
5	Bivariate Analysis of Care Seeking on Psychosocial Variables	107-108
6	Bivariate Analysis of Incontinence Care Seeking on Clinical and Demographic, and Barrier Variables	109-112
7	Bivariate Analysis of Psychosocial Variables on Ethnicity	113-114
8	Bivariate Analysis of Clinical and Demographic, and Barrier Variables on Ethnicity	115-118
8	Logistic Regression of Incontinence Care Seeking on Psychosocial Variables	119
9	Logistic Regression of Incontinence Care Seeking on Clinical and Demographic Variables Adjusting for Psychosocial Variables	121-123
10	Logistic Regression of Incontinence Care Seeking on Psychosocial, and Clinical and Demographic Variables Entered Simultaneously	125-126

LIST OF FIGURES

FIGURE		PAGE
1	Age Specific Period Prevalence of Storage Disorders	7
2	Age Specific Incidence and Remission Rates of Storage Disorders	8
3	Knowledge Gap between Symptom Appraisal and Impact or Care Seeking for Symptoms	26
4	Lauver's Theory of Care Seeking Behavior	29
5	The Health Needs of Incontinent Women in the U.K.	47
6	Measurement Model for Expectations of Incontinence Care Seeking Questionnaire (EICS-Q)	103
7	Measurement Model for Barriers to Incontinence Care Seeking Questionnaire (BICS-Q)	105
8	Hypothesized Causal Model for Incontinence Care Seeking	145
9	Unmeasured Variables Hypothesized to Explain the Association of Ethnicity on Incontinence Care Seeking	151

CHAPTER I

INTRODUCTION

The identification of predictors of incontinence care seeking is an important precursor to the development of strategies aimed at modifying care seeking behaviors in an attempt to mitigate the negative quality of life, psychological, and public health impact associated with urinary incontinence. If clinicians and administrators understood women's reasons for, and barriers to incontinence care seeking it would contribute to their ability to bring symptomatic yet untreated individuals into the healthcare system earlier in the disease process at points where interventions might prevent higher levels of morbidity and loss of quality of life. Existing epidemiologic studies have established predictors of care seeking behavior for Whites. How these predictors apply to different racial groups is unknown.

Urinary incontinence has a negative impact on quality of life and is associated with psychological dysfunction which can be corrected with formal diagnostic and treatment strategies. The costs of incontinence self care are high contributing significantly to 1.3 trillion dollars we spend annually on healthcare in the United States alone. Urinary incontinence does not appear to discriminate against any individual ethnic group, affecting all groups equally.

Care seeking is a prerequisite to formalized diagnosis and treatment of urinary incontinence. Incontinence care seeking rates have been surprisingly low for affected

individuals. Seventy-one percent of continent persons believe that incontinence would have a great deal or fair amount of effect on their lifestyle. If incontinent, 95% of continent subjects would go to their doctor and only 15% thought they would feel embarrassed by so doing. In contrast only 36% of incontinence sufferers feel that their condition had a great deal or fair amount of effect on their lifestyle. Only 52% of incontinence sufferers consulted their doctor upon realizing that it was a problem [Brocklehurst 1993].

According to Hunskar, both epidemiological and qualitative incontinence research should be encouraged in order to understand cultural, religious, and other reasons for help-seeking behavior worldwide [Hunskar 2000].

The validity of the existing incontinence care seeking literature is threatened by three factors. The external validity of the existing incontinence care seeking literature is threatened by the ethnic homogeneity (primarily White) of the sample populations under study, and the lack of comparative studies when ethnic minorities are surveyed. The external validity of the existing incontinence care seeking literature is also threatened by studies that are conducted in countries where a national health service exists. Finally, the internal validity of the existing incontinence care seeking literature is threatened by selection bias when working populations are recruited from lists of Health Maintenance Organization (HMO) enrollees or primary care physician offices. Studies that are conducted in countries where a national health service exists, or whose working populations were recruited from lists of HMO enrollees or primary care physician offices, underestimate the association of clinical and sociodemographic, psychosocial, and barrier

variables with incontinence care seeking because access to care was always available or was a prerequisite for recruitment.

None of the existing incontinence care seeking literature has benefited from the use of theoretical models to examine the association of clinical and sociodemographic, psychosocial, and barrier variables with incontinence care seeking. Theories designed to explain health behaviors act as roadmaps or guidelines that direct research providing an understanding of such behaviors more efficiently. Theoretical models can help synthesize a body of research more easily, to understand a behavior more fully, and propose ways in which an intervention may be most effective [Lauver 1992a].

The broad long term objective of my research is to increase the percentage of women who seek care for urinary incontinence. I took the initial steps to meet this objective by using the Theory of Care Seeking Behavior to identify clinical and sociodemographic, psychosocial, and barrier variables that predicted incontinence care seeking for a racially heterogeneous incontinent female population.

My literature review opens with a section discussing the reach of urinary incontinence as a significant public health problem, in an effort to provide the reader with a perspective on why incontinence care seeking is an important topic for research. An overview of the existing incontinence care seeking literature follows.

In phase I of my study, I adapted the Theory of Care Seeking Behavior for the clinical problem of urinary incontinence. I conducted focus groups to create two measurement tools, necessary to accomplish this task: the Expectations of Incontinence Care Seeking Questionnaire (EICS-Q) and the Barriers to Incontinence Care Seeking Questionnaire (BICS-Q).

In phase II of my study, I pilot tested my survey to establish its clarity, comprehensiveness, and acceptability as an instrument capable of measuring the clinical and sociodemographic, psychosocial, and barrier variables in the Theory of Care Seeking Behavior.

In phase III of my study, I collected and analyzed data from 275 ethnically heterogeneous incontinent females to establish the factor validity of my Expectations of Incontinence Care Seeking Questionnaire (EISC-Q), and my Barriers to Incontinence Care Seeking Questionnaire (BICS-Q), and establish predictors of incontinence care seeking. I specifically tested the following hypotheses guided by the Theory of Care Seeking Behavior.

- | | |
|--------------|--|
| Hypothesis 1 | Psychosocial variables directly predict incontinence care seeking as guided by the Theory of Care Seeking Behavior |
| Hypothesis 2 | The predictive value of psychosocial variables for incontinence care seeking is modified (interaction effect) by barrier variables as guided by the Theory of Care Seeking Behavior |
| Hypothesis 3 | Clinical and demographic variables, including ethnicity, predict incontinence care seeking after adjusting for psychosocial, and barrier variables contrary to the Theory of Care Seeking Behavior |
| Hypothesis 4 | Clinical and demographic variables, excluding ethnicity, and psychosocial variables explain any significant association between ethnicity and incontinence care seeking. |

Hypothesis 5 The predictive value of clinical and demographic variables, including ethnicity, and psychosocial variables for incontinence care seeking is modified (interaction effect) by barrier variables

Knowledge about predictors of incontinence care seeking can be leveraged by interventions capable of encouraging care seeking behavior modifications for an ethnically heterogeneous incontinent female population.

CHAPTER II

REVIEW OF EXISTING LITERATURE

Urinary Incontinence As A Public Health Problem

Prevalence and “Bothersomeness”

The International Continence Society (ICS) defines urinary incontinence as the complaint of any involuntary leakage of urine. Types of urinary incontinence are characterized by the conditions that provoke urine leakage. The ICS defines the symptom of stress urinary incontinence as the complaint of involuntary leakage on effort or exertion, or on sneezing or coughing. Urge urinary incontinence is the symptom of involuntary leakage accompanied by or immediately preceded by urgency. Mixed urinary incontinence is the symptom of involuntary leakage associated with urgency and also with exertion, effort, sneezing, or coughing [Abrams 2002].

Median female urinary incontinence prevalence estimates from 13 different population studies suggest an increasing prevalence during young life (20-30%), a plateauing prevalence during midlife (30-40%), and an increasing prevalence in the elderly (30-50%) [Hannestad 2000].

However, the prevalence, incidence, and remission rates of this condition depend on the definition used and the sample populations surveyed in cross sectional epidemiologic studies. McGrother received 92,491 (60.2% response rate for prevalence

study) and 23,182 (63% response rate for incidence and remission rate study) completed postal questionnaires from 108 general practices in Leicestershire and Rutland counties, United Kingdom, to examine the prevalence, incidence and remission rates of incontinence and other urinary storage symptoms. Eighty five and one half percent of the sample was self designated as White. The one year period prevalence of storage symptoms defined as nocturia ≥ 2 /night, frequency ≥ 2 -hourly, urgency, monthly or more, or incontinence, mild or more was 51.4%. The one year period prevalence of storage symptoms with quality of life impact defined as a mild, moderate or severe problem or interfering a little or a lot with aspects of life including daily, social and sleeping activities or feelings including bother, discomfort, upset, and distress was 30.4%. Figure 1 illustrates the decrease in age specific prevalence of storage disorders when only symptoms affecting quality of life are considered.

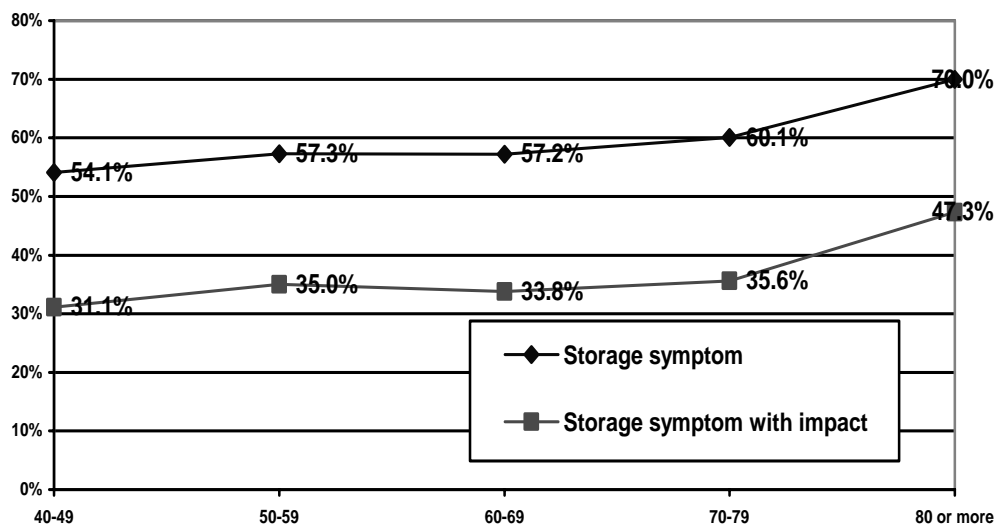

Figure 1. Age specific period prevalence of storage disorders and storage disorders with quality of life impact

The one year incidence rate of storage disorders defined as nocturia ≥ 3 /night; frequency, hourly or more; urgency, monthly or more; or incontinence, moderate or more was 14.1%. The one year remission rate, defined as the absence of previously reported storage disorders was 26%. Figure 2 illustrates the increasing incidence rate and decreasing remission rates associated with an aging population that explain the overall increasing prevalence rates of urinary incontinence in this and many other cross-sectional epidemiologic studies [McGrother 2004].

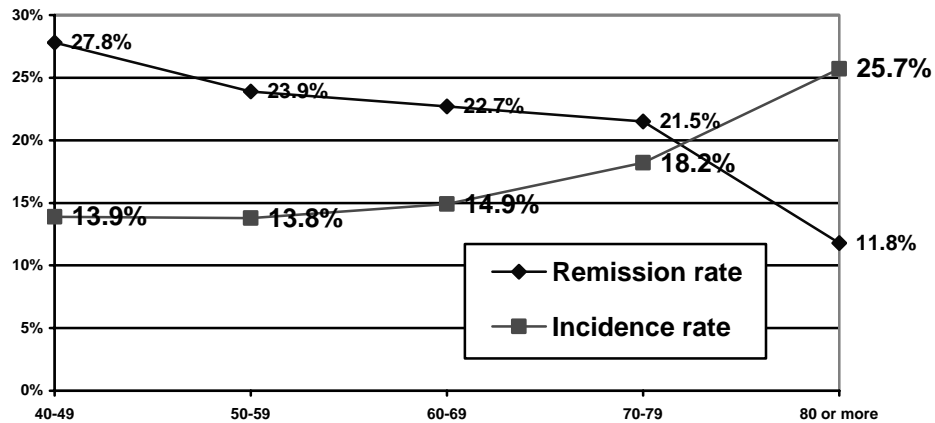

Figure 2. Age specific incidence and remission rates of storage disorders

Two recent population based cross sectional epidemiologic studies have shed additional light on the prevalence and “bothersomeness” of urinary incontinence in the United States and in other populations. Jeter [1990] surveyed 36,500 Help for Incontinent People (HIP) subscribers to get a clear picture of how incontinence was perceived and managed in the American home. HIP is an advocacy and support organization for incontinent people. It is interesting to note that 95.9% of surveyed HIP subscribers were Whites suggesting a disparity in participation in advocacy and support

for affected minority populations. Seventeen and three tenths percent of surveyed HIP subscribers described their incontinence as a major problem with important social implications while 82.7% described it as a relatively minor problem with limited impact on their lifestyle. The mean duration of reported incontinence was 4 years (range 2-12). Ninety seven percent of surveyed HIP subscribers had seen a health professional about their incontinence (37% urologists, 35% family physician, and 17% gynecologists). The high rate of incontinence care seeking suggests that HIP subscribers are highly motivated incontinent individuals who may not be representative of the general population of incontinent individuals that seek care at much lower rates. Only 9.7% said they were helped “very much” while 56.5% reported that their visits were “no help at all.” Behavior modifications such as decreasing fluid intake and frequent toileting were the two practices most commonly used to control loss of urine while bedwetting alarms, “mapping closest bathroom” and avoidance of stress, strain, and exercise were less frequently reported strategies. Only 7.7% of surveyed HIP subscribers reported using pelvic muscle exercises. Information about incontinence was obtained from nonmedical sources: 34.5% from the HIP quarterly report, 25.7% from personal inquiry, and 26.4% from television or print advertisements [Jeter 1990].

Hannestad surveyed 27,936 of 34,785 community dwelling women from Nord-Trondelag County of Norway as part of the Epidemiology of Incontinence in the County of Nord-Trondelag (EPINCONT) Study. The purpose of the study was to measure the prevalence of incontinence in a community survey using standardized instruments to screen for involuntary loss of urine and measure its frequency, quantity, and duration. Urinary incontinence was defined as any leakage of urine without regard to duration,

severity, or impact in this large epidemiologic study. Urinary incontinence was reported by 25% (95% CI 24.1, 25.2) of the survey sample population.

Fifty percent (95% CI 49.1, 51.5%) of women surveyed for the EPINCONT study reported symptoms of stress urinary incontinence, 36% (95% CI 34.4, 36.7%) reported symptoms of mixed urinary incontinence, and 11% (95% CI 10.4, 11.9%) reported symptoms of urge incontinence. The prevalence of urinary incontinence increased with increasing age, with peak prevalence rates around middle age and among the elderly. Forty three percent (95% CI 41.5, 44%) reported “slight incontinence” defined as leakage of drops a few times a month, 31% (95% CI 30.4, 32.7%) reported “moderate incontinence” defined as daily leakage of drops of urine, and 26 % (95% CI 24.6, 26.8) reported “severe incontinence” defined as larger amounts of urine leakage at least once a week. The prevalence of “severe urinary incontinence” increased with increasing age.

Two thirds of incontinent women stated that their incontinence was a minor problem, while one third stated that their incontinence was a bother. The impact of urinary incontinence varied in survey respondents based on the severity of symptoms and the incontinence type. They found a positive correlation ($r = 0.56$) between the incontinence severity index and the rating of incontinence as a problem. Forty percent of women with mixed urinary incontinence symptoms were bothered compared to 36% of women with urge incontinence symptoms, and 24% of women with stress incontinence symptoms. Only 26% of community dwelling women in the study had consulted a physician about their urine leakage.

Consultation with a physician by a survey respondent varied based on impact of incontinence and its symptom severity. Seven percent of the study population had

“significant” incontinence defined as the fraction of women with moderate and severe urinary incontinence on the severity index and who were bothered by their condition. From a public health perspective, the authors suggest an estimation of the total extent of symptoms that may provide an incentive for information and self-care programs for those with “slight” incontinence, and professional help for those with “significant” incontinence [Hannestad 2000]. (Table 1)

Table 1

The Prevalence Of Slight And Significant Incontinence In Nord-Trondelag County Of Norway (n = 6194 incontinent respondents or 25% of the total population surveyed)

Impact	Incontinence Severity			Totals
	Slight	Moderate	Severe	
Bothered	265 (10%)	664 (34%)	1162 (73%)	2091
Not Bothered	2384 (90%)	1289 (66%)	430 (27%)	4103
Totals	2649	1953	1592	6194

However further questions must be answered before we use the “significance” of urinary incontinence as a criterion for rationing professional help for affected individuals who do seek care. Symptom bother may not be an adequate measure of an affected individual’s desire for incontinence care given the stigmatizing nature of the condition. Specifically, the authors did not determine if there was an association between incontinence care seeking and their designation of “significant” versus “insignificant” incontinence. It is unclear why the authors did not consider women who were bothered by slight urinary incontinence as having “significant” incontinence and in need of

professional help. The psychosocial, clinical, and demographic differences for women with moderate and severe urinary incontinence who are bothered by their condition (significant incontinence) and women with moderated and severe urinary incontinence who are not bothered (insignificant incontinence) may confound the observed relationship between the “significance” of urinary incontinence and care seeking. Finally, the authors provided no explanation for why only 26% of women sought incontinence care independent of its “significance.”

Clearly, urinary incontinence is a highly prevalent condition with bothersome symptoms dependent partially on the type and symptom severity.

Impact of Urinary Incontinence on Quality of Life

The “true” impact of urinary incontinence on quality of life is primarily dependent on the incontinent population sampled. The impact of urinary incontinence on activities of daily living ranges from 4 to 8% in population based prevalence studies to 12 to 52% in clinical trials [Wyman 1994]. Forty eight percent of incontinent women attending a urodynamic clinic reported sexual difficulties and 40% of women seeking treatment for their incontinence avoided sexual activity [Wyman 1990]. However it may be unreasonable to generalize findings from care seekers participating in clinical trials to an incontinent population from prevalence studies because care seekers in clinical trials are likely effected by severe symptoms with a greater impact on activities of daily living.

Incontinence type has been associated with the impact of urinary incontinence on quality of life. Wyman found that women with urge and/or mixed incontinence had higher psychosocial impact scores as measured by the Incontinence Impact Questionnaire than women with stress incontinence [Wyman 1990]. Frazier showed that women with urge incontinence perceived greater symptom severity than women with stress incontinence which may explain why urge incontinence has a greater impact on incontinence specific quality of life than stress incontinence. Women with pure urge incontinence had a greater number of sexual difficulties than women with stress or mixed incontinence [Wyman 1990].

Tolerance of and response to incontinence symptoms, such as impact on activities of daily living, are heterogeneous, and unique to the affected individual [Wyman 1990].

For example, Hunskar surveyed 76 incontinent women, using the Sickness Impact Profile to examine their quality of life according to age, symptom group, amount

of leakage and duration. In the stress incontinence subgroups, elderly women had significantly lower total and psychosocial dysfunction than the middle aged group after adjusting for duration and symptom severity. Older women with stress incontinence may have considered incontinence “a normal part of aging” and adapted to their symptoms remaining unaware of its impact on their activities. Alternatively, elderly women may be less active overall than middle aged women thereby reducing their urine leakage triggers or limiting its impact on quality of life for a given level of incontinence. Middle aged women with stress incontinence symptoms had higher scores on emotional behavior, recreation, and pastimes than elderly women, indicating that middle aged women with stress incontinence symptoms experience a more severe impact on their quality of life in these areas. The researchers hypothesized that middle aged women with stress incontinence symptoms were less restrained by mobility and traveling than elderly women because they could often predict the kind of movement or activity that triggers stress related urine leakage and protect themselves from exposure.

Dysfunction did not differ significantly between middle aged and elderly women with urge incontinence symptoms. Both total and psychosocial dysfunction was worse for women with urge incontinence symptoms compared to women with stress incontinence symptoms. Women with urge incontinence symptoms tended to lose larger amounts of urine and to leak less predictably than women with stress incontinence symptoms which may explain why age did not explain any variance in dysfunction after adjusting for symptom severity in women with urge incontinence symptoms.

Alternatively, women with urge incontinence have higher scores on measures of anxiety,

depression, and hysteria compared to their stress incontinent cohort independent of symptom severity [Hunskaar 1991].

Urinary incontinence has been associated with affective disorders in symptomatic individuals. Nygaard surveyed 5,701 women aged 50-59 years of age and found that women with severe urinary incontinence were 80% more likely to experience significant depression and women with mild to moderate severity of urinary incontinence were 40% more likely to experience depression compared to asymptomatic women. Mehta found that urinary incontinence was associated with a 50% increased risk of anxiety for both men and women. Bogner reported that women with severe urinary incontinence causing functional impairment had a 4-fold increased risk of anxiety compared to asymptomatic women [Miner 2004].

Chiari found that persons with urge urinary incontinence scored higher on inner anger and anger trait scales of the State-Trait Anger Expression Inventory. They also scored higher for depression on the CES-D scale and the Illness Behavior Questionnaire and had more irritability and general hypochondriasis than persons with stress or mixed urinary incontinence. Freeman examined 57 persons with detrusor (bladder) instability and 22 persons with stress urinary incontinence and found that those with detrusor instability had significantly more anxiety, neuroticism, hostility, and depression, than asymptomatic controls. These symptoms did not differ between persons with stress urinary incontinence and asymptomatic controls. Persons with urinary incontinence, without regard to type, scored higher than asymptomatic controls on measures of moodiness, helplessness, sadness, pessimism, general hypochondriasis, somatization, and

sexual dysfunction on the Minnesota Multiphasic Personality Inventory and the Uplift and Hassle Scales [Heymen 2004].

Chiverton (1996) conducted a survey of 58 out of 125 women participating in an ongoing project of 511 community residents self described as having uncontrolled urine loss and/or excessive daytime toileting. The purpose of the cross-sectional survey was to test the hypothesis that women who perceive a greater sense of mastery and self esteem were better prepared to deal with incontinence, did not become depressed, and maintained a higher quality of life than women with a poor sense of mastery and self-esteem. Twenty two percent of surveyed women who completed the questionnaire were rated as clinically depressed, as measured by the Beck Depression Inventory, compared to a lower rate of depression in the general population (6%). They found a negative correlation between mastery and depression ($r = -0.70, p < 0.01$) and self esteem and depression ($r = -0.62, p < 0.01$). Both mastery and self esteem were independent, negative correlates of depression, with mastery explaining 49% and self esteem explaining 33% of the variance in depression scores. Similarly, mastery was an independent positive correlate of quality of life for incontinent women explaining 40% of the variance in quality of life scores. Depression and self esteem were not correlated with quality of life in the final model.

These findings have several implications for the diagnosis and management of urinary incontinence. First, the data do not support a mediating effect of depression on quality of life for incontinence sufferers. Second, mastery may be associated with incontinence care seeking. Incontinent women who master self care strategies may be less likely to seek formal care because they are able to maintain their quality of life at

levels they have become accustomed to. Conversely, incontinent women who are unable to master self care strategies may not be able to maintain their quality of life which may become the impetus for incontinence care seeking. Improved patient outcomes may be possible by including an evaluation of the patient's sense of mastery early in the diagnosis and formal treatment of incontinence, once care seeking has occurred. If a woman with urinary incontinence believes in and is able to master formalized treatment strategies, she may not become depressed. Alternatively woman with urinary incontinence who master formalized treatment strategies may maintain a high quality of life, without an effect on depression. Failure to utilize treatment strategies or the lack of belief in the effectiveness of these strategies may result in a depressive episode [Chiverton 1996].

Daud used grounded theory to qualitatively study older women's experience of urinary incontinence accidents or other problems related to urinary incontinence. According to Daud, urinary incontinence provided a strong incentive to develop an effective continence care system which may include incontinence care seeking to protect their self esteem. If they were successful in this task it was possible that they could lead "normal lives" [Ashworth and Hagan 1993].

It is difficult to establish a causal relationship between urinary incontinence and affective disorders including anxiety and depression. Studies have shown that psychological functioning improves with treatment of urge urinary incontinence utilizing biofeedback therapy, and bladder training, exceeding the improvement seen with medications. Psychological functioning also improves after successful surgery for stress urinary incontinence [Heymen 2004]. These studies suggest that successful surgery,

improved self-esteem, self efficacy, and mastery associated with self-treatment strategies like bladder training and biofeedback may have a greater positive impact on the psychosocial well being of affected individuals compared to taking medication.

Costs of Urinary Incontinence Care

The costs of urinary incontinence can be prohibitive. Health care costs associated with urinary incontinence can be subdivided into direct, indirect, and consequence costs. Direct costs of urinary incontinence include physician and other health care provider fees, hospital fees, costs of medications, costs of continence pads or other appliances and transportation costs for obtaining health care, once care has been sought. Indirect costs of urinary incontinence include individual and societal costs from work absenteeism, impaired work performance, and reduced wages related to change in job status. Consequence costs of urinary incontinence include costs related to the sequelae of urinary incontinence such as skin breakdown, etc. Wilson (2001) estimated the annual direct care costs of urinary incontinence in 1995 United States dollars at \$16.3 billion dollars (\$12.4 billion for women, and \$3.8 billion for men). Yet these estimated direct costs for urinary incontinence did not take into account the low rates of incontinence care seeking in affected individuals. The annual direct health care costs of urinary incontinence in 1995 United States dollars was estimated at \$40.1 billion dollars when all affected individuals were considered. The urinary incontinence care costs (\$40.1 billion/annually) are similar to the costs of caring for patients with congestive heart failure (\$46 billion/annually) and diabetes mellitus (\$41.4 billion/annually). Unfortunately, 70% of these direct costs for urinary incontinence are uncovered by health insurance requiring an out of pocket expense for such items as laundry, dry cleaning, incontinence pads, and deodorants, etc. [Wilson 2001].

Clearly affected individuals bear the lion's share of the financial burden for the health care costs associated with the management of urinary incontinence [Minor 2004]

Ethnicity and Urinary Incontinence

Urinary incontinence was initially studied only in White populations because minorities were underrepresented in homogeneous populations of Western Europe, rural America and clinical trials from tertiary care centers. More recent evidence suggests that minority populations have similar prevalence rates of urinary incontinence as majority populations although disorder type may differ. The Established Populations for Epidemiologic Studies of the Elderly (EPESE) Project reported an equal prevalence of urinary incontinence among Whites and Blacks. White subjects had a prevalence of pure genuine stress incontinence 2.3 times greater than Black subjects despite similar overall urinary incontinence prevalence rates [Bump 1993]. This epidemiologic finding was supported by functional and morphologic studies which showed that nulliparous Blacks had greater urethral sphincter capacity than nulliparous White women [Howard 2000].

Waetjen used the 1998 National Hospital Discharge Survey database to estimate the annual number of inpatient stress urinary incontinence surgeries in the United States. They found that White women had an overall stress incontinence surgery rate that was nearly five times greater than for Black women (11.6 cases per 10,000 women vs. 2.6 cases per 10,000 women). They also found racial differences in the complication rates associated with urinary incontinence surgery (20.6% Blacks vs. 9.7% Whites). The authors chose to focus on the psychosocial differences and de-emphasized anatomic or physiologic differences between the races to explain their findings. Differences in urinary incontinence surgery have been explained by differences in socioeconomic status, insurance status, access to and utilization of care, patient reporting or physician

ascertainment of incontinence symptoms, and variations in general attitudes regarding elective surgery, rather than race [Waetgen 2003].

Studies conducted in tertiary care centers are subject to selection bias because the populations sampled had access to care and likely underestimated minority populations barriers to care. Minority populations are more likely to face barriers associated with socioeconomic factors. It is clearly possible that minority populations with stress urinary incontinence self manage their disorders because of these barriers to care. Minority populations with urge urinary incontinence may seek to overcome these barriers to care because of the unpredictability of urine loss and greater impact that urge urinary incontinence has on quality of life, compared to stress urinary incontinence. White populations are less likely than minority populations to face similar socioeconomic barriers which increase the probability they will seek incontinence care for stress urinary incontinence, adjusting for measures of symptom severity and impact of urinary incontinence on quality of life. Therefore samples drawn from tertiary care centers will likely show a higher prevalence of urge incontinence in minority populations and a higher prevalence of stress incontinence in White populations.

For example, Jackson analyzed baseline data of White and Black women aged 70-79 years old, participating in the Health, Aging, and Body Composition Study to estimate the prevalence of and factors related to urinary incontinence by type. Nine and six tenths percent of women reported daily incontinence, 11.6% reported weekly incontinence, and 24% reported leaking urine less than weekly, in the prior 12 months. Of the women with at least weekly incontinence, urge urinary incontinence predominated (42%) followed by stress urinary incontinence (40%), and urinary incontinence unrelated to stress or urge

(14%). Nearly twice as many non-Hispanic White women compared to Black women reported urinary incontinence of any type weekly or more often (27% vs. 14%). White race was associated with 3-fold higher odds for stress urinary incontinence than black race. The authors found these findings surprising because Black women were more likely to be obese (BMI OR 1.33 95% CI 1.1, 1.6 for stress urinary incontinence) and have diabetes (Type II DM OR 3.5 95% CI 1.55, 7.91 for urge urinary incontinence) in the general population compared to Whites. The authors hypothesized that reporting bias may partially explain these differences; in that Black women may be less likely to report urinary incontinence than White women. Alternatively, access to care differences may have also played a role considering that the study sample was recruited from clinical health centers where incontinent White women may have greater access to care than incontinent Black women [Jackson 2004].

Duong retrospectively reviewed the urodynamic testing results of 415 incontinent women (195 (47%) Hispanic, 95 (23%) Whites, 66 (16%) Asian, and 59 (14%) Black) in an effort to further describe the problem of urinary incontinence among the most common self described racial and ethnic minority groups in the United States. Black women had lower rates of urodynamic stress incontinence compared with their Hispanic and White counterparts (42% vs. 67%, and 59%). On the other hand, Black women had higher rates of urge urinary incontinence compared to Hispanic, Whites, or Asian women (29% vs. 8%, 15%, and 14%). The incontinence diagnoses in Asian women did not differ significantly from their Hispanic or White counterparts; however, they did have lower rates of urge urinary incontinence compared to Black women despite their advanced age. The authors explained their racial/ethnic differences in incontinence

rates by factors such as body mass index, athletic exercise, tobacco smoking, or occupation that were not controlled for in the analysis. Again, selection bias related to racial/ethnic differences in incontinence care seeking may further explain their findings. The psychosocial impact of urge urinary incontinence is greater than the psychosocial impact of stress urinary incontinence because of the unpredictability, and greater volumes and frequency of urge incontinent episodes. Blacks have greater barriers to incontinence care than Whites or Asians so only Blacks with more “severe” urinary incontinence were sampled for this study conducted in a tertiary care setting [Duong 2001].

Sze surveyed 2370 women attending the Brody Medical School Clinic and the Office of East Carolina University Women’s Physicians for gynecologic care to compare the prevalence of urinary incontinence symptoms in Black (n=799), White (n=932), and Hispanic (n=639) women. Overall a significantly larger percentage of White women reported urinary incontinence than did Black or Hispanic women (41% vs. 31%, and 30%) due primarily to the higher prevalence of stress incontinence among White women (39% vs. 27%, and 24%). Nulliparous Hispanic women under age 30 were significantly more likely to have stress urinary incontinence and/or urge urinary incontinence symptoms (total urinary incontinence) than either Black or White women of similar age and parity. Parous White women between 30 and 50 years of age were significantly more likely to have stress incontinence symptoms than either Black or Hispanic women of similar age and parity. Multiparous Black women between 30 and 50 years of age were significantly more likely to have weekly urge incontinence symptoms than either Hispanic or White women of similar age and parity. Finally, multiparous Black and White women between 30 and 50 years of age were significantly more likely to have

stress and/or urge incontinence (total urinary incontinence) than Hispanic women of similar age and parity. The high prevalence rates of urinary incontinence in Black and Hispanic women (30%) clearly illustrate the need to screen all women irrespective of ethnicity for symptoms of urinary incontinence. Again, any ethnic differences in urinary incontinence rates or types may be explained by selection bias introduced by differential access to health care when survey samples are taken from tertiary care facilities [Sze 2002].

Subsequent population based epidemiologic research provides information about the prevalence of urinary incontinence in ethnically heterogeneous populations unaffected by selection bias. Sampsel surveyed a random sample of 3,302 community based ethnically heterogeneous perimenopausal women (915 (28.1%) Black, 1530 (47%) Caucasian, 284 (8.7%) Hispanic, 249 (7.6%) Chinese, and 280 (8.6%) Japanese women) as part of the Study of Women's Health Across the Nation (SWAN). This study was a prospective, multiethnic, multi-site study of the natural history of the menopausal transition. The purpose of the study was to document the prevalence of mild, moderate, and severe urinary incontinence among ethnically heterogeneous perimenopausal women to identify significant risk factors for urinary incontinence. They also assessed the impact of urinary incontinence on daily life by testing the relationship of incontinence severity to treatment seeking, level of bother, and nighttime voiding. Fifty seven percent of women reported urinary incontinence in the past year with 15% reporting moderate, and 10% reporting severe incontinence. In general, non-white women were significantly less likely to report any urinary incontinence than White women (Blacks without myomatous uteri OR 0.31 95% CI 0.23, 0.40, Chinese without a college education OR 0.35, 95% CI

0.27, 0.71, and Japanese women OR 0.58, 95% CI 0.39, 0.86) in the bivariable analysis. However, ethnicity was not associated with the report of moderate or severe urinary incontinence in the multivariable analysis after adjusting for perimenopausal status, body mass index, diabetes, and current smoking. Overall, 50% of the sample was bothered by their urinary incontinence. Hispanics (83.8%) were more frequently bothered by their urinary incontinence than Whites (46.9%), Blacks (53%), Chinese (32.3%), and Japanese (50%) sufferers. Hispanics remained 5.7 times more likely to be bothered by their urinary incontinence than Whites after adjusting for severity and symptom duration [Sampsel 2002].

Women are negatively affected by urinary incontinence regardless of ethnicity. Ethnic differences in incontinence rates or types may be explained by selection bias when study samples are selected from tertiary care populations. Selection bias is introduced when ethnic differences in access to incontinence care are ignored. Selection bias may be minimized by conducting well designed population based epidemiologic studies where incontinent women of all ethnic groups are sampled adjusting for access to care differences.

Framing The Problem Of Understanding Incontinence Care Seeking Using Theoretical Modeling

Care seeking for urinary incontinence is a poorly understood health behavior. The process whereby incontinence sufferers simply adapt and manage their bladder control problem rather than seek treatment has been described as normalization. The rationale behind this normalization process is both complex and multi-dimensional. It is important to characterize this normalization process by identifying predictor variables in this “black box” that mediate the association of a symptom and its impact or a symptom and care seeking behavior in an ethnically heterogeneous incontinent female population. Figure 4 illustrates the lack of information (“Black Box”) that exists between symptom appraisal and impact or care seeking for symptoms.

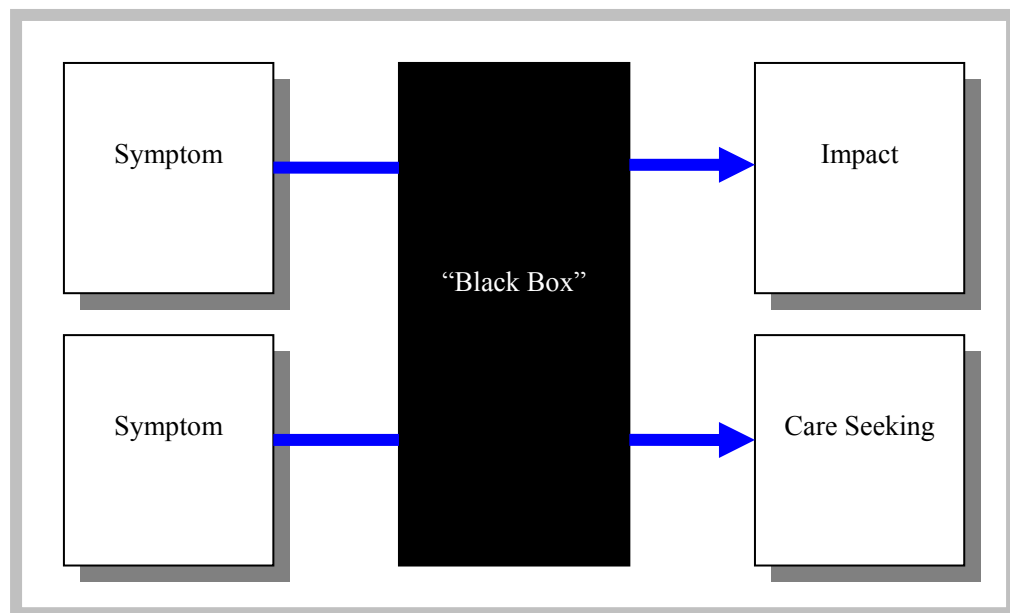

Figure 3. The knowledge gap (“Black Box”) between symptom appraisal and impact or care seeking for symptoms.

The identification of predictors of incontinence care seeking is an important precursor to the development of strategies aimed at modifying care seeking behaviors in an attempt to mitigate the negative quality of life, psychological, and public health impact associated with urinary incontinence. If clinicians and administrators understood women's reasons for, and barriers to incontinence care seeking it would contribute to their ability to bring symptomatic yet untreated individuals into the healthcare system earlier in the disease process at points where interventions might prevent higher levels of morbidity and loss of quality of life. Existing epidemiologic studies have established predictors of care seeking behavior for Whites. How these predictors apply to different ethnic groups is unknown.

The Theory of Reasoned Action and Triandis' Theory of Behavior have been frequently used to guide health related research. The benefit of using Triandis' Theory of Behavior to explain care seeking is that his theory is more comprehensive, more powerful, and more sensitive to differences among persons of differing socioeconomic status than the Theory of Reasoned Action. Variables from Triandis' Theory of Behavior have been shown to explain 33 to 66% of the variance in health behaviors or behavioral intentions such as mammography use and exercise [Lauver 1992a].

Based on Triandis' Theory of Behavior, Lauver developed the Theory of Care Seeking Behavior, which states that the probability of engaging in a health behavior is a function of psychosocial variables (affect, utility, habits and norms) and barrier variables regarding the behavior [Lauver 1992a].

The Theory of Care Seeking Behavior only differs from Triandis' Theory of Behavior by excluding physiologic arousal as a predictor variable for explaining health

behavior. Affect, which is included Lauver's Theory of Care Seeking Behavior, is assumed to be an indicator of arousal making arousal's inclusion unnecessary [Lauver 1992a].

According to the Theory of Care Seeking Behavior, psychosocial variables (affect, utility (expectations x values), norms and habits) may directly predict care seeking behavior. Alternatively, psychosocial variables can interact with barrier variables to predict care seeking behavior. Clinical and demographic variables such as age, ethnicity, and socioeconomic status do not predict care seeking because any influences of clinical and demographic factors are captured by the salient psychosocial and facilitating (barrier) variables more proximal to care seeking [Lauver 1992a].

The Theory of Care Seeking Behavior was chosen in lieu of alternative behavioral theories because it excluded clinical variables from predicting care seeking after controlling for psychosocial and barrier variables. This characteristic made the theory suitable for my research questions because variables such as age, duration, and severity of illness are not consistently associated with incontinence care seeking in the clinician's office.

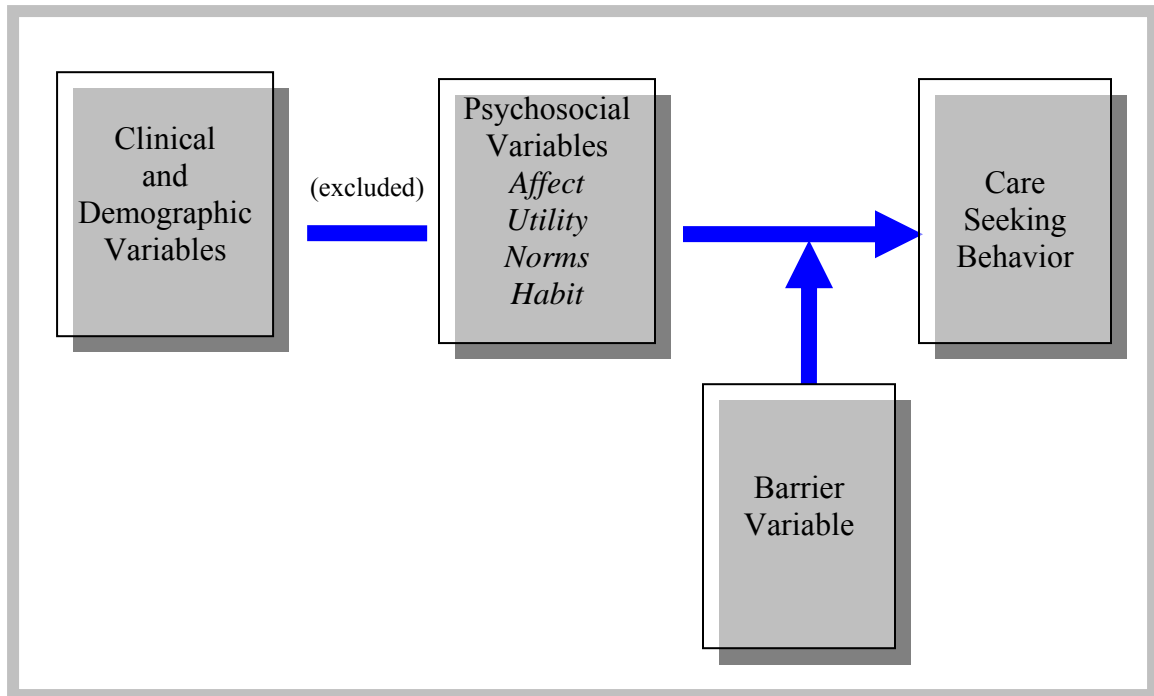

Figure 4. Lauver's Theory of Care Seeking Behavior

According to the Theory of Care Seeking Behavior, affect refers to feelings associated with care seeking such as anxiety about receiving a serious diagnosis, or embarrassment about an examination. No existing studies specifically address affect as a predictor of incontinence care seeking. However, reasons for not seeking incontinence care might include fear of surgery [Rekers 1992, Reymert 1994, Norton1998] and embarrassment over discussing symptoms with physicians [Reymert 1994, Norton 1998, Goldstein 1992, Rizk 1997].

Affective variables such as anxiety, fear, and embarrassment have predicted care seeking for other health related problems. In a study of women with breast cancer symptoms, anxiety was found to interact with having identified a health practitioner to explain care seeking for women with breast cancer symptoms [Lauver 1994]. For women without a practitioner, higher anxiety was associated with less delay. For women with a practitioner, the relationship between anxiety and care seeking was not significant.

Expectations refer to beliefs about the perceived likelihood of either good or bad outcomes from seeking care for a particular disorder. Beliefs about outcomes from care seeking are distinct from beliefs about the specific disorder in question. For example, expectations from care seeking differ from expectations about urinary incontinence. Value refers to the importance of each expectation from care seeking. Utility reflects the overall worth from care seeking and is measured as the sum of the products of each expectation and its corresponding value score. An association between utility beliefs and incontinence care seeking has not been studied. However, reasons for not seeking continence care include negative ideas about treatment possibilities [Rekers 1992], having the idea that other people could not help them [Rekers 1992, Reymert 1994], and low expectation of benefits from treatment [Holst 1988, Goldstein 1992, Rizk 1997]. Kinchen found that women who felt that a surgical treatment option was unacceptable were 32% less likely to seek incontinence care compared to women who found surgery acceptable. Women who were not embarrassed to talk with a physician about urinary incontinence were 65% more likely to seek incontinence care compared to women who were embarrassed. Finally women who thought that physician gender did not matter were 50% more likely to seek incontinence care compared to women in whom it mattered [Kinchen 2003].

A positive utility was found to have a significant association with an intention to seek care for breast cancer symptoms [Lauver 1992b]. In another study, asymptomatic women who saw greater utility for mammograms had greater intentions to seek mammograms as recommended [Lauver 1997].

Social norms reflects significant others' beliefs about care seeking. When significant others' beliefs about care seeking agree with ones' own belief, then health care is more likely to be sought. Burgio found that as the number of close friends with whom subjects felt at ease and could discuss private matters increased, the more likely they were to tell a doctor about their incontinence. Exchanging health information with friends also tended to be associated with reporting incontinence [Burgio 1994]. Kinchen found that women who talked with others about urinary incontinence were 234% more likely to seek incontinence care compared to women who did not talk with others about urinary incontinence [Kinchen 2003].

Incontinence sufferer's reasons for not seeking continence care included not wanting to talk about it, not knowing whom to talk to, and having the idea that other people could not help [Rekers 1992].

Women with stronger social norms about mammography were twice as likely to have a recent mammogram or intention to seek a mammogram compared to women with weaker social norms [Lauver 1997].

Habit refers to how one usually acts when one has symptoms, which reflects past experience with care seeking behavior. Burgio found three health habits associated with incontinence care seeking including: following a low fat diet, following a low salt diet, and having a smoke detector in the home. The importance of watching ones' weight was also related to incontinence care seeking. Patients who felt that regular physical exams were important were more likely to seek incontinence care. Patients who saw their physicians for annual physical exams were 2.5 times more likely to report incontinence than patients who saw their physicians less than every three years. Burgio suggested that

this effect may be explained by more contact with health care providers who may inquire about specific conditions, increased contact and familiarity with providers who make patients more comfortable discussing incontinence, or having more natural opportunities to discuss one's problems [Burgio 1994]. Kinchen found that women who kept regular appointments for routine/preventive care were 125% more likely to seek incontinence care compared to women who did not keep regular appointments. Women who made 3-5 physician visits over the last year were 26% more likely to seek incontinence care compared to women who made ≤ 2 physician visits over that same year. Women who made >5 physician visits over the last year were 66% more likely to seek incontinence care compared to women who made ≤ 2 physician visits over that same year. They found that women who put off going to see a physician until they absolutely had to, were 29% less likely to seek incontinence care than women who did not put off going to see a physician [Kinchen 2003].

Habit was associated with intention to seek care and promptness of actual care seeking for breast cancer symptoms [Lauver 1994, 1992b]. Women with preventive habits had 4.8 times greater odds of adhering to mammogram recommendations than women without such habits. Women with preventive habits had twice the odds of having a recent mammogram than those without such habits. They were also more likely to intend to seek mammograms as recommended [Lauver 1997].

Finally, facilitators are specific, objective, external conditions that enable one to seek care. Facilitating conditions are opposite to barriers that prevent care seeking. Therefore, low scores on measures of facilitating conditions may reflect barriers to care and vice versa [Lauver 1992a]. Barriers therefore, differ from internal conditions that

prevent one from seeking care such as inquisitiveness, or embarrassment, etc. Jacobsen found that men without health insurance were as likely to have sought medical care for urinary symptoms compared to men with insurance [Jacobsen 1993]. Burgio found no association between health care seeking for incontinence and distance from the health care provider measured in miles [Burgio 1994]. According to female incontinence sufferers, reasons for not consulting a doctor included not knowing a doctor well enough [Reymert 1994], worry about costs [Goldstein 1992], and male physician gender [Rizk 1997].

Barrier variables have been associated with care seeking directly and in interaction with psychosocial variables. Identifying a health care practitioner who they usually saw for health problems interacted with anxiety to explain care seeking for breast cancer symptoms. For women without a practitioner, higher anxiety was associated with less delay. For women with a practitioner, anxiety was not associated with care seeking [Lauver 1994].

Lauver's Theory of Care Seeking Behavior has provided the framework for studying whether the influences of psychosocial (affect, utility, norm and habit) and barrier variables on care seeking are conditional upon ethnicity. After controlling for education, financial coverage for healthcare, and family history of breast disease, utility and habit were positively related to intentions to seek care for breast cancer symptoms. Psychosocial variables alone were responsible for explaining 34% of the variance in care seeking behavior.

Interactions of both utility and norms with race, significantly explained intention to seek care for breast cancer symptoms, yet only increased the explanatory variance in

the model by 4%. The positive influence of utility on intention to seek care for breast cancer symptoms was stronger for Whites than Blacks while the positive influence of social norms was significant only for Whites [Lauver 1992b].

In a second study, utility and habit explained care seeking directly, and accounted for 10% of the explanatory variance in care seeking behavior. Habit was associated with promptness, while utility beliefs were associated with delay in care seeking. Adding an interaction term (anxiety * identified practitioner) explained an additional 6% of the variance in care seeking behavior. After adjusting for psychosocial and barrier variables, optimism and having a friend with breast cancer explained an additional 8% of the variance in care seeking behavior. Ethnicity had neither direct nor interactive effects on care seeking, after adjusting for these explanatory variables [Lauver 1994].

In summary, Lauver's Theory of Care Seeking Behavior can provide the theoretical framework for establishing predictors of incontinence care seeking in a ethnically heterogeneous incontinent female population. According to Lauver, psychosocial and barrier variables should explain any significant association between ethnicity and care seeking for a particular disorder, narrowing the study of predictors to modifiable variables. By studying modifiable variables like psychosocial and barrier variables I expected to identify specific areas where modifiers, in the form of educational programs, may increase the percentage of women who seek care for incontinence.

Clinical and Demographic Predictors of Incontinence Care Seeking from the Medical Literature

Hannestad [2000] surveyed 6,625 incontinent women from the Norwegian County of Nord-Trondelag to assess the proportion of women who visited their doctor because of urinary leakage and to find factors independently associated with help seeking. One thousand seven hundred and forty five of the 6,625 (26%) incontinent women surveyed, reported seeing a doctor for their incontinence. Increasing age, increasing symptom severity, increasing impact of incontinence, increasing duration of disease, urinary incontinence type (urge/mixed vs. stress incontinence), and visiting a generalist in the last 2 months were all independently associated with visiting a doctor because of their symptoms.

Although incontinent women with more severe and bothersome symptoms were more likely to seek help, still only 50% of women with “significant incontinence” (defined as women with moderate or severe incontinence who stated their symptoms were “bothersome”) had visited a doctor.

Admittedly, the authors did not fill my “black box” (Figure 3) with cultural or psychosocial predictors that may have provided a more complete picture of why incontinent women do not seek help independent of symptom severity and impact. Furthermore, the external validity of their findings to a United States population of incontinent women is limited, because of their homogeneous population of White women and the universal healthcare provided to Norwegian citizens through their national health service [Hannestad 2000].

Epidemiologic studies have established age as a predictor of incontinence care seeking [Jacobsen 1993 & 1995, Burgio 1994, Rekers 1992, Brocklehurst 1993, Holst 1988, Norton 1998, and Malmsten 1997]. Jacobsen found that the proportion of men seeking medical attention for urinary symptoms increased dramatically with age in a linear fashion. Age greater than 70 was associated with care seeking for urinary symptoms (OR 4.6, 95% CI 2.1,10.1), after controlling for all potential confounders [Jacobsen 1993]. In a similar study, Jacobsen found that men age 65 years and older were 2.7 times more likely to have sought care for urinary symptoms in the past year than men less than 65 years of age (95% CI 1.1,6.6). Age > 65 was still associated with care seeking for urinary symptoms, after controlling for all potential confounding factors. (OR 1.4, 95% CI 0.5,3.8) [Jacobsen 1995]. Holst found a similar relationship between age and care seeking for incontinence in women. He found women in the 25 – 34 year age group were less likely to seek help than women in the 75+ year age group who were more likely to seek help [Holst 1985].

Other studies have found a negative correlation between age and incontinence care seeking. Rekers found that advancing age was inversely related to consultation with a physician. He found that women aged 35 – 49, 50 –64, and 65 – 79 sought care 34, 25, and 24% of the time, respectively [Rekers 1992]. Burgio found that older individuals were less likely to inform their physician of their problem, after controlling for confounders [Burgio 1994]. Norton found that elderly women comprised the highest proportion of individuals who delayed treatment more than five years [Norton 1988].

Epidemiologic studies have also established symptom severity as a predictor of incontinence care seeking . Symptom severity is positively correlated with incontinence

care seeking [Roberts 1998, Jacobsen 1995, Burgio 1991 & 1994, Holst 1988, Roe 1999, Sandvik 1993, Lagace 1993, Rekers 1992]. Roberts found that moderate to severe incontinence was associated with having seen a physician for urinary symptoms in the previous year for men (OR 10.5, 95% CI 5.6,19.8) and women (OR 3.8, 95% CI 2.1,6.7) [Roberts 1998]. Jacobsen found that men with moderate to severe symptoms were more likely to have sought health care (OR 3.4, 95% CI 1.4,8.3). Men with moderate to severe symptoms were still more likely to have sought care (OR 2.8 95% CI 1.1, 7.2), after controlling for all potential confounding factors [Jacobsen 1995]. Burgio found that the frequency and volume of incontinent episodes were positively associated with incontinence care seeking in women. Patients with daily incontinent episodes were 2 times more likely to seek incontinence care compared to infrequent leakers (4/month), after controlling for all other potential confounders. Patients who wet their outer clothing with each incontinent episode were 1.7 times more likely to seek medical care compared to women who leaked a drop or two, after controlling for all potential confounding factors [Burgio 1994].

Jacobsen found that level of education was inversely related to care seeking for men with urinary symptoms. [Jacobsen 1995]. Jacobsen found that the probability of having sought medical care was inversely related to income, in a linear fashion. Income less than \$15,000.00 was associated with care seeking for urinary symptoms (OR 1.7, 95% CI 0.8,3.6), after controlling for all potential confounders [Jacobsen 1993]. Burgio found no association between level of education, or level of income, and incontinence care seeking. Brocklehurst found that full time workers who identified incontinence as a problem were more likely to see a doctor than, retired or part time workers. [Brocklehurst

1993]. Norton found that employment status was not significantly associated with delay in incontinence care seeking [Norton 1988].

Haaglund surveyed 78 of 95 persistently incontinent community dwelling Swedish women who participated in a previous longitudinal investigation of the 4 year incidence rate of urinary incontinence and associated changes in quality of life between 1996 through 2000. The purpose of the study was to investigate the reasons why some women with long term urinary incontinence seek professional help whereas others do not. They also studied respondent's experiences and satisfactions with the health care services they received, and how women deal with their urinary incontinence. Only 20 (26%) of the persistently incontinent community dwelling women had sought professional help for their problem. Incontinence severity, as measured by the Sandvik's incontinence severity index was a predictor of incontinence care seeking. Only 20% of women who reported slight incontinence sought help compared to 80% of women who reported moderate or severe urinary incontinence. Yet incontinence severity was also associated with a desire for treatment in women with long-term urinary incontinence who had not sought professional help. Nineteen of 33 (58%) of women with long term moderate or severe urinary incontinence who had not sought professional help desired treatment because of their urinary incontinence compared to 14 of 33 (42%) of women with slight long term urinary incontinence. These findings provide support for my "black box" (Figure 3) between an affected individual's self-assessment of incontinence severity and health care seeking. Twenty-six of the 58 incontinent women responded "I don't know why I haven't sought help", to the open ended questions concerning reasons for not seeking professional help for urinary incontinence. Pelvic floor exercises, wearing protective

products, and maintaining an empty bladder were the 3 most common methods for managing urinary incontinence in the 58 women who did not seek professional help for their symptoms. Self efficacy or mastery over these self care strategies may allow sufferers to perceive of normalcy despite their condition and such cognitions may mediate the relationship between incontinence severity and incontinence care seeking in my “black box” [Haaglund 2003].

Yip conducted a telephone survey of 1500 Chinese women to determine the treatment seeking behavior of women with urinary symptoms. One hundred and ninety four (13%) of the 1500 surveyed Chinese women reported “involuntary loss of urine, which was either socially or hygienically unacceptable.” Of these 194 incontinent Chinese women, only 68 (35.1%) sought medical advice. Reasons for not seeking medical care included, symptoms not serious enough (94.4%), lack of knowledge that help was available (8.7%), and no time (3.2%). Older women were somewhat more likely to seek care for urinary symptoms, although the difference did not achieve statistical significance (57.3 ± 12.9 vs. 52.9 ± 15.1 , $p = 0.05$). Only symptoms of incomplete emptying were significantly associated with seeking medical advice [Yip 2003].

Seim conducted a mail survey of 1820 Norwegian women to investigate the consultation behavior and predictive factors of importance for this behavior [Seim 1996]. Five hundred and thirty five (29%) Norwegian women reported urinary incontinence and only 107 (20%) had consulted a doctor. An additional 98 (18%) planned consultation with a doctor for urinary incontinence symptoms. Increasing age, increasing duration, and urge or mixed urinary incontinence was predictive of consulting a physician for urinary

incontinence. Increasing symptom severity and increasing impact were predictive of intent to consult a physician for urinary incontinence. Incontinence severity alone did not explain consultation behavior completely. Less than half of the surveyed incontinent women with the highest scores on symptom severity or impact, consulted their doctor for symptoms [Seim 1996].

Psychosocial Predictors of Incontinence Care Seeking from the Medical Literature

Other previously studied and sometimes established predictors of incontinence care seeking include quality of life [Burgio 1994, Sandvik 1993], perceived mental and medical health [Burgio 1994, Lagro-Janssen 1990], health locus of control [Lagro Janssen 1990], socioeconomic status, level of education [Burgio 1994, Jacobsen 1995], income [Burgio 1994, Jacobsen 1993], and employment [Brocklehurst 1993, Norton 1998]. Burgio found that impairment in activities of daily living (ADLs), especially physical ADLs, was significantly associated with telling a doctor about incontinence ($p < 0.01$). Incontinent subjects with impairment in physical ADLs were 1.3 times more likely to report symptoms to a doctor compared to incontinent subjects without physical ADL impairments, after controlling for all potential confounding variables [Burgio 1994]. Similarly, Sandvik showed that incontinent subjects who had consulted a doctor reported more social restrictions than those who had not (45% vs. 33%) [Sandvik 1993].

When Lagro-Janssen compared 66 women with recognized incontinence to 140 women with unrecognized incontinence, he found no difference in sociodemographic background (age, marital status, parity, education), psychosocial characteristics (locus of control, social support), perceived health status, or the number of reported chronic diseases [Lagro-Janssen 1990].

Haaglund surveyed 1574 women in Sweden (787 incontinent, 787 continent) to compare the quality of life, as measured by the SF-36, in: 1) women with and without urinary incontinence in relation to age, 2) women with stress incontinence and women with urge incontinence, and 3) women who had consulted a health care service because of urinary incontinence symptoms versus women who had not consulted health care.

Quality of life was significantly lower for women with urinary incontinence than for women without urinary incontinence on all eight dimensions, after adjusting for age. Women with urge incontinence scored significantly lower on all SF-36 dimensions than women without urinary incontinence. Women with stress urinary incontinence had significantly lower scores on all eight SF-36 dimensions compared with women without urinary incontinence yet the absolute difference in score was smaller for women with stress incontinence compared to women with urge incontinence.

Women with urge incontinence were older than women with stress incontinence which may have confounded the relationship between urinary incontinence type and quality of life. This hypothesis was not tested using multivariable analysis in this study.

Only 14% of women with urinary incontinence had consulted health care services about their disorder. Incontinence type and impact on quality of life were both associated with consultation behavior in a predictable way. Women with urge incontinence reported greater frequency of consulting professional health care than did women with stress incontinence (41 vs. 10%).

Both quality of life and age may have confounded the relationship between incontinence type and consultation behavior because both these predictors co-vary with incontinence type and were also associated with consultation behavior. This hypothesis was not tested using multivariable analysis in this study. Women with urinary incontinence who had consulted a health care service scored significantly lower than women with incontinence who did not consult a health care service in seven out of eight quality of life dimensions after adjusting for age. Finally, women with urinary incontinence who received professional health care were older compared to women with

urinary incontinence who did not consult health care (54 ± 11.5 vs. 50 ± 11.4) [Haaglund 2001].

Locher surveyed 74 incontinent women who sought treatment at a multi-disciplinary continence program or volunteered for a randomized clinical trial of behavioral and drug therapy for incontinence [Locher 2002]. The purpose of Locher's study was to assess the effects of age and patient's attribution of incontinence to aging (incontinence beliefs) on health care decisions including self-management continence strategies, self-treatment (Kegel) continence strategies, or seeking formal treatment from a health care provider. The attribution of incontinence to aging was associated with decreased number of self management strategies, increased self-treatment (Kegel) continence strategies, and a trend towards decreased formal treatment from a health care provider. Older age, alone, was associated with fewer self management continence strategies, not the adoption of self treatment (Kegel) continence strategies, or formal treatment from a health care provider. The impact of urinary incontinence on activities of daily living overwhelmed both age and attribution of incontinence to aging as predictors of self management strategies, when added to the model. Attribution of incontinence to aging remained an independent predictor of self treatment (Kegel) continence strategies, after adjusting for the impact of urinary incontinence on activities of daily living. However the impact of urinary incontinence on activities of daily living was a much stronger predictor of self treatment (Kegel) continence strategies than attribution to age (OR 11.45 vs. 7.13). The study group was unable to identify predictors of use of formal treatment from a health care provider. These findings are consistent with other studies that demonstrate impact of urinary incontinence on activities of daily living as the major

determinant of whether incontinent women choose any care at all, self care or formal treatment, otherwise.

The duration of symptoms was 5.4 years longer in the group of women who attributed their incontinence to the aging process compared to women who did not. This suggests that an individual's beliefs about the causal nature of their disorder may act as a barrier to adequate care, whether they choose self management continence strategies, self treatment continence strategies, or seek formal treatment from a health care provider. This study was likely to overestimate the effect of explanatory variables on disorder response because their study sample was generated from a sample of incontinent women who had already sought care for symptoms [Locher 2002].

Dugan surveyed 149 screened older adults who were not screened for urinary incontinence by their primary care physician. The purpose of this survey was to determine why older community-dwelling adults with urinary incontinence did not initiate a discussion with their doctor about their problem. In this study care seeking was defined as the initiation of a discussion about urinary incontinence with their primary care physicians. Only 46 (31%) of older adults who had not been asked about their problem, initiated a discussion about urinary incontinence with their primary care physician. "Not a big problem" (45%) and "normal part of aging" (19%) were the two most common reasons why 103 (69%) older adults with urinary incontinence who had not been asked about their problem, did not discuss the issue with their primary care provider. Embarrassment (3%) or lack of awareness of treatment option (2%) was infrequently cited as reasons for not initiating a discussion about urinary incontinence with their primary care physician. Younger age, increased frequency of incontinence

episodes per day, increased frequency of nocturia, increased impact of urinary incontinence on activities of daily living, disease specific quality of life impairment, and higher visit satisfaction were all associated with seeking help.

Older adults with 1.7 urinary incontinence episodes per day did not view urinary incontinence as abnormal or a medical condition warranting attention. This study likely overestimated the association between urinary incontinence beliefs and severity, with incontinence care seeking because survey respondents had visited their primary care physician within 60 days of the survey [Dugan 2001].

Barrier Predictors of Incontinence Care Seeking from the Medical Literature

Cognitive barriers such as lack of awareness, knowledge, or embarrassment have been established as independent predictors of incontinence care seeking. McGrother conducted a mail survey of 108 general practices in Leicestershire and Rutland counties, United Kingdom to establish the healthcare need and healthcare requirements of incontinent people aged ≥ 40 years. He received 92,491 responses for his prevalence study and (60.2% response rate) and 23,182 responses for his incidence and remission rate study (63% response rate). Eighty five and a half percent of their study sample was White.

In their study, healthcare need was defined as the sum of clinical storage disorders plus epidemiologically abnormal storage symptoms with impact on quality of life. Healthcare need represented the proportion of the sample population with symptoms who met the professionally defined thresholds for care. Felt need was defined as use of care from healthcare professionals by consultation or treatment or use of pads, aids, or catheter from any source or personal report of need for symptoms. Felt need represented the proportion of the sample population who met the personally defined thresholds for care. Healthcare requirement was defined as the overlap between healthcare need and felt need. Healthcare requirement represented the proportion of the sample population with a personally defined threshold for care who met the professionally defined thresholds for care. Unmet felt need was defined as the proportion of the sample population who reported a need for help because of storage symptoms.

Figure 5 illustrates the gaps between the age specific prevalence of storage symptoms and the needs of incontinent women in the United Kingdom.

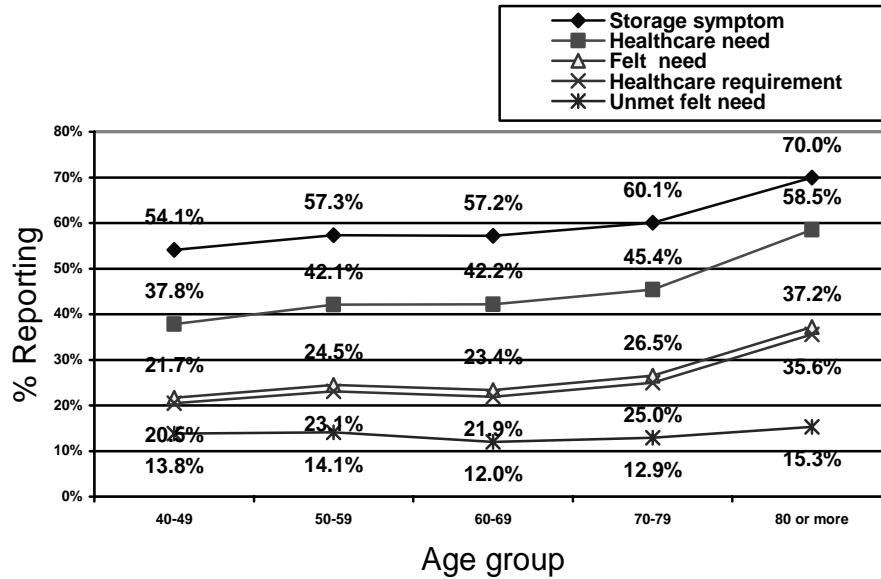

Figure 5. The health needs of incontinent women in the U.K.

Overall, 37.1% of the United Kingdom’s population aged ≥ 40 years (9 million people) had a healthcare need because of storage symptoms. Twenty and four tenths percent of the population aged ≥ 40 years (5 million people) had a healthcare requirement because their felt need met the professionally defined thresholds for care including 12.1% of the population aged ≥ 40 years (3 million people) with unmet needs.

The study group identified factors associated with unmet felt need and help seeking in an attempt to explain the shortfall between healthcare need and health care requirements. Male gender (OR 1.52 95% CI 1.41, 1.61), increasing age (OR 1.22–1.9), symptom severity (OR 1.11 95% CI 1.09, 1.12) and increasing quality of life impact (OR

5.3→18.9) were all independently associated with care seeking. Male gender (OR 1.47, 95% CI 1.43, 1.47) and younger people (OR 1.18-2.78) were more likely to feel an unmet need for help after controlling for symptom severity and quality of life impact. The authors concluded from both qualitative and quantitative analysis that the gap between healthcare need and requirement could be explained by a lack of awareness or knowledge for women and older people who fail to attribute symptoms to pathologic causes or feel no treatment alternatives to surgery were available. The external validity of their findings was limited because their study was conducted in the United Kingdom which provides universal healthcare to its citizens through their National Health Service, and their sample population was primarily white. Given the fact that all the citizens of the United Kingdom have universal healthcare they likely overestimated the relationships between predictors and care seeking [McGrother 2004].

Kinchen surveyed a random sample of 45,000 U.S. households that volunteered to participate in survey projects conducted by the National Family Opinion Workgroup to identify women with urinary incontinence. The purpose of this survey was to characterize incontinent women of all ages who were treatment seekers and to compare them with incontinent women who were not treatment seekers. One thousand nine hundred and seventy of 2310 incontinent respondents (85.3% response rate) were asked if they had ever talked with a physician about leakage or involuntary loss of urine. Respondents who answered no were considered nonseekers. Ninety percent of the study sample was self designated as White. Thirty eight percent of respondents were categorized as treatment seekers.

Age greater than 60 (OR 1.61 95% CI 1.16, 2.24), frequency of physician visits greater than five per year (OR 1.66 95% CI 1.20, 2.31), urinary incontinence duration three years or more (OR 2.33, 95% CI 1.57, 3.45), history of noticeable accidents (OR 1.41, 95% CI 1.06, 1.87), severe incontinence (OR 4.13, 95% CI 1.35, 12.59), and higher impact of urinary incontinence on quality of life (scores <80, OR 1.89, 95% CI 1.32, 2.70; scores 80-89, OR 1.39, 95% CI 1.05, 2.04) were independent predictors of treatment seeking. Additionally several respondent attitudes were independently associated with treatment seeking after controlling for the previously mentioned clinical and sociodemographic variables. Respondents who felt that a surgical option was less acceptable (OR 0.68, 95% CI 0.53, 0.88), or who put off going to see a physician until they absolutely had to (OR 0.71 95% CI 0.54, 0.93) were less likely to seek treatment. Respondents who were not embarrassed about talking with a physician about urinary incontinence (OR 1.65 95% CI 1.28, 2.14), who felt that gender of physician did not matter (OR 1.50, 95% CI 1.16, 1.92), who talked with others about urinary incontinence (OR 3.34, 95% CI 2.49, 4.49), who scheduled regular appointments for routine/preventive care (OR 2.25, 95% CI 1.54, 3.29), or who were likely to seek information about medical conditions of concern (OR 1.43, 95% CI 1.08, 1.90), were more likely to seek treatment [Kinchen 2003].

Defining treatment seekers as those respondents who had talked to a physician about urinary incontinence may have underestimated the help seeking behaviors of incontinent women because many seek care from alternative healthcare providers such as physiatrists, or nurse practitioners. The external validity of their findings was limited because their sample population was primarily White.

Overt barriers, defined as objective physical impediments have not been well studied in the incontinence care seeking literature.

Ethnicity and Incontinence Care Seeking from the Medical Literature

Prior to the present study, only one published study examined ethnicity as a potential predictor of incontinence care seeking [Sampselle 2002]. Sampselle found that only 12% of incontinent women had discussed their problem with a provider. Rates of incontinence care seeking differed by ethnicity. Chinese women (5.6%) and Hispanic women (7.8%) were less likely to discuss incontinence with a healthcare provider than White (13.7%), African-American (12.5%), and Japanese women (10.2%). However ethnicity was overwhelmed by increasing incontinence severity, increasing duration of urinary incontinence, and seeing a doctor within the past year in the multivariable analysis. After controlling for these variables in the model, ethnicity no longer predicted the likelihood of discussing leakage with a healthcare provider [Sampselle 2002].

According to the Theory of Care Seeking Behavior, psychosocial and barrier variables should explain the association between ethnicity and incontinence care seeking rather than other clinical or demographic variables. For psychosocial and barrier variables to explain (confound) the association between ethnicity and incontinence care seeking, they must differ across ethnic groups.

Socioeconomic status, access to care, and health locus of control differ across ethnic groups. Socioeconomically disadvantaged populations are disproportionately made up of minorities. In 1990, of the 13% of the United States population below the poverty level, 11% were Whites, 32% were Blacks, and 28% were Hispanics [Frank-Stromberg 1997]. Differences in socioeconomic status explain health disparities for the leading causes of death between Blacks and Whites. With sociodemographic controls in

place, most Blacks cause specific mortality rates approach those of Whites. They are less likely to die from accidents, respiratory diseases, and suicides, and as likely as Whites to die from circulatory disease and cancer [Rogers 1992].

Access to care as measured by health insurance coverage and identifiable source of ongoing care differ across certain populations. According to Healthy People 2010, among the nonelderly population, approximately 31% of Hispanic persons lacked coverage in 1997, a rate that is double the national average. For adults under age 65, 33% of those below the poverty level were uninsured. An average of 84% of adults identified a specific source of ongoing care in 1997, but the proportions dropped to 75% for Hispanics and 75% for those below the poverty level [Healthy People 2010, Conference Edition]. Based on qualitative data collected from a sample population of 203, Bailey found that Blacks utilize various self care regimens primarily because of the perceived absence of access to medical care and the cultural trait of individual moral strength. City dwelling Blacks from Detroit hold a negative attitude about the health care system that in turn leads to a tendency not to seek help or to delay help seeking. According to the U.S. Department of Health and Human Services, if health professionals recognize cultural variables as they apply to various ethnic groups, then health education programs can be tailored more carefully to the meet the needs of minorities [Bailey 1987].

Finally, health locus of control differs across ethnic groups and has been shown to be associated with health care utilization. South Asians had significantly higher internal, chance, and powerful other health locus of control than White Europeans and Afro Caribbeans. Wrightson and Wardle found an interaction between religion and health

locus of control for South Asians, after controlling for socioeconomic status. Among the more religious women, Asians still scored significantly higher on internal, chance, and powerful others, suggesting that other aspects of the cultural background play a role in healthcare utilization [Wrightson & Wardle 1997].

A recent National Hospital Ambulatory Medical Care Survey [Bazargan 1998] indicated that compared to their White counterparts, elderly Blacks display a higher rate of visits to emergency departments and outpatient clinics and lower rates of office based physician visits. Higher scores on internal, chance, and powerful other health locus of control scales, enabling characteristics (perceived tangible support, availability of medical doctors) and need characteristics (perceived health status, heart conditions, age problems) predicted emergency room utilization by elderly Blacks, after controlling for demographic variables. Higher scores on internal and powerful other health locus of control scales, enabling characteristics (private insurance) and need characteristics (heart conditions, cancer, and limitation of daily activities) predicted hospital admissions for elderly Blacks, after controlling for demographic variables. Demographic variables (sex, education, living alone), internal and powerful other health locus of control, enabling characteristics (perceived tangible support, availability/accessibility of medical doctors, having Medicaid or private insurance, or residential stability) and need characteristics (hypertension, arthritis, breathing problems, stomach, ear, teeth and blood circulation problems, stroke and cancer) predicted physician visits for elderly Blacks. Elderly Blacks with higher levels of education, who were male, and who lived alone, reported a greater number of physician visits.

According to Bazargan, their research identified health locus of control scales as the most important predictor of health care utilization by elderly Blacks. The identification of perceived accessibility and availability of medical services and health locus of control as influential determinants of health care utilization among elderly Blacks provides a basis for designing interventions to modify utilization behaviors within that community [Bazargan 1998].

A large proportion of Mexican Americans believe that disease and health are not under their control but at the will of the environment and God. When ill, Mexican Americans usually first consider remedies, prescribed by knowledgeable housewives or curanderas (folk curers). Typically, a folk curer is consulted only after the family's remedies have failed. Many Mexican Americans will accept modern medical attempts to alleviate or cure the disorder, only if their own methods have failed or the sick person is gravely ill and requires immediate treatment [Gonzalez-Swafford 1983]. By emphasizing diagnosis and cure, the medical model tends to ignore what is most important to the Mexican American patients and families; their own perception of what is wrong. It is this bias that often is responsible for client non-compliance, dissatisfaction with clinical care, and failure of treatment in the Mexican American community [Gonzalez-Swafford 1983].

The presence of a physician visit was found to be positively associated with the perception of abnormal bowel function, more time spent thinking about bowel function, and being White, after controlling for socioeconomic status. The odds of a physician visit for bowel problems were increased by a factor of 1.98 for individuals who were White compared to Hispanics. Hispanics reported spending more time attending to their bowel function than Whites. Herbs or herbal teas were taken more often to maintain good

bowel function and treat bowel problems by Hispanics than Whites. Zuckerman suggested that population-based studies that include United States Hispanic and other ethnic group respondents from a broader range of socioeconomic classes would be “worthwhile in helping to clarify determinants of health care behavior . . . , and be important for the analysis of public health implications, and resource allocation . . .” [Zuckerman 1996 page 81].

CHAPTER III

RESEARCH METHODOLOGY

Phase I – Adapting the Theory of Care Seeking Behavior for the Clinical Problem of Urinary Incontinence

Focus groups

The objectives of the focus groups were to develop an incontinence specific utility and barrier measurement tool, adapted to tap aspects of the Theory of Care Seeking Behavior for the clinical problem of urinary incontinence. Proponents of the Theory of Reasoned Action maintained that preliminary research is needed to develop valid measures of expectations and values that are salient to incontinence care seeking. If valid expectations were described and reliable measures of these expectations were developed, then the relationship of utility to actual incontinence care seeking could be examined more accurately [Lauver 1993]. Although barrier measurement tools exist, they have never been tested in an ethnically heterogeneous incontinent female population.

Sample

I conducted six focus groups to meet my objective. Ethnicity (non Hispanic Whites, non Hispanic Black, and Hispanic) was considered as the critical characteristic for stratifying my focus group respondents. I had planned to further stratify my focus groups by socioeconomic status to minimize the effect that socioeconomic status, rather

than ethnicity had on responses to questioning. However, it became difficult to stratify my ethnic focus groups by socioeconomic status because of the homogeneity of my sampling frame during phase I focus group recruitment. Therefore, my six focus groups were only stratified by self designated ethnicity.

A nonprobability purposive sample of 56 continent women (21 Whites, 17 Blacks, 18 Hispanics) between the ages of 35 and 80 were recruited to participate in my 6 phase I focus group sessions. Generalizing my findings to the United States population was not the objective of this study phase, which overcame the limitations of this sampling technique. It was important to recruit continent women for these focus groups because it minimized the effect of incontinence symptom severity on focus group responses. Because respondents were continent and therefore not seeking incontinence care, focus group respondents were asked to imagine that they had just developed a problem with uncontrollable urine leakage.

Recruitment

To meet the focus group cell requirements, the University of Louisville Survey Research Center subcontracted my work to a facility in the Oakland/San Francisco Bay Area of California. Margaret Yarborough & Associates, had their own phone bank database from which they recruited my focus group respondents. The database included English speaking women of all ethnicity groups aged 35 to 80 years, living in one of three counties in Northern California who volunteered to participate in survey research through advertisement, word of mouth, and sign-up in a shopping center. This database enabled me to contact a large number of candidates in a relatively short period of time at

a minimal cost. To obtain approximately 10 individuals for each focus group cell, they recruited 15 individuals, because I expected a 20 – 35% no show rate for committed respondents.

Telephone calls were made to invite potential respondents to the planned focus groups, and to inform them of the purpose, sponsor, date, time, and location of the focus group sessions. I also provided potential respondents with information on financial incentives (\$50.00), and number of meals and refreshments provided for focus group participation. A confirmation letter was mailed to accepting respondents detailing meeting specifics. Follow-up telephone calls were made to accepting respondents one to two days prior to their scheduled focus group.

Focus Group Demographics

The mean age of the 56 phase I focus group participants was 54.25 ± 10.76 (median 52.37, 95% CI 51.37, 57.13, range 38-77). The mean socioeconomic status scores [Green 1970] of the 56 phase I focus group participants was 35.08 ± 6.67 (median 35.8, 95% CI 33.29, 36.86). Thirty (53.6%) focus group participants were unmarried and 26 (46.4%) were married. Fourteen (25%) focus group participants were covered by government issued health insurance, 40 (71.4%) were covered by private health insurance, and 2 (3.6%) did not have health insurance coverage.

Procedure

Margaret Yarborough & Associates scheduled my 6 focus group sessions. A female moderator experienced in psychological interviewing techniques began the

sessions with an introduction that included a reference to the use of recording equipment to archive the proceedings, a brief overview of the subject matter to be covered, and an explanation of the discussion rules for my focus groups. The proceedings were monitored onsite by the principal investigator and qualitative sociologist behind a one-way mirror. The focus group facility provided video and audio taping equipment for archiving the proceedings. I submitted these video and audiotapes to a transcriptionist who created transcripts of the proceedings. The moderator asked all focus group respondents “to describe the expected outcomes, advantages, and disadvantages of seeking prompt incontinence care or adopting a wait and see approach when faced with symptoms.” Scripts were independently reviewed by the moderator, principal investigator, and the qualitative sociologist for commonly reported themes in response to focus group question. Each reported theme was independently ranked by the investigators to establish the salience of each theme for measuring the utility of incontinence care seeking (0 = not important and discarded, or 1 through 5 for least important to most important). Finally, a meeting of all investigators was convened to select the highest ranked themes that were subsequently categorized as good or bad outcomes of incontinence care seeking. From the phase I focus group sessions, questionnaires on the perceived likelihood of good or bad outcomes of incontinence care seeking (expectations) and the importance of that outcome (value) were developed. These questionnaires allowed me to measure the utility of incontinence care seeking for an ethnically heterogeneous incontinent female population.

I modified Melnyk’s Barrier Scale used in Lauer’s Theory of Care Seeking Behavior for the clinical problem of urinary incontinence by adding six questions based

on a review of reasons for not seeking incontinence care from the medical literature [Rekers 1992, Holst 1988, Sandvik 1993, Reymert 1994, Goldstein 1992, and Rizk 1997]. Phase I focus group respondents were also asked open ended questions by the moderator to identify any additional barriers which may prevent them from seeking incontinence care. Answers to these open ended questions were also subjected to a thematic analysis to further modify Melnyk's Barrier Scale used in Lauver's Theory of Care Seeking Behavior for the clinical problem of urinary incontinence.

At the completion of phase I, I had a survey instrument capable of measuring the incontinence specific predictor variables in the Theory of Care Seeking Behavior.

Phase II - Establishing the clarity, comprehensiveness and acceptability of the survey instrument capable of measuring the incontinence specific predictor variables in the Theory of Care Seeking Behavior

Focus groups

The objectives of these focus groups were to establish the clarity, comprehensiveness and acceptability of the survey instrument capable of measuring the incontinence specific predictor variables in the Theory of Care Seeking Behavior. The survey instrument was modified to improve its clarity, comprehensiveness and acceptability for an ethnically heterogeneous incontinent female population based on the suggestions from my phase II focus group respondents in preparation for my computer assisted telephone interview (CATI). I conducted six additional focus groups to meet the objectives of study phase II.

Sample

A nonprobability (purposive) sample of 72 incontinent women (24 Whites, 24 Blacks, 24 Hispanics) between the ages of 35 and 80 were recruited to participate in my 6 phase II focus group sessions. Generalizing my findings to the United States population was not the objective of this study phase as well, which overcomes the limitations of this sampling technique. It was important to recruit incontinent women for these focus groups because this sample population had to accept the final survey instrument before I recruited incontinent survey respondents for my computer assisted telephone interviews (CATI).

Recruitment

To meet the focus group cell requirements, the University of Louisville Survey Research Center again subcontracted my work to the Margaret Yarborough & Associates facility in the Oakland/San Francisco Bay Area of California. To obtain approximately 10 individuals for each focus group cell, they recruited 15 individuals from their same phone bank database, as I again expected a 20 – 35% no show rate for committed respondents.

Telephone calls were made to invite potential respondents to the planned focus groups, and to inform them of the purpose, sponsor, date, time, and location of the focus group sessions. I also provided potential respondents with information on financial incentives, and number of meals and refreshments provided for focus group participation. A confirmation letter was mailed to accepting respondents detailing meeting specifics. Follow-up telephone calls were made to accepting respondents one to two days prior to their scheduled focus group.

Focus Group Demographics

The mean age of the focus group participants was 56.20 ± 12.33 (median 55.42, 95% CI 53.31, 59.10, range 39-84). The mean socioeconomic status score [Green 1970] for the 72 focus group participants was 34.38 ± 6.85 (median 35.2, 95% CI 32.77, 35.99). Thirty one (43.1%) focus group participants were married and 41 (56.9%) were unmarried. Eleven (15.3%) focus group participants were covered by government issued health insurance, 54 (75%) were covered by private issued health insurance, and 7 (9.7%) did not have health insurance coverage.

Procedure

Margaret Yarborough & Associates again scheduled my focus group sessions. Female telephone interviewers were trained on the survey instrument prior to survey administration in the following manner. All three investigators discussed the study objectives with an interview supervisor employed by Margaret Yarborough & Associates. All questions that made up my survey instrument were reviewed with the interview supervisor to clarify how each question related to my study objectives. Any additional questions about the survey instrument were answered to the satisfaction of the interview supervisor before she trained each female interviewer on the same survey instrument. Trained female telephone interviewers administered my survey instrument to consenting focus group respondents, one day prior to my phase II focus group sessions.

One day following survey administration, the same phase I female moderator , began my phase II focus group sessions, with an introduction including a reference to the use of recording equipment to archive the proceedings, a brief overview of the subject matter to be covered, and an explanation of the discussion rules, to my surveyed phase II focus group respondents. The focus group facility provided video and audio taping equipment for archiving the proceedings. The proceedings were monitored onsite by the principal investigator and qualitative sociologist behind a one-way mirror.

The focus group moderator and the two investigators modified my survey instrument to improve its clarity, comprehensiveness and acceptability for an ethnically racially heterogeneous female population in preparation for my computer assisted telephone interviews (CATI). I modified and adapted the entire survey instrument to socioeconomically disadvantaged (SED) populations because I planned to test the

hypotheses that ethnicity was an independent predictor of incontinence care seeking. SED disadvantaged populations are disproportionately made up of minorities and of persons with limited social experiences. Research has shown that SED study respondents may have impaired language skills, including a limited vocabulary, which can limit their viewpoint on their own personal experience. They may not comprehend the rationale for some questions. SED respondents may have difficulty categorizing data, may not be capable of distinguishing between nuances of terms or distinguishing between spectrums of options. Each of these areas of difficulty could have jeopardized the reliability of my survey instrument. I overcame these limitations by reducing the survey's literacy level, making individual word changes, and widening the response options, based on phase II focus group responses [Frank-Stromberg 1997].

Patterned responses, (automatic, unidirectional set of responses) and fatigue or disinterest can also jeopardize the validity and reliability of any survey instrument. I adapted different approaches to minimize the risk of patterned responses, such as randomly changing the order of fixed responses from question to question, and using questions that vary substantially in terms of wording or length. I limited my survey to thirty five minutes for fear of jeopardizing my response rate because of a reluctance to complete the instrument.

SED respondents have a greater tendency to respond to questions with socially desirable answers. The validity of my results may have been jeopardized if respondents unreliably stated that they had sought incontinence care after admitting that they had uncontrollable urine leakage because it was the socially acceptable thing to do. I directed the focus of my survey instrument away from the decision to use health care [Cameron

1993], and separated measures of predictor variables in the Theory of Care Seeking Behavior from measures of care seeking to maximize the validity of my results [Lauver 1994]. Questions on my survey instrument were asked in the following order: 1) questions involving personal reflections with similar response options (4 and 5 point Likert scale responses). The purpose of these questions was to increase confidence with the survey based on the ease of responses; 2) clinically oriented questions such as the date of symptom onset, incontinence care seeking, healthcare habits, past medical history, and present symptoms, and 3) sensitive questions that were least likely to be influenced by other responses, such as demographic data.

At the completion of phase II, the survey instrument had been modified to improve its clarity, comprehensiveness and acceptability for an ethnically heterogeneous female population in preparation for my computer assisted telephone interviews (CATI). See Appendix 1.

Phase III – Use computer assisted telephone interviews (CATI) to establish predictors of incontinence care seeking for an ethnically heterogeneous female population, based on the Theory of Care Seeking Behavior

Sample

I recruited a nonprobability (purposive) sample of ethnically heterogeneous United States community dwelling incontinent women aged 35 – 80 that were, a priori, stratified for socioeconomic status scores (High SES >30, Low SES <30) [Green 1970]. This stratification plan allowed me to control for socioeconomic status when bivariate associations between ethnicity and incontinence care seeking were explored. In fact, confounding of socioeconomic status was minimized for all comparisons between ethnicity and any other study variable collected during the study period. Nonetheless, my sampling methodology did not preclude the analysis of socioeconomic status as an independent predictor of incontinence care seeking or any other study variable collected during the study period.

The bulk of my study sample was recruited using random digit dialing. Phone numbers were purchased from a company that generates random digit dialing numbers by computers using information on working area codes and exchanges. These random digit dialing numbers were then screened to eliminate business numbers (determined by their appearance in business directories), and to eliminate not-in-service numbers (determined by computer dialing and testing of each number). The Hispanic sample was recruited from a national sample of listed telephone numbers for households with Spanish surnames (Survey Sampling International, Fairfield, CT).

The interview supervisor from the Survey Research Center provided trained female interviewers with these purchased lists of telephone numbers to contact potential study candidates by phone in the early evening (6:00PM to 9:00PM) and on the weekends (noon to 9:00PM). These times provided interviewers with greater opportunities to reach working adult household members. An institutional review board approved preamble (see Appendix 1) was read to all potential study candidates that identified the researchers conducting the study, introduced the purpose of the study, provided an estimate of the time required to complete the survey, provided confidentiality assurances, and obtained informed consent.

Recruitment

A single staged recruitment effort was used to recruit my sample of survey respondents. After obtaining informed consent, the trained female interviewers asked a screening question to determine if the candidate met one inclusion criterion for survey participation. The single inclusion criterion for my survey was based on Diokno's definition of urinary incontinence as any uncontrolled urine loss in the prior 12 months without regard to severity, in their epidemiologic survey [Diokno 1986]. For the purpose of my study, potential survey respondents were asked, "have you experienced uncontrollable urine leakage over the past 12 months". Candidates who responded affirmatively were considered incontinent, and asked to participate. Contacts who responded negatively were thanked for their time and excluded from participation in my survey.

Enhanced response rate efforts were employed to limit the time required to obtain the sample sizes needed for the study. If the interviewer encountered a busy signal, they called again in thirty minutes. If the line was busy, the call was placed again the next day. If the call the next day was busy, the interviewer called again in thirty minutes. If the line was still busy, the interviewer tried calling again on another day at a completely different time from the previous attempts. If the line was still busy the telephone number was classified as a nonresponse. Recruitment continued until my total sample size requirements and SES adjusted ethnicity cell sizes had been met.

Sample size

By choosing a confidence interval of 95%, I needed a minimum total sample size of 196 incontinent women to obtain a 7% margin of error around my sample estimates for each predictor variable in the Theory of Care Seeking Behavior [Rea 1997]. To fill each cell with an equal number of study respondents, it was necessary to over sample within the Black, and Hispanic stratum. To maintain my minimum sample size of 196 respondents, I reduced the number of Whites sampled accordingly. According to the Survey Research Center, adequate funding was available to recruit 275 survey respondents for this study. Table 2 demonstrates the ethnic breakdown of my 275 survey respondents.

Table 2
Disproportionate Sample Size Requirements For My Computer Assisted Telephone Interviews

Ethnicity	% of Pop	Proportionate Sample Size	SES Stratum	Proportionate Sample Size	Disproportionate Sample Size	Actual Sample Size
White	73%	175	Low	87	40	55
			High	88	40	45
Black	12%	29	Low	16	40	51
			High	13	40	44
Hispanic	12%	29	Low	16	40	40
			High	13	40	40
Other	3%	7	Low	5	0	0
			High	2	0	0
Total	100%	240		240	240	275

Procedures

At the Survey Research Center, trained female interviewers used 12 computer assisted telephone interview (CATI) stations to collect survey data. Compared to hard copy telephone interviewing, computer assisted telephone interviewing had several advantages that were important for phase III of my survey. These included facilitation of complex question branching, random assignment of interviewers to telephone numbers that reduced interviewer bias, randomization of the location or sequence of selected questions that eliminated any order effects, immediate identification of invalid responses, on-line monitoring of interviews by supervisors, and immediate conversion of completed interviews into raw data files [Harlow 1985, Marcus 1987].

Three strategies (commitment, instructions, and feedback) developed by the University of Michigan were used to minimize underreporting in my telephone surveys. These strategies were found to increase reports of acute and chronic symptoms, bed days, work-loss days, restricted activity, and physician visits [Marcus 1986].

1. Commitment – In my questionnaire preamble, I asked contacts to verbally commit to a pledge for hard work during the interview [see Appendix 1].
2. Instructions – In my questionnaire preamble, I provided improved instructions explaining what was expected, and how respondents were expected to produce complete and accurate answers to survey questioning.
3. Feedback – Using a script to standardize feedback, interviewers were trained to systematically reinforce positive, and discourage use of negative or non-task oriented respondent behavior.

Survey Instrument

A post hoc missing data analysis was conducted after the completion of study phase III when data from all 275 survey respondents was collected. The results of this missing data analysis is presented in this research methodology chapter rather than the results chapter to provide the readership with a complete description of the magnitude, impact, and imputation techniques used to handle missing data from a methodologic standpoint.

Table 3
Variables Captured by Survey Instrument

Dependent Variables in the Survey Instrument

- Incontinence Care Seeking

Independent Variables in the Survey Instrument

Psychosocial variables

- Affect variable
- Utility variable
- Norms variable
- Habit variable

Clinical and Demographic Variables

- Preventive Health Behaviors
 - Physical Exam Frequency
 - Incontinence severity
 - Health locus of control
 - Socioeconomic status
 - Impact of urinary incontinence on activities of daily living
 - Ethnicity
 - Symptom change
 - Marital status
 - Symptom duration
 - Age
-

-
- UI is a medical problem
 - Close relatives or friend with urinary incontinence
 - Pads per day
 - Incontinence type
 - Health insurance

Barrier Variable

Dependent Variables in the Survey Instrument

Incontinence Care Seeking

Incontinence care seeking was my dependent variable of interest and was determined as follows. Focus group respondents were asked if they had “sought care for uncontrollable urine leakage in the past 12 months.” According to Cleary, the validity of self reported physician utilization is acceptable. In their study, the average difference between reported and actual utilization in the previous year was only 0.05 visits.

Advancing age, frequent medical utilization, and membership in a prepaid health insurance plan were related to underreporting, while belief in regular checkups, health status, and demoralization were related to overreporting. They felt it was possible to generate accurate aggregate self-report utilization data provided that interviewers made every effort to reduce error by using detailed probes and memory aids [Cleary 1984].

Female interviewers were trained to ask survey respondents to relate care seeking episodes to important life events such as anniversaries, and holidays. Survey respondents

who respond affirmatively were considered to have sought care. I did not have any missing data for my dependent variable.

Independent Variables in the Survey Instrument (Theory of Care Seeking Behavior)

Psychosocial variables

Affect variable

For the purpose of this study, negative affect (10-items) and positive affect (10-items) was measured using the 20-item Positive and Negative Affect Schedule (PANAS). Positive Affect (PA) reflects the extent to which a person feels enthusiastic, active, and alert. Negative Affect (NA) reflects the extent to which a person feels anger, contempt, disgust, guilt, fear, and nervousness. Persons with negative affect are thought to demonstrate a subjective level of distress and unpleasurable experience exhibited in a variety of aversive mood states. Survey respondents were asked to respond on a 5-point Likert scale [1=very slightly or not at all, 2=a little, 3=moderately, 4=quite a bit, 5=extremely] to the question, “to what extent do you generally feel [insert emotion here]”. Existing research has shown that the test-retest reliability coefficients of the PANAS scale were stable over time and high enough ($0.47 \leq r \leq 0.68$) to suggest that the general ratings may be used as a measure of affective traits. The construct validity of the PANAS scales was established by correlating it with other measures of distress and psychopathology such as the Beck Depression Inventory ($r=0.74$), the Hopkins Symptom Checklist ($r=0.58$) and the State-Trait Anxiety Inventory’s (STAI) State Anxiety Scale ($r=0.51$). The advantage of the PANAS scales over the Beck Depression Inventory, and

the State-Trait Anxiety Inventory's (STAI) State Anxiety Scale is that the PANAS scales allow investigators to measure the two affective components [positive and negative] separately. Cronbach's alpha coefficients for the PA and NA scales were 0.86 and 0.87 respectively, and the correlations between the scales were -0.09 demonstrating the reliability and independence of the individual scales in an adult sample [Watson 1988].

Cronbach's alpha coefficients for the PA and NA scales in my sample population were 0.86 and 0.88, respectively, and the correlations between scales was -0.04. There was no missing data for 9 of the 20 questions making up the PANAS scale. For the remaining 11 questions, missing ordinal data accounted for only 0.4 – 2.5% of the 275 responses to the affect questions. Therefore, recoding missing ordinal data was expected to have little effect on the frequency distribution of my sample's affect score estimates. The small numbers of "don't know" and "refused answering" responses to the PANAS scale questions were considered "missing data" for the purpose of analysis. Missing data was recoded to the modal response for each of the 11 questions of the PANAS scale.

Utility variable

Two questionnaires on the perceived likelihood of good or bad outcomes of incontinence care seeking (expectations) and the importance of that outcome (value) were designed, based on my phase I focus group work. Survey respondents were asked to assess the likelihood (probability) of a specific outcome of incontinence care seeking from 0 (not at all likely) to 10 (definitely). Survey respondents were also asked to assess the importance of that specific outcome in their decision to seek incontinence care from 0 (no difference) to 10 (huge difference). The products of each matched expectation score

and corresponding value question score were summed and subsequently divided by the 12 questions posed to each respondent, to obtain a utility score for incontinence care seeking. The lower anchor score of 0 associated with “not at all likely” and “no difference” for the expectation and value questions respectively were recoded to a value of 1 so I could calculate a utility score. Recoding the lower anchor values eliminated the possibility that a low perceived likelihood of a good or bad outcome of incontinence care seeking (expectation score = 0 for “not at all likely”) or the low perceived importance of that good or bad outcome in making a decision to seek incontinence care (value score = 0 for “no difference”) would negate the matching likelihood or value of these perceptions for respondents.

The Cronbach’s alpha coefficients for the expectation and corresponding value questions ranged from 0.71 to 0.78 and 0.68 to 0.73, respectively, from a study designed to assess whether the influences of affect, utility, norm, and habit on intention to seek care for breast cancer symptoms were conditional upon race [Lauver 1992b].

Cronbach’s alpha coefficient for my final 12 item expectation questionnaire was 0.56 (Control subscale 0.82, internalized fear/anxiety subscale 0.53, and externalized fear/anxiety subscale 0.57). The final expectation questionnaire and its scoring can be found in appendix 2. Missing data accounted for 1.1 to 8% of the 275 responses to my expectation questionnaire. Therefore, recoding missing ordinal data was expected to have minimal affect on the frequency distribution of my sample’s expectation score estimates. “Refused to answer” and “don’t know” responses to my expectation questionnaire were considered “missing data” for the purpose of analysis. When data for the expectation and corresponding value question were both missing, the missing

expectation response was recoded to the modal response for that individual expectation question.

Missing data accounted for 1.1 to 6.6% of the 275 responses to my corresponding value questionnaire. Therefore recoding missing ordinal data was expected to have minimal affect on the frequency distribution of my sample's value score estimates. "Refused to answer" and "don't know" responses to the value questionnaire were also considered "missing data" for the purpose of analysis. Missing value data was calculated as the mean value score for respondents whose corresponding expectation scores were identical and corresponding value scores were known. Pattern matching imputation was used to recode missing value data to the modal response for that individual value question when corresponding expectations scores were known but unique to the frequency distribution of expectation scores.

When data for the expectation and corresponding value question were both missing, the missing value response was recoded to the modal response for that individual value question.

Norms variable

To measure social norms, survey respondents were asked to identify the people (i.e., female friend, spouse, male friend, mother, father, other female relative, doctor or nurse) with whom they typically discussed their incontinence symptoms with [significant others discussion question], and how necessary that significant other thought they should seek incontinence care [significant others necessity question]. Some survey respondents had not discussed their symptoms with one or all of the significant others available to

them. These respondents were asked their perception of how necessary that specific significant other thought they should seek care for incontinence right away. Evaluating an incontinent person's perceptions of social norms, prevented missing data for survey respondents who had not discussed their symptoms with significant others. Survey responses were scored on a Likert Scale ranging from 0 (not at all necessary) to 3 (extremely necessary). Mean social norm scores were calculated by adding the significant others necessity question score [actual or perceived] and dividing by the 5 significant others with whom they had discussed incontinence symptoms. The internal consistency coefficients of the social norm questions range from 0.84 to 0.88 [Lauver 1992b].

Cronbach's alpha coefficient for the social norm questions in my sample population was 0.70. Eighty two (29.8%) survey respondents had no husband or partner to discuss seeking care for uncontrollable urine leakage with. These 82 respondents were given a social norm score of 0 for the husband or partner question to calculate a mean social norm score. Therefore 82 respondents had their mean social norm scores divided by the remaining four significant others available to them while the remaining 193 respondents had their mean social norm scores divided by the 5 significant others available to them. Excluding the aforementioned missing data for husband/partner discussion question, missing data accounted for only 0.4 to 0.7% of the remaining 193 responses to the significant others question (mother, and female relative). Therefore recoding missing ordinal data was expected to have minimal effect on the frequency distribution of my sample's significant others discussion question responses. The 3 total "don't know" responses were considered "missing data" for the purpose of analysis.

Missing data was recoded to the modal response, in each case “No”, to the question if they discussed seeking care for uncontrollable urine leakage with their mother (n=2) or another female relative (n=1).

As expected, missing data still accounted for 9.9 to 12% of the 275 responses to each of the significant others necessity questions after combining actual beliefs with perceptions of a significant others beliefs about seeking care right away. This missing data included the 3 responses to the significant others discussion questions (recoded to “no”) who were then recoded to “don’t know” for the significant others necessity question. Therefore, recoding missing ordinal data to the significant others necessity question was expected to have a significant effect on the frequency distribution of my sample’s significant others necessity scores estimate. Pattern matching imputation was used to redistribute missing data on the significant others necessity question to correspond to the known frequency distribution of my sample’s significant others necessity scores estimate.

This imputation was expected to minimize the overall effect of missing data in the analysis of my sample’s mean social norm scores. For example, missing data for 20 actual or perceived necessity questions were redistributed in the following frequencies: 4 (20%) were recoded as 1 (not at all necessary), 3 (15%) were recoded as 2 (rarely necessary), and 10 (50%) were recoded as 3 (necessary), and 3 (15%) were recoded as 4 (extremely necessary).

Habit variable

Survey respondents were asked whether they usually sought care for general health symptoms, symptoms of depression, and symptoms of urinary tract infection including urinary urgency, frequency, and dysuria. Response options included: 1) did not seek care (value = 1), 2) wait to see if symptom persists then sought care (value = 2), or 3) sought care right away (value = 3). Reactions to depressive symptomatology were chosen as representative of habits and their ability to predict incontinence care seeking because, like urinary incontinence, some sufferers do not consider depression a medical condition requiring care. Reactions to urinary tract infection symptomatology were chosen as representative of habits and their ability to predict incontinence care seeking because, like urinary incontinence, this disorder is prevalent in women, treatable, rarely life threatening, and is a common transient cause of incontinence. To calculate a habit score, the values for the three responses were summated. Higher scores reflected a greater tendency to seek prompt symptomatic care.

Cronbach's alpha coefficient for the habit questionnaire was only 0.44 in my sample population. This result was not unexpected because care seeking habits likely differ depending on the disorder evaluated by survey respondents.

Missing data accounted for 6.5% of the 275 responses to the urinary tract infection habit question and 11.3% of the 275 responses to the depression habit question. There was no missing data for the general health symptom habit question. Recoding of missing urinary tract infection habit questions was expected to have minimal affect on the frequency distribution of the sample estimate. Eighteen respondents answered "don't know" in response to the urinary tract infection habit question which was considered

“missing data” for the purpose of analysis. Missing data for the urinary tract infection habit question was recoded to the modal response which was “seek care right away.” Recoding of missing depression habit data was expected to have a significant affect on the frequency distribution of the sample estimate. “Refused to answer” and “don’t know” responses to the depression habit question were considered “missing data” for the purpose of analysis.

Pattern matching imputation was used to redistribute missing data on the depression habit question to match the known frequency distribution of my sample’s depression habit question responses. This imputation was expected to minimize the overall effect of missing data in the analysis of depressive habit scores. Thirty one missing data cases were redistributed in the following frequencies: 9 (29%) were recoded as 1, 11 (35.5%) were recoded as 2, and 11 (35.5%) were recoded as 3.

Clinical and Sociodemographic Variables

I have grouped preventive health behaviors, physical exam frequency, and health locus of control variables with clinical and sociodemographic variables because the salience of these predictors should already be captured by psychosocial and barrier variables in the Theory of Care Seeking Behavior.

Preventive Health Behaviors

Because preventive health behaviors such as having a regular exercise program, following a low fat diet, low salt diet, watching your weight, or having a smoke detector in their home were found to predict incontinence care seeking [Burgio 1994], survey

respondents were asked how important it was for them to engage in such behaviors. They responded on a 4-point Likert Scale, 0 (not at all important) to 3 (extremely important) for all four preventive health behaviors. A preventive health behavior score was calculated by summing the response values for all four preventive health behaviors.

Cronbach's alpha coefficient for the preventive health questionnaire was 0.67 for my sample population.

Missing data accounted for only 0.4% of the 275 responses to following a low fat, low salt diet question. There was no additional missing data for the remaining preventive health behavior questions. Missing data was expected to have little effect on the frequency distribution of the sample estimate for the low fat, low salt diet preventive health question. Only one respondent answered "don't know" when asked if they followed a low fat, low salt diet so this response was considered "missing data" for the purpose of analysis. Missing data was recoded to the modal response for following the low fat, low salt diet preventive health question which was 2 (important).

Physical Exam Frequency

Focus group respondents were asked how frequently they are seen for physical exams because frequent physical exams predicted incontinence care seeking [Burgio 1994]. Response categories included 1) more than 3 years since last visit, 2) every 2 to 3 years, 3) annually, and 4) once per month. There was not missing data for the physical examination frequency question.

Incontinence severity

For the purpose of my study, symptom severity was measured by self report using a validated symptom severity score for epidemiologic study. Survey respondents were asked to characterize their urine leakage frequency as: 1 = less than once a month, 2 = a few times a month, 3 = a few times a week, and 4 = every day and/or night. They were also asked to report the amount of urine leakage per episode as: 1 = drops, 2 = small splashes, and 3 = more. The original incontinence severity index was calculated as the product of the frequency and the amount of urine leakage present with scores ranging from 1 – 12. The construct validity of this four-level severity index was established by comparison with pad weighing tests with a correlation coefficient of 0.54 [Sandvik 2000]. The original incontinence severity index was modified based on the frequency distribution of the sample estimate from a large population based survey of residents in the Trondelburg County of Norway [Hannested 2000]. The three Likert response categories for the amount of urine leakage were converted to two response categories which limited the total possible incontinence severity scores to 1 through 4, 6, and 8. Modified incontinence severity scores of 1 through 2 were considered minimal/mild urinary incontinence, 3-4 were considered moderate urinary incontinence, and 6 and 8 were considered severe urinary incontinence.

Missing data accounted for only 0.4 to 0.7% of the 275 responses to each of the two questions that made up the incontinence severity index. Therefore recoding missing ordinal data was expected to have little effect on the frequency distribution of my sample's incontinence severity score estimates. A total of three "don't know" responses to my 2 questions were considered missing data for the purpose of analysis. Missing data

was recoded to the modal response for each of the two questions making up the incontinence severity index.

Health locus of control variable

Health locus of control measures people's beliefs that their health is or is not determined by their behavior. Internal health locus of control assesses the extent to which individuals believe they are responsible for their health, can avoid behavior that increases the risk of disease, and they should play an active role in coping with their disorder. Chance health locus of control focuses on the extent to which a person believes their health or sickness is a function of external forces such as luck, accident, or good fortune. Powerful others health locus of control assesses the extent to which individuals believe that powerful others, particularly physicians, nurses and other health professionals are responsible for their health and disorders [Wallston and DeVellis 1978].

I established the health locus of control for each survey respondent participant by having them complete all three 6-item questionnaires. Six point Likert response categories ranged from strongly disagree to strongly agree as recommended by the authors of the scale. Internal, powerful others, and chance locus of control scores were calculated by summing the response category scores for each of the three 6-item questionnaires. Each scale has been shown to be internally consistent with Cronbach's alpha coefficients ranging from 0.830 to 0.859. Correlations in the predicted direction between health locus of control scores and health status provided evidence for their construct validity.

Missing data accounted for 0.4 to 2.9% of the 275 responses to each of the 18 total questions that made up all three 6-item questionnaires. Therefore recoding missing ordinal data was expected to have little affect on the frequency distribution of the three health locus of control scores. The 48 “don’t know” responses and the 2 “refusals” of the 275 responses to each of the 18 questions were considered “missing data” for the purpose of analysis. Missing data was recoded to the modal response for each of the six questions that made up each questionnaires. Cronbach’s alpha for the 18 health locus of control items in my population was 0.711.

Socioeconomic status variable

Occupation, and education data were combined to create a socioeconomic status score based on the method of Green [Green 1970] for the purpose of my survey. According to Green, the main purpose of socioeconomic status scores was to partition variance in health behavior explained by socioeconomic factors so that other contributing variables such as knowledge and attitudes could be analyzed independently. To optimize prediction of nine preventive health behaviors, Green created numerical scores for the highest education level attained by the female or male respondent, household income level, and occupation level of the main household wage earner. A socioeconomic status score was calculated using the following equations that were weighted differently for White and non-White survey respondents. [White SES = (0.59*education score) + (0.27*income score) + (0.25*occupation score), Non White SES = (0.36*education score) + (0.42*income score) + (0.25*occupation score)]. When sensitive data like household income level was unavailable, a two-factor socioeconomic index was calculated without a significant loss in predictive value.

I felt that income questions had a high probability of generating significant amounts of missing data, or were too sensitive leading to turned off survey respondents altogether. To eliminate this risk, I calculated a two-factor SES index for White and non-White survey respondents based on the following equations [White SES = (0.7*education score) + (0.4*occupation score), Non White SES = (0.5*education score) + (0.6*occupation score)].

Missing data accounted for 4.2% of the 275 responses to the occupation question that was required to calculate a SES score. Therefore recoding missing ordinal data was expected to have little affect on the frequency distribution of my sample's occupation score estimates. Missing occupation scores were imputed as the mean score for all respondents with the same education level as the individual with the missing occupation data. SES scores were then calculated as previously described.

Some respondents reported job descriptions that were not scored in Green's initial work which was published in 1970. Job descriptions not included in Green's initial work were assigned scores by an interview supervisor, guided by scores assigned to similar job descriptions included in Green's initial work. The interview supervisor was masked to the incontinence care seeking status of my survey respondents.

Impact of urinary incontinence on activities of daily living

The psychosocial impact of urinary incontinence on activities of daily living was assessed with the disease specific Incontinence Impact Questionnaire-short form (IIQ-7) [Uebersax 1995]. Cronbach's alpha coefficients for the physical activity, travel, social relationships and stress symptoms subscales were 0.87, 0.87, 0.90, and 0.90, respectively.

Criterion validity was established by comparing Incontinence Impact Questionnaire scores with number of reported incontinent episodes with correlation coefficients of 0.46.

Four-point Likert response categories ranging from 0 = not at all, to 3 = greatly were used for the 7-item questionnaire as recommended by the authors of the scale. Total IIQ-7 scores ranging from 0 to 100 were calculated as the product of the mean response category scores (sum of the 7 individual item scores divided by 7) and 33.3.

Missing data accounted for 0.4-0.7% of the 275 responses to each of the 7 items that made up the IIQ-7. Therefore recoding missing ordinal data was expected to have little effect on the frequency distribution of the sample estimate for each question or the total IIQ-7 score. The 4 “don’t know” responses of the 275 responses for each of the 7 questions were considered “missing data” for the purpose of the analysis. Missing data was recoded to the modal response for each of the 7 questions that made up the IIQ. Cronbach’s alpha coefficient for the seven item incontinence impact questionnaire in my population was 0.89.

Ethnicity

Women categorized their ethnicity in response to the following question: “which of the following ethnic groups do you consider yourself belonging to. Are you...” 1) White and not Hispanic (White), 2) Black and not Hispanic (Black), or 3) Hispanic. Survey respondents were not offered alternative ethnicity response categories because sampling was restricted to these three specific ethnic groups of incontinent women. However, women who categorized their ethnicity outside of these structured responses were categorized as 4) Other.

There was no missing data for the ethnicity variable. However the ethnicity of 5 incontinent survey respondents (1.8%) was categorized as “other,” as decided a priori (see Table 2). Recoding their ethnicity data was expected to have little effect on the frequency distribution of the sample estimate. Pattern matching computation was used to recode the ethnicity of these five respondents to White based on a comparison of the individual calculated SES scores of these five to the mean SES scores of my remaining three ethnicity response categories.

The colloquial term “Black and not Hispanic (Black),” White and not Hispanic (White),” and “Hispanic” was chosen to minimize the misclassification of Hispanic survey respondents who consider their “color” as “Black,” “White”, or otherwise. Throughout this text, the use of the term “Black” was favored over “African-American” to eliminate the presumption that all “Black” survey respondents were of African-American origin. The use of the term “White” was favored over “Caucasian” to correspond to the use of the term “Black” throughout this text.

Symptom change

Survey respondents were asked “How would you best describe your uncontrollable urine leakage now compared to when you first noticed it?” The nominal response categories included 1= better, 2=no change, and 3= worse. There was no missing data for this variable.

Marital status

Survey respondents were asked “What is your marital status?” The nominal response categories included 1= married, 2=single, 3= divorced, 4=widowed, and 5=other. Marital status was recoded to 1 = married or 0 = unmarried which included single, divorced, widow and other responses, to eliminate the positive skew of the frequency distribution. There was no missing data for this variable.

Symptom duration

Incontinence symptom duration was calculated as the difference in months, between the survey date and the date of incontinence symptom onset, based on recall. Mean and median imputation was used to compute the duration of symptoms in months and years for the 6 (4.4%) missing data points.

Age

Survey respondent age was calculated as the difference between survey date and reported date of birth in seconds which were converted to years. There was no missing data for this variable

UI is a medical problem

Survey respondents were asked if “ uncontrollable urine leakage was a medical problem?” Nominal response categories included 1=yes, 2=no, and 3=don’t know. There was no missing data for this variable.

Close relatives or friends with urinary incontinence

Survey respondents were asked if they had any close relatives or friends with uncontrollable urine leakage posed as two separate questions.

Missing data accounted for 7.6% of the 275 responses to the close relatives question and 8.4% of the 275 responses to the close friends question. Recoding of missing data for both questions was expected to have minimal affect on the frequency distribution of the sample estimate. 21 and 23 respondents answered “don’t know” in response to the close relatives and close friends questions which were considered “missing data” for the purpose of analysis. Pattern matching imputation was used to redistribute missing data from these two questions to match the known frequency distribution of my sample’s close relatives and close friends responses. The 21 cases of missing data for the close relatives question were redistributed in the following frequencies; 10 (47.6%) were recoded as yes, and 11 (52.4%) were recoded as no. The 23 cases of missing data for the close friends question were redistributed in the following frequencies; 9 (39.1%) were recoded as yes, and 14 (60.9%) were recoded as no.

Pads per day

Pad usage was assessed by asking survey respondents, “How many pads do you wear in a day to protect your clothes from your uncontrollable urine loss?”

Incontinence type

Survey respondents who responded “yes” to the question, “Do you lose urine during sudden physical exertion, lifting, coughing, or sneezing?” were considered stress

incontinent if in addition they responded “no” to the question “Do you experience such a strong and sudden urge to void that you leak before reaching the toilet?” Survey respondents who responded “no” to the first question, and “yes” to the second were considered “urge incontinent.” Patients who responded “yes” to both questions were considered “mixed incontinent.” These questions have been validated against urodynamic testing results in a large sample of incontinent women [Sandvik 1995]

There was no missing data for the incontinence type variable.

Health insurance coverage

Survey respondents were asked, “What type of primary medical insurance do you have? Responses to this open ended question were categorized as government (Medicare, Medicaid, or Military), private, or none, based on recommendations from the U.S. Census Bureau.

Barrier Variable

For the purpose of this study, barriers to incontinence care seeking were assessed using a modification of Melnyk’s Barriers Scale. This measurement tool was developed to operationalize the concept of barriers as the consumer’s perceptions of cost or obstacles to care [Melnyk 1990]. This scale has been used by Lauver to measure the barrier variable in the Theory of Care Seeking Behavior [Lauver 1994]. Melnyk’s Barrier Scale was modified for the clinical problem of urinary incontinence by adding 6 incontinence specific questions to the original scale based on a review of reasons for not seeking incontinence care in the medical literature [Rekers 1992, Holst 1988, Sandvik

1993, Reymert 1994, Goldstein 1992, and Rizk 1997]. Phase I focus group respondents were asked open ended questions to identify any additional barriers, which may have prevented them from seeking incontinence care. Questions were constructed from answers to these open ended questions with stems formatted to match the established structure of Melnyk's Barrier scale.

Barrier scale scores were calculated in the following manner. Survey respondents were asked to rate the extent that each specific barrier item prevented respondents from seeking care for uncontrollable urine leakage on a 4-point Likert scale ranging from 0 (none) to 3 (greatly). Higher barrier scores reflected more barriers to incontinence care seeking.

Total barrier scores were calculated as the sum of the intrinsic and extrinsic barrier subscale scores based on the 14 total barrier items selected by confirmatory factor analysis.

Intrinsic barrier scores were calculated as the sum of the fear and inconvenience subscale scores based on the 6 of the 14 barrier items selected by confirmatory analysis.

Extrinsic barrier scores were calculated as the sum of relationship, site-related, and cost subscale scores based on the 8 of the 14 barrier items selected by confirmatory factor analysis (see appendix 3).

Melynck's Barriers Scale had an internal consistency coefficient of 0.70 in a study comparing care seeking for breast cancer symptoms in White and Black Women [Lauver 1994].

Missing data accounted for only 0.4 to 0.7% of the 275 responses to each of the original 19 questions that composed the scale. Therefore, recoding missing interval data

was expected to have little affect on the frequency distribution of my sample's barrier scale score's estimate. A total of three "don't know" responses, and three "refused" responses to all 19 original questions were considered "missing data" for the purpose of analysis. Missing data was recoded to the modal response for each of the 19 original questions composing the Barriers to Incontinence Care Seeking Questionnaire (BICS-Q). In my study, the Cronbach's alpha coefficients for the final 14-item Barriers to Incontinence Care Seeking Questionnaire (BICS-Q) was 0.828 (Inconvenience subscale 0.79, Relationship subscale 0.68, Site-related subscale 0.69, cost subscale 0.71, and fear subscale 0.57).

After all the computer assisted telephone interviews (CATI) were completed, raw data files were imported into SPSS for Windows v10.0 (SPSS, Inc., Chicago, IL) for analysis.

Statistical Analysis

Establishing the Factor Validity of the Expectations of Incontinence Care Seeking Questionnaire (EICS-Q) and the Barriers to Incontinence Care Seeking Questionnaire (BICS-Q).

A principal components exploratory factor analysis (Varimax rotation) of data from all 275 survey respondents was performed to estimate the number of components (Eigenvalues > 1) required to explain approximately 50% of the variance for all 21 original expectation questionnaire items. A confirmatory factor analysis was conducted to establish the final structure of the expectation questionnaire and assess its fit in my

ethnically heterogeneous incontinent female population using AMOS v5.0 structural equation modeling software (Small Waters Corp., Chicago, IL).

The calculated Goodness-of-fit parameters for my measurement models included χ^2/df (CMIN/DF) which tested the null hypothesis that the factor loadings, factor variances/covariances, and error variances for my model are valid [Byrne 2000]. The minimally acceptable ratio for this test statistic is <3 [Kline 1998]. The goodness-of-fit index (GFI) and the AGFI, which takes into account the number of degrees of freedom in the hypothesized model, measures the relative amount of variance and covariance in the sample data explained by the hypothesized model. The minimally acceptable GFI and PGFI values are 0.90, and 0.50, respectively [Byrne 2000]. The comparative fit index (CFI) is a measure of the complete co-variation in the data, with minimally acceptable values of 0.95. The root mean square error of approximation (RMSEA) estimates the discrepancy between the sample covariance matrix of optimally chosen parameter values for the hypothesized model and the population covariance matrix if it were known [Byrne 2000]. Values ranging from 0.05 to 0.08 suggests reasonable fit, values ranging from 0.08 to 0.10 suggests mediocre fit, and values greater than 0.10 suggest poor fit. Ninety percent confidence estimates around the RMSEA were also provided by the probability of close fit (PCLOSE) which tested the null hypothesis that the RMSEA is less than 0.05 (“reasonable fit” in the population). The PCLOSE value should exceed 0.50. Finally, Hoelter’s critical N (CN) estimates a sample size that would be sufficient to yield an adequate model for my goodness-of-fit statistic (χ^2/df). Values greater than 200 for Hoelter’s 0.05 and 0.01 indexes are indicative of a model that adequately represents the sample data [Byrne 2000].

Cronbach's alpha coefficients were estimated to establish the internal consistency (reliability) of the final expectation questionnaire and its subscales.

A confirmatory factor analysis was conducted to confirm the established structure of Melnyk's Barrier Scale and assess its fit in my ethnically heterogeneous incontinent female population. This factor analysis determined if the six questions added to Melnyk's Barrier Scale based on a review of reasons for not seeking incontinence care from the medical literature [Rekers 1992, Holst 1988, Sandvik 1993, Reymert 1994, Goldstein 1992, and Rizk 1997] and responses to open ended questions asked of phase I focus group respondents were retained in my final measurement model. The fit of my Barriers to Incontinence Care Seeking Questionnaire (BICS-Q) was assessed with the same parameters used for my expectation questionnaire fit assessment.

Establishing Predictors Of Incontinence Care Seeking For An Ethnically Heterogeneous Incontinent Female Population As Guided By The Theory Of Care Seeking Behavior.

I used the categorization command in SPSS for Windows version 12.0 (SPSS, Inc, Chicago, IL) to create 3 category ordinal data from index scores for clinical and sociodemographic, psychosocial, and barrier interval data. SPSS attempts to create three equal groups representing the lowest (Group 1), middle (Group 2), and upper (Group 3) 33 percentile of index scores for each measured variable. Post hoc categorization of interval data was conducted after the completion of study phase III when data from all 275 survey respondents was collected.

Categorization of interval data was performed for the following reasons. First, I plan to use these categorizations, a priori, in my follow-up study when a sample

population representative of the United States population will be recruited using random digit dialing. Secondly, categorization of interval data makes it easier for the reader to compare data between incontinence care seeking studies despite the fact that some cut point categorizations are arbitrary when made during post processing data analysis. However I made attempts to assure that categorizations closely approximated what clinicians would expect to see in their own practice when managing urinary incontinent women. For example, number of pads worn per day was categorized into three groups representing no pads worn per day, 1-2 pads worn per day, or 3 or more pads worn per day. Finally, categorization of interval data helped transform the frequency distributions of some of my parameter estimates from extremely positively skewed to equally distributed. For example, the frequency distribution of total barrier scores was non-Gaussian with extremely positive skew. Total barrier scores were transformed from non-Gaussian interval data to ordinal data where 102 Group 1 respondents had scores of 0, 83 Group 2 respondents had mean scores of 2.76 ± 1.23 (median 3, 95% CI 2.49, 3.03, range 1-5), and 90 respondents had mean scores of 11.89 ± 6.25 (median 10, 95% CI 10.58, 13.20, range 6-36).

There was no information loss when my five hypotheses were tested using ordinal data compared to interval data during logistic regression analysis.

Hypothesis Testing

Hypothesis 1 - Psychosocial variables directly predict incontinence care seeking as guided by the Theory of Care Seeking Behavior. I entered psychosocial variables (affect,

utility, norms, and habits) from the Theory of Care Seeking Behavior into the first block of my hierarchal logistic regression equation, to accomplish this task.

Hypothesis 2 - The predictive value of psychosocial variables for incontinence care seeking are modified (interaction effect) by barrier variables as guided by the Theory of Care Seeking Behavior. I entered interaction terms of psychosocial and barrier variables (affect*barrier, utility*barrier, social norms*barrier, habits*barrier) in the second block of my hierarchal logistic regression equation, to accomplish this task.

Hypothesis 3 - Clinical and demographic variables, including ethnicity, do predict incontinence care seeking after adjusting for psychosocial, and barrier variables contrary to Theory of Care Seeking Behavior. Subjects who had sought incontinence care (dependent variable) were compared to those who had not, with respect to potential clinical and demographic predictors (independent variable) of incontinence care seeking external to the Theory of Care Seeking Behavior. During bivariate analysis, chi-square tests were performed to determine if there was an association between categorized ordinal data and incontinence care seeking. Clinical and demographic variables that had a bivariate association ($p < 0.1$) with incontinence care seeking were entered into the third block of my hierarchal logistic regression equation, to accomplish this task.

Hypothesis 4 - Clinical and demographic variables, excluding ethnicity, and psychosocial variables explain the significant association between ethnicity and incontinence care seeking.

I promoted all significant ($p < 0.1$) clinical and demographic predictors of incontinence care seeking, including ethnicity, from the third block to the first block of my parsimonious hierarchical logistic regression, to accomplish this task.

Hypothesis 5 - The predictive value of clinical and demographic variables, including ethnicity, and psychosocial variables for incontinence care seeking is modified (interaction effect) by barrier variables. Several interaction terms (psychosocial variables*barriers) and (significant previously established predictors*barriers) were entered into the second block of the same parsimonious hierarchical logistic regression equation.

CHAPTER IV

RESULTS

Survey Respondent Demographics

The mean age of the 275 survey respondents was 54.94 ± 12.32 (median 53, 95% CI 53.48, 56.40, range 35-85). One hundred incontinent women (36.4%) self-designated their ethnicity as White, 95 incontinent women (34.5%) self-designated themselves as Black, and 80 incontinent women (29.1%) self-designated themselves as Hispanic. One hundred and thirty one (47.6%) of the 275 surveyed incontinent women were married, 49 (17.8%) were single, 37 (13.5%) were divorced, 52 (18.9%) were widowed, and 6 (2.2%) were “other.” The mean socioeconomic score, for all survey respondents was 30.01 ± 8.87 (median 29.90 95% CI 29.95, 31.06). One hundred and two (37.1%) of the 275 survey respondents received government issued health insurance, 136 (49.5%) had private health insurance, and 37 (13.5%) reported having no health insurance coverage.

Eighteen (6.5%) of my survey respondents reported seeing a physician once a month, 199 (72.4%) reported seeing a physician annually, 35 (12.7%) reported seeing a physician every 2-3 years, and 23 (8.4%) reported seeing a physicians more than 3 years from their last visit or never.

Eighty two (29.8%) respondents were categorized as having “slight incontinence” (ISI scores of 1-2), 112 (40.7%) were categorized as having “moderate incontinence” (ISI

scores of 3-6), 46 (16.7%) were categorized as having “severe incontinence” (ISI scores 8-9), and 35 (12.7%) were categorized as having “very severe incontinence” (ISI scores 10-12), as originally described by Sandvik [Sandvik 2000]. Eighty seven (31.6%) respondents were categorized as having “mild incontinence” (ISI scores 1-2), 74 (26.9%) were categorized as having “moderate incontinence” (ISI scores 3-4), and 114 (41.5%) were categorized as having “severe incontinence” (ISI scores 6-8), as modified by Hannestad [Hannestad 2000].

The mean number of pads per day worn by respondents was 1.40 ± 1.96 (median 1.0, 95% CI 1.17, 1.64). The mean incontinence impact questionnaire scores (IIQ-7) for survey respondents was 16.31 ± 22.48 (median 4.76, 95% CI 13.64, 18.98, range 0-100).

The mean duration of urinary incontinence symptoms was 57.26 ± 82.39 months (median 24, 95% CI 47.48, 67.04). Sixty (21.8%) survey respondents reported that their incontinence symptoms had gotten better since its onset, 137 (49.8%) reported that their symptoms were unchanged, and 78 (28.4%) reported that their symptoms were worse since symptom onset. Eighty six (31.3%) survey respondents reported stress urinary incontinence, 168 (61.1%) reported mixed urinary incontinence, and 21 (7.6%) reported urge incontinence.

Two hundred and twenty five (81.18%) survey respondents felt that uncontrollable urine leakage was a medical problem compared to 36 (13.1%) survey respondents who felt uncontrollable urine leakage was not a medical problem and 14 (5.1%) of women who did not know. See Table 4.

Table 4
Survey Respondent Demographics

Variable		95% CI
Age	54.94 ± 12.32	53.48, 56.40
Ethnicity		
• White	100 (36.4%)	
• Black	95 (34.5%)	
• Hispanic	80 (29.1%)	
Marital Status		
• Married	131 (47.6%)	
• Unmarried	144 (52.4%)	
Socioeconomic Status Score	30.01 ± 8.87	29.95, 31.06
Physical Exam Frequency		
• > 3 yrs or Never	23 (8.4%)	
• Every 2-3 years	35 (12.7%)	
• Annually	199 (72.4%)	
• Once a Month	18 (6.5%)	

Urinary Incontinence Severity		
• Slight	82 (29.8%)	
• Moderate	112 (40.7%)	
• Severe	46 (16.7%)	
• Very Severe	35 (12.7%)	
Pads Worn per Day		
	1.40 ± 1.96	1.17, 1.64
Impact of UI on ADL (IIQ-7)		
	16.31 ± 22.48	13.64, 18.98
Duration of Urinary Incontinence (mos)		
	57.26 ± 82.39	47.48, 67.04
Symptom Change Since Onset		
• Better	60 (21.8%)	
• Unchanged	137 (49.8%)	
• Worse	78 (28.4%)	
UI a Medical Problem		
• Yes	225 (81.2%)	
• No	36 (13.1%)	
• Did Not Know	14 (5.1%)	

One hundred and thirty (47.3%) survey respondents reported having a close relative and 116 (42.2%) reported having a close friend with urinary incontinence. In total 178 (64.7%) survey respondents reported having a close friend or relative with urinary incontinence.

Survey respondents were more likely to discuss incontinence care seeking with a female friend (32%) or another female relative (32%), than their mother (19.3%) or husband/partner (16.4%). Thirty seven and one half percent of survey respondents reported discussing seeking incontinence care with their usual health care practitioner. Discussing incontinence care seeking with their usual health care practitioner was associated with actual incontinence care seeking in the expected direction. Sixty nine (67%) survey respondents who had discussed incontinence care seeking with their usual health care practitioner had actually sought care compared to 7 (4.1%) survey respondents who had not discussed incontinence care with their usual health care practitioner ($p < 0.001$, Odds ratio 47.8, 95% CI 20.23, 113.12). Still 34 (33%) of women who had discussed incontinence care seeking with their usual healthcare practitioner had not sought care at the time of the survey.

Only 76 of 275 (27.4%) incontinent survey respondents sought incontinence care from a healthcare practitioner over the last 12 months.

Establishing the Factor Validity of the Expectations of Incontinence Care Seeking Questionnaire (EICS-Q) and the Barriers to Incontinence Care Seeking Questionnaire (BICS-Q)

Utility (Expectations * Value) Measurement Model

Figure 6 illustrates the structure of my Expectation of Incontinence Care Seeking Questionnaire (EICS-Q).

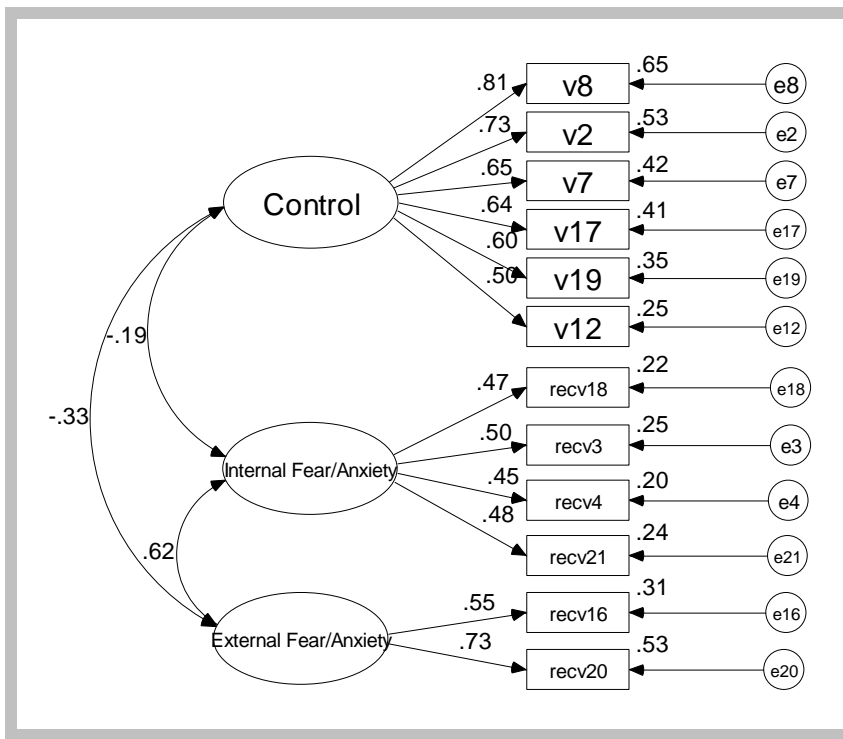

Figure 6. Measurement model for my Expectations of Incontinence Care Seeking Questionnaire (EICS-Q). n = 275.

Three factors explained 42.7% of the variance on the original 21-item questionnaire. In the final model, 6 good outcome items loaded on a control factor (factor loadings 0.502-0.806). The two expectation items with the highest loadings on the control factor were “I would be able to resume my normal activities,” (r = 0.806) and

“I would regain control of my life.” ($r = 0.726$). Four bad outcome items loaded on an internalized fear/anxiety factor (factor loadings 0.449-0.497). The two expectation items with the highest loadings on the internalized fear/anxiety factor were “I would be told it was caused by something I had done in my past,” ($r = 0.485$) and “I would be labeled a hypochondriac.” ($r = 0.497$). Two bad outcome items loaded on an externalized fear/anxiety factor (factor loadings 0.553-0.726). The two expectation items with the highest loadings on the externalized fear/anxiety factor were “I would be referred to a specialist,” ($r = 0.553$) and “my doctor would tell me I needed surgery ($r = 0.726$). A CMIN/DF of 1.70, GFI of 0.95, PGFI of 0.621, CFI of 0.95, a RMSEA of 0.050 (P CLOSE 0.463), and Hoelter 0.05 and 0.01 indices of 218 and 246, respectively, established the fit of my final expectation questionnaire. Cronbach’s alpha coefficient for the final 12 item expectation questionnaire was 0.56 (Control subscale 0.82, internalized fear/anxiety subscale 0.53, and externalized fear/anxiety subscale 0.57). The final expectation questionnaire and its scoring can be found in Appendix 2.

Barrier Measurement Model

Figure 7 illustrates the structure of my Barriers to Incontinence Care Seeking Questionnaire (BICS-Q)

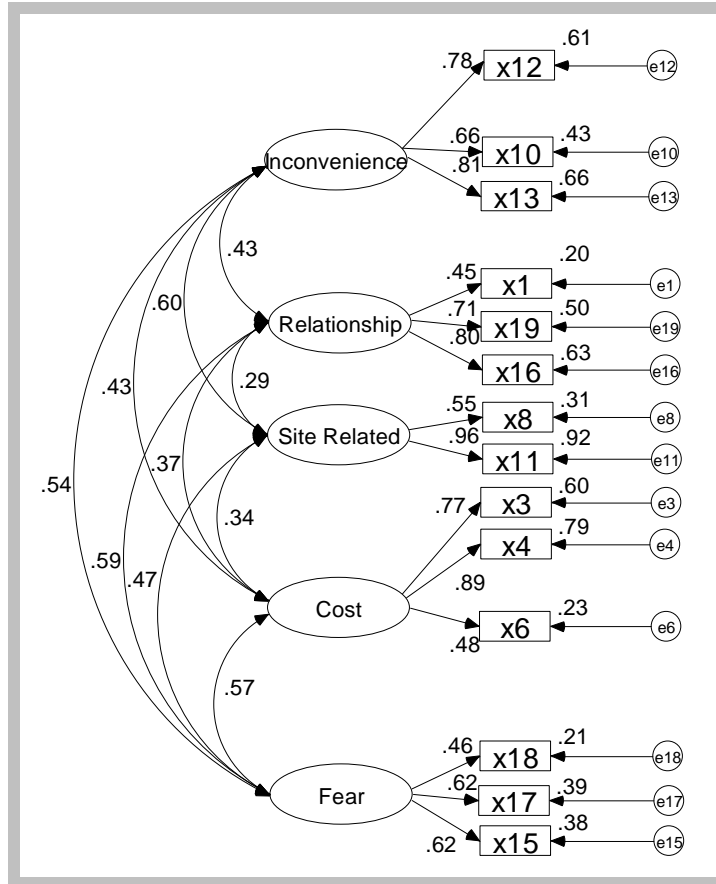

Figure 7. Measurement model for Barriers to Incontinence Care Seeking Questionnaire (BICS-Q). n = 275

Only 1 of 6 barrier items (“Office hours at the office or clinic are limited”) from the incontinence medical literature was retained in the model. This barrier item loaded on the inconvenience factor with a factor loading of 0.812. In the final model, the 14-item Barriers to Incontinence Care Seeking Questionnaire (BICS-Q) contained 3 items that loaded on the inconvenience factor (factor loadings 0.659-0.812). The barrier item

with the highest loading ($r = 0.812$) on the inconvenience factor was “office hours at the office or clinic are limited.” Three items loaded on the relationship factor (factor loadings 0.452-0.796). The barrier item with the highest loading ($r = 0.796$) on the relationship factor was “the physician or nurse practitioner doesn’t take time to explain what he or she is doing or why, or answer my questions.” Two items loaded on the site-related factor (factor loadings 0.554-0.960). The barrier item with the highest loading ($r = 0.960$) on the site-related factor was “the office or clinic is too far away.” Three items loaded on the cost factor (factor loadings 0.481-0.891). The barrier item with the highest loading ($r = 0.891$) on the cost factor was “my insurance is too complicated to figure out.” Three items loaded on the fear factor (factor loadings 0.457-0.624). The barrier item with the highest loading ($r = 0.624$) on the fear factor was “I am afraid to find out I have a serious problem.” A CMIN/DF of 2.12, GFI of 0.93, PGFI of 0.595 CFI of 0.93, RMSEA of 0.064 (P CLOSE 0.060), and Hoelter 0.05 and 0.01 indices of 169, and 188, although low, established the fit of my final Barriers to Incontinence Care Seeking Questionnaire (BICS-Q). Cronbach’s alpha coefficient for the final 14-item Barriers to Incontinence Care Seeking Questionnaire (BICS-Q) was 0.828 (Inconvenience subscale 0.79, Relationship subscale 0.68, Site related subscale 0.69, cost subscale 0.71, fear subscale 0.57). The final barrier questionnaire and its scoring can be found in Appendix 3.

Establishing Predictors Of Incontinence Care Seeking For An Ethnically Heterogeneous Incontinent Female Population As Guided By The Theory Of Care Seeking Behavior

Incontinence Care Seeking

Social norms and habits were the only psychosocial variables from the Theory of Care Seeking Behavior associated with incontinence care seeking during bivariate analysis. Incontinent women with group 3 social norm scores were more likely to seek incontinence care compared to women in the other two lower social norm score groups ($\chi^2=9.9, df=2, p=0.007$). Incontinent women with group 3 habit scores were more likely to seek care compared to women with group 2 habit scores who were more likely to seek care compared to women with group 1 habit scores ($\chi^2=15.4, df=2, p<0.0001$).

Table 5
Bivariate Analysis Of Incontinence Care Seeking On Psychosocial Variables

Psychosocial Variable	Sought Care		P
	Yes	No	
<u>Utility</u>			
• Group 1 (5.42- 34.58)	20 (22.0%)	71 (78.0%)	0.206
• Group 2 (34.67 – 56)	25 (27.2%)	67 (72.8%)	
• Group 3 (56.17-107.25)	31 (33.7%)	61 (66.3%)	
<u>Social Norms</u>			
• Group 1 (scores 1-2.25)	18 (20.2%)	71 (79.8%)	0.007
• Group 2 (scores 2.4-2.8)	15(20.8%)	57 (79.2%)	
• Group 3 (scores 3-4)	43 (37.7%)	71 (62.3%)	

<u>Affect</u>			
Positive affect			
• Group 1 (scores 10-30)	27 (29.0%)	66 (71.0%)	
• Group 2 (scores 31-37)	29 (30.2%)	67 (69.8%)	0.540
• Group 3 (scores 38-50)	20 (23.3%)	66 (76.7%)	
Negative affect			
• Group 1 (scores 10-16)	21 (23.1%)	70 (76.9%)	
• Group 2 (scores 17-23)	28 (29.5%)	67 (70.5%)	0.489
• Group 3 (scores 24-50)	27 (30.3%)	62 (69.7%)	
<u>Habit</u>			
• Group 1 (scores 3-6)	14 (17.7%)	65 (82.3%)	
• Group 2 (score 7)	18 (20.5%)	70 (79.5%)	<0.0001
• Group 3 (scores 8-9)	44 (40.7%)	64 (59.3%)	

Age ($\chi^2=8.21$, $df=2$, $p=0.016$), health insurance coverage ($\chi^2=17.29$, $df=2$, $p=0.001$), symptom change ($\chi^2=16.82$, $df=2$, $p=0.0002$), incontinence severity ($\chi^2=24.90$, $df=3$, $p<0.0001$), pads worn per day ($\chi^2=33.61$, $df=3$, $p<0.0001$), impact of urinary incontinence on activities of daily living ($\chi^2=18.80$, $df=2$, $p<0.0001$), , preventive health behavior scores ($\chi^2=8.88$, $df=2$, $p=0.12$), , and powerful other health locus of control scores ($\chi^2=7.66$, $df=2$, $p=0.022$) were the clinical and demographic variables that were associated with incontinence care seeking.

Table 6

Bivariate Analysis of Incontinence Care Seeking on Clinical and Demographic, andBarrier Variables

Clinical and Sociodemographic, and Barrier Variables	Sought Care		P
	Yes	No	
<u>Age</u>			
• 35-47 y.o	14 (16.3%)	72 (83.7%)	0.016
• 48-58 y.o	31 (31.6%)	67 (68.4%)	
• 59-85 y.o	31 (34.1%)	60 (65.9%)	
<u>Ethnicity</u>			
• <u>Hispanic</u>	17 (21.3%)	63 (78.8%)	0.100
• <u>Blacks</u>	24 (25.3%)	71 (74.7%)	
• <u>Whites</u>	35 (35.0%)	65 (6.05%)	
<u>Health Insurance</u>			
• Government	43 (42.2%)	59 (57.8%)	0.001
• Private	27 (19.9%)	109 (80.1%)	
• None	6 (16.2%)	31 (83.8%)	
<u>Socioeconomic Status</u>			
• Group1 (scores 4-27)	32 (36.4%)	56 (63.6%)	0.058
• Group 2 (scores 28-33)	25 (26.3%)	70 (73.7%)	
• Group 3 (scores 34-52)	19 (20.7%)	73 (79.3%)	
<u>Marital Status</u>			
• Married	37 (28.2%)	94 (71.8%)	0.830
• Unmarried	39 (27.1%)	105 (72.9%)	

<u>Symptom Duration</u>			
• ≤ 1 year	25 (25.5%)	73 (74.5%)	0.249
• 2-3 years	30 (34.1%)	58 (65.9%)	
• ≥ 4 years	21 (23.6%)	68 (76.4%)	
<u>Symptom Change</u>			
• Better	27 (45.0%)	33 (55.0%)	0.0002
• No change	24 (17.5%)	113 (82.5%)	
• Worse	25 (32.1%)	53 (67.9%)	
<u>Incontinence type</u>			
• Stress incontinence	17 (19.8%)	69 (80.2%)	0.109
• Mixed incontinence	51 (30.4%)	117 (69.6%)	
• Urge incontinence	8 (38.1%)	13 (61.9%)	
<u>Incontinence Severity</u>			
Original			
• Slight	13 (15.9%)	69 (84.1%)	<0.0001
• Moderate	24 (21.4%)	88 (78.6%)	
• Severe	22 (47.8%)	24 (52.2%)	
• Very severe	17 (48.6%)	69 (51.4%)	
Modified			
• Mild	15 (17.2%)	72 (82.8%)	<0.0001
• Moderate	13 (17.6%)	61 (82.4%)	
• Severe	48 (42.1%)	66 (57.9%)	
<u>Pads per day</u>			
• No pads	17 (14.8%)	98 (85.2%)	<0.0001
• 1-2 pads	31 (28.7%)	77 (71.3%)	
• 3 or more pads	28 (53.8%)	24 (46.2%)	

<u>Close friend or relative with UI</u>			
• Yes	54 (30.3%)	124 (69.7%)	0.175
• No	22 (22.7%)	75 (77.3%)	
<u>Impact of UI on ADL</u>			
• Group 1 (scores 0-4)	18 (16.5%)	91 (83.5%)	<0.0001
• Group 2 (scores 4.76-14.28)	20 (25.0%)	60 (75.0%)	
• Group 3 (scores 19.05-100)	38 (44.2%)	48 (5.8%)	
<u>Preventive health behaviors</u>			
• Group 1 (scores 4-12)	26 (26.8%)	71 (73.2%)	0.012
• Group 2 (scores 13-14)	19 (19.2%)	80 (80.8%)	
• Group 3 (scores 15-16)	31 (39.2%)	48 (60.8%)	
<u>Physical exam frequency</u>			
• More than 3 years since last visit or never	3 (13.0%)	20 (87%)	0.09
• Every 2-3 years	6 (17.1%)	29 (82.9%)	
• Annually	57 (28.6%)	142 (71.4%)	
Once per month	10 (55.6%)	8 (44.4%)	
<u>UI as “a medical problem</u>			
• Yes	62 (27.6%)	163 (72.4%)	0.949
• No	14 (28%)	36 (72.0%)	

<u>Health locus of control</u>			
Powerful others (PHLC)			
• Group 1 (scores 6-18)	20 (21.7%)	72 (78.3%)	0.022
• Group 2 (scores 19-24)	20 (22.7%)	68 (77.3%)	
• Group 3 (scores 25-36)	36 (37.9%)	59 (62.1%)	
Internal (IHLC)			
• Group 1 (scores 7-24)	27 (31.4%)	59 (68.6%)	0.161
• Group 2 (scores 25-28)	19 (20.4%)	74 (79.6%)	
• Group 3 (scores 29-36)	30 (31.3%)	66 (68.8%)	
Chance (CHLC)			
• Group 1 (scores 6-15)	27 (29.3%)	65 (70.7%)	0.426
• Group 2 (scores 16-22)	22 (22.9%)	74 (77.1%)	
• Group 3 (scores 23-35)	27 (31.0%)	60 (69.0%)	

<u>Barriers</u>			
• Group 1 (score 0)	26 (25.5%)	76 (74.5%)	0.784
• Group 2 (scores 1-5)	23 (27.7%)	60 (72.3%)	
• Group 3 (scores 6-36)	27 (30.0%)	63 (70.0%)	

Ethnicity

I found no differences in barriers to incontinence care seeking, affect, social norms, or habits amongst my three surveyed ethnic groups. I did find differences in utility of incontinence care seeking amongst my three surveyed ethnic groups. Both Blacks, and Hispanics reported greater utility in incontinence care seeking than Whites ($\chi^2=12.65$, $df=4$, $p=0.013$).

Table 7

Bivariate Analysis of Psychosocial Variables on Ethnicity

Psychosocial Variable	Ethnicity			P
	White	Black	Hispanic	
<u>Utility</u>				
• <u>Group 1 (scores 5.42- 34.58)</u>	46 (46.0%)	27 (28.4%)	18 (22.5%)	0.013
• <u>Group 2 (scores 34.67 – 56)</u>	27 (27.0%)	33 (34.7%)	32 (40.0%)	
• <u>Group 3 (scores 56.17-107.25)</u>	27 (27.0%)	35 (36.8%)	30 (37.5%)	
<u>Social Norms</u>				
• Group 1 (scores 1-2.25)	38 (38.0%)	24 (25.3%)	27 (33.8%)	0.433
• Group 2 (scores 2.4-2.8)	23 (23.0%)	28 (29.5%)	21 (26.3%)	
• Group 3 (scores 3-4)	39 (39.0%)	43 (45.3%)	32 (40.0%)	
<u>Affect</u>				
Positive affect				
• Group 1 (scores 10-30)	41 (41.0%)	26 (27.4%)	26 (32.5%)	0.075
• Group 2 (scores 31-37)	33 (33.0%)	30 (31.6%)	33 (41.3%)	
• Group 3 (scores 38-50)	26 (26.0%)	39 (41.1%)	21 (26.3%)	
Negative affect				
• Group 1 (scores 10-16)	31 (31.0%)	32 (33.7%)	28 (35.0%)	0.975
• Group 2 (scores 17-23)	35 (35.0%)	32 (33.7%)	28 (35.0%)	
• Group 3 (scores 24-50)	34 (34.0%)	31 (32.6%)	24 (30.0%)	

<u>Habit</u>				
• Group 1 (scores 3-6)	31 (31.0%)	23 (24.2%)	25 (31.3%)	
• Group 2 (score 7)	30 (30.0%)	34 (35.8%)	24 (30.0%)	0.790
• Group 3 (scores 8-9)	39 (39.0%)	38 (40.0%)	31 (38.8%)	

Survey respondent mean age from each of my three ethnic groups were similar at the time of the survey. Incontinence type differed amongst my three surveyed ethnic groups. Urge urinary incontinence was most prevalent in Blacks (10.5%) compared to Whites (6.0%) or Hispanics (6.3%), while stress urinary incontinence was most prevalent in Whites (41.0%) compared to Blacks (21.1%) or Hispanics (31.3%) ($\chi^2=9.72$, $df=4$, $p=0.045$).

Despite these differences in incontinence type, I found no difference amongst my three surveyed ethnic groups for incontinence severity, symptom duration, symptom change since onset, pads worn per day, or impact of urinary incontinence on activities of daily living. I also found no difference amongst my three surveyed ethnic groups for the identification of close friends or relatives with urinary incontinence, preventive health behaviors, physical exam frequency, and recognition of urinary incontinence as a medical problem.

I did find differences in marital status amongst my three surveyed ethnic groups. Both Whites (54%), and Hispanics (57.5%) were more likely to be married than Blacks (32.6%) ($\chi^2=13.32$, $df=2$, $p=0.001$).

Both Blacks and Hispanics believed that powerful others were responsible for their health, more than Whites ($\chi^2=10.56$, $df=4$, $p=0.032$) based on their higher PHLC

scores. Blacks, and Hispanics also believed that fate, luck, or chance was responsible for their health, more than Whites ($\chi^2=11.40$, $df=4$, $p=0.022$) based on their higher CHLC scores. Hispanics believed that they were personally responsible for their health more than Whites and Blacks based on their higher internal health locus of control scores ($\chi^2=15.42$, $df=4$, $p=0.004$).

Incontinence care seeking rates decreased from White (35%), to Blacks (25.3%), and Hispanics (21.3%) although these differences did not achieve statistical significance ($p = 0.1$) during bivariate analysis.

Table 8

Bivariate Analysis of Clinical and Demographic, and Barrier Variables on Ethnicity

Clinical and Sociodemographic, and Barrier Variables	Ethnicity			P
	White	Black	Hispanic	
<u>Age</u>				
• 35-47 y.o	32 (32.0%)	25 (26.3%)	29 (36.3%)	0.690
• 48-58 y.o	36 (36.0%)	37 (38.9%)	25 (31.3%)	
• 59-85 y.o	32 (32.0%)	33 (34.7%)	26 (32.5%)	
<u>Socioeconomic Status</u>				
• Group 1 (scores 4-27)	35 (35.0%)	29 (30.5%)	24 (30.0%)	0.459
• Group 2 (scores 28-33)	31 (31.0%)	39 (41.1%)	25 (31.3%)	
• Group 3 (scores 34-52)	34 (34.0%)	27 (28.4%)	31 (38.8%)	

<u>Marital Status</u>				
• Married	54 (54.0%)	31 (32.6%)	46 (57.5%)	0.001
• Unmarried	46 (46.0%)	64 (67.4%)	34 (42.5%)	
<u>Symptom Duration</u>				
• ≤ 1 year	27 (27.0%)	39 (41.1%)	32 (40.0%)	0.217
• 2-3 years	34 (34.0%)	30 (31.6%)	24 (30.0%)	
• ≥ 4 years	39 (39.0%)	26 (27.4%)	24 (30.0%)	
<u>Symptom Change</u>				
• Better	16 (16.0%)	23 (24.2%)	21 (26.3%)	0.310
• No change	57 (57.0%)	46 (48.4%)	34 (42.5%)	
• Worse	27 (27.0%)	26 (27.4%)	25 (31.3%)	
<u>Incontinence type</u>				
• Stress incontinence	41 (41.0%)	20 (21.1%)	25 (31.3%)	0.045
• Mixed incontinence	53 (53.0%)	65 (68.4%)	50 (62.5%)	
• Urge incontinence	6 (6.0%)	10 (10.5%)	5 (6.3%)	
<u>Incontinence Severity</u>				
Original				
• Slight	42 (42.0%)	36 (37.9%)	34 (42.5%)	0.082
• Moderate	24 (24.0%)	16 (16.8%)	6 (7.5%)	
• Severe	23 (23.0%)	29 (30.5%)	30 (37.5%)	
• Very severe	11 (11.0%)	14 (14.7%)	10 (12.5%)	
Modified				
• Mild	24 (24.0%)	31 (32.6%)	32 (40.0%)	0.101
• Moderate	30 (30.0%)	21 (22.1%)	23 (28.8%)	
• Severe	46 (46.0%)	43 (45.3%)	25 (31.3%)	

<u>Pads per day</u>				
• No pads	39 (39.0%)	42 (44.2%)	34 (42.5%)	0.896
• 1-2 pads	43 (43.0%)	34 (35.8%)	31 (38.8%)	
• 3 or more pads	18 (18.0%)	19 (20.0%)	15 (18.8%)	
<u>Close friend or relative with UI</u>				
• Yes	70 (70.0%)	57 (60.0%)	51 (63.8%)	0.336
• No	30 (30.0%)	38 (40.0%)	29 (36.3%)	
<u>Impact of UI on ADL</u>				
• Group 1 (scores 0-4)	38 (38.0%)	43 (45.3%)	28 (35.0%)	0.439
• Group 2 (scores 4.76-14.28)	26 (26.0%)	28 (29.5%)	26 (32.5%)	
• Group 3 (scores 19.05-100)	36 (36.0%)	24 (25.3%)	26 (32.5%)	
<u>Preventive health behaviors</u>				
• Group 1 (scores 4-12)	42 (42.0%)	27 (28.4%)	28 (35.0%)	0.173
• Group 2 (scores 13-14)	37 (37.0%)	34 (35.8%)	28 (35.0%)	
• Group 3 (scores 15-16)	21 (21.0%)	34 (35.8%)	24 (30.0%)	
<u>Physical exam frequency</u>				
• More than 3 years since last visit or never	15 (15.0%)	3 (3.2%)	5 (6.3%)	0.095
• Every 2-3 years	12 (12.0%)	12 (12.6%)	11 (13.8%)	
• Annually	65 (65.0%)	75 (78.9%)	59 (73.8%)	
• Once per month	8 (8.0%)	5 (5.3%)	5 (6.3%)	
<u>UI as “a medical problem</u>				
• Yes	77 (77.0%)	78 (82.1%)	70 (87.5%)	0.192
• No	23 (23.0%)	17 (17.9%)	10 (12.5%)	

<u>Health locus of control</u>				
Power others (PHLC)				
• Group 1 (scores 6-18)	44 (44.0%)	25 (26.3%)	23 (28.8%)	
• Group 2 (scores 19-24)	32 (32.0%)	32 (33.7%)	24 (30.0%)	0.032
• Group 3 (scores 25-36)	24 (24.0%)	38 (40.0%)	33 (41.3%)	
Internal (IHLC)				
• Group 1 (scores 7-24)	39 (39.0%)	32 (33.7%)	15 (18.8%)	
• Group 2 (scores 25-28)	34 (34.0%)	35 (36.8%)	24 (30.0%)	0.004
• Group 3 (scores 29-36)	27 (27.0%)	28 (29.5%)	41 (51.3%)	
Chance (CHLC)				
• Group 1 (scores 6-15)	44 (44.0%)	26 (27.4%)	22 (27.5%)	
• Group 2 (scores 16-22)	34 (34.0%)	37 (38.9%)	25 (31.3%)	0.022
• Group 3 (scores 23-35)	22 (22.0%)	32 (33.7%)	33 (41.3%)	

<u>Barriers</u>				
• Group 1 (score 0)	30 (30.0%)	40 (42.1%)	32 (40.0%)	
• Group 2 (scores 1-5)	34 (34.0%)	26 (27.4%)	23 (28.8%)	0.479
• Group 3 (scores 6-36)	36 (36.0%)	29 (30.5%)	25 (31.3%)	

Hypothesis Testing Using Logistic Regression Analysis

Hypothesis 1 - Psychosocial variables directly predict incontinence care seeking as guided by the Theory of Care Seeking Behavior.

Group 3 survey respondents with high social norms scores (scores 3-4) were 2.7 times more likely to seek incontinence care compared to group 1 survey respondents with low social norms scores (scores 1-2.25) (OR 2.171, 95% CI 1.089, 4.328). Group 3 survey respondents with high habit scores (scores 8-9) were 3 times more likely to seek

incontinence care compared to women with low habit scores (scores 3-6) (OR 3.189, 95%CI 1.55, 6.579). My model that included social norms and habits explained 13.7% of the variance in incontinence care seeking behavior.

Table 9

Logistic Regression Of Incontinence Care Seeking On Psychosocial Variables

	B	S.E.	Wald	df	Sig.	OR	95.0% C.I.for OR	
							Lower	Upper
HABIT			13.470	2	.001			
HABIT (Group 2)	.170	.405	.176	1	.675	1.185	.536	2.620
HABIT (Group3)	1.160	.370	9.848	1	.002	3.189	1.546	6.579
NEG AFFECT			.675	2	.713			
NEG AFFECT (Group 2)	.287	.356	.650	1	.420	1.332	.663	2.675
NEG AFFECT (Group3)	.208	.364	.327	1	.567	1.232	.603	2.515
POS AFFECT			2.037	2	.361			
POS AFFECT (Group 2)	.058	.344	.029	1	.865	1.060	.540	2.080
POS AFFECT (Group 3)	-.424	.366	1.338	1	.247	.655	.319	1.342
SOCIAL NORMS			7.484	2	.024			
SOCIAL NORMS (Group 2)	-.039	.415	.009	1	.926	.962	.427	2.168
SOCIAL NORMS (Group 3)	.775	.352	4.849	1	.028	2.171	1.089	4.328
UTILITY			.397	2	.820			
UTILITY (Group 2)	.021	.373	.003	1	.955	1.021	.492	2.123
UTILITY (Group 3)	.200	.363	.303	1	.582	1.221	.599	2.489
Constant	-2.024	.483	17.563	1	.000	.132		

χ^2 (model) = 27.323, df = 10, p = 0.002, R² = 0.137

In summary, social norms and habit independently predicted incontinence care seeking consistent with the Theory of Care Seeking Behavior.

Hypothesis 2 - The predictive value of psychosocial variables for incontinence care seeking are modified (interaction effect) by barrier variables as guided by the Theory of Care Seeking Behavior.

I was unable to identify any interaction effect of barriers with psychosocial variables on incontinence care seeking contrary to the Theory of Care Seeking Behavior.

Hypothesis 3 - Clinical and Demographic variables, including ethnicity, do predict incontinence care seeking after adjusting for psychosocial, and barrier variables contrary to Theory of Care Seeking Behavior

Hispanic (OR 0.234, 95% CI 0.075, 0.728) survey respondents were 77% less likely to seek incontinence care than Whites. Survey respondents whose symptoms remained unchanged since their onset were 67% less likely to seek care compared to survey respondents whose symptoms improved since their onset (OR 0.327, 95% CI 0.114, 0.936). Survey respondents with urge urinary incontinence were 5 times more likely to seek incontinence care compared to survey respondents with stress urinary incontinence (OR 5.335, 95% CI 1.189, 23.934). Survey respondents who reported wearing 3 or more pads per day were almost 4 times more likely to seek incontinence care compared to survey respondents who reported no need to wear pads (OR 3.633, 95% CI 1.066, 12.374). Group 3 survey respondents with high impact of urinary incontinence on their activities of daily living (scores 19-100) were 5 times more likely to seek incontinence care compared to group 1 survey respondents with low impact of urinary incontinence on activities of daily living (OR 5.270, 95% CI 1.590, 17.466). Group 2 survey respondents with middle preventive health scores (scores 13-14) were 69% less

likely to seek incontinence care compared to group 1 survey respondents with low preventive health scores (scores 4-12) (OR 0.305, 95% CI 0.112, 0.830). Unmarried survey respondents were 69% less likely to seek incontinence care compared to married survey respondents (OR 0.308, 95% CI 0.127, 0.747). After entering these clinical and sociodemographic variables to my model, social norms and habits were no longer predictive of incontinence care seeking. My model explained 51% of the variance in incontinence care seeking behavior.

Table 10
Logistic Regression of Incontinence Care Seeking on Clinical and Sociodemographic Variables Adjusting for Psychosocial Variables

	B	S.E.	Wald	df	Sig.	OR	95.0% C.I. for OR	
							Lower	Upper
HABIT			4.863	2	.088			
HABIT (Group 2)	-1.265	.821	2.376	1	.123	.282	.057	1.410
HABIT (Group 3)	-.587	1.220	.231	1	.631	.556	.051	6.082
NAFFECT			1.558	2	.459			
NAFFECT (Group 2)	-.691	.715	.934	1	.334	.501	.123	2.035
NAFFECT (Group 3)	-1.546	1.243	1.547	1	.214	.213	.019	2.437
PAFFECT			.950	2	.622			
PAFFECT (Group 2)	.248	.756	.108	1	.743	1.281	.291	5.637
PAFFECT (Group 3)	-.346	1.143	.092	1	.762	.707	.075	6.641
SOCIAL NORMS			3.762	2	.152			
SOCIAL NORMS (Group 2)	.506	.793	.408	1	.523	1.659	.351	7.845
SOCIAL NORMS (Group 3)	1.895	1.226	2.391	1	.122	6.652	.602	73.473
UTILITY			1.174	2	.556			
UTILITY (Group 2)	.800	.776	1.061	1	.303	2.224	.486	10.187
UTILITY (Group 3)	1.246	1.207	1.065	1	.302	3.476	.326	37.020

PAFFECT*BARRIER	.159	.280	.323	1	.570	1.172	.678	2.028
NAFFECT*BARRIER	.194	.279	.482	1	.488	1.214	.702	2.097
SOCIAL NORMS*BARRIER	-.434	.289	2.251	1	.134	.648	.368	1.142
UTILITY*BARRIER	-.214	.289	.549	1	.459	.807	.458	1.422
HABITS*BARRIER	.474	.283	2.803	1	.094	1.606	.922	2.797
AGE			2.621	2	.270			
AGE (Group 2)	.585	.529	1.220	1	.269	1.795	.636	5.065
AGE (Group 3)	1.019	.641	2.528	1	.112	2.772	.789	9.740
SES			.432	2	.806			
SES (Group 2)	-.308	.492	.391	1	.532	.735	.280	1.929
SES (Group 3)	-.223	.503	.197	1	.657	.800	.298	2.144
ETHNICITY			6.514	2	.039			
BLACK	-.962	.538	3.198	1	.074	.382	.133	1.097
HISPANIC	-1.451	.578	6.289	1	.012	.234	.075	.728
SYMPTOM CHANGE			5.107	2	.078			
NO CHANGE	-1.118	.537	4.342	1	.037	.327	.114	.936
WORSE	-1.178	.601	3.845	1	.050	.308	.095	.999
INCTYPE			4.784	2	.091			
MIXED UI	.658	.526	1.563	1	.211	1.931	.688	5.414
URGE UI	1.674	.766	4.779	1	.029	5.335	1.189	23.934
PADS PER DAY			4.263	2	.119			
1-2 PADS PER DAY	.510	.464	1.211	1	.271	1.665	.671	4.131
3 OR MORE PADS PER DAY	1.290	.625	4.256	1	.039	3.633	1.066	12.374

INCONTINENCE SEVERITY				4.478	3	.214					
MODERATE	.171	.694	.061	1	.806	1.186	.304	4.626			
SEVERE	-1.052	.726	2.100	1	.147	.349	.084	1.449			
VERY SEVERE	-.651	.895	.529	1	.467	.522	.090	3.013			
UI IMPACT ON ADL'S				7.408	2	.025					
UI IMPACT (Group 2)	.832	.542	2.362	1	.124	2.299	.795	6.647			
UI IMPACT (Group 3)	1.662	.611	7.391	1	.007	5.270	1.590	17.466			
PREV HLTH BEHAV				9.697	2	.008					
PREV HLTH BEHAV (Group 2)	-1.186	.510	5.402	1	.020	.305	.112	.830			
PREV HLTH BEHAV (Group 3)	.339	.498	.462	1	.497	1.403	.528	3.727			
PHYSICAL EXAM FREQ				2.436	3	.487					
EVERY 2-3 YEARS	.923	.964	.916	1	.339	2.516	.380	16.654			
ANNUALLY	1.239	.874	2.012	1	.156	3.453	.623	19.131			
ONCE A MONTH	1.607	1.101	2.130	1	.144	4.989	.576	43.195			
UNMARRIED				-1.178	.452	6.784	1	.009	.308	.127	.747
IHLC				1.261	2	.532					
IHLC (Group 2)	-.547	.508	1.159	1	.282	.579	.214	1.566			
IHLC (Group 3)	-.117	.508	.053	1	.819	.890	.329	2.411			
CHLC				1.257	2	.533					
CHLC (Group 2)	-.427	.494	.746	1	.388	.653	.248	1.719			
CHLC (Group 3)	.092	.566	.026	1	.871	1.096	.362	3.323			
PHLC				1.103	2	.576					
PHLC (Group 2)	-.518	.549	.891	1	.345	.596	.203	1.746			
PHLC (Group 3)	-.045	.562	.006	1	.936	.956	.318	2.875			
HEALTH INSURANCE				.627	2	.731					
PRIVATE	-.276	.541	.260	1	.610	.759	.263	2.190			
NONE	-.578	.755	.587	1	.444	.561	.128	2.461			
CONSTANT				-1.777	1.788	.988	1	.320	.169		

χ^2 (model) = 119.85, df=46, p<0.0001, R² = 0.510

In summary, ethnicity, symptom change since onset, incontinence type, pads worn per day, impact of urinary incontinence on activities of daily living, preventive health scores, and marital status were independent predictors of incontinence care seeking, after adjusting for psychosocial and barrier variables, contrary to the Theory of Care Seeking Behavior.

Hypothesis 4 - Clinical and demographic variables, excluding ethnicity, and psychosocial variables explain any significant association between ethnicity and incontinence care seeking.

Group 3 survey respondents with high habit scores (scores 8-9) were 3.5 times more likely to seek incontinence care compared to group 1 survey respondents with low habit scores (scores 3-6) (OR 3.533, 95% CI 1.464, 8.522). Black (OR 0.399, 95% CI 0.165, 0.963) and Hispanic (OR 0.249, 95% CI 0.101, 0.611) survey respondents were 60 and 75% less likely to seek incontinence care than Whites. Survey respondents whose symptoms were unchanged since onset (OR 0.221, 95% CI 0.091, 0.536) or worse since onset (OR 0.252, 95% CI 0.098, 0.647) were 78 and 75% less likely to seek incontinence care compared to survey respondents whose symptoms were better since onset. Survey respondents with urge urinary incontinence were almost 6.5 times more likely to seek incontinence care compared to survey respondents with stress urinary incontinence (OR 6.390, 95% CI 1.658, 24.632). Survey respondents who wore 3 or more pads per day were 7 times more likely to seek incontinence care compared to survey respondents who wore none (OR 7.006, 95% CI 2.583, 19.00). Group 3 survey respondents whose urinary incontinence had a high impact on their activities of daily living (scores 19-100) were 3.8

times more likely to seek incontinence care compared to group 1 survey respondents whose urinary incontinence had a low impact on their activities of daily living (scores 0) (OR 3.768, 95% CI 1.427, 9.945). My model explained 40.8% of the variance in incontinence care seeking behavior.

Table 11

Logistic Regression of Incontinence Care Seeking on Psychosocial, and Clinical and Demographic Variables Entered Simultaneously

	B	S.E.	Wald	df	Sig.	OR	95.0% C.I. for OR	
							Lower	Upper
HABIT			10.539	2	.005			
HABIT (Group 2)	.182	.462	.155	1	.694	1.200	.485	2.969
HABIT (Group 3)	1.262	.449	7.890	1	.005	3.533	1.464	8.522
SOCIAL NORMS			3.494	2	.174			
SOCIAL NORMS (Group 2)	-.452	.484	.871	1	.351	.637	.247	1.644
SOCIAL NORMS (Group 3)	.340	.426	.637	1	.425	1.405	.610	3.238
UTILITY			.706	2	.703			
UTILITY (Group 2)	.365	.462	.623	1	.430	1.440	.582	3.560
UTILITY (Group 3)	.097	.438	.049	1	.825	1.102	.467	2.598
NAFFECT			1.855	2	.396			
NAFFECT (Group 2)	-.395	.447	.782	1	.377	.674	.281	1.617
NAFFECT (Group 3)	-.653	.480	1.851	1	.174	.520	.203	1.333
PAFFECT			1.007	2	.604			
PAFFECT (Group 2)	.309	.417	.549	1	.459	1.362	.602	3.083
PAFFECT (Group 3)	-.086	.443	.038	1	.845	.917	.385	2.186
ETHNICITY			9.557	2	.008			
BLACK	-.920	.450	4.177	1	.041	.399	.165	.963
HISPANIC	-1.392	.459	9.193	1	.002	.249	.101	.611

SYMPTOM CHANGE			12.378	2	.002			
NO CHANGE	-1.511	.453	11.138	1	.001	.221	.091	.536
WORSE	-1.379	.482	8.195	1	.004	.252	.098	.647
INCONTINENCE TYPE			7.527	2	.023			
MIXED UI	.389	.433	.805	1	.369	1.475	.631	3.447
URGE UI	1.855	.688	7.258	1	.007	6.390	1.658	24.632
PADS PER DAY			14.639	2	.001			
1-2 PADS PER DAY	.801	.408	3.852	1	.050	2.228	1.001	4.960
3 OR MORE PADS PER DAY	1.947	.509	14.624	1	.000	7.006	2.583	19.000
UI IMPACT ON ADL'S			7.255	2	.027			
UI IMPACT (Group 2)	.602	.457	1.739	1	.187	1.827	.746	4.472
UI IMPACT (Group 3)	1.327	.495	7.175	1	.007	3.768	1.427	9.945
PREV HLTH BEHAV			8.518	2	.014			
PREV HLTH BEHAV (Group 2)	-.647	.429	2.278	1	.131	.523	.226	1.213
PREV HLTH BEHAV (Group 3)	.603	.424	2.022	1	.155	1.827	.796	4.191
UNMARRIED	-.668	.363	3.380	1	.066	.513	.251	1.045
CONSTANT		-1.243	.774	2.577	1	.108	.289	

χ^2 (model) = 91.293, df = 23, p < 0.0001, R² = 0.408

In summary, habit, ethnicity, symptom change since onset, incontinence type, pads per day, and impact of urinary incontinence on activities of daily living independently predicted incontinence care seeking behavior. None of the measured clinical and demographic, or psychosocial and barrier variables explained the association of ethnicity with incontinence care seeking contrary to the Theory of Care Seeking Behavior.

Hypothesis 5 - The predictive value of clinical and demographic variables, including ethnicity, and psychosocial variables for incontinence care seeking is modified (interaction effect) by barrier variables.

I was unable to identify any interaction effect of barriers with clinical and sociodemographic variables, including ethnicity, and psychosocial variables on incontinence care seeking contrary to the Theory of Care Seeking Behavior.

CHAPTER V

DISCUSSION / FUTURE AREAS OF RESEARCH

To my knowledge, this is the first comparative study to identify ethnicity as an independent predictor of incontinence care seeking. Sampselles found that only 12% of incontinent women had discussed their problem with a provider. Rates of incontinence care seeking differed by ethnicity. Chinese women (5.6%) and Hispanic women (7.8%) were less likely to discuss incontinence with a healthcare provider than White (13.7%), African-American (12.5%), and Japanese women (10.2%). However ethnicity was overwhelmed by increasing incontinence severity, increasing duration of urinary incontinence, and seeing a doctor within the past year in the multivariable analysis. After controlling for these variables in the model, ethnicity no longer predicted the likelihood of discussing leakage with a healthcare provider [Sampselles 2002]. In my study, clinical and demographic variables including socioeconomic status and measures of symptom severity did not explain the association of ethnicity on incontinence care seeking. Our results likely differed from Sampselles's results because of differences in sampled populations, expressed purpose of our surveys which may have influenced responses, and the definitions used to define incontinence care seeking. Contrary to the Theory of Care Seeking Behavior, psychosocial and barrier variables also did not explain the association of ethnicity on incontinence care seeking found in our study.

Hypothesis 1 Psychosocial variables directly predict incontinence care seeking as guided by the Theory of Care Seeking Behavior

Consistent with theory, both habit and social norms were predictive of care seeking prior to including clinical and demographic variables into my model. Habits are positive or negative routines, or automatic responses that are traditionally a learned behavior. Specifically, care seeking habits are those learned routines or automatic responses to health symptoms. In my study, I determined the health care seeking habits of survey respondents to symptoms of urinary tract infections, depression, and general health symptoms. Survey respondents with high habit scores were three times more likely to seek care than survey respondents with low habit scores. The strength of care seeking habits for predicting incontinence care seeking is suggested by the ability of this predictor to overcome the poor reliability of its measure (Cronbach's $\alpha = 0.44$).

It is unclear from my study where these learned behaviors were developed. A "seek care right away" habit could have been learned through conversations with significant others, or from past positive personal experiences with the health care system. Conversely, a "do not seek care" habit could have been learned through conversations with significant others, or from past negative personal experiences with the health care system.

As a learned behavior positive and negative habits are likely to be intimately linked to the accepted social norms of an individual's social group or culture. Traditionally, urinary incontinence was a social "taboo" forcing affected individuals from any discussions about the disorder. The increasing publicity of urinary incontinence as a

medical disorder may have made it acceptable for affected individuals to discuss their symptoms with significant others, establishing a new social norm. This suggests that a habit of seeking incontinence care “right away” will surpass a “wait and see approach” habit, or a “do not seek care” habit, as soon as incontinence care seeking becomes the social norm for affected individuals.

Like many learned behaviors, habits are difficult to change. Smoking, overeating, gambling, narcotic and alcohol treatment programs including alcohol anonymous embrace peer support and spirituality to change habitual and dysfunctional behaviors in response to stimuli such as fear and anxiety. Interventions designed to increase the percentage of women who seek incontinence care should leverage these approaches when dealing with incontinent women because fear and anxiety of social isolation may prevent affected individuals from formal diagnosis and treatment.

Consistent with the Theory of Care Seeking Behavior, I found social norms to be an independent predictor of incontinence care seeking. Survey respondents whose actual or perceived social norms supported incontinence care seeking, when faced with symptoms, were more likely to seek incontinence care compared to survey respondents whose actual or perceived social norms were less supportive. These findings are consistent with clinical experience where patients commonly report discussions they have had with significant others who make recommendations based on past personal experiences, positive or negative. Frequently, physicians are confronted with the incontinent patient who states that her friend’s “bladder tack/repair did not work” or her primary care physician said that “results are only temporary”, despite medical evidence to the contrary. Alternatively patients will ask for the same intervention as their friend or

relative independent of its indications or their incontinence type. While these interactions may reflect a poor understanding of the condition and its treatments by the patient, it underscores the frequency with which affected individuals rely on significant others for medical advice.

Peer support programs and community education may be effective in managing social norms by effecting change in the community's opinions regarding incontinence care. Physicians can have a major impact on social norms by maximizing the number of positive physician/patient interactions during an initial office visit. This may require better education for primary care physicians about recent technologic advances in the non surgical and surgical management of urinary incontinence that improve treatment outcomes. Establishing clinical practice guidelines for the management of urinary incontinence may improve social norms by reducing the variability of care and eliminating the performance of outdated surgical procedures with poor treatment outcomes. Even patients who were failed by treatment can be advocates for seeking incontinence care if properly educated about the reasons behind suboptimal outcomes.

Hypothesis 2 The predictive value of psychosocial variables for incontinence care seeking is modified (interaction effect) by barrier variables as guided by the Theory of Care Seeking Behavior, and

Hypothesis 5 The predictive value of clinical and demographic variables, including ethnicity, and psychosocial variables for incontinence care seeking is modified (interaction effect) by barrier variables

Contrary to the Theory of Care Seeking Behavior, barriers did not modify (interaction effect) the association of psychosocial variables on incontinence care seeking. Barriers also did not modify the association of clinical and demographic variables (race, symptom change since onset, incontinence type, pads worn per day, or impact of urinary incontinence on activities of daily living) on incontinence care seeking.

One of the greatest barriers I encountered was the recruitment of Hispanic women using random digit dialing. After dialing 2286 numbers a total of 6939 times I was only able to recruit one Hispanic survey respondent. For this reason I purchased a national sample of listed telephone numbers for households with Hispanic surnames. In trying to establish connections with Hispanic community leaders and in dialing 1000 households with Hispanic surnames, I learned that an English language telephone call to Hispanic household got no cooperation. Men frequently answered the telephone in these homes and would not let a women in the home speak with the telephone interviewer. Many homes with Hispanic surnames did not have a female living in the home.

When a Hispanic woman was available for the interview, many seemed to be new arrivals to this country and were having trouble assimilating to the culture and language. All my telephone interviewers agreed that Hispanic women would have responded more positively to the interview if it was in Spanish. Ultimately, it took 3000 telephone calls to obtain all 75 Hispanic interviews. It is likely that many of these non-recruited least acculturated Hispanic survey candidates would have occupied my true low socioeconomic groups if cultural and language barriers could have been overcome.

My inability to recruit true low socioeconomic group members is reflected in the frequency distribution of my Barriers to Incontinence Care Seeking Questionnaire (BICS-

Q) scores which were non-Gaussian with extremely positive skew. Thirty seven percent of survey respondents reported no barriers to incontinence care seeking. The percentage of White (30%), Black (42.1%), and Hispanic (40.0%) survey respondents who reported no barriers were similar suggesting that homogeneity existed within and between my ethnic groups with respect to socioeconomic status and therefore barriers to incontinence care seeking. This homogeneity made it difficult to identify barriers as a modifier of psychosocial variables consistent with the Theory of Care Seeking Behavior or clinical and demographic variables as well.

I may be able to increase the variability of my barrier parameter estimates by recruiting the least acculturated Hispanics through the use of Spanish translated survey questions. This approach could minimize the homogeneity of my within and between ethnic group survey respondents, which would increase the probability of finding an interaction effect for barriers as suggested by the Theory of Care Seeking Behavior.

Hypothesis 3 Clinical and demographic variables, including ethnicity, predict incontinence care seeking after adjusting for psychosocial, and barrier variables contrary to the Theory of Care Seeking Behavior

Contrary to the Theory of Care Seeking Behavior clinical and demographic variables were predictive of incontinence care seeking after adjusting for psychosocial and barrier variables. Sandvik's incontinence severity index [Sandvik 2000] has been a consistent predictor of incontinence care seeking when predominantly White woman were surveyed in the United States or abroad. In my study, Sandvik's incontinence severity index, was only associated with incontinence care seeking during bivariate

analysis. Sandvik's incontinence severity index was not retained in my model to test hypothesis 3 suggesting that other variables are more salient predictors of incontinence care seeking in an ethnically heterogeneous female population.

Ethnicity, symptom change, incontinence type, pads worn per day, impact of urinary incontinence on activities of daily living, preventive health behaviors, and marital status, were all independent predictors of incontinence care seeking. At this point I will limit my discussion to the clinical and demographic variables (preventive health behaviors, and marital status) that were only retained in the model to test hypothesis 3. I will also discuss ethnic differences in psychosocial, and other clinical and demographic variables here because these potential confounders of the association of ethnicity with incontinence care seeking were entered into my model while testing hypothesis 3. Clinical and demographic variables (ethnicity, symptom change, incontinence type, pads worn per day, and impact of urinary incontinence on activities of daily living) that were retained in the model to test hypothesis 4, will be discussed in the following section.

Preventive health behaviors, as defined in my study, represents a specific type of health habit that similarly predicted incontinence care seeking for affected individuals. Yet, unlike habits, survey respondents with middle preventive health behavior scores were less likely to seek incontinence care compared to survey respondents with lower preventive health behaviors. It is likely that survey respondents who embrace preventive health behaviors choose self care and self treatment strategies to manage incontinence over professional treatment compared to women who do not embrace preventive health behaviors. Alternatively, survey respondents with the highest regard for preventive

medicine may not seek care for urinary incontinence because of a sense of failure or a surrendering to symptoms resulting from an inability to “control their bladder.”

My preventive health behavior measurement scale seemed particularly sensitive to systematic error because the negatively skewed frequency distribution of the preventive health behavior scores may not have lent themselves to ordinal categorization. In this situation, 3 level ordinal categorization of preventive health behavior scores may have inaccurately reflected the perceptions of survey respondents. Three level ordinal categorization was performed to maximize the variability of the preventive health behavior scores for correlation with incontinence care seeking. However, a closer inspection of group scores suggested otherwise. Group 1 consisted of 97 survey respondents with preventive health scores of 4-12, group 2 consisted of 99 survey respondents with preventive health scores of 13-14, and group 3 consisted of 79 survey respondents with preventive health scores of 15-16. Clearly perceptions of the importance of engaging in preventive health behaviors for survey respondents in groups 2 and 3 were similar, and differed from group 1 survey respondents reflecting a bimodal rather than a linear ordinal categorization of scores. This systematic error may explain the non-linear association of preventive health behavior scores and incontinence care seeking reported in Table 8. Preventive health behaviors were no longer associated with incontinence care seeking when entered simultaneously with psychosocial and clinical and sociodemographic variables in my model to test hypothesis 4.

Traditionally, women are the healthcare decision makers for the family. Norcross found that men were 2.7 times more likely than women to be influenced by a member of the opposite sex to visit a physician (95% CI 1.6, 4.6) and married patients were 2.4 times

more likely than unmarried patients to be influenced by a member of the opposite sex to visit a physician (95% CI 1.4, 4.3) after adjusting for sociodemographic characteristics. Patients who were encouraged to visit the physician by someone of the opposite sex were more likely to be Latino, Asian, or Native American and less likely to be Black or White. Based on the results of their study, the investigators declared that women were the principal healthcare brokers of the American family and might be viewed as the principal determiners of the health status of all members of society [Norcross 1996]. In my study, unmarried survey respondents were 69% less likely to seek incontinence care compared to married survey respondents. Clearly, husbands provided the necessary social support that allowed married incontinent female survey respondents to seek care. Alternatively, the negative impact of urinary incontinence on intimacy for married couples may have prompted survey respondents to seek care, yet this hypothesis remains untested. Clinicians recognize that conversations amongst affected women in a specific social network are instrumental in disseminating information, right or wrong, about urinary incontinence and the need to seek care for symptoms. Interventions that leverage the impact that women helping women and husbands helping wives have on health behaviors are likely to produce positive outcomes for urinary incontinence management.

I identified ethnic differences in the utility of incontinence care seeking, marital status, physician visit frequency, and health locus of control that were entered into my model to test hypothesis 3. Both Blacks and Hispanics reported a greater utility of incontinence care seeking compared to Whites, despite their lower rates of care seeking.

It is unclear why, Blacks and Hispanics had greater utility for incontinence care seeking than Whites despite similarities in measures of symptom severity. Differences in

incontinence type between my ethnic groups could have provided an alternative explanation for this finding. Blacks were more likely to report urge incontinence than Whites. The presence of urge urinary incontinence may confound the association of ethnicity on utility of incontinence care seeking because of the increased psychological effect, and impact of urge urinary incontinence on activities of daily living compared to other incontinence types.

However, I believe that differences in health locus of control between my ethnic groups were more likely to have explained differences in utility of incontinence care seeking than incontinence type. Black and Hispanic survey respondents who scored higher on the powerful others health locus of control scales also reported greater utility of incontinence care seeking. This finding is consistent with the concept of powerful others, such as doctors, being responsible for an individual's health status. Hispanics scored higher on the internal health locus of control scales compared to Blacks and Whites suggesting that they had a stronger belief that they were personally responsible for their health. Hispanics and Black survey respondents scored higher on the chance health locus of control scales compared to Whites suggesting that they believed that fate, luck, or chance were responsible for their health. I would have expected that incontinent women who scored high on internal and chance health locus of control scales to have reported less utility for incontinence care seeking as responsibility for their health status becomes internalized. Yet, Hispanic and Black survey respondents have a strong belief in powerful others seems to overwhelm alternative beliefs about health locus of control that drives utility of incontinence care seeking despite any need to internalize the responsibility for their health.

It is also possible that Black and Hispanic survey respondents who scored high on internal and chance health locus of control scales were more likely to use self-care or self-treatment strategies compared to survey respondents who scored lower on internal and chance health locus of control scales. Having tried and become less satisfied with these strategies, Hispanic and Black survey respondents could subsequently score high on powerful others health locus of control scales as a result of this self care experience, which subsequently drives their utility of incontinence care seeking. Whites who score low on internal or chance health locus of control scales may be less likely to try self-care or self-treatment strategies, seek professional care right away, and subsequently score low on powerful others health locus of control scales as a result of a negative professional care experience. This negative past experience with professional care may have driven their utility of incontinence care seeking in a direction opposite to Hispanic and Black survey respondents. These hypotheses remain untested because I did not test for differences in self-care or self-treatment strategy utilization between my three surveyed ethnic groups. My cross-sectional study design prevents any analysis of causation using structural equation modeling.

Marital status did differ between my three surveyed ethnic groups. Blacks were more likely to be unmarried, compared to White, and Hispanic survey respondents. Therefore Black survey respondents did not likely receive the same social support from their spouse that appears to encourage incontinence care seeking compared to White and Hispanic survey respondents.

Blacks and Hispanics were more likely to see their physician annually compared to Whites despite similarities in incontinence symptom severity, socioeconomic status,

and barriers to care. This finding may be related to the increased prevalence of co-morbidities in members of these two ethnic groups.

As a group, ethnic minorities are more likely to report co-morbidities compared to majority populations for a number of reasons including access to health care differences. Baker found that ethnic minority status was independently associated with poor health and increased likelihood of condition specific care seeking compared to Whites after adjusting for socioeconomic (housing tenure), demographic (age), and lifestyle (smoking) variables. Baker found that ethnic minority group status was associated with a higher likelihood of depression (OR 2.02, 95% CI 1.34, 3.04), diabetes (OR 4.03, 95% CI 2.54, 6.39), migraine (OR 1.72, 95% CI 1.26, 2.35) and minor respiratory symptoms (OR 1.75, 95% CI 1.33, 2.29) compared to their White counterparts. Ethnic minorities were more likely to seek general practitioner consultation for backache (OR 3.28, 95% CI 2.06, 5.21), indigestion (OR 2.94, 95% CI 1.53, 5.65), migraine (OR 3.22, 95% CI 1.75, 5.93), minor respiratory symptoms (OR 3.53, 95% CI 2.26, 5.50), and sleep problems (OR 4.72, 95% CI 2.56 to 8.71) than their White counterparts [Baker 2002].

Yet, the increased frequency of annual physician visits, or the possibility of increased co-morbidities for Blacks and Hispanics compared to Whites could not confound the relationship between ethnicity and incontinence care seeking because I found no association between frequency of physician visits and incontinence care seeking. Additionally, more co-morbidities in Black and Hispanic survey respondents would likely increase, not decrease incontinence care seeking rates for Black and Hispanic survey respondents compared to White survey respondents with less co-morbidities.

Discussions about urinary incontinence during a patient/physician interaction require two discussants. Women who are seeing their physician to attend to co-morbidities have the opportunity to ask questions about their incontinence symptoms. Physicians also have the opportunity to ask their female patients about incontinence especially when patients are unwilling to discuss these issues. Co-morbidities and physician visit frequency should be leveraged by interventions designed to improve the incontinent patient and physician interaction from each person's perspective.

Hypothesis 4 Clinical and demographic variables, excluding ethnicity, and psychosocial variables explain any significant association between ethnicity and incontinence care seeking.

Consistent with the Theory of Care Seeking Behavior, habits was the only psychosocial variable that remained an independent predictor of incontinence care seeking when it was simultaneously entered into my model with clinical and demographic variables. Clinical and demographic variables, excluding ethnicity, (incontinence type, pads worn per day, impact of urinary incontinence on activities of daily living, and symptom change since onset) remained independent predictors of incontinence care seeking when they were simultaneously entered into my model with psychosocial variables. Yet none of these independent predictors of incontinence care seeking explained the association of ethnicity with incontinence care seeking. Ethnicity remained an independent predictor of incontinence care seeking when it was simultaneously entered into my model with psychosocial, and other clinical and demographic variables. Social norms, preventive health behaviors, and marital status

were no longer independent predictors of incontinence care seeking when they were simultaneously entered into my model with psychosocial, and clinical and demographic variables, including ethnicity.

Measures of incontinence severity including, incontinence type, and pads worn per day were independent predictors of incontinence care seeking when they were simultaneously entered into my model with psychosocial variables, and ethnicity.

Incontinence type predicted incontinence care seeking in the expected direction. Incontinent survey respondents who reported urge urinary incontinence were almost six and one half times as likely to seek incontinence care compared to survey respondents who reported stress urinary incontinence. This finding is consistent with reports from the medical literature suggesting that women with urge urinary incontinence have a greater psychosocial impact from their disorder compared to women with stress urinary incontinence related to the increased in severity and unpredictability of accidents associated with urge urinary incontinence.

Incontinent survey respondents who reported wearing 3 or more pads per day were seven times as likely to seek incontinence care compared to survey respondents who reported not wearing any pads.

I believe that these measures of incontinence severity may have overwhelmed social norms, marital status, and preventive health behaviors as predictors of incontinence care seeking. When symptoms are severe, affected individuals may be less likely to rely on significant others, including husbands, actual or perceived beliefs about care seeking, or preventive health behaviors, when deciding on care seeking.

Individuals likely use measures of incontinence severity during the initial illness appraisal process to establish that their symptoms deviate from their personal health “norm”. As part of this appraisal process, individuals with severe symptoms are more likely to identify incontinence as illness rather than their personal health “norm” compared to individuals with mild symptoms. This symptom severity self assessment is vital for determining the appropriate “next step”. For incontinent women with severe symptoms, this may mean seeking incontinence care right away compared to taking a wait and see approach, or the use self care or self treatment strategies when symptoms are milder.

Yet this illness appraisal process does not explain the percentage of individuals with severe symptoms who do not seek care or individuals with mild symptoms who seek care right away. This apparent paradox has previously been explained by the degree of symptom “bothersomeness.” Individuals with mild symptoms may be significantly “bothered” by their symptoms because self care or self treatment strategies have failed. They may seek care right away compared to individuals with severe symptoms who are not “bothered” by their symptoms. Conversely, less “bothered” individuals with severe symptoms may take a wait and see approach or not seek care at all because self care or self treatment strategies have worked. The relationship between outcomes of self care or self treatment strategies, bothersomeness, and incontinence care seeking, have not been studied yet.

Visual analog scales have previously been used to measure the general “bothersomeness” of symptoms independent of measures of incontinence severity. Yet measuring the general “bothersomeness” of symptoms may be a simplified approach to

measuring the impact that symptoms have on the affected individual's activities of daily living. A general measure of bothersomeness may be difficult to qualify for an affected individual who struggles to determine "what bothersomeness looks like." In fact bothersomeness is likely to look differently to each affected individual. Are two incontinent women with bothersomeness scores of 8 equally bothered by their symptoms? To date, I have been unable to identify studies that have established factors which explain "bothersomeness" to incontinent individuals.

Regardless of how "bothersomeness" is defined, I still remain unable to explain the 50% of affected individuals who report "significant" incontinence, are bothered by their symptoms, yet still do not seek care. It is possible that a general bothersomeness scale does not capture the same salient factors as well as measures of impact of urinary incontinence on activities of daily living in explaining incontinence care seeking. In my study, incontinent survey respondents who reported a high impact of urinary incontinence on activities of daily living were almost four times as likely to seek incontinence care compared to survey respondents who reported a low impact of urinary incontinence on activities of daily living. The association between the impact of urinary incontinence on activities of daily living with incontinence care seeking likely explains why I was unable to retain Sandvik's incontinence severity index in my model to test hypothesis 3.

Based on the results of my study, I hypothesize that measures of incontinence severity including incontinence type, pads worn per day, and symptom change since onset likely co-vary with impact of urinary incontinence on activities of daily living in explaining incontinence care seeking directly or indirectly through habits. Sanitary pads are one of the self care strategies used by incontinent women to conceal their symptoms

from society in an attempt to prevent them from being ostracized. The embarrassment of detectable urine odor and/or the economic burden of this self care strategy may have a direct effect on incontinence care seeking, independent of health care habits.

Alternatively, pads worn per day may have an indirect affect on care seeking through habits, if and only if an affected individual has the habit of seeking care when faced with symptoms.

Like pads worn per day, I suggest that incontinence type has a direct effect on incontinence care seeking. Alternatively incontinence type may have an indirect affect on incontinence care seeking, through habits, if and only if an affected individual has the habit of care seeking when faced with symptoms.

Survey respondents who reported that their symptoms were unchanged or worse since their onset were less likely to seek incontinence care compared to survey respondents who reported that their symptoms were better since its onset. The most obvious explanation for this paradox is that survey respondents were providing female interviewers with socially acceptable responses as a result of incontinence care seeking rather than as a salient predictor of care seeking behavior. For example, survey respondents who reported that their symptoms were better, did so likely as a result of incontinence care seeking compared to survey respondents who reported that their symptoms were unchanged or worse as a result of not seeking care. This is the only indication I received suggestive of a bi-directional (non-recursive) path between measures of incontinence severity and incontinence care seeking. As incontinence providers, we should be reassured by these findings because any effort to identify predictors of incontinence care seeking would be inconsequential if professional

diagnosis and treatment did not improve symptoms post onset. Nonetheless I was unable to determine if care seeking resulted in improved symptoms in my hypothesized model because my survey was cross-sectional in design.

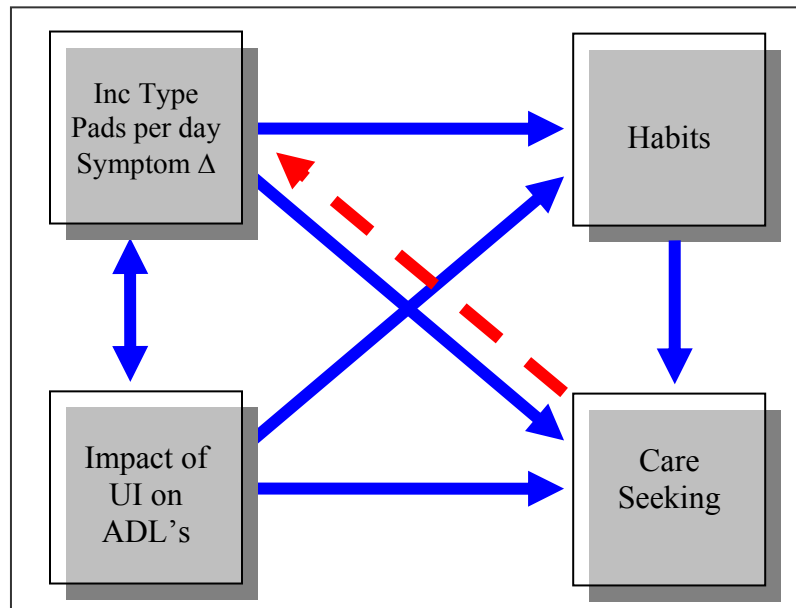

Figure 8. Hypothesized causal model for incontinence care seeking

None of my measured psychosocial variables (habit, social norms, affect, utility), or clinical and demographic variables (marital status, symptom change since onset, incontinence type, pads worn per day, impact of urinary incontinence on activities of daily living, and preventive health behaviors) could explain ethnic differences in incontinence care seeking rates when ethnicity was entered simultaneously into my model. Differences in incontinence care seeking between my ethnic groups could not be explained by differences in socioeconomic status because I stratified my three ethnic groups by socioeconomic status during the recruitment of survey respondents.

The answers to two questions are vital for public health policymakers in their attempts to minimize health disparities for all incontinent women in the United States. The first question is, “why do Black and Hispanic survey respondents seek incontinence care at lower rates compared to White survey respondents?”

Clearly, unmeasured predictor variables may explain the ethnic differences in incontinence care seeking rates found in my study. Unmeasured predictor variables such as religiosity, spirituality, cultural beliefs, co-morbidities, healthcare system prejudice and negative stereotypes, or personal trust in the healthcare delivery system may have differed between my three ethnic groups thereby introducing confounding bias that may threaten the validity of my conclusions.

In 1999, Congress requested that the Institute of Medicine assess the possibility that ethnic minorities receive lower quality healthcare than whites even when healthcare access-related factors including the availability of health insurance and ability to pay for care are similar. The Institute of Medicine concluded that bias, prejudice, and stereotyping of ethnic minorities by healthcare providers may contribute to differences in health care.

According to the Institute of Medicine, stereotyping is defined as the process by which people use social categories like race or sex in acquiring, processing, and recalling information about others. These stereotypes help organize and simplify complex situations, and give people greater confidence in understanding a situation to respond in effective ways [Institute of Medicine 2002]. Prejudice or bias is defined as unjustified negative attitude based on a person’s group membership.

Conscious or overt negative racial stereotyping and prejudice towards ethnic minorities is easily identified and should be discouraged by the health care delivery system and all other service industries. Subconscious or covert negative racial stereotyping and prejudice towards ethnic minorities is more difficult to identify making it more troublesome for the health care delivery system to discourage. Subconscious or covert negative stereotyping and prejudice towards ethnic minorities exist and certainly affects the quality of healthcare delivered.

Diagnostic test and treatment decisions may be influenced by a provider's feelings towards patients whose ethnicity differs from their own. White physicians rate black patients as less intelligent, less educated, more likely to abuse drugs and alcohol, and more likely to fail to comply with medical advice, more likely to lack social support, and less likely to participate in cardiac rehabilitation compared to white patients, after controlling for socioeconomic status [Institute of Medicine 2002].

Ethnic minorities' response to this negative stereotyping and prejudice is predictable. Minority patients perceive higher levels of racial discrimination by health care entities compared to non-minorities resulting in mistrust, refusal of treatment, and poor treatment compliance. In a vicious cycle of reciprocity, providers may become less invested in the treatment process, and may be less likely to provide diagnostic or treatment services to their mistrusting and poorly compliant patients.

Johnson conducted a cross sectional telephone survey of 6,299 adults living in the United States to test the hypothesis that racial and ethnic differences exist in a patient's perceptions of physician's bias and cultural competence during a patient physician interaction. They similarly hypothesized that racial and ethnic differences exist

in a patient's perceptions of healthcare system bias and cultural competence during an interaction at the healthcare system level. Cultural competence at the physician level was defined as the ability of physicians to establish effective interpersonal and working relationships with patients that supercede cultural differences. Cultural competence at the healthcare system level was defined as the ability of health care providers and health care organizations to understand and respond effectively to the cultural and linguistic needs of patients during the healthcare encounter. Ethnic differences in patient perceptions of physician bias and cultural competence were explained by age, socioeconomic status, health literacy, and source of care, for all minority groups except Asian respondents. Asian respondents perceived that physicians looked down on them and the way they lived their lives. The researchers found that racial and ethnic minority survey respondents perceived bias and lack of cultural competence at the healthcare system level compared to whites after adjusting for age, socioeconomic status, health literacy, self rated health status, source of care, and reports of medical communication. Ethnic minority group perceptions of health care system bias and cultural incompetence may contribute significantly to the health care disparities in existence today [Johnson 2004].

Bogart surveyed 59 Black women to test the hypothesis that individuals who perceived physicians positively had greater healthcare utilization, greater healthcare satisfaction, and had greater intentions to seek health professional help in the future, compared to individuals who perceived physicians negatively. Furthermore, they hypothesized that these negative stereotypes of physicians arose from perceptions of previous discrimination during health encounters. Overall physicians were perceived positively. Survey respondents who perceived physicians positively had visited health

care providers more frequently, reported a greater number of health care visits in the past year, and were more satisfied with their health care compared to individuals who had negative stereotypic beliefs. They found no relationship between perceived racism and healthcare utilization, intentions, or satisfaction. The investigators recognized that they were unable to establish the direction of the relationship between stereotypic beliefs and healthcare utilization. intentions, or satisfaction. It is also plausible that individuals who had visited healthcare providers more recently, more frequently, and were more satisfied, developed more positive feelings towards their physicians compared to individuals who did not utilize the healthcare system [Bogart 2001].

A culture group is defined as a collection of individuals that share common beliefs, ideas, experiences, knowledge, attitudes, and behaviors. For example, physicians and patients may have differing explanations for a health disorder like urinary incontinence because of differing backgrounds. When mutual respect for these two distinct cultures exists, appropriate use of health care services, compliance with therapeutic interventions, and improved health outcomes can be realized, even when explanations differ. This is an example of a culturally sensitive patient physician interaction.

A culturally sensitive health care system acknowledges that health and disorder beliefs and behaviors are dependent on ethnic values, cultural orientation, religious beliefs, linguistic considerations, and avoids labeling or stereotyping. It is a system that also is sensitive to within cultural group variations in health and disorder beliefs and behaviors.

Nevertheless, individuals who hold negative stereotypic beliefs about physicians may be reluctant to visit a physician for relatively minor medical complaints and delay care seeking until their problems become severe. Negative stereotypes, like the perception of bias and cultural competence at the healthcare system level, likely contributes to health disparities for ethnic minorities.

A lay illness is a disorder whose etiology, presentation, diagnosis, or treatment, does not fit into any biomedical disease category. Ethnic minorities may be more likely to consider urinary incontinence as one of many lay illnesses worthy of lay treatments rather than formal treatment, compared to their incontinent White counterparts. Empacho is a lay illness caused by intestinal obstruction from dietary indiscretion described by Puerto Rican, Mexican American, and Central Americans. The last treatment option for affected individuals before symptom resolution consisted of home based remedies in 23% of cases, a visit to a *santiguadora* (healer) in 68% of cases, and a trip to a physician in only 9% of cases. “Falling out” in Blacks and *ataque de nervios* in Puerto Ricans are two other common lay illnesses that are often treated by root workers in the case of Blacks, or *espiritista* in Puerto Ricans [Pachter 1994].

I did ask survey respondents if they felt that uncontrollable urine leakage was a medical problem. I found no association between the identification of urinary incontinence as a medical problem and increasing incontinence care seeking for formal diagnosis and treatment. However, I have no data on what percentage of women in either group considered their symptoms a lay illness necessitating alternative forms of treatment.

Measuring and adjusting for these potential confounders may explain the independent association of ethnicity on incontinence care seeking found in my study. Unlike ethnicity, these potential confounders may be modified by interventions aimed at increasing the percentage of all incontinent women who seek care. See Figure 9.

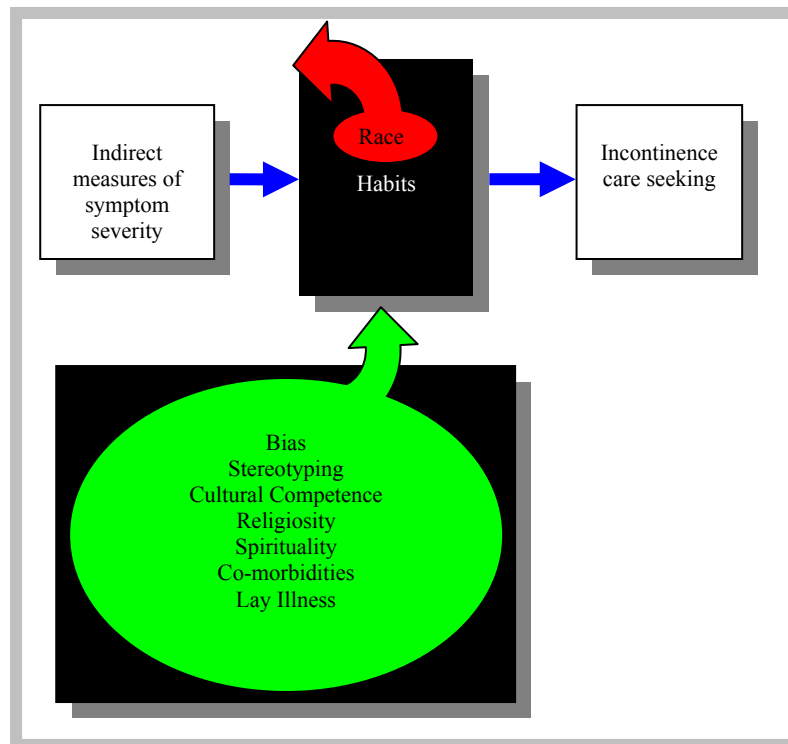

Figure 9. Unmeasured Variables Hypothesized to Explain the Association of Ethnicity on Incontinence Care Seeking

Just because each of the measured psychosocial, barrier, and clinical and demographic variables from my study did not explain between ethnic group differences for incontinence care seeking does not mean that they are inconsequential in explaining within ethnic group differences in incontinence care seeking. This brings us to my second question.

The second question is “which combinations of measured psychosocial, barrier, and clinical and demographic variables are salient to explaining within ethnic group differences in incontinence care seeking?” The primary objective of my study was to determine if ethnicity was an independent predictor of incontinence care seeking, after adjusting for other clinical and demographic, psychosocial, and barrier variables. Therefore race was entered into my regression analyses in the traditional manner which assumes that other clinical and demographic, psychosocial, and barrier variables are the same for each of the ethnic groups under study. In fact the parameter estimates for each of these potentially confounding variables reflect the additive differences between these ethnic groups resulting in their elimination as independent predictors of incontinence care seeking. When various outcomes, like incontinence care seeking, are assessed within ethnic groups, different causal pathways emerge providing investigators with further insight into the parsed contributions of each of the measured variables in my study in explaining incontinence care seeking for that specific ethnic group [Wolinsky 1990].

To answer this question, I will need to recruit a greater number of care seeking and non-care seeking incontinent survey respondents within each ethnicity group. This will allow us to test the null hypothesis that my final explanatory model does not differ between White, Black, or Hispanic survey respondents. For example, variables such as utility of incontinence care seeking, health locus of control, marital status, physician exam frequency, and incontinence type that differed between my three ethnic groups, may be among the many measured variables that predict incontinence care seeking when within ethnic group comparisons of incontinent Whites, Blacks, and Hispanics are conducted. Barriers may interact with incontinence type negating the increased

likelihood of incontinence care seeking associated with urge urinary incontinence for Blacks.

The Theory of Care Seeking Behavior provides a suitable framework for exploring the parsed contributions of both measured clinical and demographic, psychosocial, and barrier variables, and potential confounders including bias, stereotyping, cultural competence, religiosity, and spirituality for explaining within and between ethnic group differences in incontinence care seeking. The rationale behind the choice of the Theory of Care Seeking Behavior over other behavioral models for explaining incontinence care seeking was based on clinical observation. As a clinician, I did not detect a strong correlation between age, symptom severity, and incontinence care seeking in my patient population. Furthermore, I could not personally reconcile reports of ethnic differences in incontinence type, obstetric-induced perineal trauma, or urethral resistance from tertiary care centers without considering differences in access to care. The behavioral model chosen for my study had a proven track record for identifying ethnicity as an independent predictor of health care seeking which may partially explain the healthcare disparities that exist in the United States today.

I caution researchers about drawing conclusions about ethnic differences in incontinence type without considering access to care disparities. It would be plausible to conclude that Blacks are affected by urge urinary incontinence more frequently than Whites when the sampling frame is not considered. Barriers may be an important predictor of incontinence care seeking for Blacks and not an important predictor for Whites. Investigators who recruit survey respondents from lists of health maintenance organization (HMO) enrollees or primary care physician offices may introduce selection

bias into their research because of a disregard for access to care differences. These studies are likely to differentially recruit more Whites reporting stress urinary incontinence and more Blacks with urge urinary incontinence because of the greater psychosocial effects and impact that urge urinary incontinence has on activities of daily living. Blacks with urge urinary incontinence are more likely to overcome barriers to care seeking compared to Blacks with stress urinary incontinence. Whites with stress urinary incontinence are likely to seek care more frequently than Blacks with stress urinary incontinence because they have fewer barriers to care.

There are several limitations to my study that must be considered before any of my conclusions can be accepted. I minimized the cultural heterogeneity of health and disorder beliefs and behaviors within each ethnic group by categorizing ethnicity as White, Black, and Hispanic. Previous research has shown differences in the use of health services by Puerto Ricans, Cuban Americans, and Mexican Americans. For example, Cuban Americans are the most acculturated Hispanics emigrating from their country of origin with professional job training. Comparatively, Puerto Rican and Mexican Americans are typically employed in more physically demanding jobs with low pay and limited benefits. Potential predictors of incontinence care seeking such as ethnic identification, time period and circumstances surrounding immigration, and acculturation status would remain undetected when Puerto Rican, Cuban Americans, and Mexican Americans are grouped as Hispanic Americans.

The unwillingness of the least acculturated Hispanics to participate in my survey provides an example of how homogeneity within ethnic groups may limit the external validity of my findings to the most acculturated survey respondents. The least

acculturated survey respondents are those individuals who 1) are recent immigrants to the mainland United States, 2) who live in ethnic enclaves, 3) who prefer to use their native tongue, 4) were educated in their country of origin, 5) who migrate back and forth to their country of origin, and 6) who are in constant contact with older individuals within their ethnic group who maintain a high degree of ethnic identity. These least acculturated individuals may have different ethno-cultural health and disorder beliefs and behaviors compared to their most acculturated survey respondents [Pachter 1994].

I may have introduced selection bias into my study by not validating Spanish versions of my survey that could be administered to the least acculturated Hispanics whose health and disorder beliefs and behaviors likely differ from more acculturated survey respondents. The homogeneity of my ethnic group survey respondents likely reduced my parameter estimate variability hindering the identification of clinical and demographic, psychosocial, and barrier predictors of incontinence care seeking. The identification of ethnicity as an independent predictor of incontinence care seeking would argue against this possibility.

Survey respondents had to report urinary incontinence in the past 12 months to be eligible for participation. Survey respondents may have been misclassified as to their incontinence care seeking behavior because the source of the data was based only on self report. Survey respondents may have provided interviewers with the socially acceptable response (sought care) given the duration of their symptoms. However this is unlikely given my incontinence care seeking rate of 27.6% which is consistent with other prevalence rates reported in the medical literature. I would expect to have found an

inflated prevalence rate compared to other reported rates if survey respondents were misclassified based on self report.

Misclassification bias may also have been introduced because of the question used to ascertain my incontinence care seeking rates. “Have you sought care for uncontrollable urine leakage from a health practitioner, over the last 12 months?” does not preclude survey respondents who had sought incontinence care 12 months prior to the survey, from responding “no (not sought care).” Again, this is unlikely for two reasons. First, the question was asked in conjunction with the survey eligibility question “have you noticed uncontrollable urine leakage over the past 12 months?” Second, my incontinence care seeking rates are again consistent with reported rates in the medical literature suggesting that misclassification bias did not lead to an underestimated care seeking rate.

By limiting my study to women who experienced uncontrollable urine leakage over the past 12 months, I may have introduced selection bias by excluding women who had sought care prior to my 12 month threshold and were cured of their disorder by formal treatment. If selection bias was introduced I would expect my incontinence care seeking rates to be underestimates of actual care seeking rates. I could have minimized selection bias by ascertaining about incontinence care seeking prior to 12 months ago before excluding survey candidates who denied urinary incontinence.

My final model explained 40.8% of the variance for incontinence care seeking, yet unmeasured predictor variables may affect the strength of the associations found in my study because of confounding bias. For example, I did not collect data on prior medical or surgical treatments for urinary incontinence suggestive of incontinence care

seeking prior to my twelve month threshold. An unknown proportion of survey respondents may have been included in my survey that have experienced recurrent urinary incontinence because of surgical or medical treatment failures. Survey respondents who experience recurrent urinary incontinence may respond differently to care seeking questioning compared to respondents with primary disease. Specifically, survey respondents who report recurrent urinary incontinence despite previous surgical or medical treatment may be less likely to report incontinence care seeking in the past 12 months, or have lower social norms scores, low utility of incontinence care seeking scores, and more negative affect compared to survey respondents with primary urinary incontinence.

I did not measure co-morbidities, and use of self care or self treatment strategies for urinary incontinence in my survey respondents. It is possible that the differences in incontinence care seeking rates between my ethnicity groups may be confounded by differences in co-morbidities that would differentially increase overall care seeking rates for affected individuals. Confounding bias associated with unmeasured co-morbidities was unlikely to affect the association between ethnicity and incontinence care seeking in my research. First, the mean age of my three race/ethnic groups were similar. Second the socioeconomic status and barriers reported by respondents in each ethnic group were similar theoretically providing equal access to health care. Even if co-morbidities were higher in Black and Hispanic survey respondents than age and socioeconomic status matched Whites, these differences could not explain why affected minorities sought less incontinence care despite higher utility for incontinence care seeking, similar health

insurance coverage, and similar barriers to incontinence care seeking than their White counterparts.

I chose not to collect data on self care or self treatment strategies used by my incontinent survey respondents. Therefore I was unable to determine if utilization of self care or self treatment strategies mediated the relationship between disorder appraisal and care seeking. For example, positive outcomes after successful self care or self treatment may have a direct effect on incontinence care seeking and confound the association of clinical and demographic, and psychosocial variables on care seeking behavior. Alternatively, positive outcomes after successful self-care or self-treatment may have an indirect effect on incontinence care seeking through unmeasured variables including mastery, self efficacy, and optimism each of which themselves may add to confounding bias. I would expect negative outcomes after unsuccessful self-care and self-treatment to have similar associations with incontinence care seeking, yet opposite effects.

The validity of telephone surveys is threatened by non-coverage and nonresponse bias. Women with high socioeconomic status may be overrepresented in households with unlisted numbers making it difficult to recruit these individuals from purchased phone bank lists. However, random digit dialing should have overcome this limitation. Women in lower socioeconomic status groups are overrepresented in non-telephone households. Random digit dialing cannot overcome non-telephone coverage making it likely that women in higher socioeconomic status groups will be differentially recruited over women in lower socioeconomic status groups with this technique. However, in his review of the 1980 Health Interview Survey, Marcus found only small differences in selected demographic characteristics when comparing non-telephone to telephone

households. In only 3 cases did estimates differ by more than 1% and in no cases did estimates differ by more than 2% [Marcus 1986].

Compared to in-person interviews, telephone surveys tend to have 10-20% lower response rates subjecting the study to nonresponse bias. To determine the impact of nonresponse bias, two researchers compared sociodemographic characteristics in initial respondents to nonrespondents who were recontacted, and persuaded to participate. The two groups differed in occupation, education, income, race, country of ancestry, and housing status. Despite these sociodemographic differences, none of the differences in the estimated population parameters exceeded 2% [Marcus 1986].

While non-telephone coverage and nonresponse bias may not individually produce large systematic errors in calculating parameter estimates, their combined effect may be great. However, areas that have low telephone coverage and nonresponse rates are the same areas that have high nonresponse rates to in-person interviews, which effectively eliminates the differential advantage of an in-person interview technique.

My purposive sampling technique was designed to minimize any systematic errors that could threaten the validity of my telephone survey from non-telephone coverage and nonresponse bias. Purposive sampling was used to include respondents with traditionally less telephone coverage and higher nonresponse rates because it allowed us to recruit survey respondents with low socioeconomic status scores within each ethnic minority group. Despite my attempts to recruit survey respondents with a wide range of socioeconomic status scores, my purposive sampling technique produced a platykurtic sample population around a mean of 30. Therefore it is unlikely that

incontinent women with extremely low or high socioeconomic scores were adequately recruited as survey respondents.

Ideally, data collection should be conducted with a completely separate sample population from the one used to validate my measurement models. This was not possible in my study because of my small sample size.

This study had limited power to detect differences in psychosocial and barrier variables from the Theory of Care Seeking Behavior or previously established predictor variables from the medical literature for care seekers compared to non-seekers. Similarly, this study had limited power to detect potential covariates of the relationship between ethnicity and incontinence care seeking. I powered my study to be 95% confident that my sample estimates were within 7% of the population estimates.

However, a secondary objective of this study phase was to obtain pilot data to estimate sample size requirements for a nationwide CATI. Based on these sample size estimates, a probability sample will be obtained using a random digit dialing technique so my findings can be generalized to a United States ethnically heterogeneous incontinent female population.

In summary, ethnicity was an independent predictor of incontinence care seeking, after adjusting for socioeconomic status, psychosocial and barrier variables as directed by the Theory of Care Seeking Behavior. Hispanic and Black survey respondents sought incontinence care at lower rates than White survey respondents despite similar measures of symptom severity. None of the measured psychosocial, clinical, or sociodemographic variables explained the association of ethnicity on incontinence care seeking. Further research is needed to identify modifiable confounders capable of explaining the

association between ethnicity and incontinence care seeking if I hope to reduce health disparities in the diagnosis and treatment of urinary incontinence for all incontinent women.

REFERENCES

- Abrams P., et al. (2002). The Standardisation of Terminology of Lower Urinary Tract Function: Report from the Standardization Sub-Committee of the International Continence Society. *Neurmyol Urodyn.* 21, 167-178.
- Ashworth, P.D., Hagan, M.T. (1993). The Meaning of Incontinence: a Qualitative Study of Non-Geriatric Urinary Incontinence Sufferers. *Jmynal of Advanced Nursing* 18, 1415-1423.
- Bailey, E. (1987). Sociocultural Factors and Health Care-Seeking Behavior among Black Americans. *J of the National Med Assoc* 79, 389-392.
- Baker, D., Mead, N., Campbell, S. (2002). Inequalities in Morbidity and Consulting Behavior for Socially Vulnerable Groups. *Br J General Practice.* 52, 124-130.
- Bazargan, M., Bazargan, S., and Baker, R. (1998) Emergency Department Utilization, Hospital Admissions, and Physician Visits Among Elderly Black Persons. *The Gerontologist* 38 (1), 25-36.
- Bogart, L.M. (2001). Relationship of Stereotypic Beliefs About Physicians to Health Care-Relevant Behaviors and Cognitions Among Black Women. *J of Behavioral Medicine.* 24(6), 573-586.
- Brocklehurst JC. (1993) Urinary Incontinence in the Community – Analysis of a MORI poll. *Br Med J.* 306, 832-834.
- Bump RC. (1993) Racial comparisons and contrasts in urinary incontinence and pelvic organ prolapse. *Obstet and Gynecol* 81(3), 421-5.
- Burgio KL, I., Diane G, Locher, J., Arena, V., Kuller, L. (1994). Treatment Seeking for Urinary Incontinence in Older Adults. *JAGS.* 42, 208-212.
- Burgio KL, Matthews KA, Engel BT. (1991). Prevalence, Incidence and Correlates of Urinary Incontinence in Healthy, Middle-Aged Women. *J Urol.* 146, 1255-1259.
- Byrne, B. (Eds.). (2000). *Structural Equation Modeling with Amos: Basic Concepts, Applications, and Programming (Multivariate Application Series)*. Mahwah, NJ: Lawrence Erlbaum Associates, Inc.

- Cameron, L., Leventhal, E., and Leventhal, H. (1993). Symptom Representations and Affect as Determinants of Care Seeking in a Community-Dwelling, Adult Sample Population. *Health Psychology* 12 (3), 171-179.
- Chiverton, P.A., Wells, T.J., Brink, C.A., Mayer, R. (1996). Psychological Factors Associated with Urinary Incontinence. *Clin Nurse Spec* 10 (5), 229-233.
- Cleary, P.D., Jette, A.M. (1984) The Validity of Self-reported Physician Utilization Measures. *Med Care* 22 (9), 796-803.
- Diokno AC, Brock BM, Brown MB, Herzog AR. (1986) Prevalence of Urinary Incontinence and Other Urological Symptoms in the Noninstitutionalized elderly. *J Urol*, 136: 1022-1025,.
- Dugan, E., et al. (2001). Why Older Community-Dwelling Adults Do Not Discuss Urinary Incontinence with Their Primary Care Physicians. *J AM Geriatr Soc* 49, 462-465.
- Duong, T.H., Korn A.P. (2001). A Comparison of Urinary Incontinence Among Black, Asian, Hispanic, and White Women. *Am J Obstet Gynecol* 184 (6), 1083-1086.
- Frank-Stromberg, M., Olsen, S. J. (Eds.) (1992) *Instruments for Clinical Health-Care Research*. 2nd edition, Boston, MA: Jones and Bartlett Publishers.
- Goldstein, M., Hawthorne, M.E., Engelberg, S., McDowell, B.J., and Burgio KL. (1992) Urinary Incontinence: Why People Do Not Seek Help. *Jmynal of Gerontological Nursing* 18 (4), 15-20.
- Gonzalez-Swafford, M., Gutierrez, M. (1983) Ethno-Medical Beliefs and Practices of Mexican-Americans. *Nurse Pract* 29-34.
- Green, L.W. (1970). Manual for Scoring Socioeconomic Status for Research on Health Behavior. *Public Health Reports* 85(9), 815-827.
- Hagglund D., Walker-Engstrom, M.L., Larsson, G., Leppert, J. (2001). Quality of Life and Seeking Help in Women with Urinary Incontinence: A Population-Based Study. *Acta Obstet Gynecol Scand* 80, 1051-1055.
- Hagglund, D., Walker-Engtrom, M.L., Larsson, G. Leppert, J. (2003). Reasons Why Women with Long-Term Urinary Incontinence Do Not Seek Professional Help: a Cross-Sectional Population-Based Cohort Study. *Int Urogynecol J*. 14, 296-304.
- Hannestad, Y.S., Rortveit, G, Sandvik, H., Hunskaar, S. (2000). A Community-Based Epidemiological Survey of Female Urinary Incontinence: The Norwegian EPINCONT Study. *J of Clinical Epidemiology*. 53, 1150-1157.
- Harlow, B., Rosenthal, J., Ziegler, R. (1985) A Comparison of Computer-Assisted and Hard Copy Telephone Interviewing. *Am J of Epid*. 122, 335-340.

- Heymen, S. (2004). Psychological and Cognitive Variables Affecting Treatment Outcomes for Urinary and Fecal Incontinence. *Gastroenterology online*. 126(1), 1-9.
- Holst, K., and Wilson PD. (1988). The Prevalence Of Female Urinary Incontinence And Reasons For Not Seeking Treatment. *NZ Med J*. 101, 756-758.
- Howard D. Delancey JO. Tunn R. Ashton-Miller JA. (2000) Racial differences in the structure and function of the stress urinary continence mechanism. *Obstet and Gynecol*. 95(5), 713-7.
- Hunnskaar, S. Vinsnes, A. (1991). The Quality of Life in Women with Urinary Incontinence as Measured by the Sickness Impact Profile. *JAGS*. 39, 378-382.
- Hunnskaar, S., Arnold E.P., Burgio, K., Diokno, A.C., Herzog A.R., Mallett, V.T. (2000). Epidemiology and Natural History of Urinary Incontinence. *Int Urogynecol J*. 11, 301-319.
- Institute of Medicine. (2002). *Unequal Treatment: What Healthcare Providers Need to Know About Racial and Ethnic Disparities in Health Care*. Washington, D.C., Institute of Medicine.
- Jackson, R.A., et al, for the Health, Aging, and Body Composition Study. (2004). Urinary Incontinence in Elderly Women: Findings From the Health, Aging, and Body Composition Study *Obstet Gynecol* 104, 301-307.
- Jacobsen, SJ, Chute, CG, Girman, CJ, Oesterling, JE, Guess, HA, Lieber, MM, and Panser, L. (1995). Do Prostate Size and urinary Flow Rates predict Health Care-Seeking Behavior for Urinary Symptoms in Men? *Urology*. 45 (1), 64-69.
- Jacobsen, SJ, Guess, HA, Panser, L, Girman, CJ, Chute, CG, Oesterling, JE, and Lieber, MM. (1993) A Population-Based Study Of Health Care-Seeking Behavior For Treatment Of Urinary Symptoms - The Olmstead County Study Of Urinary Symptoms And Health Status Among Men. *Arch Fam Med*. 2, 729-735.
- Jacobson, A. (1995) Health-Care-Seeking Behavior: Implications for the Primary Care Physician. *Psychosomatic Medicine*. 57, 48-49.
- Jeter, K.F., Wagner D.B. (1990). Incontinence in the American Home: A Survey of 36,500 People. *JAGS*. 38 (3), 379-383.
- Johnson, R.L., Saha, S., Arbelaez J.J., Beach, M.C., Cooper, L.A. (2004). Racial and Ethnic Differences in Patient Perceptions of Bias and Cultural Competence in Health Care. *J Gen Intern Med*. 19, 101-110.
- Kinchen, K.S., Burgio, K., Diokno, A.S., Fultz, N.H., Bump, R. Obenchain, R. (2003). Factors Associated with Women's Decisions to Seek Treatment for Urinary Incontinence. *J of Women's Health*. 12(7), 687-698.

- Kline, R. (Eds.). (1998). *Principles and Practice of Structural Equation Modeling*. New York, NY: The Guilford Press.
- Lagace EA, Hansen W, Hickner JM. (1993). Prevalence and Severity of Urinary Incontinence in Ambulatory Adults; an UPRNet Study. *J Fam Pract.* 36, 610-614.
- Lagro-Janssen, T., Smits, A., Van Weel, C. (1990). Women With Urinary Incontinence: Self-Perceived Worries And General Practitioners' Knowledge Of Problem. *British Jmynal of General Practice.* 40, 331-334.
- Lauver, D., Angerame, M. (1993). Women's Expectations About Seeking Care For Breast Cancer Symptoms. *Oncology Nursing Forum.* 20 (3), 519-525.
- Lauver, D., Nabholz, S., Scott, K., and Tak, Y. (1997). Testing Theoretical Explanations of Mammography Use. *Nursing Research.* 46 (1), 32-39.
- Lauver, D. (1992a). A Theory Of Care-Seeking Behavior. *Jmynal of Nursing Scholarship.* 24 (4), 281-288.
- Lauver, D. (1994). Care-Seeking Behavior with Breast Cancer Symptoms in White and African-American Women. *Research in Nursing & Health.* 17, 421-431.
- Lauver, D. (1992b). Psychosocial Variables, Race And Intention To Seek Care For Breast Cancer Symptoms. *Nursing Research.* 41 (4), 236-241.
- Locher J.L., Burgio, K.L., Goode, P.S., Roth, D.L., Rodriguez, E.R. (2002). Effects of Age and Causal Attribution to Aging on Health-Related Behaviors Associated with Urinary Incontinence in Older Women. *The Gerontologist.* 42 (4), 515-521.
- Malmsten, U., Milsom, I., Molander, U., and Norlen, L. (1997). Urinary Incontinence And Lower Urinary Tract Symptoms: An Epidemiological Study Of Men Aged 45 To 99 Years. *J Urology.* 158, 1733-1737.
- Marcus, A., Crane, L. (1986). Telephone Surveys in Public Health Research. *Med Care.* 24, 97-112.
- Melnyk, K.A.M. (1990). Barriers to Care: Operationalizing the Variable. *Nursing Research.* 39(2), 108-112.
- McGrother, C.W., et al. (2004). Storage Symptoms of the Bladder: Prevalence, Incidence, and Need for Services in the U.K. *BJU Int.* 93, 763-769.
- Miner, P.B. (2004). Economic and Personal Impact of Fecal and Urinary Incontinence. *Gastroenterology Online.* 126 supp(1), 1-9.

- Norcross, W.A., Ramirez, C., Palinkas, L.A. (1996). The Influence of Women on the Health Care-Seeking Behavior of Men. *Jmynal of Family Practice*. 43(5), 475-480.
- Norton PA, MacDonald, LD, Sedgwick, PM, and Stanton SL. (1988). Distress And Delay Associated With Urinary Incontinence, Frequency, And Urgency In Women. *BMJ* 297, 1187-1189.
- Pachter, L.M. (1994). Culture and Clinical Care: Illness Beliefs and Behaviors and Their Implications for Health Care Delivery. *JAMA*. 271(9), 690-694.
- Rea L, Parker R. (Eds.). (1997). *Designing and Conducting Survey Research; A Comprehensive Guide*. 2nd Edition ed. San Francisco, CA: Jossey-Bass Inc.
- Rekers, H, Drogendijk, AC, Valkenburg, H, and Riphagen, F. (1992). Urinary Incontinence In Women From 35 To 79 Years Of Age: Prevalence And Consequences. *European J of Ob/Gyn & Reprod Biology*. 43, 229-234.
- Reymert, J., Hunskaar, S. (1994). Why Do Only A Minority Of Perimenopausal Women With Urinary Incontinence Consult A Doctor? *Scand J Prim Health Care*. 12, 180-183,.
- Rizk, D.E.E., Shaheen, H., Dunn, T.E., and Hassan, M.Y. (1999) The Prevalence And Determinants Of Health Care-Seeking Behavior For Urinary Incontinence In United Arab Emirates Women. *Int Urogynecol J* 10, 160-165.
- Roberts, R., Jacobsen, S.J., Rhodes, T., Reilly, W.T, Girman, CJ, Talley, N., and Lieber, MM. (1998) Urinary Incontinence In A Community-Based Cohort: Prevalence And Healthcare-Seeking. *JAGS*. 46, 467-472.
- Roe, B., Doll, H., and Wilson, K. (1999). Help Seeking Behavimy And Health And Social Services Utilisation By People Suffering From Urinary Incontinence. *Int J of Nursing Studies*. 36, 245-253.
- Rogers, RG. (1992) Living and Dying in the U.S.A.: Sociodemographic Determinants of Death Among Blacks and Whites. *Demography*. 29, 287-303.
- Sampselle, C.M., Harlow, S.D., Skurnick, J., Brubaker, L., Bondarenko, I. (2002). Urinary Incontinence Predictors and Life Impact in Ethnically Diverse Perimenopausal Women. *Obstet Gynecol*. 100, 1230-1238.
- Sandvik, H., Kveine, E., and Hunskaar, S. (1993) Female Urinary Incontinence - Psychosocial Impact, Self Care and Consultations. *Scand J Caring Sci*. 7, 53-56.
- Sandvik, H., Hunskaar, S., Vanvik, A., Bratt, H., Seim, A., Hermstad, R. (1995) Diagnostic Classification of Female Urinary Incontinence : an Epidemiological Survey Corrected for Validity. *J Clin Epidemiol*. 48, 339-343.

- Sandvik H, Seim A, Vanvik A, Hunskaar S. (2000). A Severity Index for Epidemiological Surveys of Female Urinary Incontinence: Comparison with 48-Hmy Pad-Weighing Tests. *Neurmyol Urodynam.* 19, 137-145.
- Seim, A. Sandvik H., Hannestad, R., Hunskaar, S. (1995). Female Urinary Incontinence-Consultation Behavimy and Patient Experiences: an Epidemiological Survey in a Norwegian Community. *Family Practice.* 12(1), 18-21.
- Sze, E.H.M., Jones W.P., Ferguson J.L., Barker, C.D., Dolezal, J.M. (2002). Prevalence of Urinary Incontinence Symptoms Among Black, White, and Hispanic Women. *Obstet Gynecol.* 99, 572-575.
- Uebersax J, Wyman J, Shumaker S, McClish D, Fantl A. (1995) Short Forms to Assess Life Quality and Symptom Distress for Urinary Incontinence in Women: The Incontinence Impact Questionnaire and the Urogenital Distress Inventory. *Neurmyol Urodynam.* 14, 131-139.
- Waetjen, L.E., et al. (2003). Stress Urinary Incontinence Surgery in the United States. *Obstet Gynecol.* 101, 671-676.
- Wallston, K.A., Wallston, B.S., DeVellis, R. (1978). Development of the Multidimensional Health Locus of Control (MHLC) Scales. *Health Education Monographs.* 6(2), 160-170.
- Watson, D. Clark, L.A., Tellegen, A. (1988). Development and Validation of Brief Measures of Positive and Negative Affect: The PANAS Scale. *J Personality and Social Psychology.* 54, 1063-1070.
- Wilson L., Brown JS., Shin GP., Luc KO., Subak LL. (2001). Annual Direct Cost Of Urinary Incontinence. *Obstet and Gynecol.* 98(3), 398-406.
- Wolinsky, F. et al. (1990). Ethnic Differences in the Demand for Physician and Hospital Utilisation Among Older Adults in Major American Cities: Conspicuous Evidence of Considerable Inequalities. *The Milbank Quarterly.* 67(3-4), 412-448.
- Wrightson, KJ and Wardle, J. (1997) Cultural Variation In Health Locus Of Control. *Ethnicity & Health.* 2 (12), 13-20.
- Wyman, J.F. (1994). The Psychiatric and Emotional Impact of Female Pelvic Floor Dysfunction. *Curr Opinion in Obstet Gynecol.* 6, 336-339.
- Wyman, J.F., Harkins, S.W., Fantl, J.A. (1990). Psychosocial Impact of Urinary Incontinence in the Community-Dwelling Population. *JAGS.* 38, 282-288.
- Yip S.K., Chung T.K.H. (2003). Treatment-Seeking Behavior in Hong Kong Chinese Women with Urinary Symptoms. *Int Urogynecol J.* 14, 27-30.

Zuckerman, M., Guerra, L., Drossman, D., Foland, J., and Gregory, G. (1996). Health-Care-Seeking Behaviors Related To Bowel Complaints - Hispanics Versus Whites. *Dig Dis Sciences*. 41, 77-82..

ADDENDIX 1

Survey Questionnaire

19. Hello. My name is _____. I'm calling from the Survey Research Center at the University of Louisville. We are gathering very important information on reasons why women do not seek care for uncontrollable urine leakage. This study is sponsored by the National Institutes of Health. You have been chosen randomly to be interviewed. There are no risks or benefits to your being in this survey. However, the results of this study will be used to design interventions to increase the number of women who seek care. Taking part in this survey is up to you. You don't have to answer any questions you don't want to, and you are free to end the interview at any time. The interview takes about 20 minutes, depending on your responses. All the information you give us will be confidential to the extent permitted by law. If you have any questions about this survey, I will provide a telephone number for you to call to get more information.

SCREEN2

(CHECK ONLY ONE ANSWER)

- 1. CONTINUE (PRESS ENTER)
- 2. REFUSE (GO TO QUESTION 187)
- 3. BUSINESS or LANGUAGE BARRIER or NOT ELIGIBLE (GO TO QUESTION 187)
- 4. CALLBACK (GO TO QUESTION 188)

20. Time interview started.

INTIME

____|____|____|____|____|

21. First, I have to collect some demographic information about you. In what year were you born?

Q3

19|____|____|

IF (#21 > 68 OR #21 < 17) GO TO #179

22. Which of the following ethnic groups do you consider yourself to belong to? Are you . . .

Q4

(CHECK ONLY ONE ANSWER)

- 1. White and not Hispanic (Whites)
- 2. Black and not Hispanic (Black)
- 3. Hispanic, or
- 4. Other
- 5. (DO NOT READ) REFUSE
- 6. (DO NOT READ) NO ANSWER

23. What is your marital status?

Q4A

(CHECK ONLY ONE ANSWER)

- 1. Married
- 2. Single
- 3. Divorced
- 4. Widowed
- 5. Other

24. What education level have you completed?

Enter grade level for highest grade completed or

- 13 = one year of college
- 22 = one year trade school
- 14 = two years of college
- 15 = three years of college
- 16 = four years of college
- 17 = more than four years of college
- 0 = no schooling

Q5

25. Computing education weight

Q5A

- COMPUTE IF (#24 = 0) 28
- COMPUTE IF (#24 = 1) 30
- COMPUTE IF (#24 = 2) 30
- COMPUTE IF (#24 = 3) 32
- COMPUTE IF (#24 = 4) 32
- COMPUTE IF (#24 = 5) 34
- COMPUTE IF (#24 = 6) 34
- COMPUTE IF (#24 = 7) 36
- COMPUTE IF (#24 = 8) 41
- COMPUTE IF (#24 = 9) 24
- COMPUTE IF (#24 = 10) 46
- COMPUTE IF (#24 = 11) 48
- COMPUTE IF (#24 = 12) 53
- COMPUTE IF (#24 = 13) 60
- COMPUTE IF (#24 = 14) 61
- COMPUTE IF (#24 = 15) 63
- COMPUTE IF (#24 = 16) 66
- COMPUTE IF (#24 = 17) 73
- COMPUTE IF (#24 = 22) 56

26. What type of work (job or occupation) does the head of the household in your family perform? If retired, what type of work was done prior to retirement?

Q6

27. What type of primary medical insurance do you have?

(INTERVIEWER NOTE: It could be a HMO or PPO. It could be private insurance purchased directly from a health insurance company or insurance from an employer. It could be Medicare with or without a supplement. It could be Medicaid (Passport near Louisville) or another government sponsored policy. Or they could have no health insurance.)

Q7

28. Have you experienced uncontrollable urine leakage over the past 12 months?

Q8

(CHECK ONLY ONE ANSWER)

- 1. YES
- 2. NO
- 3. (DO NOT READ) REFUSE
- 4. (DO NOT READ) NO ANSWER

IF (#28 > 1) GO TO #180

29. Did you first notice symptoms of uncontrollable urine leakage in the past 12 months or earlier than that

Q9

(CHECK ONLY ONE ANSWER)

- 1. Past 12 months
- 2. More than a year ago (GO TO QUESTION 31)
- 3. (DO NOT READ) REFUSE
- 4. (DO NOT READ) NO ANSWER

30. How many months ago was that?

Q9A

□□□

SKIP TO QUESTION 32
=====

31. How many years ago was that?

Q9B

□□□

32. How would you best describe your uncontrollable urine leakage now as compared to when you first noticed it?

Q10

(CHECK ONLY ONE ANSWER)

- 1. better
- 2. no change
- 3. worse
- 4. (DO NOT READ) REFUSE
- 5. (DO NOT READ) NO ANSWER

33. Do you experience leakage of urine when you cough, sneeze, laugh, lift, walk or change positions?

Q11

(CHECK ONLY ONE ANSWER)

- 1. YES
- 2. NO
- 3. (DO NOT READ) REFUSE
- 4. (DO NOT READ) NO ANSWER

34. Do you experience leakage of urine associated with a strong and sudden urge to urinate before reaching the toilet?

Q12

(CHECK ONLY ONE ANSWER)

- 1. YES
- 2. NO
- 3. (DO NOT READ) REFUSE
- 4. (DO NOT READ) NO ANSWER

35. On average, how often do you experience urine leakage?

Q13

(CHECK ONLY ONE ANSWER)

- 1. less than once a month
- 2. a few times a month
- 3. a few times a week
- 4. every day or night
- 5. (DO NOT READ) REFUSE
- 6. (DO NOT READ) NO ANSWER

36. On average, how much urine do you lose each time?

Q14

(CHECK ONLY ONE ANSWER)

- 1. drops
- 2. small splashes
- 3. more
- 4. (DO NOT READ) REFUSE
- 5. (DO NOT READ) NO ANSWER

37. On average, how many pads do you wear in a day to protect your clothes from your uncontrollable urine leakage?

Q15

pads per day

38. Have you sought care from a healthcare practitioner for uncontrollable urine leakage in the past 12 months?

INTERVIEWER NOTE: "Health care practitioner" refers to physician or nurse practitioner.

Q16

(CHECK ONLY ONE ANSWER)

- 1. YES
- 2. NO
- 3. (DO NOT READ) REFUSE
- 4. (DO NOT READ) NO ANSWER

39. Do you have any close relatives with uncontrollable urine leakage?

Q17

(CHECK ONLY ONE ANSWER)

- 1. YES
- 2. NO
- 3. (DO NOT READ) REFUSE
- 4. (DO NOT READ) NO ANSWER

40. Do you have any close friends with uncontrollable urine leakage?

Q18

(CHECK ONLY ONE ANSWER)

- 1. YES
- 2. NO
- 3. (DO NOT READ) REFUSE
- 4. (DO NOT READ) NO ANSWER

41. In the following questions, I will be asking how uncontrollable urine leakage affects your daily life. The choices are not at all, slightly, moderately or greatly. Does your urine leakage . . .

AVOID

PRESS ENTER TO CONTINUE

42. (READ ONLY IF NECESSARY) Does your urine leakage . . .
Affect your ability to do
household chores such as cooking, housecleaning, laundry?

A1

(CHECK ONLY ONE ANSWER)

- 1. Not at all
- 2. Slightly
- 3. Moderately
- 4. Greatly
- 5. (DO NOT READ) REFUSE
- 6. (DO NOT READ) NO ANSWER

43. (READ ONLY IF NECESSARY) Does your urine leakage . . .
Your ability to do physical recreation such as walking,
swimming or other exercise?

A2

(CHECK ONLY ONE ANSWER)

- 1. Not at all
- 2. Slightly
- 3. Moderately
- 4. Greatly
- 5. (DO NOT READ) REFUSE
- 6. (DO NOT READ) NO ANSWER

44. (READ ONLY IF NECESSARY) Does your urine leakage . . .
Your participation in entertainment activities such as going
to movies, concerts, etc.?

A3

(CHECK ONLY ONE ANSWER)

- 1. Not at all
- 2. Slightly
- 3. Moderately
- 4. Greatly
- 5. (DO NOT READ) REFUSE
- 6. (DO NOT READ) NO ANSWER

45. (READ ONLY IF NECESSARY) Does your urine leakage . . .
Your ability to travel by car or bus more than 30 minutes from home?

A4

(CHECK ONLY ONE ANSWER)

- 1. Not at all
- 2. Slightly
- 3. Moderately
- 4. Greatly
- 5. (DO NOT READ) REFUSE
- 6. (DO NOT READ) NO ANSWER

46. (READ ONLY IF NECESSARY) Does your urine leakage . . .
Your participation in social activities outside the home?

A5

(CHECK ONLY ONE ANSWER)

- 1. Not at all
- 2. Slightly

- 3. Moderately
- 4. Greatly
- 5. (DO NOT READ) REFUSE
- 6. (DO NOT READ) NO ANSWER

47. (READ ONLY IF NECESSARY) Does your urine leakage . . .
Does your uncontrollable urine leakage affect your emotional health?

A6

(CHECK ONLY ONE ANSWER)

- 1. Not at all
- 2. Slightly
- 3. Moderately
- 4. Greatly
- 5. (DO NOT READ) REFUSE
- 6. (DO NOT READ) NO ANSWER

48. (READ ONLY IF NECESSARY) Does your urine leakage . . .
Your feeling frustrated?

A7

(CHECK ONLY ONE ANSWER)

- 1. Not at all
- 2. Slightly
- 3. Moderately
- 4. Greatly
- 5. (DO NOT READ) REFUSE
- 6. (DO NOT READ) NO ANSWER

49. The next questions will be asking about social support
for seeking care.

INTERVIEWER NOTE: If the subject responds "no" or
"she/he is deceased", please ask the following:
"What is your perception of his/her beliefs about
seeking care right away for uncontrollable urine leakage?"
Use the same response choices. If she responds that her
husband or physician supports whatever she wants to do,
again ask, "What is your perception of his belief about
seeking care right away for uncontrollable urine leakage?"

RVOID

PRESS ENTER TO CONTINUE

50. Have you discussed seeking care for uncontrollable
urine leakage with a female friend?

R1

(CHECK ONLY ONE ANSWER)

- 1. YES (GO TO QUESTION 51)
- 2. NO
- 3. (DO NOT READ) REFUSE
- 4. (DO NOT READ) NO ANSWER

SKIP TO QUESTION 52

51. How did she feel about you seeking care right away?

R1A

(CHECK ONLY ONE ANSWER)

- 1. not at all necessary
- 2. rarely necessary
- 3. necessary
- 4. extremely necessary
- 5. (DO NOT READ) REFUSE
- 6. (DO NOT READ) NO ANSWER

52. Have you discussed seeking care for uncontrollable urine leakage with your husband/partner?

R2

(CHECK ONLY ONE ANSWER)

- 1. YES (GO TO QUESTION 53)
- 2. NO
- 3. (DO NOT READ) REFUSE
- 4. (DO NOT READ) NO ANSWER

SKIP TO QUESTION 54

53. How did he feel about you seeking care right away?

R2A

(CHECK ONLY ONE ANSWER)

- 1. not at all necessary
- 2. rarely necessary
- 3. necessary
- 4. extremely necessary
- 5. (DO NOT READ) REFUSE
- 6. (DO NOT READ) NO ANSWER

54. Have you discussed seeking care for uncontrollable urine leakage with your mother?

R3

(CHECK ONLY ONE ANSWER)

- 1. YES (GO TO QUESTION 55)
- 2. NO
- 3. (DO NOT READ) REFUSE
- 4. (DO NOT READ) NO ANSWER

SKIP TO QUESTION 56

55. How did she feel about you seeking care right away?

R3A

(CHECK ONLY ONE ANSWER)

- 1. not at all necessary
- 2. rarely necessary
- 3. necessary
- 4. extremely necessary
- 5. (DO NOT READ) REFUSE
- 6. (DO NOT READ) NO ANSWER

56. Have you discussed seeking care for uncontrollable urine leakage with another female relative?

R4

(CHECK ONLY ONE ANSWER)

- 1. YES (GO TO QUESTION 57)
- 2. NO
- 3. (DO NOT READ) REFUSE
- 4. (DO NOT READ) NO ANSWER

SKIP TO QUESTION 58

57. How did she feel about you seeking care right away?

R4A

(CHECK ONLY ONE ANSWER)

- 1. not at all necessary
- 2. rarely necessary
- 3. necessary
- 4. extremely necessary
- 5. (DO NOT READ) REFUSE
- 6. (DO NOT READ) NO ANSWER

58. Have you discussed seeking care for uncontrollable urine leakage with your usual health care practitioner?

R5

(CHECK ONLY ONE ANSWER)

- 1. YES (GO TO QUESTION 59)
- 2. NO
- 3. (DO NOT READ) REFUSE
- 4. (DO NOT READ) NO ANSWER

SKIP TO QUESTION 60

59. How did that person feel about you seeking care right away?

R5A

(CHECK ONLY ONE ANSWER)

- 1. not at all necessary
- 2. rarely necessary
- 3. necessary
- 4. extremely necessary
- 5. (DO NOT READ) REFUSE
- 6. (DO NOT READ) NO ANSWER

60. The next questions ask you to describe different feelings and emotions. Please respond by answering not at all, a little, moderately, quite a bit, or extremely.

 INTERVIEWER NOTE: The responses are based on how she generally feels, not specifically related to her uncontrollable urinary leakage.

SVOID

PRESS ENTER TO CONTINUE

61. Randomize

SRANDOM

(CHECK ONLY ONE ANSWER)

- 1. SKIP TO S1 (GO TO QUESTION 62)
- 2. SKIP TO S2 (GO TO QUESTION 63)
- 3. SKIP TO S3 (GO TO QUESTION 64)
- 4. SKIP TO S4 (GO TO QUESTION 65)
- 5. SKIP TO S5 (GO TO QUESTION 66)
- 6. SKIP TO S6 (GO TO QUESTION 67)
- 7. SKIP TO S7 (GO TO QUESTION 68)
- 8. SKIP TO S8 (GO TO QUESTION 69)
- 9. SKIP TO S9 (GO TO QUESTION 70)
- 10. SKIP TO S10 (GO TO QUESTION 71)
- 11. SKIP TO S11 (GO TO QUESTION 72)
- 12. SKIP TO S12 (GO TO QUESTION 73)
- 13. SKIP TO S13 (GO TO QUESTION 74)
- 14. SKIP TO S14 (GO TO QUESTION 75)
- 15. SKIP TO S15 (GO TO QUESTION 76)
- 16. SKIP TO S16 (GO TO QUESTION 77)
- 17. SKIP TO S17 (GO TO QUESTION 78)
- 18. SKIP TO S18 (GO TO QUESTION 79)
- 19. SKIP TO S19 (GO TO QUESTION 80)
- 20. SKIP TO S20 (GO TO QUESTION 81)

SKIP TO QUESTION 82

=====

62. (READ IF NECESSARY) To what extent do you generally feel . . .
 "Enthusiastic"?

S1

(CHECK ONLY ONE ANSWER)

- 1. Not at all
- 2. A little

- 3. Moderately
- 4. Quite a bit
- 5. Extremely
- 6. (DO NOT READ) REFUSE
- 7. (DO NOT READ) NO ANSWER

IF (#61 = 2) GO TO #82

63. (READ IF NECESSARY) To what extent do you generally feel . . .
"Distressed"?

S2

(CHECK ONLY ONE ANSWER)

- 1. Not at all
- 2. A little
- 3. Moderately
- 4. Quite a bit
- 5. Extremely
- 6. (DO NOT READ) REFUSE
- 7. (DO NOT READ) NO ANSWER

IF (#61 = 3) GO TO #82

64. (READ IF NECESSARY) To what extent do you generally feel . . .
"Excited"?

S3

(CHECK ONLY ONE ANSWER)

- 1. Not at all
- 2. A little
- 3. Moderately
- 4. Quite a bit
- 5. Extremely
- 6. (DO NOT READ) REFUSE
- 7. (DO NOT READ) NO ANSWER

IF (#61 = 4) GO TO #82

65. (READ IF NECESSARY) To what extent do you generally feel . . .
"Upset"?

S4

(CHECK ONLY ONE ANSWER)

- 1. Not at all
- 2. A little
- 3. Moderately
- 4. Quite a bit
- 5. Extremely
- 6. (DO NOT READ) REFUSE
- 7. (DO NOT READ) NO ANSWER

IF (#61 = 5) GO TO #82

66. (READ IF NECESSARY) To what extent do you generally feel . . .
"Strong"?

S5

(CHECK ONLY ONE ANSWER)

- 1. Not at all
- 2. A little
- 3. Moderately
- 4. Quite a bit
- 5. Extremely
- 6. (DO NOT READ) REFUSE
- 7. (DO NOT READ) NO ANSWER

IF (#61 = 6) GO TO #82

67. (READ IF NECESSARY) To what extent do you generally feel . . .
"Guilty"?

S6

(CHECK ONLY ONE ANSWER)

- 1. Not at all
- 2. A little
- 3. Moderately
- 4. Quite a bit
- 5. Extremely
- 6. (DO NOT READ) REFUSE
- 7. (DO NOT READ) NO ANSWER

IF (#61 = 7) GO TO #82

68. (READ IF NECESSARY) To what extent do you generally feel . . .
"Scared"?

S7

(CHECK ONLY ONE ANSWER)

- 1. Not at all
- 2. A little
- 3. Moderately
- 4. Quite a bit
- 5. Extremely
- 6. (DO NOT READ) REFUSE
- 7. (DO NOT READ) NO ANSWER

IF (#61 = 8) GO TO #82

69. (READ IF NECESSARY) To what extent do you generally feel . . .
"Hostile"?

S8

(CHECK ONLY ONE ANSWER)

- 1. Not at all
- 2. A little

- 3. Moderately
- 4. Quite a bit
- 5. Extremely
- 6. (DO NOT READ) REFUSE
- 7. (DO NOT READ) NO ANSWER

IF (#61 = 9) GO TO #82

70. (READ IF NECESSARY) To what extent do you generally feel . . .
"Interested"?

S9

(CHECK ONLY ONE ANSWER)

- 1. Not at all
- 2. A little
- 3. Moderately
- 4. Quite a bit
- 5. Extremely
- 6. (DO NOT READ) REFUSE
- 7. (DO NOT READ) NO ANSWER

IF (#61 = 10) GO TO #82

71. (READ IF NECESSARY) To what extent do you generally feel . . .
"Proud"?

S10

(CHECK ONLY ONE ANSWER)

- 1. Not at all
- 2. A little
- 3. Moderately
- 4. Quite a bit
- 5. Extremely
- 6. (DO NOT READ) REFUSE
- 7. (DO NOT READ) NO ANSWER

IF (#61 = 11) GO TO #82

72. (READ IF NECESSARY) To what extent do you generally feel . . .
"Irritable"?

S11

(CHECK ONLY ONE ANSWER)

- 1. Not at all
- 2. A little
- 3. Moderately
- 4. Quite a bit
- 5. Extremely
- 6. (DO NOT READ) REFUSE
- 7. (DO NOT READ) NO ANSWER

IF (#61 = 12) GO TO #82

73. (READ IF NECESSARY) To what extent do you generally feel . . .
"Alert"?

S12

(CHECK ONLY ONE ANSWER)

- 1. Not at all
- 2. A little
- 3. Moderately
- 4. Quite a bit
- 5. Extremely
- 6. (DO NOT READ) REFUSE
- 7. (DO NOT READ) NO ANSWER

IF (#61 = 13) GO TO #82

74. (READ IF NECESSARY) To what extent do you generally feel . . .
"Ashamed"?

S13

(CHECK ONLY ONE ANSWER)

- 1. Not at all
- 2. A little
- 3. Moderately
- 4. Quite a bit
- 5. Extremely
- 6. (DO NOT READ) REFUSE
- 7. (DO NOT READ) NO ANSWER

IF (#61 = 14) GO TO #82

75. (READ IF NECESSARY) To what extent do you generally feel . . .
"Inspired"?

S14

(CHECK ONLY ONE ANSWER)

- 1. Not at all
- 2. A little
- 3. Moderately
- 4. Quite a bit
- 5. Extremely
- 6. (DO NOT READ) REFUSE
- 7. (DO NOT READ) NO ANSWER

IF (#61 = 15) GO TO #82

76. (READ IF NECESSARY) To what extent do you generally feel . . .
"Nervous"?

S15

(CHECK ONLY ONE ANSWER)

- 1. Not at all
- 2. A little

- 3. Moderately
- 4. Quite a bit
- 5. Extremely
- 6. (DO NOT READ) REFUSE
- 7. (DO NOT READ) NO ANSWER

IF (#61 = 16) GO TO #82

77. (READ IF NECESSARY) To what extent do you generally feel . . .
"Determined"?

S16

(CHECK ONLY ONE ANSWER)

- 1. Not at all
- 2. A little
- 3. Moderately
- 4. Quite a bit
- 5. Extremely
- 6. (DO NOT READ) REFUSE
- 7. (DO NOT READ) NO ANSWER

IF (#61 = 17) GO TO #82

78. (READ IF NECESSARY) To what extent do you generally feel . . .
"Attentive"?

S17

(CHECK ONLY ONE ANSWER)

- 1. Not at all
- 2. A little
- 3. Moderately
- 4. Quite a bit
- 5. Extremely
- 6. (DO NOT READ) REFUSE
- 7. (DO NOT READ) NO ANSWER

IF (#61 = 18) GO TO #82

79. (READ IF NECESSARY) To what extent do you generally feel . . .
"Jittery"?

S18

(CHECK ONLY ONE ANSWER)

- 1. Not at all
- 2. A little
- 3. Moderately
- 4. Quite a bit
- 5. Extremely
- 6. (DO NOT READ) REFUSE
- 7. (DO NOT READ) NO ANSWER

IF (#61 = 19) GO TO #82

80. (READ IF NECESSARY) To what extent do you generally feel . . .
"Active"?

S19

(CHECK ONLY ONE ANSWER)

- 1. Not at all
- 2. A little
- 3. Moderately
- 4. Quite a bit
- 5. Extremely
- 6. (DO NOT READ) REFUSE
- 7. (DO NOT READ) NO ANSWER

IF (#61 = 20) GO TO #82

81. (READ IF NECESSARY) To what extent do you generally feel . . .
"Afraid"?

S20

(CHECK ONLY ONE ANSWER)

- 1. Not at all
- 2. A little
- 3. Moderately
- 4. Quite a bit
- 5. Extremely
- 6. (DO NOT READ) REFUSE
- 7. (DO NOT READ) NO ANSWER

IF (#61 = 1) GO TO #82

SKIP TO QUESTION 62

82. In the following questions, I will ask about your health habits. The response choices are: not important, somewhat important, important, or extremely important. How important is it for you to engage or practice in preventative health care behaviors such as:

TVOID

PRESS ENTER TO CONTINUE

83. READ IF NECESSARY: How important is it for you to engage in or practice preventive health care behaviors such as . . .
Having a regular exercise program

T1

(CHECK ONLY ONE ANSWER)

- 1. not important,
- 2. somewhat important,
- 3. important, or
- 4. extremely important.
- 5. (DO NOT READ) REFUSE

6. (DO NOT READ) NO ANSWER

84. READ IF NECESSARY: How important is it for you to engage in or practice preventive health care behaviors such as . . .

Following a low fat, low salt diet

T2

(CHECK ONLY ONE ANSWER)

- 1. not important,
- 2. somewhat important,
- 3. important, or
- 4. extremely important.
- 5. (DO NOT READ) REFUSE
- 6. (DO NOT READ) NO ANSWER

85. READ IF NECESSARY: How important is it for you to engage in or practice preventive health care behaviors such as . . .

Having a smoke detector in the house

T3

(CHECK ONLY ONE ANSWER)

- 1. not important,
- 2. somewhat important,
- 3. important, or
- 4. extremely important.
- 5. (DO NOT READ) REFUSE
- 6. (DO NOT READ) NO ANSWER

86. READ IF NECESSARY: How important is it for you to engage in or practice preventive health care behaviors such as . . .

Watching your weight

T4

(CHECK ONLY ONE ANSWER)

- 1. not important,
- 2. somewhat important,
- 3. important, or
- 4. extremely important.
- 5. (DO NOT READ) REFUSE
- 6. (DO NOT READ) NO ANSWER

87. On average, how often do you see a physician for a physical exam?

U1

(CHECK ONLY ONE ANSWER)

- 1. more than 3 years since last visit (includes "never")
- 2. every 2-3 years
- 3. annually
- 4. once a month
- 5. (DO NOT READ) REFUSE
- 6. (DO NOT READ) NO ANSWER

88. How do you usually act when faced with a health related problem or symptom?

U2

(CHECK ONLY ONE ANSWER)

- 1. do not seek care
- 2. wait to see if health problems/symptoms persist & then seek care
- 3. seek care right away
- 4. (DO NOT READ) REFUSE
- 5. (DO NOT READ) NO ANSWER

89. How do you usually act when faced with a urinary tract infection?

U3

(CHECK ONLY ONE ANSWER)

- 1. do not seek care
- 2. wait to see if urinary tract symptoms persist & then seek care
- 3. seek care right away
- 4. (DO NOT READ) REFUSE
- 5. (DO NOT READ) NO ANSWER

90. How do you usually act when faced with depression?

U4

(CHECK ONLY ONE ANSWER)

- 1. do not seek care
- 2. wait to see if symptoms of depression persist & then seek care
- 3. seek care right away
- 4. (DO NOT READ) REFUSE
- 5. (DO NOT READ) NO ANSWER

91. Is uncontrollable urine leakage a medical problem?

U5

(CHECK ONLY ONE ANSWER)

- 1. YES
- 2. NO
- 3. (DO NOT READ) REFUSE
- 4. (DO NOT READ) NO ANSWER

92. In the following questions, I will ask about your expectations when seeking care for uncontrollable urine leakage.

What do you think is likely to happen if you seek care.

On a scale of 0 to 10 where 0 represents "not at all likely" and 10 represents "definitely likely". Answer choices 5 and 6 do not represent "I don't know". Remember, I'd like you to consider when seeking care.

INTERVIEWER NOTE: Responses are based on her expectations when seeking care, not her actual experience when seeking care.

VVOID

PRESS ENTER TO CONTINUE

93. Randomize

VRANDOM

(CHECK ONLY ONE ANSWER)

- 1. SKIP TO V1 (GO TO QUESTION 94)
- 2. SKIP TO V2 (GO TO QUESTION 95)
- 3. SKIP TO V3 (GO TO QUESTION 96)
- 4. SKIP TO V4 (GO TO QUESTION 97)
- 5. SKIP TO V5 (GO TO QUESTION 98)
- 6. SKIP TO V6 (GO TO QUESTION 99)
- 7. SKIP TO V7 (GO TO QUESTION 100)
- 8. SKIP TO V8 (GO TO QUESTION 101)
- 9. SKIP TO V9 (GO TO QUESTION 102)
- 10. SKIP TO V10 (GO TO QUESTION 103)
- 11. SKIP TO V11 (GO TO QUESTION 104)
- 12. SKIP TO V12 (GO TO QUESTION 105)
- 13. SKIP TO V13 (GO TO QUESTION 106)
- 14. SKIP TO V14 (GO TO QUESTION 107)
- 15. SKIP TO V15 (GO TO QUESTION 108)
- 16. SKIP TO V16 (GO TO QUESTION 109)
- 17. SKIP TO V17 (GO TO QUESTION 110)
- 18. SKIP TO V18 (GO TO QUESTION 111)
- 19. SKIP TO V19 (GO TO QUESTION 112)
- 20. SKIP TO V20 (GO TO QUESTION 113)
- 21. SKIP TO V21 (GO TO QUESTION 114)

SKIP TO QUESTION 115

94. (READ AS OFTEN AS NEEDED: WHEN SEEKING CARE FOR UNCONTROLLABLE URINE LEAKAGE, HOW LIKELY WOULD IT BE THAT THIS WOULD HAPPEN?)

"I would be told it was a normal part of aging."

V1

(CHECK ONLY ONE ANSWER)

- 1. 0 = NOT AT ALL LIKELY
- 2. 1
- 3. 2
- 4. 3
- 5. 4
- 6. 5
- 7. 6
- 8. 7
- 9. 8
- 10. 9
- 11. 10 = DEFINITELY LIKELY
- 12. (DO NOT READ) REFUSE
- 13. (DO NOT READ) DON'T KNOW/NO ANSWER

IF (#93 = 2) GO TO #115

95. (READ AS OFTEN AS NEEDED: WHEN SEEKING CARE FOR UNCONTROLLABLE URINE LEAKAGE, HOW LIKELY WOULD IT BE THAT THIS WOULD HAPPEN?)

"I would regain control of my life."

V2

(CHECK ONLY ONE ANSWER)

- 1. 0 = NOT AT ALL LIKELY
- 2. 1
- 3. 2
- 4. 3
- 5. 4
- 6. 5
- 7. 6
- 8. 7
- 9. 8
- 10. 9
- 11. 10 = DEFINITELY LIKELY
- 12. (DO NOT READ) REFUSE
- 13. (DO NOT READ) DON'T KNOW/NO ANSWER

IF (#93 = 3) GO TO #115

96. (READ AS OFTEN AS NEEDED: WHEN SEEKING CARE FOR UNCONTROLLABLE URINE LEAKAGE, HOW LIKELY WOULD IT BE THAT THIS WOULD HAPPEN?)

"I would be labeled a hypochondriac."

V3

(CHECK ONLY ONE ANSWER)

- 1. 0 = NOT AT ALL LIKELY
- 2. 1
- 3. 2
- 4. 3
- 5. 4
- 6. 5
- 7. 6
- 8. 7
- 9. 8
- 10. 9
- 11. 10 = DEFINITELY LIKELY
- 12. (DO NOT READ) REFUSE
- 13. (DO NOT READ) DON'T KNOW/NO ANSWER

IF (#93 = 4) GO TO #115

97. (READ AS OFTEN AS NEEDED: WHEN SEEKING CARE FOR UNCONTROLLABLE URINE LEAKAGE, HOW LIKELY WOULD IT BE THAT THIS WOULD HAPPEN?)

"I would be embarrassed."

V4

(CHECK ONLY ONE ANSWER)

- 1. 0 = NOT AT ALL LIKELY
- 2. 1
- 3. 2
- 4. 3
- 5. 4
- 6. 5

- 7. 6
- 8. 7
- 9. 8
- 10. 9
- 11. 10 = DEFINITELY LIKELY
- 12. (DO NOT READ) REFUSE
- 13. (DO NOT READ) DON'T KNOW/NO ANSWER

IF (#93 = 5) GO TO #115

98. (READ AS OFTEN AS NEEDED: WHEN SEEKING CARE FOR UNCONTROLLABLE URINE LEAKAGE, HOW LIKELY WOULD IT BE THAT THIS WOULD HAPPEN?)
 "I would use fewer pads."

V5

(CHECK ONLY ONE ANSWER)

- 1. 0 = NOT AT ALL LIKELY
- 2. 1
- 3. 2
- 4. 3
- 5. 4
- 6. 5
- 7. 6
- 8. 7
- 9. 8
- 10. 9
- 11. 10 = DEFINITELY LIKELY
- 12. (DO NOT READ) REFUSE
- 13. (DO NOT READ) DON'T KNOW/NO ANSWER

IF (#93 = 6) GO TO #115

99. (READ AS OFTEN AS NEEDED: WHEN SEEKING CARE FOR UNCONTROLLABLE URINE LEAKAGE, HOW LIKELY WOULD IT BE THAT THIS WOULD HAPPEN?)
 "My doctor would tell me I need medication."

V6

(CHECK ONLY ONE ANSWER)

- 1. 0 = NOT AT ALL LIKELY
- 2. 1
- 3. 2
- 4. 3
- 5. 4
- 6. 5
- 7. 6
- 8. 7
- 9. 8
- 10. 9
- 11. 10 = DEFINITELY LIKELY
- 12. (DO NOT READ) REFUSE
- 13. (DO NOT READ) DON'T KNOW/NO ANSWER

IF (#93 = 7) GO TO #115

100. (READ AS OFTEN AS NEEDED: WHEN SEEKING CARE FOR UNCONTROLLABLE URINE LEAKAGE, HOW LIKELY WOULD IT BE THAT THIS WOULD HAPPEN?)

"I would feel better about myself."

V7

(CHECK ONLY ONE ANSWER)

- 1. 0 = NOT AT ALL LIKELY
- 2. 1
- 3. 2
- 4. 3
- 5. 4
- 6. 5
- 7. 6
- 8. 7
- 9. 8
- 10. 9
- 11. 10 = DEFINITELY LIKELY
- 12. (DO NOT READ) REFUSE
- 13. (DO NOT READ) DON'T KNOW/NO ANSWER

IF (#93 = 8) GO TO #115

101. (READ AS OFTEN AS NEEDED: WHEN SEEKING CARE FOR UNCONTROLLABLE URINE LEAKAGE, HOW LIKELY WOULD IT BE THAT THIS WOULD HAPPEN?)

"I would be able to resume my normal activities."

V8

(CHECK ONLY ONE ANSWER)

- 1. 0 = NOT AT ALL LIKELY
- 2. 1
- 3. 2
- 4. 3
- 5. 4
- 6. 5
- 7. 6
- 8. 7
- 9. 8
- 10. 9
- 11. 10 = DEFINITELY LIKELY
- 12. (DO NOT READ) REFUSE
- 13. (DO NOT READ) DON'T KNOW/NO ANSWER

IF (#93 = 9) GO TO #115

102. (READ AS OFTEN AS NEEDED: WHEN SEEKING CARE FOR UNCONTROLLABLE URINE LEAKAGE, HOW LIKELY WOULD IT BE THAT THIS WOULD HAPPEN?)

"I would be told to do Kegel exercises."

V9

(CHECK ONLY ONE ANSWER)

- 1. 0 = NOT AT ALL LIKELY
- 2. 1
- 3. 2

- 4.3
- 5.4
- 6.5
- 7.6
- 8.7
- 9.8
- 10.9
- 11. 10 = DEFINITELY LIKELY
- 12. (DO NOT READ) REFUSE
- 13. (DO NOT READ) DON'T KNOW/NO ANSWER

IF (#93 = 10) GO TO #115

103. (READ AS OFTEN AS NEEDED: WHEN SEEKING CARE FOR UNCONTROLLABLE URINE LEAKAGE, HOW LIKELY WOULD IT BE THAT THIS WOULD HAPPEN?)
 "My doctor would tell me it is normal after having children."

V10

(CHECK ONLY ONE ANSWER)

- 1. 0 = NOT AT ALL LIKELY
- 2. 1
- 3. 2
- 4. 3
- 5. 4
- 6. 5
- 7. 6
- 8. 7
- 9. 8
- 10. 9
- 11. 10 = DEFINITELY LIKELY
- 12. (DO NOT READ) REFUSE
- 13. (DO NOT READ) DON'T KNOW/NO ANSWER

IF (#93 = 11) GO TO #115

104. (READ AS OFTEN AS NEEDED: WHEN SEEKING CARE FOR UNCONTROLLABLE URINE LEAKAGE, HOW LIKELY WOULD IT BE THAT THIS WOULD HAPPEN?)
 "I would find out it was a common medical condition."

V11

(CHECK ONLY ONE ANSWER)

- 1. 0 = NOT AT ALL LIKELY
- 2. 1
- 3. 2
- 4. 3
- 5. 4
- 6. 5
- 7. 6
- 8. 7
- 9. 8
- 10. 9
- 11. 10 = DEFINITELY LIKELY
- 12. (DO NOT READ) REFUSE
- 13. (DO NOT READ) DON'T KNOW/NO ANSWER

IF (#93 = 12) GO TO #115

105. (READ AS OFTEN AS NEEDED: WHEN SEEKING CARE FOR UNCONTROLLABLE URINE LEAKAGE, HOW LIKELY WOULD IT BE THAT THIS WOULD HAPPEN?)

"I would regain control of my bladder."

V12

(CHECK ONLY ONE ANSWER)

- 1. 0 = NOT AT ALL LIKELY
- 2. 1
- 3. 2
- 4. 3
- 5. 4
- 6. 5
- 7. 6
- 8. 7
- 9. 8
- 10. 9
- 11. 10 = DEFINITELY LIKELY
- 12. (DO NOT READ) REFUSE
- 13. (DO NOT READ) DON'T KNOW/NO ANSWER

IF (#93 = 13) GO TO #115

106. (READ AS OFTEN AS NEEDED: WHEN SEEKING CARE FOR UNCONTROLLABLE URINE LEAKAGE, HOW LIKELY WOULD IT BE THAT THIS WOULD HAPPEN?)

"I would get information about my diagnosis and treatment options."

V13

(CHECK ONLY ONE ANSWER)

- 1. 0 = NOT AT ALL LIKELY
- 2. 1
- 3. 2
- 4. 3
- 5. 4
- 6. 5
- 7. 6
- 8. 7
- 9. 8
- 10. 9
- 11. 10 = DEFINITELY LIKELY
- 12. (DO NOT READ) REFUSE
- 13. (DO NOT READ) DON'T KNOW/NO ANSWER

IF (#93 = 14) GO TO #115

107. (READ AS OFTEN AS NEEDED: WHEN SEEKING CARE FOR UNCONTROLLABLE URINE LEAKAGE, HOW LIKELY WOULD IT BE THAT THIS WOULD HAPPEN?)

"I would find out if my symptoms were from a serious illness like cancer."

V14

(CHECK ONLY ONE ANSWER)

- 1. 0 = NOT AT ALL LIKELY
- 2. 1
- 3. 2
- 4. 3
- 5. 4
- 6. 5
- 7. 6
- 8. 7
- 9. 8
- 10. 9
- 11. 10 = DEFINITELY LIKELY
- 12. (DO NOT READ) REFUSE
- 13. (DO NOT READ) DON'T KNOW/NO ANSWER

IF (#93 = 15) GO TO #115

108. (READ AS OFTEN AS NEEDED: WHEN SEEKING CARE FOR UNCONTROLLABLE URINE LEAKAGE, HOW LIKELY WOULD IT BE THAT THIS WOULD HAPPEN?)

"I would be told to lose weight."

V15

(CHECK ONLY ONE ANSWER)

- 1. 0 = NOT AT ALL LIKELY
- 2. 1
- 3. 2
- 4. 3
- 5. 4
- 6. 5
- 7. 6
- 8. 7
- 9. 8
- 10. 9
- 11. 10 = DEFINITELY LIKELY
- 12. (DO NOT READ) REFUSE
- 13. (DO NOT READ) DON'T KNOW/NO ANSWER

IF (#93 = 16) GO TO #115

109. (READ AS OFTEN AS NEEDED: WHEN SEEKING CARE FOR UNCONTROLLABLE URINE LEAKAGE, HOW LIKELY WOULD IT BE THAT THIS WOULD HAPPEN?)

"I would be referred to a specialist."

V16

(CHECK ONLY ONE ANSWER)

- 1. 0 = NOT AT ALL LIKELY
- 2. 1
- 3. 2
- 4. 3
- 5. 4
- 6. 5
- 7. 6
- 8. 7

- 9. 8
- 10. 9
- 11. 10 = DEFINITELY LIKELY
- 12. (DO NOT READ) REFUSE
- 13. (DO NOT READ) DON'T KNOW/NO ANSWER

IF (#93 = 17) GO TO #115

110. (READ AS OFTEN AS NEEDED: WHEN SEEKING CARE FOR UNCONTROLLABLE URINE LEAKAGE, HOW LIKELY WOULD IT BE THAT THIS WOULD HAPPEN?)

"My quality of life would improve."

V17

(CHECK ONLY ONE ANSWER)

- 1. 0 = NOT AT ALL LIKELY
- 2. 1
- 3. 2
- 4. 3
- 5. 4
- 6. 5
- 7. 6
- 8. 7
- 9. 8
- 10. 9
- 11. 10 = DEFINITELY LIKELY
- 12. (DO NOT READ) REFUSE
- 13. (DO NOT READ) DON'T KNOW/NO ANSWER

IF (#93 = 18) GO TO #115

111. (READ AS OFTEN AS NEEDED: WHEN SEEKING CARE FOR UNCONTROLLABLE URINE LEAKAGE, HOW LIKELY WOULD IT BE THAT THIS WOULD HAPPEN?)

"I would be told that there is nothing that can be done."

V18

(CHECK ONLY ONE ANSWER)

- 1. 0 = NOT AT ALL LIKELY
- 2. 1
- 3. 2
- 4. 3
- 5. 4
- 6. 5
- 7. 6
- 8. 7
- 9. 8
- 10. 9
- 11. 10 = DEFINITELY LIKELY
- 12. (DO NOT READ) REFUSE
- 13. (DO NOT READ) DON'T KNOW/NO ANSWER

IF (#93 = 19) GO TO #115

112. (READ AS OFTEN AS NEEDED: WHEN SEEKING CARE FOR UNCONTROLLABLE

URINE LEAKAGE, HOW LIKELY WOULD IT BE THAT THIS WOULD HAPPEN?)

"I would resume normal social relationships."

V19

(CHECK ONLY ONE ANSWER)

- 1. 0 = NOT AT ALL LIKELY
- 2. 1
- 3. 2
- 4. 3
- 5. 4
- 6. 5
- 7. 6
- 8. 7
- 9. 8
- 10. 9
- 11. 10 = DEFINITELY LIKELY
- 12. (DO NOT READ) REFUSE
- 13. (DO NOT READ) DON'T KNOW/NO ANSWER

IF (#93 = 20) GO TO #115

113. (READ AS OFTEN AS NEEDED: WHEN SEEKING CARE FOR UNCONTROLLABLE URINE LEAKAGE, HOW LIKELY WOULD IT BE THAT THIS WOULD HAPPEN?)

"My doctor would tell me I need surgery."

V20

(CHECK ONLY ONE ANSWER)

- 1. 0 = NOT AT ALL LIKELY
- 2. 1
- 3. 2
- 4. 3
- 5. 4
- 6. 5
- 7. 6
- 8. 7
- 9. 8
- 10. 9
- 11. 10 = DEFINITELY LIKELY
- 12. (DO NOT READ) REFUSE
- 13. (DO NOT READ) DON'T KNOW/NO ANSWER

IF (#93 = 21) GO TO #115

114. (READ AS OFTEN AS NEEDED: WHEN SEEKING CARE FOR UNCONTROLLABLE URINE LEAKAGE, HOW LIKELY WOULD IT BE THAT THIS WOULD HAPPEN?)

"I would be told it was caused by something I had done in my past."

V21

(CHECK ONLY ONE ANSWER)

- 1. 0 = NOT AT ALL LIKELY
- 2. 1
- 3. 2
- 4. 3
- 5. 4

- 6. 5
- 7. 6
- 8. 7
- 9. 8
- 10. 9
- 11. 10 = DEFINITELY LIKELY
- 12. (DO NOT READ) REFUSE
- 13. (DO NOT READ) DON'T KNOW/NO ANSWER

IF (#93 = 1) GO TO #115

SKIP TO QUESTION 94

115. In the following section, the statements are the same but I would like you to think about them in a different way.

How much of a difference would the following statements make when deciding to seek care using a scale of 0 to 10 where 0 represents "no difference" and 10 represents "huge difference"?

(INTERVIEWER NOTE: If she pauses after a statement, you may clarify by asking, "How much of a difference would that make in your decision to seek care?" This may be done after each statement, if necessary. Or you might ask, "Would that make a difference in your decision? How much of a difference, on a scale of 0 to 10?")

WVOID

PRESS ENTER TO CONTINUE

116. Randomize

WRANDOM

(CHECK ONLY ONE ANSWER)

- 1. SKIP TO W1 (GO TO QUESTION 117)
- 2. SKIP TO W2 (GO TO QUESTION 118)
- 3. SKIP TO W3 (GO TO QUESTION 119)
- 4. SKIP TO W4 (GO TO QUESTION 120)
- 5. SKIP TO W5 (GO TO QUESTION 121)
- 6. SKIP TO W6 (GO TO QUESTION 122)
- 7. SKIP TO W7 (GO TO QUESTION 123)
- 8. SKIP TO W8 (GO TO QUESTION 124)
- 9. SKIP TO W9 (GO TO QUESTION 125)
- 10. SKIP TO W10 (GO TO QUESTION 126)
- 11. SKIP TO W11 (GO TO QUESTION 127)
- 12. SKIP TO W12 (GO TO QUESTION 128)
- 13. SKIP TO W13 (GO TO QUESTION 129)
- 14. SKIP TO W14 (GO TO QUESTION 130)
- 15. SKIP TO W15 (GO TO QUESTION 131)
- 16. SKIP TO W16 (GO TO QUESTION 132)
- 17. SKIP TO W17 (GO TO QUESTION 133)
- 18. SKIP TO W18 (GO TO QUESTION 134)
- 19. SKIP TO W19 (GO TO QUESTION 135)
- 20. SKIP TO W20 (GO TO QUESTION 136)
- 21. SKIP TO W21 (GO TO QUESTION 137)

SKIP TO QUESTION 138

117. "I would be told it was a normal part of aging."
(READ AS OFTEN AS NEEDED: "HOW MUCH OF A DIFFERENCE
WOULD THAT MAKE IN YOUR DECISION TO SEEK CARE.)

W1

(CHECK ONLY ONE ANSWER)

- 1. 0 = NO DIFFERENCE
- 2. 1
- 3. 2
- 4. 3
- 5. 4
- 6. 5
- 7. 6
- 8. 7
- 9. 8
- 10. 9
- 11. 10 = HUGE DIFFERENCE
- 12. (DO NOT READ) REFUSE
- 13. (DO NOT READ) DON'T KNOW/NO ANSWER

IF (#116 = 2) GO TO #138

118. "I would regain control of my life."
(READ AS OFTEN AS NEEDED: "HOW MUCH OF A DIFFERENCE
WOULD THAT MAKE IN YOUR DECISION TO SEEK CARE.)

W2

(CHECK ONLY ONE ANSWER)

- 1. 0 = NO DIFFERENCE
- 2. 1
- 3. 2
- 4. 3
- 5. 4
- 6. 5
- 7. 6
- 8. 7
- 9. 8
- 10. 9
- 11. 10 = HUGE DIFFERENCE
- 12. (DO NOT READ) REFUSE
- 13. (DO NOT READ) DON'T KNOW/NO ANSWER

IF (#116 = 3) GO TO #138

119. "I would be labeled a hypochondriac."
(READ AS OFTEN AS NEEDED: "HOW MUCH OF A DIFFERENCE
WOULD THAT MAKE IN YOUR DECISION TO SEEK CARE.)

W3

(CHECK ONLY ONE ANSWER)

- 1. 0 = NO DIFFERENCE
- 2. 1
- 3. 2
- 4. 3
- 5. 4
- 6. 5
- 7. 6
- 8. 7
- 9. 8
- 10. 9
- 11. 10 = HUGE DIFFERENCE
- 12. (DO NOT READ) REFUSE
- 13. (DO NOT READ) DON'T KNOW/NO ANSWER

IF (#116 = 4) GO TO #138

120. "I would be embarrassed."

(READ AS OFTEN AS NEEDED: "HOW MUCH OF A DIFFERENCE WOULD THAT MAKE IN YOUR DECISION TO SEEK CARE.)

W4

(CHECK ONLY ONE ANSWER)

- 1. 0 = NO DIFFERENCE
- 2. 1
- 3. 2
- 4. 3
- 5. 4
- 6. 5
- 7. 6
- 8. 7
- 9. 8
- 10. 9
- 11. 10 = HUGE DIFFERENCE
- 12. (DO NOT READ) REFUSE
- 13. (DO NOT READ) DON'T KNOW/NO ANSWER

IF (#116 = 5) GO TO #138

121. "I would use fewer pads."

(READ AS OFTEN AS NEEDED: "HOW MUCH OF A DIFFERENCE WOULD THAT MAKE IN YOUR DECISION TO SEEK CARE.)

W5

(CHECK ONLY ONE ANSWER)

- 1. 0 = NO DIFFERENCE
- 2. 1
- 3. 2
- 4. 3
- 5. 4
- 6. 5
- 7. 6
- 8. 7
- 9. 8

- 10. 9
- 11. 10 = HUGE DIFFERENCE
- 12. (DO NOT READ) REFUSE
- 13. (DO NOT READ) DON'T KNOW/NO ANSWER

IF (#116 = 6) GO TO #138

122. "My doctor would tell me I need medication."
(READ AS OFTEN AS NEEDED: "HOW MUCH OF A DIFFERENCE
WOULD THAT MAKE IN YOUR DECISION TO SEEK CARE.)

W6

(CHECK ONLY ONE ANSWER)

- 1. 0 = NO DIFFERENCE
- 2. 1
- 3. 2
- 4. 3
- 5. 4
- 6. 5
- 7. 6
- 8. 7
- 9. 8
- 10. 9
- 11. 10 = HUGE DIFFERENCE
- 12. (DO NOT READ) REFUSE
- 13. (DO NOT READ) DON'T KNOW/NO ANSWER

IF (#116 = 7) GO TO #138

123. "I would feel better about myself."
(READ AS OFTEN AS NEEDED: "HOW MUCH OF A DIFFERENCE
WOULD THAT MAKE IN YOUR DECISION TO SEEK CARE.)

W7

(CHECK ONLY ONE ANSWER)

- 1. 0 = NO DIFFERENCE
- 2. 1
- 3. 2
- 4. 3
- 5. 4
- 6. 5
- 7. 6
- 8. 7
- 9. 8
- 10. 9
- 11. 10 = HUGE DIFFERENCE
- 12. (DO NOT READ) REFUSE
- 13. (DO NOT READ) DON'T KNOW/NO ANSWER

IF (#116 = 8) GO TO #138

124. "I would be able to resume my normal activities."
(READ AS OFTEN AS NEEDED: "HOW MUCH OF A DIFFERENCE

WOULD THAT MAKE IN YOUR DECISION TO SEEK CARE.)

W8

(CHECK ONLY ONE ANSWER)

- 1. 0 = NO DIFFERENCE
- 2. 1
- 3. 2
- 4. 3
- 5. 4
- 6. 5
- 7. 6
- 8. 7
- 9. 8
- 10. 9
- 11. 10 = HUGE DIFFERENCE
- 12. (DO NOT READ) REFUSE
- 13. (DO NOT READ) DON'T KNOW/NO ANSWER

IF (#116 = 9) GO TO #138

125. "I would be told to do Kegel exercises."

(READ AS OFTEN AS NEEDED: "HOW MUCH OF A DIFFERENCE
WOULD THAT MAKE IN YOUR DECISION TO SEEK CARE.)

W9

(CHECK ONLY ONE ANSWER)

- 1. 0 = NO DIFFERENCE
- 2. 1
- 3. 2
- 4. 3
- 5. 4
- 6. 5
- 7. 6
- 8. 7
- 9. 8
- 10. 9
- 11. 10 = HUGE DIFFERENCE
- 12. (DO NOT READ) REFUSE
- 13. (DO NOT READ) DON'T KNOW/NO ANSWER

IF (#116 = 10) GO TO #138

126. "My doctor would tell me it is normal after having children."

(READ AS OFTEN AS NEEDED: "HOW MUCH OF A DIFFERENCE
WOULD THAT MAKE IN YOUR DECISION TO SEEK CARE.)

W10

(CHECK ONLY ONE ANSWER)

- 1. 0 = NO DIFFERENCE
- 2. 1
- 3. 2
- 4. 3
- 5. 4
- 6. 5

- 7. 6
- 8. 7
- 9. 8
- 10. 9
- 11. 10 = HUGE DIFFERENCE
- 12. (DO NOT READ) REFUSE
- 13. (DO NOT READ) DON'T KNOW/NO ANSWER

IF (#116 = 11) GO TO #138

127. "I would find out it was a common medical condition."
 (READ AS OFTEN AS NEEDED: "HOW MUCH OF A DIFFERENCE
 WOULD THAT MAKE IN YOUR DECISION TO SEEK CARE.)

W11

(CHECK ONLY ONE ANSWER)

- 1. 0 = NO DIFFERENCE
- 2. 1
- 3. 2
- 4. 3
- 5. 4
- 6. 5
- 7. 6
- 8. 7
- 9. 8
- 10. 9
- 11. 10 = HUGE DIFFERENCE
- 12. (DO NOT READ) REFUSE
- 13. (DO NOT READ) DON'T KNOW/NO ANSWER

IF (#116 = 12) GO TO #138

128. "I would regain control of my bladder."
 (READ AS OFTEN AS NEEDED: "HOW MUCH OF A DIFFERENCE
 WOULD THAT MAKE IN YOUR DECISION TO SEEK CARE.)

W12

(CHECK ONLY ONE ANSWER)

- 1. 0 = NO DIFFERENCE
- 2. 1
- 3. 2
- 4. 3
- 5. 4
- 6. 5
- 7. 6
- 8. 7
- 9. 8
- 10. 9
- 11. 10 = HUGE DIFFERENCE
- 12. (DO NOT READ) REFUSE
- 13. (DO NOT READ) DON'T KNOW/NO ANSWER

IF (#116 = 13) GO TO #138

129. "I would get information about my diagnosis and
(READ AS OFTEN AS NEEDED: "HOW MUCH OF A DIFFERENCE
WOULD THAT MAKE IN YOUR DECISION TO SEEK CARE.)
treatment options."

W13

(CHECK ONLY ONE ANSWER)

- 1. 0 = NO DIFFERENCE
- 2. 1
- 3. 2
- 4. 3
- 5. 4
- 6. 5
- 7. 6
- 8. 7
- 9. 8
- 10. 9
- 11. 10 = HUGE DIFFERENCE
- 12. (DO NOT READ) REFUSE
- 13. (DO NOT READ) DON'T KNOW/NO ANSWER

IF (#116 = 14) GO TO #138

130. "I would find out if my symptoms were from a serious illness
(READ AS OFTEN AS NEEDED: "HOW MUCH OF A DIFFERENCE
WOULD THAT MAKE IN YOUR DECISION TO SEEK CARE.)
like cancer."

W14

(CHECK ONLY ONE ANSWER)

- 1. 0 = NO DIFFERENCE
- 2. 1
- 3. 2
- 4. 3
- 5. 4
- 6. 5
- 7. 6
- 8. 7
- 9. 8
- 10. 9
- 11. 10 = HUGE DIFFERENCE
- 12. (DO NOT READ) REFUSE
- 13. (DO NOT READ) DON'T KNOW/NO ANSWER

IF (#116 = 15) GO TO #138

131. "I would be told to lose weight."
(READ AS OFTEN AS NEEDED: "HOW MUCH OF A DIFFERENCE
WOULD THAT MAKE IN YOUR DECISION TO SEEK CARE.)

W15

(CHECK ONLY ONE ANSWER)

- 1. 0 = NO DIFFERENCE

- 2.1
- 3.2
- 4.3
- 5.4
- 6.5
- 7.6
- 8.7
- 9.8
- 10.9
- 11. 10 = HUGE DIFFERENCE
- 12. (DO NOT READ) REFUSE
- 13. (DO NOT READ) DON'T KNOW/NO ANSWER

IF (#116 = 16) GO TO #138

132. "I would be referred to a specialist."
 (READ AS OFTEN AS NEEDED: "HOW MUCH OF A DIFFERENCE
 WOULD THAT MAKE IN YOUR DECISION TO SEEK CARE.)

W16

(CHECK ONLY ONE ANSWER)

- 1. 0 = NO DIFFERENCE
- 2.1
- 3.2
- 4.3
- 5.4
- 6.5
- 7.6
- 8.7
- 9.8
- 10.9
- 11. 10 = HUGE DIFFERENCE
- 12. (DO NOT READ) REFUSE
- 13. (DO NOT READ) DON'T KNOW/NO ANSWER

IF (#116 = 17) GO TO #138

133. "My quality of life would improve."
 (READ AS OFTEN AS NEEDED: "HOW MUCH OF A DIFFERENCE
 WOULD THAT MAKE IN YOUR DECISION TO SEEK CARE.)

W17

(CHECK ONLY ONE ANSWER)

- 1. 0 = NO DIFFERENCE
- 2.1
- 3.2
- 4.3
- 5.4
- 6.5
- 7.6
- 8.7
- 9.8
- 10.9
- 11. 10 = HUGE DIFFERENCE

12. (DO NOT READ) REFUSE
 13. (DO NOT READ) DON'T KNOW/NO ANSWER

IF (#116 = 18) GO TO #138

134. "I would be told that there is nothing that can be done."
(READ AS OFTEN AS NEEDED: "HOW MUCH OF A DIFFERENCE
WOULD THAT MAKE IN YOUR DECISION TO SEEK CARE.)

W18

(CHECK ONLY ONE ANSWER)

1. 0 = NO DIFFERENCE
 2. 1
 3. 2
 4. 3
 5. 4
 6. 5
 7. 6
 8. 7
 9. 8
 10. 9
 11. 10 = HUGE DIFFERENCE
 12. (DO NOT READ) REFUSE
 13. (DO NOT READ) DON'T KNOW/NO ANSWER

IF (#116 = 19) GO TO #138

135. "I would resume normal social relationships."
(READ AS OFTEN AS NEEDED: "HOW MUCH OF A DIFFERENCE
WOULD THAT MAKE IN YOUR DECISION TO SEEK CARE.)

W19

(CHECK ONLY ONE ANSWER)

1. 0 = NO DIFFERENCE
 2. 1
 3. 2
 4. 3
 5. 4
 6. 5
 7. 6
 8. 7
 9. 8
 10. 9
 11. 10 = HUGE DIFFERENCE
 12. (DO NOT READ) REFUSE
 13. (DO NOT READ) DON'T KNOW/NO ANSWER

IF (#116 = 20) GO TO #138

136. "My doctor would tell me I need surgery."
(READ AS OFTEN AS NEEDED: "HOW MUCH OF A DIFFERENCE
WOULD THAT MAKE IN YOUR DECISION TO SEEK CARE.)

W20

(CHECK ONLY ONE ANSWER)

- 1. 0 = NO DIFFERENCE
- 2. 1
- 3. 2
- 4. 3
- 5. 4
- 6. 5
- 7. 6
- 8. 7
- 9. 8
- 10. 9
- 11. 10 = HUGE DIFFERENCE
- 12. (DO NOT READ) REFUSE
- 13. (DO NOT READ) DON'T KNOW/NO ANSWER

IF (#116 = 21) GO TO #138

137. "I would be told it was caused by something I had done in my past."
(READ AS OFTEN AS NEEDED: "HOW MUCH OF A DIFFERENCE
WOULD THAT MAKE IN YOUR DECISION TO SEEK CARE.)

W21

(CHECK ONLY ONE ANSWER)

- 1. 0 = NO DIFFERENCE
- 2. 1
- 3. 2
- 4. 3
- 5. 4
- 6. 5
- 7. 6
- 8. 7
- 9. 8
- 10. 9
- 11. 10 = HUGE DIFFERENCE
- 12. (DO NOT READ) REFUSE
- 13. (DO NOT READ) DON'T KNOW/NO ANSWER

IF (#116 = 1) GO TO #138

SKIP TO QUESTION 117

138. In the following section, I will ask about barriers
to seeking care. To what extent do the following
prevent you from seeking care for uncontrollable
urine leakage. Please respond by answering not at all,
slightly, moderately, or greatly.

XVOID

PRESS ENTER TO CONTINUE

139. Randomize

XRANDOM

(CHECK ONLY ONE ANSWER)

- 1. SKIP TO X1 (GO TO QUESTION 140)
- 2. SKIP TO X2 (GO TO QUESTION 141)
- 3. SKIP TO X3 (GO TO QUESTION 142)
- 4. SKIP TO X4 (GO TO QUESTION 143)
- 5. SKIP TO X5 (GO TO QUESTION 144)
- 6. SKIP TO X6 (GO TO QUESTION 145)
- 7. SKIP TO X7 (GO TO QUESTION 146)
- 8. SKIP TO X8 (GO TO QUESTION 147)
- 9. SKIP TO X9 (GO TO QUESTION 148)
- 10. SKIP TO X10 (GO TO QUESTION 149)
- 11. SKIP TO X11 (GO TO QUESTION 150)
- 12. SKIP TO X12 (GO TO QUESTION 151)
- 13. SKIP TO X13 (GO TO QUESTION 152)
- 14. SKIP TO X14 (GO TO QUESTION 153)
- 15. SKIP TO X15 (GO TO QUESTION 154)
- 16. SKIP TO X16 (GO TO QUESTION 155)
- 17. SKIP TO X17 (GO TO QUESTION 156)
- 18. SKIP TO X18 (GO TO QUESTION 157)
- 19. SKIP TO X19 (GO TO QUESTION 158)

SKIP TO QUESTION 159

140. READ AS OFTEN AS NECESSARY: TO WHAT EXTENT DOES THE FOLLOWING PREVENT YOU FROM SEEKING CARE FOR UNCONTROLLABLE URINE LEAKAGE. "I don't have a health care practitioner who will see me for uncontrollable urine leakage."

X1

(CHECK ONLY ONE ANSWER)

- 1. Not at all
- 2. Slightly
- 3. Moderately
- 4. Greatly
- 5. (DO NOT READ) REFUSE
- 6. (DO NOT READ) DON'T KNOW/NO ANSWER

IF (#139 = 2) GO TO #159

141. READ AS OFTEN AS NECESSARY: TO WHAT EXTENT DOES THE FOLLOWING PREVENT YOU FROM SEEKING CARE FOR UNCONTROLLABLE URINE LEAKAGE. "I don't know how to get an appointment with a health care practitioner."

X2

(CHECK ONLY ONE ANSWER)

- 1. Not at all
- 2. Slightly
- 3. Moderately
- 4. Greatly
- 5. (DO NOT READ) REFUSE
- 6. (DO NOT READ) DON'T KNOW/NO ANSWER

IF (#139 = 3) GO TO #159

142. READ AS OFTEN AS NECESSARY: TO WHAT EXTENT DOES THE FOLLOWING PREVENT YOU FROM SEEKING CARE FOR UNCONTROLLABLE URINE LEAKAGE.

"There are long delays before insurance repays out-of-pocket expenses."

X3

(CHECK ONLY ONE ANSWER)

- 1. Not at all
- 2. Slightly
- 3. Moderately
- 4. Greatly
- 5. (DO NOT READ) REFUSE
- 6. (DO NOT READ) DON'T KNOW/NO ANSWER

IF (#139 = 4) GO TO #159

143. READ AS OFTEN AS NECESSARY: TO WHAT EXTENT DOES THE FOLLOWING PREVENT YOU FROM SEEKING CARE FOR UNCONTROLLABLE URINE LEAKAGE.

"My insurance too complicated to figure out."

X4

(CHECK ONLY ONE ANSWER)

- 1. Not at all
- 2. Slightly
- 3. Moderately
- 4. Greatly
- 5. (DO NOT READ) REFUSE
- 6. (DO NOT READ) DON'T KNOW/NO ANSWER

IF (#139 = 5) GO TO #159

144. READ AS OFTEN AS NECESSARY: TO WHAT EXTENT DOES THE FOLLOWING PREVENT YOU FROM SEEKING CARE FOR UNCONTROLLABLE URINE LEAKAGE.

"I don't have medical insurance."

X5

(CHECK ONLY ONE ANSWER)

- 1. Not at all
- 2. Slightly
- 3. Moderately
- 4. Greatly
- 5. (DO NOT READ) REFUSE
- 6. (DO NOT READ) DON'T KNOW/NO ANSWER

IF (#139 = 6) GO TO #159

145. READ AS OFTEN AS NECESSARY: TO WHAT EXTENT DOES THE FOLLOWING PREVENT YOU FROM SEEKING CARE FOR UNCONTROLLABLE URINE LEAKAGE.

"The cost of having my uncontrollable urine leakage

evaluated is too high."

X6

(CHECK ONLY ONE ANSWER)

- 1. Not at all
- 2. Slightly
- 3. Moderately
- 4. Greatly
- 5. (DO NOT READ) REFUSE
- 6. (DO NOT READ) DON'T KNOW/NO ANSWER

IF (#139 = 7) GO TO #159

146. READ AS OFTEN AS NECESSARY: TO WHAT EXTENT DOES THE FOLLOWING PREVENT YOU FROM SEEKING CARE FOR UNCONTROLLABLE URINE LEAKAGE. "The cost of lost wages is too high."

X7

(CHECK ONLY ONE ANSWER)

- 1. Not at all
- 2. Slightly
- 3. Moderately
- 4. Greatly
- 5. (DO NOT READ) REFUSE
- 6. (DO NOT READ) DON'T KNOW/NO ANSWER

IF (#139 = 8) GO TO #159

147. READ AS OFTEN AS NECESSARY: TO WHAT EXTENT DOES THE FOLLOWING PREVENT YOU FROM SEEKING CARE FOR UNCONTROLLABLE URINE LEAKAGE. "There is no transportation to the office or clinic."

X8

(CHECK ONLY ONE ANSWER)

- 1. Not at all
- 2. Slightly
- 3. Moderately
- 4. Greatly
- 5. (DO NOT READ) REFUSE
- 6. (DO NOT READ) DON'T KNOW/NO ANSWER

IF (#139 = 9) GO TO #159

148. READ AS OFTEN AS NECESSARY: TO WHAT EXTENT DOES THE FOLLOWING PREVENT YOU FROM SEEKING CARE FOR UNCONTROLLABLE URINE LEAKAGE. "The cost of transportation to the office or clinic is too high."

X9

(CHECK ONLY ONE ANSWER)

- 1. Not at all
- 2. Slightly
- 3. Moderately

- 4. Greatly
- 5. (DO NOT READ) REFUSE
- 6. (DO NOT READ) DON'T KNOW/NO ANSWER

IF (#139 = 10) GO TO #159

149. READ AS OFTEN AS NECESSARY: TO WHAT EXTENT DOES THE FOLLOWING PREVENT YOU FROM SEEKING CARE FOR UNCONTROLLABLE URINE LEAKAGE. "The wait it too long at the time of the appointment."

X10

(CHECK ONLY ONE ANSWER)

- 1. Not at all
- 2. Slightly
- 3. Moderately
- 4. Greatly
- 5. (DO NOT READ) REFUSE
- 6. (DO NOT READ) DON'T KNOW/NO ANSWER

IF (#139 = 11) GO TO #159

150. READ AS OFTEN AS NECESSARY: TO WHAT EXTENT DOES THE FOLLOWING PREVENT YOU FROM SEEKING CARE FOR UNCONTROLLABLE URINE LEAKAGE. "The office or clinic is too far away."

X11

(CHECK ONLY ONE ANSWER)

- 1. Not at all
- 2. Slightly
- 3. Moderately
- 4. Greatly
- 5. (DO NOT READ) REFUSE
- 6. (DO NOT READ) DON'T KNOW/NO ANSWER

IF (#139 = 12) GO TO #159

151. READ AS OFTEN AS NECESSARY: TO WHAT EXTENT DOES THE FOLLOWING PREVENT YOU FROM SEEKING CARE FOR UNCONTROLLABLE URINE LEAKAGE. "Appointments have to be scheduled too far ahead."

X12

(CHECK ONLY ONE ANSWER)

- 1. Not at all
- 2. Slightly
- 3. Moderately
- 4. Greatly
- 5. (DO NOT READ) REFUSE
- 6. (DO NOT READ) DON'T KNOW/NO ANSWER

IF (#139 = 13) GO TO #159

152. READ AS OFTEN AS NECESSARY: TO WHAT EXTENT DOES THE FOLLOWING

PREVENT YOU FROM SEEKING CARE FOR UNCONTROLLABLE URINE LEAKAGE.
"Office hmys at the office or clinic are limited."

X13

(CHECK ONLY ONE ANSWER)

- 1. Not at all
- 2. Slightly
- 3. Moderately
- 4. Greatly
- 5. (DO NOT READ) REFUSE
- 6. (DO NOT READ) DON'T KNOW/NO ANSWER

IF (#139 = 14) GO TO #159

153. READ AS OFTEN AS NECESSARY: TO WHAT EXTENT DOES THE FOLLOWING
PREVENT YOU FROM SEEKING CARE FOR UNCONTROLLABLE URINE LEAKAGE.
"I am unable to arrange for childcare."

X14

(CHECK ONLY ONE ANSWER)

- 1. Not at all
- 2. Slightly
- 3. Moderately
- 4. Greatly
- 5. (DO NOT READ) REFUSE
- 6. (DO NOT READ) DON'T KNOW/NO ANSWER

IF (#139 = 15) GO TO #159

154. READ AS OFTEN AS NECESSARY: TO WHAT EXTENT DOES THE FOLLOWING
PREVENT YOU FROM SEEKING CARE FOR UNCONTROLLABLE URINE LEAKAGE.
"I don't like to be examined or asked a lot of questions."

X15

(CHECK ONLY ONE ANSWER)

- 1. Not at all
- 2. Slightly
- 3. Moderately
- 4. Greatly
- 5. (DO NOT READ) REFUSE
- 6. (DO NOT READ) DON'T KNOW/NO ANSWER

IF (#139 = 16) GO TO #159

155. READ AS OFTEN AS NECESSARY: TO WHAT EXTENT DOES THE FOLLOWING
PREVENT YOU FROM SEEKING CARE FOR UNCONTROLLABLE URINE LEAKAGE.
"The physician or nurse practitioner doesn't take time to
explain what he or she is doing or why, or answer my questions."

X16

(CHECK ONLY ONE ANSWER)

- 1. Not at all
- 2. Slightly

- 3. Moderately
- 4. Greatly
- 5. (DO NOT READ) REFUSE
- 6. (DO NOT READ) DON'T KNOW/NO ANSWER

IF (#139 = 17) GO TO #159

156. READ AS OFTEN AS NECESSARY: TO WHAT EXTENT DOES THE FOLLOWING PREVENT YOU FROM SEEKING CARE FOR UNCONTROLLABLE URINE LEAKAGE. "I am afraid to find out if I have a serious problem."

X17

(CHECK ONLY ONE ANSWER)

- 1. Not at all
- 2. Slightly
- 3. Moderately
- 4. Greatly
- 5. (DO NOT READ) REFUSE
- 6. (DO NOT READ) DON'T KNOW/NO ANSWER

IF (#139 = 18) GO TO #159

157. READ AS OFTEN AS NECESSARY: TO WHAT EXTENT DOES THE FOLLOWING PREVENT YOU FROM SEEKING CARE FOR UNCONTROLLABLE URINE LEAKAGE. "For some reason, I am afraid of the health care practitioner."

X18

(CHECK ONLY ONE ANSWER)

- 1. Not at all
- 2. Slightly
- 3. Moderately
- 4. Greatly
- 5. (DO NOT READ) REFUSE
- 6. (DO NOT READ) DON'T KNOW/NO ANSWER

IF (#139 = 19) GO TO #159

158. READ AS OFTEN AS NECESSARY: TO WHAT EXTENT DOES THE FOLLOWING PREVENT YOU FROM SEEKING CARE FOR UNCONTROLLABLE URINE LEAKAGE. "The health care practitioner and his staff aren't interested in my worries about my health."

X19

(CHECK ONLY ONE ANSWER)

- 1. Not at all
- 2. Slightly
- 3. Moderately
- 4. Greatly
- 5. (DO NOT READ) REFUSE
- 6. (DO NOT READ) DON'T KNOW/NO ANSWER

IF (#139 = 1) GO TO #159

SKIP TO QUESTION 140

159. In the final section, I will ask general questions about health and illness. Please respond by answering: strongly disagree, moderately disagree, slightly disagree, slightly agree, moderately agree, or strongly agree.

YVOID

PRESS ENTER TO CONTINUE

160. Randomize

YRANDOM

(CHECK ONLY ONE ANSWER)

- 1. SKIP TO Y1 (GO TO QUESTION 161)
- 2. SKIP TO Y2 (GO TO QUESTION 162)
- 3. SKIP TO Y3 (GO TO QUESTION 163)
- 4. SKIP TO Y4 (GO TO QUESTION 164)
- 5. SKIP TO Y5 (GO TO QUESTION 165)
- 6. SKIP TO Y6 (GO TO QUESTION 166)
- 7. SKIP TO Y7 (GO TO QUESTION 167)
- 8. SKIP TO Y8 (GO TO QUESTION 168)
- 9. SKIP TO Y9 (GO TO QUESTION 169)
- 10. SKIP TO Y10 (GO TO QUESTION 170)
- 11. SKIP TO Y11 (GO TO QUESTION 171)
- 12. SKIP TO Y12 (GO TO QUESTION 172)
- 13. SKIP TO Y13 (GO TO QUESTION 173)
- 14. SKIP TO Y14 (GO TO QUESTION 174)
- 15. SKIP TO Y15 (GO TO QUESTION 175)
- 16. SKIP TO Y16 (GO TO QUESTION 176)
- 17. SKIP TO Y17 (GO TO QUESTION 177)
- 18. SKIP TO Y18 (GO TO QUESTION 178)

SKIP TO QUESTION 181

161. If I get sick, it is my own behavior which determines how soon I get well again. Do you . . .

Y1

(CHECK ONLY ONE ANSWER)

- 1. Strongly disagree
- 2. Moderately disagree,
- 3. Slightly disagree,
- 4. Slightly agree,
- 5. Moderately agree, or
- 6. Strongly agree.
- 7. (DO NOT READ) REFUSE
- 8. (DO NOT READ) DON'T KNOW/NO ANSWER

IF (#160 = 2) GO TO #181

162. Having regular contact with my physician is the best way for me to avoid illness.

Y2

(CHECK ONLY ONE ANSWER)

- 1. Strongly disagree
- 2. Moderately disagree,
- 3. Slightly disagree,
- 4. Slightly agree,
- 5. Moderately agree, or
- 6. Strongly agree.
- 7. (DO NOT READ) REFUSE
- 8. (DO NOT READ) DON'T KNOW/NO ANSWER

IF (#160 = 3) GO TO #181

163. No matter what, if I'm going to get sick, I will get sick.

Y3

(CHECK ONLY ONE ANSWER)

- 1. Strongly disagree
- 2. Moderately disagree,
- 3. Slightly disagree,
- 4. Slightly agree,
- 5. Moderately agree, or
- 6. Strongly agree.
- 7. (DO NOT READ) REFUSE
- 8. (DO NOT READ) DON'T KNOW/NO ANSWER

IF (#160 = 4) GO TO #181

164. I am in control of my own health.

Y4

(CHECK ONLY ONE ANSWER)

- 1. Strongly disagree
- 2. Moderately disagree,
- 3. Slightly disagree,
- 4. Slightly agree,
- 5. Moderately agree, or
- 6. Strongly agree.
- 7. (DO NOT READ) REFUSE
- 8. (DO NOT READ) DON'T KNOW/NO ANSWER

IF (#160 = 5) GO TO #181

165. Whenever I don't feel well, I should consult a medically trained professional.

Y5

(CHECK ONLY ONE ANSWER)

- 1. Strongly disagree
- 2. Moderately disagree,

- 3. Slightly disagree,
- 4. Slightly agree,
- 5. Moderately agree, or
- 6. Strongly agree.
- 7. (DO NOT READ) REFUSE
- 8. (DO NOT READ) DON'T KNOW/NO ANSWER

IF (#160 = 6) GO TO #181

166. Most things that affect my health happen to me by accident.

Y6

(CHECK ONLY ONE ANSWER)

- 1. Strongly disagree
- 2. Moderately disagree,
- 3. Slightly disagree,
- 4. Slightly agree,
- 5. Moderately agree, or
- 6. Strongly agree.
- 7. (DO NOT READ) REFUSE
- 8. (DO NOT READ) DON'T KNOW/NO ANSWER

IF (#160 = 7) GO TO #181

167. When I get sick, I am to blame.

Y7

(CHECK ONLY ONE ANSWER)

- 1. Strongly disagree
- 2. Moderately disagree,
- 3. Slightly disagree,
- 4. Slightly agree,
- 5. Moderately agree, or
- 6. Strongly agree.
- 7. (DO NOT READ) REFUSE
- 8. (DO NOT READ) DON'T KNOW/NO ANSWER

IF (#160 = 8) GO TO #181

168. My family has a lot to do with my becoming sick or staying healthy.

Y8

(CHECK ONLY ONE ANSWER)

- 1. Strongly disagree
- 2. Moderately disagree,
- 3. Slightly disagree,
- 4. Slightly agree,
- 5. Moderately agree, or
- 6. Strongly agree.
- 7. (DO NOT READ) REFUSE
- 8. (DO NOT READ) DON'T KNOW/NO ANSWER

IF (#160 = 9) GO TO #181

169. Luck plays a big part in determining how soon I will
recover from an illness. ____

Y9

(CHECK ONLY ONE ANSWER)

- 1. Strongly disagree
- 2. Moderately disagree,
- 3. Slightly disagree,
- 4. Slightly agree,
- 5. Moderately agree, or
- 6. Strongly agree.
- 7. (DO NOT READ) REFUSE
- 8. (DO NOT READ) DON'T KNOW/NO ANSWER

IF (#160 = 10) GO TO #181

170. The main thing which affects my health is what I myself do.

Y10

(CHECK ONLY ONE ANSWER)

- 1. Strongly disagree
- 2. Moderately disagree,
- 3. Slightly disagree,
- 4. Slightly agree,
- 5. Moderately agree, or
- 6. Strongly agree.
- 7. (DO NOT READ) REFUSE
- 8. (DO NOT READ) DON'T KNOW/NO ANSWER

IF (#160 = 11) GO TO #181

171. Health professionals control my health.

Y11

(CHECK ONLY ONE ANSWER)

- 1. Strongly disagree
- 2. Moderately disagree,
- 3. Slightly disagree,
- 4. Slightly agree,
- 5. Moderately agree, or
- 6. Strongly agree.
- 7. (DO NOT READ) REFUSE
- 8. (DO NOT READ) DON'T KNOW/NO ANSWER

IF (#160 = 12) GO TO #181

172. My good health is largely a matter of good fortune.

Y12

(CHECK ONLY ONE ANSWER)

- 1. Strongly disagree
- 2. Moderately disagree,
- 3. Slightly disagree,
- 4. Slightly agree,
- 5. Moderately agree, or
- 6. Strongly agree.
- 7. (DO NOT READ) REFUSE
- 8. (DO NOT READ) DON'T KNOW/NO ANSWER

IF (#160 = 13) GO TO #181

173. If I take care of myself, I can avoid illness.

Y13

(CHECK ONLY ONE ANSWER)

- 1. Strongly disagree
- 2. Moderately disagree,
- 3. Slightly disagree,
- 4. Slightly agree,
- 5. Moderately agree, or
- 6. Strongly agree.
- 7. (DO NOT READ) REFUSE
- 8. (DO NOT READ) DON'T KNOW/NO ANSWER

IF (#160 = 14) GO TO #181

174. When I recover from an illness, it's because other people (for example, doctors, nurses, family, friends) have been taking good care of me.

Y14

(CHECK ONLY ONE ANSWER)

- 1. Strongly disagree
- 2. Moderately disagree,
- 3. Slightly disagree,
- 4. Slightly agree,
- 5. Moderately agree, or
- 6. Strongly agree.
- 7. (DO NOT READ) REFUSE
- 8. (DO NOT READ) DON'T KNOW/NO ANSWER

IF (#160 = 15) GO TO #181

175. No matter what I do, I'm likely to get sick.

Y15

(CHECK ONLY ONE ANSWER)

- 1. Strongly disagree
- 2. Moderately disagree,
- 3. Slightly disagree,
- 4. Slightly agree,
- 5. Moderately agree, or

- 6. Strongly agree.
- 7. (DO NOT READ) REFUSE
- 8. (DO NOT READ) DON'T KNOW/NO ANSWER

IF (#160 = 16) GO TO #181

176. If I take the right actions, I can stay healthy.

Y16

(CHECK ONLY ONE ANSWER)

- 1. Strongly disagree
- 2. Moderately disagree,
- 3. Slightly disagree,
- 4. Slightly agree,
- 5. Moderately agree, or
- 6. Strongly agree.
- 7. (DO NOT READ) REFUSE
- 8. (DO NOT READ) DON'T KNOW/NO ANSWER

IF (#160 = 17) GO TO #181

177. Regarding my health, I can only do what my doctor tells me.

Y17

(CHECK ONLY ONE ANSWER)

- 1. Strongly disagree
- 2. Moderately disagree,
- 3. Slightly disagree,
- 4. Slightly agree,
- 5. Moderately agree, or
- 6. Strongly agree.
- 7. (DO NOT READ) REFUSE
- 8. (DO NOT READ) DON'T KNOW/NO ANSWER

IF (#160 = 18) GO TO #181

178. If it's meant to be, I will stay healthy.

Y18

(CHECK ONLY ONE ANSWER)

- 1. Strongly disagree
- 2. Moderately disagree,
- 3. Slightly disagree,
- 4. Slightly agree,
- 5. Moderately agree, or
- 6. Strongly agree.
- 7. (DO NOT READ) REFUSE
- 8. (DO NOT READ) DON'T KNOW/NO ANSWER

IF (#160 = 19) GO TO #181

SKIP TO QUESTION 161

179. I'm sorry, we are only interviewing people
who are between 35 and 85 years old for this survey.
Thank you so much for your time.

V_ADULT

PRESS ENTER TO CONTINUE

SKIP TO QUESTION 187

180. We are only interviewing women who have experienced
this problem at sometime in the past 12 months.
Thank you so much for your time.

NOT_ELIG

PRESS ENTER TO CONTINUE

SKIP TO QUESTION 187

181. READ: That's my last question. Thank you very much
for your assistance.

INTERVIEWER INSTRUCTIONS: HANG UP. ENTER 1 OR 2

-

1 = COMPLETED INTERVIEW

2 = AN INCOMPLETE INTERVIEW. YOU WILL GO TO TOP OF QUESTIONNAIRE.

FINISHA

LOWEST VALUE = 1

HIGHEST VALUE = 2

IF (#181 = 2) GO TO #17

182. CODE "#26" BY ENTERING THE NUMBER FROM THE TABLES.

Q6A

183. Compute GREEN SES

Q6B

COMPUTE ((0.7 * #25 + 0.4 * #182) - 30)

184. Compute GREEN SES

Q6C

(CHECK ONLY ONE ANSWER)

1. Undetermined

2. Low SES

|_ 3. High SES

COMPUTE IF (#183 <= 28) 3

COMPUTE IF (#183 >= 29) 2

APPENDIX 2

Expectations of Incontinence Care Seeking Questionnaire (EICS-Q)

In the following questions, I will ask about your expectations when seeking care for uncontrollable urine leakage. What do you think is likely to happen if you seek care. On a scale of 0 to 10 where 0 represents "not at all likely" and 10 represents "definitely likely". Answer choices 5 and 6 do not represent "I don't know". Remember, I'd like you to consider your expectations when seeking care.

(INTERVIEWER NOTE: Responses are based on her expectations when seeking care, not her actual experience when seeking care.)

(READ AS OFTEN AS NEEDED: WHEN SEEKING CARE FOR UNCONTROLLABLE URINE LEAKAGE, HOW LIKELY WOULD IT BE THAT THIS WOULD HAPPEN?)

"I would regain control of my life."	V2	Control
"I would be labeled a hypochondriac."	V3	Int Fear/Anxiety
"I would be embarrassed."	V4	Int Fear/Anxiety
"I would feel better about myself."	V7	Control
"I would be able to resume my normal activities."	V8	Control
"I would regain control of my bladder."	V12	Control
"I would be referred to a specialist."	V16	Ext Fear/Anxiety
"My quality of life would improve."	V17	Control
"I would be told that there is nothing that can be done."	V18	Int Fear/Anxiety
"I would resume normal social relationships."	V19	Control
"I would be told it was caused by something I had done in my past."	V21	Int Fear/Anxiety
"My doctor would tell me I need surgery."	V20	Ext Fear/Anxiety

- 1. 0 = NOT AT ALL LIKELY
- 2. 1
- 3. 2
- 4. 3
- 5. 4
- 6. 5
- 7. 6
- 8. 7
- 9. 8
- 10. 9
- 11. 10 = DEFINITELY LIKELY

Scoring the questionnaire

Bolded items represent negative expectations of incontinence care seeking and are recoded so "definitely likely" is scored a 1 and "not at all likely" is scored an 11. Control, Internal Fear/Anxiety. External Fear/Anxiety subscale scores are calculated by a summation of the individual item scores. An overall Expectation of incontinence care seeking score is calculated as a summation of the Control, Internal Fear/Anxiety, and External Fear/Anxiety subscale scores. Higher Expectations scores should be associated with an increased probability of incontinence care seeking. The lower anchor score associated with "not at all likely" should be coded as 0 if the expectation questionnaire is used alone or 1 when used with the value questionnaire to calculate a utility score of incontinence care seeking (sum of the products of expectation and corresponding value scores).

APPENDIX 3

Barrier to Incontinence Care Seeking Questionnaire (BICS-Q)

In the following section, I will ask about barriers to seeking care. To what extent do the following prevent you from seeking care for uncontrollable urine leakage. Please respond by answering not at all, slightly, moderately, or greatly.

INTERVIEWER NOTE: READ AS OFTEN AS NECESSARY: HOW MUCH OF A BARRIER TO SEEKING CARE IS:

"I don't have a health care practitioner who will see me for uncontrollable urine leakage."	X1	Relationship
"There are long delays before insurance repays out-of-pocket expenses."	X3	Cost
"My insurance too complicated to figure out."	X4	Cost
"The cost of having my uncontrollable urine leakage evaluated is too high."	X6	Cost
"There is no transportation to the office or clinic."	X8	Site-related
"The wait is too long at the time of the appointment."	X10	Inconvenience
"The office or clinic is too far away."	X11	Site-related
"Appointments have to be scheduled too far ahead."	X12	Inconvenience
"Office hours at the office or clinic are limited."	X13	Inconvenience
"I don't like to be examined or asked a lot of questions."	X15	Fear
"The physician or nurse practitioner doesn't take time to explain what he or she is doing or why, or answer my questions."	X16	Relationship
"I am afraid to find out if I have a serious problem."	X17	Fear
"For some reason, I am afraid of the health care practitioner."	X18	Fear
"The health care practitioner and his staff aren't interested in my worries about my health."	X19	Relationship

- 1. 0 = Not at all
- 2. 1 = Slightly
- 3. 2 = Moderately
- 4. 3 = Greatly

Scoring the questionnaire

Inconvenience, Relationship, Site-related, Cost, and Fear subscale scores are calculated by a summation of the individual item scores. An overall Barriers for incontinence care seeking score is calculated as a summation of the Inconvenience, Relationship, Site-related, Cost, and Fear subscale scores. Higher Barrier scores should be associated with a decreased probability of incontinence care seeking. The lower anchor score associated with "not at all" should be coded as 0 suggesting no barriers for incontinence care seeking.

CURRICULUM VITAE

Michael H. Heit, M.D., MSPH

914 N. Dixie Avenue, Suite 104
Elizabethtown, Kentucky 42701
Tel # (270)-763-1711
Fax # (270) -763-1193

Email: mheit@louisville.edu

Home Address: 4525 Wolf Creek Pkwy
Louisville, KY 40241
(502)-228-6956

Date of Birth: July 23, 1962 Place of Birth: Queens, New York
Citizenship: USA

Marital Status: Married Wife: Michelle

Social Security #066-62-5422 Children: Meaghan Elizabeth, Kaitlyn Michelle

ACADEMIC DEGREES

Undergraduate Education

June 1984 BS with honors State University of New York at Binghamton,
Vestal, NY [Biochemistry]

Graduate Education

July 1988 MD St. Louis University School of Medicine, St. Louis, MO
June 2001 MSPH University of Louisville, Clinical Investigative Sciences
June 2001- PhD candidate University of Louisville, Clinical Investigative Sciences

Postdoctoral Clinical Training

July 1988-June 1992	Residency	ObGyn	Washington University Medical Center, St. Louis, MO
July 1991-June 1992	Administrative Chief	ObGyn	Washington University Medical Center, St. Louis, MO
July 1992-May 1994	Fellowship	Urogyn	Rush Presbyterian St. Luke's Medical Center, Chicago, IL

ACADEMIC AND PROFESSIONAL EXPERIENCE

Faculty Appointments

July 1992-May 1994	Instructor	Department of Obstetrics and Gynecology Rush-Presbyterian St. Luke's Medical Center, Chicago, IL
July 1994-June 1996	Instructor	Department of Obstetrics and Gynecology, University of Louisville, Louisville, KY
July 1996-June 2000	Asst Prof	Department of Obstetrics and Gynecology University of Louisville, Louisville, KY
July 2001-Dec 2003	Assoc Prof w/Tenure	Department of Obstetrics and Gynecology University of Louisville, Louisville, KY
Jan 2004-present	Physician	Urogynecology Specialists of KY, PLLC

Hospital Staff Appointments

July 1994-present	Medical staff	University of Louisville Hospital, Louisville, KY
July 1994-present	Medical staff	Norton Hospital, Louisville, KY
July 1994-present	Medical staff	Jewish Hospital, Louisville, KY
July 1994-present	Medical staff	Norton Suburban, Louisville, KY
July 1994-present	Medical staff	Norton Audubon, Louisville, KY
July 1994-present	Medical staff	Baptist Hospital East, Louisville, KY

MEDICAL LICENSURE

Physician & Surgeon: Kentucky, 30391	DEA Registration:	BH3272058
Indiana, 01046813	DEA Registration:	BH5722017

BOARD CERTIFICATION

American Board of Ob/Gyn Nov. 15, 1996

PROFESSIONAL SOCIETIES

July 1988-present	Fellow	American College of Ob/Gyn
July 1992-present	Member	American Urogynecologic Society
July 1992-present	Member	International Continence Society
July 1992-present	Member	International Urogynecological Association
July 1992-present	Fellow	American College of Surgeons
July 1992-present	Member	Louisville Ob/Gyn Society
July 1992-present	Member	Jefferson County Medical Association
July 1992-present	Member	Society of Gynecologic Surgeons

EDITORIAL BOARDS, ADVISORY COUNCILS AND COMMITTEES

Editorial Boards

Jan 2004-present International Urogyn J and Pelvic Floor Dysfunction

Committees - Department of Obstetrics and Gynecology

July 1991-June 1992	Review Committee	Washington University Medical Center, St. Louis, MO
July 1994-June 1995	Interv Eval Committee	University of Louisville, Louisville, KY

Committees - Hospital

July 1997-June 1998	Ob/Gyn OR Committee	Alliant Health System, Norton Hospital
July 1997-June 1998	OB/Gyn Qual Rev	Alliant Health System, Norton Hospital

Committees - Private Office

July 1997-June 1998	PSC Planning Committee	University OB/GYN Associates, Louisville, KY
---------------------	------------------------	--

Committees – National

July 2003-present AUGS Research Committee

Ad Hoc Jmynal Reviewer

International Urogynecology Jmynal and Pelvic Floor Dysfunction
American Jmynal of Surgery
Obstetrics & Gynecology
American Jmynal of Obstetrics and Gynecology
Jmynal of the American Association of Gynecologic Laparoscopists

Directorates and Similar Academic Appointments

July 1982-June 1984 Biology T. A. SUNY/Binghamton, Vestal, NY
July 1988-June 1992 Instructor ObGyn Washington University, St. Louis, MO
July 1992-June 1994 Instructor ObGyn Rush Medical College, Chicago, IL
July 1994-Dec 2004 Director Division of Female Pelvic Medicine and
Reconstructive Surgery
University of Louisville, Louisville, KY
July 1994-Dec 2004 Director Women's Pavilion Continence Center, Alliant
Medical Pavilion, Louisville, KY
July 2001-Dec 2004 Director ABOG/ABU Accredited Fellowship program in
Female Pelvic Medicine And Reconstructive
Surgery

EDUCATIONAL HONORS AND AWARDS

June 1988 Honors in Biochemistry
June 1988 Clinical Externship honors in Gynecologic Oncology (University of
Michigan, Ann Arbor, MI)
June 1990 Clinical Clerkship honors in Internal Medicine
June 1992 Outstanding Teaching Professor, University of Louisville Department of
Ob/Gyn
June 1994 Advisor, Searle Resident Research Paper Award, Second Place District VI
ACOG
June 1997 Outstanding Teaching Professor, University of Louisville Department of
Ob/Gyn
June 1997 CREOG National Faculty Award for Excellence in Resident Education
June 1998 Outstanding Teaching Professor, University of Louisville Department of
Ob/Gyn
June 2002 Outstanding Teaching Professor, University of Louisville Department of
Ob/Gyn
May 2003 Outstanding Achievement Award. Outstanding Accomplishments in
Clinical Research and Academic Medicine, University of Louisville,

CREST Program

COMMUNITY SERVICE

July 2000	Director	Continuing Medical Education Cmyse, First Annual Women's Health Issues: Urinary Incontinence and Pelvic Organ Prolapse. University of Louisville
July 2001	Co-Director	Continuing Medical Education Cmyse, Second Annual Women's Health Issues: Urinary Incontinence and Pelvic Organ Prolapse. University of Louisville
July 2002	Co-Director	Continuing Medical Education Cmyse, Third Annual Conference on Incontinence & Pelvic Organ Prolapse. University of Louisville
Jul 02-Jul 02	President	Louisville Ob/Gyn Society

BIBLIOGRAPHY

A. Publications

Peer-Reviewed

- (1) Brubaker L, Heit M. Radiology of the pelvic floor. In Clinical Obstetrics and Gynecology, Delancey JOL (ed), JB Lippincott Company, Philadelphia, PA, 36:952, 1993.
- (2) Heit M, Brubaker L. "Urodynamic Equipment: Making the Right Choice." Contemp Ob/Gyn 40:49-58, 1995.
- (3) Heit M, Benson JT, Russell B, Brubaker L. Levator Ani Muscle in Women with Genitmyinary Prolapse: Indirect Assessment by Muscle Histopathology. Neurmyology and Urodynamics 1996;15:17-29.
- (4) Heit M, Brubaker L. Clinical Correlates in Patients not Completing a Voiding Diary. Int Urogynecol J 1996;7:256-259.
- (5) Heit M. Infectious Peritonitis Complicating Suprapubic Catheter Removal. Int Urogynecol J 1997;8:47-49.
- (6) Heit M. Prolonged Urinary Retention Following Collagen Periurethral Injections: A Sequela of Humoral Immunity. Obstet Gynecol 1997;90(4):693-5.
- (7) Heit M, Brubaker L. An Alternative Statistical Approach for Predicting Prolonged

Catheterization after Burch Colposuspension. *Int Urogynecol J* 1997;8:203-208.

- (8) Tao YX, Heit M, Lei ZM, Rao CV. The Urinary Bladder of a Woman is a Novel Site of Luteinizing Hormone/ Human Chorionic Gonadotropin Receptor Gene Expression. *Am J Obstet Gynecol* 1998;179(4):1026-31.
- (9) Heit M. Endoluminal Ultrasound of the Urethra: A New Technology Awaiting Further Investigation. *J Pelvic Surg* 1999;5:22-31.
- (10) Fischer J, Heit M, Clark M, Benson JT. Correlation of Intraurethral Ultrasonography and Needle Electromyography of the Urethra. *Obstet Gynecol* 2000;95(1):156-9.
- (11) Heit M. Intraurethral Ultrasonography: Correlation of Urethral Anatomy with Functional Urodynamic Parameters. *Int Urogynecol J* 2000;11(4):204-211.
- (12) Heit M, Pasic R, Levine R. Suture Placement During Retropubic Urethropexy. *Int Urogynecol J* 2001; 12(1):42-45.
- (13) Soergel T, Shott S, Heit M. Poor Surgical Outcomes After Fascia Lata Allograft Slings. *Int Urogynecol J* 2001;12(4):247-253.
- (14) Culligan P, Heit M. Urinary Incontinence in Women: Evaluation and Management. *Am Fam Physician* 2000;62(1):2433-44.
- (15) Heit M, Mudd K, Culligan P. Prevention of Childbirth Injuries to the Pelvic Floor. *Current Women's Health Reports*; 1:72-80, 2001.
- (16) Heit M, Culligan P, Rosenquist C, Shott S. Is Pelvic Organ Prolapse a Cause of Pelvic or Low Back Pain. *Obstet Gynecol* 2002;99(1):23-28.
- (17) Major H, Culligan P, Heit M. Urethral Sphincter Morphology in Women with Detrusor Instability. *Obstet Gynecol* 2002;99(1):63-68.
- (18) Heit M. Intraurethral Ultrasonography and the Test-Retest Reliability of Sphincter Measurements. *J Clinical Ultrasound* 2002;30(6):349-55.
- (19) Culligan PJ, Koduri S, Heit MH, Rackley R, Thomson RB, Schwabe L, Goldberg RP, Bent AE, Nihira M, Sand, PK. The Safety of Reusing Injectable Collagen: A Multicenter Microbiological Study. *International Urogynecology Jmynal* 2002;13(4):232-235.
- (20) Rardin, CR, Rosenblatt, PL, Kohli, N, Miklos, JR, Heit, M, Lucente, VR. Release of Tension-Free Vaginal Tape for the Treatment of Refractory Postoperative

Voiding Dysfunction. *Obstet Gynecol* 2002; 100(5):898-902.

- (21) Heit M. What is the Scientific Evidence for Bone Anchor Use During Bladder Neck Suspension? *Int. Urogynecol J* 2002;13(3):143-144.
- (22) Culligan P, Hill S, Heit M. Rupture of the Symphysis Pubis During Vaginal Delivery Followed by Two Subsequent Uneventful Pregnancies. *Obstet Gynecol* 2002;100(5 part 2):1114-1117.
- (23) Culligan P, Murphy M, Blackwell L, Hammons G, Graham C, Heit M. Long-term Success of Sacral Colpopexy Using Synthetic Mesh. *Am J Obstet Gynecol* 2002;187(6):1473-1482.
- (24) Culligan PJ, Miklos JR, Murphy M, Goldberg R, Graham CA, Moore R, Hainer M, Heit MH. The tensile strength of uterosacral ligament sutures: A comparison of vaginal and laparoscopic techniques. *Obstet Gynecol* 2003;101(3):500-503.
- (25) Murphy M, Heit M, Fouts L, Graham C, Blackwell L, & Culligan P. Effect of Anesthesia on Voiding Function Following Tension-Free Vaginal Tape. *Obstet Gynecol* 2003;101(4):666-670.
- (26) Heit M, Rosenquist C, Culligan P, Graham C, Murphy M, & Shott S. Predicting treatment choice for patients with pelvic organ prolapse. *Obstet Gynecol* 2003;101(6):1279-1284.
- (27) Culligan PJ, Heit MH, Blackwell L, Graham CA, Smith M, Snyder J. Bacterial colony counts during vaginal surgery. *Infectious Diseases in Obstetrics and Gynecology* 2003; 11:161-165.
- (28) Heit M, Blackwell L, Thomas S, Ouseph R. The Prevalence and Severity of Urinary Incontinence in Kidney Transplant Recipients. *Obstet Gynecol* 2004;103: 352-358.
- (29) Murphy M, Heit M, Culligan PJ. Evaluation and treatment of female urinary incontinence. *American Jmynal of Medicine and Sports*. 2004; 6(2):70-7.
- (30) Kubik K, Blackwell L, Heit M. Does Socioeconomic Status Explain Racial Differences in Urinary Incontinence Knowledge? *Am J Obstet Gynecol* 2004; 191:199-193
- (31) Murphy M, Culligan P, Graham C, Kubik K, Attum O, Heit M. Is the Leak Point Pressure Alone Always an Accurate Indicator of Intrinsic Sphincter Deficiency? Accepted by *International Urogynecology Jmynal and Pelvic Floor Dysfunction* 2004.

- (32) Heit M, Blackwell L, Ouseph R. The Impact of Urinary Incontinence on Activities of Daily Living in Kidney Transplant Recipients. Accepted by International Urogynecology Jmynal and Pelvic Floor Dysfunction 2004.
- (33) Nygaard I, Heit M. Stress Incontinence; Clinical Gynecologic Series: An Expert's View. Obstet Gynecol 2004;104:607-620.

Non Peer-Reviewed

- (1) Heit M. "Potential Stress Urinary Incontinence." Issues in Incontinence, Saxe Healthcare Communications 1(3):2-6, 1995.
- (2) Heit M. "Episiotomy: To Cut or Not To Cut?" PCC Newsletter. University of Louisville 22(12):1-4,1995.
- (3) Heit M. "Potential Stress Urinary Incontinence: Are Asymptomatic Patients with Severe Genitmyinary Prolapse Truly Dry?" Ob/Gyn on Call. University of Louisville 4(1):1-2, 1995.
- (4) Heit M. Dynamic Cystoproctology: Are We Willing to Live Without It. Louisville Medicine 44(7): 306-307, 1996.
- (5) Heit M, Culligan P. Evaluation and Management of Stress Urinary Incontinence in the New Millennium. Louisville Medicine; 48:79-81, 2000.
- (6) Heit M. Technologic Advances in the Management of Women with Urinary Incontinence. Louisville Medicine; 50:99-101, August 2002.

B. Abstracts

- (1) Heit M, Brubaker L, Benson JT, Russell B. The Variability of Levator Ani Muscle in the Human Female. American Uro-Gynecologic Society and the Uro-Dynamics Society Annual Scientific Meeting; San Antonio, TX, November 1993. Int Urogynecol J 1993;397.
- (2) Heit M, Brubaker L, Benson JT, Russell B. The Variability of Levator Ani Muscle in the Human Female. Women's Urological Symposium NIH Conference, March 1994.
- (3) Heit M. The Blank Voiding Diary: Clinical Significance in a Urogynecologic Practice. American Uro-Gynecologic Society annual clinical meeting, September 1994. Int Urogynecol J 5(6): 386.
- (4) Heit M, Vogt V, Brubaker L. Predicting Prolonged Catheterization after Burch

- Colposuspension: A New Statistical Approach. American Uro-Gynecologic Society annual clinical meeting, September 1994. *Int Urogynecol J* 5(6): 385.
- (5) Heit M, Vogt V, Brubaker L. Predicting Prolonged Catheterization after Burch Colposuspension: A New Statistical Approach. Presented by V. Vogt at District VI, American College of Ob/Gyn annual clinical meeting, September 1994. Awarded Searle Resident Research Award, Second Place.
 - (6) Tao YX, Heit M, Lei ZM, Rao CV, Trigone of Human Urinary Bladder is a Novel Site of Luteinizing Hormone/Chorionic Gonadotropin Receptor Expression. Poster Presentation at the Society for Gynecologic Investigation March 1996.
 - (7) TaoYX, Heit M, Lei ZM, Rao CV, Trigone of Human Urinary Bladder is a Novel Site of Luteinizing Hormone/Chorionic Gonadotropin Receptor Expression. Poster Presentation 1996 American Urogynecologic Society, New Orleans, LA. *Int Urogynecol J* (1996) 7:302.
 - (8) Heit M. Intraurethral Ultrasound; Correlation Of Urethral Sphincter Morphology With Functional Urodynamic Parameters. Oral Presentation 1997 American Urogynecologic Society, Tucson, Arizona. *Int Urogynecol J* 1997;8:252.
 - (9) Levine R, Heit M, Pasic R, A Preliminary Comparison Of Vaginal Template And Modified Burch Colposuspension For Suture Placement In Retropubic Urethropexy. 1997 annual clinical meeting of the American Association for Gynecologic Laparoscopists.
 - (10) Heit M, Newton M, Goldsmith LJ, Attum O, Visual Evaluation of the Anterior Vaginal Wall Compared to Q-Tip Testing for Bladder Neck Mobility Assessment. Poster Presentation 1997 American Urogynecologic Society, Tucson, Arizona. *Int Urogynecol J* 1997;8:255.
 - (11) Rosenquist C, O'Conner D, Kleuber K, Attum B, Heit M. Histopathology of the Pudendal Nerve Along its Course in the Female Pelvis. Oral Presentation. District V Junior Fellow Meeting 1997.
 - (12) Heit M, Rosenquist C, O'Conner D, Kleuber K, Attum B, Histopathology of the Pudendal Nerve Along its Course in the Female Pelvis. Oral Presentation. 1998 American Urogynecologic Society, Washington, D.C. *Int Urogynecol J* 1999;10:79.
 - (13) Rosenquist C, Heit M. Is Pelvic Pain A Symptom of Pelvic Organ Prolapse? Poster Presentation. District V Junior Fellow Meeting 1997. Cleveland, OH.
 - (14) Herzog M, Clark A, Heit M. The Influence of Epidural Analgesia on the Development of Postpartum Stress Urinary Incontinence. Poster Presentation. 1998 American Urogynecologic Society, Washington, D.C. *Int Urogynecol J*

1999;10:71.

- (15) Soergel T, Heit M. Suburethral Slings Utilizing Rectus Abdominus Versus Donor Fascia Lata: A Retrospective Study Comparing Objective Cure Rates. Poster Presentation. 1998 American Urogynecologic Society, Washington, D.C. *Int Urogynecol J* 1999;10: 71.
- (16) Fischer J, Heit M, Benson JT, Correlation of Intraurethral Ultrasound with Needle EMG of the Urethra. Poster Presentation. 1998 American Urogynecologic Society, Washington, D.C. *Int Urogynecol J* 1999; 10:87.
- (17) Heit M. Intraurethral Ultrasonography (IUUS): Test-Retest Reliability Of Urethral Sphincter Measurements. Poster Presentation. 1999 American Urogynecologic Society, San Diego, CA.
- (18) Heit M, Pasic R, Levine R. Suture Placement During Retropubic Urethropexy. Oral Presentation. 2000 Annual Meeting of Society of Gynecologic Surgeons. New Orleans, LA.
- (19) Rosenquist C, Heit M. Is pelvic pain a symptom of pelvic organ prolapse? Poster Presentation. 2000 Society of Gynecologic Surgeon's Annual Clinical Meeting and 2000 American Urogynecologic Society annual Clinical Meeting. New Orleans, Louisiana and Hilton Head Island, South Carolina.
- (20) Heit M, Rosenquist C, Culligan P, Shott S. Predictors of treatment choice for patients with pelvic organ prolapse. Oral Presentation. 2000 American Urogynecologic Society Annual Clinical Meeting. Hilton Head Island, South Carolina.
- (21) Majors H, Culligan P, Heit M. Urethral Sphincter Morphology in Women with Detrusor Instability. Oral Presentation. 2001 American Urogynecologic Society Annual Clinical Meeting, Chicago, Illinois.
- (22) Rardin CR, Rosenblatt PL, Kohli N, Miklos JR, Heit M, Lucente VR. Release of Tension-Free Vaginal Tape for the Treatment of Refractory Postoperative Voiding Dysfunction. Oral Presentation. 2001 American Urogynecologic Society Annual Clinical Meeting, Chicago, Illinois.
- (23) Majors H, Culligan P, Heit M. Urethral Sphincter Morphology in Women with Detrusor Instability. Oral Presentation. 2001 International Urogynecology Association Annual Clinical Meeting. Melbourne Australia. *Int Urogynecol J* 2001; 12 Suppl 3: S41.
- (24) Murphy M, Heit M, Fouts L, Graham C, Blackwell L, Culligan PJ. The effect of anesthesia on voiding function following tension-free vaginal tape. Presented at the

American Urogynecologic Society 23rd Annual Scientific Meeting, San Francisco, CA, October 17 – 19, 2002.

- (25) Culligan PJ, Murphy M, Goldberg R, Graham C, Moore R, Hainer M, Heit M, Miklos J. Tensile strength of uterosacral ligament suturing: A comparison of the vaginal and laparoscopic techniques. Presented at the American Urogynecologic Society 23rd Annual Scientific Meeting, San Francisco, CA, October 17 – 19, 2002.
- (26) Heit M, Natraj A, Thomas S, Blackwell L, Ouseph R. Prevalence and Severity of Urinary Incontinence in Kidney Transplant Recipients. Presented at the American Urogynecologic Society 23rd Annual Scientific Meeting, San Francisco, CA, October 17 – 19, 2002.
- (27) Murphy M, Culligan P, Graham C, Kubik K, Attum O, Heit M. Is the Leak Point Pressure Alone Always an Accurate Indicator of Intrinsic Sphincter Deficiency. Poster presentation at the American Urogynecologic Society 24th Annual Scientific Meeting, Hollywood, FL September 11-13, 2003. *J Pelvic Surgery* 2003; 9: 255.
- (28) Culligan P, Myers J, Heit M, Goldberg R, Blackwell L, Gohmann S, Murphy M, Graham C, Abell T. Elective Cesarean Section to Prevent Anal Incontinence and Brachial Plexus Injuries Associated with Macrosomia-A Decision Analysis. Poster presentation at the American Urogynecologic Society 24th Annual Scientific Meeting, Hollywood, FL September 11-13, 2003. *J Pelvic Surgery* 2003; 9: 245.
- (29) Kubik K, Blackwell L, Heit M. Does Socioeconomic Status Explain Differences in Urinary Incontinence Knowledge? Oral poster presentation at the American Urogynecologic Society 24th Annual Scientific Meeting, Hollywood, FL September 11-13, 2003. *J Pelvic Surgery* 2003; 9: 220.
- (30) Culligan P, Habib F, Heit M, Blackwell L, Murphy M, Kubik K, Graham C, Abell T. Elective Cesarean Section to Prevent Anal Incontinence Among Women with a History of Anal Sphincter Disruption During a Prior Vaginal Delivery-A Decision Analysis. Oral presentation at the American Urogynecologic Society 24th Annual Scientific Meeting, Hollywood, FL September 11-13, 2003. *J Pelvic Surgery* 2003; 9: 218
- (31) Culligan P, Blackwell L, Murphy M, Ziegler C, Heit M. A Blinded, Sham-Controlled Trial of Postpartum Extracorporeal Magnetic Inervation to Restore Pelvic Muscle Strength in Primiparous Patients. Oral presentation at the 2004 Joint Meeting of the Society of Gynecologic Surgeons/American Urogynecologic Society Annual Scientific Meeting, San Diego, CA July 29-31, 2004. *J Pelvic Surgery* 2004; 10: S7. Oral poster presentation at the 2004 Joint Meeting of International Continence Society and the International Urogynecologic

Association. 34th Annual Meeting. Paris, France, August 25-27, 2004. *Neuro Urol Urodyn* 2004;23:451.

- (32) Canter M, Blackwell L, Graham C, Heit M. Does Information Bias Threaten the Validity of Surgical Outcomes in a Randomized Trial. Oral presentation at the 2004 Joint Meeting of the Society of Gynecologic Surgeons/American Urogynecologic Society Annual Scientific Meeting, San Diego, CA July 29-31, 2004. *J Pelvic Surgery* 2004; 10: S9.
- (33) Culligan P, Blackwell L, Goldsmith L, Rogers A, Heit M. A Double Blinded, Randomized Controlled Trial Comparing Solvent-Dehydrated Cadaveric Fascia Lata and Polypropylene Mesh for Sacral Colpopexy. Oral presentation at the 2004 Joint Meeting of the Society of Gynecologic Surgeons/American Urogynecologic Society Annual Scientific Meeting, San Diego, CA July 29-31, 2004. *J Pelvic Surgery* 2004; 10: S9.
- (34) Murphy M, Culligan P, Arce C, Graham C, Blackwell L, Heit M. Construct Validity of the Incontinence Severity Index. Oral poster presentation at the 2004 Joint Meeting of the Society of Gynecologic Surgeons/American Urogynecologic Society Annual Scientific Meeting, San Diego, CA July 29-31, 2004. *J Pelvic Surgery* 2004; 10: S25. Oral poster presentation at the 2004 Joint Meeting of International Continence Society and the International Urogynecologic Association. 34th Annual Meeting. Paris, France, August 25-27, 2004. *Neuro Urol Urodyn* 2004;23:530-531.
- (35) Murphy M, Culligan P, Arce C, Graham C, Blackwell L, Heit M. Is the Cough-Stress Test Necessary when Placing the Tension-Free Vaginal Tape. Oral poster presentation at the 2004 Joint Meeting of the Society of Gynecologic Surgeons/American Urogynecologic Society Annual Scientific Meeting, San Diego, CA July 29-31, 2004. *J Pelvic Surgery* 2004; 10: S27.
- (36) Graham C, Murphy M, Heit M. Effects of Estrogen Receptor Agonists on Voiding Function in Hormonally-Altered Female Rats. Oral poster presentation at the 2004 Joint Meeting of the Society of Gynecologic Surgeons/American Urogynecologic Society Annual Scientific Meeting, San Diego, CA July 29-31, 2004. *J Pelvic Surgery* 2004; 10: S34.
- (37) Heit M, Blackwell L, Kelly S. Measuring Patient Expectations for Incontinence Care Seeking. Oral poster presentation at the 2004 Joint Meeting of International Continence Society and the International Urogynecologic Association. 34th Annual Meeting. Paris, France, August 25-27, 2004. *Neuro Urol Urodyn* 2004;23:522-523.

- (38) Heit M, Blackwell L, Kelly S. Measuring Barriers to Incontinence Care Seeking. Oral poster presentation at the 2004 Joint Meeting of International Continence Society and the International Urogynecologic Association. 34th Annual Meeting. Paris, France, August 25-27, 2004. *Neuro Urol Urodyn* 2004;23:523-524.

C. Books And Chapters

- (1) Heit M. Urogynecology. In *Handbook of Primary Care in Ob-Gyn*, Sanfilippo J, and Smith R (eds) Springer-Verlag, New York, NY.
- (2) Brubaker L., Heit M. Use and Care of the Pessary. In *The Female Pelvic Floor: Disorders of Function and Support*, Brubaker L and Saclarides T (eds) F.A. Davis Company, Philadelphia, PA.
- (3) Heit M. Preoperative Evaluation of Recurrent Urogynecology and Reconstructive Pelvic Surgery Disorders. In *Operative Gynecology, Second Edition*, Gershenson D, DeCherney A, Curry S, Brubaker L (eds) W.B. Saunders Co., Orlando, FL.
- (4) Heit M. Detrusor Instability. In *Gynecology for the Primary Care Physician*, Stovall T, Ling F, (eds) Current Medicine. Philadelphia, PA.
- (5) Heit M. A Model for Explaining Differences in Incontinence Care Seeking (MEDICS) Project; Master's Thesis. UMI Dissertation Services. Ann Arbor, MI

D. Editorials, Special Articles and Book Reviews

- (1) Heit M. Book Review; *Female Urology, 2nd Edition*, Edited by Schlomo Raz, *J Pediatric Adolesc Gynecol* 1997;10:227.
- (2) Heit M. Nonsurgical and Surgical Management of Fecal Incontinence and Pessary Use for Pelvic Organ Prolapse. In *Prolog Gynecology*, Fmyth Edition (in Press).
- (3) Heit M. Book Review; *Incontinence, First Edition*, Edited by Lucas M, Emery S, Beynon J. *J Pediatric Adolesc Gynecol* 2001.

PRESENTATIONS

National Meetings

- (1) I) Pelvic floor support defects: Etiology, defect identification and treatment, and prevention. II) Urodynamic evaluation (workshop). *Pelvic Floor Disorders: A Multidisciplinary Conference*. Chicago, IL, October 1993.
- (2) The variability of levator ani muscle in the human female. *American Urogynecologic Society and the Uro-Dynamics Society annual scientific meeting*; San

Antonio, TX, November 1993.

- (3) The variability of levator ani muscle in the human female. Dept. of Obstetrics and Gynecology Annual Network and Resident Seminar. Rush Presbyterian St. Luke's Medical Center, Chicago, IL, April 1994.
- (4) Surgical management of stress urinary incontinence: Building blocks for success. West Virginia Section ACOG Greenbrier Hotel, White Sulpher Springs, West Virginia, August 18, 1994.
- (5) Urodynamic equipment: Making the right choice. Special Interest Group, Annual Meeting of ACOG, Orlando FL, May 1994.
- (6) Urinary Incontinence. Menopause Symposium. Alliant Health Systems and University of Louisville, September 1994.
- (7) Initial Evaluation of the incontinent female patient. Surgical management of stress urinary incontinence I&II. University of Louisville Intensive Ob/Gyn Review Cmyse, Chicago, IL, November 30, 1994.
- (8) Initial Evaluation of the incontinent female patient. Greater Louisville Association of Nurses. Women's Pavilion Health and Resmyce Center, Alliant Health Systems. March 21, 1995.
- (9) Initial Evaluation of the incontinent female patient. Surgical management of stress urinary incontinence Primary Care in Gynecology, University of Louisville, April 26, 1995.
- (10) Episiotomy: To Cut or Not to Cut, That is the Question. 21st Annual High Risk Pregnancy Meeting. University of Louisville, April 28, 1995.
- (11) Genuine stress incontinence; choosing the correct surgery. Special Interest Group, Annual Meeting of ACOG, San Francisco, CA, May 1995.
- (12) I) Pelvic Floor Anatomy, II) Clinical Evaluation of Urinary Incontinence; III) Management of Urinary Incontinence. University of Louisville Intensive Ob-Gyn Review and Update, June 1995.
- (13) Management of Recurrent Stress Urinary Incontinence; What's New. Kentucky Medical Association Annual Clinical Meeting, Section of Ob/Gyn. Lexington, KY, September 19, 1995.
- (14) I) Fecal Incontinence and Constipation II) Evaluation of Functional Disorders of Bowel and Bladder. 63rd Annual Convention and Primary Care Cmyse, American College of Osteopathic Ob/Gyn. San Antonio, Texas, March 21, 1996.

- (15) Endomyology. Advanced Ultrasound and Endoscopic Surgery Cmyse, Alliant Health Systems and University of Louisville, April 22-23, 1996.
- (16) Urinary Incontinence Symposium. Women's Pavilion and the Alliant Health System. Jefferson Mall, Louisville, KY, May 1996.
- (17) Pelvic Organ Prolapse: New Approaches to Diagnosis and Management, Continuing Medical Education Program, Community Methodist Hospital Boardroom Henderson, KY, September 9, 1996.
- (18) Defecography Invited Speaker for Luncheon Discussion AUGS Annual Clinical Meeting, New Orleans, LA, October 1996.
- (19) Pelvic Organ Prolapse: Diagnosis and Management. Invited Speaker, Alliant Adult Service Medical Staff Symposium, December 6, 1996.
- (20) Non-surgical Treatments for Pelvic Relaxation. The Ninth Annual Conference Toward Excellence in Primary Care and Midwifery. The Kentucky Coalition of Nurse Practitioners/Nurse Midwives. The Galt House Hotel, Louisville, KY, April 9-12, 1997.
- (21) Primary Care Issues in Women's Health. I. Office Evaluation of Urinary Incontinence. II. Evaluation and Management of Fecal Incontinence. Twenty-Third Annual High Risk Pregnancy Cmyse.
- (22) Management of Suspected Urologic Injury at the Time of OB/GYN Surgery. Sponsored by Alliant Health.
- (23) System in conjunction with University of Louisville School of Medicine, Department of Obstetrics and Gynecology, The Seelbach Hotel, Louisville, KY, April 21-26, 1997.
- (24) Urinary Incontinence: Nonsurgical management of the incontinent female patient. Clinical symposia, Alliant Health Systems, Louisville, KY, August 1997.
- (25) "You Need a New Hammer, said the Nail". Urinary Incontinence: Research Issues and Opportunities Sponsored by NIDDK and ORWH, NIH Natcher Conference Center Bethesda, MD, Jan 23-24, 1998.
- (26) New Approaches to the Evaluation and Management of Pelvic Organ Prolapse. East Tennessee Ob/Gyn Society, Knoxville, TN, March 12, 1998.
- (27) Evaluation of Urinary Incontinence. Twin Lakes Regional Medical Center, Leitchfield, KY. June 22, 1998.
- (28) Instructor, Advanced Workshop on Gynecologic Laparoscopic Anatomy and

Surgery on Unembalmed Cadavers. Sponsored by the American Association of Gynecologic Laparoscopists in Affiliation with the Department of Obstetrics and Gynecology and the Department of Anatomical Sciences and Neurobiology at the University of Louisville Health Science Center, September 18-19,1998.

- (29) I) Clinical Evaluation of Prolapse and What's the POPQ II) Fecal Incontinence III) Constipation, Invited Speaker. 1998 ACOG District V Junior Fellow Annual District Meeting, Cleveland, OH, October 9-10,1998.
- (30) Urinary Incontinence. Invited Speaker. Menopause Symposium. Presented in conjunction with Alliant Medical Systems and the University of Louisville Department of Obstetrics and Gynecology, Marriott East Hotel, Louisville, KY, November 6, 1998.
- (31) Diagnosing and Managing Urinary Incontinence in the Young and Old. Twentieth Primary Care Review & ACLS for Family Practitioners and Internists, Sponsored by Jewish Hospital in cooperation with the University of Louisville Dept of Family & Community Medicine, Dept. of Internal Medicine and Jewish Hospital Primary Care, Jewish Hospital Rudd Heart and Lung Center, March 28-April 3, 1998.
- (32) New Approaches to Patients with Pelvic Floor Dysfunction and Pelvic Relaxation: Gifts, Gadgets and Gags. Primary Care Issues in Women's Health, April 20-22,1998. Urinary Symptoms and Pregnancy. Twenty-Fmyth Annual High Risk Pregnancy Postgraduate Cmyse. Sponsored by Alliant Health System in conjunction with the University of Louisville Dept. of Ob/Gyn. Seelbach Hilton Hotel, April 23-25, 1998.
- (33) Managing Uterine Prolapse Twenty First Annual Primary Care Review & ACLS for Family Practitioners and Internists, Sponsored by Jewish Hospital in cooperation with the University of Louisville Dept. of Family & Community Medicine, Dept. of Internal Medicine and Jewish Hospital Primary Care, Jewish Hospital Rudd Heart and Lung Center, March 8, 1999.
- (34) I) Overactive Bladder II) Use of Pessaries and Pelvic Appliances. The Eleventh Annual Conference Toward Excellence in Primary Care and Midwifery. The Kentucky Coalition of Nurse Practitioners/Nurse Midwives. The Galt House Hotel, Louisville, KY, April 23-24, 1999.
- (35) Instructor, Advanced Workshop on Gynecologic Laparoscopic Anatomy and Surgery on Unembalmed Cadavers. Sponsored by the American Association of Gynecologic Laparoscopists in Affiliation with the Department of Obstetrics and Gynecology and the Department of Anatomical Sciences and Neurobiology at the University of Louisville Health Science Center, September 6-7, 1999.
- (36) Evaluation and Management of the Overactive Bladder. Grand Rounds, Wright State University, Department of Ob/Gyn. Miami Valley Hospital, January 12, 2000.

- (37) New Technologies in the Management of Stress Urinary Incontinence. Twenty Second Annual Primary Care Review & ACLS for Family Practitioners and Internists, Sponsored by Jewish Hospital in cooperation with the University of Louisville Dept. of Family & Community Medicine, Dept. of Internal Medicine and Jewish Hospital Primary Care, Jewish Hospital Rudd Heart and Lung Center, March 22, 2000.
- (38) Invited Speaker. Pelvic Floor Anatomy using Fresh Tissue Cadavers. Bard Urological Division National Sales Meeting, 2001.
- (39) Invited Speaker. Panel discussion on Diagnostic Imaging in Urogynecology-Ultrasound. American Urogynecology Society Annual Clinical Meeting, 2001.
- (40) Invited Speaker. Panel discussion on the New Anti-Incontinence Procedures: What's the Evidence – Bone Anchors. American Urogynecology Society Annual Clinical Meeting, 2001.
- (41) Invited Speaker. I) Childbirth Injuries to the Pelvic Floor II) Evaluation Management of Fecal Incontinence. The Henry Rappold Annual Symposium on Endoscopy and Advanced Gynecologic Surgery, St. Luke's Hospital, Chesterfield, MO, September 14, 2002.
- (42) Invited Speaker. I) Writing a Study Protocol and Manual II) Writing a Manuscript for Publication. AUGS Fellow Research Retreat, Anaheim, CA, March 3, 2003.
- (43) Invited Speaker. Federal Regulations for Drugs and Surgical Devices. Panel Discussion, 2003 SGS Annual Clinical Meeting, Anaheim, CA, March 6, 2003.
- (44) Invited Speaker AUGS Research Retreat. Multicenter clinical trial development Supported by the AUGS society. Fairfax, Virginia May 2003.
- (45) Invited Speaker. University of Texas Southwestern 1) Manuscript Reading and Writing. 2) Evaluation and Management of Fecal Incontinence. 3) Evaluation and Management of Nocturia. Dallas, TX. July 23, 2003.
- (46) Invited Speaker ACOG District V 2003 Annual Clinical Meeting. 1) Childbirth Injuries to the Pelvic Floor Dearborn, MI November 24-25, 2003.
- (47) Chair, Global Congress of Gynecologic Endoscopy, AAGL 2003 Annual Clinical Meeting Postgraduate Course. Diagnostic Studies and Non-Surgical Management of Urinary and Anal Incontinence. 1) Childbirth Injuries to the Pelvic Floor, 2) Constipation: What Ob/Gyn's Need to Know. Las Vegas, NV, November 19-22, 2003.
- (48) Invited Speaker. Greater Baltimore Medical Center. Grand Rounds. The Evaluation and Management of Nocturia. Baltimore, MD, February 6, 2004

- (49) Invited Speaker. Annual MacKenzie Lecture. Mid-Urethral Slings; What does the Medical Evidence Tell Us. St. Mary's Hospital, Evansville, IN. February 12, 2004.
- (50) Invited Speaker. Washington Medical Center. Grand Rounds. The Evaluation and Management of Nocturia. Baltimore, MD, April 13, 2004.
- (51) Invited Speaker. I) Case Control and Cohort Study Design. II) Writing a Study Protocol and Manual III) Writing a Fundable Grant/Grantsmanship. AUGS Fellow Research Retreat, Chicago, IL May 7-9, 2004
- (52) Invited Speaker. Methodist Hospital/Indiana University Medical Center Grand Rounds. Department of Ob/Gyn The Evaluation and Management of Nocturia. Indiannapolis, IN May 12, 2004.
- (53) Invited Speaker. 2004 AUGS postgraduate research cmyse: Primer on Clinical Research. 1) How to write a study manual. 2) Writing your abstracts & manuscripts to get them accepted. 3) Computer programs for databases; EpiInfo v6.0
- (54) Invited Speaker ACOG District V Junior Fellow ACM. Electronic Medical Records. September 18, 2004.

Local Meetings

- (1) The politics of prolapse. Department of Obstetrics and Gynecology Grand Rounds, Washington University Medical Center, St. Louis, MO, April 1993.
- (2) Constipation. Department of Obstetrics and Gynecology Grand Rounds, Christ Hospital, Oaklawn, IL, March 1994.
- (3) The initial evaluation of the incontinent female patient. Department of Family and Community Medicine Grand Rounds, Jewish Hospital, Louisville, KY, August 5, 1994.
- (4) The initial evaluation of the incontinent female patient. Department of Ob/Gyn Grand Rounds. Norton's Hospital, Louisville, KY, October 4, 1994.
- (5) The initial evaluation of the incontinent female patient. Department of Ob/Gyn Grand Rounds. Owensboro/Daviess Community Hospital, Owensboro, KY, October 20, 1994.
- (6) Surgical Management of Uterovaginal Prolapse; Level I Support Defects. Grand Rounds, Dept. of Ob/Gyn. University of Louisville, October 3, 1995.
- (7) Initial Evaluation of the Incontinent Female Patient, Grand Rounds, Dept. Of Ob/Gyn. Paoli Hospital, Paoli, IN, May 1996.
- (8) The politics of prolapse. Grand Rounds. Baptist East Hospital, Louisville, KY, June

1996.

- (9) Evaluation of the Incontinent Female Patient, Grand Rounds, Regional Medical Center, Madisonville, KY, July 11, 1996.
- (10) Pelvic Organ Prolapse: Diagnosis and Management. Invited Speaker, Regional Medical Center. Medical Staff Grand Rounds, January 10, 1997.
- (11) Evaluation and Management of Anterior Vaginal Wall Support Defects. University of Louisville Grand Rounds, January 14, 1997.
- (12) Urinary Incontinence. Invited guest. Sunday Health Watch. WAVE -TV, February 1997.
- (13) Urinary Incontinence. Invited guest. Call-in Show. WLEX-TV, March 21, 1997.
- (14) Dynamic Cystoproctograms: Their Role In The Evaluation Of Patients With Pelvic Organ Prolapse
Grand Rounds Good Samaritan Hospital, Cincinnati, OH, October 8, 1997.
- (15) The Initial Evaluation and Management of the Incontinent Female Patient. Grand Rounds, University of Tennessee Medical Center at Knoxville, Dept. of Ob/Gyn, March 13, 1998.
- (16) Evaluation and Management of the Overactive Bladder. Grand Rounds, University of Louisville HSC, Dept. of Ob/Gyn, February 23, 1999.
- (17) Incontinence Care Seeking. Grand Rounds, University of Louisville HSC, Dept. of Ob/Gyn, March 2000.
- (18) Pelvic Organ Prolapse. Invited guest. November 2001.
- (19) Evaluation and Management of Nocturia and Enuresis, University of Louisville's 28th Annual Department of Obstetrics and Gynecology Postgraduate Course, April 2-5, 2003.
- (20) Invited Speaker Hardin Memorial Ob/Gyn Departmental Meeting "Reviewing the Medical Literature. July 19, 2004. Elizabethtown, KY

RESEARCH FUNDING

- (1) Title: Levator Ani Muscle Morphology and Innervation in Patients with Prior Abdominal vs. Vaginal Hysterectomy.

- Principal Investigator(s): Michael Heit, MD
Co-investigator(s): Kathleen Kleuber, PhD., Dept. of Anatomy and Neurobiology
Funding: University of Louisville Research Grant
Amount: \$10,000.00
Project Period: 1996-
- (2) Title: Levator Ani Muscle Morphology and Innervation in Patients with Prior Abdominal vs. Vaginal Hysterectomy.
Principal Investigator(s): Michael Heit, MD
Co-investigator(s): Kathleen Kleuber, PhD., Dept. of Anatomy and Neurobiology
Funding: Presidents Research Proposal on Women
Amount: \$3,000.00
Project Period: 1996-
- (3) Title: A Preliminary Comparison of Vaginal Template and Modified Burch Colposuspension for Suture Placement in Retropubic Urethropexy
Co-Investigators: Ronald Levine MD, Michael Heit, MD, Resad Pasic, MD
Funding: UroMed Corporation
Amount: \$13,800.00
Project Period: 1997- 1998
- (4) Title: Retrospective Analysis of the Use of Alloderm[®] for the surgical treatment of stress incontinence
Principal Investigator(s): Michael Heit, MD
Funding: Boston Scientific Microvvasive
Amount: \$2000.00 plus \$50.00/patient enrolled
Project Period: 1999-present
- (5) Title: Extracorporeal Electromagnetic Innervation Therapy to Restore Pelvic Floor Integrity Following Childbirth: A prospective, double-blinded, controlled trial
Principal Investigator(s): P Culligan
Co-Investigator: Michael Heit, MD
Funding: Neotonus, Inc.
Amount: \$128,009
Project Period: 2000-present
- (6) Title: Randomized trial of Synthetic vs. Organic Allograft for Sacral Colpopexy
Principal Investigator(s): Michael Heit, MD
Co-Investigator: P Culligan
Funding: Mentor Corp.
Amount: \$119,500
Project Period: 2000-present
- (7) Title: A Model for Explaining Differences in Incontinence Care Seeking
Principal Investigator(s): Michael Heit, MD
Co-Investigator: Susan Kelly

Funding: NICHD

Amount: \$144,000

Project Period: September 2001 – September 2003

- (8) Title: CARE Study, Pelvic Floor Treatment Network
Subcontracted Investigator: Michael Heit, MD

Funding: NICHD

Amount: \$58,000

Project Period: September 2003 – September 2004

- (9) Title: CAPS Study, Pelvic Floor Treatment Network
Subcontracted Investigator: Michael Heit, MD

Funding: NICHD

Amount: \$58,000

Project Period: September 2003 – September 2004