

# Interaction of DC-link Supply Unit and Supplied Inverters with Regenerative Load

UDK 621.314.57  
 IFAC IA 5.5.4;4.3.1

Professional paper

A technical solution for the group of AC adjustable speed drives supplied from a common DC link has been described. Besides high control demands, the described drives have very fast speed and torque changes, resulting with significant required braking power due to high load inertia. The demands for progressive converter capacitor charging and braking energy recuperation are suggesting application of four-quadrant SCR (Silicon Controlled Rectifier) line converter for supplying common DC link. Basic system properties, problems, solutions and experience acquired during system commissioning have been analyzed, particularly the interaction of DC link supply converter and connected inverters during regenerative braking. The influence of the additional DC link voltage compensation on the system properties in recuperation mode, together with a comparison between the proposed pseudo-derivative feedback (PDF) voltage controller and the cascade PID controller, has been made. The experimental verification of the dynamic system performance during recuperation has been performed in wire rod rolling mill  $\phi 5$ , with high technological production line speed of 100 m/s.

**Key words:** SCR line converter, common DC link, inverters, AC drives, regenerative braking

## 1 INTRODUCTION

In industrial plants, it is often needed to supply several adjustable speed AC drives from a common DC link. Power electronics offers several technical solutions for supplying such drives from AC grid [1, 2].

The technical solution with a common DC link and several inverters supplied from that DC link is used in the case of several low power adjustable speed drives and in the case when a medium power drive is used. In the case of low power drives (effective current up to 370 A), it is possible to use compact AC/AC converters (Figure 1). If a plant has more adjustable speed drives, more convenient system price is achieved using technical solution with the common DC link, supplied from an AC grid with a rectifier (Figure 2). The same is valid in the case of several medium power drives (effective cur-

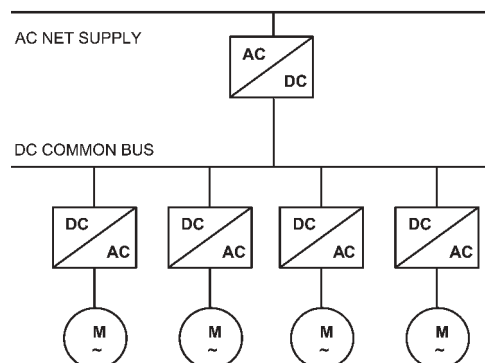

Fig. 2 Group of DC/AC inverters supplied by DC common bus for medium and high power drives

rent 370-1200 A), where each motor has its own inverter, supplied from the common DC link. The reason for this lies in the fact that for such power levels there are no commercially available compact AC/AC drives.

Supplying the DC link from an AC grid is possible with several types of power converters, [1, 2, 4, 5, 6]. Generally, it can be classified according to Table 1.

The final choice of the common DC link supply converter depends on the drive demands (particularly regarding the braking), the converter power factor and the project budget. For high power diode and SCR rectifier units it is possible to use parallel units supplied from two-secondary transformers,

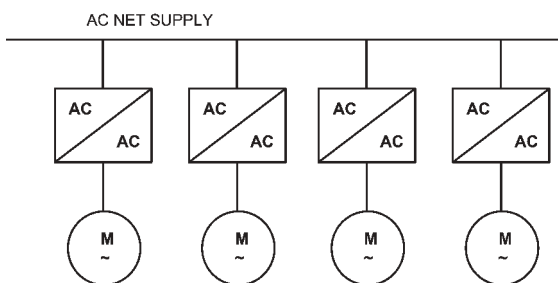

Fig. 1 Group of AC/AC compact inverters for low power drives

Table 1 Types of DC link supply units

DC link supply converter	Advantages	Disadvantages
Diode bridge	– price, simplicity, small dimensions.	– no energy recuperation during braking, – braking units (choppers and resistors) required, – problematic precharging sequence, DC-conductor and precharging circuit required, – high-order harmonics in the main supply.
1-quadrant SCR bridge	– price, simplicity, reliability, – no need of expensive main and pre-charging DC-contactors.	– no energy recuperation during braking, – braking unit required, – high-order harmonics in the main supply.
4-quadrant SCR bridge	– no need of expensive main and precharging DC-contactors and braking units (choppers and resistors).	– sensitivity to net supply voltage variations, – auto transformer necessity (dimensions), – high-order harmonics in the main supply.
PWM converter (Active Front End – AFE)	– no need of expensive main and precharging DC-contactors and braking units (choppers and resistors), – very good filtering of high-order harmonics in the main supply.	– large dimensions, – high price.

resulting with 12-pulse DC voltage, which decreases the high order harmonic content in the mains supply.

Two main competitors for supplying the common DC link from AC grid are four-quadrant SCR line converter and active front end rectifier (AFE). Both solutions are fulfill the main requirements, bidirectional power flow between AC mains and the DC link, as well as control of the DC link voltage. The four-quadrant SCR line converter is well known technical solution based on robust SCR components. With proper control, its main disadvantage, limited output voltage capability when operating in inversion mode and possible commutation problems, can be diminished. On the other side, AFE is an emerging technology, based on IGBT or IGCT components, enabling excellent power factor and bidirectional power flow, [4–6]. Although AFE is surely the technology of the future, the price aspects

have until now been in favour of SCR line converter solutions. Because of the technical properties, reliability and price, the technical solution with 4-quadrant SCR bridge as the common DC link supply is very acceptable and competitive.

## 2 FOUR QUADRANT SCR LINE CONVERTER

In this paper technical solution with 4-quadrant SCR line converter (bridge) is analyzed and some characteristics are experimentally evaluated. The general converter structure is shown in Figure 3.

One group of thyristors supply power to the DC link and supplied inverters, while another group feed power back from the inverters to the AC grid in the phase of regenerative braking. With sophisticated programmed control functions, the SCR bridge can provide controlled common DC link voltage rise. This is important for pre-charging interval du-

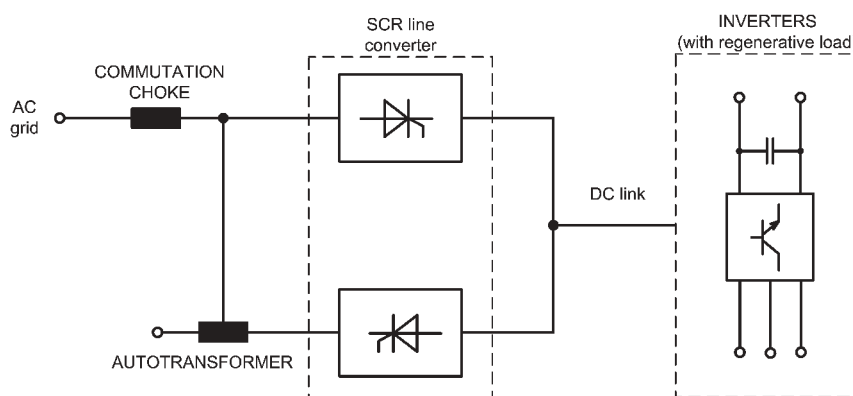

Fig. 3 General structure of SCR line converter

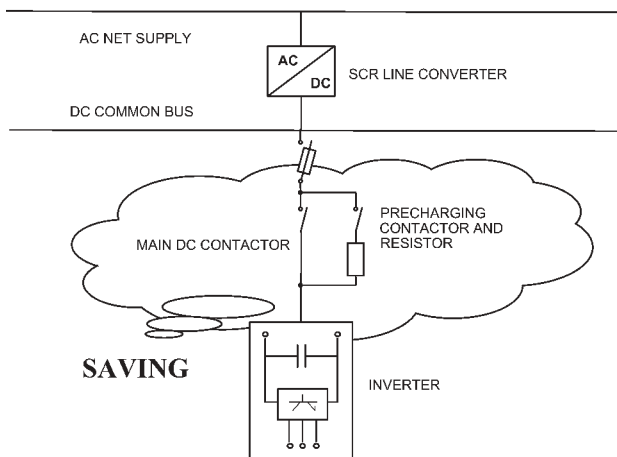

Fig. 4 Switching gears saving using 4-quadrant SCR converter

ring normal turning on (e.g. 0–10 sec) or during capacitor forming (e.g. 0–600 min), if the inverters have not being used for longer time period (more than one year). This function provides significant savings on the DC switch equipment in the DC supply line of each inverter (Figure 4). When using diode rectifier, it is necessary to include the main DC contactor for each inverter circuit consisting of precharging contactor and current limiting resistor. Although resistor limits the current charging the capacitor, the current peaks which decrease capacitor (and converter) life time are inevitable during turn on.

### 2.1 Energy recuperation to mains during braking cycles

During braking, energy surplus appears in the common DC link. The mechanical energy of the rotating mass is converting into electrical, resulting with the increase of the DC link voltage. In simpler solutions (with diode bridge or 1-quadrant SCR line converter), the DC link energy surplus converts via chopper unit and dissipates as heat on braking resistors. The 4-quadrant SCR line converter has an ability to recuperate braking energy to the mains, but with some limitations regarding the voltage levels.

In the case of fast braking of a high inertia loads (high braking power), the common DC link voltage increases. During line converter operation in inverter regime, in order to keep mains voltage constant, the DC link voltage should not exceed a certain value and it should not be allowed that the SCR line converter reaches maximum control angle ( $\alpha_{max}$ ). In that case, the difference between increased DC link voltage and the SCR bridge converter voltage in inverter regime at boundary control angle  $\alpha_{max}$  can not limit the current flowing to the mains. To prevent this situation, the 4-quadrant

SCR bridge is not connected directly to the mains, but a solution with autotransformer (e.g. 1,2 : 1 ratio) is used (Figure 3).

The increased DC link voltage should not exceed the value

$$U_{dc} = 1.35 \cdot U_{lin} \cdot \cos \alpha_{max} - \Delta u, \quad (1)$$

where  $U_{dc}$  is average DC link voltage,  $U_{lin}$  is RMS value of line voltage,  $\alpha_{max}$  is maximum (boundary) control angle for the SCR line converter operating in inverter regime, and  $\Delta u$  is autotransformer and commutation choke voltage drop. Suppose  $\alpha_{max} = 160^\circ$  and  $\Delta u$  is approx. 5 %, an approximate maximum DC link voltage value can be expressed as

$$U_{dc} \approx 1.21 \cdot U_{lin}. \quad (2)$$

The experience has generally shown that in the case of drives having high dynamical requirements, particularly regarding braking, even this 20 % reserve is not enough. An appropriate setup of the SCR line converter's voltage controller is also important. Fast DC link voltage rise during regenerative braking phase requires good dynamic behaviour from the DC link voltage (and current) controller. On the contrary, even dangerous converter operating states can occur. This problem represents the main disadvantage of this technical solution, besides system sensitivity to the mains voltage drops, particularly during regenerative operation. For less demanding drives, a technical solution without autotransformer is possible. In that case, permanent reduction of the DC link voltage, or occasionally predictive lowering of the DC link voltage in case of planned braking has to be done.

### 3 CASE STUDY – SCR CONVERTER IN HOT ROLLING MILL APPLICATION

The experimental analysis of interaction of the DC link and supplied inverters with regenerative load has been conducted in a complex hot rolling mill with the bar and wire rod line. According to technological demands and technical/economical trade-offs (see Table 1), AC-drives are configured in several different ways. The auxiliary AC drives (roller tables, pinch-rolls, chains, conveyors, etc.) are supplied from AC/AC compact inverters, as illustrated in Figure 1. The main drives for the rolling stands are connected to the DC common link and supplied with a diode bridge in combination with a braking chopper and resistor providing braking, see Table 1. A couple of flying shears, which need high braking power, are mixed with stands inverters and supplied from the DC-link with diode bridge braking chopper/resistors (for example: one flying shear with four stands), as shown in Figure 2. It is tech-

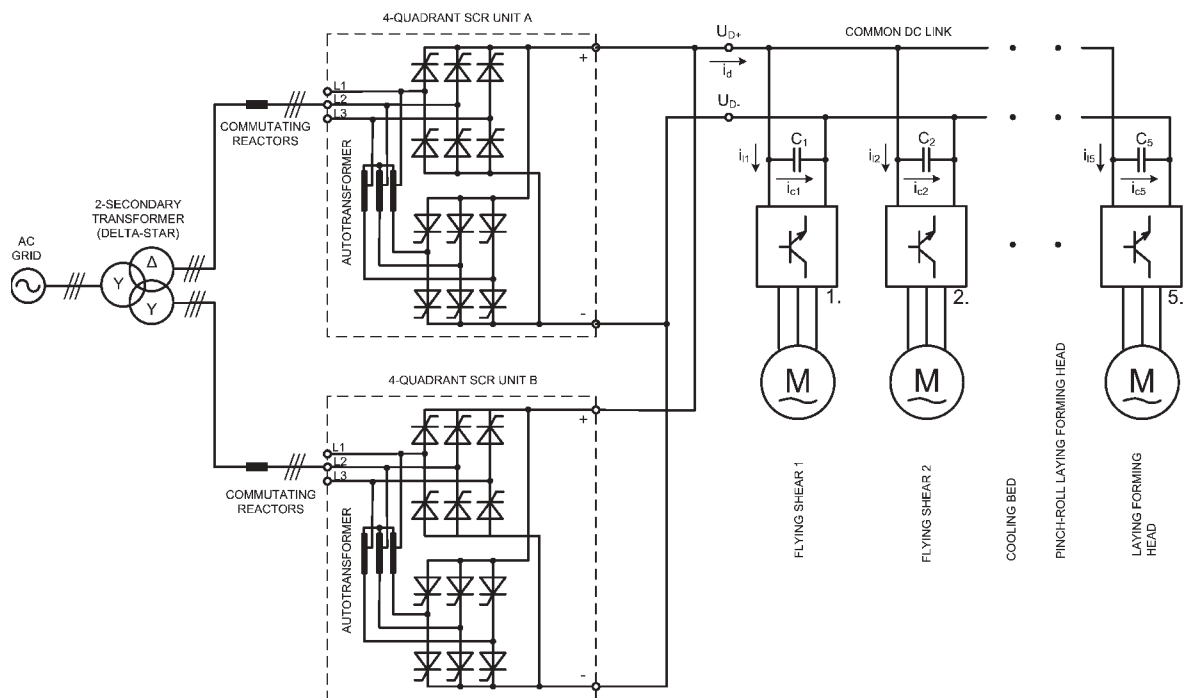

Fig. 5 Structure of technical solution for supplying common DC link from AC grid with 12-pulse converter unit

nically convenient solution to mix regenerative drive with the drives, as rolling stands which mostly run in motoring mode, so that they can absorb voltage peaks caused by regenerative load.

Figure 5 shows the structure of the analyzed technical solution for supplying a common DC link from an AC grid using two 4-quadrant SCR line converter units. This forms a group of the main drives with high dynamic demands and high braking power. It consists of two flying shears, laying forming head, a pinch-roll laying forming head and a cooling bed. Two 4-quadrant SCR line converter units are connected in antiparallel for supplying power to the common DC link and inverters, as well as feeding power back from the common DC link into AC grid. This technical solution requires a transformer with 2 different secondary systems (star and delta) resulting with 30 degree phase shift between two 3-phase output voltage systems. The harmonic loading of the AC supply grid is significantly reduced because of the resulting 12-pulse operation mode.

The heavy and fast duty cycle, e.g. flying shear, is not the only reason for using DC-link with the 4-quadrant SCR line converter. The laying head drive cannot be classified as the drive with high dynamic demand, but it is supplied from the same DC link, because of the huge inertia and high kinetic energy, which can result in energy saving during frequent machine stopping.

### 3.1 Converter control structure

The common DC link voltage  $U_d$  and current  $I_d$  control in a 4-quadrant SCR line converter with autotransformer is shown in Figure 6. It is a cascade control structure with PI voltage controller and subordinated PI current controller with simplified presentation in Figure 7. The current controller is an adaptive controller, for continuous and discontinuous mode of operation, and with preset parameters [7]. The voltage controller is supported with an additional  $U_d$  compensation circuit, realized with total load current  $i_L$  calculated according to Figure 5 as

$$i_L = \sum_{i=1}^n i_{Li} = i_d - \sum_{i=1}^n i_{Ci} = i_d - \frac{dU_d}{dt} \sum_{i=1}^n C_i, \quad (3)$$

where  $n$  is the number of inverters connected to the DC common bus,  $i_{Ln}$  is the load current of  $n^{\text{th}}$  inverter and  $i_{Cn}$  is the current in  $n^{\text{th}}$  capacitor  $C_n$ . Taking  $n=5$  and calculating equivalent capacitor  $C$  of all connected inverters, yields

$$i_L = i_d - C \frac{dU_d}{dt}. \quad (4)$$

The key parameter to be identified is the DC link equivalent capacitance  $C$ , representing the total circuit capacitance of all supplied inverter capacitor banks. According to (4), this parameter is used, together with measured variables  $I_d$  and  $U_d$ , in the part of the DC link voltage compensation (Figure 6).

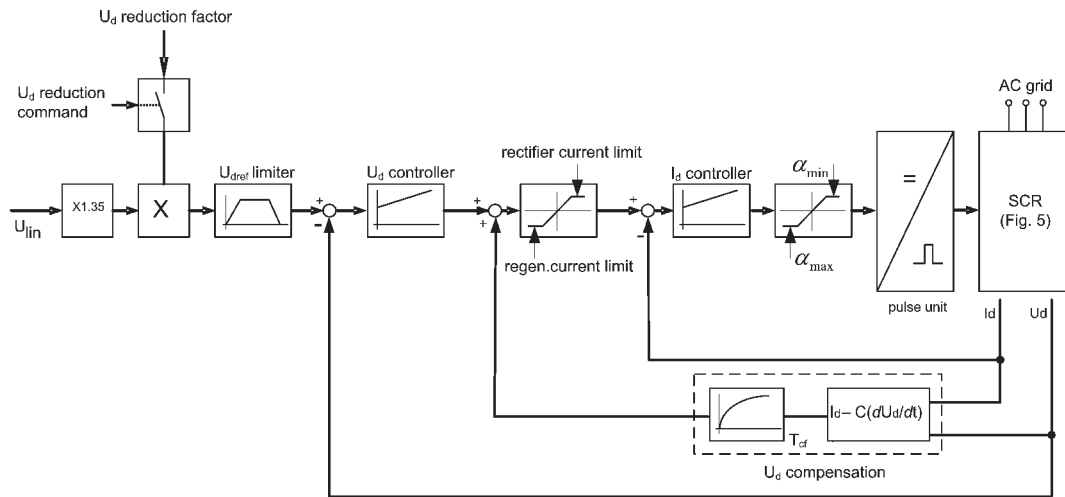

Fig. 6 DC common bus voltage  $U_d$  and current  $I_d$  control in the 4-quadrant SCR converter with autotransformer

The right side of (4) is a derivation of the DC link voltage and can be analyzed as a derivation part of the DC voltage controller. Neglecting the influence of  $I_d$  current compensation, a simplified controllers structure is obtained in Figure 7. Although series (cascade) controllers are the most common because of their simplicity in implementation, depending on the nature of the system, sometimes there are advantages in placing the controller in the minor feedback loop [8, 9]. In that case, the principle of using the derivative term of the control signal to improve damping of a closed loop system can be applied to output controlled variable (DC voltage) instead of an error signal, to achieve a similar effect (Figure 8.a,b). In other words, the derivative of the output DC voltage is fed back and added algebraically to the control signal  $I_{dref}$  of the system, according to (4). Such derivative feedback is often called pseudo-derivative feedback (PDF).

The impact of the derivative part in the cascade controller and PDF controller is analysed for the control structure in a simplified form, neglecting integral part of the controller (Figure 8). The inclu-

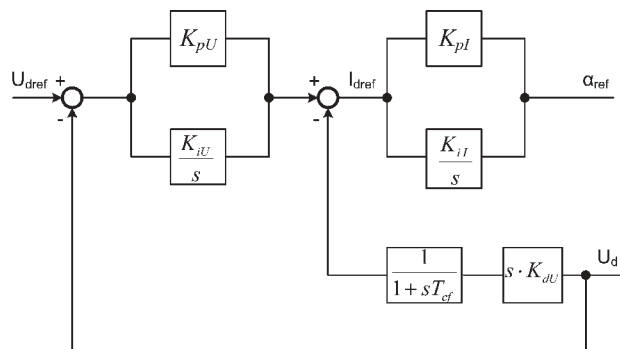

Fig. 7 Simplified control scheme for voltage  $U_d$  and current  $I_d$  controllers

sion of the current  $I_d$  closed controlled loop in the process transfer function  $G_p(s)$  in general form yields

$$G_p(s) = \frac{U_d(s)}{I_{dref}(s)} = \frac{\omega_n^2}{s(s + 2\zeta\omega_n)}, \quad (5)$$

where  $\omega_n$  is the natural frequency and  $\zeta$  is damping coefficient. The closed loop transfer function for the system with PD cascade controller is (Figure 8a.)

$$\frac{U_d(s)}{U_{dref}(s)} = \frac{\omega_n^2(K_{pU} + sK_{dU})}{s^2 + (2\zeta\omega_n + K_{dU}\omega_n^2)s + K_{pU}\omega_n^2} \quad (6)$$

and for the system with PDF controller is (Figure 8b.)

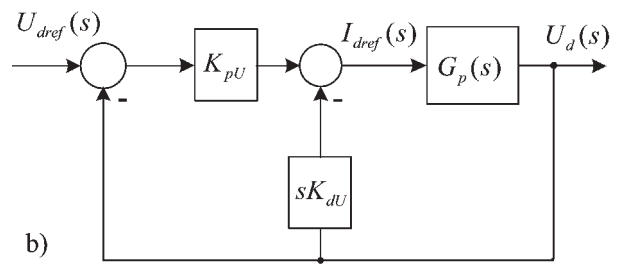
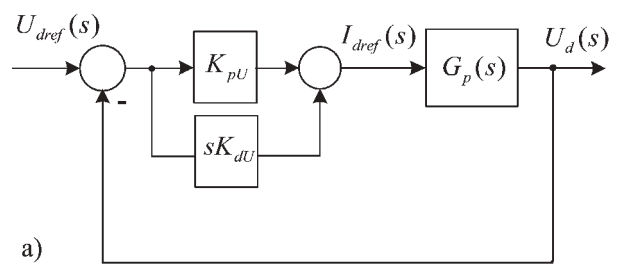

Fig. 8 Cascade (serial) PD controller a) and pseudo-derivative feedback (PDF) controller b)



$$\frac{U_d(s)}{U_{dref}(s)} = \frac{\omega_n^2}{s^2 + (2\xi\omega_n + K_{dU}\omega_n^2)s + K_{pU}\omega_n^2}. \quad (7)$$

The characteristic equation

$$s^2 + (2\xi\omega_n + K_{dU}\omega_n^2)s + K_{pU}\omega_n^2 = 0 \quad (8)$$

is equal for both transfer functions (6) and (7), which means that minor feedback derivate loop (PDF) has exactly the same effect as the derivate action in the cascade controller. By comparing transfer functions (6) and (7) follows that the cascade controller (6) has a zero at  $s = -K_{pU}/K_{dU}$ , whereas equation (7) does not. This is the reason why step response of the cascade controller depends on the characteristic equation poles and zero  $s = -K_{pU}/K_{dU}$ , but step response of the PDF controller is uniquely defined with characteristic equation (8). With identical parameters for both controllers, the PDF controller response is slower but with smaller overshoot than response with cascade controller [8, 9]. This statement is very important for the PDF  $U_d$  controller, because small voltage overshoot is a basic control requirement in SCR line converter control.

Using the PDF voltage controller in Figure 6, the equivalent capacitance  $C$  should be correspond to the derivative gain  $K_{dU}$ . This parameter is automatically changing with total circuit capacitance depending of the number of connected inverters on the DC common link. If it is needed to increase the system performance considering the DC link overshoot, the effect of additional damping in the voltage response can be increased only with carefully decreasing the filter time constant  $T_{cf}$  in the commissioning phase.

#### 4 EXPERIMENTAL RESULTS

The influence of the DC link PI controller parameter settings and the influence of voltage compensation in the DC link voltage control system have been analyzed during the SCR line converter commissioning. The measurements and analyses are performed in the steel factory on the group of wire rod rolling mill  $\phi 5$  drives presented in Table 2.

This process consists 5 of motor drives [7]. The technological producing line speed in wire  $\phi 5$  production is very high, 100 m/s with maximum of 118 m/s (Figure 9). The most significant drive for testing the system in a critical condition considering regenerative braking is the flying shear drive. Because of a very complex technological cycle considering this drive, all experiments have been conducted on the laying forming head (LFH). The supervision after commissioning, in the phase of the wire production, is especially focused on regeneration mode of operation. Careful grouping of different drives to a single SCR line converter and good controller parameter tuning, has resulted in good dynamic performance of the converter during regeneration mode of operation. The regenerative braking is achieved by decreasing the speed of the LFH, and different regeneration load is set by different retardation ramp.

The parameters of the DC link voltage PI controller, proportional gain  $K_{pU}$  and integral time  $T_{iU}$  ( $1/K_{iU}$ ), are defined on the basis of measured DC link voltage and current responses, obtained during characteristic operating regimes, particularly during fast speed changes of one of the connected drives. The regenerative braking tests are the most indicative considering the problems of energy recuperation to the mains during braking cycles.

Under regenerative braking commissioning test, the integral time constant is set high (about 10 s) and the proportional part of the DC voltage controller is increased resulting in maximum 15 % of the DC voltage overshoot. In this experiment,  $U_d$  compensation is turned-off. With  $K_{pU} = 1$ , the integral time constant is decreased in a few consecutive regenerative braking tests. The optimal value of  $T_{iU} = 0,5$  s is set and the results of the test with these parameters for voltage and regenerative current shape are presented in Figure 10. As one can see, in the case of regenerative braking without compensation signal, a 20 % overshoot in the DC link voltage occurs. It has also been proven, that even with the lack of adjustment flexibility of the derivation part of  $U_d$  voltage controller, it is possible to get a considerably smaller voltage transient overshoot in the DC link. By decreasing very careful the filter time constant in the compensation loop,

Table 2 The group of analysed wire rod rolling mill drives

Drive	Converter	Motor
Flying shear 1	690 V, 1230 A	425 kW, 690 V, 470 A, 743 rpm
Flying shear 2	690 V, 570 A	230 kW, 690 V, 250 A, 741 rpm
Laying forming head (LFH)	690 V, 354 A	258 kW, 690 V, 260 A, 1786 rpm
Pinch roll- Laying forming head (PR-LFH)	690 V, 354 A	258 kW, 690 V, 259 A, 1190 rpm
Cooling bed	690 V, 297 A	180 kW, 690 V, 184 A, 990 rpm



Fig. 9 The laying forming head in the technological production line wire rod rolling mill  $\phi 5$

starting with  $T_{cf} = 50$  ms, overshoot of 6 % in the DC voltage is achieved with  $T_{cf} = 5$  ms (Figure 11). It should be emphasized that this value of the filter time constant is the minimum value. With this value of  $T_{cf}$  there is no interference with the dynamic behaviour of drives connected to the common DC link. Lower values yield more noise in the compensation loop and deteriorate the DC voltage transient response.

The DC link voltage limitation is one of the standard functions in an inverter. During the bra-

king, the inverter limits the speed decrease, while limiting in the same time the DC link voltage at maximum 120 % of the nominal value (Figure 12). This function is used if braking devices (resistors) are not anticipated [7]. This function can also be used as an additional protection of the 4-quadrant SCR converter from too high common DC link voltage. Limiting the common DC link voltage to 120 % of the nominal value, diminishes the danger of having a 4-quadrant SCR converter reaching the critical area of maximum control angle in the inverting regime.

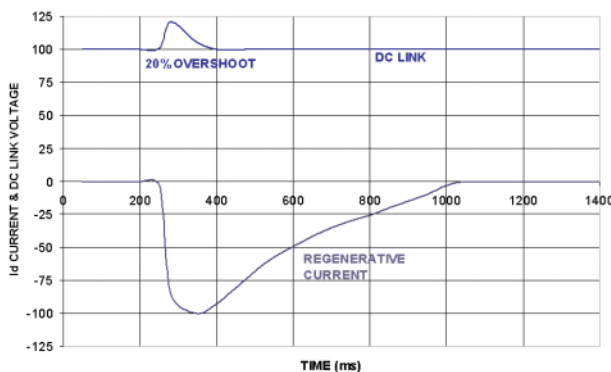

Fig. 10 DC link voltage and current under regenerative braking with LFH drive. Voltage and current in % of rated values.  $K_{pU} = 1$ ,  $T_{iU} = 0,5$  s, experimental result

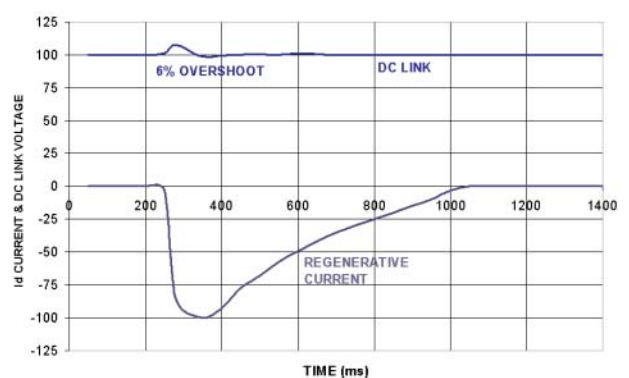

Fig. 11 DC link voltage and current under regenerative braking with LFH drive. Voltage and current in % of rated values.  $K_{pU} = 1$ ,  $T_{iU} = 0,5$  s, compensation filter  $T_{cf} = 5$  ms, experimental result

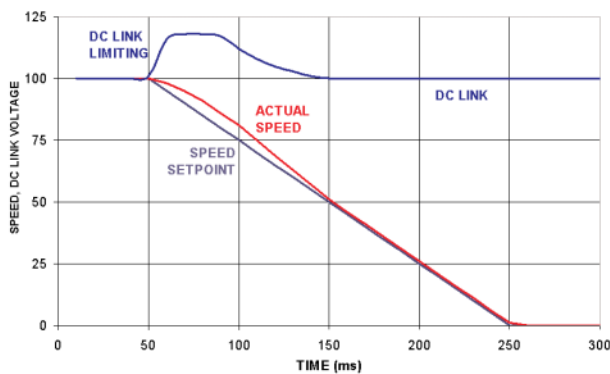

Fig. 12 Slower deceleration as a negative consequence of the DC link voltage limitation in inverter. Voltage and speed in % of rated values, experimental result.

The negative consequence of the common DC link voltage limitation in the inverter is the deterioration of the speed control quality during braking (Figure 12). For the large number of drives this fact is not the problem, but for position controlled drives or tracking control systems, this solution is not acceptable.

The suggested solution with the DC link voltage limitation in an inverter is not necessary and not important in the case of well optimized DC link voltage controller of the 4-quadrant SCR converter. In that case the overshoots of more than 10 % and the DC link voltage limitation workout in the inverter are not expected, as well as negative consequences on the speed response during braking. Because of the security reasons, such a solution can be very practical, thus diminishing the risk of the SCR converter fuses blowing up or even of the SCR converter destruction, particularly during system commissioning and SCR converter controller parameter setup. The proposed solution can serve as the redundancy protection for the SCR converter.

## 6 CONCLUSION

An overview of the supply units for a common DC link of an inverter group for multiple AC adjustable speed drives is presented. The four quadrant SCR bridge converter is described in more detail, particularly its energy and control properties, as well as particularities during regenerative braking regimes. The interaction between the inverter and the 4-quadrant SCR bridge converter during regenerative braking operation is analyzed. It is very important inside the group of drives on a common DC bus to mix regenerative drive with the drives which mostly run in the motoring mode. In

this way the regenerative peaks can be absorbed keeping the DC voltage overshoot below the dangerous limit of 20 %. It is analysed end experimentally verified that the solution with pseudo-derivative feedback (PDF) voltage controller gives better performance considering voltage overshoot than cascade PID controller. With carefully chosen filter time constant in the compensation loop, an optimally tuned DC voltage control system has a considerably smaller voltage overshoot (6 %) during regenerative braking, compared with 20 % voltage overshoot for the system without compensation. The experiments have confirmed that properly tuned compensation, with minimum time filter constant of 5 ms, ensures no interference with dynamic behaviour of the drives connected to the common DC link. The advantages of the applied method particularly during drive commissioning are discussed, as well as possible drawbacks and limitations. The described observations and the results of the analysis are experimentally verified in a wire rod rolling mill  $\phi 5$  with high technological production line speed of 100 m/s.

## REFERENCES

- [1] N. Mohan, T. Undeland, W. Robbins, **Power Electronics: Converters, Applications and Design**. John Wiley & Sons, 1989.
- [2] J. Kassakian, M. Schlecht, G. Verghese, **Principles of Power Electronics**. Massachusetts Institute of Technology, Addison-Wesley, 1991.
- [3] W. Leonhard, **Control of Electrical Drives**. Springer-Verlag, 1996.
- [4] J. Liptak, F. Joyner, J. Guyeska, **Regenerative Controller for a Voltage-Source Inverter Drive**. Textile Industry Technical Conference, Annual Conference, vol. 10, pp. 1–7, Charlotte, NC USA, 3–4. May 1989.
- [5] E. Wiechmann, R. Burgos, J. Rodriguez, **Active Front-End Optimization Using Six-pulse Rectifiers in Multi-motor AC Drives Applications**. IEEE Industry Applications Conference, Thirty-Third IAS Annual Meeting, vol. 2, pp. 1294–1299, St. Louis, MO USA, 1998.
- [6] E. Wiechmann, R. Burgos, D. Boroyevich, **Active Front-End Converter Input Filter Minimization Using Sequential Sampling Space Vector Modulation for Multi-motor Drives**. IEEE Industry Applications Conference, Thirty-Sixth IAS Annual Meeting, vol. 3, pp. 1687–1694, Chicago, IL USA, 2001.
- [7] ..., Siemens, **Operating Instruction Manual – SIMOVERT Regenerative Rectifier Unit**. 1999.
- [8] R. M. Phelan, **Automatic Control Systems**. Cornell University Press, Ithaca, New York, 1977.
- [9] B. C. Kuo, **Automatic Control Systems**, sixth edition. Prentice-Hall International, 1991.
- [10] G. F. Franklin, J. D. Powell, E. Abbas, **Feedback Control Systems**. Addison Wesley, 1994.



**Međudjelovanje pojnog usmjerivača istosmjernog međukruga i napajanih izmjenjivača s izrazito regenerativnim teretom.** U članku je opisano tehničko rješenje grupe izmjeničnih elektromotornih pogona, napajanih iz zajedničkih istosmjernih sabirnica. Osim visokih regulacijskih zahtjeva, opisane pogone karakteriziraju vrlo učestale promjene brzine i momenta, koje zbog rotacijskih masa, zahtijevaju znatnu kočnu snagu. Zahtjevi za postupno nabijanje kondenzatora izmjenjivača, te povrat energije u mrežu tijekom kočenja, u potpunosti opravdavaju primjenu četverokvadrantnog pojnog tiristorskog usmjerivača. Opisane su osnovne značajke sustava, problemi, rješenja i isklustva stečena tijekom puštanja u rad, posebno međudjelovanje pojnog usmjerivača i napajanih izmjenjivača tijekom regenerativnog kočenja. Uz korištenje kompenzacijskog djelovanja po struji istosmjernog međukruga, napravljena je usporedba predloženog pseudo-derivacijskog (PDF) regulatora napona istosmjernog međukruga u odnosu na klasični kaskadni PID regulator. Pokazatelji kvalitete sustava regulacije eksperimentalno su potvrđeni u tehnološkom procesu valjanja žice  $\phi 5$  tijekom regenerativnog kočenja, pri brzini valjanja od 100 m/s.

**Ključne riječi:** tiristorski pojni usmjerivač, istosmjerni međukrug, izmjenjivači, izmjenični pogoni, regenerativno kočenje

#### AUTHORS' ADDRESSES

Assist. prof. Fetah Kolonić, Ph. D.

E-mail: fetah.kolonic@fer.hr

Assoc. prof. Željko Jakopović, Ph. D.

E-mail: zeljko.jakopovic@fer.hr

Faculty of electrical engineering and computing

Department of electrical machines, drives and automation

Unska 3, 10000 Zagreb.

Đino Kunjašić, M. sc.

E-mail: dino.kunjasic@zg.htnet.hr

SIM-AUT d.o.o.

Siječanjska 17, 10000 Zagreb

Received: 2004–10–23