

M. JURKOVIĆ, Z. JURKOVIĆ, M. MAHMIĆ

ISSN 0543-5846

METABK 45 (4) 307-312 (2006)

UDC - UDK 621.983.3:621.774.7:62-462:621.7.016.3:519.863=111

## AN ANALYSIS AND MODELLING OF SPINNING PROCESS WITHOUT WALL-THICKNESS REDUCTION

Received - Primljeno: 2003-12-24

Accepted - Prihvaćeno: 2005-12-25

*Preliminary Note - Prethodno priopćenje*

Through the spinning process it is made the different axial-symmetrical parts by acting spinning roller on blank of sheet metal, which is shaped through a chuck. In the paper is shown an analyse of stressed and strained state, as well as forming force components of spinning process. On the ground of experimental results it is made mathematical modelling of spinning forming force. The obtained mathematical model describes enough accurate and reliable ( $P = 0,98$ ) the spinning forming force.

**Key words:** *modelling, spinning, forming force*

**Analiza i modeliranje procesa rotacijskog tiskanja bez stanjenja debljine stjenke.** Rotacijskim tiskanjem se dobiju različiti osnosimetrični dijelovi djelovanjem pritisknog valjka na pripremak, koji pri deformiranju prijanja uz rotirajući trn. U radu je prikazana analiza napregnutog i deformacionog stanja, kao i komponenata sile procesa rotacijskog tiskanja. Na osnovi eksperimentalnih rezultata izvedeno je matematičko modeliranje deformacijske sile tiskanja. Dobiveni matematički model dovoljno točno i pouzdano ( $P = 0,98$ ) opisuje silu procesa rotacijskog tiskanja.

**Ključne riječi:** *modeliranje, rotacijsko tiskanje, deformacijska sila*

### INTRODUCTION

The modelling of spinning process is similarly to the process of deep drawing. The workpiece is flat blank.

It is obtained by this processing through simple pressing roller the parts of complex form of good mechanical characteristics and surface which quality is near to the quality obtained after grinding.

It can be obtained the different axial-symmetrical parts. The working parts are divided to symmetrical, conical with curved drawing and combined parts. The spinning process doesn't enable to produce of unsymmetrical parts [1 - 7].

Tool design that are used for spinning processing is very simple, that secure smaller price and longer the time of exploitation life. The same tools can be used for individual operations at the different parts producing.

### THEORETICAL BASIS OF SPINNING PROCESS

At the procedure of metal processing through spinning is the main motion circular and it is made by workpiece

(5) together with chuck (1) while auxiliary motion is made by roller (2) (Figure 1.). The beginning material form for processing is usually circular plate (4) pressed by follower in tailstock (3).

The blank, in this case a plain, sheet-metal disc, is concentrically clamped against the follower by the tailstock and driven via the main spindle. Rotating at high speed, the workpiece is then formed by the spinning roller following a pre-set path to produce a series of strokes or passes. Direction of the material flowing speed ( $v_m$ ) during deformation process is the same to the axial speed ( $v$ ) of pressed roller.

### Geometry of spinning procedure

It is obtained by spinning the cylindrical hole parts with bottom as is shown at the Figure 2. The part is made from more operations by the different chucks if it isn't able to get desired cylindrical part from one operation (Figure 2.).

Between chuck and pressed roller ( $\Delta$ ) (Figure 1.) depending on clearance size, the cylindrical parts can be made by reduction and without reduction of wall thickness. The wall thickness and cylinder bottom are the same ( $s_1 = s_0$ ) in the first case and in the second case the wall thickness is smaller than bottom thickness, that is preparing part thickness ( $s_1 < s_0$ ).

M. Jurković, Z. Jurković, Faculty of Engineering University of Rijeka, Croatia, M. Mahmić, Faculty of Technical Engineering University of Bihać, Bosnia and Herzegovina

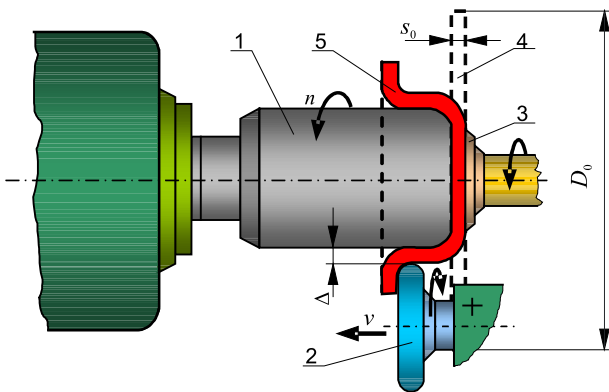

Figure 1. Schema of spinning process  
Slika 1. Shema procesa rotacijskog tiskanja

**Stress - strain state**

The spinning process (Figure 1.), is very similar to deep drawing process to tools at the press. The process is carried out in one pass from circular plain preparing part. For full

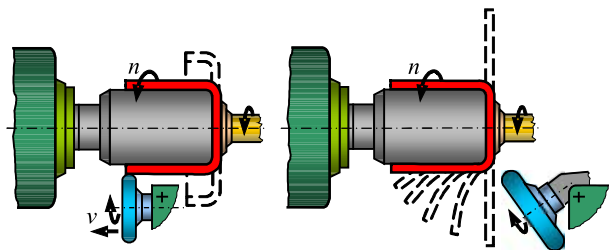

Figure 2. Spinning process  
Slika 2. Proces rotacijskog tiskanja

analysing of strained and stressed state at the spinning it is needed to divide workpiece into several different zones (Figure 3.) at which are occurred different schemes of strain and stress [4, 7].

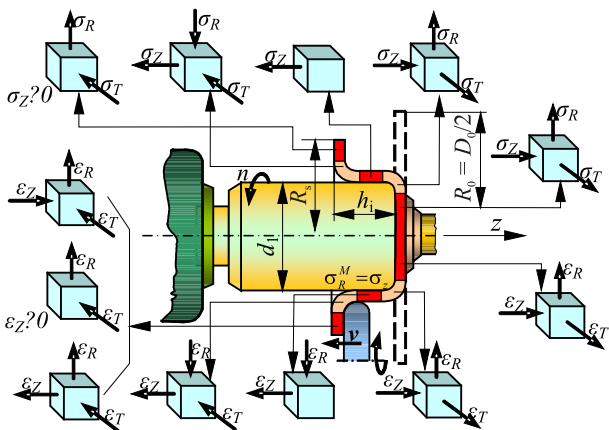

Figure 3. Strain and stresses distribution by spinning process  
Slika 3. Raspodjela deformacija i naprezanja kod procesa rotacijskog tiskanja

The stress state is treated as flat at the element wreath, where it is considered that forming of material is acted by absence of normal stress  $\sigma_z=0$ . This stress state is unlike in according to radial stress ( $\sigma_R$ ) positive and normal stress at the tangent direction is negative ( $\sigma_T$ ).

In the element wreath for an analyse of strain and stress is used the method of common soluting of plasticity conditions in the form:

$$\sigma_R - \sigma_T = \pm \beta k, \tag{1}$$

and balance equation:

$$\rho \frac{d\sigma_R}{d\rho} + \sigma_R - \sigma_T = 0, \tag{2}$$

so that we get differential equation:

$$\rho \frac{d\sigma_R}{d\rho} + \beta k = 0. \tag{3}$$

We get through soluting of differential equation (3) for boundary conditions ( $\rho = R_s, \sigma_R = 0$ ) radial stressed component that incites plastic deformation at the element wreath:

$$\sigma_R = \beta \cdot k_{sr} \ln \frac{R_s}{\rho} \tag{4}$$

where is:

- $k_{sr}$  - the average value of specific flow stress,
- $R_s$  - the immediate value outsideed wreath radius of cylinder (from  $r_1$  to  $R_0$ ),
- $\rho$  - radius inside of intervals  $r_1 \leq \rho \leq R_0$ .

It is getting through involving of express (4) with condition of plastic flow (1) the normal stress at the tangent direction:

$$\sigma_T = \beta \cdot k_{sr} \left( \ln \frac{R_s}{\rho} - 1 \right). \tag{5}$$

At the spinning of cylindrical elements without reducing of wall thickness the maximum axial stress is defined helping expression:

$$\sigma_{z_{max}} = \left( 1, 1k_{sr} \ln \frac{R_s}{r_1} + k_{sr} \frac{s_0}{2\rho_w + s_0} \right) (1 + 1, 6\mu) \tag{6}$$

where:

$$R_s = 0,5 \sqrt{D_0^2 - 4d_{1sr} [h + 0,57(\rho_w + R + s_0)]}.$$

Maximum axial stress ( $\sigma_{Z_{\max}}$ ), obtained by  $h = 0$ .

### Degree of deformation

The fitted relative strain at the element wreath are:

- at the tangent direction:

$$\varepsilon_T = \frac{\rho}{\sqrt{R_0^2 + \rho^2 - R_S^2}} - 1, \quad (7)$$

- at the radial direction (direction of sheet of metal thickness):

$$\varepsilon_R = \frac{1 - 2 \ln \frac{R_S}{\rho}}{2 - \ln \frac{R_S}{\rho}} \cdot \varepsilon_T, \quad (8)$$

- at the axial direction:

$$\varepsilon_Z = -(\varepsilon_T + \varepsilon_R). \quad (9)$$

At the immediate strained zone it is normal strains under pressed roller:

$$\begin{aligned} \varepsilon_T &= \frac{d_1}{a_i} - 1, \\ \varepsilon_R &= \varepsilon_S = \frac{s_1 - s_0}{s_0} \approx 0, \\ \varepsilon_Z &= \varepsilon_h = \frac{2h_i - (a_i - d_1)}{a_i - d_1}. \end{aligned} \quad (10)$$

where:

$a_i = \sqrt{d^2 + 4d_1(h_i + 0,75R)}$  - the immediate value of workpiece diameter which was deformed in the cylinder of  $h_i$  height.

Logarithmic strain at the part under pressed roller are defined by expressions:

$$\varphi_T = \ln \frac{d_1}{a_i}, \quad \varphi_R = \ln \frac{s_1}{s_0} \approx 0, \quad \varphi_Z = \ln \frac{2h_i}{a_i - d_1}. \quad (11)$$

### Forming forces of the spinning process

The axial components of force is determined by expression:

$$F_Z = F_A = \sigma_{Z_{\max}} \cdot A_Z, \quad (12)$$

unless the contact surface of axial force:

$$A_Z = 2ls_0 = 2s_0 \sqrt{d_w \cdot \frac{v}{n}}. \quad (13)$$

On the basis of plastic flowing condition the maximum radial strain expresses:

$$\sigma_{R_{\max}} = \sigma_Z + 1,15k_{sr} \quad (14)$$

and

$$A_R = 2 \frac{v}{n} \sqrt{d_w \cdot \frac{v}{n}} \quad (15)$$

or the maximum component of force is:

$$F_{R_{\max}} = \sigma_{R_{\max}} \cdot A_R. \quad (16)$$

Owing to simplifying the state of deformation it is taken into account the plane state of deformation and the tangent stress is:

$$\sigma_{T_{\max}} = \frac{\sigma_Z + \sigma_R}{2} = \frac{1,15k_{sr}}{2} \quad (17)$$

and tangent components of force:

$$F_{T_{\max}} = \sigma_{T_{\max}} \cdot A_T \quad (18)$$

where the contact surface is:

$$A_T = \frac{1}{2} s_0 \sqrt{2\rho_w \cdot \frac{v}{n}}. \quad (19)$$

The experimental researchings are shown that the maximum radial force occurs immediately at the end of spinning of cylindrical part. The axial stress in this moment equals zero ( $\sigma_Z = 0$ ). Total force:

$$F = \sqrt{F_A^2 + F_R^2 + F_T^2}. \quad (20)$$

## THE EXPERIMENTAL ANALYSIS OF THE PROCESS

The experimental analyse of spinning process is made in the aim of measuring the forming forces which are used for modelling and simulation of the spinning process (Figure 4.).

### The experimental tool for measuring spinning force components

In Figure 5. is given the presentation of force compo-

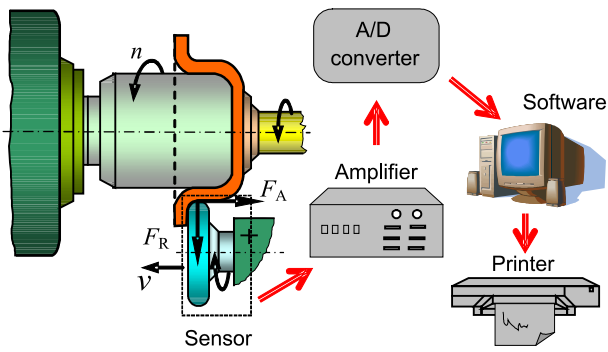

Figure 4. Presentation of measuring system  
Slika 4. Prikaz mjernog sustava

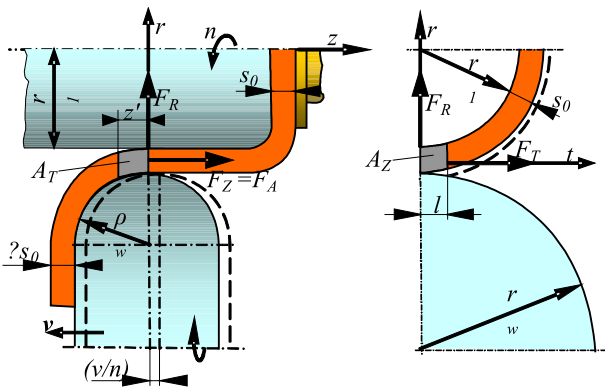

Figure 5. The spinning force components  
Slika 5. Komponente sile procesa rotacijskog tiskanja

nents at the spinning and Figure 6. is shown the experimental tool for measuring spinning force components.

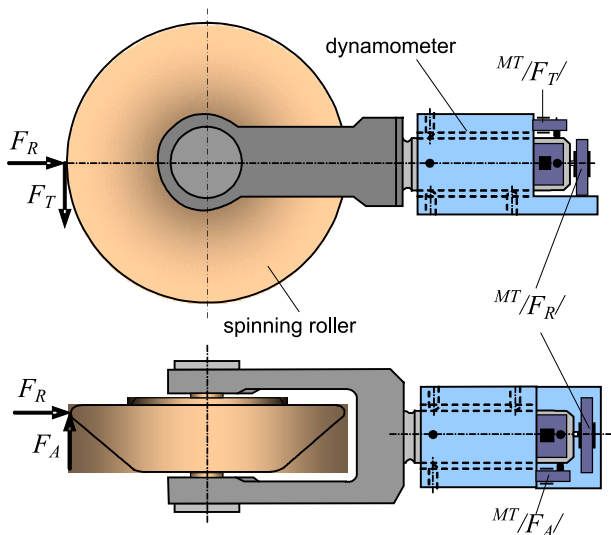

Figure 6. The experimental tool with built-in force sensors [2]  $F_A$ ,  $F_R$  and  $F_T$   
Slika 6. Eksperimentalni alat s ugrađenim senzorima sile [2]  $F_A$ ,  $F_R$  i  $F_T$

**The experimental results**

On the basis of acquired data for material, revolutions numbers of the main spindle, the feed of pressed roller, roller diameter, lubrication means are obtained the values of force components depends on roller motion (Table 1.).

Table 1. The experimental results of spinning forces  
Tablica 1. Eksperimentalni rezultati sile rotacijskog tiskanja

Trial $N_j$	The physical variables of processes			The experimental values of forces			
	$v$ / mm/min	$s$ / mm	$h$ / mm	$F_A$ / N	$F_R$ / N	$F_T$ / N	$F$ / N
1	100	1,0	5	127	129	33	184
2	200	1,0	5	160	157	44	228
3	100	2,0	5	215	222	57	314
4	200	2,0	5	252	255	69	365
5	100	1,0	25	199	358	56	413
6	200	1,0	25	241	441	71	508
7	100	2,0	25	326	580	95	672
8	200	2,0	25	371	673	111	776
9	150	1,5	15	402	233	102	476
10	150	1,5	15	378	220	95	448
11	150	1,5	15	408	218	98	473
12	150	1,5	15	409	228	106	480

In the Figure 7. are given the obtained experimental values for Č0148 (DIN St14) and  $s_0 = 1$  mm.

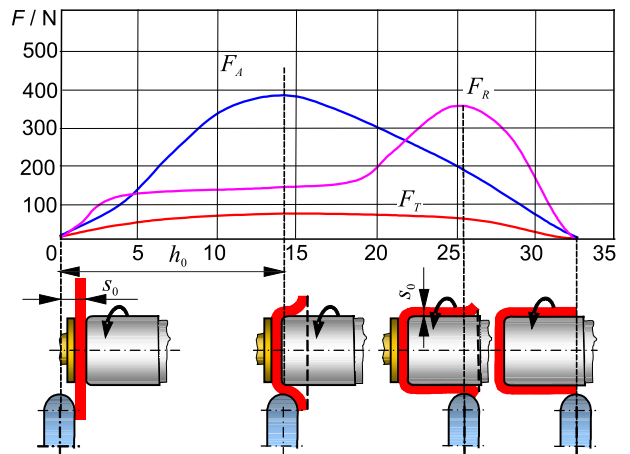

Figure 7. Force components of spinning  
Slika 7. Komponentne sile rotacijskog tiskanja

Analyzing recorded diagrams it can be concluded the following:

- the pressed roller moves during the process by constant speed,
- the tangent component has nearly constant value during the process,
- the maximum value of radial force occurs at the end of the process,
- the decreasing of axial force after reaching of maximum is stepped (at the cylindrical parts obtained through combined action) but at the parts obtained without reducing the decreasing of axial force is extended.

**FORCE MODELLING**

**The parameter choosing of spinning process**

On the basis of the experimental results is made a modelling of spinning force (Table 1.).

The varying parameters are defined over input variables of process which define the experiment conditions varying at the three levels: axial speed of pressed roller,  $v$  / (mm/min), wall thickness of the blank,  $s$  / mm and pressed roller path,  $h$  / mm.

The constant parameters of process are: material of preparing part, radius of cycled tools, diameter and product, etc. [1].

Table 2. The physical and coded values of process parameters  
 Tablica 2. Fizikalne i kodirane vrijednosti parametara procesa

Influencing parameters	The coded and physical values of input parameters			
Coded parameters	$X_i$	-1	0	1
Physical parameters	$X_1 = v$	100	150	200
	$X_2 = s$	1,0	1,5	2,0
	$X_3 = h$	5	15	25

**The defining of mathematical model**

The number of experiment needed for modelling is defined by expression:

$$N = 2^k + n_0 = 2^3 + 4 = 12,$$

where:

$N$  - the total experiment number,

$k$  - number of parameters,

$n_0$  - the replied experiment number at the central point of a plan.

The force function of spinning is modelled by following polynom function at the coded form:

$$Y = F = b_0 + b_1 X_1 + b_2 X_2 + b_3 X_3 + b_{12} X_1 X_2 + b_{23} X_2 X_3 + b_{13} X_1 X_3 + b_{123} X_1 X_2 X_3 \quad (21)$$

The further modelling action understand the determining coefficients of mathematical model to expression:

$$b_0 = \frac{1}{N} \sum_{j=1}^N y_j,$$

$$b_i = \frac{1}{N - n_0} \sum_{j=1}^N X_{ij} y_j, \text{ za } i = 1, 2, \dots, k,$$

$$b_{im} = \frac{1}{N - n_0} \sum_{j=1}^N X_{ij} X_{mj} y_j, \text{ za } 1 \leq i < m < k. \quad (22)$$

where:

$b_0, b_i, b_{im}$  - coefficients of mathematical model,  
 $X_{ij}, X_{mj}$  - coded values.

The values of the coefficient of mathematical models are:

$$b_0 = 442; b_1 = 37; b_2 = 99; b_3 = 160;$$

$$b_{12} = 2,078; b_{23} = 32,58; b_{13} = 13; b_{123} = 0,481.$$

Taking in attention only significant coefficients of regression, the mathematical model of force has the form:

$$Y = F = 442 + 37 X_1 + 99 X_2 + 160 X_3 + 32,58 X_2 X_3 \quad (23)$$

Table 3. The experimental and calculated force values (23)  
 Tablica 3. Eksperimentalne i izračunate vrijednosti sile (23)

Trial $N_j$	Coded variables of proces			The numerical results of the spinning force / N	
	$X_1$	$X_2$	$X_3$	The experimental values $Y_j = F_j$	Calculated values
1	-1	-1	-1	184	179
2	1	-1	-1	228	253
3	-1	1	-1	314	311
4	1	1	-1	365	385
5	-1	-1	1	413	433
6	1	-1	1	508	507
7	-1	1	1	672	697
8	1	1	1	776	771
9	0	0	0	476	442
10	0	0	0	448	442
11	0	0	0	473	442
12	0	0	0	480	442

The coefficient of multiple regression  $R = 0,993$  shows very good correlation between varying  $X_i$  and spinning force  $F_j$ .

The mathematical model (23) enough correctly and reliable ( $P = 0,98$ ) describes the process force of spinning inside the space of applied experiment what shows the comparing of experimental and calculated values (Table 3.).

Encoding the mathematical model (23) is obtained the physical mathematical model of the spinning force in the form of:

$$Y = -59,39 + 0,74v + 100,26s + 6,226h + 6,516s \cdot h \quad (24)$$

## CONCLUSIONS

In according to deep drawing this procedure has defined advantages:

- enable producing of complex products,
- deformation is made in the part under pressed roller, unless at deep drawing at the whole volume of part countour,
- the tools are more simple design than the tools of deep drawing,
- the tool life is longer and tool costs are smaller,
- smaller forming force,
- the tool is flexible because the same can be used for different parts producing.

The ground failures are:

- unsymmetrical parts can't be produce,
- smaller production in according to deep drawing.

The mathematical modelling of the force of spinning enough correctly and reliable describes forming force, that are confirmed by obtained model of the that has reliability  $P = 0,98$  and the coefficient of multiple regression  $R = 0,993$ .

## REFERENCES

- [1] M. Jurković, Mathematical Modelling and Optimization of Machining Processes, Faculty of Engineering, University of Rijeka, Rijeka, 1999, p. 151 - 176 and 335 - 386.
- [2] D. Lazarević, Sile pri rotacionom izvlačenju koničnih delova, XVIII Savetovanje proizvodnog mašinstva Jugoslavije, Mašinski fakultet, Niš, 1984, p. 363 - 377.
- [3] M. Jurković, Band Cross Section Geometry in the Function of Thermo-Mechanical Factors and Stress State of Cold Forming Processes, Dissertation thesis, 1981, p. 148 - 192.
- [4] D. Lazarević, V. Stoiljković, Naponsko - deformaciono stanje i sile pri rotacionom izvlačenju cilindričnih delova bez redukcije debljine zida, XVII Savetovanje proizvodnog mašinstva Jugoslavije, Titograd, 1983, p. III19 - III22.
- [5] K. Lange, Lehrbuch der Umformtechnik, Band 3, Blechbearbeitung, Springer-Verlag, Berlin-Heidelberg New York, 1975, p. 1 - 456.
- [6] M. Jurković, Z. Jurković, Direct Determining of Stress and Friction Coefficient on the Contact Surface of Tool and Workpiece, Proc. 1<sup>st</sup> Int. Conf. ICIT '97, 1 (1997), Ljubljana - Maribor, p. 127 - 132.
- [7] N. I. Mogiljnj, Rotacionaja vytyžka oboločkovykh detalej na stankah, Mašinstroenie, Moskva, 1983, p. 1 - 190.

## List of symbols

$n$	- revolutions numbers of chuck /min <sup>-1</sup>
$v$	- axial speed of pressed roller /(mm/min)
$v_m$	- the material flowing speed /(mm/min)
$D_0$	- diameter of workpiece (blank diameter) /mm
$d_1$	- diameter of rotary chuck (chuck diameter) /mm
$r_1$	- chuck radius /mm
$d$	- diameter of finished product /mm
$s$	- wall thickness /mm
$s_0$	- initial sheet thickness /mm
$d_w$	- diameter of pressed roller /mm
$\rho_w$	- roller radius /mm
$h$	- pressed roller path /mm
$l$	- spinning length /mm
$d_{1sr}$	- the immediate diameter of workpiece wreath /mm
$R_0$	- blank radius /mm
$R_s$	- the immediate value outsideed wreath radius of cylinder (from $r_1$ to $R_0$ ) /mm
$a_i$	- the immediate value of workpiece diameter which was deformed in the cylinder of $h_i$ height /mm
$v/n$	- spinning feed of roller /mm·rev <sup>-1</sup>
$k$	- number of parameters
$k_{sr}$	- the average value of flow stress /Pa
$\Delta s$	- absolute reducing of wall thickness /mm
$\alpha_0$	- angle of chuck /°
$\alpha$	- angle of pressed roller /°
$\beta$	- Lode coefficient ( $\beta = 1,0$ to $1,55$ )
$\mu$	- coefficient of friction
$\rho$	- radius inside of intervals $r_1 \leq \rho \leq R_0$ /mm
$\sigma_R, \sigma_Z, \sigma_T$	- radial, axial and tangent stress /Pa
$\sigma_{R_{max}}, \sigma_{Z_{max}}, \sigma_{T_{max}}$	- maximum stresses in radial, axial and tangent direction /Pa
$\varepsilon_R, \varepsilon_Z, \varepsilon_T$	- the relative strains in radial, axial and tangent direction
$\varphi_R, \varphi_Z, \varphi_T$	- logarithmic strains
$F_R, F_Z, F_T$	- the force components in radial, axial and tangent direction /N
$F_{R_{max}}, F_{Z_{max}}, F_{T_{max}}$	- maximum force in radial, axial and tangent direction /N
$F$	- total force /N
$A_R, A_Z, A_T$	- the pressed contact surface at the radial, axial and tangent direction /mm <sup>2</sup>
$X_{ij}, X_{mj}$	- coded values
$n_0$	- the replied experiment number at the central point of a plane
$b_0, b_f, b_{im}$	- coefficients of mathematical model
$N$	- the total experiment number
MT	- strain gages