

QUANTIFICATION OF RESIDUAL STRESSES IN HOT ROLLED STEEL SHEETS BY THE HOLE DRILLING METHOD

Received - Primljeno: 2005-04-21

Accepted - Prihvaćeno: 2006-03-10

Preliminary Note - Prethodno priopćenje

The paper deals with the problems of quantification of residual stresses in hot rolled sheets produced under various regimes. On the base of stress distribution along width and thickness of the belt is pointed out on possibilities of belt deformation from the plane as a result of action of torsional moment as an integral internal quantity in cross-section. For the non-uniformly distributed stresses along the thickness of the sheet the new method for residual stresses determination was developed. Application of the method is described in the paper.

Key words: *hot rolled steel sheets, residual stresses, drilling method*

Utvrdba zaostalih napreznja u čeličnim toplo valjanim trakama metodom bušenja. Članak se zaokuplja problemima utvrdbe zaostalih napreznja u čeličnim toplo valjanim trakama izrađenih pri raznim režimima. Na temelju rasporeda napreznja po debljini trake se ukazuje na mogućnost deformacije trake po ravnini, kao rezultat djelovanja torzionog momenta kao ukupna unutarnja veličina po presjeku. Pri neravnomjernom rasporedu napreznja po debljini trake bila je predložena nova metoda. Primjena ove metode opisana je u članku.

Ključne riječi: *toplo valjane čelične trake, zaostala napreznja, metoda bušenja*

INTRODUCTION

The residual stresses in sheets are the stresses that exist in object in the absence of external loading. These stresses are generated by technological process or by previous loading. In principle all technological processes - rolling, forming, thermal processing and so on - generate in produced object residual stresses [1 - 5].

The measurement of residual stresses can not be provided by conventional procedures of experimental stress analysis, because the strain indicator (electrical-resistance strain gage, photoelastic coating) is absolutely insensitive to load history of examined part and it measures only strain changes after its installation. For determination of residual stresses by standard indicators, the stresses remaining within a structure have to be somehow released (with applied indicator) so that the gages register the strain change induced by stress removing. In past, this was accomplished by destruction of examined part by cutting of material levels on the surface or by trepanation. Strain gages applied before cutting on the structure give response

proportional to strains that are invoked by releasing of residual stresses.

The residual stresses computation work on the presumption that they are elastic. Many of these techniques are dedicated for laboratory applications on plane or cylindrical specimens and it is not easy to adopt them to real objects of arbitrary sizes and shapes. In current state of development the hole drilling strain gage method is preferentially used for uniform or almost uniform residual stress distribution along the depth of material. The procedures of getting data and their interpretation for such cases are well-elaborated and simple, but in special situations the treatments for verification of stress uniformity and other parameters are needed. The laboratory of authors has hardware and software for the measurement of residual stresses varying through the thickness.

The paper describes the results gained during measurement of residual stresses in hot rolled sheets. The sheets are produced in the form of scrolls or plates. They are further divided by customers into bands, and during this process (as a consequence of residual stresses relaxation) undesirable deformations of divided pars can occur. This phenomenon is inadmissible during processing of band on high-speed production lines and so the aim of the sheet producers is to reduce the level of residual stresses to the lowest possible size.

F. Trebuňa, F. Šimčák, J. Bocko, P. Šarga, M. Pástor, P. Trebuňa, Faculty of Mechanical Engineering Technical University of Košice, Košice, Slovakia, M. Buršák, Faculty of Metallurgy Technical University of Košice, Košice, Slovakia

BASIC DATA ABOUT CHEMICAL COMPOSITION AND MATERIAL PROPERTIES OF THE INVESTIGATED SHEETS

The residual stresses in hot rolled sheets produced in two different thermo-mechanical regimes with the same steel quality were determined by the hole drilling strain gage method. The first rolling technology was named as “original” the second one as “alternative”. Chemical composition of steel sheets is given in Table 1.

Table 1. Chemical composition of investigated steel sheets, in weight / %
 Tablica 1. Kemijski sastav istraživanih čeličnih traka, težinski / %

Element	C	Mn	Si	P	S
Amount	0,1729	1,45	0,009	0,014	0,0051
Element	Al	Mo	Ti	V	Nb
Amount	0,035	0,002	0,001	0,002	0,029
Element	Zr	B	Ca	Cu	Ni
Amount	0,001	0,0002	0,0002	0,022	0,017
Element	As	Sn	Sb	Cr	N ₂
Amount	0,007	0,006	0,002	0,017	0,0053

In Figure 1. are shown the histograms of mechanical properties of sheets produced by original and alternative technology. Because the values of Young modulus *E* and

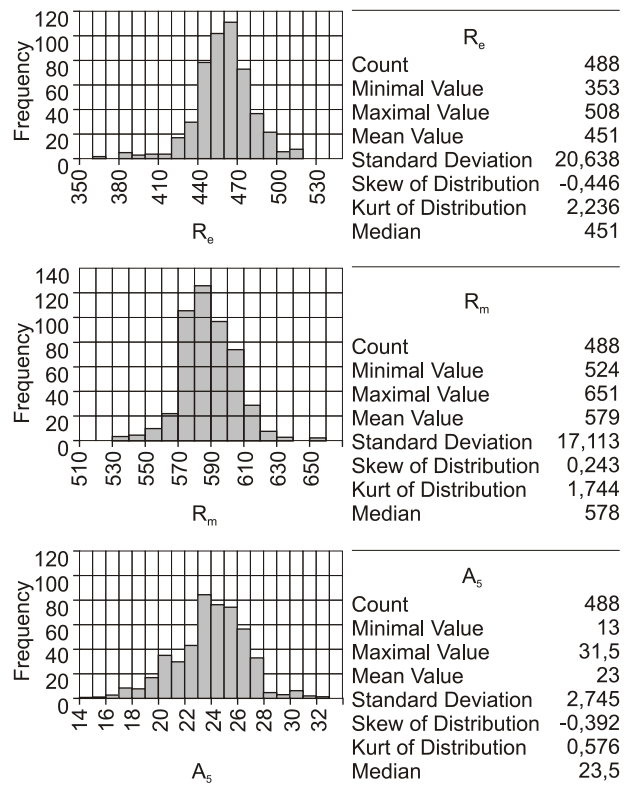

Figure 1. Histograms of mechanical properties of sheets produced by original and alternative technology
 Slika 1. Histogram mehaničkih vrijednosti traka izrađenih izvornom i alternativnom tehnologijom

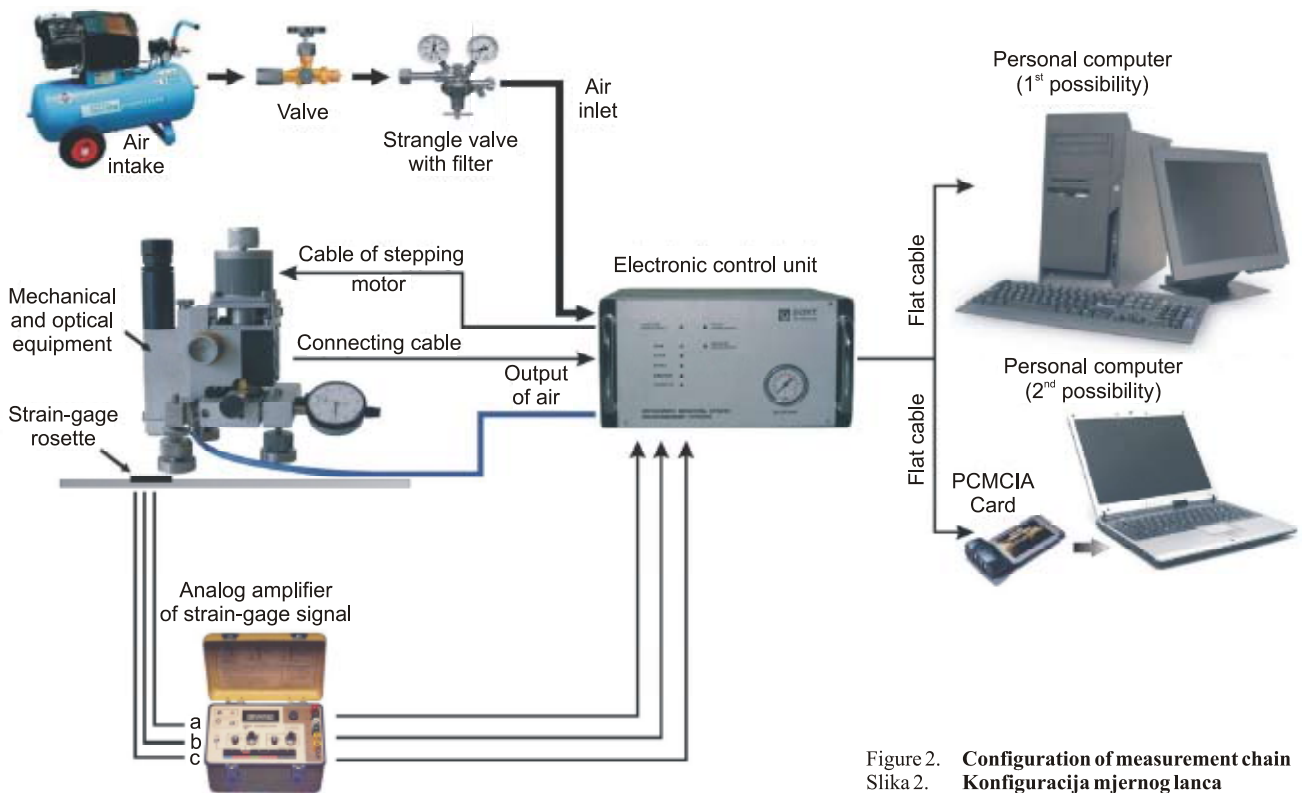

Figure 2. Configuration of measurement chain
 Slika 2. Konfiguracija mjernog lanca

Poisson ratio μ were not quoted by producer of sheets, there were according to [9], [6] used the values $E = 2,05 \times 10^5$ MPa, $\mu = 0,3$.

METHODOLOGY FOR MEASUREMENT OF RESIDUAL STRESSES

Measurement and control chain consists of system for measurement of residual stresses SINT MTS 3000, strain gage measurement device, source of compressed air, and reduction valve with filter and computer with program system RESTAN.

Schema of the measurement chain is given in Figure 2. As mentioned above, the measurements of directions and levels of residual stresses were provided on materials produced by two different technologies and they were carried out on specimens made from scrolls or plates. In order to have a possibility to differentiate and quantify the residual stress levels and directions, the drilling was provided as a

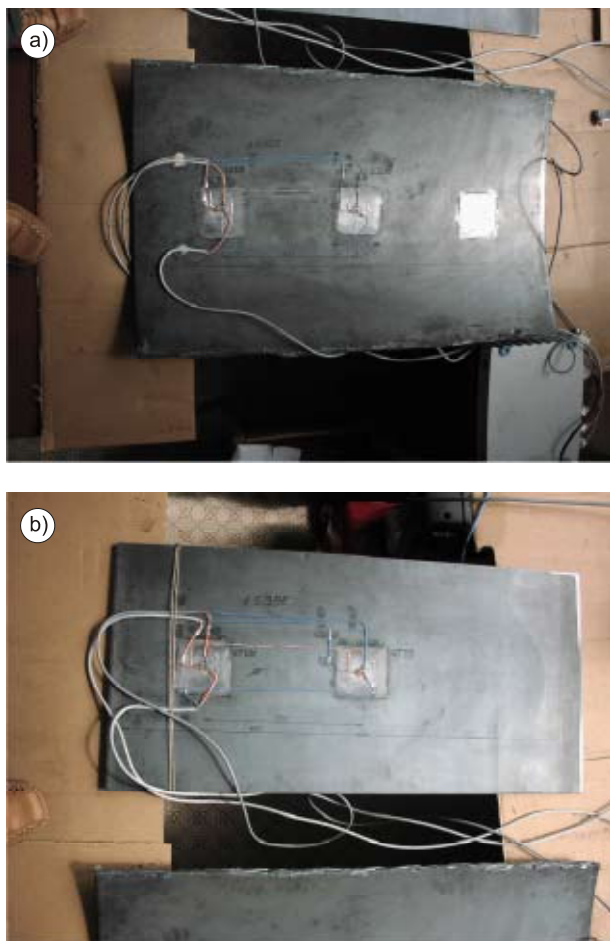

Figure 3. Specimens taken from the sheet produced by original technology of rolling a) specimen taken from scroll, b) specimen taken from plate
Slika 3. Uzorci uzeti s trake izrađeni izvornom tehnologijom valjanja: a) iz koluta, b) iz pločevine

rule for particular location on both sides of the specimen. Bonded strain gages for both technology types are shown in Figure 3. and Figure 4.

In Figure 3. are given specimens produced by original technology of rolling taken from the scroll (Figure 3.a) and (Figure 3.b) plate sheet.

In Figure 4. are given specimens produced by alternative technology of rolling taken from the scroll (Figure 4. a) and (Figure 4.b) plate sheet. For the measurement were used strain gages 1RY61 S-1.5/120 with electrical resistance $120 \Omega \pm 1 \%$, gage factor $1,94 \pm 1,5 \%$ and thermal expansion coefficient $\alpha = 10,8 \times 10^{-6} \text{ } ^\circ\text{C}^{-1}$.

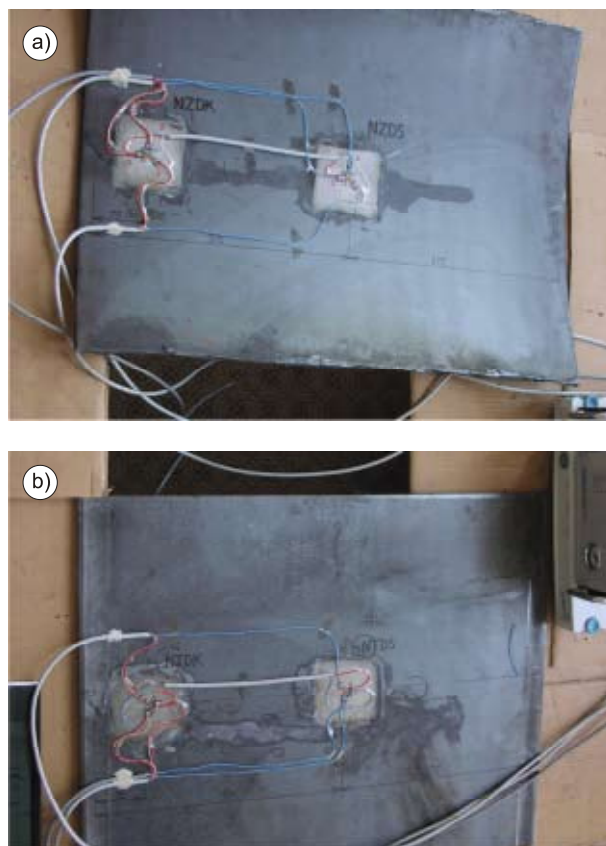

Figure 4. Specimens taken from the sheet produced by alternative technology of rolling a) specimen taken from scroll, b) specimen taken from plate
Slika 4. Uzorci uzeti s trake izrađeni alternativnom tehnologijom valjanja: a) iz koluta, b) iz pločevine

The residual stresses computed from measured residual strains in scrolls and plates were determined on both sides of specimens and two locations along their widths. During the measurement was discovered a fact that released strains in correlation with ratio of depth of drilled hole to average diameter of gage rosette do not lie in normalized area. In accordance with ASTM E 837-01 (besides evaluation according to ASTM) further three methods for determination of stresses with non-uniform stress distribution along

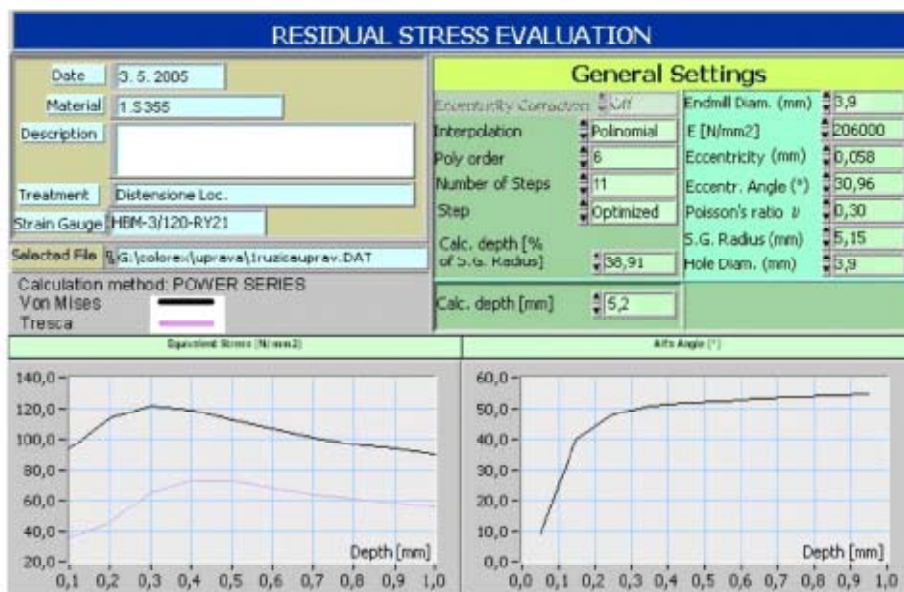

Figure 5. Residual stresses determined by the Method of Power Series
Slika 5. Zaostala napreznaja određena metodom Power Series

drilled hole were used. In addition, there were provided steps allowing interpolation of measured data.

Besides of evaluation according to ASTM E 837-01 were used:

- Integral Method,
- Kockelmann Method,
- Method of Power Series.

Identification of locations for measurement was following: the first symbol in labeling determines material or

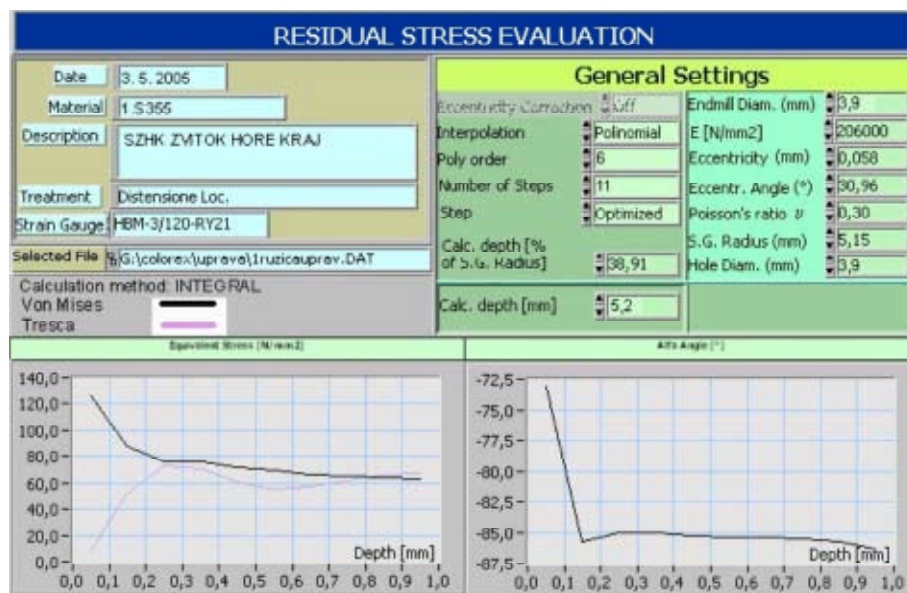

Figure 6. Residual stresses determined by the Integral Method
Slika 6. Zaostala napreznaja određena Integralnom metodom

production technology of sheet rolling (original or alternative). Rolled sheet produced by alternative technology was chilled by different way. The first letter (S) determines material produced by original (old) technology of rolling. The letter (N) determines material produced by alternative (new) rolling technology. The second letter (Z) indicates scroll and the letter (T) determines plate. The third letter (H) indicates upper side of sheet during its movement through rolling mill while with the letter (D) is marked its underneath side.

The fourth letter determines the location of strain gage on specimen, where (S) indicates the middle part of band and (K) its boundary.

RESULTS

Residual stresses were determined in 16 locations of investigated sheets. The results of individual methods (ASTM, Integral Method, Kockelmann Method, Method of Power Series) were put together in tables and graphs in the form of output from the system SINT MTS 3000 - system for the measurement of residual stresses. A detailed description of windows in system SINT MTS 3000 is given in [8]. In Figures 4. and 5. are given examples of outputs gained from the measurements. Summary of all results is contained in [7].

Results of measurements unambiguously showed that stresses are distributed non-uniformly along depth of the hole and accordingly there are not fulfilled the conditions given in ASTM standards. Because the Code ASTM E 837-01 is the only one that gives standard for evaluation of residual stresses we provide readers also with results evaluated according this Code. In Figures 7., 8., 9., 10. are given magnitudes and directions of principal residual stresses on upper and underneath sides of specimens taken from scrolls

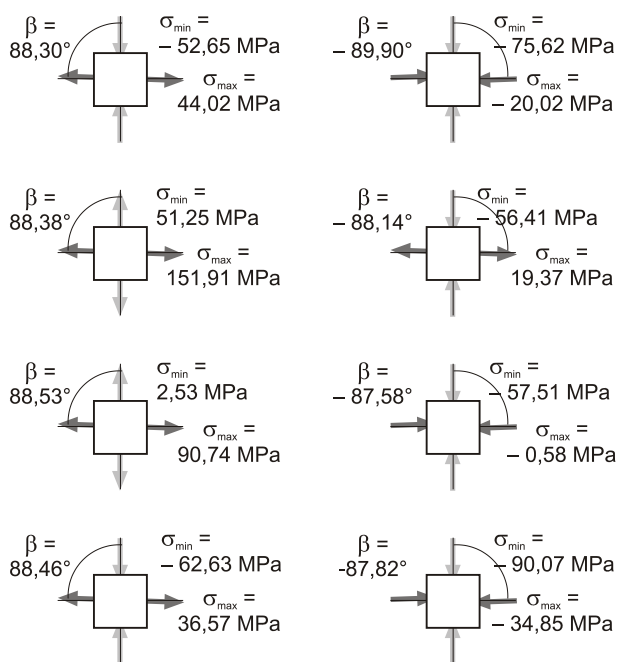

Figure 7. Magnitudes and directions of principal residual stresses on specimen taken from scroll, upper side, and original technology of rolling

Slika 7. Veličina i smjer glavnih zaostalih naprezanja uzorka uzetog iz koluta, gornja strana, izvorna tehnologija valjanja

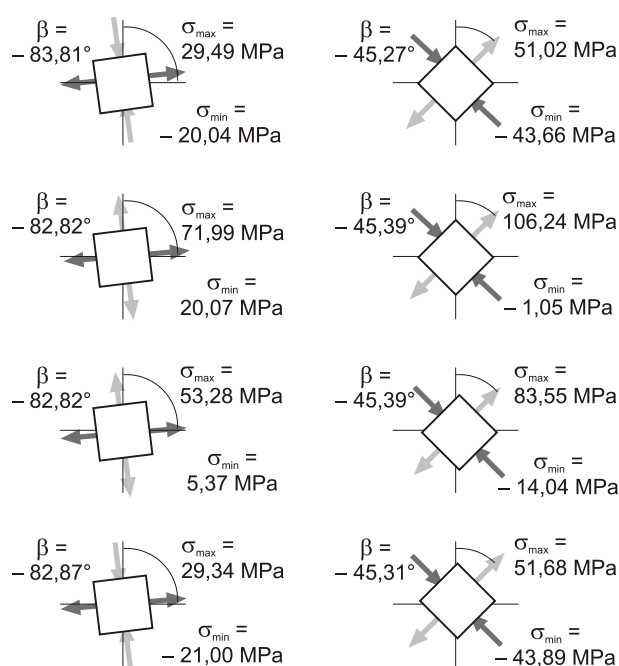

Figure 9. Magnitudes and directions of principal residual stresses on specimen taken from scroll, upper side, alternative technology of rolling

Slika 9. Veličina i smjer glavnih zaostalih naprezanja uzorka uzetog iz koluta, gornja strana, alternativna tehnologija valjanja

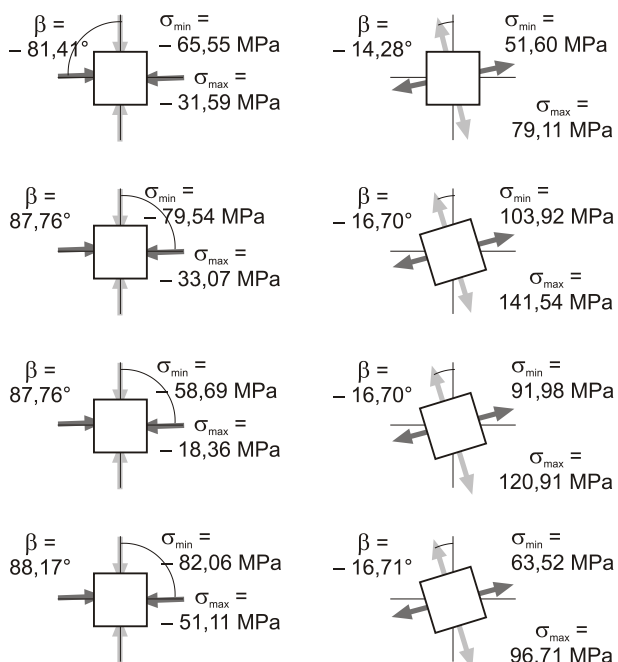

Figure 8. Magnitudes and directions of principal residual stresses on specimen taken from scroll, underneath side, original technology of rolling

Slika 8. Veličina i smjer glavnih zaostalih naprezanja uzorka uzetog iz koluta, donja strana, izvorna tehnologija valjanja

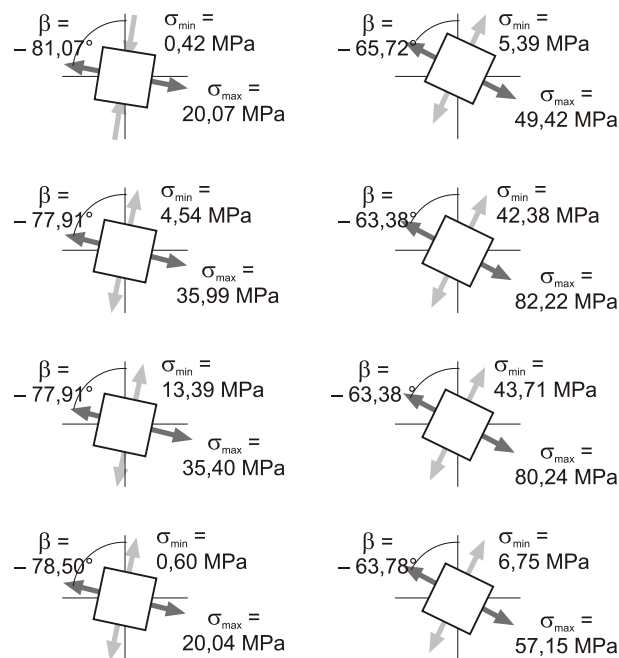

Figure 10. Magnitudes and directions of principal residual stresses on specimen taken from scroll, underneath side, alternative technology of rolling

Slika 10. Veličina i smjer glavnih zaostalih naprezanja uzorka uzetog iz koluta, donja strana, alternativna tehnologija valjanja

produced by old (original) and new (alternative) technology. The manner of labeling of measured locations is in accordance with description given in section “Methodol-

3. The scrolls produced by alternative technology of rolling have on their boundaries residual stresses that can result to the curling of the sheets.

4. The values of residual stresses in specimens taken from the plate produced by alternative technology are generally significantly smaller than they are in specimens from the plate produced by original technology.

5. Higher values of residual stresses in cross-section were determined in the middle part of plate produced by first technology. The plates made by new technology have significantly smaller stresses in the middle part, but the values of one principal stress are somewhat higher on the boundary.

6. Computed values of residual stresses signalize the need of cooling regime optimization in order to decrease the values of residual stresses through whole cross-section of the sheet.

Table 2. Magnitudes and directions of principal residual stresses in plates
 Tablica 2. Veličina i smjer glavnih zaostalih naprežanja u pločevini

Method	Quantity	Original technology				Alternative technology			
		Upper side		Underneath side		Upper side		Underneath side	
		middle	boundary	middle	boundary	middle	boundary	middle	boundary
ASTM	σ_{max} / Mpa	147,04	80,96	- 105,92	- 31,72	- 11,07	39,85	- 30,52	- 52,18
	σ_{min} / Mpa	112,52	- 12,09	- 155,57	- 167,80	- 38,36	13,43	- 86,08	- 85,83
	β / °	- 67,47	- 0,37	- 83,13	87,15	- 83,04	- 15,51	- 2,73	89,65
Integral	σ_{max} / Mpa	142,05	80,77	230,87	64,83	- 6,29	68,79	- 16,74	22,03
	σ_{min} / Mpa	81,35	15,76	151,43	- 99,45	- 39,19	27,49	- 85,15	- 64,55
	β / °	- 77,02	- 0,09	- 82,91	86,87	89,30	- 15,97	- 8,79	- 83,42
Kockel-mann	σ_{max} / Mpa	132,34	64,59	44,65	20,81	3,20	56,69	- 22,30	- 13,49
	σ_{min} / Mpa	81,18	1,07	- 17,04	- 103,76	- 23,25	34,01	- 74,20	- 79,38
	β / °	- 78,40	0,04	- 83,20	86,82	89,30	- 15,97	- 8,79	- 83,42
Power Series	σ_{max} / Mpa	180,27	90,31	- 149,12	- 62,41	- 20,63	44,25	- 40,12	- 74,40
	σ_{min} / Mpa	135,76	- 11,54	- 204,88	- 202,84	- 51,69	14,23	- 107,50	- 107,34
	β / °	- 77,80	- 0,04	- 82,59	86,91	89,22	- 16,69	- 8,13	- 84,54

ogy for measurement of residual stresses”. In the first line in the figure are given the values according to ASTM, in the second line according to Integral Method, in the third one according to Kockelmann Method and the last line represents the results gained by the Method of Power Series.

Magnitudes and directions of principal residual stresses on upper and underneath side of plates produced by original and new technologies are summarized in Table 2. Labeling is in accordance with Figure 7. to Figure 10.

CONCLUSION

On the base of computed principal residual stresses, their directions as well as magnitudes of equivalent stresses from measured released strains can be stated the following results:

1. The magnitudes of residual stresses in sheets (also in the case of their non-uniformity along the hole depth) produced by different technologies can be unambiguously evaluated on the base of values computed according to ASTM E 837-01.
2. The values of residual stresses in specimens taken from the scrolls and determined according to ASTM E 837-01 (but also by other methods that take into account non-uniform distribution of residual stresses along the hole depth) are smaller for alternative technology of rolling than for the original one.

REFERENCES

- [1] ASTM E 837-01. Standard Test Method for Determining Residual Stresses by the Hole-Drilling Strain-Gage Method.
- [2] S. Holý, a kol.: Experimentální stanovení zbytkových napětí jako podklad pro posouzení vhodného způsobu obrábění. EAN 2005, Brno, 2005.
- [3] S. Holý, V. Hampl, J. Václavík, O. Weinberg: Stanovení zbytkové napjatosti - jeden z nástrojů pro výběr optimální technologie. EAN 2006, Červený Kláštor, 2006, p. 169.
- [4] P. Macura, Z. Bembenek, B. Molinek: Analýza zbytkových napětí bandážovaných válců. EAN 2006, Červený Kláštor, 2006, p. 321.
- [5] P. Macura, A. Fiala: Experimentální analýza zbytkových napětí na nosníku stejné pevnosti. EAN 2004, Plzeň, 2004.
- [6] STN 73 1401. Navrhovanie oceľových konštrukcií, 1998.
- [7] F. Trebuňa, a kol.: Smery a veľkosti zvyškových napätí konštrukčných za tepla valcovaných plechov. Záverečná správa. Košice, September 2005.
- [8] F. Trebuňa, F. Šimčák: Kvantifikácia zvyškových napätí tenzometrickými metódami. Grafotlač, Prešov, 2005, ISBN 80-8073-227-2.
- [9] F. Trebuňa, F. Šimčák: Odolnosť prvkov mechanických sústav. Emilena, Košice, 2005, ISBN 80-8073-148-9.

Acknowledgement

The project was supported by Scientific Grant Agency of Department for Education of Slovak Republic under project No. 1/2187/05 and No. 1/1073/04.